

(19)



(11)

EP 2 967 228 B1

(12)

EUROPEAN PATENT SPECIFICATION

(45) Date of publication and mention of the grant of the patent:
07.03.2018 Bulletin 2018/10

(51) Int Cl.:
A47C 27/08 ^(2006.01) **A47C 31/12** ^(2006.01)
A61B 5/11 ^(2006.01) **A61B 5/00** ^(2006.01)
A47C 31/00 ^(2006.01) **A61B 5/08** ^(2006.01)

(21) Application number: **14720361.6**

(86) International application number:
PCT/US2014/026568

(22) Date of filing: **13.03.2014**

(87) International publication number:
WO 2014/151854 (25.09.2014 Gazette 2014/39)

(54) INFLATABLE AIR MATTRESS AUTOFILL AND OFF BED PRESSURE ADJUSTMENT

AUTOMATISCHE FÜLLUNG UND DRUCKEINSTELLUNG EINER AUFBLASBAREN LUFTMATRATZE

RÉGLAGE DE PRESSION D'AUTO-REMPLEISSAGE ET HORS DE LIT DE MATELAS PNEUMATIQUE GONFLABLE

(84) Designated Contracting States:
AL AT BE BG CH CY CZ DE DK EE ES FI FR GB GR HR HU IE IS IT LI LT LU LV MC MK MT NL NO PL PT RO RS SE SI SK SM TR

- **PALASHEWSKI, Wade Daniel**
Minneapolis, MN 55442 (US)
- **YOUNG, Steven**
San Jose, California 95113 (US)
- **HEWITT, Carl**
San Jose, CA 95113 (US)

(30) Priority: **14.03.2013 US 201361781541 P**

(43) Date of publication of application:
20.01.2016 Bulletin 2016/03

(74) Representative: **Conroy, John**
Fish & Richardson P.C.
Highlight Business Towers
Mies-van-der-Rohe-Straße 8
80807 München (DE)

(73) Proprietors:

- **SELECT COMFORT CORPORATION**
Minneapolis, Minnesota 55442 (US)
- **SleepIQ Labs Inc.**
San Jose CA 95113 (US)

(56) References cited:
EP-A2- 1 884 224 US-A- 5 948 303
US-A1- 2012 090 698

(72) Inventors:

- **NUNN, Rob**
Eden Prairie, Minnesota 55346 (US)

EP 2 967 228 B1

Note: Within nine months of the publication of the mention of the grant of the European patent in the European Patent Bulletin, any person may give notice to the European Patent Office of opposition to that patent, in accordance with the Implementing Regulations. Notice of opposition shall not be deemed to have been filed until the opposition fee has been paid. (Art. 99(1) European Patent Convention).

Description

DETECTION TECHNIQUES."

TECHNICAL FIELD

[0001] This patent document pertains generally to air mattresses.

BACKGROUND

[0002] In various examples, an air mattress control system allows a user to adjust the firmness or position of an air mattress bed. The mattress may have more than one zone thereby allowing a left and right side of the mattress to be adjusted to different firmness levels. Additionally, the bed may be adjustable to different positions. For example, the head section of the bed may be raised up while the foot section of the bed stays in place. In various examples, two separate remote controls are used to adjust the position and firmness, respectively. US 2012/090698 A1 discloses a pressure control and feedback system for an adjustable foam support includes a vacuum pump for drawing air from a hermetically sealed foam core to reduce the firmness of the core. A valve opens to permit and closes to block the passage of air into and out of the core. A remotely operated controller generates control signals to selectively start and stop operation of the pump, and selectively open and close the valve, which provides a selected level of pneumatic pressure and corresponding firmness in the core. A pressure sensor detects the pressure and firmness of the core and generates representative feedback signals. An indicator device responsive to the feedback signals indicates the sensed firmness of the core. Software calibrates the system and provides the system with intelligent operation. US 5 948 303 A discloses a temperature control apparatus for a bed includes at least one heating element, mounted in a resting surface on a mattress of the bed for warming at least a first area of the resting area. A temperature sensor is located to detect the temperature of the first area of the resting area, and transmits the information to a central control unit. The central control unit includes a central processing unit which is interconnected with both the heating element and the temperature sensor to adjust the temperature in the first, area of the resting area as desired. The central control unit is also connected to a timer to permit programming of temperature changes as desired. An occupant sensor in the resting surface of the mattress will detect the presence and absence of an occupant, and transmit this information to the central control unit for processing. EP 1 884 224 A2 discloses a patient support having an air permeable layer, a plurality of inflatable bladders, a pressure sensing assembly, and a controller. In one embodiment, a combination of transverse bladders and vertically oriented can-shaped bladders is provided. In one embodiment, one or more angle sensors are provided in

articulatable sections of the patient support

BRIEF DESCRIPTION OF DRAWINGS

5 **[0003]** Some embodiments are illustrated by way of example and not limitation in the figures of the accompanying drawings in which:

10 FIG. 1 is a diagrammatic representation of an air bed system, according to an example.

FIG. 2 is a block diagram of various components of the air bed system of FIG. 1, according to an example.

15 FIG. 3 is a block diagram of an air bed system architecture, according to an example

FIGS. 4-5 are flowcharts of methods to adjust the pressure of an air mattress, according to various examples.

20 FIG. 6 is a block diagram of machine in the example form of a computer system within which a set instructions, for causing the machine to perform any one or more of the methodologies discussed herein, may be executed.

25 DETAILED DESCRIPTION

[0004] The present invention is defined in the claims.

30 **[0005]** FIG. 1 is a diagrammatic representation of air bed system 10 in an example embodiment. System 10 can include bed 12, which can comprise at least one air chamber 14 surrounded by a resilient border 16 and encapsulated by bed ticking 18. The resilient border 16 can comprise any suitable material, such as foam.

35 **[0006]** As illustrated in FIG. 1, bed 12 can be a two chamber design having a first air chamber 14A and a second air chamber 14B. First and second air chambers 14A and 14B can be in fluid communication with pump 20. Pump 20 can be in electrical communication with a remote control 22 via control box 24. Remote control 22 can communicate via wired or wireless means with control box 24. Control box 24 can be configured to operate pump 20 to cause increases and decreases in the fluid pressure of first and second air chambers 14A and 14B based upon commands input by a user through remote control 22. Remote control 22 can include display 26, output selecting means 28, pressure increase button 29, and pressure decrease button 30. Output selecting means 28 can allow the user to switch the pump output between the first and second air chambers 14A and 14B, thus enabling control of multiple air chambers with a single remote control 22. For example, output selecting means may be a physical control (e.g., switch or button) or an input control displayed on display 26. Alternatively, separate remote control units can be provided for each air chamber and may each include the ability to control multiple air chambers. Pressure increase and decrease buttons 29 and 30 can allow a user to increase or decrease the pressure, respectively, in the air chamber se-

lected with the output selecting means 28. Adjusting the pressure within the selected air chamber can cause a corresponding adjustment to the firmness of the air chamber.

[0007] FIG. 2 is a block diagram detailing data communication between certain components of air bed system 10 according to various examples. As shown in FIG. 2, control box 24 can include power supply 34, processor 36, memory 37, switching means 38, analog to digital (A/D) converter 40, and radios for communication with remotes and smartphones. Switching means 38 can be, for example, a relay or a solid state switch. Switching means 38 can be located in the pump 20 rather than the control box 24.

[0008] Pump 20 and remote control 22 can be in two-way communication with the control box 24. Pump 20 can include a motor 42, a pump manifold 43, a relief valve 44, a first control valve 45A, a second control valve 45B, and a pressure transducer 46, and can be fluidly connected with the first air chamber 14A and the second air chamber 14B via a first tube 48A and a second tube 48B, respectively. First and second control valves 45A and 45B can be controlled by switching means 38, and can be operable to regulate the flow of fluid between pump 20 and first and second air chambers 14A and 14B, respectively.

[0009] In an example, pump 20 and control box 24 can be provided and packaged as a single unit. Alternatively, pump 20 and control box 24 can be provided as physically separate units.

[0010] In operation, power supply 34 can receive power, such as 110 VAC power, from an external source and can convert the power to various forms required by certain components of the air bed system 10. Processor 36 can be used to control various logic sequences associated with operation of the air bed system 10, as will be discussed in further detail below.

[0011] The example of the air bed system 10 shown in FIG. 2 contemplates two air chambers 14A and 14B and a single pump 20. However, other examples may include an air bed system having two or more air chambers and one or more pumps incorporated into the air bed system to control the air chambers. In an example, a separate pump may be associated with each air chamber of the air bed system or a pump may be associated with multiple chambers of the air bed system. Separate pumps may allow each air chamber to be inflated or deflated independently and simultaneously. Furthermore, additional pressure transducers may also be incorporated into the air bed system such that, for example, a separate pressure transducer may be associated with each air chamber.

[0012] In the event that the processor 36 sends a decrease pressure command to one of air chambers 14A or 14B, switching means 38 can be used to convert the low voltage command signals sent by processor 36 to higher operating voltages sufficient to operate relief valve 44 of pump 20 and open control valves 45A or 45B. Open-

ing relief valve 44 can allow air to escape from air chamber 14A or 14B through the respective air tube 48A or 48B. During deflation, pressure transducer 46 can send pressure readings to processor 36 via the A/D converter 40. The A/D converter 40 can receive analog information from pressure transducer 46 and can convert the analog information to digital information useable by processor 36. Processor 36 may send the digital signal to remote control 22 to update display 26 on the remote control in order to convey the pressure information to the user

[0013] In the event that processor 36 sends an increase pressure command, pump motor 42 can be energized, sending air to the designated air chamber through air tube 48A or 48B via electronically operating corresponding valve 45A or 45B. While air is being delivered to the designated air chamber in order to increase the firmness of the chamber, pressure transducer 46 can sense pressure within pump manifold 43. Again, pressure transducer 46 can send pressure readings to processor 36 via A/D converter 40. Processor 36 can use the information received from A/D converter 40 to determine the difference between the actual pressure in air chamber 14A or 14B and the desired pressure. Processor 36 can send the digital signal to remote control 22 to update display 26 on the remote control in order to convey the pressure information to the user.

[0014] Generally speaking, during an inflation or deflation process, the pressure sensed within pump manifold 43 provides an approximation of the pressure within the air chamber. An example method of obtaining a pump manifold pressure reading that is substantially equivalent to the actual pressure within an air chamber is to turn off pump 20, allow the pressure within the air chamber 14A or 14B and pump manifold 43 to equalize, and then sense the pressure within pump manifold 43 with pressure transducer 46. Thus, providing a sufficient amount of time to allow the pressures within pump manifold 43 and chamber 14A or 14B to equalize may result in pressure readings that are accurate approximations of the actual pressure within air chamber 14A or 14B. In various examples, the pressure of 48A/B is continuously monitored using multiple pressure sensors

[0015] In an example, another method of obtaining a pump manifold pressure reading that is substantially equivalent to the actual pressure within an air chamber is through the use of a pressure adjustment algorithm. In general, the method can function by approximating the air chamber pressure based upon a mathematical relationship between the air chamber pressure and the pressure measured within pump manifold 43 (during both an inflation cycle and a deflation cycle), thereby eliminating the need to turn off pump 20 in order to obtain a substantially accurate approximation of the air chamber pressure. As a result, a desired pressure setpoint within air chamber 14A or 14B can be achieved without the need for turning pump 20 off to allow the pressures to equalize. The latter method of approximating an air chamber pressure using mathematical relationships between the air

chamber pressure and the pump manifold pressure is described in detail in U.S. Application Serial No. 12/936,084.

[0016] FIG. 3 illustrates an example air bed system architecture 300. Architecture 300 includes bed 301, central controller 302, firmness controller 304, articulation controller 306, temperature controller 308, external network device 310, remote controllers 312, 314, and voice controller 316. While described as using an air bed, the system architecture may also be used with other types of beds.

[0017] As illustrated in FIG. 3, network bed architecture 300 is configured as a star topology with central controller 302 and firmness controller 304 functioning as the hub and articulation controller 306, temperature controller 308, external network device 310, remote controls 312, 314, and voice controller 316 functioning as possible spokes, also referred to herein as components. Thus, in various examples, central controller 302 acts a relay between the various components.

[0018] In other examples, different topologies may be used. For example, the components and central controller 302 may be configured as a mesh network in which each component may communicate with one or all of the other components directly, bypassing central controller 302. In various examples, a combination of topologies may be used. For example, remote controller 312 may communicate directly to temperature controller 308 but also relay the communication to central controller 302.

[0019] In yet another example, central controller 302 listens to communications (e.g., control signals) between components even if the communication is not being relayed through central controller 302. For example, consider a user sending a command using remote 312 to temperature controller 308. Central controller 302 may listen for the command and check to determine if instructions are stored at central controller 302 to override the command (e.g., it conflicts with a previous setting). Central controller 302 may also log the command for future use (e.g., determining a pattern of user preferences for the components).

[0020] In various examples, the controllers and devices illustrated in FIG. 3 may each include a processor, a storage device, and a network interface. The processor may be a general purpose central processing unit (CPU) or application-specific integrated circuit (ASIC). The storage device may include volatile or non-volatile static storage (e.g., Flash memory, RAM, EPROM, etc.). The storage device may store instructions which, when executed by the processor, configure the processor to perform the functionality described herein. For example, a processor of firmness control 304 may be configured to send a command to a relief valve to decrease the pressure in a bed.

[0021] In various examples, the network interface of the components may be configured to transmit and receive communications in a variety of wired and wireless protocols. For example, the network interface may be configured to use the 802.11 standards (e.g.,

802.11a/b/c/g/n/ac), PAN network standards such as 802.15.4 or Bluetooth, infrared, cellular standards (e.g., 3G/4G etc.), Ethernet, and USB for receiving and transmitting data. The previous list is not intended to exhaustive and other protocols may be used. Not all components of FIG. 3 need to be configured to use the same protocols. For example, remote control 312 may communicate with central controller 302 via Bluetooth while temperature controller 308 and articulation controller 306 are connected to central controller using 802.15.4. Within FIG. 3, the lightning connectors represent wireless connections and the solid lines represent wired connections, however, the connections between the components is not limited to such connections and each connection may be wired or wireless.

[0022] Moreover, in various examples, the processor, storage device, and network interface of a component may be located in different locations than various elements used to effect a command. For example, as in FIG. 1, firmness controller 302 may have a pump that is housed in a separate enclosure than the processor used to control the pump. Similar separation of elements may be employed for the other controllers and devices in FIG. 3.

[0023] In various examples, firmness controller 304 is configured to regulate pressure in an air mattress. For example, firmness controller 304 may include a pump such as described with reference to FIG. 2 (see e.g., pump 20). Thus, in an example, firmness controller 304 may be respond to commands to increase or decrease pressure in the air mattress. The commands may be received from another component or based on stored application instruction that are part of firmness controller 304.

[0024] As illustrated in FIG. 3 central controller 302 includes firmness controller 304. Thus, in an example, the processor of central controller 302 and firmness control 304 may be the same processor. Furthermore, the pump may also be part of central controller 302. Accordingly, central controller 302 may be responsible for pressure regulation as well as other functionality as described in further portions of this disclosure.

[0025] In various examples, articulation controller 306 is configured to adjust the position of a bed (e.g., bed 301) by adjusting the foundation that supports the bed. In an example, separate positions may be set for two different beds (e.g., two twin beds placed next to each other). The foundation may include more than one zone that may be independently adjusted. Articulation control 306 may also be configured to provide different levels of massage to a person on the bed.

[0026] In various examples, temperature controller 308 is configured to increase, decrease, or maintain the temperature of a user. For example, a pad may be placed on top of or be part of the air mattress. Air may be pushed through the pad and vented to cool off a user of the bed. Conversely, the pad may include a heating element that may be used to keep the user warm. In various examples,

temperature controller 308 receives temperature readings from the pad.

[0027] In various examples, additional controllers may communicate with central controller 302. These controllers may include, but are not limited to, illumination controllers for turning on and off light elements placed on and around the bed and outlet controllers for controlling power to one or more power outlets.

[0028] In various examples, external network device 310, remote controllers 312, 314 and voice controller 316 may be used to input commands (e.g., from a user or remote system) to control one or more components of architecture 300. The commands may be transmitted from one of the controllers 312, 314, or 316 and received in central controller 302. Central controller 302 may process the command to determine the appropriate component to route the received command. For example, each command sent via one of controllers 312, 314, or 316 may include a header or other metadata that indicates which component the command is for. Central controller 302 may then transmit the command via central controller 302's network interface to the appropriate component.

[0029] For example, a user may input a desired temperature for the user's bed into remote control 312. The desired temperature may be encapsulated in a command data structure that includes the temperature as well as identifies temperature controller 308 as the desired component to be controlled. The command data structure may then be transmitted via Bluetooth to central controller 302. In various examples, the command data structure is encrypted before being transmitted. Central controller 302 may parse the command data structure and relay the command to temperature controller 308 using a PAN. Temperature controller 308 may be then configure its elements to increase or decrease the temperature of the pad depending on the temperature originally input into remote control 312.

[0030] In various examples, data may be transmitted from a component back to one or more of the remote controls. For example, the current temperature as determined by a sensor element of temperature controller 308, the pressure of the bed, the current position of the foundation or other information may be transmitted to central controller 302. Central controller 302 may then transmit the received information and transmit it to remote control 312 where it may be displayed to the user.

[0031] In various examples, multiple types of devices may be used to input commands to control the components of architecture 300. For example, remote control 312 may be a mobile device such as a smart phone or tablet computer running an application. Other examples of remote control 312 may include a dedicated device for interacting with the components described herein. In various examples, remote controls 312/314 include a display device for displaying an interface to a user. Remote control 312/314 may also include one or more input devices. Input devices may include, but are not limited to, keypads, touchscreen, gesture, motion and voice controls.

[0032] Remote control 314 may be a single component remote configured to interact with one component of the mattress architecture. For example, remote control 314 may be configured to accept inputs to increase or decrease the air mattress pressure. Voice controller 316 may be configured to accept voice commands to control one or more components. In various examples, more than one of the remote controls 312/314 and voice controller 316 may be used.

[0033] With respect to remote control 312, the application may be configured to pair with one or more central controllers. For each central controller, data may be transmitted to the mobile device that includes a list of components linked with the central controller. For example, consider that remote control 312 is a mobile phone and that the application has been authenticated and paired with central controller 302. Remote control 312 may transmit a discovery request to central controller 302 to inquire about other components and available services. In response, central controller 302 may transmit a list of services that includes available functions for adjusting the firmness of the bed, position of the bed, and temperature of the bed. In various embodiments, the application may then display functions for increasing/decreasing pressure of the air mattress, adjusting positions of the bed, and adjusting temperature. If components are added/removed to the architecture under control of central controller 302, an updated list may be transmitted to remote control 312 and the interface of the application may be adjusted accordingly.

[0034] In various examples, central controller 302 is configured as a distributor of software updates to components in architecture 300. For example, a firmware update for temperature controller 308 may become available. The update may be loaded into a storage device of central controller 302 (e.g., via a USB interface or wireless techniques). In wireless applications, the central controller 302 may, for example, receive updates from the cloud either from Wi-Fi or from a mobile connection over Bluetooth. Central controller 302 may then transmit the update to temperature controller 308 with instructions to update. Temperature controller 308 may attempt to install the update. A status message may be transmitted from temperature controller 308 to central controller 302 indicating the success or failure of the update.

[0035] In various examples, central controller 302 is configured to analyze data collected by a pressure transducer (e.g., transducer 46 with respect to FIG. 2) to determine various states of a person lying on the bed. For example, central controller 302 may determine the heart rate or respiration rate of a person lying in the bed. Additional processing may be done using the collected data to determine a possible sleep state of the person. For example, central controller 302 may determine when a person falls asleep and, while asleep, the various sleep states of the person.

[0036] In various example, external network device 310 includes a network interface to interact with an ex-

ternal server for processing and storage of data related to components in architecture 300. For example, the determined sleep data as described above may be transmitted via a network (e.g., the Internet) from central controller 302 to external network device 310 for storage. In an example, the pressure transducer data may be transmitted to the external server for additional analysis. The external network device 310 may also analyze and filter the data before transmitting it to the external server.

[0037] In an example, diagnostic data of the components may also be routed to external network device 310 for storage and diagnosis on the external server. For example, if temperature controller 308 detects an abnormal temperature reading (e.g., a drop in temperature over one minute that exceeds a set threshold) diagnostic data (sensor readings, current settings, etc.) may be wirelessly transmitted from temperature controller 308 to central controller 302. Central controller 302 may then transmit this data via USB to external network device 310. External device 310 may wirelessly transmit the information to an WLAN access point where it is routed to the external server for analysis.

[0038] In various examples, the pressure in the air mattress may adjust without additional user input. For example, one or more components of the air bed system architecture may detect that a user is no longer present on the air mattress and increase the pressure to the maximum pressure allowed by the air mattress or adjust the pressure in response to environmental factors.

[0039] FIG. 4 is a flowchart of method 400 to automatically increase the pressure of an air mattress, according to various examples. For labeling purposes, and not by way of limitation, method 400 is referred to herein as the "auto-fill" method or feature. The operations of method 400 are described as being performed on central controller 302. For example, firmness controller 304 may store the preferences and determine if the auto-fill feature should be engaged as further described below. In various examples, central controller 302 acts as a relay of the preferences as described with respect to FIG. 3.

[0040] At block 402, in various examples, user preferences related to the auto-fill method are received at central controller 302. The preferences may be received from one or more of remotes 312, 314, and 316. For example, using an application running on smart phone app 312, a user interface (UI) may be presented to the user. The UI may include input indicia (check boxes, radio buttons, input forms, etc.) for the preferences related to the auto-fill method. A user may interact (e.g., click, activate) with the input indicia to set the preferences. The preferences may be stored in a storage device of remote 312 or transmitted to central controller 302 for storage. In various examples, the preferences may be stored in a database (relational, non-relational, flat file, etc.) or in a structured file (e.g., XML). The preferences may also have default values if the user does not input a value. In various examples, not all of the preferences are shown to a user.

[0041] In various examples, the preferences may in-

clude an enabling preference, a delay preference, a time preference, and an auto-fill pressure preference. In an example, the enabling preference is a Boolean representing the user's preference to use the auto-fill feature. While three preferences are described, various examples may use less than all three preferences; for example, only the enabling preference may be used. If the enabling preference indicates that the user does not want to use the auto-fill feature, the remaining preferences may not be shown or not be selectable by the user.

[0042] In an example, the delay preference is a threshold that indicates the user's preference for when the auto-fill feature should be engaged. For example, the auto-fill feature may turn on when no one has been on the bed for 15 minutes. The delay preference may be set in a variety of times units including seconds, minutes, and hours.

[0043] In an example, the time preference indicates one or more time periods of day when the auto-fill feature can be used. For example, the user may indicate that from 9:00 AM to 5:00 PM the auto-fill feature can be used. Thus, if during the set time period the other auto-fill conditions are met, then the air mattress may auto-fill to the set pressure. If the conditions are otherwise met, but the current time of day is not within the user's defined period, auto-filling may not occur.

[0044] In an example, the auto-fill pressure preference is a numerical value associated with a pressure of the air mattress to use when the auto-fill feature is engaged. The auto-fill pressure may be limited to a range (e.g., 0-100). For example, a "100" setting may be the maximum pressure allowed in the air mattress as indicated in a storage device of central controller 302 or firmness controller 304. This setting may be used, for example, when the user wants to have a full bed for easier bed making. A '0' setting may be the lowest allowable pressure as indicated in a storage device of central controller 302 or firmness controller 304. Thus, a '0' setting may not directly correlate to having no pressure in the air mattress.

[0045] At block 404, in an example, central controller 302 receives an indication that nobody is on an air mattress (e.g., unoccupied). The indication may be received from a variety of sources. For example, firmness controller 304 or central controller 302 may monitor the pressure of the air mattress and if a pressure change exceeds a threshold, firmness controller 304 may classify the change as an "empty bed" event - the label "empty bed" is used for illustration purposes only and other terms may be used without departing from the scope of this disclosure.

[0046] In various examples, central controller 302 may receive an indication from external network device 310 that an "empty bed" has been detected. For example, external network device 310 may process the pressure readings from transducer 46 to determine the presence of one or more people on the air mattress. Similarly, the pressure data may be transmitted to an external server for further processing. Based on the processing in exter-

nal network device 310 alone or in combination with the external server, external network device 310 may transmit data back to central controller 302 indicating whether or not a person is believed to be on the air mattress.

[0047] In an example, central controller 302 may detect user presence via gross pressure changes. For example, the central controller 302 and pressure transducer 46 (of FIG. 2) may be used to monitor the air pressure in the air mattress of bed 301. If the user sits or lies down on the air mattress, the air pressure in the air mattress changes, e.g., increases, due to the additional weight of the user, which results in a gross pressure change. Central controller 302 may determine whether the user is now on the bed based on the gross pressure change, e.g., over some time period. For example, by determining a rate of change of pressure, e.g., over one to ten minutes, and comparing the determined rate of change to a threshold value, central controller 302 may determine whether the user is now on the bed.

[0048] In an example implementation, central controller 302 may detect user presence using temperature changes detected in the mattress, e.g., using one or more temperature sensors positioned in or on the mattress. The temperature sensors and the central controller 302 may detect a rise in temperature, e.g., over a specified period of time, and determine that a user is present in the bed. For example, if central controller 302 detects a rise in temperature and then determines that the detected rise in temperature was not caused by the system's temperature controller 308, central controller 302 may determine that the user is present.

[0049] At block 406, in various examples, central controller 302 determines if the auto-fill feature should be engaged. For example, upon receiving the indication that nobody is the air mattress, an initial check may be made to determine if a user has enabled the auto-fill feature. The check may be done by accessing the preference as stored on a storage device. If the feature is not enabled then method 400 may end.

[0050] In various examples, if a time preference has not been set by the user, central controller 302 may start a timer. Conversely, if a time preference has been set, central controller 302 may determine if the time of day when the indication was received at central controller 302 is within the time window as set by the user. If the time is within the window, the timer may start. In various examples, if the time the indication is received is not in the timer period, but as time passes the time enters the time preference window, the timer may start.

[0051] In various examples, the timer increments until either the threshold time as indicated by the delay preference is reached or an indication is received (e.g., at central controller 302) that a presence has been detected on the bed. For example, if the delay preference is 15 minutes, upon the timer reaching 15 minutes, the auto-fill feature may be activated. If, however, an indication is received that someone is now on the bed, the timer may be reset to 0 and control may flow back to block 404.

Similarly, if someone gets off the bed and the time window closes before the timer has expired, the timer may be reset to 0.

[0052] In various examples, upon activation of the auto-fill feature, the bed may increase to the pressure as indicated in the auto-fill pressure preference. In an example, if no auto-fill pressure preference has been set, a default value of '100' may be used. The mechanism by which the pressure increases may include sending a signal to a pump as described herein. According to the invention, the automatic fill pressure level is maintained until receiving another pressure value (e.g., from a user or automated process).

[0053] FIG. 5 is a flowchart of method 500 to automatically adjust the pressure of an air mattress, according to various examples. For labeling purposes, and not by way of limitation, method 500 is referred to herein as the "auto-adjust" method or feature. Additionally, while many of the operations of method 500 are described as being performed on central controller 302, other components may be used. For example, firmness controller 304 may monitor the pressure and determine if the pressure should be adjusted as further described below. In various examples, central controller 302 acts as a relay of the preferences as described with respect to FIG. 3.

[0054] A user may have initially set the pressure of an air mattress (e.g., using one or more remotes as described herein) to a value of "50." The user set value may correspond to a PSI level of the air mattress. Thus, after a user sets the value, the user may expect the air mattress to feel the same the next time he or she sleeps on the bed. However, due to environmental changes (e.g., temperature, pressure of the air in the room) or possible mechanical failures (e.g., a leak) the pressure in the air mattress may change over time. Thus, the user may feel the need to increase the value to achieve the same pressure. In various examples, method 500 automatically adjust the pressure in the air mattress to maintain pressure within a specified range to compensate for these environmental and possible mechanical factors such that the when the user sleeps in the bed from night to night the bed maintains the same pressure.

[0055] At block 502, in various examples, user preferences related to the auto-adjust method are received at central controller 302. The preferences may be received from one or more of remotes 312, 314, and 316. For example, using an application running on smart phone app 312, a user interface (UI) may be presented to the user. The UI may include input indicia (check boxes, radio buttons, input forms, etc.) for the preferences related to the auto-adjust method. A user may interact with the input indicia to set the preferences. The preferences may be stored in a storage device of remote 312 or transmitted to central controller 302 for storage. In various examples, the preferences may be stored in a database (relational, non-relational, flat file, etc.) or in a structured file (e.g., XML). The preferences may also have default values if the user does not input a value. In various examples, not

all of the preferences are shown to a user. For example, the auto-adjust feature may not be user modified in any way (i.e., it is a feature of the bed that the user may not turn off).

[0056] In various examples, the preferences may include an enabling preference, a time preference, and a delay preference. While three preferences are described, various examples may use less than all three preferences. In an example, the enabling preference is a Boolean representing the user's preference to use the auto-adjust feature. If the enabling preference indicates that the user does not want to use the auto-adjust feature, the remaining preferences may not be shown or not be selectable by the user.

[0057] In an example, the time preference indicate one or more time periods of day when the auto-adjust feature can be used. For example, the user may indicate that from 9:00 AM to 5:00 PM the auto-adjust feature can be used. Thus, if during the set time period that other auto-adjust conditions are met, then the air mattress may auto-adjust the pressure in the bed. If the conditions are otherwise met, but the current time of day is not within the user's defined period, auto-adjusting will not occur. In an example, an option is presented to the user to always have the auto-adjust feature enabled regardless of the time of day.

[0058] In an example, the delay preference is a threshold that indicates the user's preference for when the auto-adjust feature should be engaged. For example, the auto-adjust feature may turn on when no one has been on the bed for 15 minutes. The delay preference may be set in a variety of times units, including seconds, minutes, and hours.

[0059] At block 504, in an example, central controller 302 receives an indication that nobody is on an air mattress. The indication may be received from a variety of sources. For example, firmness controller 304 or central controller 302 may monitor the pressure of the air mattress and if a pressure change exceeds a threshold, firmness controller 304 may classify the change as an "empty bed" event - the label "empty bed" is used for illustration purposes only and other terms may be used without departing from the scope of this disclosure.

[0060] In various examples, central controller 302 receives an indication from external network device 310 that an "empty bed" has been detected. For example, external network device 310 may process the pressure readings from transducer 46 to determine the presence of one or more people on the air mattress. Similarly, the pressure data may be transmitted to an external server for further processing. Based on the processing in external network device 310 alone or in combination with the external server, external network device 310 may transmit data back to central controller 302 indicating whether or not a person is believed to be on the air mattress.

[0061] At block 506, in various embodiments, the pressure of the bed is monitored (e.g., via the transducer of the air mattress) when it is indicated that no one is on

the bed. This may be done, for example, by central controller 302. Central controller 302 may use a baseline pressure reading (e.g., the pressure that correlates to the user set value) and compare it to pressure readings when no one is on the bed. For example, every minute a pressure reading may be received at central controller 302 and compared to the baseline pressure reading.

[0062] At block 508, in various examples, it is determined if the auto-adjust feature should be activated. For example, upon receiving the indication that nobody is the air mattress, an initial check may be made to determine if a user has enabled the auto-adjust feature. The check may be done by accessing the preference as stored on a storage device. If the feature is not enabled then method 500 may end.

[0063] In various examples, if a time preference has not been set by the user, central controller 302 may start a timer. Conversely, if a time preference has been set, central controller 302 may determine if the time of day when the indication was received at central controller 302 is within the time window as set by the user. If the time is within the window, the timer may start. In various examples, if the time the indication is received is not in the timer period, but as time passes the time enters the time preference window, the timer may start.

[0064] In various examples, the timer increments until either the threshold time as indicated by the delay preference is reached or an indication is received (e.g., at central controller 302) that a presence has been detected on the bed. For example, if the delay preference is 15 minutes, upon the timer reaching 15 minutes, the auto-adjust feature may be activated. If, however, an indication is received that someone is now on the bed, the timer may be reset to 0 and control may flow back to block 504. Similarly, if someone gets off the bed and the time window closes before the timer has expired, the timer may be reset to 0.

[0065] In various examples, assuming the conditions of the user preferences have been met, central controller 302 determines if the difference between the baseline reading and sampled reading has changed beyond a set threshold (e.g., 2 PSI). If the pressure exceeds the threshold, central controller 302 may send a signal to the pump to increase/decrease the pressure back to the baseline. In various examples, there is a second timer that is used before the signal is sent. For example, the difference may need to exceed the threshold for at least 5 minutes before sending the signal. In various examples, the time period at which the pressure is sampled, the second timer value, and the threshold change may be modified by user input (e.g., a technician) or via software updates.

[0066] In various examples, if the user has activated both the auto-adjust and auto-fill features there may be a conflict. For example, if a user has a pressure value of "50" and if the pressure in the air-mattress is set to 100 via the auto-fill feature, the pressure may be higher than the threshold change for the auto-adjust feature which

may in turn lower the pressure. In an example, if the pressure change is due to a user set feature, the auto-adjust feature may be disabled. A notification may be displayed to the user on one or more of the remotes indicating that the auto-adjust feature is not available with auto-fill. In an example, at the time the user is setting preferences for these features, if there is an incompatibility detected a prompt may be displayed alerting the user to change one or more of the settings.

[0067] In various examples, architecture provides additional features based on presence detection. For example, central controller 302 may detect that an air mattress is leaking (e.g., by detecting pressure changes despite environmental factors staying the same) and increase air flow to an air chamber to compensate. Additionally, central controller 302 may transmit an electronic message to a person when a user leaves the bed (e.g., a caregiver may be notified that a patient is out of bed). If the bed is being used in a hospitality setting, a maid service may be notified when a person has gotten out of bed. Settings for the above features may be set in a similar fashion as described above with respect to the auto-adjust and auto-fill features.

[0068] In another example, an auto-restore feature may be offered such that when the architecture detects a user is back in bed past a certain time at night (e.g., a user changeable time) architecture 300 may automatically change any component settings back to the way they were the night before. In such a way, a user may change components throughout the day, and system 300 may automatically set them back to a "sleep" state, based on the previous night or stored user preference, when the user gets back into bed to sleep for the night.

EXAMPLE MACHINE ARCHITECTURE AND MACHINE-READABLE MEDIUM

[0069] FIG. 6 is a block diagram of machine in the example form of a computer system 600 within which instructions, for causing the machine to perform any one or more of the methodologies discussed herein, may be executed. In alternative embodiments, the machine operates as a standalone device or may be connected (e.g., networked) to other machines. In a networked deployment, the machine may operate in the capacity of a server or a client machine in server-client network environment, or as a peer machine in a peer-to-peer (or distributed) network environment. The machine may be a personal computer (PC), a tablet PC, a set-top box (STB), a Personal Digital Assistant (PDA), a cellular telephone, a web appliance, a network router, switch or bridge, or any machine capable of executing instructions (sequential or otherwise) that specify actions to be taken by that machine. Further, while only a single machine is illustrated, the term "machine" shall also be taken to include any collection of machines that individually or jointly execute a set (or multiple sets) of instructions to perform any one or more of the methodologies discussed herein.

[0070] The example computer system 600 includes a processor 602 (e.g., a central processing unit (CPU), a graphics processing unit (GPU), ASIC or a combination), a main memory 604 and a static memory 606, which communicate with each other via a bus 608. The computer system 600 may further include a video display unit 610 (e.g., a liquid crystal display (LCD) or a cathode ray tube (CRT)). The computer system 600 also includes an alphanumeric input device 612 (e.g., a keyboard, touch-screen), a user interface (UI) navigation device 614 (e.g., a mouse), a disk drive unit 616, a signal generation device 618 (e.g., a speaker) and a network interface device 620.

MACHINE-READABLE MEDIUM

[0071] The disk drive unit 616 includes a machine-readable medium 622 on which is stored one or more sets of instructions and data structures (e.g., software) 624 embodying or utilized by any one or more of the methodologies or functions described herein. The instructions 624 may also reside, completely or at least partially, within the main memory 604 and/or within the processor 602 during execution thereof by the computer system 600, the main memory 604 and the processor 602 also constituting machine-readable media.

[0072] While the machine-readable medium 622 is shown in an example embodiment to be a single medium, the term "machine-readable medium" may include a single medium or multiple media (e.g., a centralized or distributed database, and/or associated caches and servers) that store the one or more instructions or data structures. The term "machine-readable medium" shall also be taken to include any tangible medium that is capable of storing, encoding or carrying instructions for execution by the machine and that cause the machine to perform any one or more of the methodologies of the present invention, or that is capable of storing, encoding or carrying data structures utilized by or associated with such instructions. The term "machine-readable medium" shall accordingly be taken to include, but not be limited to, solid-state memories, and optical and magnetic media. Specific examples of machine-readable media include non-volatile memory, including by way of example semiconductor memory devices, e.g., Erasable Programmable Read-Only Memory (EPROM), Electrically Erasable Programmable Read-Only Memory (EEPROM), and flash memory devices; magnetic disks such as internal hard disks and removable disks; magneto-optical disks; and CD-ROM and DVD-ROM disks.

TRANSMISSION MEDIUM

[0073] The instructions 624 may further be transmitted or received over a communications network 626 using a transmission medium. The instructions 624 may be transmitted using the network interface device 620 and any one of a number of well-known transfer protocols (e.g., HTTP). Examples of communication networks include a

local area network ("LAN"), a wide area network ("WAN"), the Internet, mobile telephone networks, Plain Old Telephone (POTS) networks, and wireless data networks (e.g., WiFi and WiMax networks). The term "transmission medium" shall be taken to include any intangible medium that is capable of storing, encoding or carrying instructions for execution by the machine, and includes digital or analog communications signals or other intangible media to facilitate communication of such software.

[0074] Although an embodiment has been described with reference to specific example embodiments, it will be evident that various modifications and changes may be made to these embodiments without departing from the scope of the invention. Accordingly, the specification and drawings are to be regarded in an illustrative rather than a restrictive sense. The accompanying drawings that form a part hereof, show by way of illustration, and not of limitation, specific embodiments in which the subject matter may be practiced. The embodiments illustrated are described in sufficient detail to enable those skilled in the art to practice the teachings disclosed herein.

Claims

1. A method comprising:

receiving, at a central controller (304), a user preference condition for an automatic fill feature of an air mattress having at least one air chamber (14);

receiving, at the central controller (304), an indication that the air mattress is unoccupied; and based on determining that the user preference condition has been met and receiving the indication that the air mattress is unoccupied:

transmitting a signal to a pump (20) to increase the pressure of the air mattress to an automatic fill pressure level; and maintaining the automatic fill pressure level in the air mattress until another pressure value is received.

2. The method of claim 1, further comprising:

receiving a user pressure preference identifying the automatic fill pressure level.

3. The method of claim 1 further comprising detecting the air mattress is unoccupied based on gross pressure changes in the air pressure of the air mattress by determining a change of pressure over a period of time and comparing the determined rate of change to a threshold value.

4. The method of claim 1, wherein the user preference condition is a time preference identifying a time pe-

riod when the automatic fill feature can be engaged, wherein the automatic fill feature will not be engaged at a time that is not within the identified time period.

5 **5.** The method of claim 4, wherein the user preference is a delay preference identifying a threshold time period to pass after receiving the indication that the air mattress is unoccupied before engaging the automatic fill feature, wherein the automatic fill feature is engaged when no one has been on the bed for the threshold time period.

10 **6.** The method of claim 1, wherein the automatic fill pressure level is maintained until another pressure value is received in an automated process.

15 **7.** The method of claim 1, wherein the automatic fill pressure level is maintained until another pressure value is received from the user.

20 **8.** The method of claim 1, wherein the user preference condition for the automatic fill feature of the air mattress is received via a user interface of an application running on smart phone, the method further comprising:

25 making a check to determine if the user has enabled the automatic fill feature by accessing the user preference condition for the automatic fill feature in response to receiving the indication that the air mattress is unoccupied.

9. A system comprising:

30 an air mattress with at least one chamber; a pump; a central controller; at least one processor; a storage device including instructions, which when executed by the at least one processor, configure the at least one processor to:

35 transmit a signal to the pump (20) of the air mattress to set the pressure of the air mattress to an initial pressure;

40 receive, at the central controller (304), a user preference condition for an automatic adjustment feature of the pressure in the air mattress;

45 receive, at the central controller (304), an indication that the air mattress is unoccupied; and

50 based on determining that the user preference condition has been met and receiving, at the central controller (304), the indication that the air mattress is unoccupied; detect, at the central controller (304), whether a change in the pressure of the air mattress is beyond a threshold value;

- based on the detection, adjust, by transmitting a signal from the central controller (302) to the pump (20), the pressure of the air mattress back to the initial pressure if the change in the pressure is detected to exceed the threshold value; and maintain the pressure in the air mattress at the initial pressure.
10. The system of claim 9, wherein the user preference condition is a time preference identifying a time period when the automatic adjustment feature is to be engaged, wherein the automatic adjustment feature will not be engaged at a time that is not within the identified time period.
11. The system of claim 10, wherein the user preference is a delay preference identifying a threshold time period to pass after receiving the indication that the air mattress is unoccupied before engaging the automatic adjustment feature, wherein the automatic adjustment feature is engaged when no one has been on the bed for the threshold time period.
12. The system of claim 9, wherein the at least one processor is further configured to detect the air mattress is unoccupied based on gross pressure changes in the air pressure of the air mattress.
13. The system of claim 9, wherein the at least one processor is further configured to detect, at the central controller (304), the air mattress is unoccupied based on temperature changes, in the air mattress.

Patentansprüche

1. Verfahren, umfassend:

Empfangen, an einer zentralen Steuerung (304), einer Benutzerpräferenzbedingung für eine automatische Füllfunktion einer Luftmatratze, die wenigstens eine Luftkammer (14) aufweist;

Empfangen, an der zentralen Steuerung (304), einer Anzeige, dass die Luftmatratze nicht belegt ist; und

basierend auf der Bestimmung, dass die Benutzerpräferenzbedingung erfüllt ist, und dem Empfangen der Anzeige, dass die Luftmatratze nicht belegt ist:

Senden eines Signals an eine Pumpe (20), um den Druck in der Luftmatratze auf ein automatisches Fülldruckniveau zu erhöhen; und

Beibehalten des automatischen Fülldruckniveaus in der Luftmatratze, bis ein anderer

Druckwert empfangen wird.

2. Verfahren nach Anspruch 1, ferner umfassend:

Empfangen einer Benutzerdruckpräferenz, die das automatische Fülldruckniveau angibt.

3. Verfahren nach Anspruch 1, ferner umfassend zu erkennen, dass die Luftmatratze nicht belegt ist, basierend auf Brutto-Druckänderungen des Luftdrucks der Luftmatratze durch Bestimmen einer Änderung des Drucks über einen Zeitraum und Vergleichen der bestimmten Änderungsrate mit einem Schwellwert.

4. Verfahren nach Anspruch 1, wobei die Benutzerpräferenzbedingung eine Zeitpräferenz ist, die einen Zeitraum bezeichnet, wann die automatische Füllfunktion eingeschaltet werden kann, wobei die automatische Füllfunktion nicht zu einem Zeitpunkt eingeschaltet wird, der nicht innerhalb des angegebenen Zeitraums liegt.

5. Verfahren nach Anspruch 4, wobei die Benutzerpräferenz eine Wartezeitpräferenz ist, die einen Schwellwertzeitraum angibt, der nach Empfang der Anzeige, dass die Luftmatratze nicht belegt ist, verstreichen muss, ehe die automatische Füllfunktion eingeschaltet wird, wobei die automatische Füllfunktion eingeschaltet wird, wenn für den Schwellwertzeitraum niemand auf dem Bett gelegen hat.

6. Verfahren nach Anspruch 1, wobei in einem automatisierten Prozess das automatische Fülldruckniveau gehalten wird, bis ein anderer Druckwert empfangen wird.

7. Verfahren nach Anspruch 1, wobei das automatische Fülldruckniveau gehalten wird, bis vom Benutzer ein anderer Druckwert empfangen wird.

8. Verfahren nach Anspruch 1, wobei die Benutzerpräferenzbedingung für die automatische Füllfunktion der Luftmatratze über eine Benutzerschnittstelle einer Anwendung empfangen wird, die auf einem Smartphone läuft, wobei das Verfahren ferner umfasst:

Durchführen einer Prüfung, um zu bestimmen, ob der Benutzer die automatische Füllfunktion eingeschaltet hat, indem auf die Benutzerpräferenzbedingung für die automatische Füllfunktion zugegriffen wird, in Reaktion auf das Empfangen der Anzeige, dass die Luftmatratze nicht belegt ist.

9. System, umfassend:

eine Luftmatratze mit wenigstens einer Kammer;
 eine Pumpe;
 eine zentrale Steuerung;
 wenigstens einen Prozessor;
 eine Speichervorrichtung mit Anweisungen, die bei Ausführung durch den wenigstens einen Prozessor den wenigstens einen Prozessor konfigurieren zum:

Senden eines Signals an die Pumpe (20) der Luftmatratze, um den Druck der Luftmatratze auf einen Anfangsdruck einzustellen;
 Empfangen, an der zentralen Steuerung (304), einer Benutzerpräferenzbedingung für eine automatische Funktion zum Einstellen des Drucks in der Luftmatratze;
 Empfangen, an der zentralen Steuerung (304), einer Anzeige, dass die Luftmatratze nicht belegt ist; und
 basierend auf der Bestimmung, dass die Benutzerpräferenzbedingung erfüllt ist, und dem Empfangen, an der zentralen Steuerung (304), der Anzeige, dass die Luftmatratze nicht belegt ist:

Erkennen, an der zentralen Steuerung (304), ob eine Änderung des Drucks der Luftmatratze über einen Schwellwert hinausgeht;
 basierend auf der Erkennung Einstellen, durch Senden eines Signals von der zentralen Steuerung (302) an die Pumpe (20), des Drucks der Luftmatratze zurück auf den Anfangsdruck, wenn erkannt wird, dass die Änderung des Drucks den Schwellwert übersteigt; und
 Halten des Drucks in der Luftmatratze auf dem Anfangsdruck.

10. System nach Anspruch 9, wobei die Benutzerpräferenzbedingung eine Zeitpräferenz ist, die einen Zeitraum bezeichnet, wann die automatische Einstellfunktion eingeschaltet werden soll, wobei die automatische Einstellfunktion nicht zu einem Zeitpunkt eingeschaltet wird, der nicht innerhalb des angegebenen Zeitraums liegt.

11. System nach Anspruch 10, wobei die Benutzerpräferenz eine Wartezeitpräferenz ist, die einen Schwellwertzeitraum angibt, der nach Empfang der Anzeige, dass die Luftmatratze nicht belegt ist, verstreichen muss, ehe die automatische Einstellfunktion eingeschaltet wird, wobei die automatische Einstellfunktion eingeschaltet wird, wenn für den Schwellwertzeitraum niemand auf dem Bett gelegen hat.

12. System nach Anspruch 9, wobei der wenigstens eine Prozessor ferner dafür ausgelegt ist zu erkennen, dass die Luftmatratze nicht belegt ist, basierend auf Brutto-Druckänderungen im Luftdruck der Luftmatratze.

13. System nach Anspruch 9, wobei der wenigstens eine Prozessor ferner dafür ausgelegt ist zu erkennen, an der zentralen Steuerung (304), dass die Luftmatratze nicht belegt ist, basierend auf Temperaturänderungen in der Luftmatratze.

Revendications

1. Procédé comprenant :

la réception, au niveau d'un contrôleur central (304), d'une préférence d'utilisateur relative à un état d'une caractéristique de remplissage automatique d'un matelas pneumatique comportant au moins une chambre à air (14) ;
 la réception, au niveau du contrôleur central (304), d'une indication que le matelas pneumatique n'est pas occupé ; et
 en fonction de la détermination que la préférence d'utilisateur relative à l'état a été satisfaite et de la réception de l'indication que le matelas pneumatique n'est pas occupé :

la transmission d'un signal à une pompe (20) afin d'augmenter la pression du matelas pneumatique à un niveau de pression de remplissage automatique ; et
 le maintien du niveau de pression de remplissage automatique dans le matelas pneumatique jusqu'à réception d'une autre valeur de pression.

2. Procédé selon la revendication 1, comprenant en outre :

la réception d'une préférence d'utilisateur relative à la pression identifiant le niveau de pression de remplissage automatique.

3. Procédé selon la revendication 1 comprenant en outre la détection que le matelas pneumatique n'est pas occupé en fonction de changements de pression importants de la pression d'air du matelas pneumatiques en déterminant un changement de pression durant une période de temps et en comparant le taux de changement déterminé à une valeur de seuil.

4. Procédé selon la revendication 1, dans lequel la préférence d'utilisateur relative à l'état est une préférence de temps qui identifie une période de temps quand la caractéristique de remplissage automati-

que peut être lancée, dans lequel la caractéristique de remplissage automatique ne sera pas lancée à un temps qui n'est pas compris dans la période de temps identifiée.

5
10
15
20
25

5. Procédé selon la revendication 4, dans lequel la préférence d'utilisateur est une préférence de retard qui identifie une période de temps de seuil devant s'écouler après la réception de l'indication que le matelas pneumatique n'est pas occupé avant de lancer la caractéristique de remplissage automatique, dans lequel la caractéristique de remplissage automatique est lancée quand personne n'a reposé sur le matelas pendant la période de temps de seuil.

6. Procédé selon la revendication 1, dans lequel le niveau de pression de remplissage automatique est maintenu jusqu'à ce qu'une autre valeur de pression soit reçue dans un processus automatisé.

7. Procédé selon la revendication 1, dans lequel le niveau de pression de remplissage automatique est maintenu jusqu'à ce qu'une autre valeur de pression soit reçue de l'utilisateur.

8. Procédé selon la revendication 1, dans lequel la préférence d'utilisateur relative à l'état de la caractéristique de remplissage automatique du matelas pneumatique est reçue par l'intermédiaire d'une interface utilisateur d'une application exécutée sur un téléphone intelligent, le procédé comprenant en outre :

la réalisation d'une vérification pour déterminer que l'utilisateur a activé la caractéristique de remplissage automatique en accédant à la préférence d'utilisateur relative à l'état de la caractéristique de remplissage automatique en réponse à la réception de l'indication que le matelas pneumatique n'est pas occupé.

9. Système comprenant :

un matelas pneumatique comportant au moins une chambre ;
une pompe ;
un contrôleur central ;
au moins un processeur ;
un dispositif de mémorisation comportant des instructions, lesquelles, à leur exécution par l'au moins un processeur, configurent l'au moins un processeur pour :

transmettre un signal à la pompe (20) du matelas pneumatique pour régler la pression du matelas pneumatique à une pression initiale ;
recevoir, au niveau du contrôleur central (304), une préférence d'utilisateur relative

à l'état de la caractéristique de remplissage automatique de la pression dans le matelas pneumatique ;
recevoir, au niveau du contrôleur central (304), une indication que le matelas pneumatique n'est pas occupé ; et
en fonction de la détermination que la préférence d'utilisateur relative à l'état a été satisfaite et de la réception, au niveau du contrôleur central (304), de l'indication que le matelas pneumatique n'est pas occupé :

la détection, au niveau du contrôleur central (304), qu'un changement de pression du matelas pneumatique dépasse ou non une valeur de seuil ;
en fonction de la détection, l'ajustement, par transmission d'un signal depuis le contrôleur central (302) à la pompe (20) de la pression du matelas pneumatique pour la ramener à la pression initiale s'il est détecté que le changement de la pression dépasse la valeur de seuil ; et
le maintien de la pression dans le matelas pneumatique à la pression initiale.

10. Système selon la revendication 9, dans lequel la préférence d'utilisateur relative à l'état est une préférence de temps qui identifie une période de temps quand la caractéristique de remplissage automatique peut être lancée, dans lequel la caractéristique de remplissage automatique ne sera pas lancée à un temps qui n'est pas compris dans la période de temps identifiée.

11. Système selon la revendication 10, dans lequel la préférence d'utilisateur est une préférence de retard qui identifie une période de temps de seuil devant s'écouler après la réception de l'indication que le matelas pneumatique n'est pas occupé avant de lancer la caractéristique de remplissage automatique, dans lequel la caractéristique de remplissage automatique est lancée quand personne n'a reposé sur le matelas pendant la période de temps de seuil.

12. Système selon la revendication 9, dans lequel l'au moins un processeur est configuré en outre pour détecter que le matelas pneumatique n'est pas occupé en fonction de changements de pression importants de la pression d'air du matelas pneumatique.

13. Système selon la revendication 9, dans lequel l'au moins un processeur est configuré en outre pour détecter au niveau du contrôleur central (304), que le matelas pneumatique n'est pas occupé en fonction de changements de température dans le matelas pneumatique.

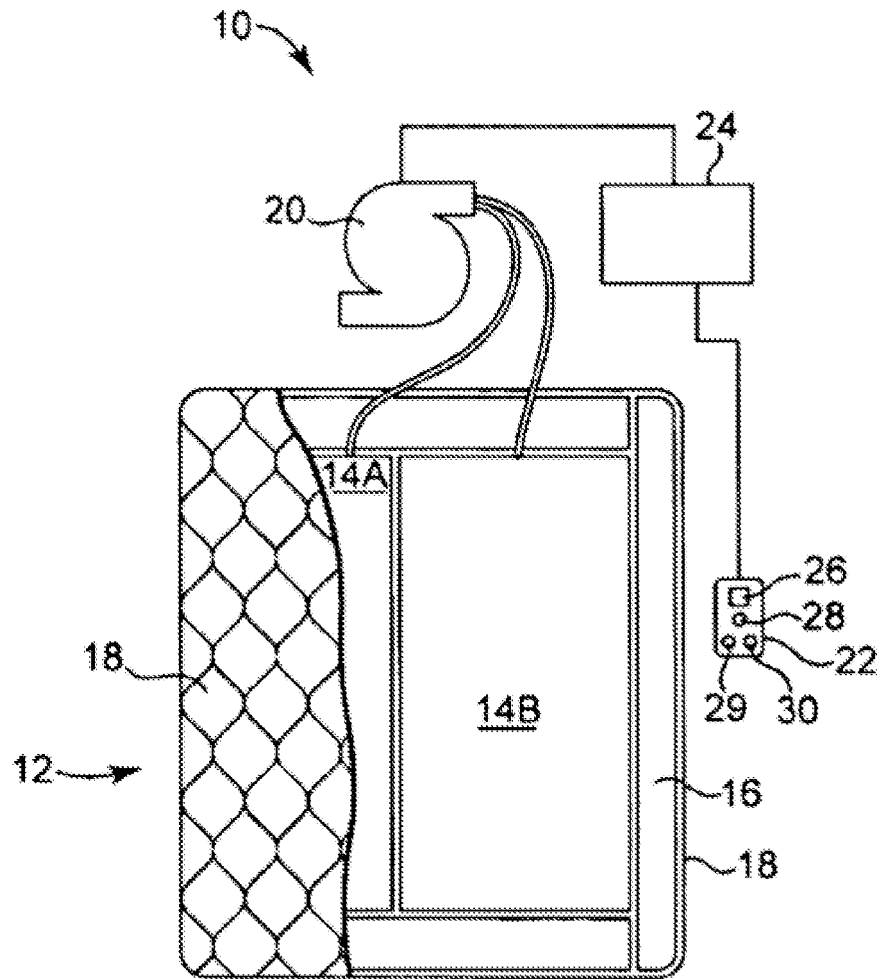

Fig. 1

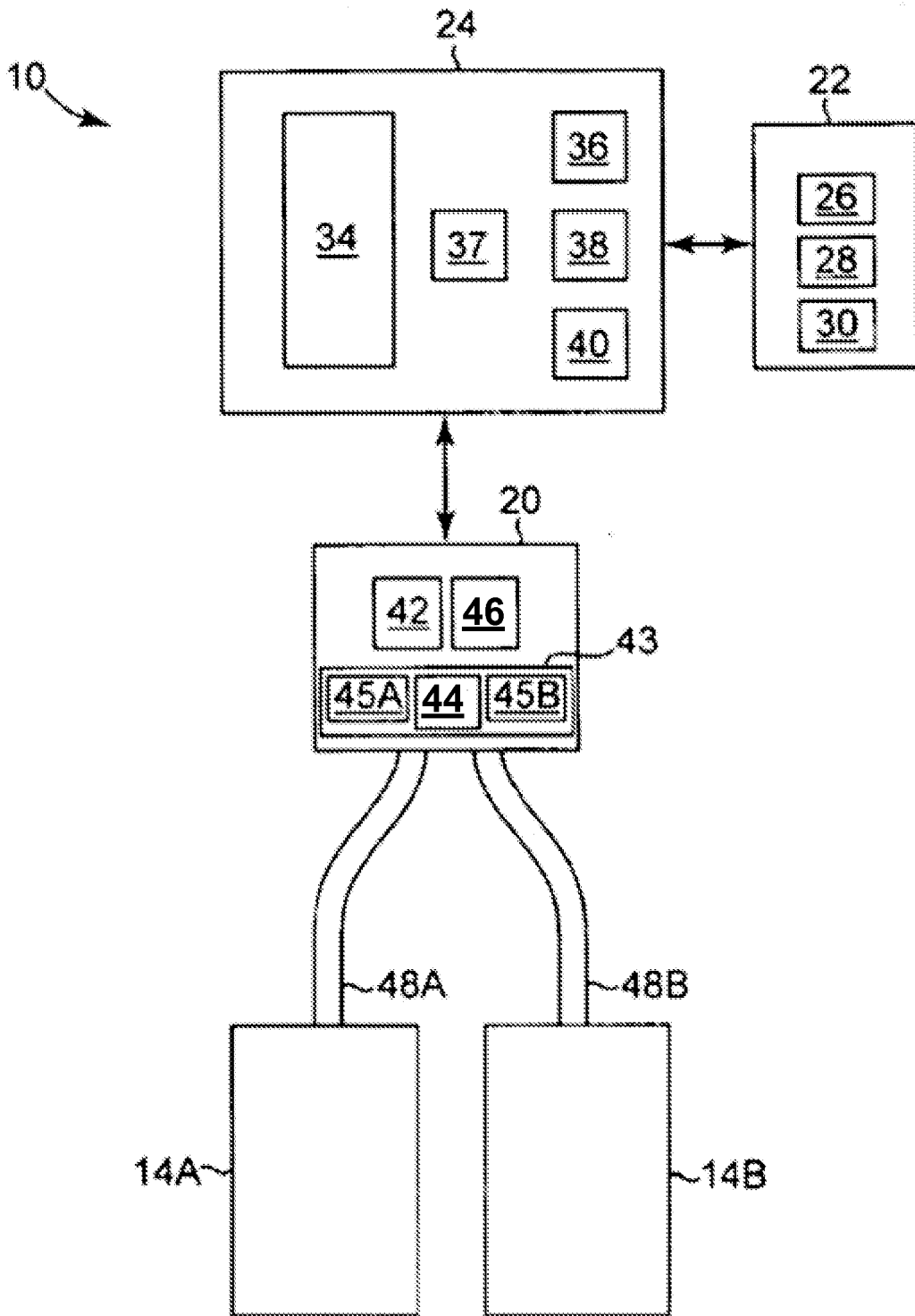
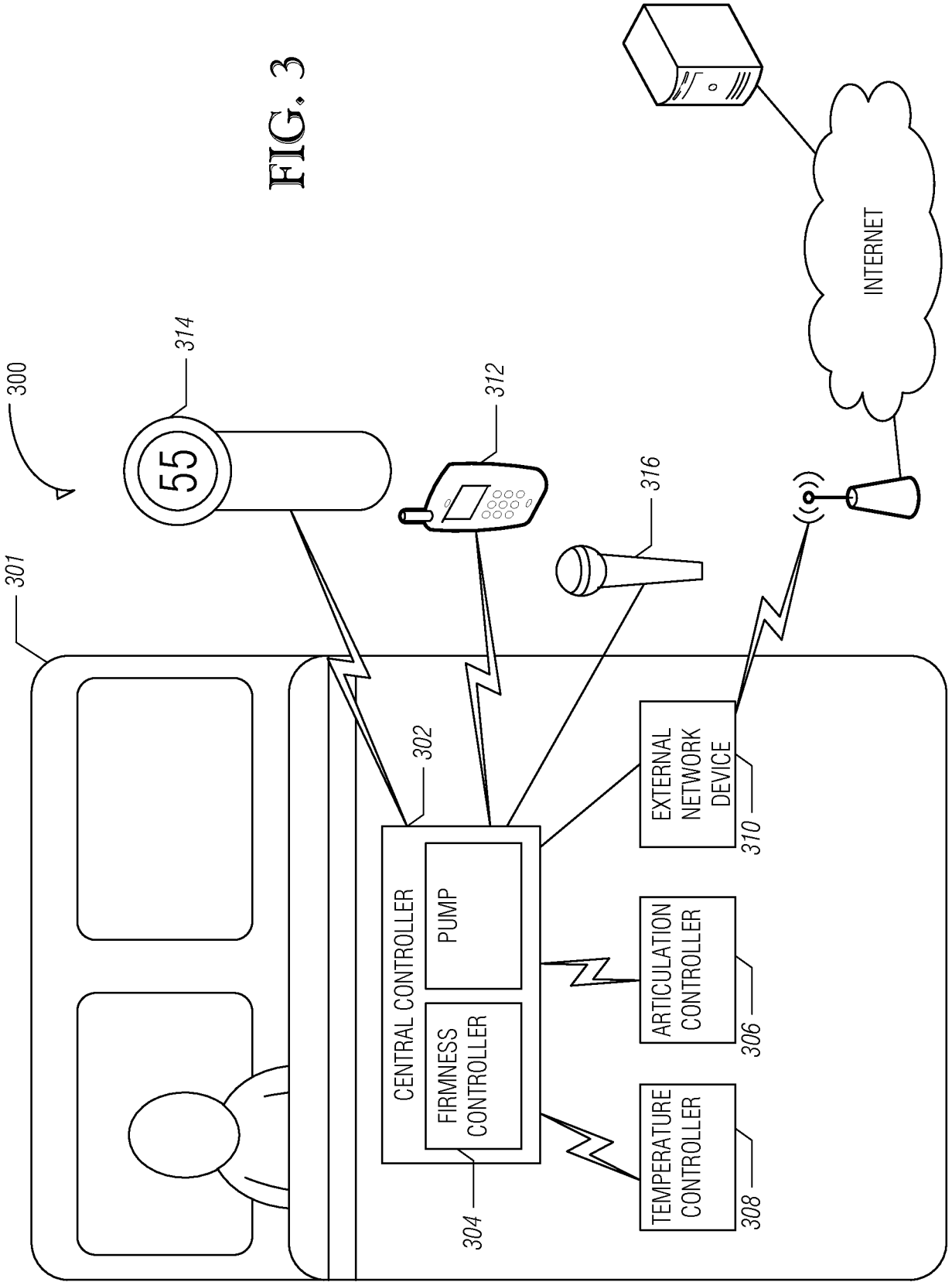

Fig. 2

FIG. 3



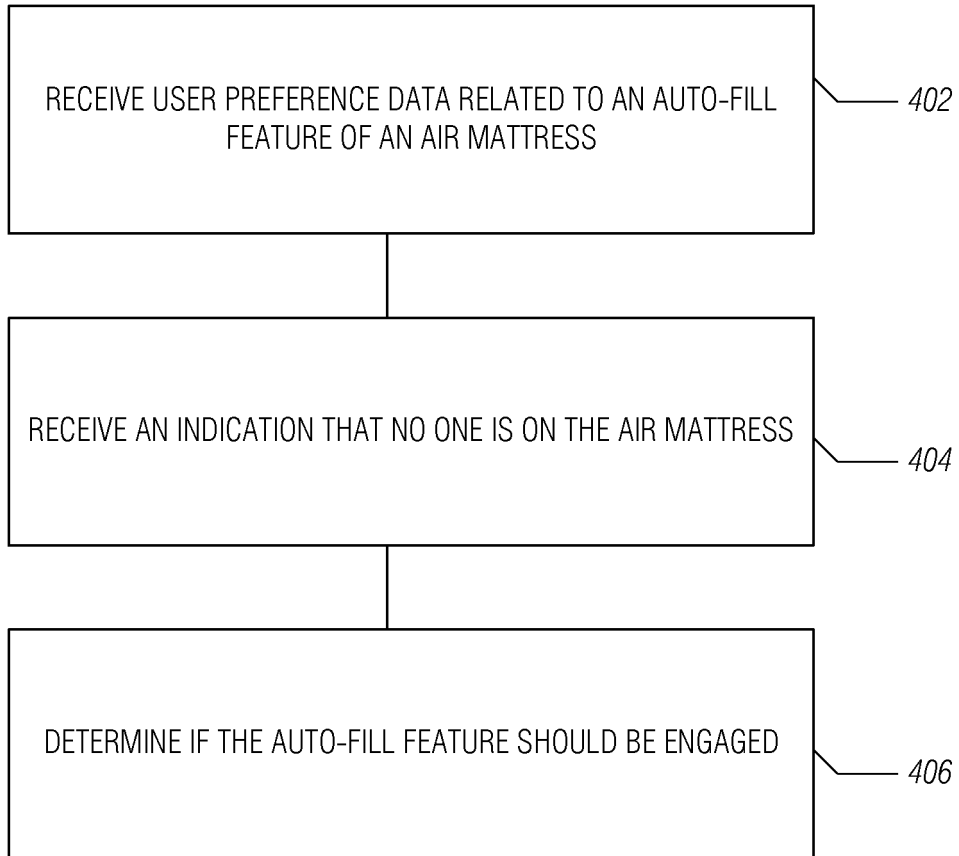

FIG. 4

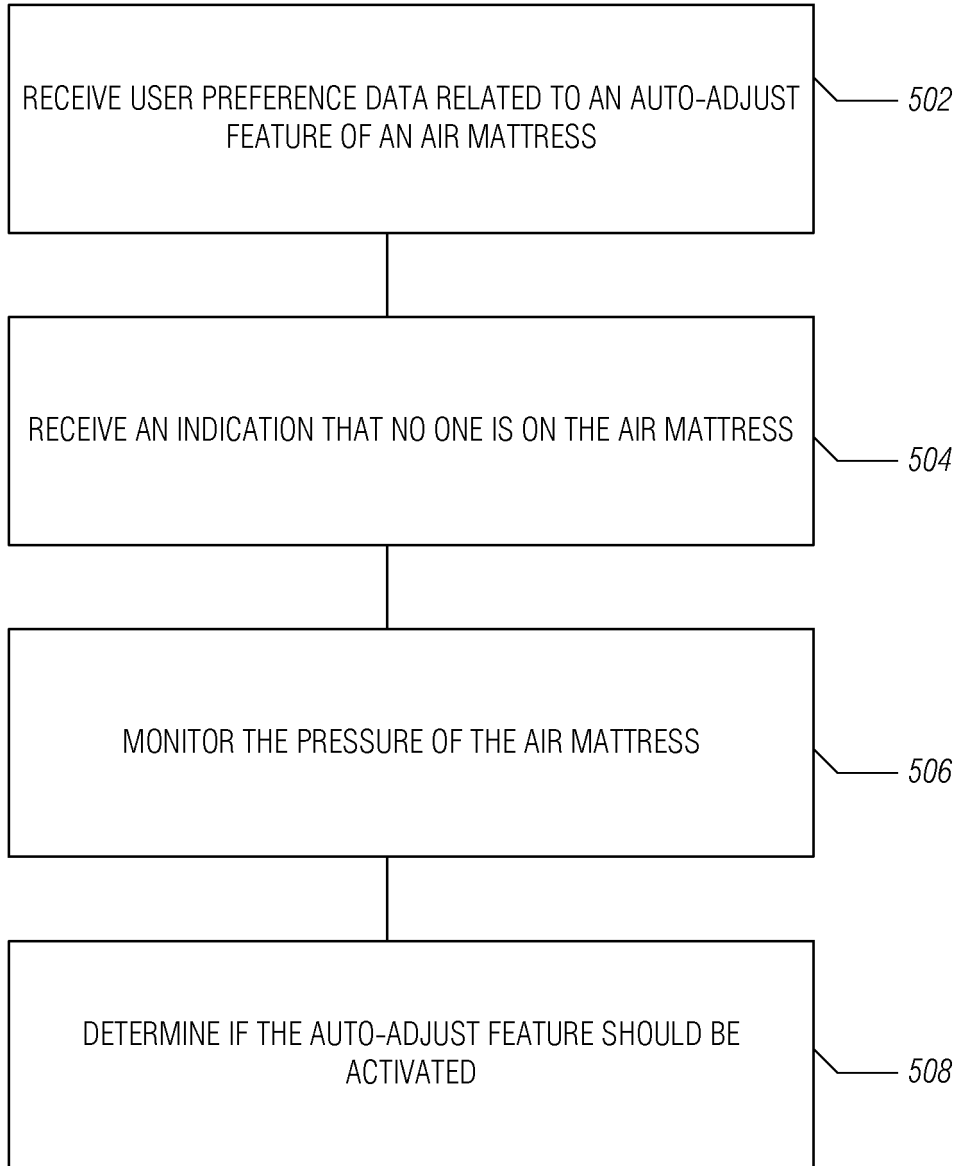

FIG. 5

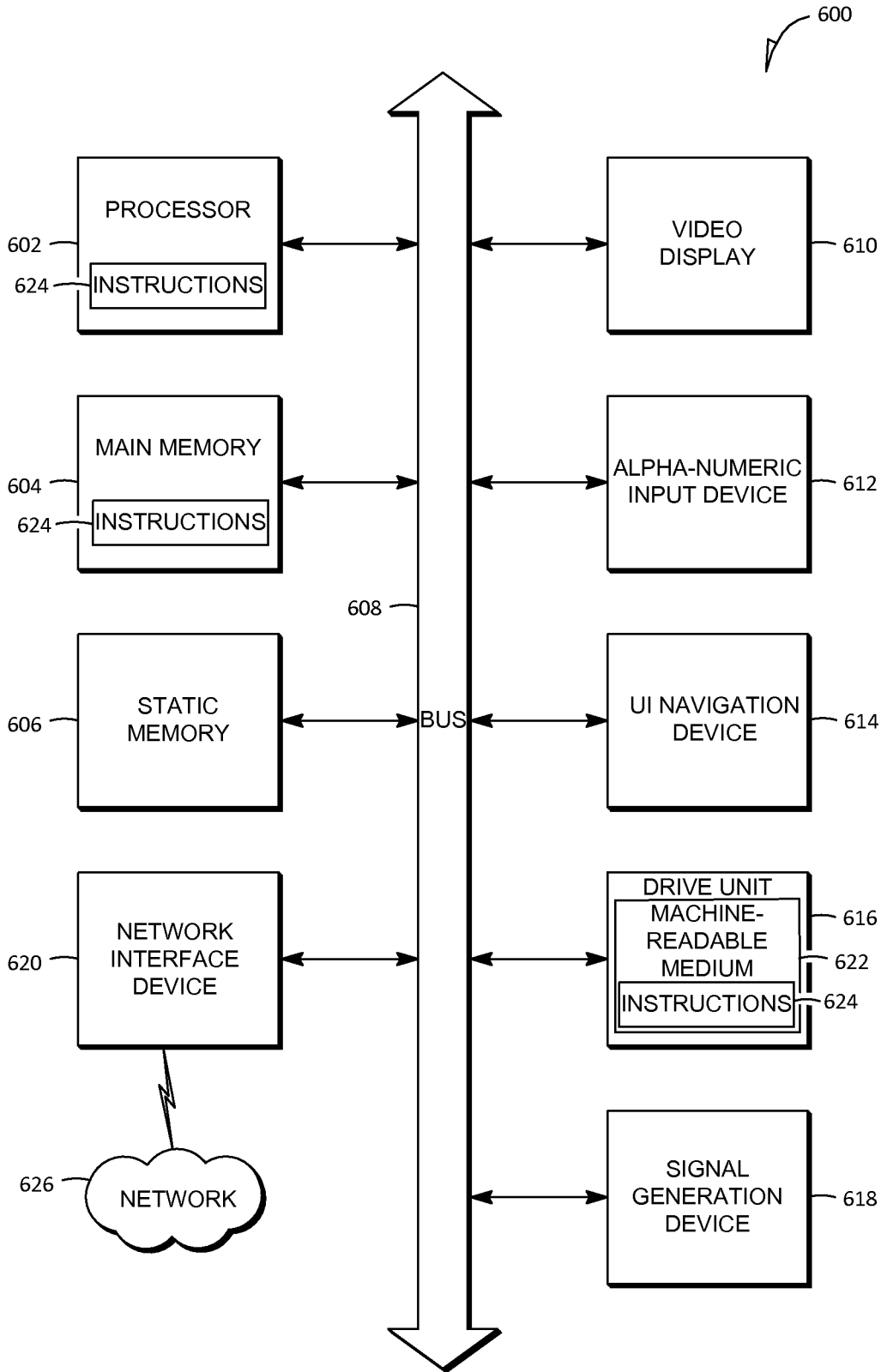

FIG. 6

REFERENCES CITED IN THE DESCRIPTION

This list of references cited by the applicant is for the reader's convenience only. It does not form part of the European patent document. Even though great care has been taken in compiling the references, errors or omissions cannot be excluded and the EPO disclaims all liability in this regard.

Patent documents cited in the description

- US 2012090698 A1 [0002]
- US 5948303 A [0002]
- EP 1884224 A2 [0002]
- US 936084 A [0015]

专利名称(译)	充气床垫自动填充和床外压力调节		
公开(公告)号	EP2967228B1	公开(公告)日	2018-03-07
申请号	EP2014720361	申请日	2014-03-13
[标]申请(专利权)人(译)	Select Comfort的 BAM LABS		
申请(专利权)人(译)	Select Comfort的CORPORATION BAM实验室, Inc.		
当前申请(专利权)人(译)	Select Comfort的CORPORATION SLEEPIQ LABS公司.		
[标]发明人	NUNN ROB PALASHEWSKI WADE DANIEL YOUNG STEVEN HEWITT CARL		
发明人	NUNN, ROB PALASHEWSKI, WADE DANIEL YOUNG, STEVEN HEWITT, CARL		
IPC分类号	A47C27/08 A47C31/12 A61B5/11 A61B5/00 A47C31/00 A61B5/08		
CPC分类号	A47C27/083 A47C21/04 A47C27/082 A47C27/084 A47C27/10 A47C31/00 A47C31/008 G05B19/0428		
代理机构(译)	康罗伊, JOHN		
优先权	61/781541 2013-03-14 US		
其他公开文献	EP2967228A1		
外部链接	Espacenet		

摘要(译)

一种方法和系统可以包括将信号传输到充气床垫的泵以将充气床垫的压力设定为初始压力;在中央控制器处接收用户偏好条件,用于自动调节充气床垫中的压力;在中央控制器处接收充气床垫空的指示;并且基于确定已满足用户偏好条件并接收该指示:检测充气床垫的压力变化超过阈值;并根据检测结果,将气垫的压力调节到初始压力。

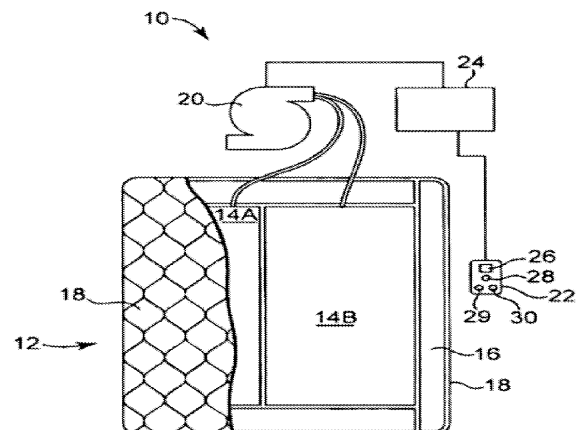

Fig. 1