

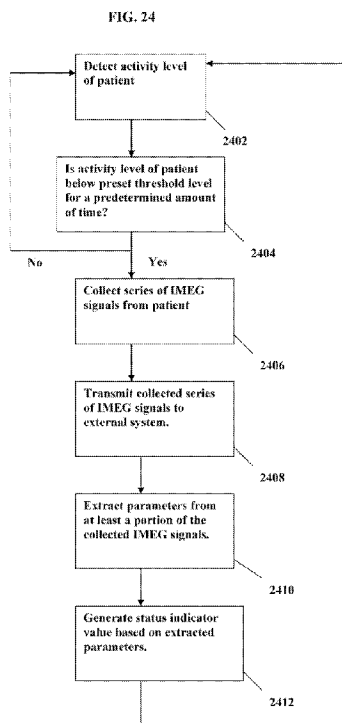

- (51) International Patent Classification: A61B 5/0402 (2006.01)
- (21) International Application Number: PCT/US2010/034121
- (22) International Filing Date: 7 May 2010 (07.05.2010)
- (25) Filing Language: English
- (26) Publication Language: English
- (30) Priority Data:
  - 61/215,956 13 May 2009 (13.05.2009) US
  - 61/240,576 8 September 2009 (08.09.2009) US
- (63) Related by continuation (CON) or continuation-in-part (CIP) to earlier application:
  - US 11/712,284 (CIP)
  - Filed on 27 February 2007 (27.02.2007)
- (71) Applicant (for all designated States except US): MONITORING INFORMATION TECHNOLOGIES, INC. [US/US]; 3113 Crest Lane, Fort Lee, NJ 07024 (US).
- (72) Inventor; and
- (75) Inventor/Applicant (for US only): SHOLDER, Jason [US/US]; 3113 Crest Lane, Fort Lee, NJ 07024 (US).
- (74) Agents: LEUNG, Richard, L. et al.; MORGAN, LEWIS & BOCKIUS LLP, 1701 Market Street, Philadelphia, PA 19103-2921 (US).
- (81) Designated States (unless otherwise indicated, for every kind of national protection available): AE, AG, AL, AM, AO, AT, AU, AZ, BA, BB, BG, BH, BR, BW, BY, BZ, CA, CH, CL, CN, CO, CR, CU, CZ, DE, DK, DM, DO, DZ, EC, EE, EG, ES, FI, GB, GD, GE, GH, GM, GT, HN, HR, HU, ID, IL, IN, IS, JP, KE, KG, KM, KN, KP, KR, KZ, LA, LC, LK, LR, LS, LT, LU, LY, MA, MD, ME, MG, MK, MN, MW, MX, MY, MZ, NA, NG, NI, NO, NZ, OM, PE, PG, PH, PL, PT, RO, RS, RU, SC, SD,

[Continued on next page]

(54) Title: SYSTEMS AND METHODS FOR HEART AND ACTIVITY MONITORING



(57) Abstract: Methods and systems for monitoring a heart failure or transplant rejection status of a patient including use of a device or system to collect intramyocardial electrogram (IMEG) signals from the patient at different times automatically when a detected activity level of the patient is below a preset threshold level for a predetermined amount of time, and use of a device or system to generate a status indicator value proportional to a combination of parameters extracted from at least a portion of the collected IMEG signals. Methods and systems can also include measuring time delay values between IMEG signals collected from different locations in the patient. The IMEG signals can be collected from the right ventricular septum and the right ventricular apex of the patient or from the right and left ventricular myocardium of the patient.

WO 2010/132311 A1



SE, SG, SK, SL, SM, ST, SV, SY, TH, TJ, TM, TN, TR, TT, TZ, UA, UG, US, UZ, VC, VN, ZA, ZM, ZW.

SM, TR), OAPI (BF, BJ, CF, CG, CI, CM, GA, GN, GQ, GW, ML, MR, NE, SN, TD, TG).

**(84) Designated States** (*unless otherwise indicated, for every kind of regional protection available*): ARIPO (BW, GH, GM, KE, LR, LS, MW, MZ, NA, SD, SL, SZ, TZ, UG, ZM, ZW), Eurasian (AM, AZ, BY, KG, KZ, MD, RU, TJ, TM), European (AL, AT, BE, BG, CH, CY, CZ, DE, DK, EE, ES, FI, FR, GB, GR, HR, HU, IE, IS, IT, LT, LU, LV, MC, MK, MT, NL, NO, PL, PT, RO, SE, SI, SK,

**Published:**

- *with international search report (Art. 21(3))*
- *before the expiration of the time limit for amending the claims and to be republished in the event of receipt of amendments (Rule 48.2(h))*

**SYSTEMS AND METHODS FOR HEART AND ACTIVITY MONITORING****CROSS-REFERENCE TO RELATED APPLICATIONS**

**[0001]** This application is a continuation-in-part of U.S. Patent Application No. 11/712,284, filed February 27, 2007, which claims the benefit of U.S. Provisional Patent Application No. 60/776,834, filed February 27, 2006, each of which are incorporated herein by reference in its entirety. This application also claims the benefit of U.S. Provisional Patent Application No. 61/215,956, filed May 13, 2009, and U.S. Provisional Patent Application No. 61/240,576, filed September 8, 2009, each of which is incorporated herein by reference in its entirety.

**TECHNICAL FIELD OF THE INVENTION**

**[0002]** The present invention relates, in some embodiments, to systems and methods for monitoring the heart of a patient. In some embodiments, the present invention relates to systems and methods for monitoring the activity of a patient. More particularly, the present invention relates, in some embodiments, to systems and methods for monitoring the heart failure status of a patient. In some embodiments, the present invention relates to systems and methods for monitoring for heart transplant rejection in a patient.

**INCORPORATION BY REFERENCE**

**[0003]** Each reference identified herein is hereby incorporated by reference as if set forth in its entirety.

**BACKGROUND OF THE INVENTION**

**[0004]** Thousands of people die each year because of heart related problems, including heart disease, heart attack (myocardial infarction), stroke, and heart failure. In many cases, significant heart problems may be corrected through medication, transplant, stenting, valve replacement, medical consultation, or other forms of medical intervention. Medical personnel need an effective method of monitoring the patient's heart for different symptoms, conditions, and parameters in order to provide effective treatment.

[0005] For the most part, heart monitoring requires that the patient visit the physician for an electrocardiogram (ECG) and/or other diagnostic tests. Frequently, the ECG by itself is only one of the many diagnostic tools that the physician has in his/her armamentarium, and not adequate alone to diagnose transplant rejection, heart failure, and other heart related disorders. When cardiac events occur infrequently (paroxysmal occurrences), ECG may not be effective in detecting certain heart events, such as arrhythmias, tachycardia (fast than normal heart rate), bradycardia (slower than normal heart rate), premature ventricular contractions (PVC), bigeminy, trigeminy, or other abnormal rhythms.

[0006] Current heart monitoring systems provide limited heart monitoring capabilities. Other systems are ineffective at detecting problems because of patient movement, respiration, inspiration, and emotional or physiologic stress. Frequently, traditional methods of heart monitoring are ineffective or incapable of detecting the subtle heart performance metrics that may indicate that heart failure or transplant rejection is present or imminent.

#### SUMMARY OF THE INVENTION

[0007] The present invention includes, in some embodiments, methods and systems for monitoring a heart failure status of a patient. In further embodiments, the present invention includes methods and systems for monitoring for heart transplant rejection in a patient.

[0008] A method according to some embodiments of the present invention includes detecting the activity level of the patient. In some embodiments, the activity level of the patient is detected using an accelerometer. In some embodiments, the accelerometer is a piezoelectric accelerometer. In some embodiments, the accelerometer is configured to detect motion of the patient. In some embodiments, a counter records the total number of times motion of the patient is detected by the accelerometer during each of a series of consecutive time intervals.

[0009] In some embodiments, a method according to the present invention includes collecting intramyocardial electrogram (IMEG) signals from the patient. In some embodiments, a method according to the present invention includes collecting IMEG signals from the patient at different times automatically when the detected activity level of the patient is below a preset threshold level for a predetermined amount of time (e.g., when the patient is asleep or substantially at rest). In some embodiments, a method according to the present invention includes collecting IMEG signals from

the patient at different times automatically only when the detected activity level of the patient is below a preset threshold level for a predetermined amount of time. In some embodiments, the detected activity level of the patient is below a preset threshold level only when the patient is asleep or substantially at rest. In some embodiments, the detected activity level of the patient is below a preset threshold level for a predetermined amount of time when the number recorded by the counter during each of a predetermined number of consecutive time intervals is below a preset value. In some embodiments, the preset value is determined based on the number recorded by the counter during time intervals when the patient is asleep or substantially at rest. In some embodiments, the IMEG signals are collected over a fixed programmable period of time.

[0010] In some embodiments, the collected IMEG signals include IMEG signals collected from one or more locations in the patient. In some embodiments, the collected IMEG signals include IMEG signals collected from the right ventricular myocardium and/or the left ventricular myocardium. In some embodiments, the collected IMEG signals include IMEG signals collected from the right ventricular septum of the patient. In some embodiments, the collected IMEG signals include IMEG signals collected from the right ventricular apex of the patient. In some embodiments, the collected IMEG signals include IMEG signals collected from both the right ventricular septum and the right ventricular apex of the patient. In some embodiments, a method according to the present invention includes measuring a time difference (e.g., time delay) between IMEG signals collected from one location of the patient (e.g., right ventricular septum) and IMEG signals collected from a second location of the patient (e.g., right ventricular apex).

[0011] In some embodiments, the IMEG signals are collected using a device implanted in the patient. In some embodiments, the IMEG signals are collected using a device external to the patient. In some embodiments, the IMEG signals are collected using one or more electrode leads coupled to the implanted device. In some embodiments, the collected IMEG signals are unipolar IMEG signals. In some embodiments, the IMEG signals are collected using one or more electrically active unipolar screw-in electrode leads. In some embodiments, the IMEG signals are collected using one or more unipolar screw-in electrode leads having electrically active screws positioned within the myocardium of the patient. In some embodiments, IMEG signals are collected using an electrically active unipolar screw-in electrode lead positioned within the muscle tissue of the right ventricular septum of the patient. In some embodiments, IMEG signals are collected using an electrically active unipolar screw-in electrode lead positioned within the muscle tissue of the right ventricular apex of

the patient. In some embodiments, IMEG signals are collected using an electrically active unipolar screw-in electrode lead positioned within the muscle tissue of the right ventricular myocardium and/or the left ventricular myocardium. In some embodiments, the electrode lead(s) includes the accelerometer used to detect the activity level of the patient.

[0012] In some embodiments of the present invention, the collected IMEG signals are filtered at a bandpass having an upper end of at least 200 Hz. In some embodiments of the present invention, the collected IMEG signals are filtered at a bandpass having an upper end of at least 300 Hz. In some embodiments of the present invention, the collected IMEG signals are filtered at a bandpass having an upper end of at least 1 kHz. In some embodiments of the present invention, the collected IMEG signals are filtered at a bandpass having a lower end of about 1 Hz to about 5 Hz. In some embodiments of the present invention, the collected IMEG signals are filtered at a bandpass having a lower end of about 2 Hz to about 3 Hz. In some embodiments of the present invention, the collected IMEG signals are filtered at a bandpass spanning from about 1 Hz to about 1 kHz. In some embodiments of the present invention, the collected IMEG signals are filtered at a bandpass spanning from about 2 Hz to about 2 kHz. In some embodiments of the present invention, the collected IMEG signals are filtered at a bandpass spanning from about 3 Hz to about 333 Hz. In some embodiments, the collected IMEG signals are filtered using an amplifier. In some embodiments of the present invention, the amplifier is a component of a device implanted in the patient.

[0013] In some embodiments, a method according to the present invention further includes generating one or more status indicator values. In some embodiments, the one or more status indicator values are generated by a device implanted in the patient. In some embodiments, the method includes using a system or device external to the patient to generate the one or more status indicator values. In some embodiments, the status indicator value is proportional (e.g., directly proportional) to the combination of two or more parameters extracted (e.g., derived, measured, calculated, etc.) from at least a portion of the collected IMEG signals. Example parameters, according to some embodiments, include amplitude, slew rate or slope ( $dV/dt$ ), and time duration values of the IMEG signals. In some embodiments, a parameter is an averaged value for a plurality of IMEG signals (e.g., an average amplitude or average slew rate of a series of IMEG signals). In some embodiments, an “average” or “averaged” value refers to the average of a plurality of averaged values (e.g., an average of the average amplitude or slew rate values of a plurality of series of IMEG

signals). A status indicator value, in some embodiments, is directly proportional to an amplitude value (e.g., an averaged IMEG amplitude) and a slew rate (e.g., an averaged IMEG slew rate) extracted from at least a portion of the collected IMEG signals. In some embodiments, a status indicator value is directly proportional to an amplitude value and a time duration value (e.g., an averaged IMEG time duration) extracted from at least a portion of the collected IMEG signals. In preferred embodiments, the at least a portion of the collected IMEG signals includes only normally conducted IMEG signals (e.g., produced by signal conduction which originates in the SA Node). In some embodiments, the at least a portion of the collected IMEG signals includes only IMEG signals which are each appropriately preceded by a P-wave (e.g. which have a P-IMEG interval that does not deviate more than about  $\pm 15\%$  from a baseline P-IMEG interval).

**[0014]** In one embodiment, a method of the present invention includes: detecting the activity level of the patient; using a device to collect intramyocardial electrogram (IMEG) signals from the patient at different times automatically when the detected activity level of the patient is below a preset threshold level for a predetermined amount of time; and using a system or device to generate a status indicator value directly proportional to a product of an average slew rate and an average amplitude of at least a portion of the collected IMEG signals. In one embodiment, the device used to collect IMEG signals from the patient is implanted in the patient. In one embodiment, the system or device used to generate the status indicator value is external to the patient. In one variation of this embodiment, the collected series of IMEG signals includes IMEG signals from the right ventricular septum of the patient. In another variation of this embodiment, the collected series of IMEG signals includes IMEG signals from the right ventricular apex of the patient. In another variation of this embodiment, the collected series of IMEG signals includes IMEG signals from both the right ventricular septum and the right ventricular apex of the patient. In yet another variation of this embodiment, the collected series of IMEG signals includes IMEG signals from the right ventricular myocardium and/or the left ventricular myocardium.

**[0015]** A method according to other embodiments of the present invention, includes: a) detecting the activity level of the patient; b) automatically collecting a series of intramyocardial electrogram (IMEG) signals from the patient if the detected activity level of the patient is below a preset threshold level for a predetermined amount of time; c) transmitting the collected series of IMEG signals to a system or device external to the patient; d) using the external system or device to extract a first parameter and a second parameter from at least a portion of the collected series of IMEG

signals; e) generating a status indicator value that is directly proportional to the product of the first parameter and the second parameter; f) repeating steps a) through e) at different times to generate a plurality of status indicator values from the patient; and g) analyzing the plurality of status indicator values to determine a change in the heart failure status of the patient. In one variation of this embodiment, the collected series of IMEG signals includes IMEG signals collected from the right ventricular septum of the patient. In another variation of this embodiment, the collected series of IMEG signals includes IMEG signals collected from the right ventricular apex of the patient. In yet another variation of this embodiment, the collected series of IMEG signals includes IMEG signals collected from both the right ventricular septum and the right ventricular apex of the patient. In yet another variation of this embodiment, the collected series of IMEG signals includes IMEG signals collected from the right ventricular myocardium and/or the left ventricular myocardium.

**[0016]** In one variation of this embodiment, step d) further includes extracting a third parameter from the at least a portion of the collected series of IMEG signals and step e) further includes generating a second status indicator value that is directly proportional to the product of the first parameter and the third parameter. In one embodiment, the first parameter is an amplitude value (e.g., average amplitude) of the IMEG signals, the second parameter is a slew rate value (e.g., average slew rate) of the IMEG signals, and the third parameter is time duration (e.g., average time duration) of the IMEG signals. In one embodiment, analyzing the plurality of status indicator values includes examining one or more trends in the plurality of status indicator values over time (e.g., increases, decreases, plateaus, etc.). In some embodiments, analysis of the status indicator values is performed by the external system.

**[0017]** A method according to other embodiments of the present invention includes detecting the activity level of the patient; using a device implanted in the patient to automatically collect a series of intramyocardial electrogram (IMEG) signals from the right ventricular septum and the right ventricular apex of the patient if the detected activity level of the patient is below a preset threshold level for a predetermined amount of time; and using a device external to the patient to measure time differences between the IMEG signals collected from the right ventricular septum of the patient and the IMEG signals collected from the right ventricular apex. A method according to a variation of this embodiment further includes analyzing changes in the measured time differences between the IMEG signals collected from the right ventricular septum of the patient and the IMEG signals collected from the right ventricular apex to determine a change in the heart failure status of the

patient. A method according to another variation of this embodiment uses IMEG signals collected from the right ventricular myocardium and the left ventricular myocardium.

**[0018]** A method according to yet another embodiment of the present invention includes: a) detecting an activity level of the patient; b) automatically collecting a series of intramyocardial electrogram (IMEG) signals from a right ventricular septum and a right ventricular apex of the patient if the detected activity level of the patient is below a preset threshold value for a predetermined amount of time; c) transmitting the collected series of IMEG signals to a system external to the patient; d) using the external system to measure a time delay value between IMEG signals from the right ventricular septum and IMEG signals from the right ventricular apex; e) repeating steps a) through d) at different times to measure a plurality of time delay values from the patient; and f) analyzing the plurality of time delay values to determine a change in the heart failure status of the patient. A method according to a variation of this embodiment uses IMEG signals collected from the right ventricular myocardium and the left ventricular myocardium.

**[0019]** The present invention also includes, in some embodiments, a system for monitoring the heart failure status of a patient, which, for example, can be used to practice the methods of the present invention. In some embodiments, a system according to the present invention includes an implantable system implantable into a patient, and an external system external to the patient. In some embodiments, the implantable system includes an implantable device configured to collect a series of intramyocardial electrogram signals from one or more locations from the patient. The implantable device, in some embodiments, is coupled to an activity sensor configured to detect an activity level of the patient. In one such embodiment, the activity sensor is an accelerometer, such as, for example, the accelerometer described in the methods discussed above. The implantable system, in some embodiments, also includes one or more electrode leads

**[0020]** A monitoring system according to some embodiments of the present invention includes: an activity sensor configured to detect an activity level of the patient; an implantable device coupled to the activity sensor and configured to automatically collect a series of intramyocardial electrogram (IMEG) signals from the patient if the activity level of the patient detected by the activity sensor is below a preset threshold level for a predetermined amount of time; a device external to the patient configured to receive the collected series of IMEG signals, extract a first parameter from at least a portion of the collected series of IMEG signals, extract a second parameter from the at least a portion

of the collected series of IMEG signals, and calculate a status indicator value that is directly proportional to the product of the first parameter and the second parameter. In one variation, the collected IMEG signals include IMEG signals collected from the right ventricular septum of the patient. In another variation, the collected IMEG signals include IMEG signals collected from the right ventricular apex of the patient. In another variation, the collected IMEG signals include IMEG signals collected from the right ventricular myocardium of the patient. In yet another variation, the collected IMEG signals include IMEG signals collected from the left ventricular myocardium of the patient.

#### BRIEF DESCRIPTION OF THE DRAWINGS

[0021] Reference is made to the accompanying drawings which show illustrative embodiments of the present invention and which should be read in connection with the description of the invention.

[0022] FIG. 1 is a perspective diagram of a health monitoring system in accordance with the illustrative embodiments of the present invention;

[0023] FIGS. 2A-C represent heart wave forms in accordance with the illustrative embodiments of the present invention;

[0024] FIG. 3 is a graph illustrating heart rejection in accordance with the illustrative embodiments of the present invention;

[0025] FIG. 4 is a block diagram of a monitor system in accordance with the illustrative embodiments of the present invention;

[0026] FIG. 5 is an alternative embodiment of a monitor system in accordance with the illustrative embodiments of the present invention;

[0027] FIG. 6 is an embodiment of an external monitor system in accordance with the illustrative embodiments of the present invention;

[0028] FIG. 7 is an example of a screw-in myocardial electrode lead in accordance with the illustrative embodiments of the present invention;

[0029] FIG. 8 is a sample of heart data in accordance with the illustrative embodiments of the present invention;

[0030] FIG. 9 is an illustrative graph of physical activity in accordance with the illustrative embodiments of the present invention;

[0031] FIG. 10 is an example of data recorded by a monitor in accordance with the illustrative embodiments of the present invention;

[0032] FIG. 11 is an example of data recorded by a monitor in accordance with the illustrative embodiments of the present invention;

[0033] FIG. 12 is an example of data recorded by a monitor in accordance with the illustrative embodiments of the present invention;

[0034] FIG. 13 is a graphical illustration of threshold levels in accordance with the illustrative embodiments of the present invention;

[0035] FIG. 14 is a graphical illustration of adjusted threshold levels in accordance with the illustrative embodiments of the present invention;

[0036] FIG. 15 is a flowchart for a process for inserting a heart monitoring device in accordance with the illustrative embodiments of the present invention;

[0037] FIG. 16 is a flowchart of a process for performing heart monitoring during sleep in accordance with the illustrative embodiments of the present invention;

[0038] FIG. 17 is a flowchart of a process for measuring activity levels in accordance with the illustrative embodiments of the present invention;

[0039] FIG. 18 is a flowchart of a process for detecting heart events in accordance with the illustrative embodiments of the present invention;

[0040] FIG. 19 is an example page for demographics in a graphical user interface in accordance with the illustrative embodiments of the present invention;

[0041] FIG. 20 is an example page for patient listing in a graphical user interface in accordance with the illustrative embodiments of the present invention;

[0042] FIG. 21 is an example page for a new patient enrollment in a graphical user interface in accordance with the illustrative embodiments of the present invention;

[0043] FIG. 22 is an example page for setting parameters in a graphical user interface in accordance with the illustrative embodiments of the present invention;

[0044] FIG. 23 is an example page for a recorded event in a graphical user interface in accordance with illustrative embodiments of the present invention;

[0045] FIG. 24 is a flowchart of a process of monitoring a patient in accordance with further embodiments of the present invention;

[0046] FIGs. 25A and 25B are graphs showing example data related to patient activity level detected in accordance with some embodiments of the present invention;

[0047] FIGs. 26A-26C show example placement of electrodes in accordance with some embodiments of the present invention;

[0048] FIGs. 27A and 27B show example electrodes which may be used in accordance with embodiments of the present invention;

[0049] FIG. 28 shows an example system in accordance with some embodiments of the present invention;

[0050] FIG. 29 shows an example IMEG signal collected in accordance with embodiments of the present invention;

[0051] FIGs. 30A and 30B show examples of sinus and non-sinus beats in accordance with embodiments of the present invention;

[0052] FIGs. 31A-31D show examples of collected data in accordance with embodiments of the present invention;

[0053] FIGs. 32A and 32B show examples of trend graphs produced in accordance with embodiments of the present invention;

[0054] FIG. 33 shows a representation of the time difference between IMEG signals in accordance with embodiments of the present invention;

[0055] FIG. 34 shows septal and apical IMEG signals collected over different days in accordance with embodiments of the present invention; and

[0056] FIG. 35A-38D show animal data collected in accordance with an example of the present invention.

#### DETAILED DESCRIPTION OF EMBODIMENTS OF THE INVENTION

[0057] FIG. 1 is a perspective diagram of a heart monitoring system in accordance with illustrative embodiments of the present invention. The heart monitoring system 100 of FIG. 1 includes various elements including a home 101, a patient 102, a monitor 104, a mobile receiver 106, a transceiver 108, a network 110, a clinic 112, a computer 114, and a printer 116.

[0058] The heart monitoring system 100 monitors the health of the patient 102. In particular, the heart monitoring system 100 may be used to monitor the overall physiological status of the patient 102. This includes, in some embodiments, the status of the patient's heart. For example, the patient 102 may have recently undergone a heart transplant surgery during which the monitor 104 was surgically implanted. As a result, the health monitoring system 100 is able to record heart data including potential symptoms of rejection. In other embodiments, monitoring system 100 is able to record heart data including data which can be used to monitor the heart failure status of patient 102 and/or detect a change in the heart failure status of patient 102.

[0059] The monitor 104 is surgically implanted in the patient 102 to record, analyze and store vital health information. The monitor 104 may be a physiologic status monitor without leads attached to the patient's heart or may include electrode leads attached to the patient's heart and is further described by FIGs. 4-8. The monitor 104 may function as an Implantable Rejection Assessment Monitor (IRAM) and/or an intramyocardial electrogram (IMEG) monitor. In one embodiment, the monitor 104 may record and store data when the patient 102 is sleeping, resting, or in bed at home 101. This allows the monitor 104 to take more effective measurements because the

patient 102 is not experiencing some of the electrocardiographic variations associated with emotional or physiological stress, and/or other stimulus of wakefulness that may affect effective heart measurements.

**[0060]** Data recorded, analyzed and stored by the monitor 104 may be wirelessly sent to the mobile receiver 106 or the transceiver 108. The health monitor system may include the mobile receiver 106, the transceiver 108, or both based on the needs of the patient 102. The monitor 104 may transmit the data using a low power radio frequency (RF) signal or other data signal for communicating the recorded data to the mobile receiver 106 or the transceiver 108. For example, the data signal may be a BLUETOOTH® or WIFI® signal or low-power equivalents. The monitor 104, mobile receiver 106, or transceiver 108 may format the data recorded by the monitor 104 for transmission or communication. For example, the transceiver 108 may format the data into packets for transmission across an Internet Protocol (IP) network. In other embodiments, the format may be any communication format suitable for transmitting and reassembling the data sent from the monitor. The monitor may transmit the data to the mobile receiver 106 and transceiver 108 using numerous communication schedules. In one embodiment, the monitor 104 transmits the data at a specified time each morning around the time the patient 102 is waking up from a nights sleep. In another embodiment, the monitor 104 transmits data to the mobile receiver 106 and transceiver 108.

**[0061]** In different embodiments, the monitor 104 may communicate unidirectionally or bidirectionally with the mobile receiver and transceiver 108. For example, the monitor 104 may receive a handshake or verification signal from the mobile receiver 106 or transceiver 108 indicating that data was successfully received during a transmission or that the data needs to be resent because an error, fault, or other problem occurred during transmission. Alternatively, the transceiver 108 may communicate with the monitor 104 to send control signals, update software or logic, or send other parameters for operational or administrative use by the monitor 104.

**[0062]** The mobile receiver 106 may be a battery powered wireless device for receiving data from the monitor 104 and then retransmitting the data to a specified interface. The mobile receiver 106 may be worn by the patient 102 or otherwise attached to the patient 102 or the patient's clothing. The mobile receiver 106 may use general packet radio service (GPRS), a global system for mobile (GSM) communication data transmission technique that transmits data in packets rather than using a

continuous channel. GPRS may allow the mobile receiver 106 to make efficient use of available radio spectrum.

**[0063]** In one embodiment, the mobile receiver 106 may transmit the data to the transceiver 108. In another embodiment, the mobile receiver 106 may transmit the data through a wireless interface to the network 110. The network 110 may communicate the data to the computer 114 for subsequent analysis by a doctor, technician, or medical specialist. The data may be stored in a database internal to the computer 114 or externally connected. The wireless interface may be a network server, website, or other interface that receives the data before communicating it to the computer 114.

**[0064]** The transceiver 108 may be a combination of hardware and software elements that receives data from the monitor 104. In one embodiment, the transceiver communicates unidirectionally. In other embodiments, the transceiver 108 may both send and receive data through the network 110. The transceiver 108 may incorporate communications hardware, such as a local area network card, modem, or other similar telemetry components for sending and receiving data through the network 110. The network 110 may be a private, public, hardwired, wireless, or virtual network or any combination thereof. The transceiver 108 may be connected to the network wirelessly or through a wired connection, such as a dial-up, cable, DSL, or other connection. A wireless connection may be WiFi, WiMAX, satellite, or other wireless or cellular technology. For example, transceiver 108 may be connected to a DSL line that communicates with the computer 114 through the network 110, wherein the network 110 is the Internet.

**[0065]** The computer 114 may be a computing device equipped to receive data from a network. The computer 114 may be a desktop computer, laptop, personal digital assistant (PDA), cellular phone, or other data processing system. The computer 114 may include software or hardware for reconstructing the data for display to a doctor or other user. The computer 114 may include a graphical user interface or web browsing application for accessing the data from the monitor 104. In one embodiment, the data from the monitor 104 may be stored in a web server that is part of the network 110. The computer 114 may use a communications line to access, download, archive, or otherwise use the data. For example, when the patient comes to the clinic 112 to visit with the doctor, the doctor may use the computer 114 to show the patient 102 heart and activity levels. Alternatively, the computer 114 may send data to the interconnected or wireless printer 116 to view a hard copy of the data, data graphs, or other information.

[0066] FIGs. 2A-C represent heart wave forms in accordance with the illustrative embodiments of the present invention. FIGs. 2A-C may be measured by a heart monitor, such as monitor 104 of FIG. 1. FIGs. 2A-C include waveforms 202, 204, and 206. The waveforms 202, 204 and 206 may be measured by one or more electrode leads attached to the heart. The electrode lead may be attached to the right and left ventricles of the heart in various positions. For example, the electrode leads may be mechanically attached to the surface of or penetrate into the myocardial muscle of the heart or they may be positioned inside (e.g., floating inside) the ventricle of the heart. In other embodiments, the electrodes are positioned on the outside of the heart. The waveforms 202, 204, and 206 represent the depolarization and repolarization of cells in the neuromuscular fibers that result in contractions of the heart. As a result, the waveforms 202, 204, and 206 represent the electrical activity of a cellular contraction and an action potential. This activity occurs because of the interaction of sodium and potassium within a membrane. Neuromuscular fibers both conduct electrical signals and are muscular fibers that contract.

[0067] In FIG. 2A the P wave 208 represents atrial electrical activity which causes the atrium of the heart to contract. The depolarization of the ventricle is the electrical signal that causes ventricular contraction as represented by the Q wave 210, R wave 212, and S wave 214. The T wave 216 represents the electrical repolarization of the ventricles.

[0068] In FIG. 2B waveform 204 shows the leading edge of a cellular action potential including the resting level 218, threshold 220, rising phase 222, peak 224, repolarization 226, and hyperpolarization 228. The rise time or derivative of the voltage ( $dV/dt$ ) of this leading edge changes when a transplanted heart experiences the onset of rejection when the amplitude may or may not change. Because these signals are in a higher frequency domain than that measured with a standard electrocardiographic recorder, approximately .05 to 150 Hz, it is imperative to have a wider upper frequency spectrum. The monitor amplifier used to view this signal should cover a frequency of 2-3 Hz at the low end to 250 to 300 Hz at the upper end. The resting level 218 is the fully repolarized level before any new contractions may occur. The threshold 220 is when the electrochemical reaction of sodium and potassium reaches a point at which cellular contraction is initiated. The rising phase 222 is particularly important because it is the measure of the change in voltage over time recorded by the monitor. The rising phase 222 may also be referred to as the rise time or slope. The monitor is able to measure the change in voltage during the rise time.

[0069] The rise time is the time that passes between the threshold 220 and the peak 224. For example, if  $dV/dt$  is changing from 10mv/1ms to 10mv/1.5ms, indicating a slower cellular signal propagation time, a heart transplant patient may be experiencing signs of rejection. In another example, when a patient's  $dV/dt$  decreases, the patient's heart may be showing signs of an upcoming cardiac event.

[0070] Hyperpolarization 228 is the voltage level below that of the resting potential. The measurement of hyperpolarization sometimes appears on a surface electrocardiogram as an elevation or depression of the voltage measured between the Q wave 210 and the T wave 216. Changes in this value may indicate cardiac ischemia or poor myocardial oxygenation.

[0071] Most heart monitors only measure the peak 224 associated with the amplitude. Heart monitors are unable to measure the slope of the waveform 204 with an ECG machine having a high end frequency of approximately 150 Hz because the frequency component of interest is above 200 Hz. The amplitude may change based on electrode position which may vary as the patient breaths and the heart contracts. However, the slope and rise time is relatively constant even when the amplitude changes.

[0072] In FIG. 2C waveform 206 represents multiple, repetitive waveforms similar to the single waveform 204, but as measured by an IRAM with a frequency response of 2-3 Hz at the low end to 250-300 Hz at the upper end.

[0073] FIG. 3 is a graph illustrating heart rejection in accordance with the illustrative embodiments of the present invention. Graph 300 shows various elements including IMEG amplitude and  $dV/dt$  302, rejection line 304, timeline 306, heartbeat waveform 308, and points 310 and 312. Graph 300 illustrates that even though the amplitude of the heartbeat waveform 308 as measured by an intramyocardial electrogram remains relatively consistent as shown by the heartbeat waveform, the patient begins to experience rejection at point 310. Therefore, measuring amplitude alone is not as effective as measuring both amplitude and slope in order to detect rejection.

[0074] A monitor, such as monitor 104 of FIG. 1, may be used to measure the change in voltage of the heartbeat waveform 308 over time or  $dV/dt$ . As described in FIGs. 2A-B, as the IMEG amplitude and  $dV/dt$  302 begin to decrease, the  $dV/dt$  of the heartbeat waveform 308 begins to decrease indicating that rejection or a significant cardiac event is likely to occur. Even though

amplitude of the heartbeat waveform 308 may not indicate rejection is likely, by measuring the change in voltage measured over time, a doctor may more effectively prescribe medications and take other actions to prevent rejection, illness, or death of the patient. By detecting symptoms of rejection early the monitor allows the doctor more flexibility in treating the patient and the doctor may not be required to use extreme levels of steroids, antibiotics, and other cardioactive pharmaceuticals that may not be best for the patient's overall well-being.

[0075] FIG. 4 is a block diagram of a monitor system in accordance with the illustrative embodiments of the present invention. The monitor system 400 includes various elements including a receiver 402, a heart monitor 404, electrode leads 406 and 408, and a heart 410. The receiver 402 is a particular implementation of the portable receiver 106 or the transceiver 110 of FIG.1. The heart monitor 404 and electrode leads 406 and 408 are particular implementations of the monitor 104 of FIG. 1. The elements of the heart monitor 404 may be discrete components or may be a single integrated circuit that may be programmed or otherwise configured with various hardware, software and firmware surgically implanted in situ.

[0076] The heart monitor 404 further includes a magnetic reed switch 412, telemetry circuitry 414, a thermistor 416, a memory 418, a processor 420, analog to digital converters (A/D) and peak detector 422, amplifiers (amp) 426, 428, 430, 432, and 434, and piezoelectric accelerometer 436. The electrode leads 406 and 408 further include piezoelectric accelerometers 438 and 440. The heart monitor 404 may be an internal heart monitor (IHM), implantable rejection assessment monitor (IRAM), an implantable heart failure monitor (IHFM), an implantable transient event recorder (ITER), or an external transient event recorder (ETER). In one embodiment, the electrode leads 406 and 408 may be connected to the heart 410 using the electrode leads 406 and 408. In other embodiments, external ECG electrodes are employed or the heart monitor 404 may not require electrodes to monitor the patient. Each embodiment may include one or more leads and the number of the amplifiers 426, 428, 430, and 432 may also vary based on whether the piezoelectric accelerometers are integrated as part of the electrode leads 406 and 408.

[0077] The receiver 402 may be an external telemetry device for wirelessly receiving data from the heart monitor 404. The receiver 402 may include memory, logic, processor, and other circuitry and software for receiving and processing data from the heart monitor 404. The receiver 402 may also send data to the heart monitor 404, including a handshake, software, programming, and

parameter updates as previously described. In one embodiment, the receiver 402 may include a series of colored lights or a screen for displaying text that may indicate whether data has been sent and received. The colored lights may also specify whether the patient needs to call the doctor based on the received data. For example, if everything is received and transmitted correctly a green light may be displayed. If a red light is displayed, the receiver 402 may indicate that the patient needs to call the doctor as soon as possible.

**[0078]** In one embodiment, the receiver may include memory and logic for determining whether the received data indicates rejection, a heart event, or other condition that warrants immediate action by the patient or the patient's doctor. For example, a text display may tell the patient to "take an extra dose of antibiotics, aspirin, and call your doctor".

**[0079]** The heart monitor 404 may be formed from a titanium enclosure. Titanium produces on its own, titanium oxide, which is body-compatible and is used in conventional cardiac pacemakers. The heart monitor 404 may also be plastic or a composite. All of the components within the heart monitor 404 are body compatible and are secured in place. The implantable heart monitor 404 is vacuum sealed and impervious to body fluids. The electrode leads 406 and 408 connect to the heart monitor 404 through a glass-to-metal feed-through, or some other acceptable feed-through that allows the electrode leads 406 and 408 to be connected to the internal electronics of the heart monitor 404.

**[0080]** The power source 424 may be a battery or other power device. In one embodiment, the power source 424 is a lithium iodine or lithium silver chromate battery because of the extremely long battery life. Alternatively, the power source 424 may be any other solid state power device based on the power requirements.

**[0081]** The processor 420 is a micro processing device or unit for performing calculations, analysis, and coordinating the operation and control of the heart monitor 404. The processor 420 may include logic for controlling the functions and monitoring capabilities of the IRAM 420. The thermistor 416 may be a thermometer or a variety of temperature sensitive semiconductor elements. The thermistor 416 allows the heart monitor 404 to determine the patient's temperature which may indicate whether there is any infection or whether symptoms are temperature related.

[0082] The memory 418 is a storage device for storing digital or analog data as measured by the electrodes 406 and 408. The memory 418 may be nonvolatile memory such as random access memory (RAM), flash memory, or a miniaturized hard drive. The A/D and peak detector 422 may be used to convert analog data measured from the heart 410 into digital signals for storage in the memory 418. The A/D and peak detector 422 may also be used to measure the peak amplitude of the heartbeat as recorded. The data may be converted from analog form to digital for ease of storage in the memory 418 or for easier or subsequent transmission to the receiver 402.

[0083] The electrode leads 406 and 408 may be attached in any number of locations within the heart. In particular, there are three main vascular beds in the heart 410. In some embodiments, the electrodes may be connected in two to four locations. By monitoring the heart in multiple sites, plus a reference point in the atrium of the heart 410, the monitor 400 may perform a more sensitive evaluation of the electrocardiographic changes in the signal amplitude and morphology or shape of the wave. The electrode leads 406 and 408 allow for a more accurate reading than an endomyocardial biopsy. In one example, the left lead, electrode lead 408, may be placed via the coronary sinus.

[0084] Various amplifiers 430, and 432 are required for the electrodes 406 and 408 of the heart monitor 404. Each amplifier may detect unipolar myocardial signals from the screw-in or transvenous electrode leads 406 and 408 placed in either the atrium or ventricle. The processor 420 may switch the amplifiers to sequentially record the signal amplitudes using the A/D and peak detector 422. The maximum and minimum amplitudes recorded in any given period of time, such as every four hours, eight hours, or twenty four hours are used to obtain an average amplitude value. The average amplitude may also be determined for each activity level.

[0085] The amplifiers 426, 428, 430, 432, and 434 are used for the heart monitor 404 and may have a band pass characteristic for the different signals that may be detected, monitored, recorded and stored. For example, an external transient event recorder (ETER) may have a band pass filter centered at approximately 28 Hz. This band pass is sensitive to varying cardiac rhythms as measured by the heart monitor 404. The narrow band pass filter reduces baseline drift as the patient moves.

[0086] If the monitor is monitoring an electrocardiogram signal (ECG), the center frequency may be approximately 80 Hz. This amplifier and filter is sensitive to baseline changes or drift due to motion and would require a correction algorithm be performed for the monitored signal by the

processor 420. For an IRAM monitor, the center frequency would be approximately 200 Hz which is required to detect the signals that have been identified to change during heart rejection.

[0087] The piezoelectric accelerometer 436 may be a three axis piezoelectric sensor that determines both the position and activity level of the patient at any given time. The piezoelectric accelerometer 436 determines the activity level of the patient by converting the motions of the patient into an electrical signal that may be filtered or amplified by the amplifier 434 to generate a signal that may be used by the processor 420 to determine the activity level for storage in the memory 418. The piezoelectric accelerometer 436 may be used to initiate the recording of data by the electrodes 406 and 408.

[0088] In another embodiment, the piezoelectric accelerometer 436 may be used as an acoustic microphone to listen for lung sounds. For example, the piezoelectric accelerometer 436 may be used to determine whether a patient has pulmonary edema, mitral stenosis, pulmonary congestion, pneumonia, or other lung problems. The previously described library may also include lung related sounds for determining whether the piezoelectric accelerometer 436 has determined a lung issue that may need to be reported to the doctor.

[0089] The piezoelectric accelerometers 438 and 440 may detect acceleration in one or more directions. In one embodiment, the piezoelectric accelerometers 438 and 440 may be unidirectional accelerometers for measuring the motion of the different parts of the heart 410. The piezoelectric accelerometers 438 and 440 are positioned within the electrode leads in order to best sense the motion of the heart 410. The piezoelectric accelerometers 438 and 440 may also be used to measure not only the occurrence of a heart contraction, but the force of the heart contractions as well.

[0090] The telemetry circuitry 414 is the circuitry used to wirelessly transmit data to the receiver 402. The telemetry circuitry 414 may use any number of wireless protocols to send the data to the receiver 402. Telemetry protocols may include any number of RF signals including Bluetooth, WiFi, a specialized medical signal, and other protocols using low power signals. The telemetry circuitry 414 may include a transmitter and in some cases a receiver for receiving verification that the recorded data has been received by the receiver 402. During the time that the telemetry circuitry transmits data to the receiver 402, the processor 420 may disable the amplifiers 426, 428, 430, 432, and 434 for a short period of time in order to conserve power and ensure that the data transmission does not interfere with the detection of cardiac signals. The telemetry circuitry 414 may terminate

sending or retrying to send data once a handshake or confirmation signal is received from the receiver 402.

[0091] In another embodiment, the telemetry circuitry 414 may use radio frequency identification (RFID). For example, the telemetry circuitry 414 may only be activated when in proximity to the receiver 402. The receiver 402 may temporarily power and receive data from the heart monitor 404 by transmitting a power signal similar to the use of RFID tags.

[0092] The magnetic reed switch 412 may be used to manually activate the heart monitor 404 to send the recorded data. The magnetic reed switch 412 may be activated by placing an activation magnet over the monitor. The magnetic reed switch 412 may be any variety of magnetically sensitive semiconductor elements. For example, if the patient has experienced a heart event, the patient may use a magnet to activate the magnetic reed switch 412 to send the recorded data from the telemetry circuitry 414 to the receiver 402.

[0093] FIG. 5 is an alternative embodiment of a monitor system in accordance with the illustrative embodiments of the present invention. Monitor 500 includes most of the elements described in FIG. 4 with a few exceptions. In monitor 500, the electrodes 406 and 408 do not include piezoelectric accelerometers and as a result there is no need for additional amplifiers. For example, the monitor 500 may be an internal transient event recorder (ITER) for recording heart events and subsequently notifying the doctor and/or patient through the receiver 402.

[0094] In monitor 500, the electrode lead 406 may be placed in the right atrial appendage for detecting near field P waves and far field R waves. Alternatively, the electrode lead 406 may be placed in the right atrial appendage for detecting P waves and the electrode lead 408 may be placed in the right ventricle for detecting R waves independently.

[0095] FIG. 6 is an embodiment of an external monitor system in accordance with the illustrative embodiments of the present invention. External monitor 600 may include many of the elements previously described for FIGs. 5 and 6. The external monitor 600 further includes GPRS circuitry 602, button 603, and electrocardiogram electrodes 604, 606, and 608. In addition, the health monitor system of FIG. 6 includes patient 610, GPRS server 612, and web interface 614. The external monitor 600 may be worn or attached to the patient 610 in any number of ways. For example, the external monitor 600 may be worn on the patient's belt for convenience and easy access.

[0096] The ECG electrodes 604, 606, and 608 are attached to the patient 610 in the traditional manner. In one embodiment, once a heart event or other important data is recorded by the external monitor, the GPRS circuitry 602 may automatically transmit the data to the GPRS server 612 using the GPRS protocol. The GPRS circuitry may include the software and hardware necessary to send and receive data using GPRS. The doctor, patient, or other user may be provided access to the web interface 614 to review the monitored heart data. The web interface 614 may require that the GPRS server 612 be provided a password, authentication, or other security element for ensuring that the patient's data is only accessible by authorized parties. In one embodiment, the GPRS server 612 may automatically send an alert, email, or other message to the doctor, patient, or other user indicating that the external monitor 600 has recorded and transmitted heart event data.

[0097] Alternatively, the patient, upon feeling a symptom believed to be heart related, may activate the button 603. Once asserted, the button 603 sends a transmit signal to the GPRS circuitry 602 that automatically transmits the heart event data recorded by the external monitor and corresponding ECG electrodes 604, 606, and 608 to the GPRS server 612 indicating that this transmitted data was associated with a symptom. The power source 424 of the external monitor 600 may be rechargeable so that the patient may easily charge the external monitor 600 at night or add new batteries as needed. For example, the patient 610 may place the external monitor 600 in a charging cradle at night for mobile use during the day, much like a cellular phone or, if separate rechargeable batteries are used, replace the batteries in the device with fully recharged batteries and place the depleted batteries into the battery charger.

[0098] FIG. 7 is an example of a screw-in myocardial electrode lead in accordance with the illustrative embodiments of the present invention. An electrode lead 700 includes various elements including a screw-in tip 702, a piezoelectric accelerometer 704, wires 706, 708, and an electrode 710. The electrode lead 700 is a particular implementation of the electrode leads 406 and 408 of FIG. 4. The heart monitor preferably includes two electrode leads with one of the leads placed such that both right ventricular contractions and right ventricular depolarization signals may be detected. The second lead is preferably positioned such that both left ventricular contractions and left ventricular depolarization signals may be detected. However, any number of lead configurations may be used that allow both electrical and mechanical signals to be effectively received for monitoring.

[0099] The screw-in tip 702 is used to connect the electrode lead 700 to the muscle of the heart. The screw-in tip 702 may be attached myocardially or transvenously. Transvenous leads are passed into the heart via a vein and the screw tip is deployed after venous insertion. The electrode lead 700 may have an active fixation tip, such as the screw-in tip 702 or may include a passive fixation tip when placed transvenously.

[00100] The piezoelectric accelerometer 704 may be used to measure movement of the heart or alternatively may be used to measure the force of the contraction. The piezoelectric accelerometer 704 may be a variety of different sizes, thicknesses, shapes and metalization options.

[00101] As mentioned, the piezoelectric accelerometer 704 may be used as a microphone using a technique of acoustic cardiology. With acoustic cardiology, timing events are monitored using heart sounds, such as valve closure, which are a second order effect of the ventricles contracting. By using a piezoelectric sensor in the electrode lead 700, the monitor may record the primary indicator of ventricular contraction for determining the condition, strength, and relative performance of the heart.

[00102] The piezoelectric accelerometer 704 is connected to the monitor on one end and the electrode through the wire 706. The electrode 710 acts as a reference point to the piezoelectric accelerometer 704 and makes contact with body tissue. The voltage and current measurements recorded by the piezoelectric accelerometer 704 are passed to the monitor through wire 706. The wires 706 and 708 may be any transmission medium able to conduct signals received from the screw-in tip 702 and piezoelectric accelerometer 704 to the body of the monitor. In one embodiment, the piezoelectric accelerometer 704 is connected to an amplifier, such as amplifier 426 of FIG. 4 which is referenced to the titanium enclosure that is in contact with subcutaneous body tissue. The right ventricular screw-in lead tip 702 is connected to the amplifier 430 by the wire 706. The wire 708 passes-through the electrode 710 without making contact. For example, the electrode 710 may include an insulated pass-through by which the wire 708 continues without making electrically contacting the electrode 710. Amplifier 430 of FIG. 4 is also referenced to the titanium enclosure that is in contact with subcutaneous body tissue.

[00103] Thus, both the piezoelectric accelerometer 704 and the screw-in electrode 702 are connected to amplifiers referenced to the patient's subcutaneous tissue for measurement of both the mechanical movement of the right ventricle and the electrical depolarization signal or IMEG. A

similar configuration for amplifiers 428 and 432 of FIG. 4 exists for the left ventricular electrode lead.

[00104] The use of electrode lead 700 is particularly useful for the monitor because of the ability to measure the contractile movement, contractile force, and timing of the contraction. The timing measurements are particularly useful when the two leads are attached to the left and right ventricle. The electrode lead 700 may also be used for cardiac pacing in the case where pacemaker functionality is integrated with the monitor.

[00105] FIG. 8 is a sample of heart data in accordance with the illustrative embodiments of the present invention. Table 800 includes various elements including an IRAM serial number 802, a patient number 804, a protocol 806, and a date 807. Various data may be recorded by electrode lead 1 808 and electrode lead 2 810. The data for electrode leads 1 and 2 808 and 810 includes a number of readings 812, IMEG amplitude 814, average IMEG average 816, IMEG amplitude 818, time 820,  $dV/dt$  822, and average  $dV/dt$  824.

[00106] Table 800 is an example and shows only two sets of monitored and recorded heartbeats for two, five minute intervals. The recorded data of table 800 may include any number of data sets. All or a portion of the data may be recorded and/or subsequently transmitted to the receiver. Also, the averages of all the averages may be made so that there is only one value for the average IMEG amplitude 816 and the average  $dV/dt$  824.

[00107] FIG. 9 is an illustrative graph of physical activity in accordance with the illustrative embodiments of the present invention. Graph 900 includes various sections including section 902 and section 904. The x-axis represents physical activity level 906 and the y-axis represents time 908 throughout the day. Section 902 indicates increased physical activity levels as sensed by piezoelectric accelerometers in a monitor, such as monitor 104 of FIG. 1.

[00108] Section 902 indicates increased physical activity levels when the patient is awake and performing various activities. For example, the patient may be walking and performing the activities of the day. Section 904 indicates decreased activity levels when the patient is sleeping or profoundly resting. The assessment of various activity levels is made by monitoring the acceleration change in the piezoelectric accelerometer per unit time or  $dA/dt$ .

[00109] The monitor may be set to monitor only and/or monitor and record physical activity using a looping method to record events when the patient is awake and asleep or either awake only or asleep only. During the activity levels shown in 902 the monitor is not recording samples as described.

[00110] Section 904 indicates decreased activity levels when the patient is sleeping or profoundly resting. Once the reduced activity levels of section 904 are detected, the signals from the piezoelectric accelerometer may activate the monitor to record heart data while the patient is sleeping and to suspend recording when activity levels indicate the patient is awake as shown by section 902. This is extremely beneficial when used to monitor transplant patients for rejection since only monitoring of IMEG and  $dV/dt$  data during sleep is useful in detecting rejection.

[00111] FIG. 10 is an example of data recorded by a monitor in accordance with the illustrative embodiments of the present invention. FIG. 10 includes graph 1002, graph 1004, and graph 1006. Graphs 1002, 1004, and 1006 illustrate activity data that may be collected for a patient that is experiencing improving health. Graphs 1002, 1004, and 1006 may be displayed to a patient, doctor, or other specialist or user for graphically representing the progress of the patient. The graphs 1002, 1004, and 1006 may be part of a graphical user interface of a computing device or may be displayed independently. The person viewing the graphs 1002, 1004, and 1006 may specify values, parameters, or conditions for displaying the data. For example, the data may be shown for each hour of each day or for every other day as selected by the user.

[00112] Graph 1002 includes data for activity energy. The activity may be monitored by a piezoelectric accelerometer, such as piezoelectric accelerometer 436 of FIG. 4. The activity data is recorded by a monitor, such as monitor 104 of FIG. 1. As shown, graph 1002 indicates that the activity energy of the patient has been steadily increasing over time which may indicate that the health of the patient is improving.

[00113] Graph 1004 includes data for energy duration. Energy duration may specify the amount of time the monitor records the patient performing activity above a specified threshold. For example, any recorded activity level that does not include sleeping may be displayed in the graph 1004. As a result, the graph 1004 may specify the amount of time a patient is awake and active for determining the energy level of the patient.

[00114] Graph 1006 includes data for combined sensor data. Graph 1006 may be a combination of data and factors. For example, graph 1006 may include the data measurements as shown in graph 1002 and 1004. As a result, a doctor may more easily evaluate the condition of the patient based on the activity levels performed by the patient and the amount of the time the patient spends performing that activity.

[00115] FIG. 11 is an example of data recorded by a monitor in accordance with the illustrative embodiments of the present invention. FIG. 11 includes graph 1102, graph 1104, and table 1106 similar to those of FIG. 10. Graphs 1102, 1104, and table 1106 illustrate activity data that may also be collected for a patient that is experiencing improving health.

[00116] The graph 1102 indicates the activity duration. Graph 1102 may indicate the amount of time the monitor records the patient active at one or more activity levels as measured per hour, day, week, month or year. For example, graph 1104 may display the amount of time the patient engages in significant activity each day. Graph 1104 may specify the energy duration for one or more activity levels as selected by the user.

[00117] The graph 1104 is an indirect assessment of physiological status. The indirect assessment of physiological status may include a number of values or factors. The graph 1104 may include data that is scaled, averaged, or otherwise mathematically manipulated to provide a graphical representation, such as a bar chart, of the overall health of the patient. For example, graph 1104 may include an average for all recorded activity levels and the duration the patient is active in that activity level as well as a factor for sleep.

[00118] Table 1106 may include any number of data values measured by the monitor. Table 1106 may show data as recorded for each day. Table 1106 may include data values for activity (reciprocal of sleep), the activity threshold or exercise level, and the activity duration or time of exercise. This data may be added to form a total that may be used for a doctor in measuring all activity parameters for a patient in order to obtain a more sensitive and specific evaluation of a patient's overall health status.

[00119] FIG. 12 is an example of data recorded by a monitor in accordance with the illustrative embodiments of the present invention. FIG. 12 includes graph 1202 and table 1204. 1202 may indicate the target or overall health level of the patient. Table 1204 illustrates data that may be

measured and recorded to generate graph 1202. Graph 1202 and table 1204 suggest that the patient's health status is deteriorating.

[00120] FIG. 13 is a graphical illustration of threshold levels in accordance with the illustrative embodiments of the present invention. The monitor previously described may be constantly monitoring and recording data or may only record data that is above or below a specified threshold. The threshold may be a specified activity level as measured by the monitor, piezoelectric accelerometers, or both. Graph 1300 illustrates various threshold levels including threshold A 1302, threshold B 1304, threshold C 1306, and threshold level D 1308. The thresholds level 1 1310, level 2 1312, level 3 1314, and level 4 1316 are represented by dotted lines as shown. The x-axis 1318 of the graph 1300 represents time and the y-axis 1320 of the graph represents piezoelectric accelerometer output. The piezoelectric accelerometer output may be measured by one or more piezoelectric accelerometers or a multi-axis accelerometer in the body of a heart monitor, such as monitor 104 of FIG. 1. The piezoelectric accelerometer output of the y-axis 1320 may be represented by a voltage that indicates the level of energy that the patient is imparting to his/her motions. The monitor may record the activities of the patient throughout the day and data corresponding to the activity level and duration of time the patient spent at that activity level.

[00121] Levels 1-4 1310, 1312, 1314, and 1316 represent the automatically self-adjusting settings for activity threshold. For example, when the patient is home after surgery and spends several days in bed recovering from an illness, surgery, etc., the auto-threshold level may decrease until the patient begins the recovery process.

[00122] FIG. 14 is a graphical illustration of threshold levels in accordance with the illustrative embodiments of the present invention. The Levels 1-4 1310, 1312, 1314, and 1316 have been auto-adjusted based on the recent activity of the patient recovering from an illness. As a result, the graph 1300 shows automatically self-adjusting threshold levels A-D 1302, 1304, 1306, and 1308 as the patient begins to improve and increases his/her activity level.

[00123] As shown in graph 300 of 13B, the Levels 1-4 1310, 1312, 1314, and 1316 have all automatically increased above the next threshold level. The adjustment shown in graph 300 illustrates the categorization of activity into different activity levels based on trends and patient history. In one embodiment, the auto-adjustment of the levels 1-4 1310, 1312, 1314, and 1316 may be performed by the monitor. The space, voltage or y-axis 1320 between levels 1-4 1310, 1312,

1314, and 1316 are not necessarily linear. Statistical analysis may be used to auto-set the different threshold levels A-D 1302, 1304, 1306, and 1308 in order to characterize different activity measurements into the corresponding levels 1-4 1310, 1312, 1314, and 1316. The Levels 1-4, 1310, 1312, 1314, and 1316 may also be auto-adjusted downward if the patient suffers a recovery relapse or other setback that affects the activity level measured by the monitor. For example, if the patient is recovering from an illness, the patient is less likely to spend time sleeping or resting when recovering is progressing as it should.

**[00124]** FIG. 15 is a flowchart for a process for inserting a heart monitoring device in accordance with the illustrative embodiments of the present invention. The process of FIG. 15 may be implemented for a transplant patient or other patient that needs physiological or heart monitoring. The process of FIG. 15 may be implemented by a surgeon, cardiologist or other medical technology specialist. The process of FIG. 15 allows an intramyocardial electrogram to be taken using myocardial leads or transvenous leads.

**[00125]** The process of FIG. 15 begins, after the patient is medically prepped and anesthetized, as with most surgical procedures, by attaching the leads to the patient's heart (step 1502). The electrodes or leads may be pacemaker style electrode leads or modified pacemaker style electrode leads containing piezoelectric sensors for measuring both the electrical and mechanical activity of the heart. In one embodiment, the leads may be myocardial screw-in leads typically used for pacemaker applications that are designed to screw into the myocardial wall of the heart much like a corkscrew. In another embodiment, the leads may be inserted transvenously. A transvenous lead would be passed through a vein to the right ventricle. An incision in the deltoid-pectoral groove in the upper left or right chest area may be used to find a vein in order to insert the transvenous lead rather than inserting the leads into the heart using a thoracotomy or other extremely invasive and dangerous procedure.

**[00126]** The transvenous lead may still have a screw tip, but the screw is retracted into the body of the lead. Once the lead is passed transvenously to the right ventricle, the back end of the lead connector may be rotated to deploy a corkscrew tip if the lead is an active fixation design or it may be a passive fixation element whereby the lead is wedged into the trabeculae carne. The two leads may be inserted into the right ventricle. One lead is inserted for contact to the right ventricular septum, which is the wall separating the right ventricle from the left ventricle. The right ventricular

septum is anatomically part of the left ventricle and sensing of its mechanical movement may be detectable with a piezoelectric equipped electrode lead. The other lead is inserted into the apex of the right ventricle or the right lateral wall for measuring the right ventricle.

[00127] Next, the surgeon attaches the leads to the implantable rejection assessment monitor (IRAM). The surgeon further surgically implants the IRAM (step 1506) with the process terminating thereafter. The IRAM may be securely implanted in a subcutaneous pocket of the abdomen or in the deltoid-pectoral area of the shoulder. The surgical procedure may be performed in a hospital catheterization laboratory or a special procedures room typically with the patient usually under local anesthetic.

[00128] FIG. 16 is a flowchart of a process for performing heart monitoring during sleep in accordance with some illustrative embodiments of the present invention. The process of FIG. 16 may be performed by the IRAM or heart/physiological status monitor referred to hereinafter as the monitor after having been surgically implanted.

[00129] The process begins with the monitor determining whether the patient is sleeping (step 1602). The determination of step 1602 is made in order to take readings and measurements of the heart. Ideally, the best time to take measurements for transplant rejection is during alpha sleep or the sleep before rapid eye movement (REM) sleep begins. During the first few hours of sleep, the user is most likely to have a steady heart rate, reduced emotional stress, and other factors that make measurements taken at that time the most accurate for determining heart and physiological status.

[00130] The process of FIG. 16 may continuously verify whether the patient is sleeping in order to ensure the uniformity of data. For example, if the monitor determines that the patient is not asleep in step 1602, the measurements of any data go on hold until the patient is asleep again. This provides uniform data that may be statistically analyzed over time. As a result, measurements of the heart are performed more reliably with greater effectiveness for a real world environment where the patient is sleeping and most comfortable.

[00131] The determination that the patient is asleep may be made in any number of ways and using a combination of information and data. In one embodiment, the monitor and specifically piezoelectric accelerometers within the monitor may determine the physical position of the patient. The patient is more likely to be sleeping when positioned horizontally or reclined. The monitor may

also use the heart rate of the patient to determine whether the patient is active or resting. For example, even though the patient is partially reclined in a reclining chair the patient may be watching an action movie that has stimulated emotional stress so that adrenaline causes his heart to pump faster than normal. Even though reclined, this is not an ideal time to take heart measurements. The monitor may also use previous patterns to use existing data and historic data to determine when the patient is sleeping. In yet another embodiment, the piezoelectric sensor within the monitor may be used to determine that the patient is sleeping by monitoring the activity variance or  $dA/dt$ , where  $dA/dt$  is a change in activity per unit time. Little or no activity variance is a good indicator that the patient is sleeping.

[00132] If the patient is not sleeping, step 1602 is repeated until the monitor determines that the patient is asleep. Once the patient is determined to be asleep in step 1602, the monitor measures the amplitude and  $dV/dt$  of the intramyocardial electrogram (IMEG) of the right ventricle and left ventricle for a predefined number of heartbeats at a specified time interval (step 1604). The measurements of the left and right ventricle for amplitude and  $dV/dt$  may be made individually or simultaneously. In one example, the monitor may have a predefined number of ten heartbeats to evaluate and a specified time interval to view ten heartbeats every five minutes. As a result, the monitor records ten heartbeats every five minutes for amplitude and  $dV/dt$  for each ventricle or lead. In some patients, the heart rate is naturally elevated because of transplant, drugs or other factors. Measurements for the predefined number of heartbeats may be measured much faster because of their naturally faster heart rate.

[00133] The monitor averages the peak amplitude and  $dV/dt$  of the IMEG for each measurement to calculate a measurement average of amplitude and  $dV/dt$  (step 1606). By taking a running average, the monitor is able to accurately monitor heart statistics while minimizing the values that must be stored in memory. As a result, the monitor may take a very large sample size each night or each time the patient sleeps for providing the patient's doctor important information regarding heart and physiological status.

[00134] The monitor determines whether the measurement threshold is met (step 1608). The measurement threshold is a specified number of measurements or samples. The measurement threshold may be set by default or may be communicated to the monitor by the patient's doctor based

on circumstances and need. For example, the measurement threshold may be thirty six samples for each ventricle and based on twelve measurements per hour for three hours.

[00135] If the measurement threshold is not met, the monitor determines whether the patient is sleeping (step 1602). If the monitor determines the measurement threshold is met in step 1608, the monitor averages the respective measurement averages for all measurement intervals to calculate an overall measurement average for both ventricles (step 1612). The overall average is a single number for amplitude and  $dV/dt$  for each ventricle. In another embodiment, the overall average of step 1612 may be a single number for the entire heart for amplitude and  $dV/dt$ .

[00136] Next, the monitor transmits the overall average for amplitude and  $dV/dt$  for each ventricle and a representative sample rhythm IMEG or electrocardiogram (ECG) strip to a receiver (step 1614) with the process terminating thereafter. The data may be transmitted in a number of different ways. In one embodiment, the data may be transmitted at a predetermined time, such as 7:00 a.m. every morning. In another embodiment, the overall averages may be transmitted to the receiver at any time the monitor detects the presence of the receiver for transmission. In yet another embodiment, the overall averages may be transmitted to the receiver when the patient awakes from sleep evidenced by an increase in the monitored activity variance,  $dA/dt$ . The receiver may be a unit that is connected to a communications line, such as an Internet connection or a modem for sending data to a data processing system, server, or other computing platform for access by the doctor. In another embodiment, the patient may wear the receiver on a belt or harness and may use wireless technology, such as general packet radio service (GPRS) to transmit the data to a data processing system, server, or other computing platform for access by the doctor. The receiver may also be a specially programmed cellular phone designated to send and receive data from the monitor.

[00137] The representative sample is one entire sample measurement that is recorded by the monitor. The representative sample illustrates the entire heartbeat wave form for analysis and understanding of the condition of the patient's heart. For example, the representative sample may show a ten beat pattern for both the left and right ventricle. The representative sample transmitted during step 1614 allows a doctor or other specialist to see what is happening with the heart in order to perform other analysis or determinations. The representative sample also indicates the quality of the signal being received by the monitor ensuring that the monitor is working properly and that the electrodes are still properly connected.

[00138] The monitor may also be configured to continuously watch for a heart event, such as arrhythmia, trigeminy, bradycardia, tachycardia, and premature ventricular contractions (PVC). When an event is detected, the monitor may immediately transmit the information to the receiver for transmission and subsequent analysis by the doctor. The monitor may also transmit based on a predefined time period or other preferences.

[00139] FIG. 17 is a flowchart of a process for measuring activity levels in accordance with the illustrative embodiments of the present invention. The process of FIG. 17 may be implemented by a heart monitor or physiological status monitor. The process of FIG. 17 begins by starting a timer (step 1702). The timer ensures that the monitor transmits information or a status report once a day regardless of the sleeping activity of the patient.

[00140] The monitor then determines an activity threshold (step 1704). The activity threshold may be determined using various information and factors. The activity threshold may indicate the current activity level of the patient. The activity level indicates the amount of energy detected by the piezoelectric sensors in the monitor imparted by the patient's movements. In one embodiment, the activity level is determined by a piezoelectric accelerometer within the monitor that specifies the level of movements being performed. The thresholds are based on the output of the accelerometer which may be a voltage, other digital signal, or analog signal. There may be any number of activity thresholds, tiers, or ranges that indicate a specified activity level.

[00141] In one embodiment, there are four thresholds, any activity less than the first threshold indicates that the patient is asleep. Activity above the first threshold, but below the second threshold, indicates the patient is performing moderate movement. Activity above the second threshold, but below the third threshold, indicates that the patient is performing significant movement. Activity above the third threshold, but below the fourth threshold, indicates that the patient is performing vigorous movement. All activity for the patient throughout the day may be categorized into one of the threshold levels. The activity thresholds specify a categorization for each activity level. In another example, the activity level may be determined based on the heart rate of the patient and the activity as determined by the piezoelectric accelerometer.

[00142] The monitor determines whether to adjust the activity thresholds (step 1706). The determination to adjust the activity threshold may be made on past data trends or based on new activity levels. For example, if the patient has recently been performing vigorous movement, the

threshold level may be higher than if the patient was relatively sedentary. Some patients may never reach the point of performing vigorous movement. As a result, the threshold levels are automatically set and modified based on the measured activity of the patient. The determination of step 1706 may be made by a processor, logic, memory, and piezoelectric sensors within the monitor. The initial threshold ranges or values may be set arbitrarily or based on values determined for previous patients with similar circumstances.

**[00143]** If the monitor determines to adjust the activity threshold, then the monitor adjusts the activity thresholds based on the activity level (step 1708). Different patients may have different threshold levels. For example, many patients are naturally very active and may have higher threshold levels whereas other users are by nature much more sedentary or inactive. In another example, the active patient may get very sick or undergo a transplant necessitating an adjustment of the activity thresholds as the patient recovers and slowly returns to a more active lifestyle. The activity threshold is auto-set by the monitor based on actual patient activity measured by the monitor as objectively measured by one or more piezoelectric accelerometers. Next, the monitor determines the activity threshold (step 1704).

**[00144]** If the monitor determines not to adjust the activity threshold in step 1706, then the monitor determines whether the threshold level is one or below or two or above (step 1710). If the threshold is at one, the monitor measures and stores the sleep time and temperature (step 1712).

**[00145]** If the monitor determines the threshold is two or above, the monitor measures and stores a recording of time awake, activity amplitude, activity duration, and temperature (step 1714). By measuring and storing activity level measurements it is easy to see whether a patient is improving, getting worse, or stable with regard to physical activity. As a result, a doctor may objectively categorize a person's health based on activity. The data stored by the monitor is particularly suitable for graphing activity levels over time. The time awake indicates whether the patient is sleeping enough and active during the day. The activity amplitude and duration indicate what activity level is being reached and for how long.

**[00146]** After steps 1712 and 1714, the monitor determines whether to transmit data (step 1716). In one embodiment, the monitor may not transmit the data until the timer has reached a specified value or range. The determination may be made based on availability of the receiver, amount of stored

information, or other factors. If the monitor determines not to transmit data in step 1716, the monitor determines the activity threshold (step 1704).

**[00147]** If the monitor determines to transmit data in step 1716, the monitor transmits measurements to a receiver (step 1718). The receiver may be a hardwired unit that is connected to a communication line. Alternatively, the receiver may be worn by the patient and may use wireless technology to broadcast the recorded data to a specified device, interface, pod, server, or recipient. Next, the monitor may determine whether there is a handshake (step 1720). The handshake indicates whether the information was properly received. For example, the handshake may be received from a transceiver if the data transmitted from the monitor is received without errors. The handshake may be a confirmation or other signal indicating the data has been successfully received. If there is not a handshake, the monitor may wait for a period of time (step 1720) and determines whether to transmit the data (step 1716).

**[00148]** If the monitor determines there is handshake in step 1720, the monitor may clear the memory and resets the timer (step 1724). The memory may be cleared to make space for new data. The reset timer may indicate that data has been transmitted for that day or other specified time period and is reset to begin again. The monitor starts the timer (step 1702). The process of FIG. 17 is repeated continuously to monitor the status of the patient. As a result, doctors or other medical personnel may use the data measured and stored in steps 1712 and 1714 to determine the type of activity the patient is engaging in and how often the activity level is performed. The doctor may use previously recorded data to view changes in the patient's activity that are a direct byproduct of health and well-being. For example, during a patient/doctor visit, the doctor may say "let's pull up your data from last month and see how you are doing." The doctor may recommend new activities, drugs, or perform additional analysis based on information from the patient and the recorded data. For example, the patient may imply that he has been exercising, but the monitor may give a more realistic or accurate report of activity levels. The recorded data transmitted to the doctor provides an indirect measurement of cardiac performance, neurological, and physiological performance. The monitor is useful for patients that experience inactivity, over activity, or other combinations of activity problems.

**[00149]** FIG. 18 is a flowchart of a process for detecting heart events in accordance with the illustrative embodiments of the present invention. The process of FIG. 18 may be implemented by a

heart monitor or physiological status monitor. The process begins with the monitor determining whether a heart event is detected (step 1802). The heart event may be bigeminy, trigeminy, bradycardias (slow heart rates), tachycardias (fast heart rates), premature ventricular contractions (PVC), multiple PVCs, any kind of arrhythmia or other heartbeat abnormality. The heart event may be detected in step 1802 by monitor logic. For example, the monitor logic may compare the patient's normal heartbeat morphology (wave shape) that has been previously recorded and stored, in either analog or digital format, with the current heartbeat to determine if there is an irregularity. If a heart event is not detected, the monitor continues to repeat step 1802 until a heart event occurs.

**[00150]** If a heart event is detected in step 1802, the monitor may record and store the heart event in event data (step 1804). In one embodiment, the monitor is continuously recording waveforms recorded received from the electrode leads. However, once an event is detected in step 1802, a specified time period before, during, and after the heart event may be recorded. For example, the monitor may store the heart event data as well as thirty seconds before and after the event. The pre-event time frame and post event time frame may be set by default or may be programmed based on the needs and condition of the patient. The sample or recorded data may be stored in analog or digital form. For example, the monitor may use analog to digital converters to convert the representative heartbeats or waveforms into digital data.

**[00151]** Next, the monitor compares the heart event with a database (step 1806). The database may be a program or memory that stores a library of heart events for comparison. The database may be a portion of the memory that specifies the signature, characteristics or parameter of each possible type of heart event. In one embodiment, if the patient has already experienced a confirmed heart event the current event may be compared with the stored event. The recorded heart event may be recorded in digital or analog form based on accuracy of comparison. The database may include a library of heart events that may be compared against the heart event detected in step 1802. In one embodiment, the monitor logic may specify the severity of the event, if known, for reference by a doctor.

**[00152]** The monitor determines whether the heart event is known (step 1808). If the heart event is known, the monitor inserts a heart event categorization in the event data (step 1810). For example, the monitor may insert a header or label that specifies that the recorded heart event is a tachycardia PVC. The data inserted in step 1810, may be useful to a doctor or other medical specialist that may respond to the patient's heart event.

**[00153]** After step 1808 or 1810, the monitor determines whether transmission is possible (step 1812). The monitor may include transmission logic for specifying when and how data is sent from the monitor. In one embodiment, a detected heart event is to be sent immediately once received. As a result, the monitor may need to determine in step 1812, whether a mobile receiver or other transceiver is available. For example, the monitor may detect a status or availability signal when in proximity to a receiving device that indicates that the monitor may transmit the event data. In another embodiment, the transmission logic may specify that heart events are only to be sent at a specified time period. Alternatively, the patient may wear a portable receiver that is used to send the event data using GPRS as soon as received.

**[00154]** If the monitor determines transmission is possible, the monitor transmits the event data to a receiver (step 1814) with the process terminating thereafter. As previously discussed, the event data may be sent to a receiver that retransmits the event data to the doctor. The event data may also be sent directly to the doctor, to a web interface, a server, or other receiving device. As part of step 1814, the monitor may require that a handshake or data receipt confirmation is received. For example, as part of step 1814 once a receipt handshake has been received from the receiver or transceiver, the monitor may delete the event data to make space available for other heart events and other recorded data.

**[00155]** If the monitor determines transmission is not possible in step 1812, the monitor may wait for a time period (step 1816) and then again determine whether transmission is possible (step 1812). The event data is maintained until it may be transmitted to a receiver in step 1814. In some cases, the monitor may record multiple heart events before the data may be transmitted because transmission is not possible.

**[00156]** FIGs. 19-23 illustrate examples of pages that may be displayed in a graphical user interface accessible by the patient, doctor or other authorized individual. The graphical user interface may be displayed to the user through the Internet using a web browser, program application, or database executed on one or more computing devices, such as a personal computer or PDA. The examples shown include pages and fields for doctor's demographics, patient listing, new patient enrollment, set parameters, billing, heart data, activity and event data, and samples of recorded events.

**[00157]** FIG. 19 is an example page for demographics in a graphical user interface in accordance with the illustrative embodiments of the present invention. Page 1900 includes various information,

sections, or details that may be used to identify the doctor or other user accessing the page 1900 of the graphical user interface. The page 1900 may include section 1902, section 1904, section 1906, and section 1908.

**[00158]** Section 1902 may include data for identifying the physician which may include a practice name, one or more physician names, and a Unique Physician Identification Number (UPIN) number of each physician.

**[00159]** Section 1904 may specify the address of each doctor including address, telephone number, and other contact information. This may allow the doctor to be contacted in the event a heart event is detected or one physician needs to contact another. Section 1906 may include authorization information for accessing the graphical user interface, page 1900, and other patient information. Section 1908 may include special instructions regarding the doctor or other notices that may be helpful.

**[00160]** FIG. 20 is an example page for patient listing in a graphical user interface in accordance with the illustrative embodiments of the present invention. Page 2000 may include data for any number of patients. Page 2000 may be particularly useful for tracking numerous patients that are using a monitor. Section 2000 may include various information regarding patients which may include a patient name and number assignment, address, phone, device model and serial number for the monitor, and information for setting parameters. The patient number and device model and serial number may be part of the data that is sent and received from the monitor in order to ensure that the recorded data is properly routed to individuals authorized to see the patient's data.

**[00161]** FIG. 21 is an example page for a new patient enrollment in a graphical user interface in accordance with the illustrative embodiments of the present invention. Page 2100 may be used to enroll a new patient. For example, a patient that has recently had a heart monitor surgically implanted may have his/her patient information entered into page 2100. The information may specify the patient's name, address, contact information, device model, serial number, and patient number, a referring physician, and next of kin. All or a portion of this information may be stored in the memory or storage of the device for transmission from the monitor or receiver. Alternatively, a serial number embedded in the data sent from the monitor may be used to link the data with the patient.

[00162] FIG. 22 is an example page for setting parameters in a graphical user interface in accordance with the illustrative embodiments of the present invention. Page 2200 may allow a user to set parameters for the monitoring device or for reviewing the data received. The page 2200 may include the patient information which may specify name, address, contact information, physician, and device information. Page 2200 may also specify monitoring criteria for the monitor.

[00163] Monitor criteria may specify parameters that are to be monitored by the heart and important thresholds that may be significant. Monitor criteria may also specify the monitoring of certain heart events, heart rate, and wave form details. In one example, the monitor may monitor the time intervals, slope, amplitude, and rise time between the PR, QRS, QT, and QS points of the heartbeat waveform. The monitoring criteria may further specify what events are important and what conditions may be ignored.

[00164] FIG. 23 is an example page for a recorded event in a graphical user interface in accordance with illustrative embodiments of the present invention. Page 2300 may be displayed to a user when a heart event or other data has been received. Page 2300 may include a sample, portion or the entire event as recorded by the heart monitor. Page 2300 may specify patient information, the event date, and the type of monitor. The page 2300 may specify the symptoms, measurements, and other findings. For example, the patient may be experiencing an irregular heartbeat. The monitor detects that the patient's heartbeat is irregular and records the data for immediate or subsequent transmission to the receiver. The receiver may transmit the data to a server or directly to the doctor for review. The doctor may use the data to immediately ascertain the seriousness of the situation in order to provide the patient advice or implement additional medical procedures and medication for the good of the patient.

[00165] FIG. 24 is a flowchart of a process of monitoring a patient according to another embodiment of the present invention. The process shown in FIG. 24 can be performed using the monitoring systems described above, for example, as shown in FIGs. 1 and 4-6, or using one or more components thereof. In one embodiment, the process begins with detecting the activity level of the patient (step 2402). In some embodiments, the activity level of the patient is detected using any suitable activity sensor known in the art. In some embodiments, the activity level of the patient is detected using an accelerometer as described in the illustrative embodiments above. In some embodiments, the accelerometer is configured to detect motion of the patient. In some

embodiments, the accelerometer is a piezoelectric accelerometer, such as, for example, accelerometer 436.

[00166] If the detected activity level of the patient is below a preset threshold level for a predetermined amount of time at step 2404 the process proceeds to step 2406 and a series of intramyocardial electrogram (IMEG) signals are collected from the patient. If, on the other hand, the detected activity level of the patient is not below the threshold level for the predetermined amount of time, the process returns to step 2402 and the activity level of the patient is once again detected. In this manner, according to some embodiments, the activity level of the patient can be monitored substantially continuously.

[00167] In preferred embodiments, the preset threshold level and predetermined amount of time are selected to be indicative that the patient is asleep (e.g., alpha sleep) or substantially at rest. For example, in one embodiment, the preset threshold level is selected such that activity levels below the selected threshold level correspond to the activity levels of the patient when the patient is asleep or substantially at rest. Collecting IMEG signals only when the patient is asleep or substantially at rest is crucial, according to some embodiments, because the IMEG signals can be influenced by circadian rhythm and adrenergic status of the patient. Since activity levels when asleep or substantially at rest can vary between different patients, in some embodiments the selection of the preset threshold level is preferably specific to each patient. In some embodiments, the preset threshold level is adjustable, for example, as described above in connection with the embodiments of FIGs. 13 and 14, to account for changes in the patient's condition (e.g., recovering from illness).

[00168] In some embodiments, the activity level as measured by the first derivative of acceleration or activity variance ( $dA/dt$ ) is utilized to determine when the patient is asleep or substantially at rest, for example, when the activity variance ( $dA/dt$ ) is below a preset threshold value for a predetermined amount of time. In other embodiments, a counter coupled with an activity sensor (e.g., accelerometer) is used to record the total number of times motion of the patient is detected by the activity sensor (e.g., accelerometer) during each of a series of consecutive time intervals. In some embodiments, the counter is included as a component of a monitor device implanted in the patient. In some embodiments, the detected activity level of the patient is considered to be below a preset threshold level for a predetermined amount of time when the number recorded by the counter during each of a predetermined number of consecutive time intervals is below a preset value. In some

embodiments, the preset value is determined based on the number recorded by the counter during time intervals when the patient is asleep or substantially at rest. For example, in one embodiment, the counter records the total number of times motion of the patient is detected by the activity sensor (e.g., accelerometer) over consecutive twenty minute intervals. If the number recorded by the counter in this example remains below a preset value for each of two consecutive twenty minute intervals, the patient is considered to be asleep or substantially at rest and the process proceeds to step 2406. In some embodiments, the predetermined number of consecutive time intervals and/or the preset value can be preprogrammed based on individual characteristics of the patient. In some embodiments, the activity sensor (e.g., accelerometer) is also used to collect information relating to the maximum, minimum, and average activity levels of the patient, for example, daily maximum, minimum, and average activity levels of the patient.

**[00169]** FIGs. 25A and 25B are graphs showing example data related to patient activity level detected in accordance with some embodiments of the present invention. FIG. 25A shows the first derivative of activity or activity variance ( $dA/dt$ ) as recorded by an activity sensor (e.g., accelerometer) in one embodiment of the present invention. As shown in this particular example, the collection of IMEG signals is activated between the hours of 12:00 am and 6:00 am when the patient is asleep and the activity variance ( $dA/dt$ ) is consistently low (e.g., below 1.5 in the graph shown). IMEG recording is not taking place during the hours of 8:00 am to 8:00 pm when the activity variance ( $dA/dt$ ) is relatively higher (e.g., above 1.5 in the graph shown). FIG. 25B shows the number of accelerations (e.g. patient motion) detected by an activity sensor (e.g., accelerometer) over a number of intervals of time, according to another embodiment of the present invention. In this particular example, each detected acceleration is represented as a count, and the relatively low count number between sample numbers 5 and 65 are indicative that the patient is sleeping during these time intervals.

**[00170]** Referring back to FIG. 24, step 2406 includes collecting IMEG signals from one or more locations in the patient. In some embodiments, the collected IMEG signals include IMEG signals collected from the right and/or left ventricles (e.g., right and/or left ventricular myocardium) of the patient as described in some of the embodiments above. In some embodiments, the collected IMEG signals include IMEG signals collected from the right ventricular septum of the patient. In some embodiments, the collected IMEG signals include IMEG signals collected from the right ventricular apex of the patient. In some embodiments, the collected IMEG signals include IMEG signals

collected from both the right ventricular septum and the right ventricular apex of the patient. FIG. 26A is a general diagram of the anatomy and conduction system of a human heart and FIGs. 26B and 26C show relative placement of electrodes in the right ventricular septum and right ventricular apex in accordance with some embodiments of the present invention.

[00171] In some embodiments, the IMEG signals are collected at step 2406 using a device programmed to obtain and store the IMEG signals. In some embodiments, the IMEG signals are collected at step 2406 using a device external to the patient. As used herein, the term “external” refers to being positioned outside of a patient’s body. In some embodiments, the IMEG signals are collected at step 2406 using an implantable device implanted in the patient. For example, the implantable device can be a monitor device as described in an embodiment above, such as monitor 104 of FIG. 1, monitor 404 of FIG. 4, and monitor 500 of FIG. 5. In some embodiments, the implantable device includes memory, such as memory 418, for storing the collected IMEG signals and other data. Preferably, the memory is configured to store at least three days worth of IMEG signals. In some embodiments, the memory is configured to store at least seven days worth of IMEG signals. In some embodiments, the implantable device further includes telemetry circuitry (e.g., telemetry circuitry 414), a processor (e.g., processor 420), analog to digital converters and peak detector (e.g., A/D and peak detector 422), and one or more amplifiers (e.g., amplifiers 426, 428, 430, 432, and 434). In some embodiments, the implantable device further includes a temperature sensor, such as thermistor 416, for measuring the temperature of the patient. In preferred embodiments, the temperature sensor has at least a 0.25°C resolution. In some embodiments, the temperature sensor can be used to detect a rise in body temperature (e.g., a fever) which, for example, may be associated with an infection resulting from the surgery used to implant the implantable device itself or due to immunosuppressant medications given to heart transplant patients to control transplant rejection. In some embodiments, the temperature sensor is used to measure maximum, minimum and average body temperatures of the patient (e.g., daily maximum, minimum and average body temperatures), which are stored in the memory for later transmission and/or analysis. In some embodiments, the implantable device is coupled with the activity sensor (e.g., accelerometer) used to detect the activity level of the patient as described above. In some embodiments, the activity sensor (e.g., accelerometer) is a component of the implantable device. As mentioned previously, in some embodiments the implantable device includes a counter for recording the number of times motion is detected by an activity sensor (e.g., accelerometer). On one embodiment, there is a system that includes an implantable device having a memory that is operable

to store programming (e.g., firmware and/or software) that is configured to receive and store the collected IMEG signals and other data described herein. In one embodiment, the system includes at least one processor that is coupled to the memory to execute the program.

[00172] In some embodiments, the implantable device collects the IMEG signals automatically in response to the detected activity level of the patient, for example, when the patient is asleep or substantially at rest. In some embodiments, the implantable device collects the IMEG signals automatically in response to the detected activity level of the patient being below a preset threshold level for a predetermined amount of time. In some embodiments, there is a system that includes an implantable device having memory that is operable to store programming (e.g., firmware or software) that is configured to initiate collection of the IMEG signals automatically in response to the detected activity level of the patient being below a preset threshold level for a predetermined amount of time, for example, when the patient is sleeping or at extreme rest. In some embodiments, the implantable device is further configured to measure the amplitudes of the collected IMEG signals. In some embodiments, the implantable device is further configured to measure the slope or slew rate ( $dV/dt$ ) of the collected IMEG signals. In some embodiments, the implantable device is further configured to measure the time duration (width) of the collected IMEG signals.

[00173] In some embodiments, the IMEG signals are collected using one or more electrode leads coupled to the implanted device. In some embodiments, the accelerometer used to detect the activity level of the patient is included in an electrode lead. In some embodiments, the IMEG signals are collected using one or more electrically active unipolar screw-in electrode leads, for example, as depicted in FIG. 7. Other examples of screw-in electrode leads that can be used in embodiments of the present invention are shown in FIGs. 27A and 27B. In particular, FIG. 27A shows a transvenous extendable/retractable screw-in lead tip. FIG. 27B shows different views of a myocardial screw-in lead, which can be used, for example, for transplant monitoring. In some embodiments, the IMEG signals are collected using one or more unipolar screw-in electrode leads having electrically active screws positioned within the myocardium of the patient, for example, within the muscle tissue of the right ventricular septum and/or right ventricular apex of the patient (e.g., as shown in FIG. 26B and 26C). In other embodiments, for example when used to detect heart transplant rejection, the electrode leads are positioned within the muscle tissue of the right ventricular myocardium and/or the left ventricular myocardium. In some embodiments, the electrode leads coupled to the device include an atrial electrode lead positioned in an atrium of the patient's heart and a ventricular

electrode lead positioned in a ventricle of the patient's heart. Electrically active screw-in electrode leads are preferred for use in some embodiments of the present invention because, in some embodiments, non-electrically active screw-in leads are unable to measure the signals of interest (e.g., IMEG signals) which must be detected from within the heart muscle tissue and not on the surface of the heart muscle tissue. Furthermore, unipolar electrode leads are preferred for use with the present invention because, in some embodiments, the IMEG signal orientation (e.g., positive or negative deflection) sensed by bipolar electrode leads can be unpredictable since it would be based on the relative position of the proximal and distal electrodes.

**[00174]** In some embodiments, a unipolar electrode lead is coupled to the device and configured such that current flows between a cathode situated on the electrode lead and an anode situated on the device itself or a component thereof (e.g., device housing). In some embodiments, a first and second unipolar electrode leads are coupled to the device and configured such that current flows between a cathode situated on the first unipolar electrode lead and an anode situated on the second electrode lead. In some embodiments, an atrial unipolar electrode lead and a ventricular unipolar electrode lead are coupled to the device and configured such that current flows between a cathode situated on the atrial electrode lead and an anode situated on the ventricular electrode lead. In other embodiments, an atrial unipolar electrode lead and a ventricular unipolar electrode lead are coupled to the device and configured such that current flows between a cathode situated on the ventricular electrode lead and an anode situated on the atrial electrode lead. In some embodiments, providing a cathodic ventricular lead and an anodic atrial electrode lead allows both atrial signals (e.g., atrial P-Wave signals) and ventricular signals (e.g., ventricular IMEG signals) to be recorded on the same tracing. Moreover, this configuration according to some embodiments ensures that the ventricular IMEG signal will be recorded as a negative deflection which may allow for easier identification and analysis of the signals.

**[00175]** In some embodiments, the IMEG signals are collected over a fixed programmable length of time, which may be programmed into the implantable device. For example, in one embodiment, a 10 second recording of IMEG signals is made. In other embodiments, the IMEG signals are recorded for a length of time less than or greater than about 10 seconds. In some embodiments, the IMEG signals are recorded for at least about 5 seconds. In some embodiments, the IMEG signals are recorded for at least about 10 seconds. In some embodiments, the IMEG signals are recorded for at least about 15 seconds. In some embodiments, the IMEG signals are recorded for at least about 20

seconds. In some embodiments, the IMEG signals are recorded for at least about 30 seconds. In some embodiments, the IMEG signals are recorded for about or at least about one minute. In other embodiments, the IMEG signals are recorded for a preset number of consecutive heart beats, for example, about five, about ten, or about twenty consecutive heart beats.

[00176] The peak of an action potential within an IMEG can last for about 3 to about 5 msec. In some embodiments, the collected IMEG signals must be filtered at a bandpass having an appropriate upper frequency in order to detect data of interest (e.g., peak amplitudes and  $dV/dt$ ). In some embodiments, the collected IMEG signals are filtered by a component of the implantable device. In some embodiments, the collected IMEG signals are filtered using one or more amplifiers located in the implantable device. In some embodiments, the collected IMEG signals are filtered at a bandpass having an upper end of about 200 Hz. In some embodiments, the collected IMEG signals are filtered at a bandpass having an upper end of at least 200 Hz. In some embodiments, the collected IMEG signals are filtered at a bandpass having an upper end from about 200 Hz to about 250Hz. In some embodiments, the collected IMEG signals are filtered at a bandpass having an upper end from about 200 Hz to about 300Hz. In some embodiments, the collected IMEG signals are filtered at a bandpass having an upper end from about 200 Hz to about 333 Hz. In some embodiments, the collected IMEG signals are filtered at a bandpass having an upper end from about 200 Hz to about 1 kHz. In some embodiments, the collected IMEG signals are filtered at a bandpass having an upper end from about 200 Hz to about 2 kHz. In some embodiments, the collected IMEG signals are filtered at a bandpass having an upper end of about 250 Hz. In some embodiments, the collected IMEG signals are filtered at a bandpass having an upper end of at least 250 Hz. In some embodiments, the collected IMEG signals are filtered at a bandpass having an upper end from about 250 Hz to about 300Hz. In some embodiments, the collected IMEG signals are filtered at a bandpass having an upper end from about 250 Hz to about 333 Hz. In some embodiments, the collected IMEG signals are filtered at a bandpass having an upper end from about 250 Hz to about 1 kHz. In some embodiments, the collected IMEG signals are filtered at a bandpass having an upper end from about 250 Hz to about 2 kHz. In some embodiments of the present invention, the collected IMEG signals are filtered at a bandpass having an upper end of at least 300 Hz. In some embodiments, the collected IMEG signals are filtered at a bandpass having an upper end from about 300 Hz to about 333 Hz. In some embodiments, the collected IMEG signals are filtered at a bandpass having an upper end from about 300 Hz to about 1 kHz. In some embodiments, the collected IMEG signals are filtered at a bandpass having an upper end from about 300 Hz to about 2

kHz. In some embodiments of the present invention, the collected IMEG signals are filtered at a bandpass having an upper end of about 333 Hz. In some embodiments, the collected IMEG signals are filtered at a bandpass having an upper end of at least 333 Hz. In some embodiments, the collected IMEG signals are filtered at a bandpass having an upper end from about 333 Hz to about 1 kHz. In some embodiments, the collected IMEG signals are filtered at a bandpass having an upper end from about 333 Hz to about 2 kHz. In some embodiments of the present invention, the collected IMEG signals are filtered at a bandpass having an upper end of about 1 kHz. In some embodiments, the collected IMEG signals are filtered at a bandpass having an upper end of at least 1 kHz. In some embodiments, the collected IMEG signals are filtered at a bandpass having an upper end from about 1 kHz to about 2 kHz. In some embodiments, the collected IMEG signals are filtered at a bandpass having an upper end of about 2 kHz. In some embodiments, the collected IMEG signals are filtered at a bandpass having an upper end from of at least 2 kHz.

[00177] In some embodiments of the present invention, the collected IMEG signals are filtered at a bandpass having a lower end of about 1 Hz to about 5 Hz. In some embodiments of the present invention, the collected IMEG signals are filtered at a bandpass having a lower end of about 1 Hz to about 4 Hz. In some embodiments of the present invention, the collected IMEG signals are filtered at a bandpass having a lower end of about 1 Hz to about 3 Hz. In some embodiments of the present invention, the collected IMEG signals are filtered at a bandpass having a lower end of about 1 Hz to about 2 Hz. In some embodiments of the present invention, the collected IMEG signals are filtered at a bandpass having a lower end of about 1 Hz. In some embodiments of the present invention, the collected IMEG signals are filtered at a bandpass having a lower end of about 2 Hz to about 5 Hz. In some embodiments of the present invention, the collected IMEG signals are filtered at a bandpass having a lower end of about 2 Hz to about 4 Hz. In some embodiments of the present invention, the collected IMEG signals are filtered at a bandpass having a lower end of about 2 Hz to about 3 Hz. In some embodiments of the present invention, the collected IMEG signals are filtered at a bandpass having a lower end of about 2 Hz. In some embodiments of the present invention, the collected IMEG signals are filtered at a bandpass having a lower end of about 3 Hz to about 5 Hz. In some embodiments of the present invention, the collected IMEG signals are filtered at a bandpass having a lower end of about 3 Hz to about 4 Hz. In some embodiments of the present invention, the collected IMEG signals are filtered at a bandpass having a lower end of about 3 Hz. In some embodiments of the present invention, the collected IMEG signals are filtered at a bandpass having a lower end of about 4 Hz to about 5 Hz. In some embodiments of the present invention, the collected IMEG

signals are filtered at a bandpass having a lower end of about 4 Hz. In some embodiments of the present invention, the collected IMEG signals are filtered at a bandpass having a lower end of about 5 Hz.

[00178] In some embodiments of the present invention, the collected IMEG signals are filtered at a bandpass spanning from about 1 Hz to about 1 kHz. In some embodiments of the present invention, the collected IMEG signals are filtered at a bandpass spanning from about 2 Hz to about 1 kHz. In some embodiments of the present invention, the collected IMEG signals are filtered at a bandpass spanning from about 3 Hz to about 1 kHz. In some embodiments of the present invention, the collected IMEG signals are filtered at a bandpass spanning from about 1 Hz to about 2 kHz. In some embodiments of the present invention, the collected IMEG signals are filtered at a bandpass spanning from about 2 Hz to about 2 kHz. In some embodiments of the present invention, the collected IMEG signals are filtered at a bandpass spanning from about 3 Hz to about 2 kHz. In some embodiments of the present invention, the collected IMEG signals are filtered at a bandpass spanning from about 1 Hz to about 333 Hz. In some embodiments of the present invention, the collected IMEG signals are filtered at a bandpass spanning from about 2 Hz to about 333 Hz. In some embodiments of the present invention, the collected IMEG signals are filtered at a bandpass spanning from about 3 Hz to about 333 Hz. In some embodiments of the present invention, the collected IMEG signals are filtered at a bandpass spanning from about 1 Hz to about 300 Hz. In some embodiments of the present invention, the collected IMEG signals are filtered at a bandpass spanning from about 2 Hz to about 300 Hz. In some embodiments of the present invention, the collected IMEG signals are filtered at a bandpass spanning from about 3 Hz to about 300 Hz. In some embodiments of the present invention, the collected IMEG signals are filtered at a bandpass spanning from about 1 Hz to about 250 Hz. In some embodiments of the present invention, the collected IMEG signals are filtered at a bandpass spanning from about 2 Hz to about 250 Hz. In some embodiments of the present invention, the collected IMEG signals are filtered at a bandpass spanning from about 3 Hz to about 250 Hz. In some embodiments of the present invention, the collected IMEG signals are filtered at a bandpass spanning from about 1 Hz to about 200 Hz. In some embodiments of the present invention, the collected IMEG signals are filtered at a bandpass spanning from about 2 Hz to about 200 Hz. In some embodiments of the present invention, the collected IMEG signals are filtered at a bandpass spanning from about 3 Hz to about 200 Hz.

[00179] In some embodiments, the collected series of IMEG signals are then transmitted to an external system (step 2408) and parameters from at least a portion of the collected series of IMEG signals are then extracted (step 2410). In some embodiments, other data which have also been measured or collected, such as IMEG amplitudes, IMEG slew rate ( $dV/dt$ ), IMEG time duration (IMEG width), patient temperature (e.g., daily maximum, minimum, average), and/or activity levels, are also transmitted to the external system. In some embodiments, data relating to the operation and status of the implantable device (e.g., battery voltage or power, firmware revision, amplifier gain, and/or accelerometer and activity level threshold levels) are also transmitted to the external system. In some embodiments, the external system includes a receiver, such as those described in the embodiments above, configured to receive the collected IMEG signals and other data. For example, mobile receiver 106, transceiver 108 or receiver 402 can be used as the receiver of the external system. In some embodiments, the external system further includes a network, such as network 110, configured to communicate with the receiver and receive data therefrom.

[00180] In some embodiments, the receiver is a bedside monitor which is maintained in the home of the patient. In some embodiments, the receiver is a portable or wearable device such that the receiver can be carried with the patient, for example, during travel. In some embodiments, the receiver is configured to receive the collected IMEG signals and/or other data from the implanted device using any of the means described above (e.g., wirelessly via telemetry). In some embodiments, the receiver is configured to communicate with the implanted device and receive information (e.g., the collected IMEG signals and/or other data) therefrom automatically. In some embodiments, the receiver receives information from the implanted device at regularly scheduled intervals (e.g., once every day or once every hour). In some embodiments, the receiver receives information from the implanted device at preset times (e.g., daily at midnight, etc.). In some embodiments, the receiver receives information from the implanted device in response to an action from the patient or other individual. For example, in some embodiments, the receiver may include a button, switch, or other control which when activated by a user (e.g., the patient), will cause the receiver to download information from the implanted device. In some embodiments, the implantable device attempts to automatically contact the receiver and transmit information thereto whenever there is data in the memory of the implantable device. In some embodiments, if the implantable device fails to successfully send data to the receiver after a predetermined number of attempts or after a predetermined amount of time (e.g., 24 hours), the receiver will prompt the user (e.g., by displaying a message or by an alarm) to activate a button, switch, or other control as described above

to initiate download of the information from the implantable device to the receiver. In some embodiments, the implantable device is configured to clear information from its memory component upon the successful transmission of the information to the receiver so as to make available space for future data.

**[00181]** In some embodiments, the receiver is further configured to retransmit the collected IMEG signals and/or other data to the network component of the external system, such as network 110. The receiver, in some embodiments, includes communications hardware such as a local area network card, modem, etc., to send data to the network. In some embodiments, the receiver is configured to transmit information wirelessly to the network. In some embodiments, the receiver is configured to transmit information to the network via a phone, internet, ethernet, cable, or fiber-optic line. In some embodiments, the receiver further adds or includes a time and date stamp with the transmitted information such that the time of transmission is also recorded. The network, in some embodiments, includes a computer server, such as a remote monitoring company server, configured to receive and store the collected IMEG signals and/or other data transmitted from the receiver. In some embodiments, the computer server is configured to extract parameters from at least a portion of the collected IMEG signals, as in step 2410. In some embodiments, the computer server is further configured send information (e.g., the collected IMEG signals, extracted parameters, or data) or permit access thereto to the patient, the patient's doctor, or other authorized user. In some embodiments, the computer server is further configured to alert the patient, the patient's doctor, or other authorized user if, for example, heart failure is detected from the collected or extracted information. In some embodiments, the computer server includes memory for storage of a program that is (e.g., firmware and/or software) configured to perform all the calculations described herein.

**[00182]** FIG. 28 shows an example of a system in accordance with an embodiment of the present invention which can be used to practice methods described herein. In this example, the system includes a implantable device, such as an Implantable Cardiac Assessment Monitor (ICAM), which is implanted like a pacemaker into a patient having a passive fixation lead in the right atrium (RA) and two active fixation leads, one in the right ventricular septum and one in the right ventricular apex. The system according to this embodiment further includes a receiver, such as bedside monitor, which receives daily IMEG, activity, and temperature data from the implantable device. The receiver sends the data to a company server (e.g., via modem) for analysis, the server then notifies

the patient's doctor if heart failure is detected and places the data on a website for the doctor to view upon secure logon.

**[00183]** Example parameters, according to some embodiments, include amplitude, slope or slew rate ( $dV/dt$ ), time duration values of the IMEG signals, and P-wave – IMEG intervals. FIG. 29 is an example IMEG signal collected in accordance with an embodiment of the present invention showing amplitude, slope or slew rate ( $dV/dt$ ), and time duration (IMEG duration) and P-wave – IMEG interval according to one embodiment. In some embodiments, a parameter is an averaged value for a plurality of IMEG signals (e.g., an average amplitude or average slew rate of a series of IMEG signals). In some embodiments, an “average” or “averaged” value refers to the average of a plurality of averaged values (e.g., an average of the average amplitude or slew rate values of a plurality of series of IMEG signals).

**[00184]** In preferred embodiments, the parameters are extracted from a portion of the collected IMEG signals that includes only normally conducted IMEG signals (e.g., “sinus beats” produced by signal conduction which originates in the SA Node). In some embodiments, the parameters are extracted from a portion of the collected series of IMEG signals that includes only IMEG signals which are each preceded (e.g., immediately preceded) by a P-wave. In some embodiments, the parameters are extracted from a portion of the collected series of IMEG signals that includes only IMEG signals having P-waves between consecutive IMEG signals, for example, as shown in FIG. 30A. In some embodiments, the parameters are extracted from a portion of the collected series of IMEG signals that includes substantially constant P-wave - IMEG intervals (P-IMEG intervals). In some embodiments, the parameters are extracted from a portion of the collected IMEG signals that includes only IMEG signals which are each preceded by a P-wave and have a P-IMEG interval that does not deviate more than about  $\pm 15\%$  from a baseline P-IMEG interval in duration. In some embodiments, the baseline P-IMEG interval is an average or median P-IMEG interval calculated from a series of IMEG signals, preferably from a series of normally conducted IMEG signals. In some embodiments, a normally conducted beat results in P-IMEG intervals that are substantially constant, (e.g., each within about  $\pm 15\%$  of a baseline P-IMEG interval), whereas non-normally conducted beats, e.g. premature ventricular contractions (PVCs) or extrasystoles, can result in variable P-IMEG intervals that are not within acceptable tolerances (e.g., within about  $\pm 15\%$  of a baseline P-IMEG interval). PVCs, for example, can be caused by hypoxia, electrolyte imbalances, drugs, or poorly functioning SA or AV nodes and can result in abnormal IMEG signals. In some

embodiments, non-normally conducted signals (“non-sinus beats”) originate from a location different than the SA node (e.g., the ventricles) and can be distinguished from normally conducted signals (“sinus beats”) by the lack of a P-wave between consecutive IMEG signals, for example, as shown in FIG. 30B. These non-normally conducted beats can have a different vector, be either larger or smaller in amplitude, have a different slew rate, and have different time durations than normally conducted beats. Accordingly, in some embodiments, the use of non-normally conducted IMEG signals in particular measurements and calculations described herein can produce results which are skewed and unreliable in determining the condition (e.g., heart failure status or transplant rejection status) of a patient.

**[00185]** In some embodiments, even though IMEG signals from non-normally conducted beats may not be preferred for use in the particular measurements and calculations described herein, such signals may still be indicative of heart problems and are therefore stored and transmitted as additional data for later review and analysis. For example, the non-sinus beats of FIG. 30B show idioventricular rhythm that occurred after a myocardial infarction (MI). In some embodiments, the devices, systems and methods according to the present invention are useful in detecting the presence of fractionated heart signals (e.g., fractionated ventricular electrograms), which may indicate that a patient is susceptible to arrhythmias. Fractionation may occur when there is a delay in the conduction of cardiac electrical signals resulting asynchronous heart activity. The delay may be caused, for example, by the formation of an infarct. In some embodiments, the detection of two or more IMEG signal peaks immediately following a P-wave signal may indicate the presence of a fractionated heart signal. In some embodiments, the detection of an IMEG signal having two or more peaks, as shown in Fig. 38D, indicates the presence of a fractionated heart signal. The two or more peaks of the fractionated IMEG signal may or may not be of equal amplitude, and may be equal to or less than the amplitude of a normal (i.e., non-fractionated) IMEG signal. Moreover, the duration of a fractionated IMEG signal may be greater than the duration of a normal IMEG signal. In some embodiments, identification of fractionated heart signals requires that the IMEG signals be sampled about once every 0.5 msec to about once every 1 msec in order to record the signal characteristics of interest (e.g., the multiple peaks of a fractionated IMEG signal). In some embodiments, the signals are recorded at a sampling rate of about 1 kHz to about 2 kHz. In some embodiments, the signals are recorded at a sampling rate of at about 1 kHz to about 1.5 kHz. In some embodiments, the signals are recorded at a sampling rate of 1.5 kHz to about 2 kHz. In some embodiments, the signals are recorded at a sampling rate of not greater than 2 kHz. According to

some embodiments, once a fractionated signal is detected, electrophysiology mapping is performed on the patient in order to determine the cause of the fractionation. The detection of fractionated heart signals may be particularly useful, for example, in identifying patients who may benefit from or require an implantable cardiac defibrillator (ICD) or other treatment.

[00186] Referring again to Fig. 24, a method according to some embodiments of the present invention further includes generating one or more status indicator values based on the extracted parameters (step 2412). In some embodiments, the one or more status indicator values are indicative of the heart failure status of the patient. In some embodiments, the status indicator value is a function of one or more of the parameters extracted in step 2410. In some embodiments, the status indicator value is equal to or proportional (e.g., directly proportional) to one or more of the parameters extracted in step 2410. In preferred embodiments, the status indicator value is proportional (e.g., directly proportional) to the combination of two or more parameters extracted in step 2410. In some embodiments, the status indicator value is equal to or proportional to the sum of two or more parameters extracted in step 2410. In some embodiments, the status indicator value is equal to or proportional to the difference of two or more parameters extracted in step 2410. In some embodiments, the status indicator value is equal to or proportional to a ratio of two or more parameters extracted in step 2410. In some preferred embodiments, the status indicator value is equal to or proportional to a product of two or more of the parameters extracted in step 2410. For example, a status indicator value, in some embodiments, is directly proportional to the product of an amplitude value (e.g., an averaged IMEG amplitude) and a slew rate (e.g., an averaged IMEG slew rate) extracted from at least a portion of the collected IMEG signals. In some embodiments, a status indicator value is directly proportional to an amplitude value and a time duration value (e.g., an averaged IMEG time duration) extracted from at least a portion of the collected IMEG signals. In some embodiments, a plurality of status indicator values based on different parameters or combinations of parameters are generated. For example, in some embodiments, at least a first status indicator value proportional to the product of a first parameter (e.g., amplitude) and a second parameter (e.g., slew rate) and a second status indicator value proportional to the product of the first parameter (e.g., amplitude) and a third parameter (e.g., time duration) are generated.

[00187] In some embodiments, steps 2402 to 2412 are repeated such that a plurality of status indicator values is generated over a period of time. For example, in one embodiment, one or more daily status indicators are generated each day. The plurality of status indicator values over time can

then be analyzed, for example, to determine a change in the heart failure status of the patient being monitored. For example, upward and downward trends in the status indicator values over time can be respectively indicative of improvement or deterioration in a patient's heart failure condition whereas plateaus in the status indicator values can indicate relative stability. In some embodiments, a linear trend analysis is performed by the server. In some embodiments, polynomial trend analysis is performed by the server. Analysis, in some embodiments, may also include comparing the trends to additional indicators of heart condition, for example, ejection fraction.

**[00188]** As an illustrative example, in one embodiment a device (e.g., an implantable device) is used to collect a series of IMEG signals (e.g., a 10 second strip of IMEG signals) while the patient is sleeping and measures the amplitude of each of the IMEG signals in the series. The implantable device, in some embodiments, includes memory that is configured to store a computer program that is configured to collect additional data including patient body temperature and patient activity level. The implanted device then transmits the amplitude measurements and any additional data to a system (e.g., an external system) which calculates the average amplitude for the series. These steps are repeated over time (e.g., every five minutes while the patient is sleeping) to collect a plurality of IMEG signal series and to generate an average amplitude value for each series. The system then averages the average amplitude values for the plurality of IMEG signal series in a single day to obtain, for example, a first extracted parameter, IMEG Amplitude<sub>avg</sub><sup>Day1</sup>. The same general process is also used for IMEG Slew Rate ( $dV/dt$ ) to obtain a second extracted parameter, IMEG Slew Rate<sub>avg</sub><sup>Day1</sup>. The same general process is also used for IMEG duration (width) to obtain a third extracted parameter, IMEG Duration<sub>avg</sub><sup>Day1</sup>. The system then generates one or more daily status indicator values based on IMEG Amplitude<sub>avg</sub><sup>Day1</sup>, IMEG Slew Rate<sub>avg</sub><sup>Day1</sup>, IMEG Duration<sub>avg</sub><sup>Day1</sup>. For example, a first daily status indicator, Indicator<sub>1</sub><sup>Day1</sup>, is obtained by multiplying IMEG Amplitude<sub>avg</sub><sup>Day1</sup> and IMEG Slew Rate<sub>avg</sub><sup>Day1</sup> and a second daily status indicator, Indicator<sub>2</sub><sup>Day1</sup>, is obtained by multiplying IMEG Amplitude<sub>avg</sub><sup>Day1</sup> and IMEG Duration<sub>avg</sub><sup>Day1</sup>. The process is then repeated over several days 1 to n to generate Indicator<sub>1</sub><sup>Day2</sup>, Indicator<sub>1</sub><sup>Day3</sup>, ... Indicator<sub>1</sub><sup>Day n</sup>, and Indicator<sub>2</sub><sup>Day2</sup>, Indicator<sub>2</sub><sup>Day3</sup>, ... Indicator<sub>2</sub><sup>Day n</sup>. In some embodiments, where IMEG signals are recorded from different locations of the heart (e.g., right ventricular septum and right ventricular apex), separate status indicator values are generated for each location. For example, in some embodiments, the system is configured to generate Indicator<sub>1</sub> and Indicator<sub>2</sub> values for each of the septum and apex based on IMEG signals recorded from these separate locations. Trends over time

in Indicator<sub>1</sub> and Indicator<sub>2</sub> can then be retrieved and analyzed, e.g., by an authorized doctor or other health care provider, to monitor changes in the heart failure status of the patient.

**[00189]** In some embodiments, a significant decrease over time in the values for Indicator<sub>1</sub> and/or Indicator<sub>2</sub> may indicate a trend towards heart failure, whereas a significant increase over time may indicate an improving heart condition. A stable condition (e.g., significantly little or no change in heart condition) may be indicated when the indicator values stay relatively constant over time. In some embodiments, the system is further configured to generate trend lines (e.g., linear trend lines) for each indicator values over time and to calculate the slopes thereof. A large negative slope, in some embodiments, is indicative of a trend towards heart failure, whereas a large positive slope is indicative of improving heart condition, and a slope having a value close to about zero indicates a relatively stable condition. In other embodiments, where the patient has received a heart transplant, a significant decrease over time in the values for Indicator<sub>1</sub> and/or Indicator<sub>2</sub> may indicate transplant rejection. In some embodiments, the system is configured to generate a combined slope value which is the function of two or more trend line slopes. For example, in some embodiments, the slope values of two or more trend lines may be added or multiplied to produce a combined slope value.

**[00190]** In some embodiments, the system includes a bedside monitor configured to wirelessly receive collected IMEG signal data from the device and a remote server configured to receive the collected IMEG signal data from the bedside monitor (e.g., via a modem) and provided with programming (e.g., firmware and/or software) configured to perform some or all the calculations described herein. In some embodiments, the programming is provided on a computer readable medium. The programming in some embodiments is configured to calculate the average IMEG amplitude, the average IMEG slew rate, and the average IMEG duration values as described. In some embodiments, the programming is further configured to calculate the status indicator values, generate trend lines for each status indicator value over time, and determine the slope of the trend lines.

**[00191]** In some embodiments, the status indicator values and/or other data can be made available by the server to a user (e.g., patient, doctor, or other authorized individual) for viewing or analysis. In some embodiments, the server includes a memory for storing a program that is configured to provide access to the data upon input from the user. In some embodiments, for example, the data may be accessed via a website upon secure logon by the user. In other embodiments, the data may

be sent by the server to the user's phone, PDA, or other personal electronic device for viewing. In some embodiments, the data is provided to a user via Email or other suitable form of communication known in the art (e.g., via printed reports, facsimile, telephone, VoIP, text message, etc.). In some embodiments, the data is presented as graphs or charts which can be configured to meet the user's particular preferences. In some embodiments, the server is configured to send an alert (e.g., by phone or Email) to the user if the status indicator values or other data indicate a change in the patient's condition. In some embodiments, the server is further provided with a memory having a program configured to detect abnormalities in a patient's IMEG signal data, for example, non-sinus beats or fractionated heart signals. In some embodiments, the server includes a memory with a program configured to send an alert to the patient or the patient's healthcare provider if an abnormality is detected.

**[00192]** FIGs. 31A-31D show example data which is collected, stored and transmitted in accordance with some embodiments of the present invention. FIG. 31A shows, for example, daily maximum, minimum, and average activity level of a patient over a period of 30 days. FIG. 31B shows, for example, daily maximum, minimum, and average body temperature over a period of 30 days. FIG. 31C shows, for example, daily maximum, minimum, and average IMEG amplitudes over a period of 30 days. FIG. 31D shows, for example, a single series of IMEG signals collected at a particular day and time from which values such as amplitude and slew rate can be measured or calculated.

**[00193]** FIGs. 32A and 32B show additional example data which can be presented in accordance with embodiments of the present invention. FIG. 32A shows a linear trend analysis performed on a server showing a downward trend in IMEG amplitude, which can be used to determine the change in the heart failure status of a patient. In this particular example, the downward trend correlates with a decrease in ejection fraction, suggestive of increasing heart failure. FIG. 32B shows a polynomial trend analysis performed on a server showing a general downward trend in IMEG amplitude. Again in this embodiment, the downward trend correlates with a decrease in ejection fraction, suggestive of increasing heart failure. The slight upward slope of the polynomial trend may possibly suggest remodeling of the heart chamber where the electrode is located.

**[00194]** A method according to some embodiments of the present invention further includes measuring a time difference (e.g., time delay) between IMEG signals collected from one location of

the patient (e.g., right ventricular septum) and IMEG signals collected from a second location of the patient (e.g., right ventricular apex). FIG. 33 shows, for example, representations of a septal IMEG signal (e.g., from right ventricular septum) and an apical IMEG signal (e.g., from the right ventricular apex) and the time difference between them. In one embodiment, the time difference corresponds to the transit time of an IMEG signal as it is conducted from one location of the patient (e.g., right ventricular septum) to a second location of the patient (e.g., right ventricular apex). This, for example, can be used to measure and detect changes in the nerve-muscle cell signal transit time between two differently positioned electrode leads. In some embodiments, a change in the transit time of the IMEG signals from one or more locations of the heart may be indicative of a change in the heart failure status of the patient. FIG. 34, for example, shows septal and apical IMEG signals collected at different times in accordance with an embodiment present invention. As can be seen in the figure, the transit time of the septal IMEG signals decreased whereas the transit time of the apical IMEG signals remained substantially unchanged.

**[00195]** In one embodiment, a method of the present invention includes detecting the activity level of the patient and using a device implanted in the patient to automatically collect a series of IMEG signals from the right ventricular septum and the right ventricular apex of the patient if the detected activity level of the patient is below a preset threshold level for a predetermined amount of time, for example as described in the embodiments above, and further using the external system to measure time differences between the IMEG signals collected from the right ventricular septum of the patient and the IMEG signals collected from the right ventricular apex. One variation of this embodiment further includes analyzing changes in the measured time differences at different time points between the IMEG signals collected from the right ventricular septum of the patient and the IMEG signals collected from the right ventricular apex to determine a change in the heart failure status of the patient. In one variation, the IMEG signals are collected from the right ventricular myocardium and the left ventricular myocardium instead of or in addition to the right ventricular septum and the right ventricular apex.

**[00196]** In yet another embodiment of the present invention, a method includes detecting an activity level of the patient, automatically collecting a series of IMEG signals from a right ventricular septum and a right ventricular apex of the patient if the detected activity level of the patient is below a preset threshold value for a predetermined amount of time, transmitting the collected series of IMEG signals to a system external to the patient, for example as described in the

embodiments above, and using the external system to measure a time delay value between IMEG signals from the right ventricular septum and IMEG signals from the right ventricular apex. In some embodiments, steps are repeated to collect a plurality of time delay values which can be analyzed to determine a change in the heart failure status of the patient. In one variation, the IMEG signals are collected from the right ventricular myocardium and the left ventricular myocardium instead of or in addition to the right ventricular septum and the right ventricular apex.

**[00197]** EXAMPLE

**[00198]** Each of three canine subjects (Dog 1, Dog 2, and Dog 3) was implanted with an Implantable Cardiac Assessment Monitor (ICAM) heart monitoring device in accordance with embodiments of the present invention. The heart monitoring devices were coupled to screw-in electrode leads positioned to record IMEG signals from the right ventricular septum (Septal IMEG) and right ventricular apex (Apical IMEG).

**[00199]** Microembolization procedures were performed on two of the subjects (Dog 1 and Dog 3) in order to induce heart failure (HF) over time, while the third subject (Dog 2) was selected as a control animal and did not undergo embolization. Embolization was performed by injecting silicone microspheres into the arteries of Dog 1 and Dog 3 in order to reduce blood flow to portions of the subjects' hearts, thereby causing infarction.

**[00200]** Cardiac data as described herein were recorded by the implanted heart monitoring devices and transmitted wirelessly to external bedside monitors, which in turn transmitted the data to a remote server using an integral modem. IMEG data including IMEG amplitude, duration, and slew rate ( $dV/dt$ ) were made accessible to designated recipients via a website requiring a secure login for access to the server. Example data presented on the website are shown in Figs. 35A-37D.

**[00201]** Figs. 35A-35D show data obtained from Dog 2 (control) over a period of several weeks. Fig. 35A shows the product of Septal IMEG Amplitude and Septal IMEG Duration over time. Fig. 35B shows the product Septal IMEG Amplitude and Septal IMEG  $dV/dt$  over time. Fig. 35C shows the product Apical IMEG amplitude and Apical IMEG Duration over time. Fig. 35D shows the product of Apical IMEG Amplitude and Apical IMEG  $dV/dt$  over time.

**[00202]** Figs. 36A-36D show data obtained from Dog 1 (embolized) over the same period of time. Fig. 36A shows the product of Septal IMEG Amplitude and Septal IMEG Duration over time. Fig.

36B shows the product Septal IMEG Amplitude and Septal IMEG  $dV/dt$  over time. Fig. 36C shows the product Apical IMEG amplitude and Apical IMEG Duration over time. Fig. 36D shows the product of Apical IMEG Amplitude and Apical IMEG  $dV/dt$  over time.

[00203] The slopes values of the trend lines for the data obtained from Dog 1 and Dog 2 are summarized in the table below. The combined septal slope values in this example were obtained by adding the slope values obtained from the septal IMEG data. The combined apical slope values in this example were obtained by adding the slope values obtained from the apical IMEG data.

**Table I:**

Indicator	Trend Line Slope Value	
	Dog 1 (embolized)	Dog 2 (control)
Septal IMEG Amplitude × Septal IMEG Duration	-9.8	-2.0
Septal IMEG Amplitude × Septal IMEG $dV/dt$	-3.0	-0.8
Combined Septal Slope Value	-12.8	-2.8
Apical IMEG Amplitude × Apical IMEG Duration	-17.2	-0.2
Apical IMEG Amplitude × Apical IMEG $dV/dt$	-4.2	-0.5
Combined Apical Slope Value	-21.4	-0.7

[00204] The trend lines shown in Figs. 36A-36D for Dog 1 (embolized) demonstrate negative slope values which are significantly greater in magnitude in comparison to the slopes values of the trend lines shown in Figs. 35A-35D for Dog 2 (control). These slope values are indicative of a deteriorating cardiac status in Dog 1 leading towards heart failure. In contrast, the lower magnitude slope values for Dog 2 indicate a more stable heart condition.

[00205] Figs. 37A-37C show IMEG signal tracings recorded from the right ventricular septum of Dog 1, Dog 2, and Dog 3, respectively. The signal tracing of Fig. 37A (Dog 1) and Fig. 37B (Dog 2) shows the presence of normal IMEG signals. Fig 37C (Dog 3), however, shows the presence of fractionated IMEG signals. The fractionated ventricular electrogram suggests the subject (Dog 3) may have had an infarct related to its embolization procedures. In order to confirm the fractionation, the IMEG recordings were reviewed using LABVIEW software, an engineering tool useful to provide detailed view of the IMEG signals. Fig. 38A shows a LABVIEW picture of the septal IMEG recording from Dog 1. Fig. 38B shows a LABVIEW picture of the septal IMEG recording from Dog 3 prior to embolization. Fig. 38C shows a LABVIEW picture of the septal IMEG recording from Dog 3 after embolization, which confirms the post-embolization fractionation of the right ventricular septal IMEG. Fig. 38D is a detail from Fig. 38C showing a fractionated IMEG signal having more than two peaks following a non-fractionated P-wave. Moreover, as can be seen in Figs. 38C and 38D, the IMEG signals have decreased in amplitude so significantly that the atrial P-waves are now notably larger than the IMEG signals. Given that the infarct has caused an intra-ventricular conduction delay, it is believed that Dog 3 may be prone to a possible re-entrant tachyarrhythmia or sudden death from ventricular fibrillation and may develop a significant spontaneous rhythm issue, with or without additional embolization procedures.

[00206] While the invention has been described with respect to particular embodiments, modifications and substitutions within the spirit and scope of the invention will be apparent to those of skill in the art. It should be apparent that individual elements identified herein as belonging to a particular embodiment may be included in other embodiments of the invention. The present invention may be embodied in other specific forms without departing from the central attributes thereof. Therefore, the illustrated and described embodiments and examples should be considered in all respects as illustrative and not restrictive, reference being made to the appended claims to indicate the scope of the invention.

What is claimed:

1. A method of monitoring the heart failure status of a patient comprising:  
detecting an activity level of the patient;  
collecting intramyocardial electrogram (IMEG) signals from the patient at different times automatically when the detected activity level of the patient is below a preset threshold level for a predetermined amount of time using a device implanted in the patient, the collected IMEG signals including IMEG signals collected from the right ventricular septum of the patient; and  
generating a status indicator value directly proportional to a product of an average slew rate and an average amplitude of at least a portion of the collected IMEG signals using a system external to the patient.
2. The method of claim 1, further comprising filtering the collected IMEG signals at a bandpass having an upper end of at least 200 Hz.
3. The method of claim 2, wherein the bandpass has an upper end of at least 300 Hz.
4. The method of claim 3, wherein the bandpass has a lower end of about 2 Hz to about 3 Hz.
5. The method of claim 1, wherein the IMEG signals are collected using a unipolar screw-in electrode lead coupled to the implanted device and comprising an electrically active screw positioned within the myocardium of the patient.
6. The method of claim 1, wherein the activity level of the patient is detected using an accelerometer configured to detect motion of the patient.
7. The method of claim 6, wherein the implanted device includes a counter which records the total number of times motion of the patient is detected by the accelerometer during each of a series of consecutive time intervals.
8. The method of claim 7, wherein the detected activity level of the patient is below a preset threshold level for a predetermined amount of time when the number recorded by the counter during each of a predetermined number of consecutive time intervals is below a preset value.

9. The method of claim 8, wherein the preset value is determined based on the number recorded by the counter during time intervals when the patient is asleep or substantially at rest.
10. The method of claim 1, wherein the implanted device collects IMEG signals over a fixed programmable period of time from the patient at different times automatically when the detected activity level of the patient is below a preset threshold level for a predetermined amount of time.
11. The method of claim 1, wherein the collected IMEG signals further include IMEG signals collected from the right ventricular apex of the patient.
12. The method of claim 11, further comprising using the system external to the patient to measure time differences between IMEG signals collected from the right ventricular septum of the patient and IMEG signals collected from the right ventricular apex.
13. The method of claim 1, further comprising using the system external to the patient to measure a time duration of each of the at least a portion of the collected IMEG signals.
14. The method of claim 1, wherein the at least a portion of the collected IMEG signals includes only IMEG signals which have a P-IMEG interval that does not deviate more than about  $\pm 15\%$  from a baseline P-IMEG interval.
15. The method of claim 1, wherein the at least a portion of the collected IMEG signals includes only normally conducted IMEG signals.
16. The method of claim 1, wherein the collected IMEG signals are unipolar IMEG signals.
17. The method of claim 1, wherein the system external to the patient comprises:
  - a receiver configured to receive the collected IMEG signals from the implanted device; and
  - a remote server configured to receive the collected IMEG signals from the receiver.

18. The method of claim 17, wherein the receiver is configured to receive the collected IMEG signals from the implanted device via telemetry.
19. The method of claim 17, wherein the receiver is configured to receive the collected IMEG signals from the implanted device at predetermined times.
20. The method of claim 17, wherein the remote server is configured to receive the collected IMEG signals from the receiver at predetermined times.
21. A method of monitoring the heart failure status of a patient comprising:
- a) detecting an activity level of the patient;
  - b) automatically collecting a series of intramyocardial electrogram (IMEG) signals from the patient if the detected activity level of the patient is below a preset threshold level for a predetermined amount of time, wherein the collected series of IMEG signals includes IMEG signals collected from the right ventricular septum of the patient;
  - c) transmitting the collected series of IMEG signals to a system external to the patient;
  - d) extracting a first parameter and a second parameter from at least a portion of the collected series of IMEG signals using the external system;
  - e) generating a status indicator value that is directly proportional to the product of the first parameter and the second parameter;
  - f) repeating steps a) through e) at different times to generate a plurality of status indicator values from the patient; and
  - g) analyzing the plurality of status indicator values to determine a change in the heart failure status of the patient.
22. The method of claim 21, wherein collecting the series of IMEG signals includes filtering the IMEG signals at a bandpass having an upper end of at least 200 Hz.
23. The method of claim 22, wherein collecting the series of IMEG signals includes filtering the IMEG signals at a bandpass having an upper end of at least 300 Hz.
24. The method of claim 23, wherein the bandpass has a lower end of about 2 Hz to about 3 Hz.

25. The method of claim 21, wherein the series of IMEG signals are collected using a unipolar screw-in electrode lead comprising an electrically active screw positioned within the myocardium of the patient.
26. The method of claim 21, wherein detecting the activity level of the patient includes:  
detecting motion of the patient using an accelerometer; and  
using a counter to record the total number of times motion of the patient is detected by the accelerometer during each of a series of consecutive time intervals.
27. The method of claim 26, wherein the detected activity level of the patient is below a preset threshold level for a predetermined amount of time when the number recorded by the counter during each of a predetermined number of consecutive time intervals is below a preset value.
28. The method of claim 27, wherein the preset value is determined based on the number recorded by the counter during time intervals when the patient is asleep or substantially at rest.
29. The method of claim 21, wherein the first parameter comprises an average amplitude of the IMEG signals and the second parameter comprises an average slew rate of the IMEG signals.
30. The method of claim 21, wherein analyzing the plurality of status indicator values includes examining one or more trends in the plurality of status indicator values over time.
31. The method of claim 21, wherein the collected series of IMEG signals includes IMEG signals collected from the right ventricular apex of the patient.
32. The method of claim 31, further comprising measuring time differences between IMEG signals collected from the right ventricular septum of the patient and IMEG signals collected from the right ventricular apex.
33. The method of claim 32, further comprising analyzing changes in the measured time differences between the IMEG signals collected from the right ventricular septum of the patient and

the IMEG signals collected from the right ventricular apex to determine a change in the heart failure status of the patient.

34. The method of claim 21, wherein step d) further comprises extracting a third parameter from the at least a portion of the collected series of IMEG signals.

35. The method of claim 34, wherein step e) further comprises generating a second status indicator value that is directly proportional to the product of the first parameter and the third parameter.

36. The method of claim 35, wherein the first parameter comprises an average amplitude of the IMEG signals and the third parameter comprises a time duration of the IMEG signals.

37. The method of claim 21, wherein the at least a portion of the collected series of IMEG signals includes only IMEG signals which have a P-IMEG interval that does not deviate more than about  $\pm 15\%$  from a baseline P-IMEG interval.

38. The method of claim 21, wherein the at least a portion of the collected series of IMEG signals includes only normally conducted IMEG signals.

39. The method of claim 21, wherein the collected series of IMEG signals are unipolar IMEG signals.

40. The method of claim 21, wherein the series of IMEG signals are collected from the patient over fixed programmable periods of time using a device implanted in the patient automatically if the detected activity level of the patient is below a preset threshold level for a predetermined amount of time.

41. A system for monitoring the heart failure status of a patient comprising:  
an activity sensor configured to detect an activity level of the patient;  
an implantable device coupled to the activity sensor and configured to automatically collect a series of intramyocardial electrogram (IMEG) signals from the right ventricular septum of the

patient if the activity level of the patient detected by the activity sensor is below a preset threshold level for a predetermined amount of time; and

a device external to the patient configured to receive the collected series of IMEG signals, extract a first parameter from at least a portion of the collected series of IMEG signals, extract a second parameter from the at least a portion of the collected series of IMEG signals, and calculate a status indicator value that is directly proportional to the product of the first parameter and the second parameter.

42. The system of claim 41, wherein the implantable device comprises an amplifier configured to filter the series of IMEG signals at a bandpass having an upper end of at least 200 Hz.

43. The system of claim 41, wherein the implantable device comprises an amplifier configured to filter the series of IMEG signals at a bandpass having an upper end of at least 300 Hz.

44. The system of claim 43, wherein the amplifier is configured to filter the series of IMEG signals at a bandpass having a lower end of about 2 Hz to about 3 Hz.

45. The system of claim 41, wherein the implantable device is coupled to a unipolar screw-in electrode lead comprising an electrically active screw configured to detect the IMEG signals from the right ventricular septum of the patient.

46. The system of claim 41, wherein the activity sensor comprises an accelerometer configured to detect motion of the patient.

47. The system of claim 46, wherein the system further comprises a counter coupled to the accelerometer and configured to record the total number of times motion of the patient is detected by the accelerometer during each of a series of consecutive time intervals.

48. The system of claim 47, wherein the implantable device is configured to automatically collect the series of IMEG signals if the number recorded by the counter during each of a predetermined number of consecutive time intervals is below a preset value.

49. The system of claim 41, wherein the first parameter comprises an average amplitude of the IMEG signals and the second parameter comprises an average slew rate of the IMEG signals.
50. The system of claim 41, wherein the device external to the patient is further configured to extract a third parameter from the at least a portion of the collected series of IMEG signals.
51. The system of claim 50, wherein the device external to the patient is further configured to generate a second status indicator value directly proportional to the product of the first parameter and the third parameter.
52. The system of claim 51, wherein the first parameter comprises an average amplitude of the IMEG signals and the third parameter comprises a time duration of the IMEG signals.
53. The system of claim 41, wherein the at least a portion of the collected series of IMEG signals includes only IMEG signals which have a P-IMEG interval that does not deviate more than about  $\pm 15\%$  from a baseline P-IMEG interval.
54. The system of claim 41, wherein the at least a portion of the collected series of IMEG signals includes only normally conducted IMEG signals.
55. The system of claim 41, wherein the collected series of IMEG signals are unipolar IMEG signals.
56. The system of claim 41, wherein the implantable device is configured to automatically collect a series of IMEG signals over a fixed programmable period of time.
57. The system of claim 41, wherein the implantable device is further configured to automatically collect a series of IMEG signals from the right ventricular apex of the patient if the activity level of the patient detected by the activity sensor is below a preset threshold level for a predetermined amount of time.

58. The system of claim 57, wherein the device external to the patient is further configured to measure time differences between IMEG signals collected from the right ventricular septum of the patient and IMEG signals collected from the right ventricular apex.
59. The system of claim 51, further comprising a receiver configured to receive the collected series of IMEG signals from the implantable device.
60. The system of claim 58, wherein the device external to the patient comprises a remote server configured to receive the collected series of IMEG signals from the receiver.
61. A method of monitoring the heart failure status of a patient comprising:  
detecting an activity level of the patient;  
using a device implanted in the patient to automatically collect a series of intramyocardial electrogram (IMEG) signals from the right ventricular septum and the right ventricular apex of the patient if the detected activity level of the patient is below a preset threshold level for a predetermined amount of time; and  
using a device external to the patient to measure time differences between the IMEG signals collected from the right ventricular septum of the patient and the IMEG signals collected from the right ventricular apex.
62. The method of claim 61, further comprising analyzing changes in the measured time differences between the IMEG signals collected from the right ventricular septum of the patient and the IMEG signals collected from the right ventricular apex to determine a change in the heart failure status of the patient.
63. The method of claim 61, wherein the activity level of the patient is detected using an accelerometer configured to detect motion of the patient.
64. The method of claim 63, wherein the implanted device includes a counter which records the total number of times motion of the patient is detected by the accelerometer during each of a series of consecutive time intervals.

65. The method of claim 64, wherein the detected activity level of the patient is below a preset threshold level for a predetermined amount of time when the number recorded by the counter during each of a predetermined number of consecutive time intervals is below a preset value.
66. The method of claim 65, wherein the preset value is determined based on the number recorded by the counter during time intervals when the patient is asleep or substantially at rest.
67. The method of claim 61, wherein the IMEG signals have been filtered at a bandpass having an upper end of at least 200 Hz.
68. The method of claim 61, wherein the IMEG signals have been filtered at a bandpass having an upper end of at least 300 Hz.
69. The method of claim 61, wherein the time differences are time delays between the IMEG signals collected from the right ventricular septum of the patient and the IMEG signals collected from the right ventricular apex.
70. The method of claim 61, wherein the collected IMEG signals are synchronized unipolar IMEG signals.
71. A method of monitoring the heart failure status of a patient comprising:
- a) detecting an activity level of the patient;
  - b) automatically collecting a series of intramyocardial electrogram (IMEG) signals from a right ventricular septum and a right ventricular apex of the patient if the detected activity level of the patient is below a preset threshold value for a predetermined amount of time;
  - c) transmitting the collected series of IMEG signals to a system external to the patient;
  - d) measuring a time delay value between IMEG signals from the right ventricular septum and IMEG signals from the right ventricular apex using the external system;
  - e) repeating steps a) through d) at different times to measure a plurality of time delay values from the patient; and
  - f) analyzing the plurality of time delay values to determine a change in the heart failure status of the patient.

72. A method of monitoring a patient comprising:
- a) detecting an activity level of the patient;
  - b) using a device to collect intramyocardial electrogram (IMEG) signals from the patient automatically when the detected activity level of the patient is below a preset threshold level for a predetermined amount of time; and
  - c) using a device to generate a status indicator value directly proportional to a product of a first parameter and a second parameter from at least a portion of the collected IMEG signals.
73. The method of claim 72, further comprising filtering the collected IMEG signals at a bandpass having an upper end of at least 200 Hz.
74. The method of claim 72, wherein the bandpass has an upper end of at least 300 Hz.
75. The method of claim 73, wherein the bandpass has a lower end of about 2 Hz to about 3 Hz.
76. The method of claim 72, wherein the device used to collect IMEG signals from the patient is an implantable device implanted in the patient.
77. The method of claim 76, wherein the activity level of the patient is detected using an activity sensor configured to detect motion of the patient.
78. The method of claim 77, wherein the implantable device includes a counter which records the total number of times motion of the patient is detected by the activity sensor during each of a series of consecutive time intervals.
79. The method of claim 78, wherein the detected activity level of the patient is below a preset threshold level for a predetermined amount of time when the number recorded by the counter during each of a predetermined number of consecutive time intervals is below a preset value.
80. The method of claim 79, wherein the preset value is determined based on the number recorded by the counter during time intervals when the patient is asleep or substantially at rest.

81. The method of claim 77, wherein the activity sensor is an accelerometer.
82. The method of claim 72, wherein the device used to collect IMEG signals from the patient is configured to collect IMEG signals over a fixed programmable period of time from the patient at different times automatically when the detected activity level of the patient is below a preset threshold level for a predetermined amount of time.
83. The method of claim 82, wherein the fixed programmable period of time is about 10 seconds.
84. The method of claim 82, wherein the fixed programmable period of time is at least about 10 seconds.
85. The method of claim 72, wherein the collected IMEG signals include IMEG signals from the right ventricular septum of the patient.
86. The method of claim 72, wherein the collected IMEG signals include IMEG signals from the right ventricular apex of the patient.
87. The method of claim 72, wherein the collected IMEG signals include IMEG signals from the right ventricular septum and the right ventricular apex of the patient.
88. The method of claim 72, wherein the collected IMEG signals include IMEG signals from the right ventricular myocardium of the patient.
89. The method of claim 72, wherein the collected IMEG signals include IMEG signals from the left ventricular myocardium of the patient.
90. The method of claim 72, wherein the device used to generate a status indicator value is external to the patient.
91. The method of claim 72, wherein the device used to generate a status indicator value is a component of a system external to the patient.

92. The method of claim 72, wherein the collected IMEG signals include IMEG signals from a first location of the patient and IMEG signals from a second location of the patient; and wherein the method further includes measuring time differences between IMEG signals collected from the first location of the patient and IMEG signals from the second location of the patient.
93. The method of claim 92, wherein the first location of the patient is the right ventricular septum of the patient and the second location of the patient is the right ventricular apex of the patient.
94. The method of claim 92, wherein the first location of the patient is the right ventricular myocardium of the patient and the second location of the patient is the left ventricular myocardium of the patient.
95. The method of claim 72, wherein the first parameter is an IMEG amplitude value.
96. The method of claim 95, wherein the first parameter is an averaged IMEG amplitude value.
97. The method of claim 95, wherein the second parameter is an IMEG slew rate value.
98. The method of claim 97, wherein the second parameter is an averaged IMEG slew rate value.
99. The method of claim 95, wherein the second parameter is an IMEG time duration value.
100. The method of claim 99, wherein the second parameter is an averaged IMEG time duration value.
101. The method of claim 72, wherein the at least a portion of the collected IMEG signals includes only normally conducted IMEG signals.

102. The method of claim 91, wherein the system external to the patient includes a receiver configured to receive the collected IMEG signals from the device used to collect IMEG signals from the patient, and further configured to transmit the received collected IMEG signals to the device used to generate the status indicator value.

103. The method of claim 102, wherein the device used to generate the status indicator value is a server configured to receive the collected IMEG signals from the receiver via a network.

104. The method of claim 72, further comprising using a device to generate a second status indicator value directly proportional to a product of the first parameter and a third parameter from at least a portion of the collected IMEG signals.

105. The method of claim 104, wherein the first parameter is an IMEG amplitude value, the second parameter is an IMEG slew rate value, and the third parameter is an IMEG time duration value.

106. The method of claim 104, wherein the device used to generate the first status indicator is the same device used to generate the second status indicator value.

107. The method of claim 72, wherein the device used to generate the status indicator value is the same device used to collect IMEG signals from the patient.

108. The method of claim 72, wherein the method comprises using a device to collect IMEG signals from the patient at different times automatically only when the detected activity level of the patient is below a preset threshold level for a predetermined amount of time

109. The method of claim 72, wherein the detected activity level of the patient is below the preset threshold level only when the patient is asleep or substantially at rest.

110. The method of claim 72, further comprising repeating steps a) through c) at different times to generate a plurality of status indicator values over time.

111. The method of claim 110, wherein steps a) through c) are repeated on different days.

112. The method of claim 110, further comprising using a device to analyze trends in the plurality of status indicator values over time.

113. The method of claim 112, wherein the device used to analyze trends over time in the daily status indicator values is the same device used to generate the status indicator values.

FIG. 1

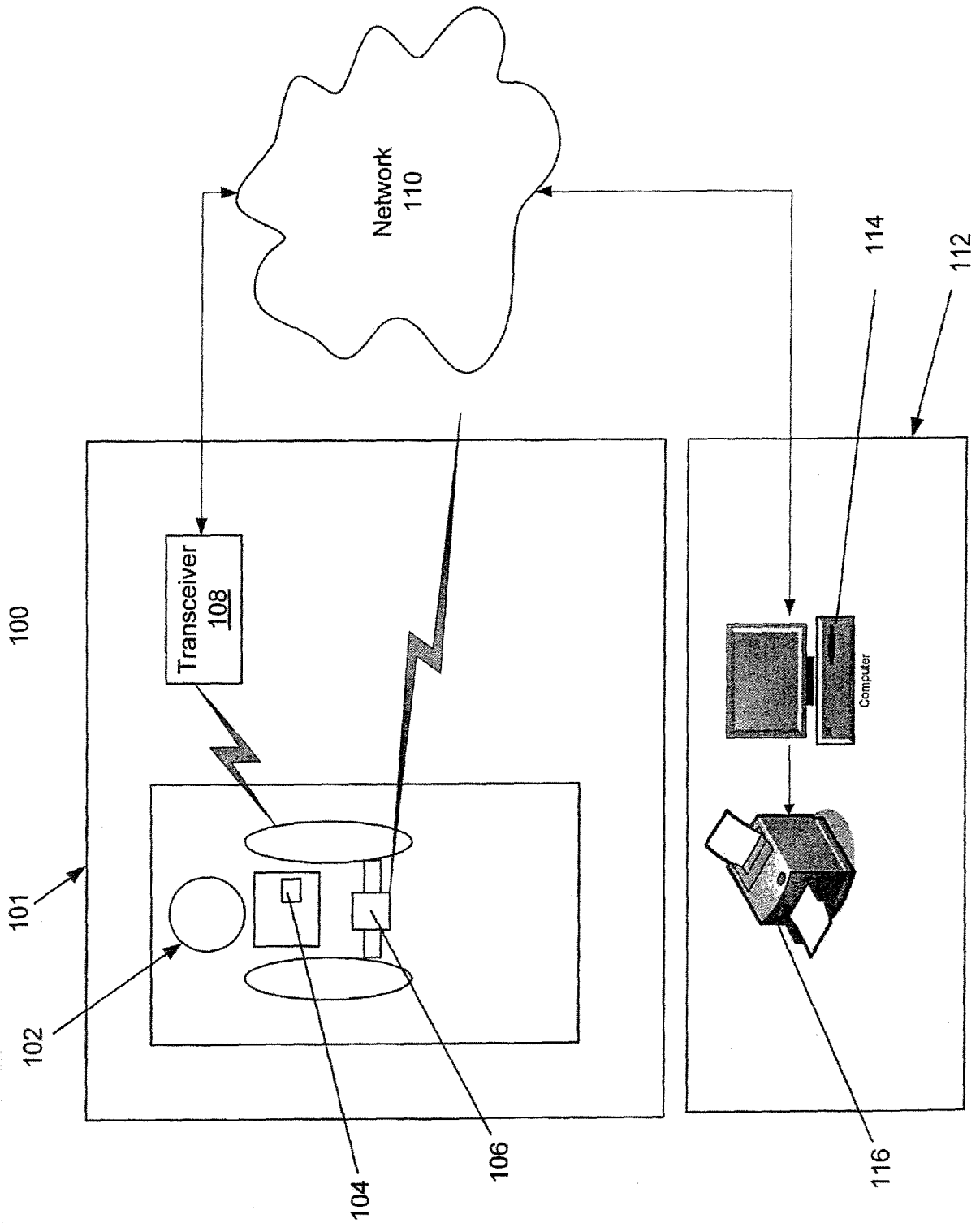

FIG. 2A

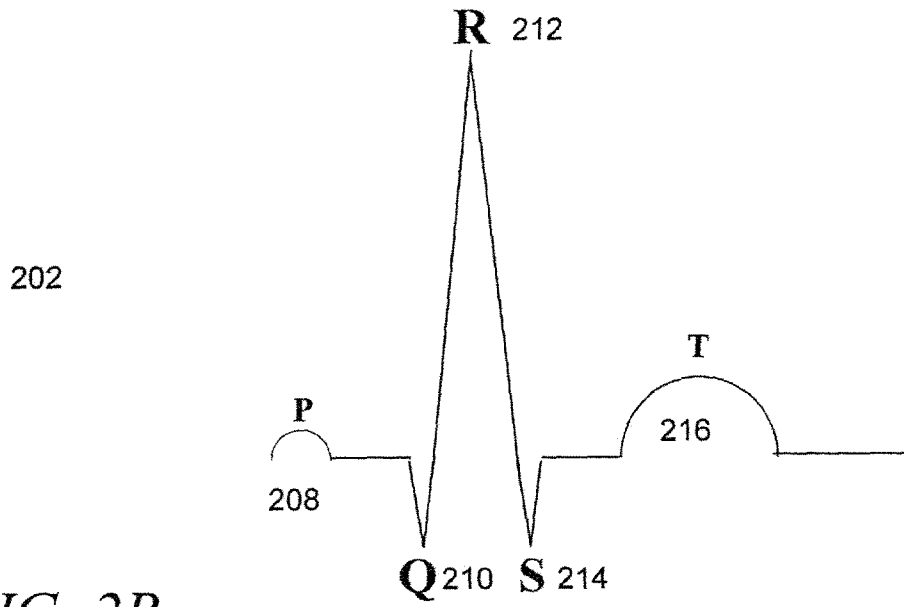

FIG. 2B

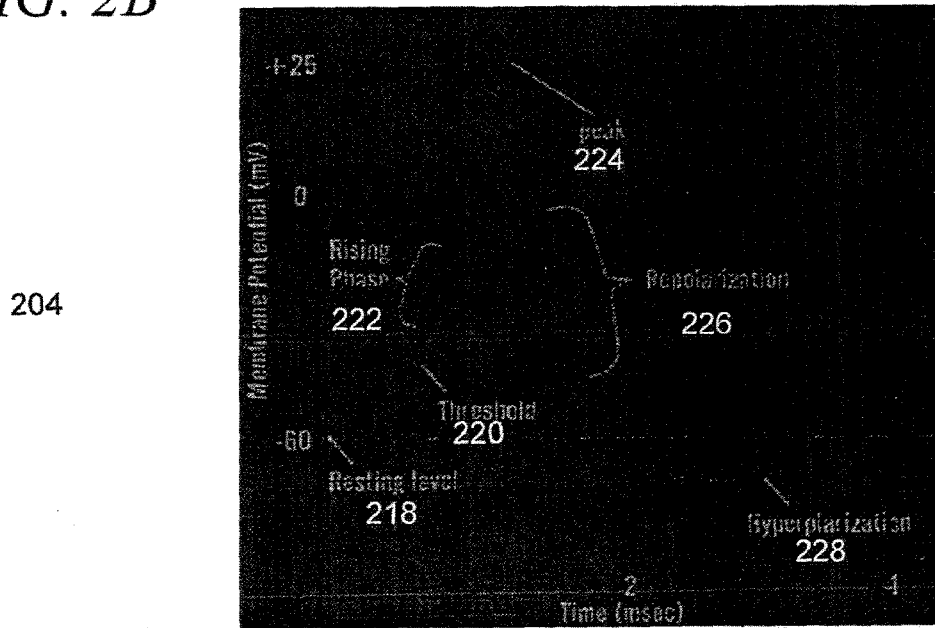

FIG. 2C

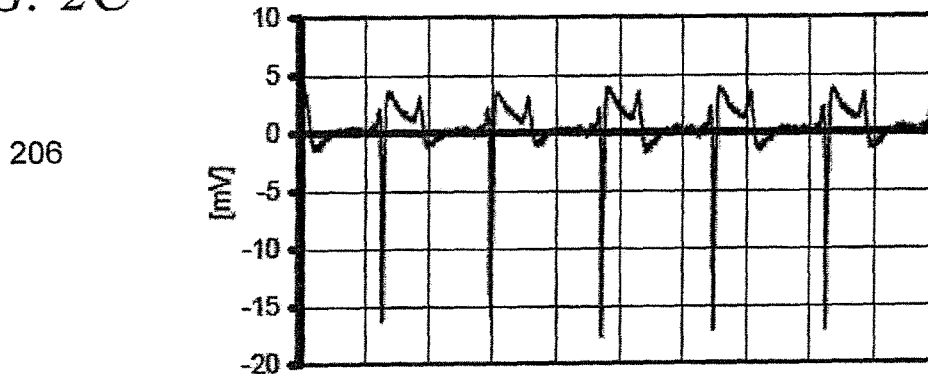

FIG. 3

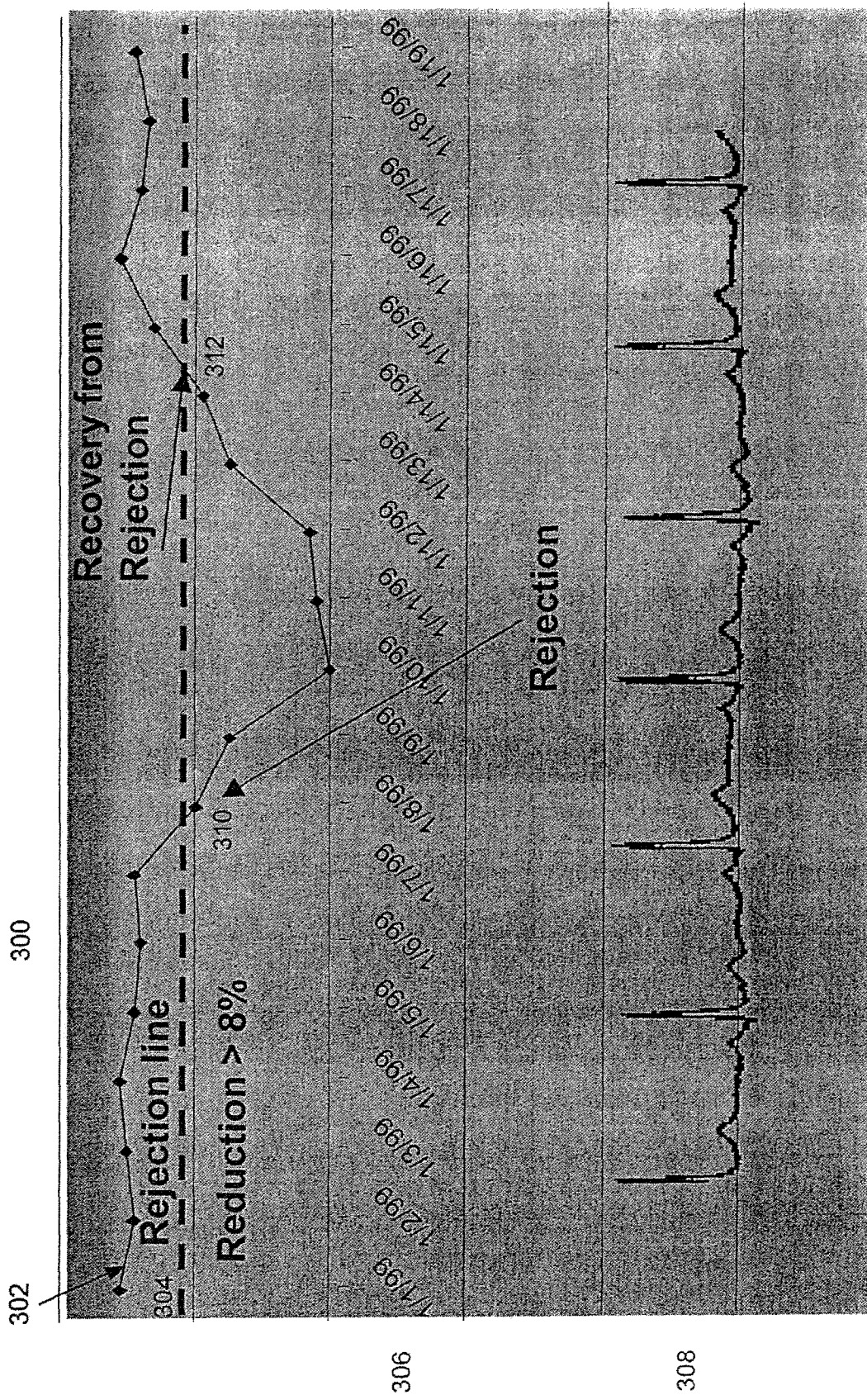

FIG. 4

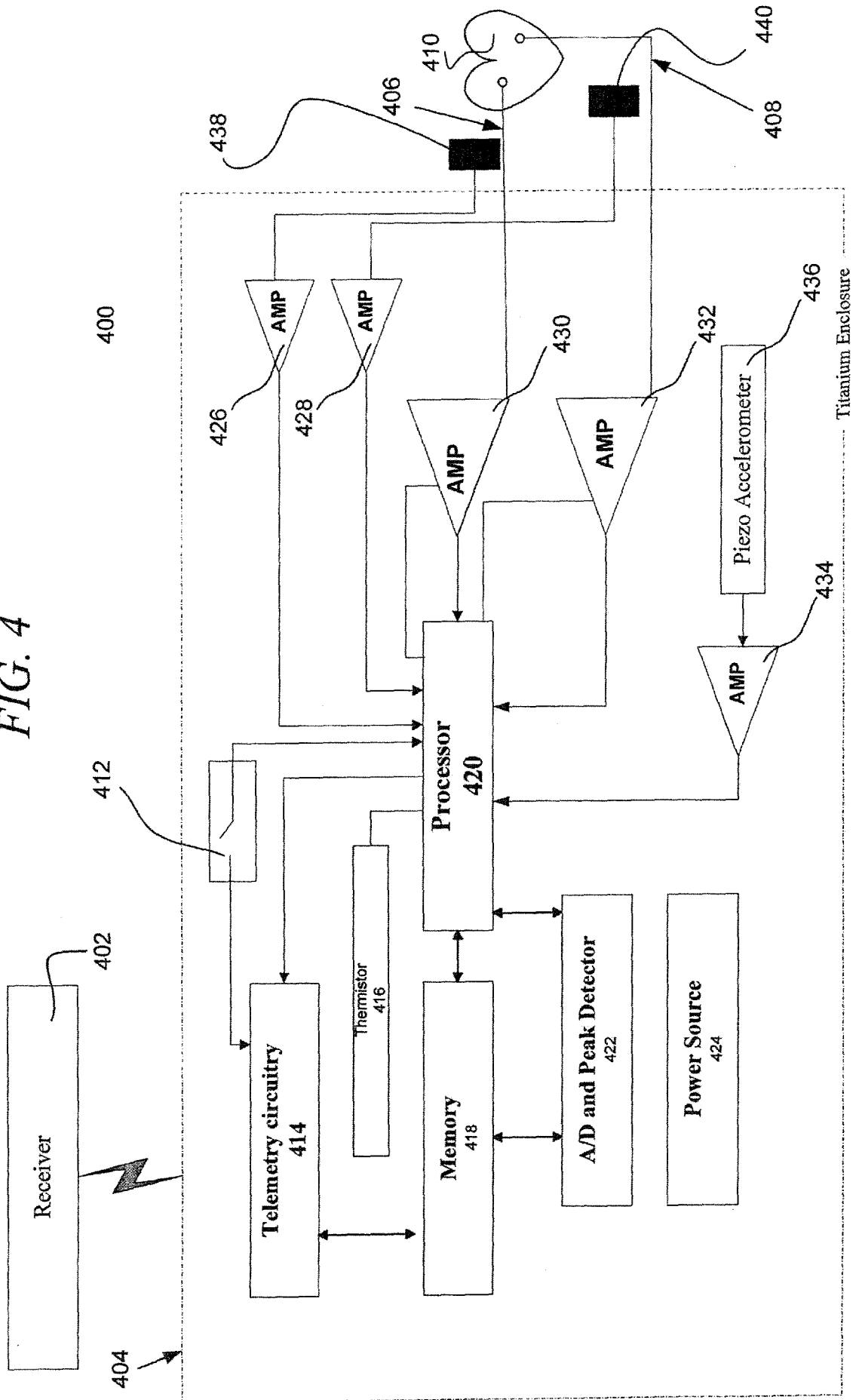

FIG. 5

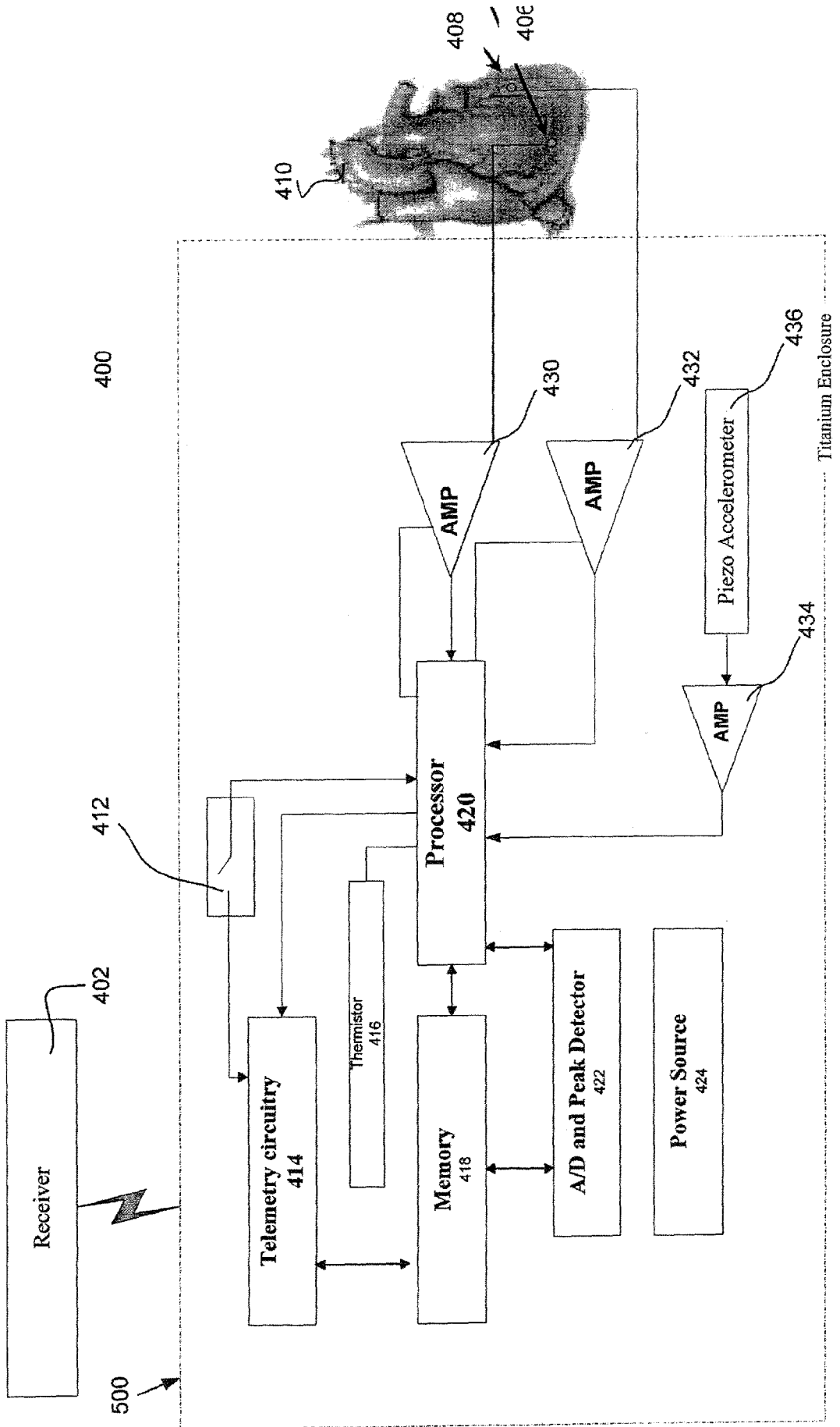
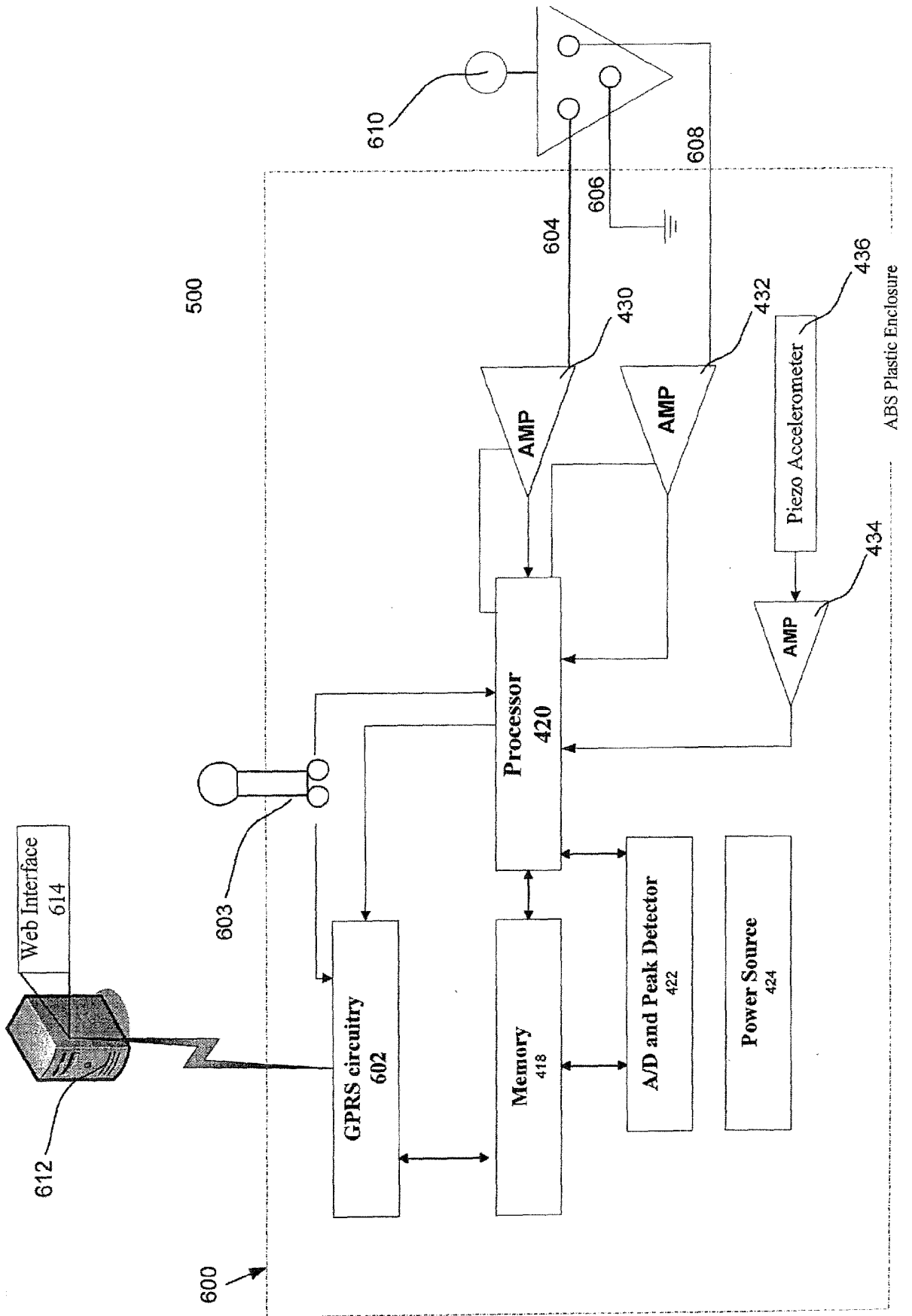

FIG. 6



*FIG. 7*

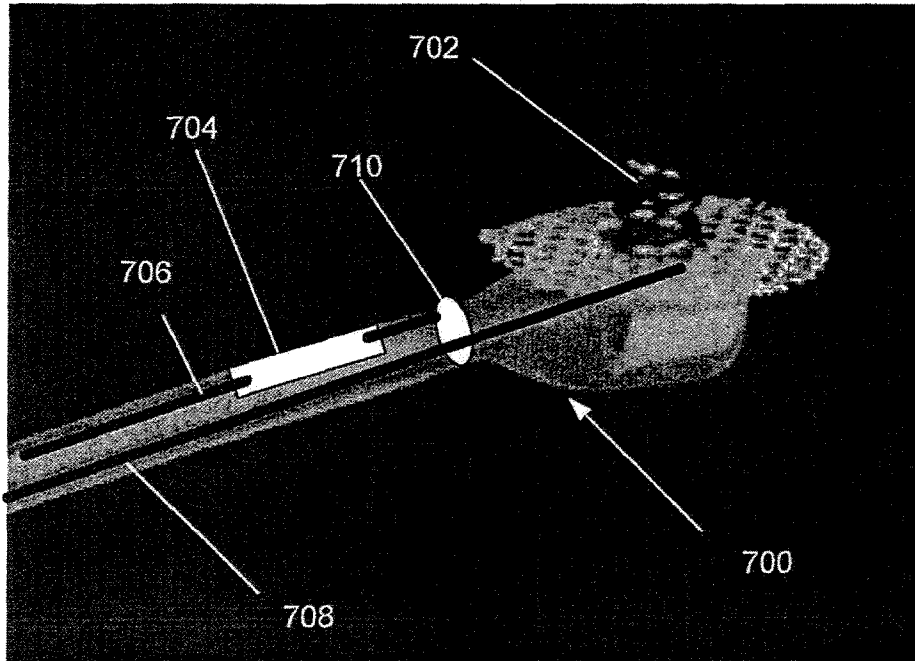

FIG. 8

800

802

IRAM Serial Number 2347  
Patient Number P144

Protocol Readings taken every 5 minutes over two hours @ 10 beats/reading,

807

Date April 4 1999

Electrode lead 1

808  
Average IMEG Amplitude 812  
9.88 mV 814  
Average 816  
IMEG Amplitude (mV) 9.88  
Time (msce) 818  
dV/dt (mV/msec) 820  
Average dV/dt 822  
10.21 mV/msec 824

Minute 5										Minute 10									
1	2	3	4	5	6	7	8	9	10	1	2	3	4	5	6	7	8	9	10
9.9	9.9	9.9	9.7	9.9	9.9	9.9	9.9	9.8	9.8	10.0	9.9	9.9	9.7	9.5	9.9	9.9	9.8	9.8	10.0
9.88										9.84									
9.9	9.9	9.9	9.7	9.9	9.9	9.9	9.9	9.8	9.8	10.0	9.9	9.9	9.7	9.5	9.9	9.9	9.8	9.8	10.0
0.97	0.97	0.97	0.95	0.97	0.97	0.97	0.97	0.96	0.96	0.98	0.97	0.97	0.97	0.95	0.93	0.97	0.97	0.96	0.98
0.2	0.2	0.2	0.2	0.2	0.2	0.2	0.2	0.2	0.2	0.2	0.2	0.2	0.2	0.2	0.2	0.2	0.2	0.2	0.2
10.21										10.21									

○ ○ ○

Electrode lead 2

810  
Average IMEG Amplitude 812  
10.20 mV 814  
Average 816  
IMEG Amplitude (mV) 10.25  
Time (msce) 818  
dV/dt (mV/msec) 820  
Average dV/dt 822  
10.54 mV/msec 824

Minute 5										Minute 10									
1	2	3	4	5	6	7	8	9	10	1	2	3	4	5	6	7	8	9	10
10.2	10.1	10.2	10.1	10.2	10.3	10.1	10.2	10.2	10.1	10.2	10.4	10.2	10.2	10.2	10.1	10.2	10.2	10.6	10.2
10.17										10.25									
10.2	10.1	10.2	10.1	10.2	10.3	10.1	10.2	10.2	10.1	10.2	10.4	10.2	10.2	10.2	10.1	10.2	10.2	10.6	10.2
0.97	0.97	0.97	0.95	0.97	0.94	0.97	0.97	0.96	0.96	0.98	0.97	1.06	0.97	0.95	0.93	0.97	0.97	0.96	0.98
0.5	0.4	0.5	0.6	0.5	1.0	0.4	0.5	0.6	0.3	0.5	0.8	0.5	0.7	1.0	0.4	0.5	0.5	1.0	0.4
10.54										10.54									

○ ○ ○

FIG. 9

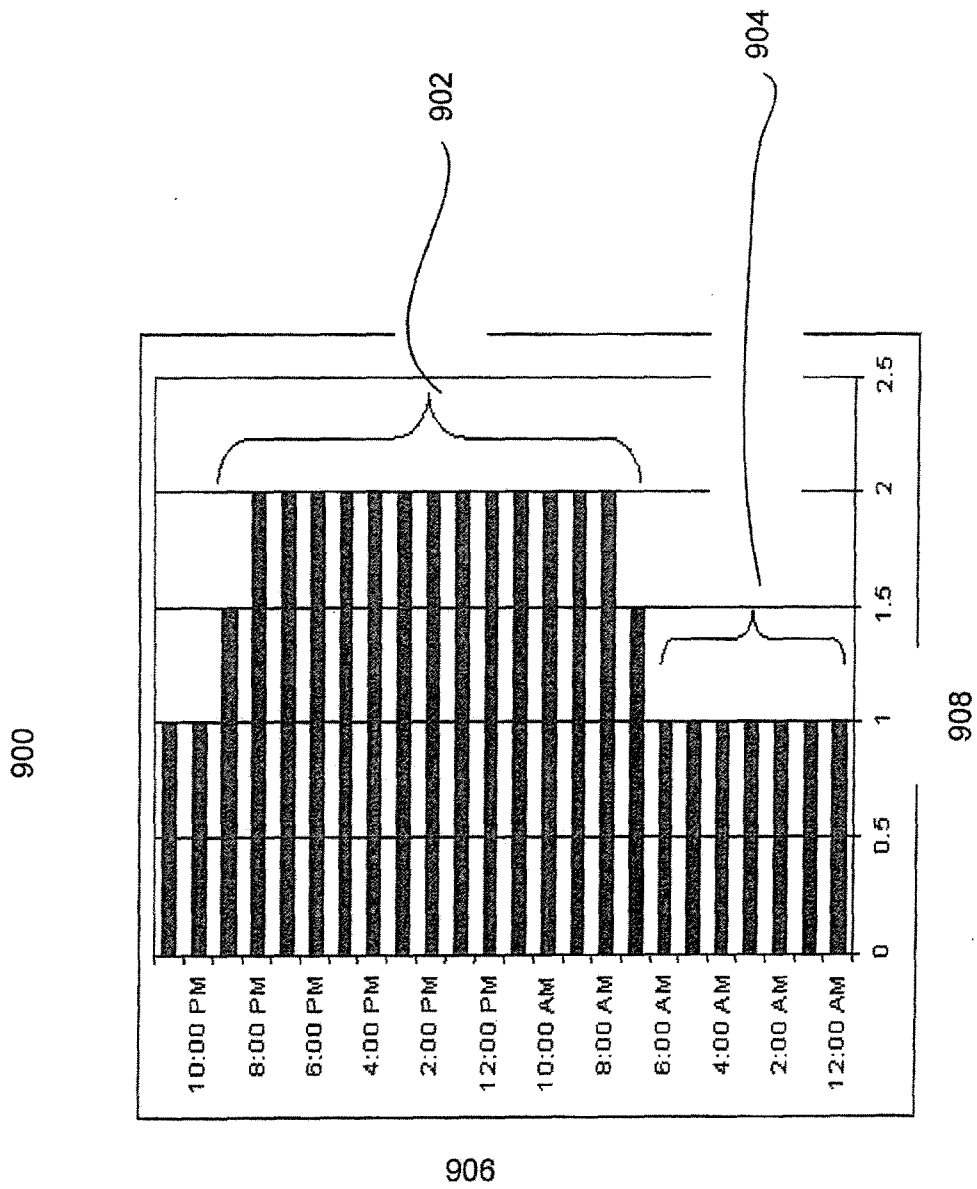

FIG. 10

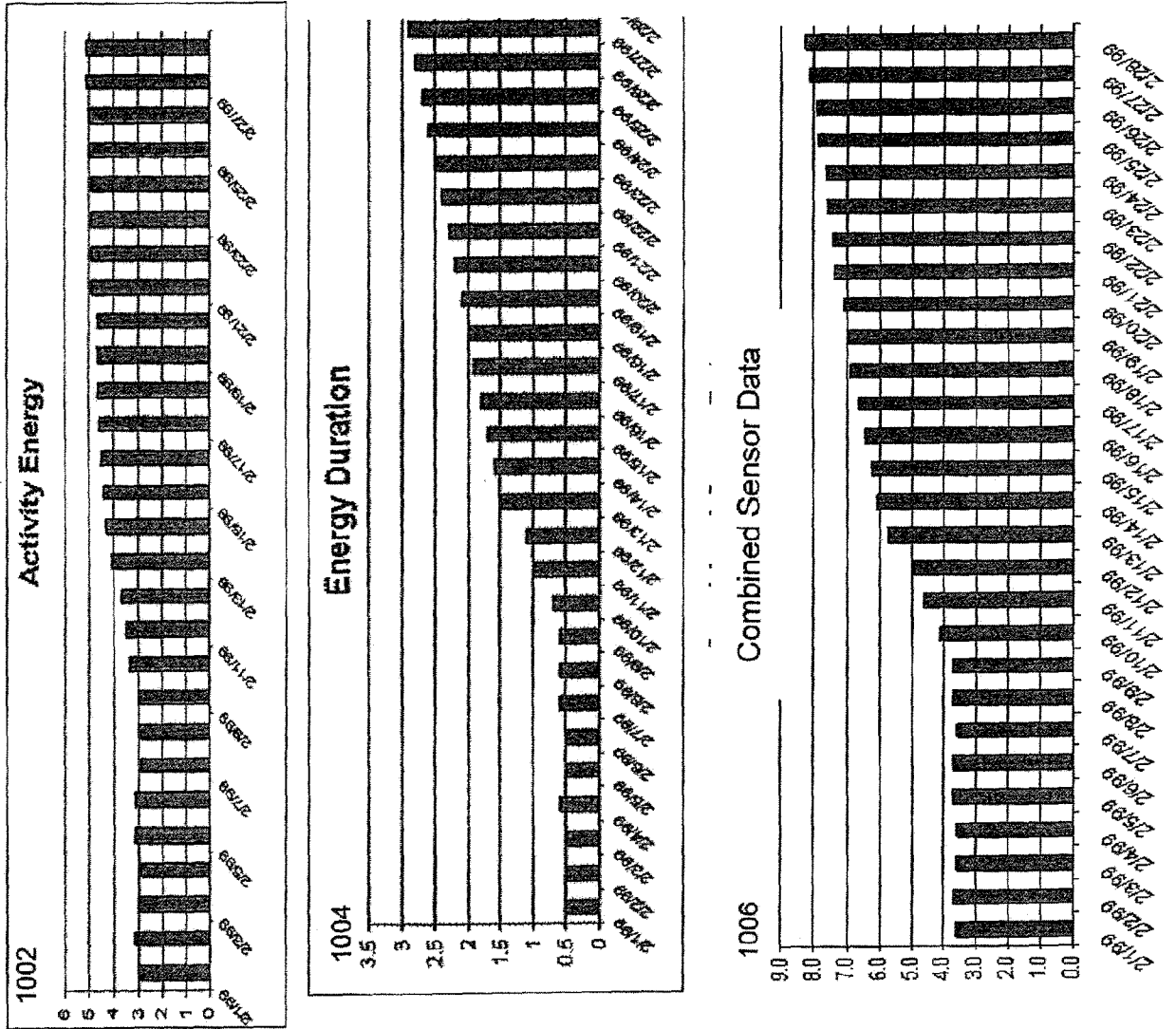
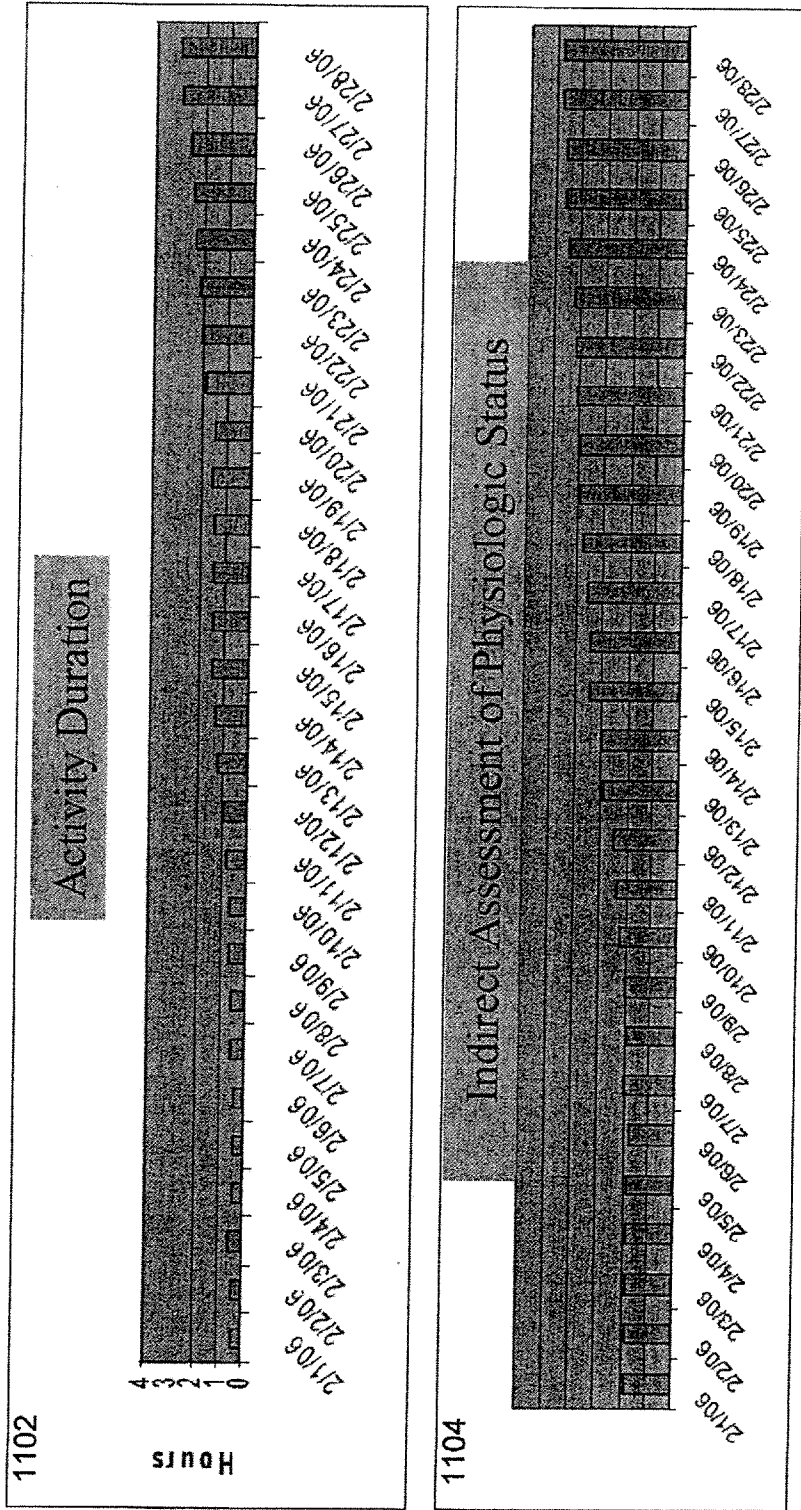

FIG. 11



1106

Combined Sensor	1-Feb	2-Feb	3-Feb	4-Feb	5-Feb	6-Feb	7-Feb	8-Feb	9-Feb	10-Feb	11-Feb	12-Feb
Reciprocal of Sleep	0.1	0.099	0.1	0.098	0.099	0.1	0.104	0.099	0.1	0.1111	0.1235	0.125
Exercise level	3	3	3	3	3	3	3.2	3.1	3.1	3.6	3.7	3.9
Duration of Exercise	0.5	0.5	0.6	0.5	0.5	0.4	0.6	0.6	0.7	0.7	0.8	1
<b>TOTAL</b>	<b>3.60</b>	<b>3.60</b>	<b>3.70</b>	<b>3.60</b>	<b>3.60</b>	<b>3.50</b>	<b>3.90</b>	<b>3.80</b>	<b>3.90</b>	<b>4.41</b>	<b>4.62</b>	<b>5.03</b>

FIG. 12

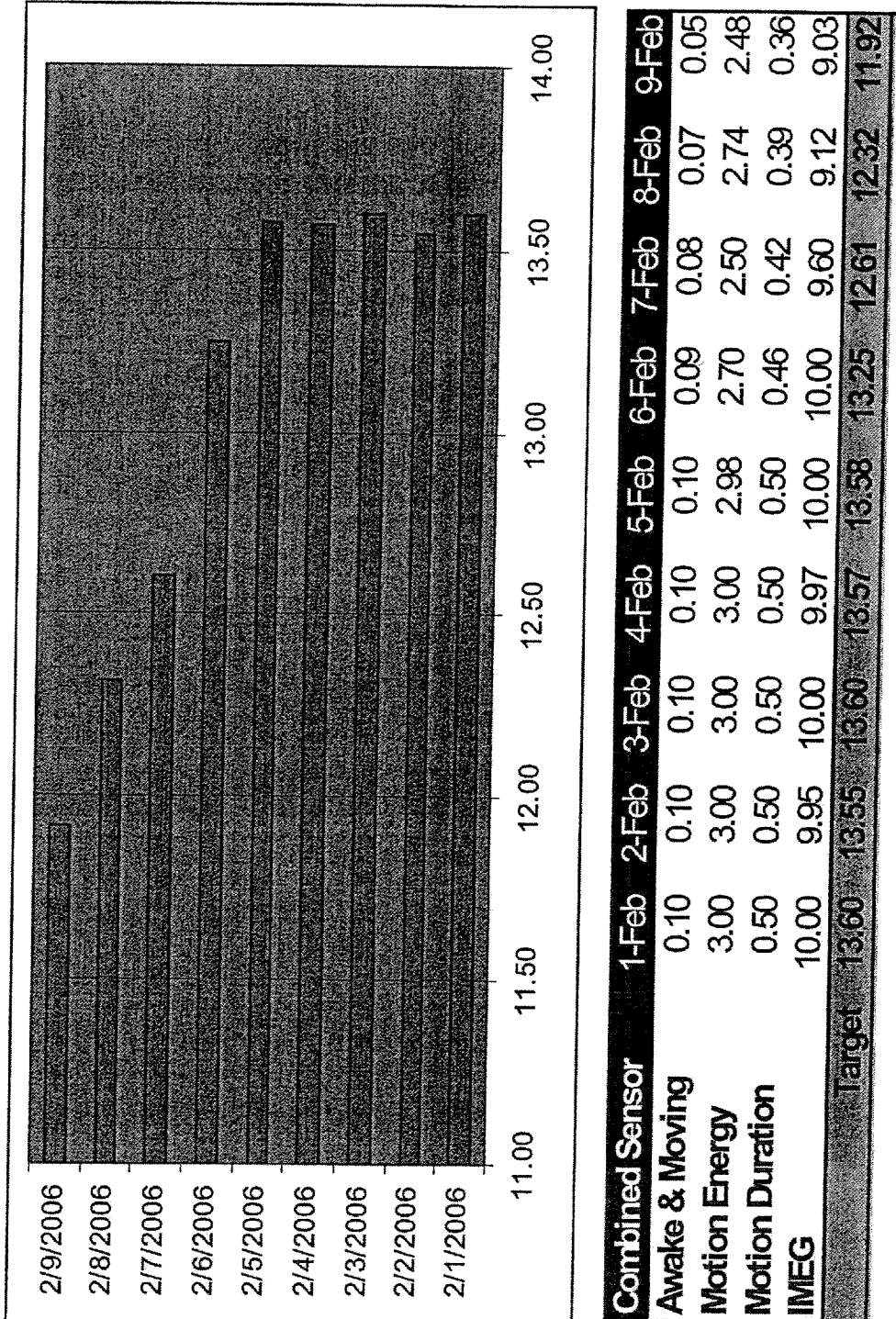

1202

Combined Sensor	1-Feb	2-Feb	3-Feb	4-Feb	5-Feb	6-Feb	7-Feb	8-Feb	9-Feb
Awake & Moving	0.10	0.10	0.10	0.10	0.10	0.09	0.08	0.07	0.05
Motion Energy	3.00	3.00	3.00	3.00	2.98	2.70	2.50	2.74	2.48
Motion Duration	0.50	0.50	0.50	0.50	0.50	0.46	0.42	0.39	0.36
IMEG	10.00	9.95	10.00	9.97	10.00	10.00	9.60	9.12	9.03
Target	13.60	13.55	13.60	13.57	13.58	13.25	12.61	12.32	11.92

1204

FIG. 13

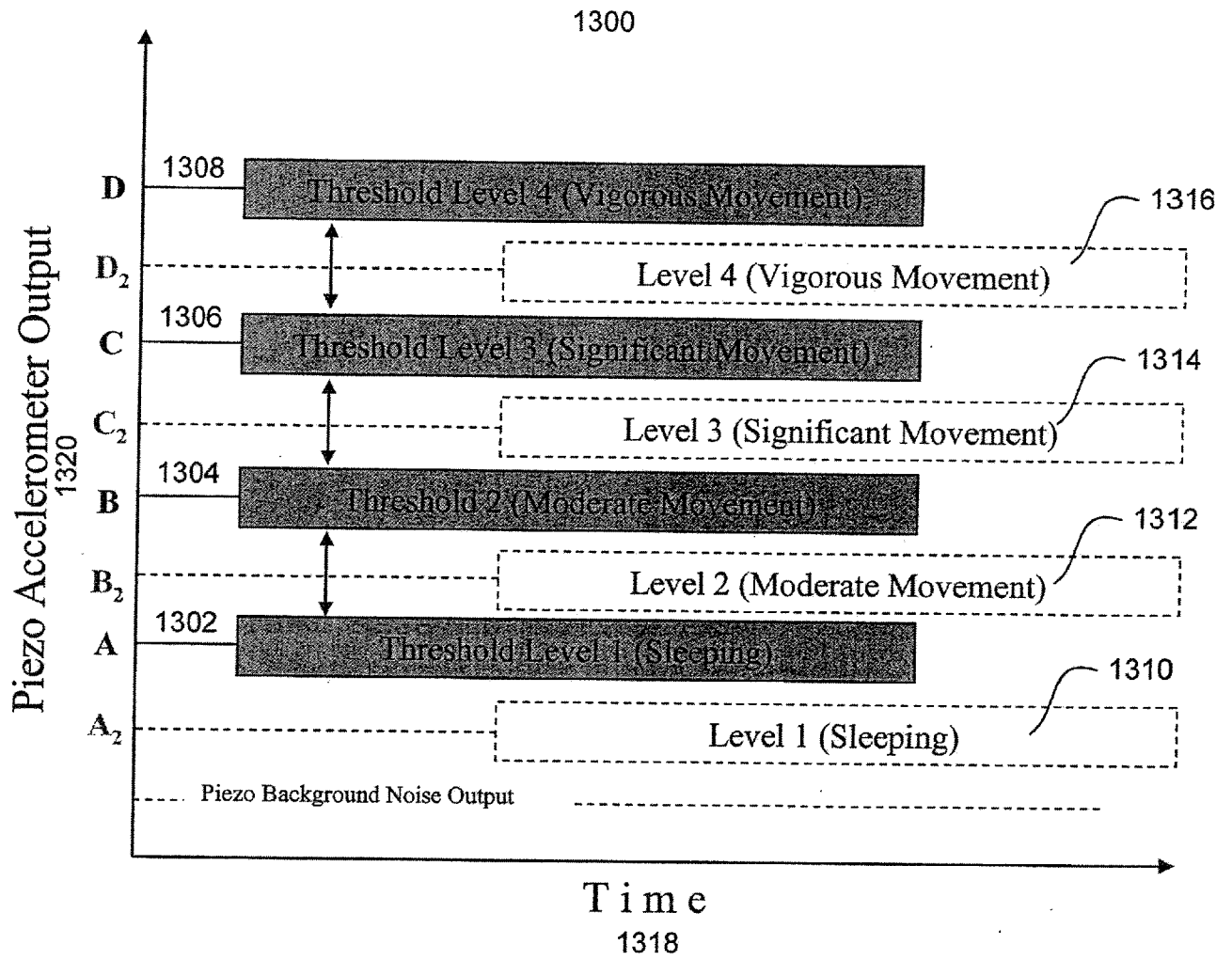

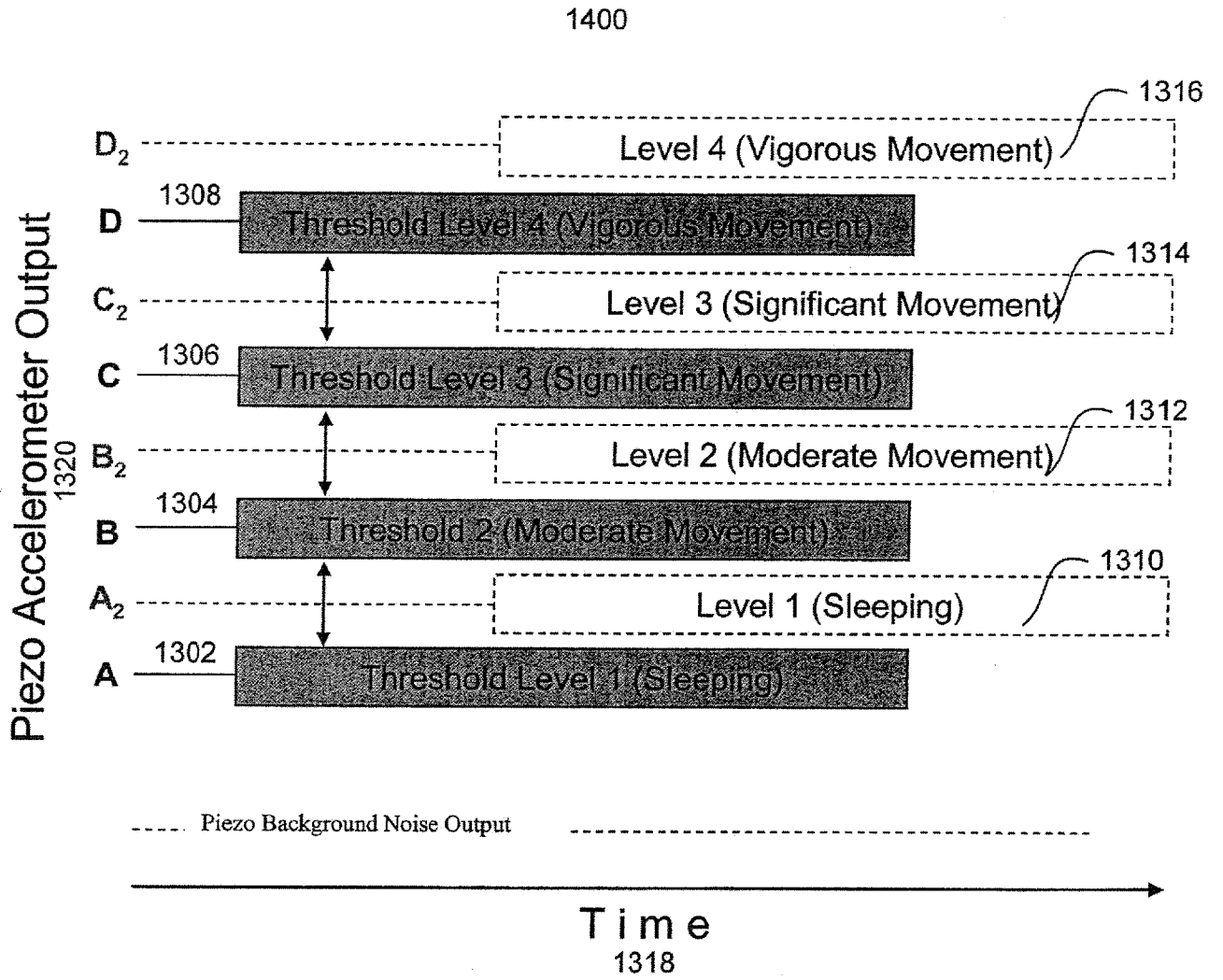

*FIG. 15*

Implantation

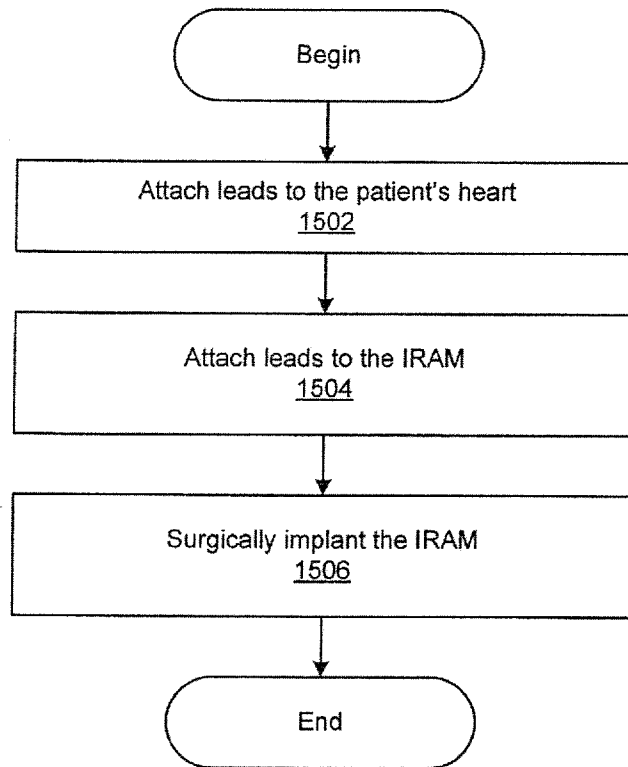

FIG. 16

Sleep monitoring

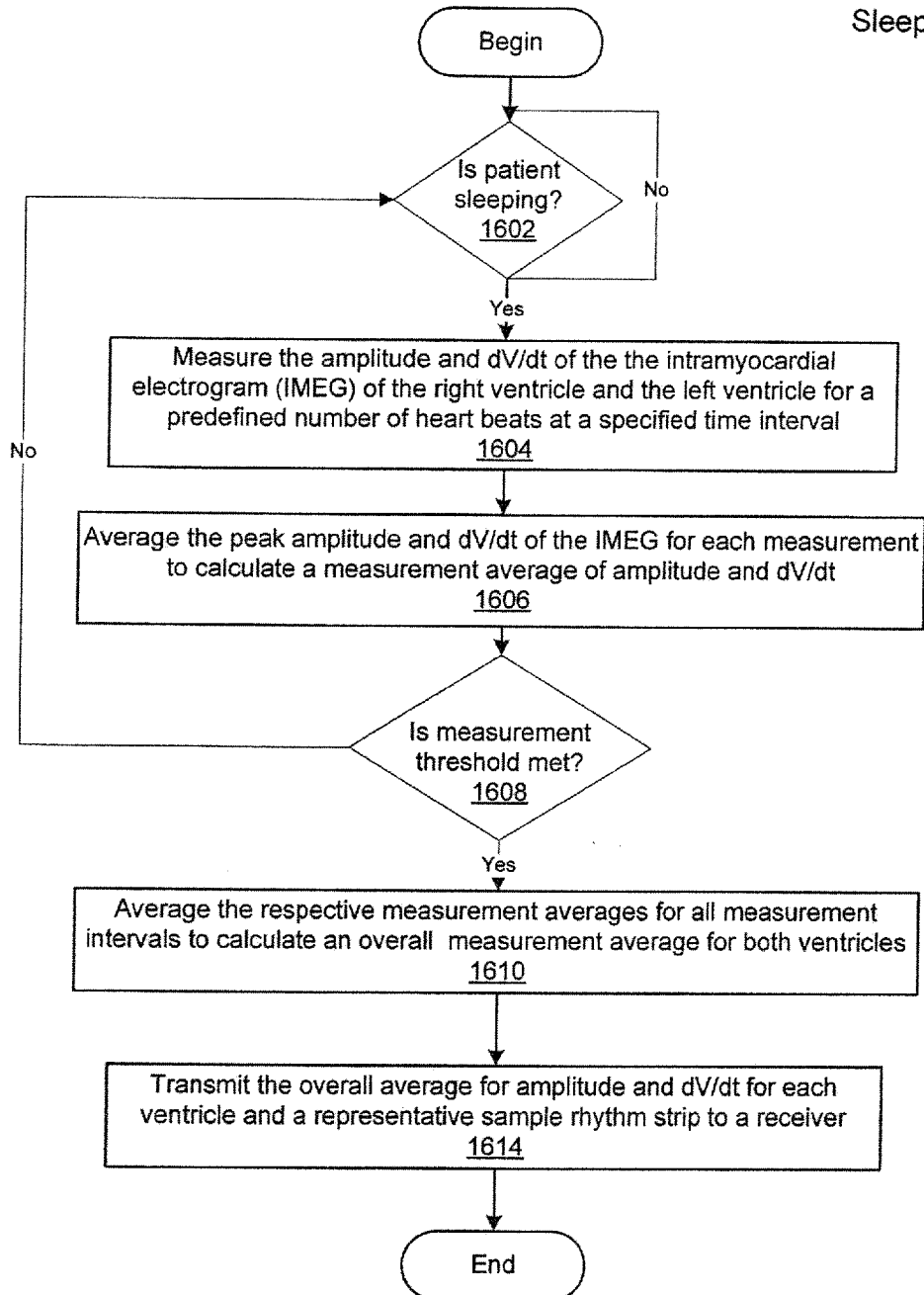

FIG. 17

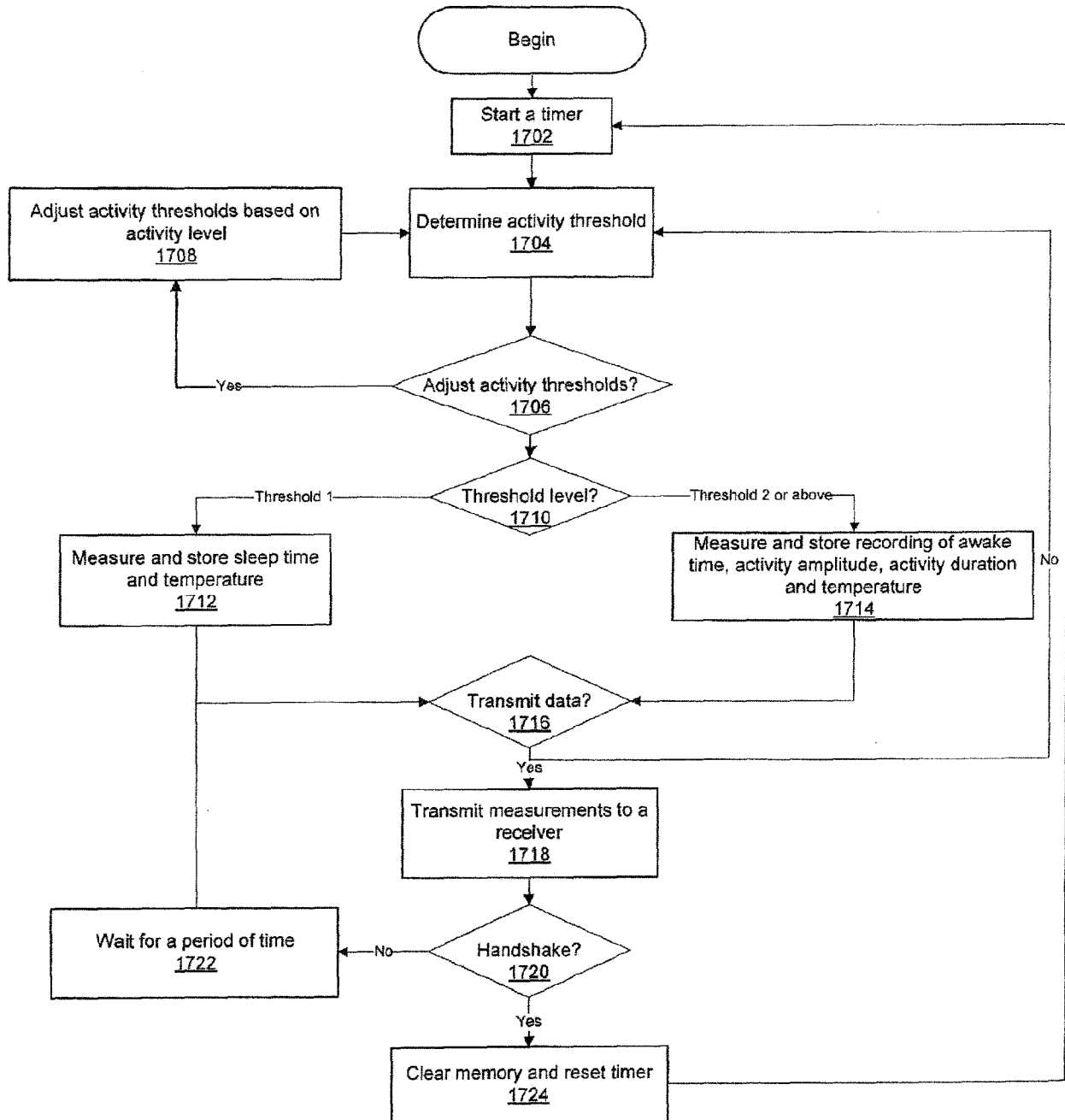

FIG. 18

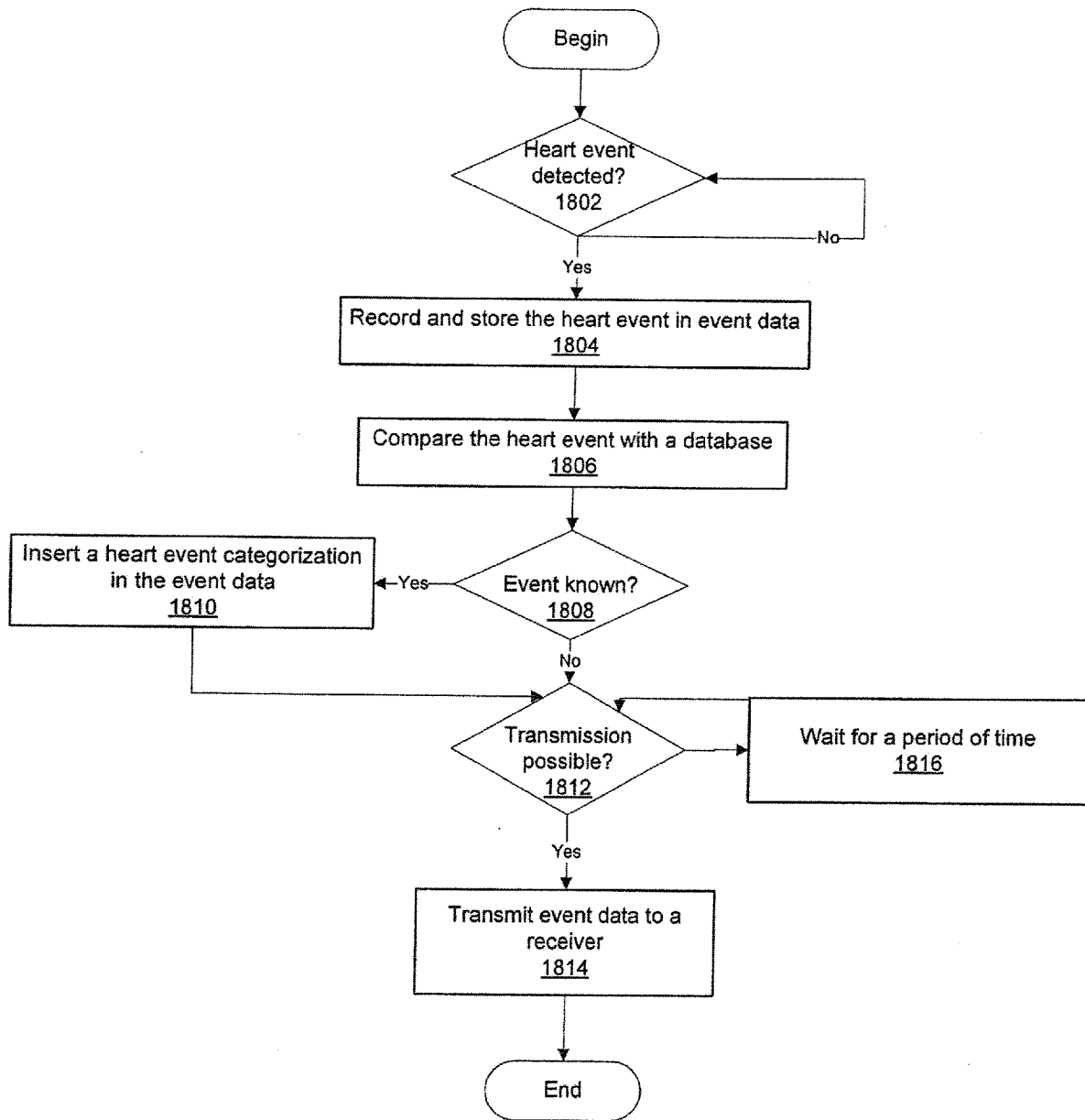

FIG. 19

1900

Doctors Demographics    Patient Listing    New Patient Enrollment    Set Parameters    Billing

1902		1906		1908	
Veterans Administration Hospital		To Change Password		ENTER CURRENT PASSWORD	
J Fred Muggs		New Password		None	
Ralph McDougal, MD		Enter New Password		None	
22 New Hampshire Street		Verify New Password		None	
Washington, DC 02111		Verify Old Password		None	
(301) 777-2257		Verify New Password		None	
(301) 777-2200		Verify Old Password		None	



FIG. 21

2100

Doctors Demographics	Patient Listing	New Patient Enrollment	Set Parameters	Billing
Patient Name		NEW PATIENT ENROLLMENT	Work	
Primary Address		Primary Address	Address	
City/State/Zip		City/State/Zip	City/State/Zip	
Telephone		Telephone	Telephone	
Physic Model		Send Number	Patient # (Auto fill)	55975-07
Referring Physician Name		Telephone	Fax	
Address		City/State/Zip		
Next of Kin Name		Home Telephone	Work Telephone	
		Send to Primary		

FIG. 22

2200

Doctors Demographics

Patient Listing

New Patient Enrollment

Set Parameters

Billing

Patient Information			
Name	Street Address	City	State
Seymour hair	1414 Balding Dr	Newark	NJ
Home Tel	CellPhone	Work Phone	Device Model
201-555-5399	Same	U81-U812	QRS 1
			Serial Num
			123456

Monitoring Criteria			
Item	<	>	Awake During Exercise
Rate	50	100	Both No
PR	80	200	Both Yes
QRS	100	140	Both Yes
QT	110	400	Both Yes
PVC/mm	N/A	5	S Yes
PVC/mm	N/A	10	A Yes
More PVC	Yes	No	Awake Sleep
Multiform PVC	Yes		Both Yes
Bigeminy	Yes		Both Yes
Trigeminy	Yes		Both Yes

Friday February 2 2010

FIG. 23

# Event

2300

Patient	Seymour Hair	1414 Balding Dr	Newark, NJ 07024
Event Date	2/2/2007 20:03	Home Phone	Work/Cell Phone
Monitor Type Q1	Serial# 123456	201-555-5399	Same

<b>PRESENT TRANSMISSION</b>			
Symptoms	Irregular Heartbeat		
Measurements	Rate 87-100 BPM	PR 120 msec	QRS 90 msec QT 350 msec
Findings	NSR, SV Ectopy Noted, Multiform PVCs, Pairs, Bigeminy		

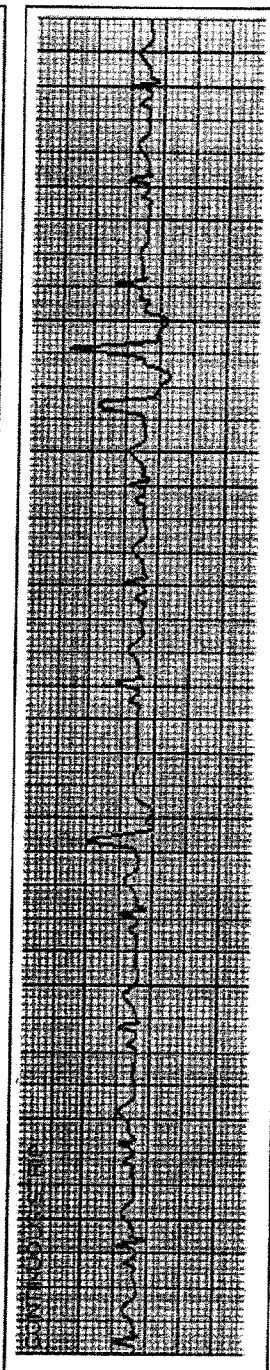
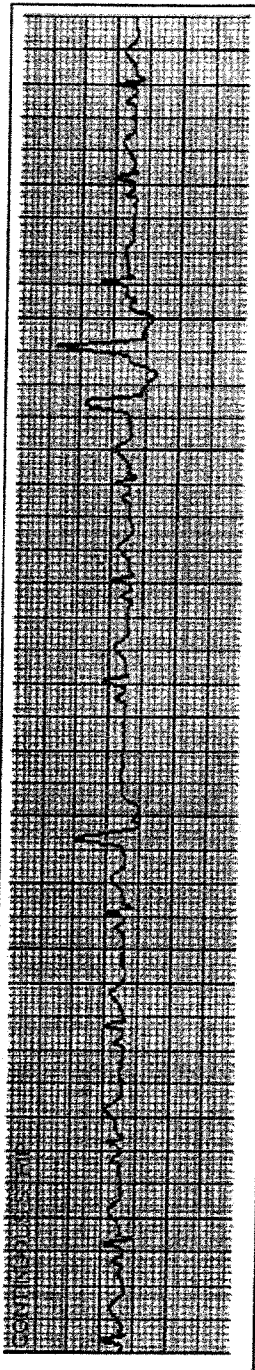

24/40  
FIG. 24

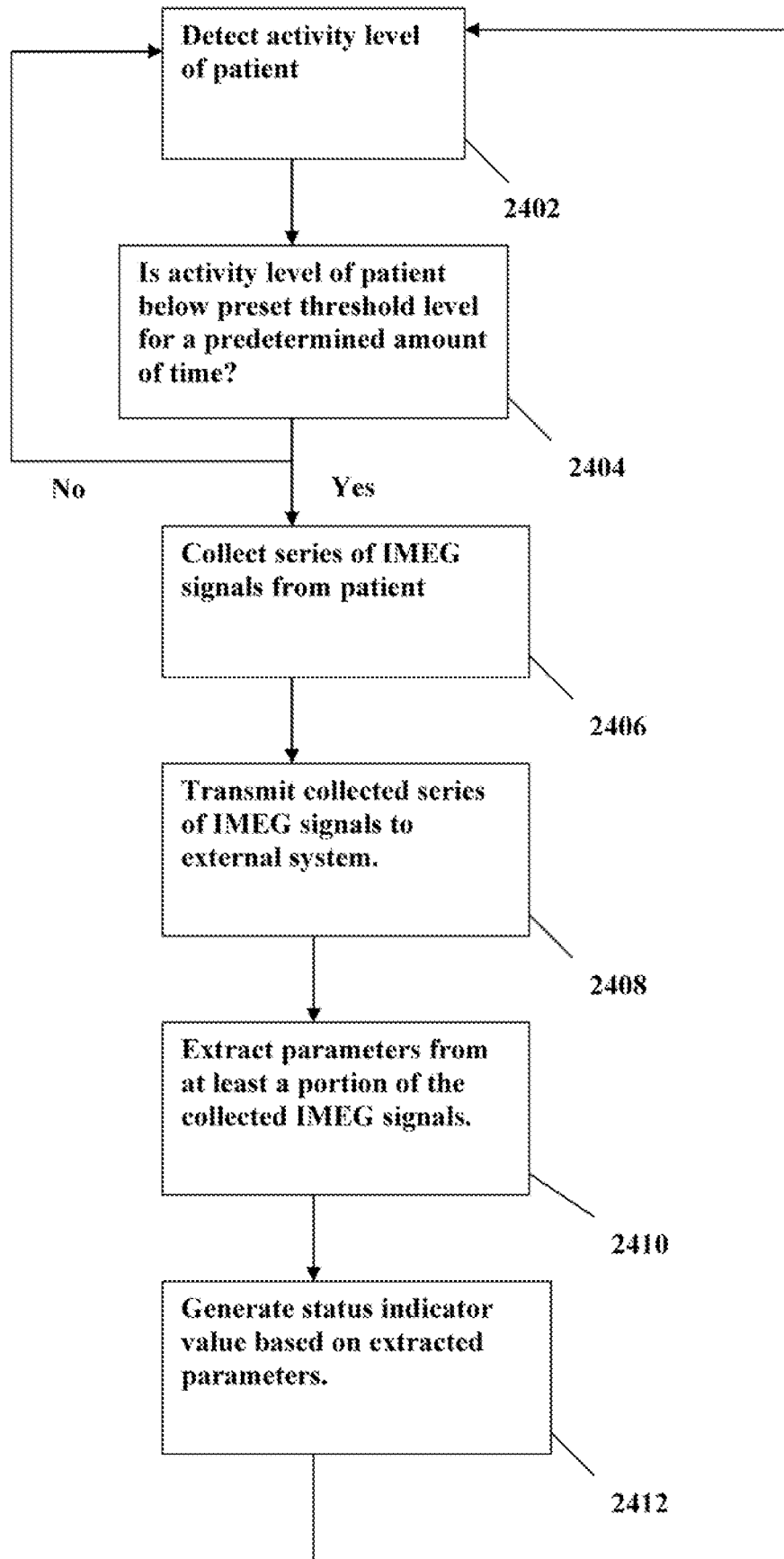

FIG. 25A

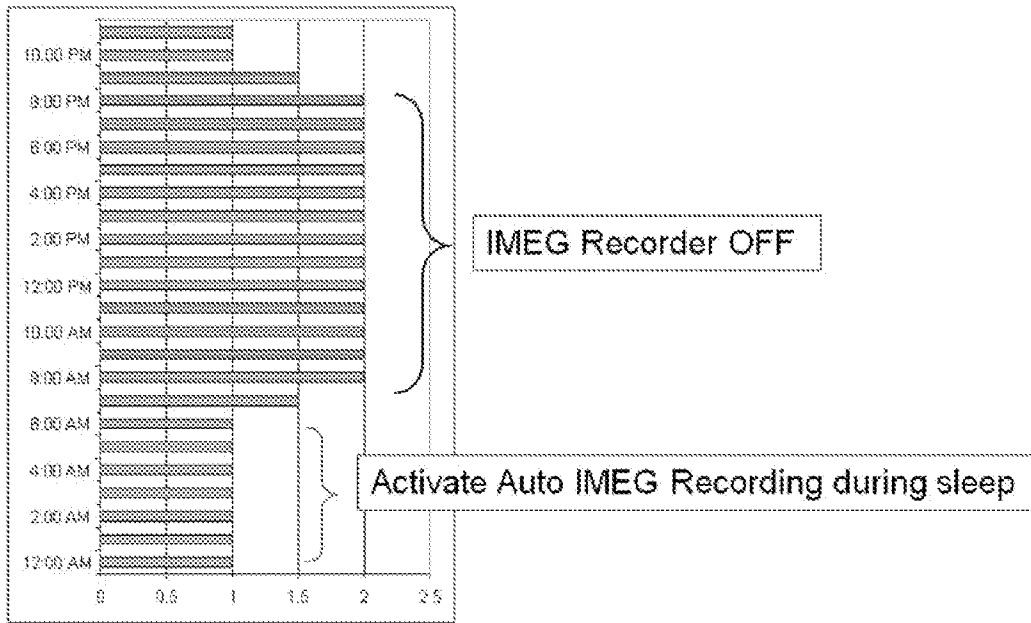

FIG. 25B

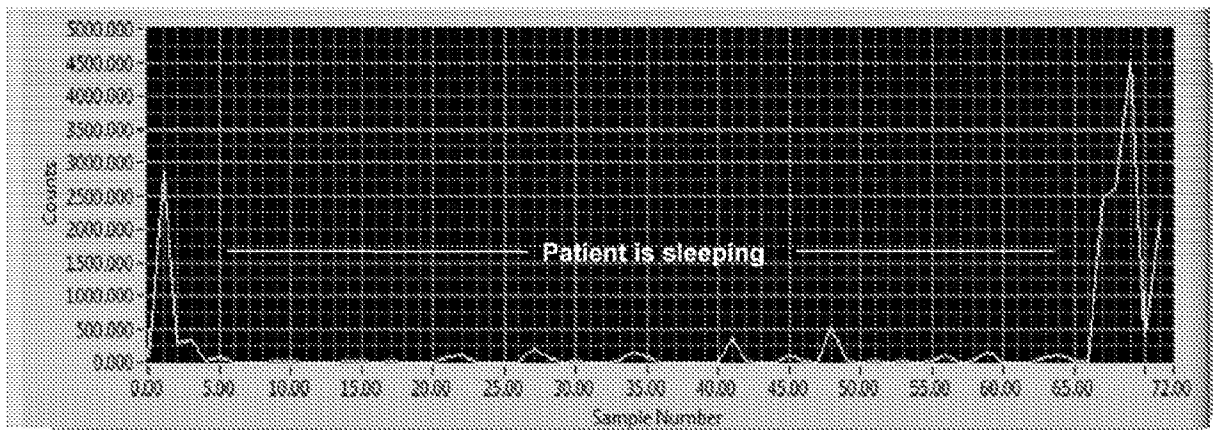

FIG. 26A

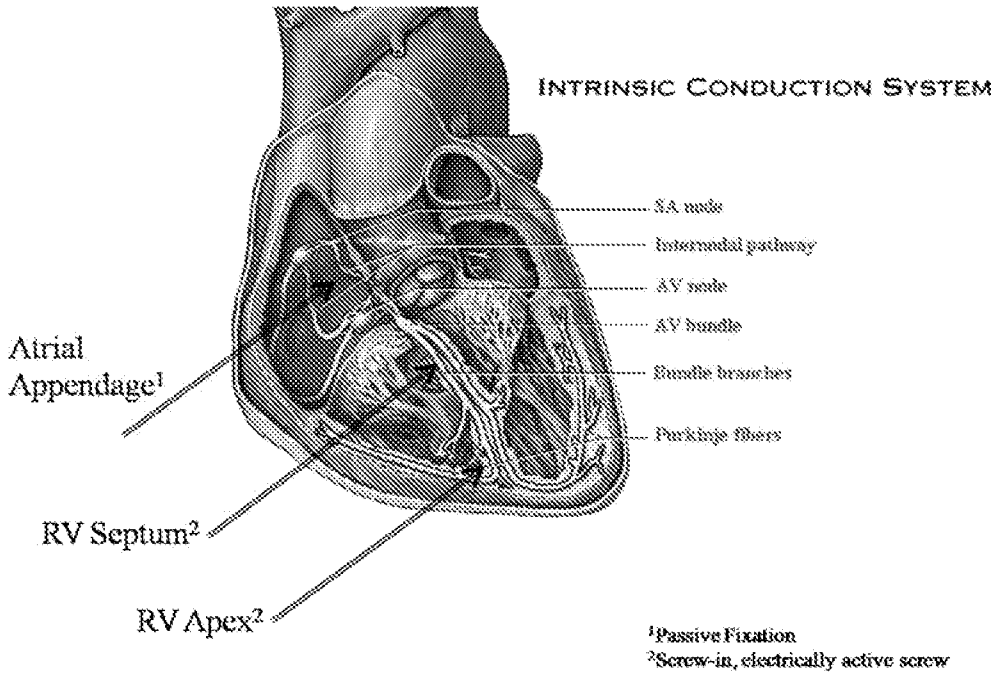

FIG. 26B

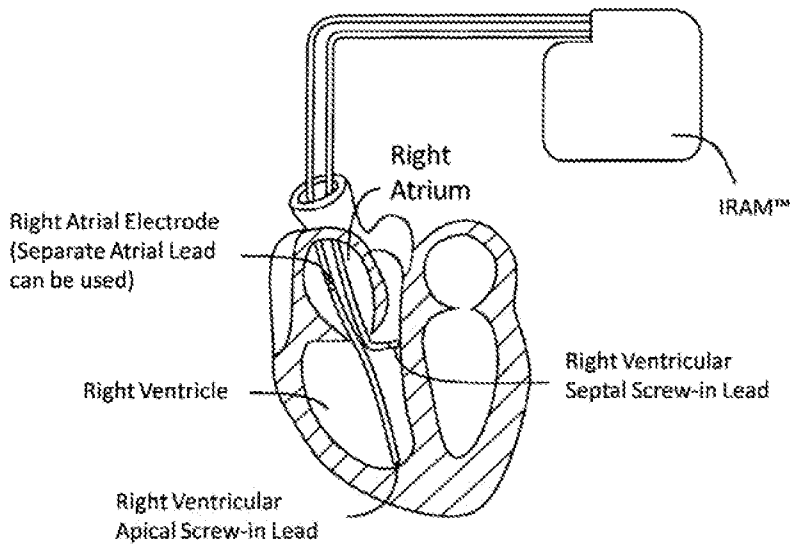

FIG. 26C

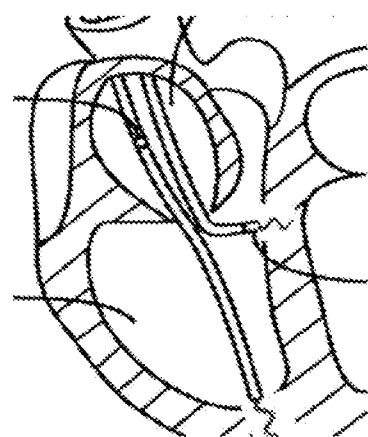

FIG. 27A

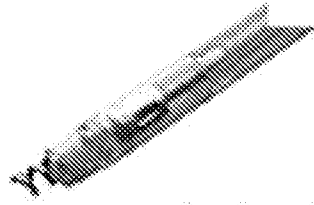

FIG. 27B

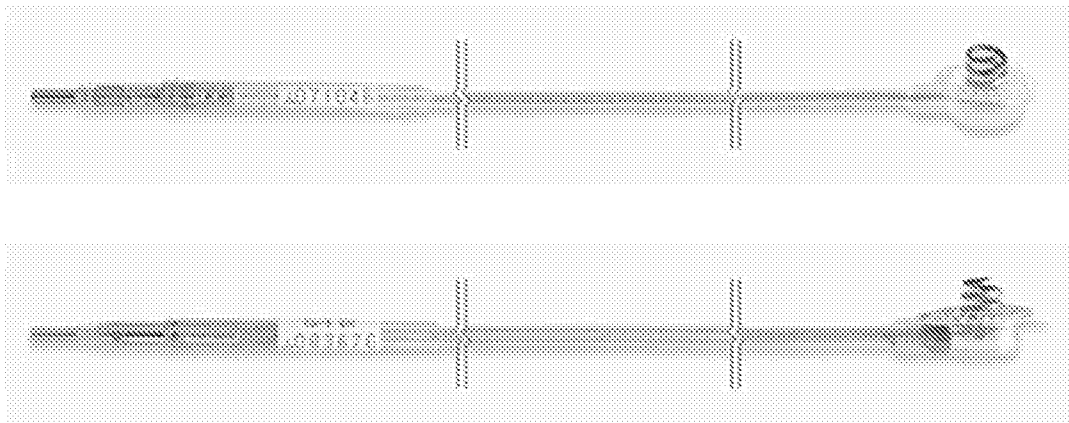

FIG. 28

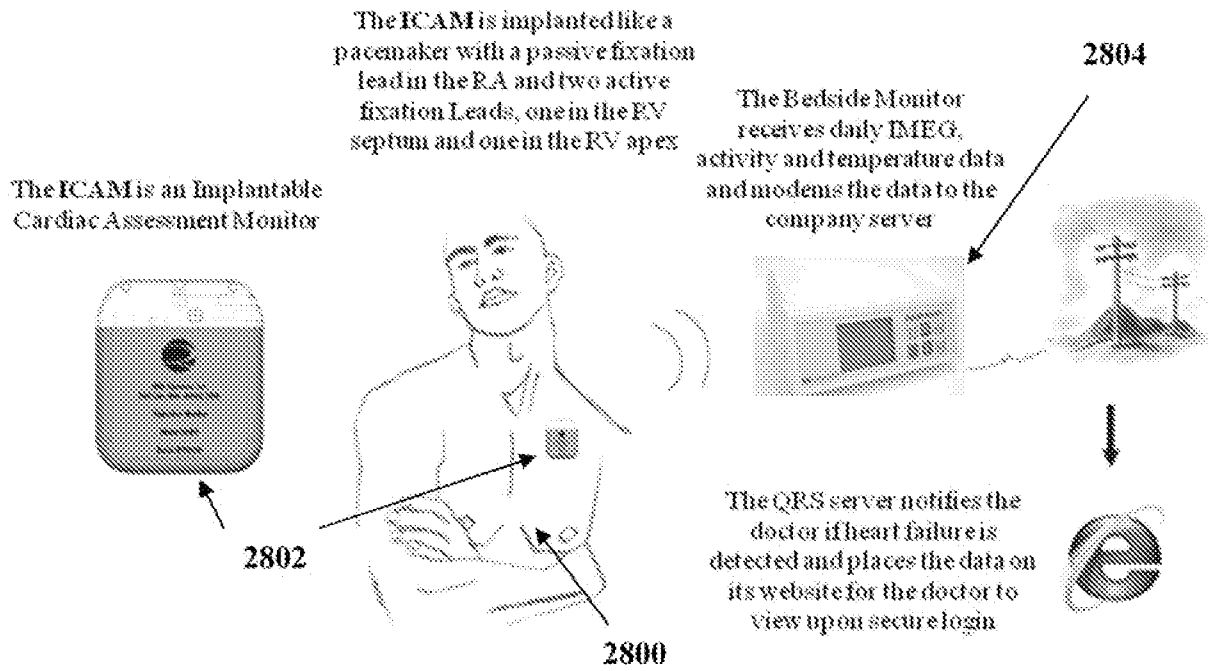

FIG. 29

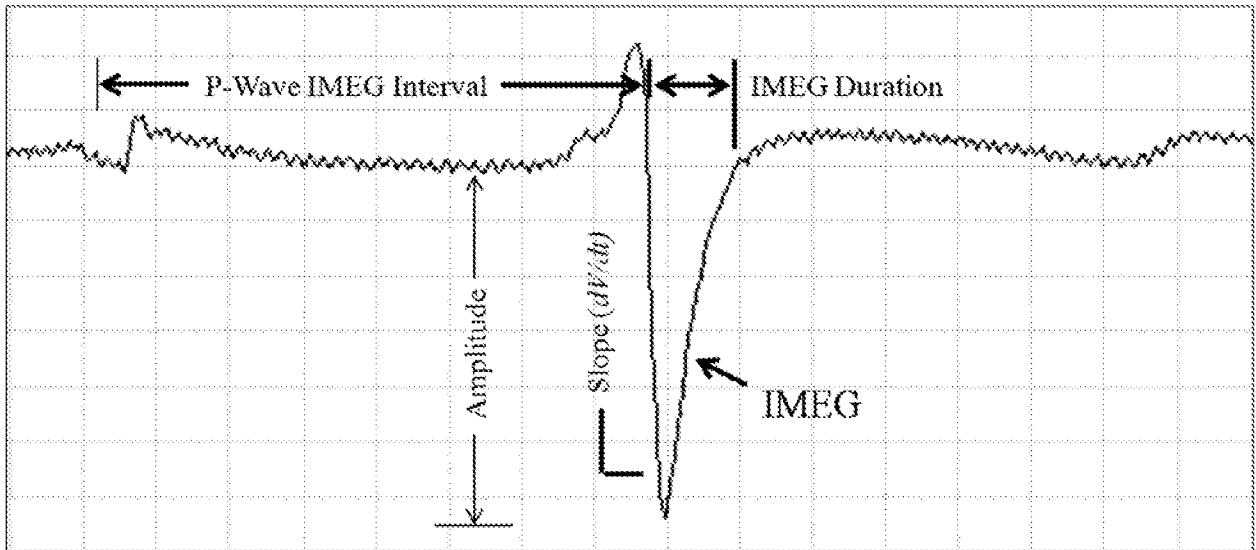

FIG. 30A

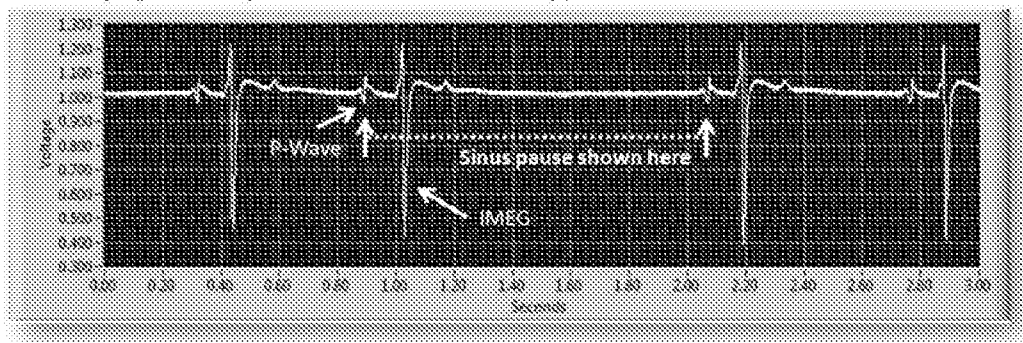

FIG. 30B

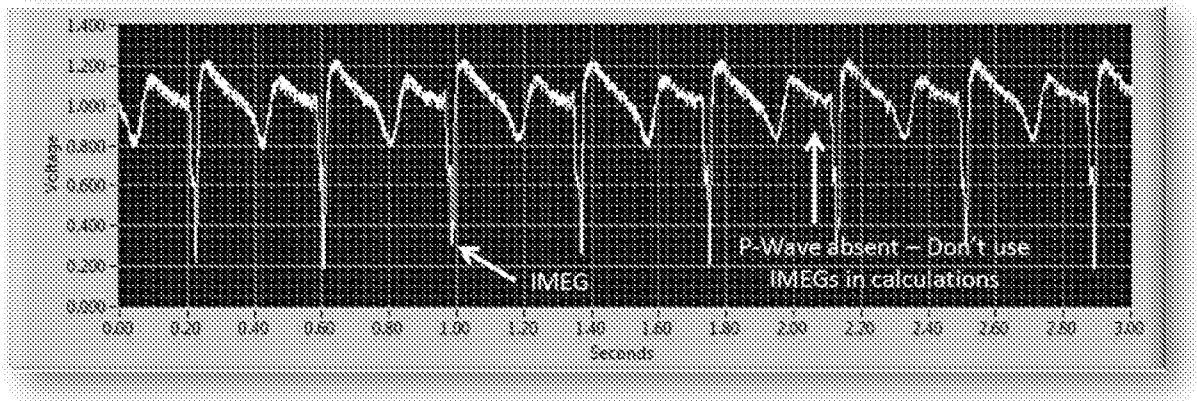

FIG. 31A

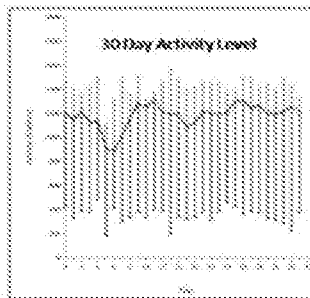

FIG. 31B

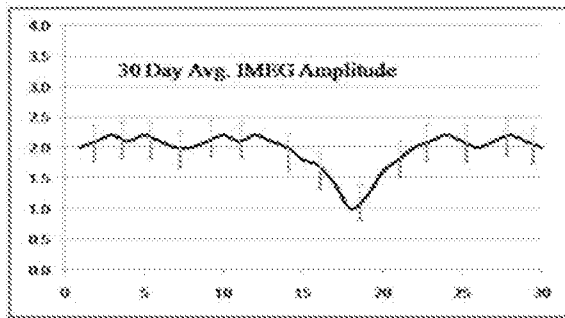
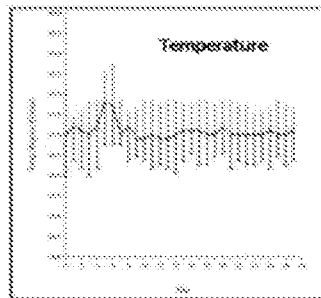

FIG. 31C

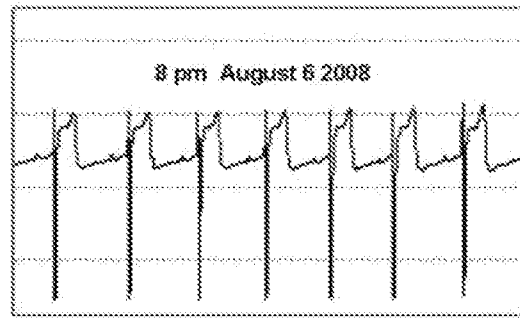

FIG. 31D

FIG. 32A

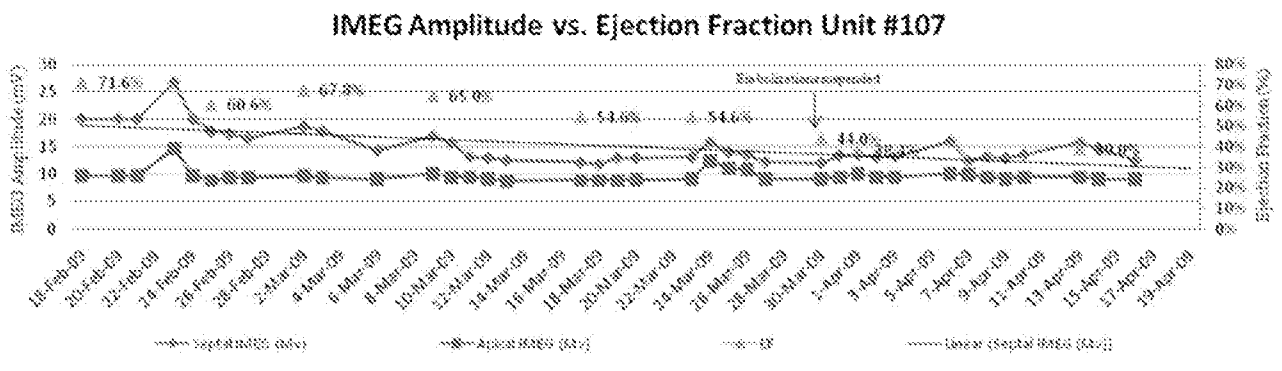

FIG. 32B

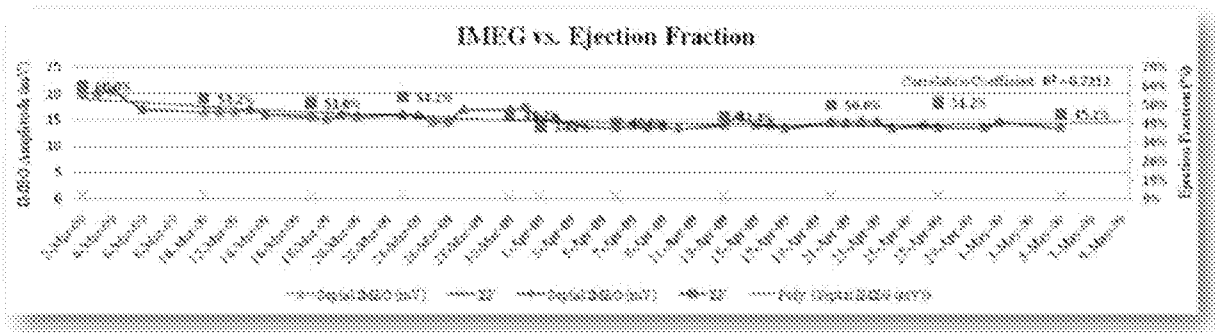

FIG. 33

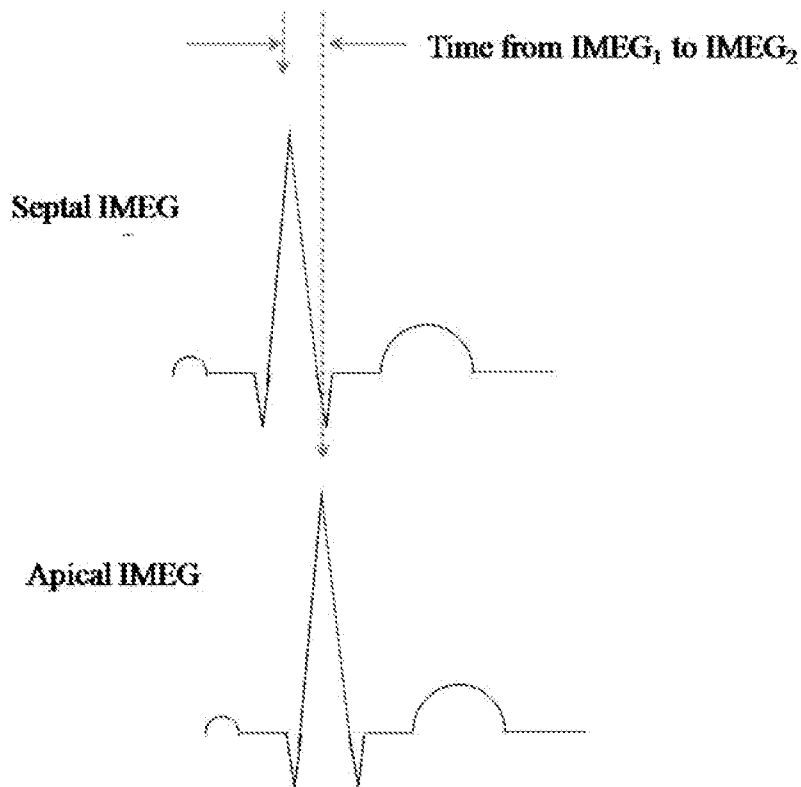
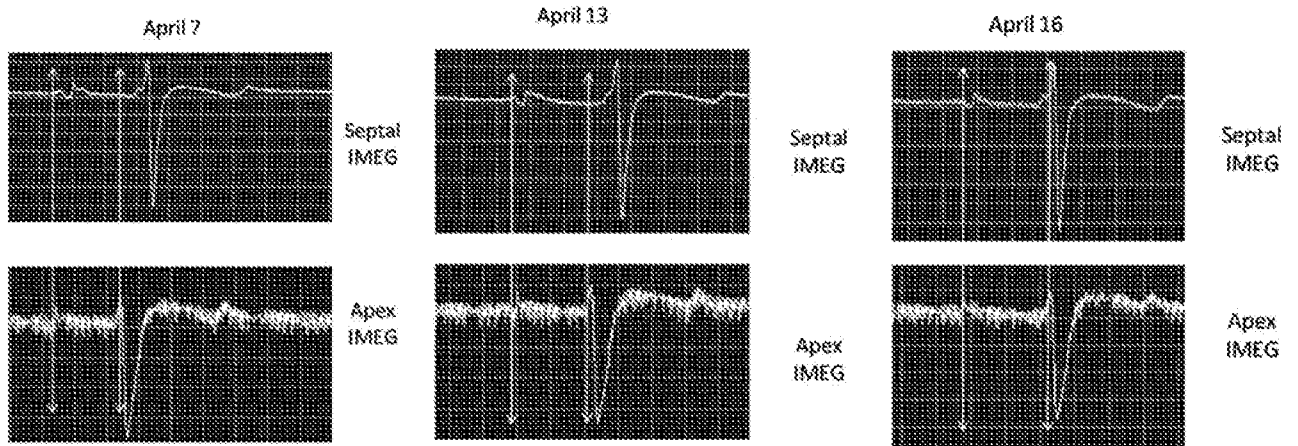

FIG. 34



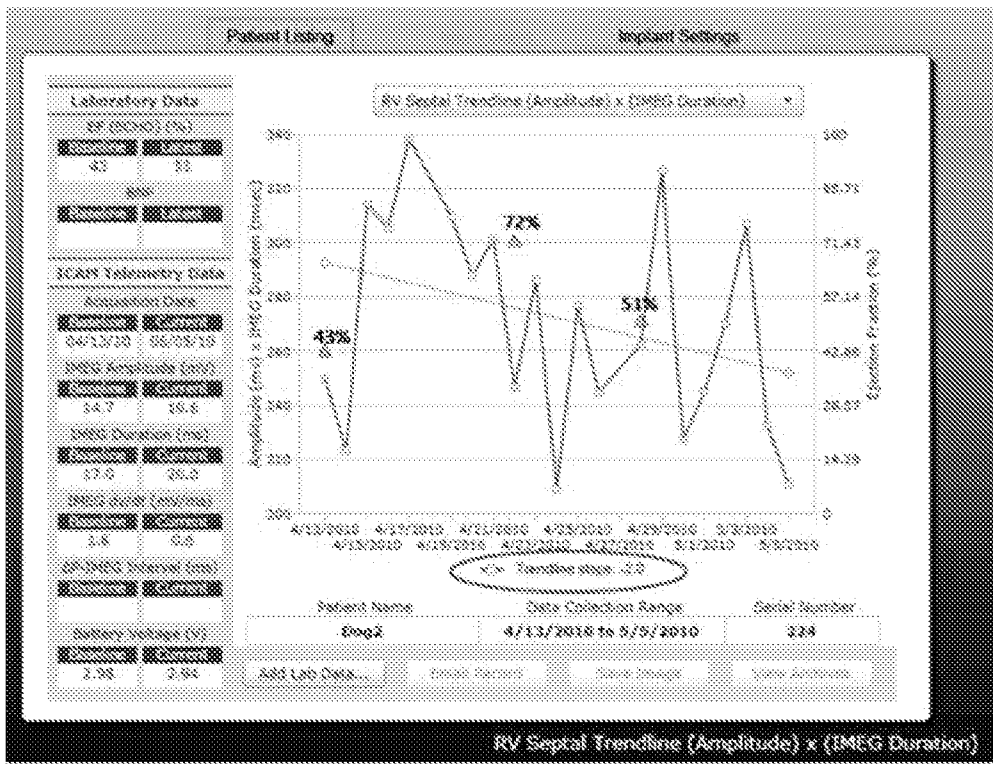

FIG. 35A

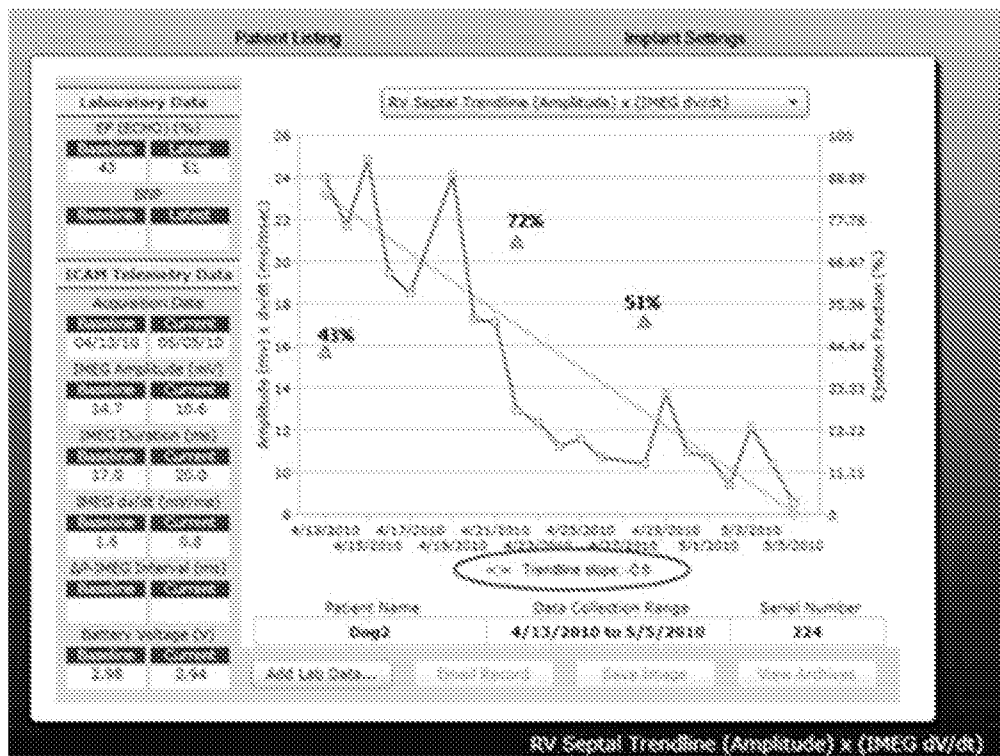

FIG. 35B



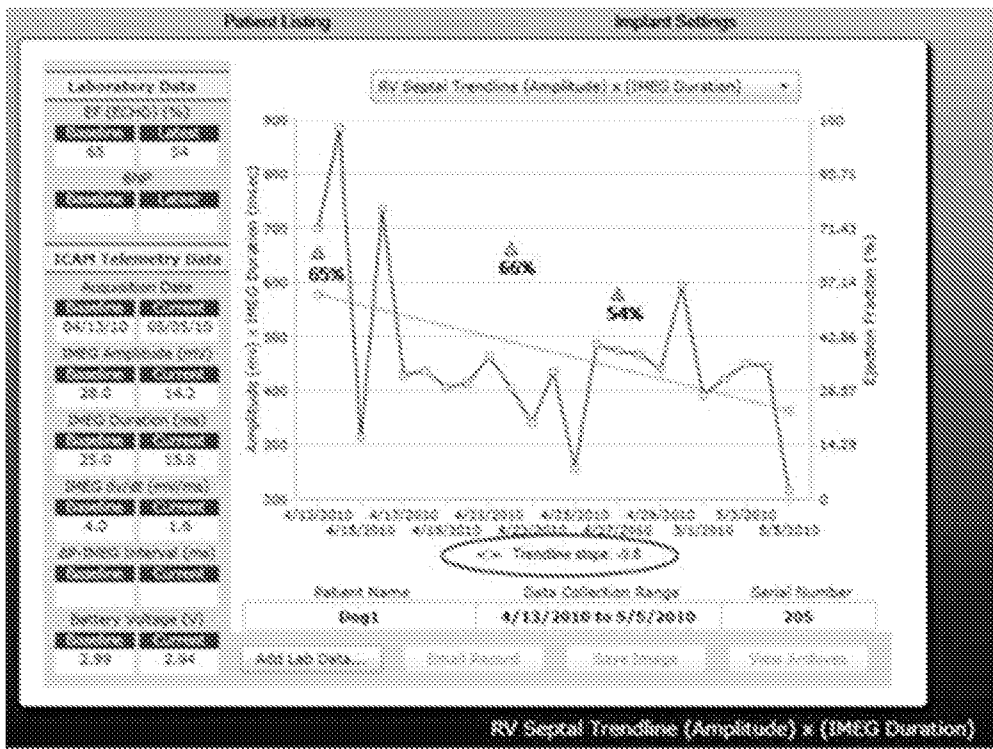

FIG. 36A

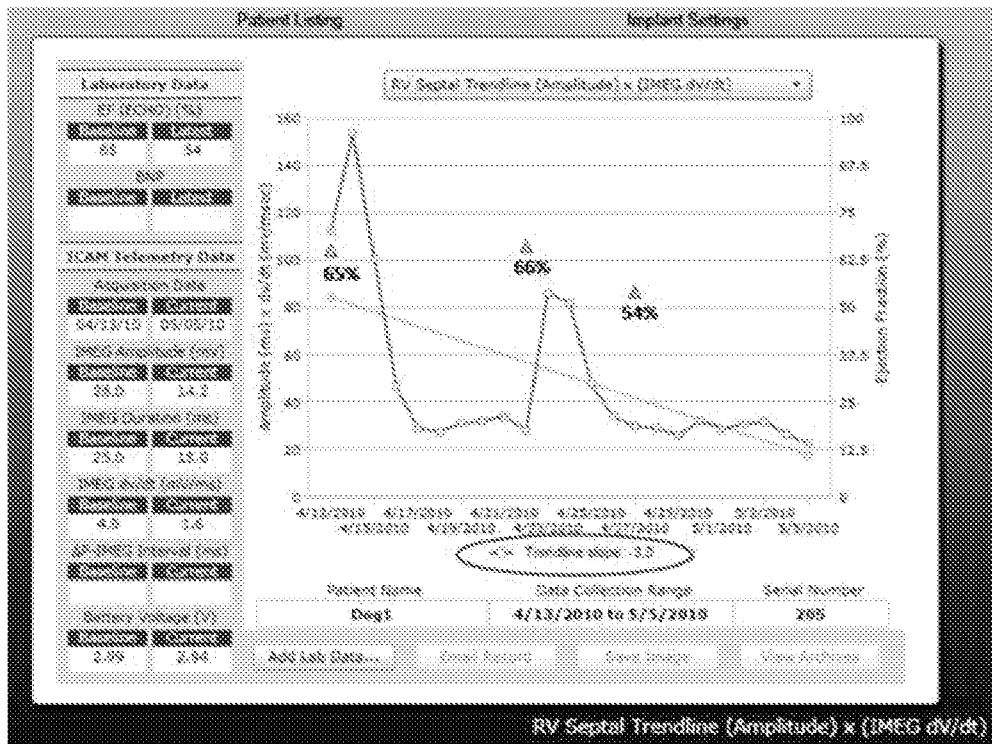

FIG. 36B

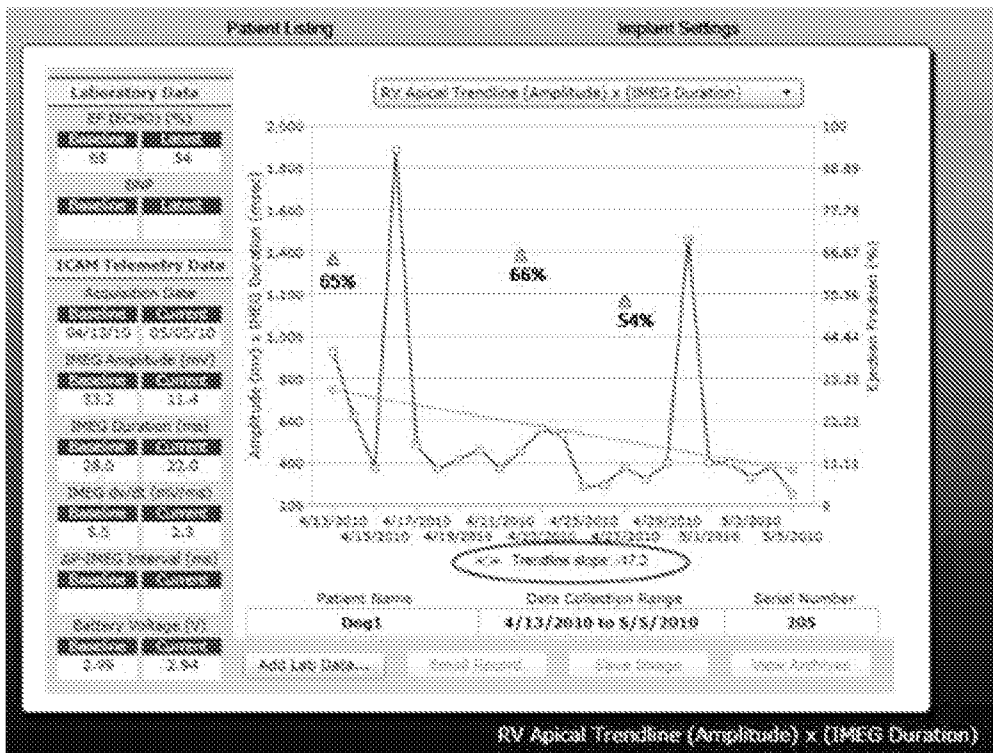

FIG. 36C

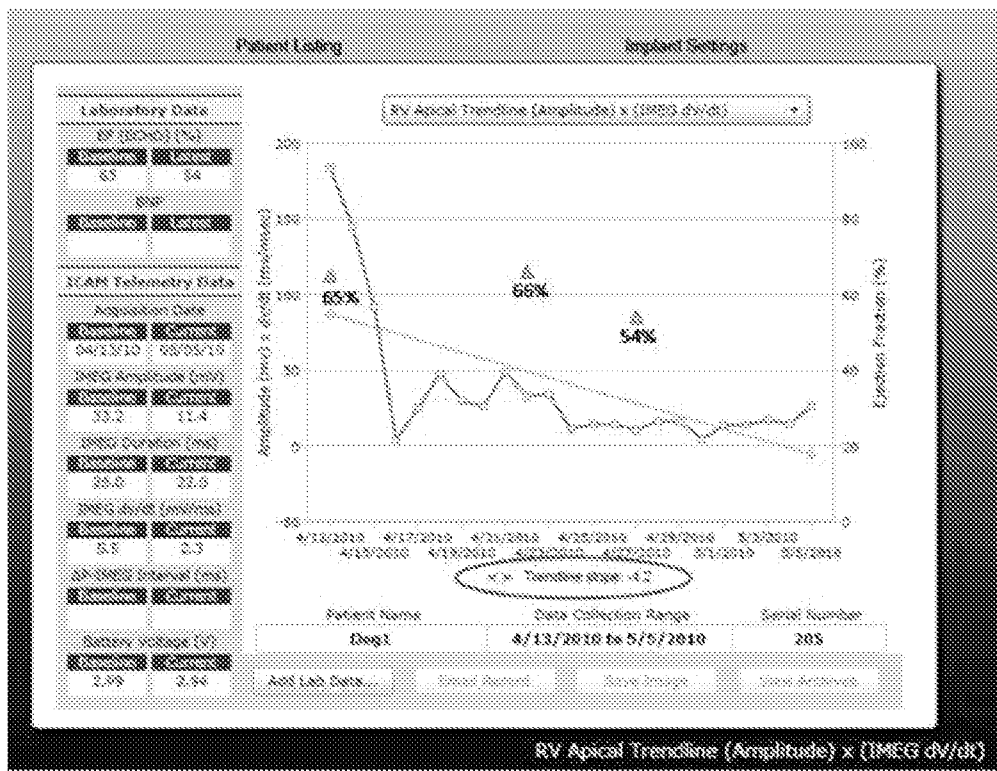
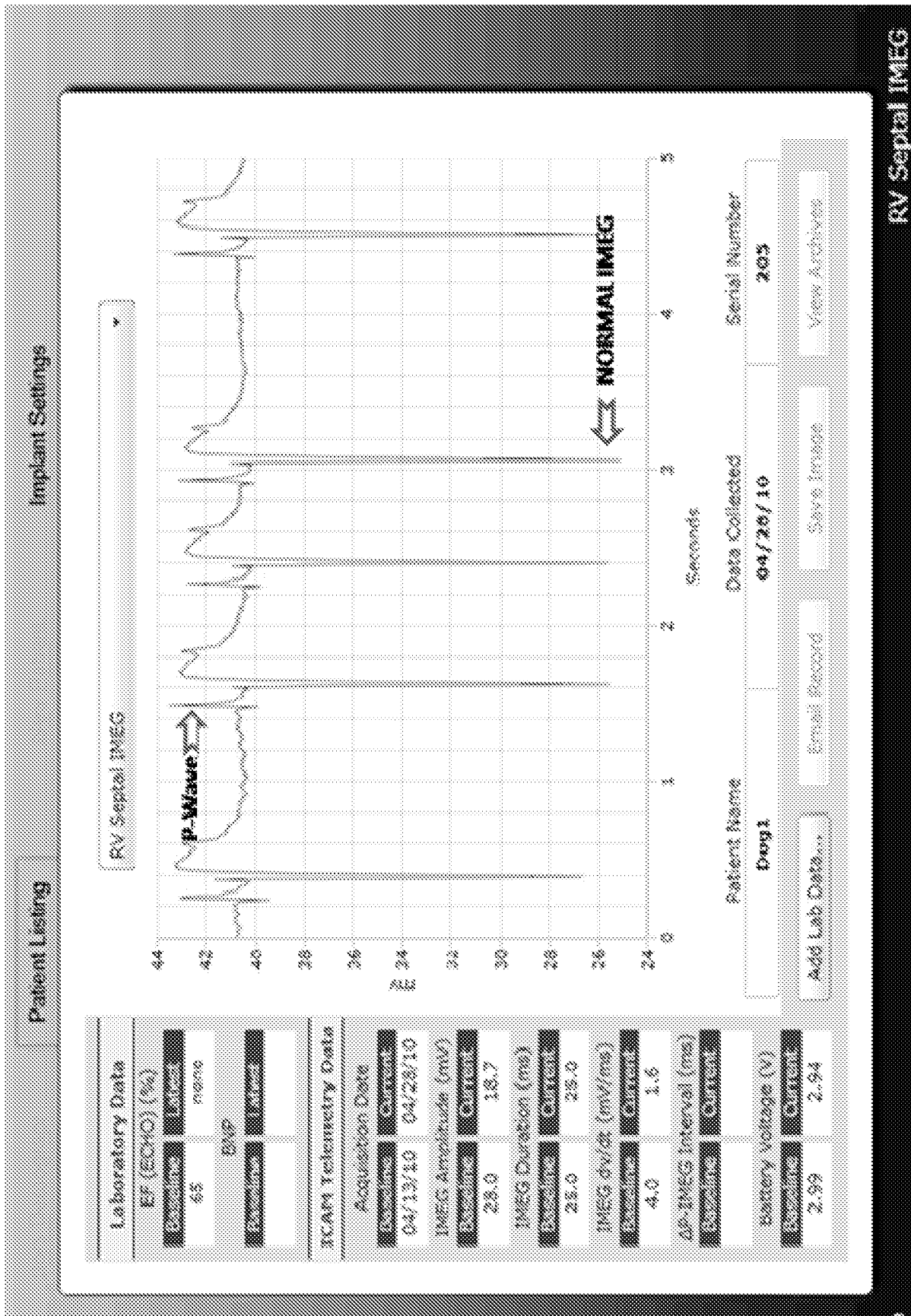

FIG. 36D



RV Septal IMEG

FIG. 37A

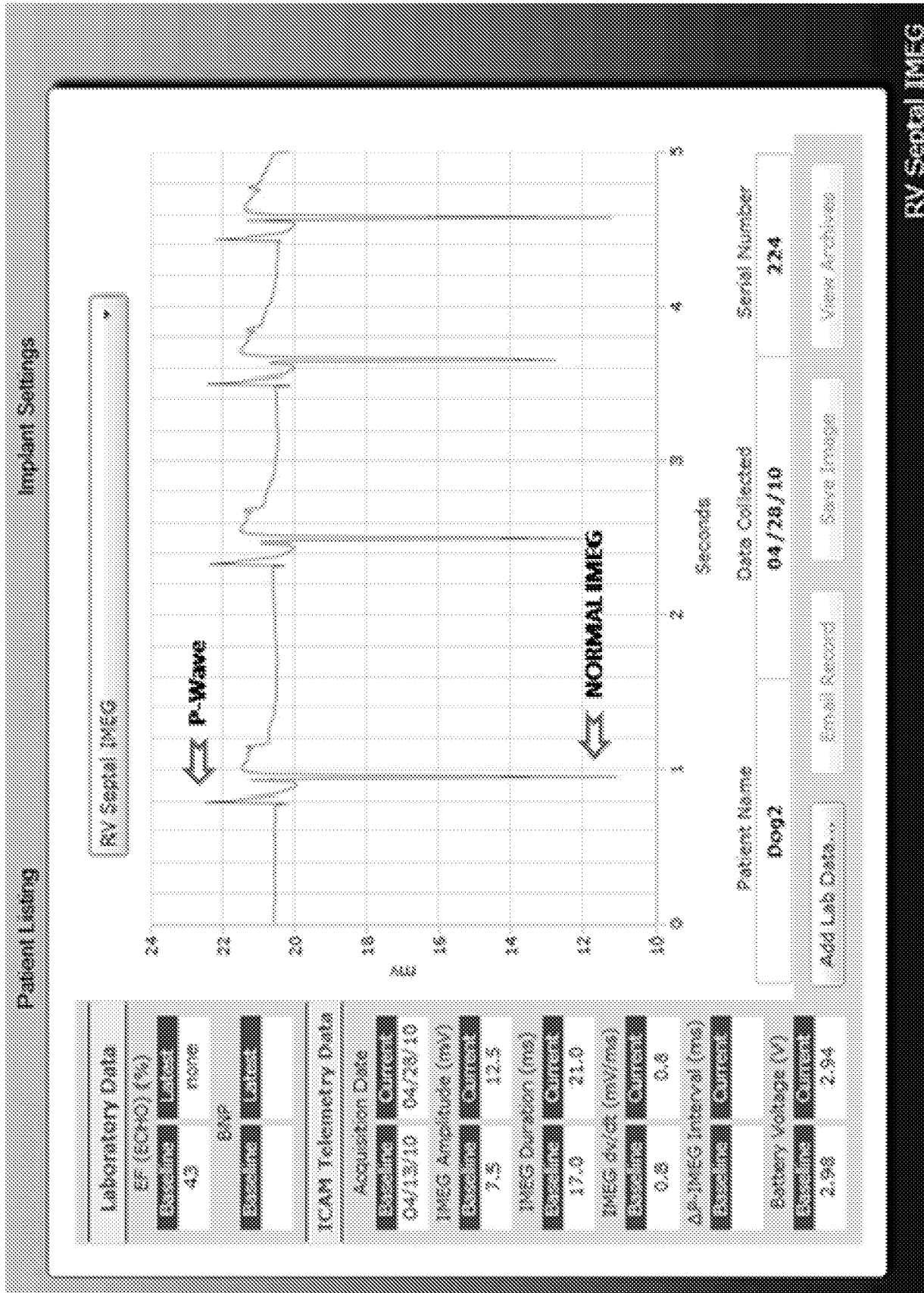
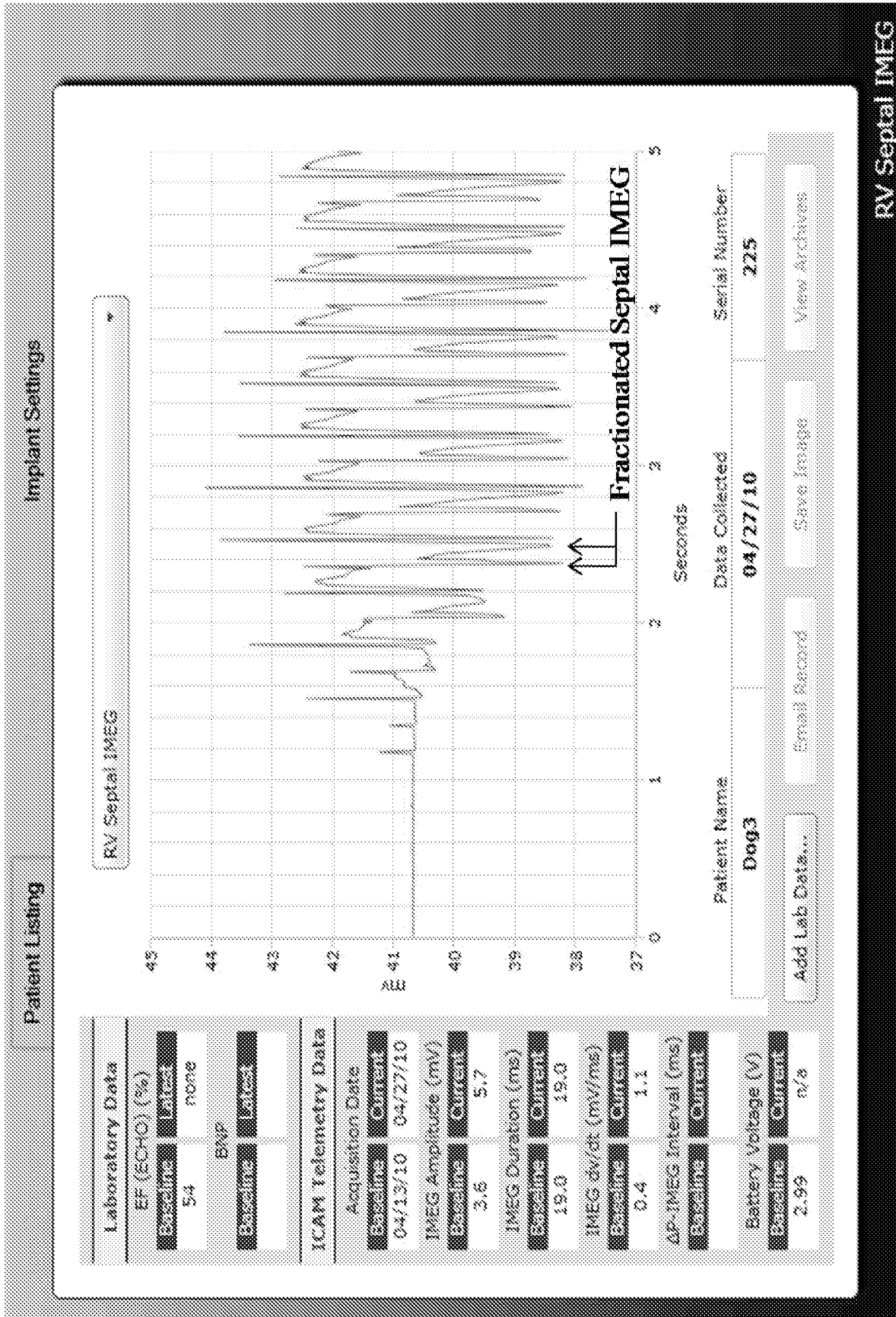

FIG. 37B



RV Septal IMEG

FIG. 37C

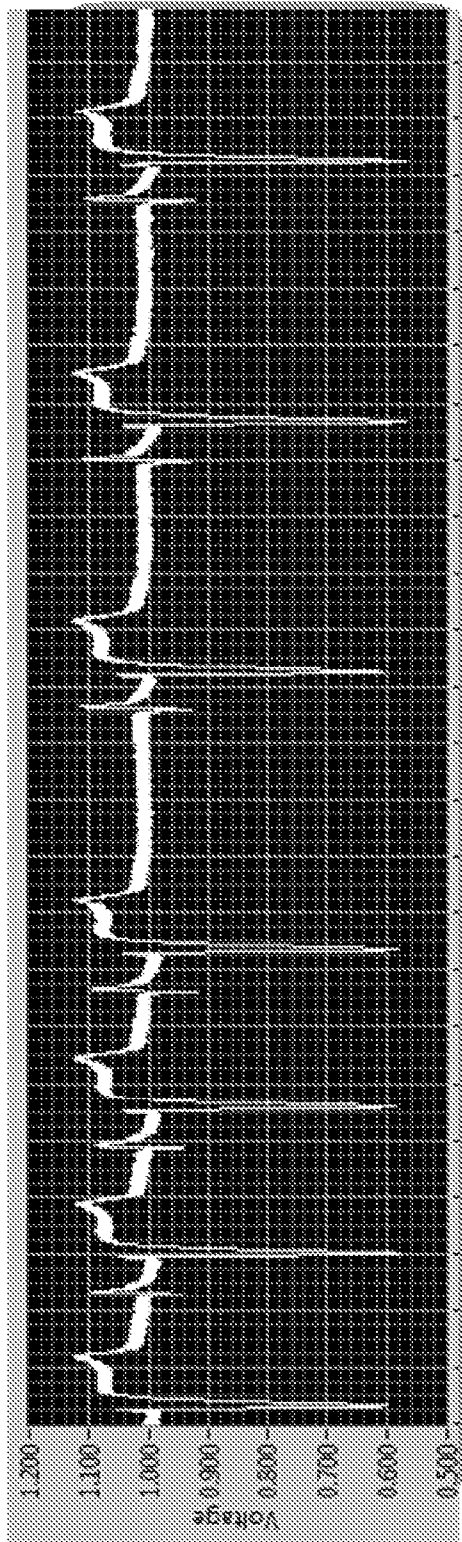

FIG. 38A

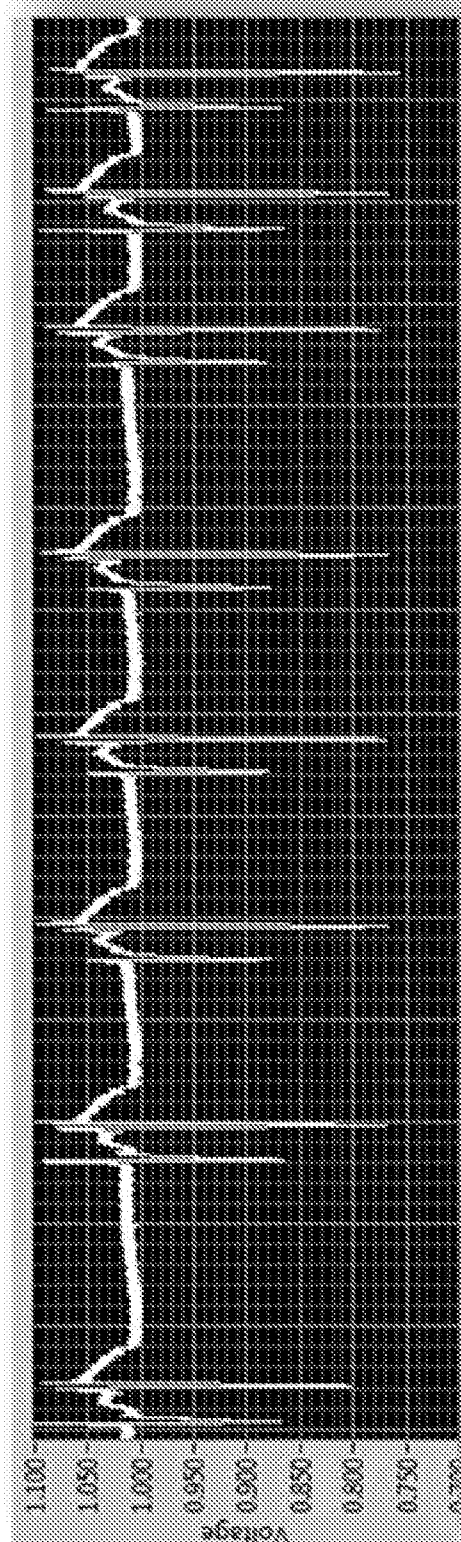

FIG. 38B

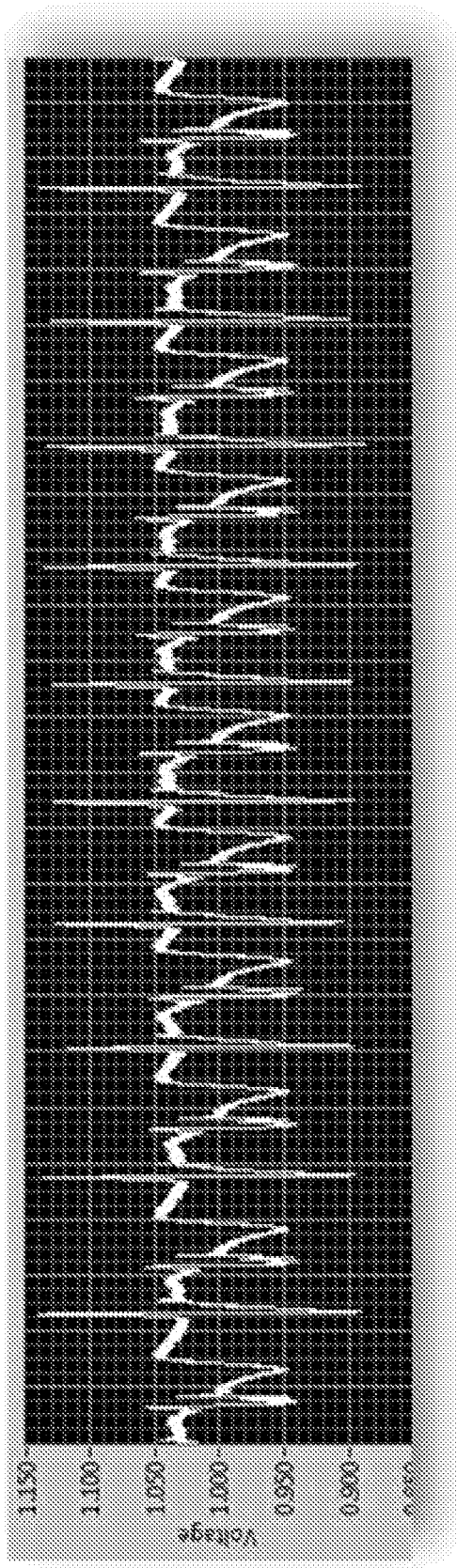

FIG. 38C

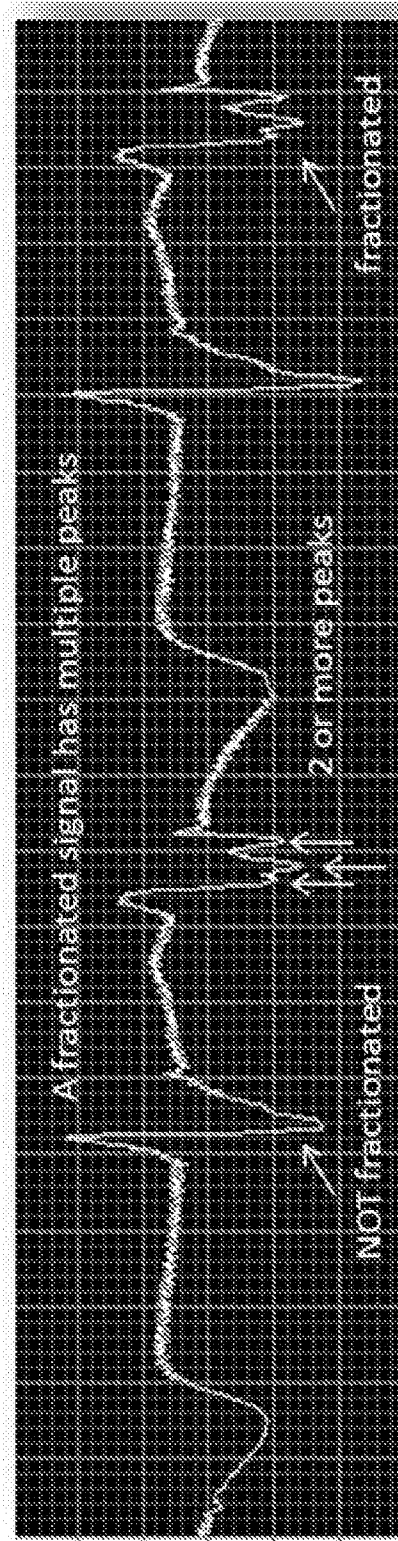

FIG. 38D

**INTERNATIONAL SEARCH REPORT**

International application No.  
PCT/US2010/034121

<b>A. CLASSIFICATION OF SUBJECT MATTER</b> IPC(8) - A61B 5/0402 (2010.01) USPC - 600/509 According to International Patent Classification (IPC) or to both national classification and IPC		
<b>B. FIELDS SEARCHED</b> Minimum documentation searched (classification system followed by classification symbols) IPC(8) - A61B 5/0402, 5/0452 (2010.01) USPC - 600/301, 509, 510, 515, 516, 517, 521 Documentation searched other than minimum documentation to the extent that such documents are included in the fields searched Electronic data base consulted during the international search (name of data base and, where practicable, search terms used) USPTO EAST System (US, USPG-PUB, EPO, DERWENT), GooglePatents		
<b>C. DOCUMENTS CONSIDERED TO BE RELEVANT</b>		
<b>Category*</b>	<b>Citation of document, with indication, where appropriate, of the relevant passages</b>	<b>Relevant to claim No.</b>
Y	US 2005/0113705 A1 (FISCHELL et al) 26 May 2005 (26.05.2005) entire document	1-60, 72-113
Y	US 2007/0232944 A1 (GHANEM et al) 04 October 2007 (04.10.2007) entire document	1-60, 72-113
Y	GB 2,439,562 A (SAUMAREZ) 02 January 2008 (02.01.2008) entire document	1-60, 85, 87
Y	US 2007/0208263 A1 (JOHN et al) 06 September 2007 (06.09.2007) entire document	1-60, 72-113
Y	US 5,595,183 A (SWANSON et al) 21 January 1997 (21.01.1997) entire document	2-4, 22-24, 42-44, 73-75
Y	US 2007/0191722 A1 (RICHARDSON et al) 16 August 2007 (16.08.2007) entire document	5, 12, 13, 17-60, 102, 103, 107
Y	US 2005/0209511 A1 (HERUTH et al) 22 September 2005 (22.09.2005) entire document	7-9, 26-28, 47, 48, 78-80
Y	US 2005/0209519 A1 (KRISHNAN et al) 22 September 2005 (22.09.2005) entire document	12, 32-33, 58, 92-94
<input type="checkbox"/> Further documents are listed in the continuation of Box C. <input type="checkbox"/>		
* Special categories of cited documents: "A" document defining the general state of the art which is not considered to be of particular relevance "E" earlier application or patent but published on or after the international filing date "L" document which may throw doubts on priority claim(s) or which is cited to establish the publication date of another citation or other special reason (as specified) "O" document referring to an oral disclosure, use, exhibition or other means "P" document published prior to the international filing date but later than the priority date claimed		"T" later document published after the international filing date or priority date and not in conflict with the application but cited to understand the principle or theory underlying the invention "X" document of particular relevance; the claimed invention cannot be considered novel or cannot be considered to involve an inventive step when the document is taken alone "Y" document of particular relevance; the claimed invention cannot be considered to involve an inventive step when the document is combined with one or more other such documents, such combination being obvious to a person skilled in the art "&" document member of the same patent family
Date of the actual completion of the international search 03 September 2010		Date of mailing of the international search report <p align="center" style="font-size: 1.5em;"><b>14 SEP 2010</b></p>
Name and mailing address of the ISA/US Mail Stop PCT, Attn: ISA/US, Commissioner for Patents P.O. Box 1450, Alexandria, Virginia 22313-1450 Facsimile No. 571-273-3201		Authorized officer: <p align="center">Blaine R. Copenheaver</p> PCT Helpdesk: 571-272-4300 PCT OSP: 571-272-7774

INTERNATIONAL SEARCH REPORT

International application No.  
PCT/US2010/034121

**Box No. II Observations where certain claims were found unsearchable (Continuation of item 2 of first sheet)**

This international search report has not been established in respect of certain claims under Article 17(2)(a) for the following reasons:

- 1.  Claims Nos.:  
because they relate to subject matter not required to be searched by this Authority, namely:
  
- 2.  Claims Nos.:  
because they relate to parts of the international application that do not comply with the prescribed requirements to such an extent that no meaningful international search can be carried out, specifically:
  
- 3.  Claims Nos.:  
because they are dependent claims and are not drafted in accordance with the second and third sentences of Rule 6.4(a).

**Box No. III Observations where unity of invention is lacking (Continuation of item 3 of first sheet)**

This International Searching Authority found multiple inventions in this international application, as follows:

See extra sheet

- 1.  As all required additional search fees were timely paid by the applicant, this international search report covers all searchable claims.
- 2.  As all searchable claims could be searched without effort justifying additional fees, this Authority did not invite payment of additional fees.
- 3.  As only some of the required additional search fees were timely paid by the applicant, this international search report covers only those claims for which fees were paid, specifically claims Nos.:
- 4.  No required additional search fees were timely paid by the applicant. Consequently, this international search report is restricted to the invention first mentioned in the claims; it is covered by claims Nos.:  
1-60, 72-110

**Remark on Protest**

- The additional search fees were accompanied by the applicant's protest and, where applicable, the payment of a protest fee.
- The additional search fees were accompanied by the applicant's protest but the applicable protest fee was not paid within the time limit specified in the invitation.
- No protest accompanied the payment of additional search fees.

INTERNATIONAL SEARCH REPORT

International application No.

PCT/US2010/034121

Continuation of Box III.

This application contains the following inventions or groups of inventions which are not so linked as to form a single general inventive concept under PCT Rule 13.1. In order for all inventions to be examined, the appropriate additional examination fees must be paid.

Group I, claims 1-60, 72-110, drawn to a method and system comprising generating a status indicator which is proportional to the product of a first parameter and a second parameter of IMEG signals.

Group II, claims 61-71, drawn to a method of using a device to measure time differences between IMEG signals collected from the right ventricular septum and IMEG signals collected from the right ventricular apex.

The inventions listed as Groups I-II do not relate to a single general inventive concept under PCT Rule 13.1 because, under PCT Rule 13.2, they lack the same or corresponding special technical features for the following reasons: the special technical feature of the Group I invention: a status indicator which is proportional to the product of a first parameter and a second parameter as claimed therein is not present in the invention of Group II. The special technical feature of the Group II invention: measuring time differences between IMEG signals collected from the right ventricular septum and IMEG signals collected from the right ventricular apex as claimed therein is not present in the invention of Groups I.

Groups I and II lack unity of invention because even though the inventions of these groups require the technical feature of monitoring heart failure status of a patient by detecting an activity level of a patient; an implanted device collecting IMEG signals at different times when the activity level of the patient is below a preset threshold level for a predetermined period of time; and analyzing the results, this technical feature is not a special technical feature as it does not make a contribution over the prior art in view of US 2005/0113705 A1 (FISCHELL et al) 26 May 2005 (26.05.2005) paragraphs [0013, 0015, 0021, 0027].

Since none of the special technical features of the Group I or II inventions are found in more than one of the inventions, unity of invention is lacking.

专利名称(译)	用于心脏和活动监测的系统和方法		
公开(公告)号	<a href="#">EP2429389A1</a>	公开(公告)日	2012-03-21
申请号	EP2010775305	申请日	2010-05-07
[标]申请(专利权)人(译)	监控信息科技		
申请(专利权)人(译)	监测信息TECHNOLOGIES , INC.		
当前申请(专利权)人(译)	QRS HEART , INC.		
[标]发明人	SHOLDER JASON		
发明人	SHOLDER, JASON		
IPC分类号	A61B5/0402 A61B5/00 A61B5/042 A61B5/0452 A61B5/11 G06F19/00		
CPC分类号	A61B5/042 A61B5/0031 A61B5/0452 A61B5/1118 A61B5/413 A61B5/6882 A61B5/7275 A61B2562 /0219 G16H10/60 G16H15/00 G16H40/63 G16H50/20		
优先权	61/215956 2009-05-13 US 61/240576 2009-09-08 US		
其他公开文献	EP2429389A4		
外部链接	<a href="#">Espacenet</a>		

#### 摘要(译)

用于监测患者的心力衰竭或移植排斥状态的方法和系统，包括使用装置或系统在患者的检测到的活动水平低于预设阈值时自动在不同时间收集来自患者的心肌内电图 ( IMEG ) 信号预定时间量的电平，以及使用设备或系统产生与从至少一部分收集的IMEG信号中提取的参数组合成比例的状态指示值。方法和系统还可以包括测量从患者的不同位置收集的IMEG信号之间的时间延迟值。可以从患者的右心室间隔和右心室尖端或从患者的右心室和左心室心肌收集IMEG信号。