

(19) World Intellectual Property Organization
International Bureau



(43) International Publication Date
9 October 2003 (09.10.2003)

PCT

(10) International Publication Number
WO 03/082390 A1

(51) International Patent Classification⁷: A61M 16/00,
A61B 5/00

(21) International Application Number: PCT/CA03/00399

(22) International Filing Date: 21 March 2003 (21.03.2003)

(25) Filing Language: English

(26) Publication Language: English

(30) Priority Data:
2,379,353 28 March 2002 (28.03.2002) CA

(71) Applicant and

(72) Inventor: FISHER, Joseph [CA/CA]; The Toronto General Hospital, Department of Anesthesia, 200 Elizabeth Street, Toronto, Ontario M5G 2C4 (CA).

(72) Inventors; and

(75) Inventors/Applicants (for US only): PREISS, David [CA/CA]; The Toronto General Hospital, Department of Anesthesia, 200 Elizabeth Street, Toronto, Ontario M5G 2C4 (CA). AZAMI, Takafumi [CA/CA]; The Toronto

General Hospital, Department of Anesthesia, 200 Elizabeth Street, Toronto, Ontario M5G 2C4 (CA). VESELY, Alex [CA/CA]; The Toronto General Hospital, Department of Anesthesia, 200 Elizabeth Street, Toronto, Ontario M5G 2C4 (CA). PRISMAN, Eitan [CA/CA]; The Toronto General Hospital, Department of Anesthesia, 200 Elizabeth Street, Toronto, Ontario M5G 2C4 (CA). ADAMS, Tehilla [CA/CA]; The Toronto General Hospital, Department of Anesthesia, 200 Elizabeth Street, Toronto, Ontario M5G 2C4 (CA).

(74) Agent: HUGHES, Ivor, M.; Barrister & Solicitor, Patent & Trademark Agents, 175 Commerce Valley Drive West, Suite 200, Thornhill, Ontario L3T 7P6 (CA).

(81) Designated States (national): AE, AG, AL, AM, AT, AU, AZ, BA, BB, BG, BR, BY, BZ, CA, CH, CN, CO, CR, CU, CZ, DE, DK, DM, DZ, EC, EE, ES, FI, GB, GD, GE, GH, GM, HR, HU, ID, IL, IN, IS, JP, KE, KG, KP, KR, KZ, LC, LK, LR, LS, LT, LU, LV, MA, MD, MG, MK, MN, MW, MX, MZ, NO, NZ, OM, PH, PL, PT, RO, RU, SC, SD, SE, SG, SK, SL, TJ, TM, TN, TR, TT, TZ, UA, UG, US, UZ, VC, VN, YU, ZA, ZM, ZW.

(84) Designated States (regional): ARIPO patent (GH, GM, KE, LS, MW, MZ, SD, SL, SZ, TZ, UG, ZM, ZW),

[Continued on next page]

(54) Title: METHOD FOR CONTINUOUS MEASUREMENT OF FLUX OF GASES IN THE LUNGS DURING BREATHING

Schematic diagram of Magill circuit, Mapleson A configuration

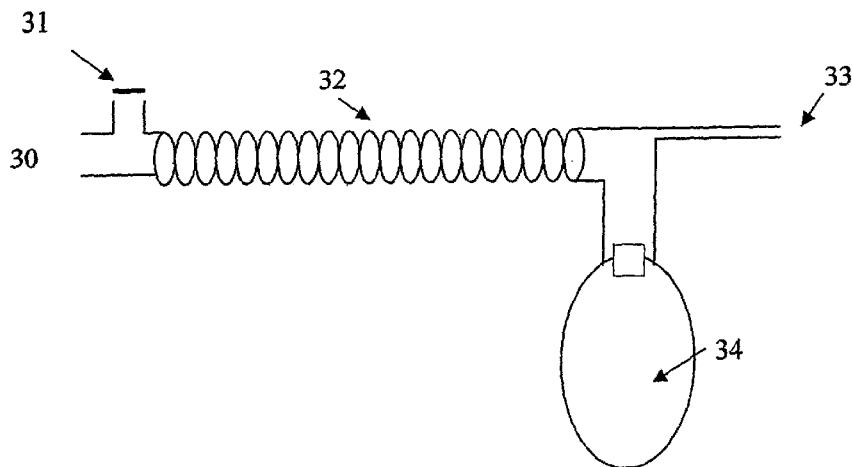

(57) Abstract: A method of calculating the flux of any gas(x) in a CBC circuit for a ventilated or a spontaneous breathing subject, for example said gas(x) being: a) an anesthetic such as but limited to ; i)N₂O ; ii) sevoflurane ; iii) isoflurane ; iv) halothane ; v) desflurane ; or the like b) Oxygen ; c) Carbon dioxide ; or the like utilizing the following relationships ; Flux of gas(x) = SGF (F_{SX} - F_{EX}) wherein SGF = Source of gas flow into the breathing circuit (CBC circuit) in liters/minute as read from the gas flow meter as set by the anesthesiologist ; F_{SX} = Fractional concentration of gas X in the source gas (which is set by the anesthesiologist) ; F_{EX} = Fractional concentration of gas X in the end expired gas as determined by a portable gas analyzer, or the like.



WO 03/082390 A1



Eurasian patent (AM, AZ, BY, KG, KZ, MD, RU, TJ, TM),
European patent (AT, BE, BG, CH, CY, CZ, DE, DK, EE,
ES, FI, FR, GB, GR, HU, IE, IT, LU, MC, NL, PT, RO,
SE, SI, SK, TR), OAPI patent (BF, BJ, CF, CG, CI, CM,
GA, GN, GQ, GW, ML, MR, NE, SN, TD, TG).

— *before the expiration of the time limit for amending the
claims and to be republished in the event of receipt of
amendments*

Published:

— *with international search report*

*For two-letter codes and other abbreviations, refer to the "Guid-
ance Notes on Codes and Abbreviations" appearing at the begin-
ning of each regular issue of the PCT Gazette.*

TITLE OF INVENTIONMETHOD FOR CONTINUOUS MEASUREMENT OF FLUX OF GASES
IN THE LUNGS DURING BREATHING5 **FIELD OF INVENTION**

This invention relates to a method of measuring uptake and elimination via the lung of all gases for example including, but not limited to, anesthetics, oxygen and carbon dioxide.

10 **BACKGROUND OF THE INVENTION**

The following represents a glossary of terms used within the specification. The reader is referred to these definitions when interpreting the meaning of any description herein.

- 15 1) \dot{V}_E : minute ventilation (the total volume of gas breathed in and out of the lung per minute). P_{ETCO_2} : end tidal PCO_2 (the partial pressure of CO_2 at end exhalation);
- 2) SGF: source gas flow (the flow of gas into a breathing circuit, in liters/min);
- 3) \dot{V}_A : alveolar ventilation (that ventilation that results in gas exchange between
20 the pulmonary capillaries and the air spaces (alveoli) of the lung), expressed in liters/min. It is also defined as the total ventilation minus the ventilation of the anatomic dead space ($\dot{V}_E - \dot{V}_{Dan}$);
- 4) $\dot{V}O_2$: The O_2 consumed in liters per minute;

- 5) $\dot{V}CO_2$: The CO_2 produced in liters per minute;
- 6) F_{Sx} : fractional concentration of a gas x in source gas (gas entering a breathing circuit);
- 7) F_{Ix} : fractional concentration of gas x in inspired gas (gas entering the patient's lungs);
- 8) F_{Ex} : the fractional concentration of gas x in end expired gas;
- 9) CBC (conditional breathing circuit): a breathing circuit in which only exhaled gas, and no source gas, exits from the circuit, as would be the case with a circle circuit with a low flow of gas entering the circuit, or a Magill circuit in which a) SGF is $\leq 0.7 \times \dot{V}_E$; b) the common breathing tube volume (see figure 1) is greater than or equal to the sum of [($SGF \times$ expiratory time) + the anatomical dead space]; c) the volume of the breathing bag is greater than [the largest expected tidal volume – ($SGF \times$ inspiratory time)].

15 Introduction

The measurement of uptake and elimination of gases via the lungs plays an important role in medicine. Oxygen consumption ($\dot{V}O_2$) and CO_2 production ($\dot{V}CO_2$) are two important parameters indicating cardio-respiratory fitness of athletes. $\dot{V}O_2$ and $\dot{V}CO_2$ are also used as important indicators of the efficacy of therapeutic intervention in critically ill patients. The ability to impose a transient change in $\dot{V}O_2$ and $\dot{V}CO_2$ allows one to calculate such important physiological parameters as cardiac output and functional residual capacity. For the most part,

anesthesia is induced and maintained by gases taken up by and eliminated from the body via the lungs. Accurate measurement and control of uptake and elimination of anesthetic gases would improve the control of anesthetic depth and thereby the effectiveness and efficiency of the use of anesthetic gases. Accurate control of uptake and elimination of therapeutic gases would allow more controlled dosing when these gases are used as therapies for illness. Accurate control of uptake and elimination of inert gases via the lung can be used for various diagnostic and research purposes.

10 Present Art

Measuring gas flux

Measuring total gas flux requires the measurement of gas volumes for discrete periods of time and multiplying these volumes by the concentration of the gas in the volume.

15

Volume measurements

Measurement of exhaled gas volumes is very cumbersome in clinical or research settings. One method requires timed collections of exhaled gas in bags and then measuring the volume of the bags. Inhaled volumes are even more awkward to measure continuously as the volumes enter the lung and one must measure the volume of lung expansion or the volume depleted from a previously known volume. This cannot be done breath-by-breath. These measurements are usually simplified by measuring flow continuously at the mouth and integrating the flow

electronically with respect to time to obtain “continuous” measures of volume. Each type of flow measuring device has inherent problems leading to inaccuracy of calculation of volume (see below).

5 *Flux measurements*

To measure the flux of a particular constituent (gas x) of the total gas that enters or exits the lung is more complex. The concentration of x sampled at the mouth during breathing changes between inhalation and exhalation as well as continuously during each ventilatory phase. Therefore, to measure the flux of gas x , the concentration of gas x must be measured continuously with a rapidly responding gas analyzer, and the average concentrations over short intervals must be multiplied by the volume changes over those same intervals. This requires synchronization of flow-volume signals and gas concentration signals, then multiplying the values and continuously summing them. A number of devices on the market such as the Vmax (Sensormedics, Yorba Linda CA), Medical Graphics CPOX/D, (Medical Graphics Corporation, St. Paul, Minnesota) and NICO (Novamatrix, Wallingford, CT) measure the fluxes of CO₂ and/or O₂ at the mouth using this method. The same principles apply to measuring the flux of other gases if appropriate gas sensors are used.

Measuring gas fluxes during anesthesia

a) *Understanding the anesthetic circuits*

One circuit used for anesthesia is the Magill circuit with the Mapleson A configuration illustrated in figure 1 ("Magill circuit"). The patient breathes through the patient port (30). During inhalation, gas is drawn from the source gas port (33) and the gas reservoir bag (34) along the common breathing tube (32). Expiration is divided into two phases. The first phase lasts from the beginning of exhalation until the filling of the gas reservoir bag (34). During this first phase of exhalation, expired gas proceeds down the common breathing tube (32) with gas from the anatomical dead space preceding gas from the alveoli. Expired gas displaces gas in the breathing tube (32) into the gas reservoir bag. During this phase of exhalation the source gas is also directed into the gas reservoir bag. The second phase of exhalation is from the time of filling of the gas reservoir bag (34) until the beginning of inhalation. During this second phase of exhalation, the expired gas exits through the one way pressure relief valve (31) that has an opening pressure of about 2 cm H₂O and the source gas proceeds along the common breathing tube (32) displacing gas before it and forcing it out of the pressure relief valve such that the last exhaled (alveolar gas) exits the valve first.

Kain and Nunn (Kain M.L., Nunn J.F. *Anesthesiology*. 29: 964-974, 1968) determined the minimum source gas flow required to prevent rebreathing in anesthetized patients breathing through the circuit by sequentially decreasing

the source gas flow until minute ventilation and end tidal PCO_2 increased. It is generally accepted that the source gas flow needed to prevent rebreathing of alveolar gas is 70% of the minute ventilation (\dot{V}_E) (Understanding Anesthesia Equipment by Dorsch J.A., and Dorsch S.E., Williams & Wilkins Co. 1975, pg.169). The 30% savings in source gas is due to the rebreathing of the anatomical dead space gas which does not undergo gas exchange in the alveoli and therefore retains the same composition as source gas.

The 30% savings in source gas flow with the Magill breathing circuit represents the maximum efficiency available for source gas without the use of a CO_2 absorber. As the cost of anesthesia varies directly with the flow of source gas, circuits with CO_2 absorbers, the most popular being the "circle circuit" depicted in figure 2, allows a marked reduction in source gas flow (SGF) without causing a rise in end tidal PCO_2 . The balance of \dot{V}_E is provided by rebreathing of previously exhaled gases and the CO_2 absorber (6) prevents the build-up of CO_2 in the circuit and the patient. As not all of the delivered anesthetic is extracted during a breath, exhaled gas has a considerable concentration of anesthetic that can be re-supplied to the patient when rebreathed. The circle circuit contains a patient port (1), and an expiratory limb (2) leading to a one way expiratory valve (3). Distal to the valve there is a flexible gas reservoir (4), a pressure relief valve (5) where excess expired gas is vented, and a container for CO_2 -absorbing crystals (6). When the patient inhales, he draws fresh gas entering the fresh gas inlet (7)

and makes up the balance of inspired gas by drawing gas from the gas reservoir through the CO₂-absorber. The source gas and the previously exhaled gas join to flow through the one-way inspiratory valve (8) to the patient through the inspiratory limb (9). When the patient exhales, gas passes down the expiratory limb of the circuit (2), past the expiratory valve (3), and enters the flexible gas reservoir (4). When the gas reservoir fills to capacity, pressure in the circuit increases and the pressure relief valve (5) opens, releasing gas to atmosphere during the remainder of exhalation. During exhalation, fresh gas entering the circuit (7) is displaced back into the CO₂ absorber (6). This fresh gas enters the inspiratory limb (9) and is made available to the patient on subsequent breath(s).

The depletion of O₂ and anesthetic from the circuit is prevented by re-supplying both gases through the fresh gas inlet (7). The anesthesiologist can control the total flow of gas as well as the concentrations of all its constituent components such as oxygen, nitrous oxide and anesthetic agent. The minimum gas flow into the circuit is that needed to replace the oxygen consumed and anesthetic absorbed by the body. The CO₂ absorbers extract only CO₂, allowing other gases to pass through unchanged.

b) Calculation of uptake or elimination of gases with rebreathing circuits (present art):

When a subject breathes via a Magill, circle, or Fisher isocapnia (rebreathing and non-rebreathing) circuit, and the SGF entering the circuit is equal to or greater than \dot{V}_E , the circuit acts like a nonrebreathing circuit, i.e., inspired concentration of gas x is that of the SGF, i.e., F_{Sx} . When SGF is less than \dot{V}_E , inspired gas is composed of both SGF and previously exhaled gas in the Magill, circle and Fisher rebreathing isocapnia circuit; and composed of SGF and reserve gas in the Fisher non-rebreathing isocapnia circuit. As a result, the concentration of x varies throughout inspiration in a complex way depending on \dot{V}_E , pattern of breathing, and SGF. To measure the inspired volume of x , inspiration must be broken up into small intervals during which the total volume must be multiplied by the average concentration of x ; the resulting discrete volumes of x must be summed for the duration of inspiration. Similarly, to calculate the expired volume of x , continuous measurements of expired flows and expired concentrations of x are required. The net uptake or elimination of x over a given time is the algebraic sum of the inhaled and exhaled volumes of x during that time.

Reference List

1. Kain ML, Nunn JF. Fresh gas economics of the Magill Circuit. *Anesthesiology*
5 1968;29(5):964-74.
2. Wissing H, Kuhn I, Rietbrock S, Fuhr U. Pharmacokinetics of inhaled
anaesthetics in a clinical setting: comparison of desflurane, isoflurane and
sevoflurane [see comments]. *Br.J Anaesth.* 2000;84(4):443-9.
3. Rietbrock S, Wissing H, Kuhn I, Fuhr U. Pharmacokinetics of inhaled
10 anaesthetics in a clinical setting: description of a novel method based on
routine monitoring data [see comments]. *Br.J Anaesth.* 2000;84(4):437-42.
4. Bouillon T, Shafer SL. Hot air or full steam ahead? An empirical
pharmacokinetic model of potent inhalational agents [editorial; comment]
[published erratum appears in *Br J Anaesth* 2000 Jun;84(6):833]. *Br.J Anaesth.*
15 2000;84(4):429-31.

It is an object of this invention is to provide a simpler and more accurate method of measuring uptake and elimination via the lung of all gases for example including, but not limited to, anesthetics, oxygen and carbon dioxide.

It is a further object of this invention is to provide a method of controlling gas flux (defined as uptake or elimination from the lung) independent of minute ventilation.

5 Further and other objects of the invention will become apparent to those skilled in the art when considering the following summary of the invention and the more detailed description of the preferred embodiments illustrated herein.

SUMMARY OF THE INVENTION

10 According to a primary aspect of the invention we provide a method of measuring the flux of any gas by utilizing SGF times expired concentration of that gas. This is especially applicable in the operating room where all of the equipment required to provide the necessary information is already in use: the circuit, the SGF flowmeters, the gas sensors.

15

The ability to make a step change in \dot{V}_A via a change in SGF or F_{Sx} can be used to obtain a control measurement of \dot{V}_A as well as cardiac output by two different methods, the Gideon method and the Fisher method. This proffers marked advantages on these methods with respect to versatility, cost, and accuracy.

20

The method relates to the novel application of known circuits for measurements of gas flux. Further three new circuits that allow the use of the method outside the operating room in ventilated patients/subjects are also provided, a) the Magill

configured for controlled ventilation; b) the rebreathing isocapnia circuit configured for controlled ventilation; and c) the balloon valve circuit.

With reference to the gas input the following conditions apply/result:

- 5
- Breathing via a circuit in which the total flow of gas entering the circuit is less than or equal to the subject's alveolar ventilation,
 - The balance of gas inhaled is composed of gas that has substantially the same concentration of gas x as is in the alveoli of the lung
 - This gas may actually be previously exhaled gas that has been stored

10

 - and made available to be rebreathed, or it may come from an external gas source in which the concentration of x is substantially the same as that in the alveoli of the lung
 - The input gas flow and concentration of x in input gas are known and determined by the user

15

The continuous measurement of expired gas concentrations is possible by utilizing a convenient gas analyzer. Based on the known values therefore that will be further described herein after;

- The rate of elimination of gas $x = \text{SGF} \times (\text{FEx} - \text{FSx})$ for any CBC circuit

20

- as described herein.
- The rate of elimination of gas $x = \text{the input total gas flow} \times (\text{FEx} - \text{FIx})$, where FIx is the concentration of x in inspired gas
- *Gas input parameters*

- Breathing via a circuit in which the total flow of gas entering the circuit is less than or equal to the subject's alveolar ventilation,
- The balance of gas inhaled is composed of gas that has substantially the same concentration of gas x as is in the alveoli of the lung
- 5 • This gas may actually be previously exhaled gas that has been stored and made available to be rebreathed, or it may come from an external gas source in which the concentration of x is substantially the same as that in the alveoli of the lung
- The input gas flow and concentration of x in input gas are known and
10 determined by the user

According to one aspect of the invention there is provided a method of calculating the flux of any gas(x) in a CBC circuit for a ventilated or a spontaneous breathing subject,

15

for example said gas(x) being;

a) an anesthetic such as but limited to;

i) N₂O;

20

ii) sevoflurane;

iii) isoflurane;

iv) halothane;

v) desflurane;

or the like

b) Oxygen;

c) Carbon dioxide;

or the like

5

utilizing the following relationships;

$$\text{Flux of gas}(x) = \text{SGF} (F_{\text{SX}} - F_{\text{EX}})$$

10 wherein

SGF = Source of gas flow into the breathing circuit (CBC circuit) in liters/minute as read from the gas flow meter as set by the anesthesiologist;

15 F_{SX} = Fractional concentration of gas X in the source gas (which is set by the anesthesiologist);

F_{EX} = Fractional concentration of gas X in the end expired gas as determined by a portable gas analyzer, or the like.

20

According to another aspect of the invention there is also provided a method of calculating the flux of oxygen in a CBC circuit for a ventilated and/or spontaneous breathing subject utilizing the following relationship;

$$\text{Flux of oxygen} = \text{SGF} (F_{\text{SO}_2} - F_{\text{EO}_2})$$

wherein

5

SGF = Source of gas flow into the breathing circuit (CBC circuit) in liters/minute as read from the gas flow meter as set by the anesthesiologist;

F_{SX} = Fractional concentration of gas O_2 in the source gas (which is set by
10 the anesthesiologist);

F_{EX} = Fractional concentration of gas O_2 in the end expired gas as determined by a portable gas analyzer, or the like.

15 In one embodiment for the abovementioned methods the CBC circuit is selected from the group consisting of i) a circle circuit; ii) a Magill breathing circuit; iii) an isocapnia circuit, whether breathing or non-breathing (as taught by co-pending Fisher et al), or the like.

20 In another embodiment for the abovementioned methods the CBC circuit is an improved Magill circuit as described herein.

In yet another embodiment for the abovementioned methods the CBC circuit is an improved rebreathing circuit as described herein.

In yet another embodiment for the abovementioned methods the CBC circuit is an improved non-rebreathing circuit as described herein.

Preferably in yet another embodiment the abovementioned methods are used to determine oxygen consumption in order to measure cardiac out put by any known method, such as the Fick method.

10

Preferably in yet another embodiment the abovementioned methods are used to determine oxygen consumption in, for example, an operating room setting or the like. Preferably in yet another embodiment the abovementioned methods are used to optimize oxygen consumption. Preferably the abovementioned methods are utilized as an early indication of malignant hyperthermia.

15

According to yet another aspect of the invention there is provided a method of calculating the flux of any gas other than carbon dioxide, in a CBC circuit with low gas flow of source gas and with a carbon dioxide absorber in place utilizing the following relationship;

20

$$\text{Flux of gas X} = \text{SGF} (\text{FEX} - \text{FRBX})$$

wherein

SGF = Source of gas flow into the breathing circuit (CBC circuit) in liters/minute as read from the gas flow meter as set by the anesthesiologist;

5

F_{EX} = Fractional concentration of gas X in the end expired gas as determined by a portable gas analyzer, or the like;

F_{RBX} = Concentration of gas X in the expired limb of circuit before the gas
10 passes through the carbon dioxide absorber and mixes with gas coming from the flow meter.

Preferably in yet another embodiment the abovementioned methods are used to determine the flux of an anesthetic for example:

15

i) N₂O;

ii) sevoflurane;

iii) isoflurane;

iv) halothane;

20

v) desflurane,

or the like

Preferably said methods are used to determine how much anesthetic is being absorbed by the patient. Preferably said anesthetic is N₂O.

According to yet another aspect of the invention there is provided an improved
5 Magill circuit the improvement comprising an inspiratory and expiratory limbs, a pressure relief valve at the end of the expiratory limb, a port for entry of SGF, and a gas reservoir bag, the components of the Magill system utilized for spontaneous ventilation; or alternatively for controlled ventilation, the gas reservoir bag is enclosed in a container with a port for connection to a ventilator breathing circuit,
10 the pressure relief valve being enclosed in a container with a port for connection to a ventilator breathing circuit;

wherein on exhalation, the patient breathes out through the patient port and during the initial part of exhalation, the gas reservoir is partially empty and the
15 resistance to flow along the inspiratory limb is less than that of the expiratory limb because the higher opening pressure of the pressure relief valve must be overcome before flow can proceed through the expiratory limb,

wherein during the initial part of expiration, the expired gas enters the inspiratory
20 limb, displacing gas in the inspiratory limb and from the SGF into the gas reservoir, as the gas reservoir fills, the pressure in the circuit increases above the opening pressure of the pressure relief valve and the remainder of the expired gas is directed down the expired limb displacing the gas out of the expired limb

through the pressure relief valve to the ventilator breathing circuit from where it is eventually vented to atmosphere through the expiratory port and the SGF continues to flow towards the patient down the inspiratory limb, displacing previously exhaled gas into the expiratory limb;

5

wherein during inhalation, the balloon valve occludes the ventilator circuit expiratory port and a volume of gas equal to a tidal volume is delivered by the ventilator into the ventilator circuit and hence into the SGF gas reservoir box, thereby displacing a volume equal to the tidal volume from the SGF gas reservoir into the inspiratory limb of the Magill circuit, the SGF continues to flow towards the patient down the inspiratory limb;

10

wherein the net tidal volume of the patient is equal to the volume displaced from the gas reservoir plus the SGF multiplied by the duration of inspiration, because the pressures on both sides of the Magill pressure relief valve are equal during inspiration, the differential pressure provided by the "opening pressure" of the valve keeps it closed during inspiration;

15

assuming that:

20

(1) the volume of the inspiratory limb is greater than or equal to [(SGF x expiratory time) + the anatomical dead space]; and the breathing bag

volume is greater than [the largest expected tidal volume – (SGF x inspiratory time)],

$$(2) \quad \text{SGF is } \leq 0.7 \times \dot{V}_E$$

5 According to yet another aspect of the invention there is provided an improved rebreathing isocapnia circuit comprising a Y piece with a patient port, and inspiratory limb of the Y piece with a one way inspiratory valve and an expiratory limb of the Y piece with a one way expiratory valve; the inspiratory limb being connected to a SGF and a gas reservoir, the expiratory limb leading to an
10 expiratory gas reservoir, the expiratory gas reservoir having a one way valve at the port where expired gases are vented from the expired gas reservoir which allows gas to exit the expiratory gas reservoir but not enter, having disposed between the expiratory limb and the inspiratory limb distal to the inspiratory and expiratory valves a bypass limb that contains a one-way valve with an opening
15 pressure of the valve, being for example approximately 1.5 cm H₂O, greater than the valves in the inspiratory limb of the Y piece and the expiratory limb of the Y piece; the direction of opening of the one-way valve in the bypass limb being from the expiratory limb to the inspiratory limb, the inspiratory and expiratory limbs being extended by tubing of variable lengths, the inspiratory and expiratory
20 reservoirs being enclosed in a box with 3 ports; one port communicates with the box, one port communicates with the interior of the SGF reservoir only, one port communicates with the expiratory gas reservoir, the SGF reservoir is continuous with the inspiratory limb of the circuit, the expiratory gas reservoir is continuous

with the expiratory limb of the circuit and has a port through which expired gas exits the expired gas reservoir and enters the box, a ventilator, a mushroom valve synchronized to occlude the ventilator circuit expiratory port during the inspiratory phase attached to the box ventilator port such that during the
5 inspiratory phase, the tidal volume of the ventilator is discharged into the box , which will displace an equal volume from the gas reservoirs in the box; as the valve in the bypass limb has a greater opening pressure than the inspiratory valve, the inspiratory reservoir will be compressed in preference to the expiratory reservoir, when the inspiratory reservoir is collapsed, the remainder of the tidal
10 volume will result from compression of the expiratory reservoir and displacement of gas through the bypass limb and valve and inspiratory valve to the patient, the total tidal volume will be equal to the volume displaced from the inspiratory reservoir plus the volume displaced from the expiratory reservoir plus the SGF multiplied by the time during inspiration; during exhalation, the balloon valve is
15 deflated, opening the expiratory port of the ventilator circuit to atmosphere and the expiratory reservoir bag to atmosphere via the port, thus allowing exhaled gas to flow past the expiratory one-way valve down the expiratory limb into the expiratory reservoir, SGF flowing into the port being directed down the inspiratory limb to the SGF reservoir, wherein gas is displaced in the box by
20 expansion of the SGF reservoir and the expiratory gas reservoir is displaced from the box via the ventilator expiratory port; wherein SGF is less than or equal to \dot{V}_E
- \dot{V}_{Dan} .

According to yet another aspect of the invention there is provided an improved non-rebreathing circuit, the improvement comprising a balloon valve circuit for spontaneous ventilation of a patient breathing spontaneously, said circuit having a Y piece with a patient port, an inspiratory limb including a balloon valve,
5 connected to SGF and a gas reservoir, an expiratory limb consisting of a balloon valve leading to an expiratory gas reservoir, which has a port opening to the atmosphere, a tank of compressed air flows through solenoid valves to open or close the balloon valves, the solenoid valves being controlled electronically by a computer, a pressure transducer connected to a mouthpiece for measuring when
10 the fresh gas reservoir has been fully collapsed, the computer for receiving the signal and sending a signal to the solenoid valve to close the inspiratory valve and open the expiratory valve, the fresh gas flow continuously filling the fresh gas reservoir.

15 Preferably any previous method described herein may be used to calculate the rate of elimination of a gas X for any input total gas flow utilizing the following further relationships;

wherein the rate of elimination of gas X = the input total gas flow (multiplied by)

20 $F_{EX} - F_{IX}$;

wherein F_{EX} is defined above and F_{IX} is the concentration of X in inspired gas.

Preferably said method is incorporated in an algorithm spreadsheet, formula or the like contained within software which is capable of running on a computing device, or is installed therein.

5 BRIEF DESCRIPTION OF THE DRAWINGS

In the following examples, there are described several preferred embodiments to illustrate the invention. However, it should be understood that the invention is not intended to be limited to the specific embodiments.

10

Figure 1 is schematic diagram of a typical Magill circuit having a Mapleson A configuration.

Figure 2 is schematic diagram of a typical circle anaesthetic circuit.

Figure 3 is schematic diagram of an improved Magill circuit having a
15 Mapleson A configuration for controlled ventilation illustrated in one embodiment of the invention.

Figure 4 is schematic diagram of an improved rebreathing isocapnia circuit for spontaneous ventilation illustrated in one embodiment of the invention.

Figure 5 is schematic diagram of an improved rebreathing isocapnia circuit
20 for controlled ventilation illustrated in one embodiment of the invention.

Figure 6 is schematic diagram of an an actively controlled rebreathing circuit for controlled ventilation illustrated in one embodiment of the invention.

Figure 7 is schematic diagram of a non-rebreathing isocapnia circuit for spontaneous ventilation illustrated in one embodiment of the invention.

Figure 8 is schematic diagram of a non-rebreathing isocapnia circuit for controlled ventilation illustrated in one embodiment of the invention.

5 Figure 9A and 9B illustrate diagrams of flow and integrated concentration curves for carbon dioxide.

Figure 10 illustrates with 95% confidence intervals the comparison of measurements of $\dot{V}CO_2$ for the method of the present invention and the Douglas Bag collection method and differences between those measurements.

10 Figure 11 illustrates a comparison of $\dot{V}CO_2$ for the standard bag collection method, a metabolic cart and the method of the present invention.

DETAILED DESCRIPTION OF EMBODIMENTS OF THE INVENTION

The reader is referred generally to the figures with regard to the following
15 description of various embodiments of the invention.

Our improved method:

Circuit:

- a) A rebreathing circuit in which only exhaled gas and no source gas exits
20 from the circuit, as would be the case with
- i) a circle circuit,
 - (1) patient breathing spontaneously or mechanically ventilated,
 - (2) SGF much less than \dot{V}_E , for example SGF is less than half of \dot{V}_E ,

ii) Magill circuit

(1) Patient breathing spontaneously

(2) Ventilated patients: The Magill circuit (figure 1) was designed for

spontaneously breathing patients only as it was felt that the

5 efficiencies of the circuit vis a vis conservation of SGF could not be

obtained with manual-assisted or mechanical ventilation (1). We

describe a modification of the Magill breathing circuit that will

provide all of the benefits with respect to calculation of gas flux

during mechanical ventilation. The circuit (figure 3) consists of a Y-

10 piece (47) with an opening to the patient (35) and inspiratory (38)

and expiratory (36) limbs, a pressure relief valve at the end of the

expiratory limb (37), a port for entry of SGF (39), and a gas reservoir

bag (40) — components of the Magill system used for spontaneous

ventilation. For controlled ventilation, the gas reservoir bag (40) is

15 enclosed in a container with a port (44) for connection to a ventilator

breathing circuit. The pressure relief valve (37) is enclosed in a

container (48) with a port for connection to a ventilator breathing

circuit.

20 On exhalation, the patient breathes out through the patient port (35).

During the initial part of exhalation, the gas reservoir (40) is partially

empty and the resistance to flow along the inspiratory limb (38) is

less than that of the expiratory limb (36) because the higher opening

pressure of the pressure relief valve (37) must be overcome before flow can proceed through the expiratory limb (36). Therefore, during the initial part of expiration, the expired gas enters the inspiratory limb (38), displacing gas in the inspiratory limb (38) and from the SGF (39) into the gas reservoir (40). When the gas reservoir (40) fills, the pressure in the circuit increases above the opening pressure of the pressure relief valve (37) and the remainder of the expired gas is directed down the expired limb (36) displacing the gas out of the expired limb through the pressure relief valve (37) to the ventilator breathing circuit from where it is eventually vented to atmosphere through the expiratory port (49). The SGF continues to flow towards the patient down the inspiratory limb (38), displacing previously exhaled gas into the expiratory limb (36).

During inhalation, the balloon valve (43) occludes the ventilator circuit expiratory port (49) and a volume of gas equal to a tidal volume is delivered by the ventilator (42) into the ventilator circuit (46) and hence into the SGF gas reservoir box (41), thereby displacing a volume equal to the tidal volume from the SGF gas reservoir (40) into the inspiratory limb of the Magill circuit (38). The SGF continues to flow towards the patient down the inspiratory limb (38). The net tidal volume of the patient is equal to the volume displaced from the gas reservoir (40) plus the SGF multiplied by the duration of

inspiration. Because the pressures on both sides of the Magill pressure relief valve (37) are equal during inspiration, the differential pressure provided by the "opening pressure" of the valve (37) keeps it closed during inspiration.

5

(3) the volume of the inspiratory limb is greater than or equal to [(SGF x expiratory time) + the anatomical dead space]; the breathing bag volume is greater than [the largest expected tidal volume - (SGF x inspiratory time)],

10

(4) $SGF \leq 0.7 \times \dot{V}_E$

iii) The rebreathing isocapnia circuit:

15

(1) Patient breathing spontaneously (Fisher rebreathing isocapnia circuit, Figure 4). Circuit consists of a Y piece with patient port (58), and inspiratory limb of Y piece (60) with a one way inspiratory valve (59) and an expiratory limb of Y piece (61) with a one way expiratory valve (53). The inspiratory limb is connected to SGF (51) and a gas reservoir (52). The expiratory limb leads to an expiratory gas reservoir (56). The expiratory gas reservoir (56) has a port opening to atmosphere (57). Between the expiratory limb and the inspiratory limb, distal to the inspiratory (59) and expiratory (53) valves, is a bypass limb (62) that contains a one-way valve (54) with an opening pressure approximately 1.5 cm H₂O greater than the inspiratory (53)

20

and expiratory (59) valves; the direction of opening of the one-way valve in the bypass limb (62) is from expiratory limb to the inspiratory limb.

5 (2) Patient ventilated: The rebreathing isocapnia circuit was described for spontaneously breathing subjects, and its use with ventilated subjects was not contemplated. Accordingly, to use the circuit for controlling \dot{V}_A and measuring gas flux during controlled
10 ventilation, we describe a new rebreathing isocapnia circuit suitable for use with mechanically ventilated subjects. Referring to figure 5: The circuit consists of a Y piece with patient port (58), and inspiratory limb of Y piece with a one way inspiratory valve (78) and an expiratory limb of Y piece with a one way expiratory valve (77). The inspiratory limb is connected to a SGF (66) and a gas reservoir
15 (67). The expiratory limb leads to an expiratory gas reservoir (69). The expiratory gas reservoir (69) has a one way valve (81) at the port where expired gases are vented from the expired gas reservoir (71) which allows gas to exit the expiratory gas reservoir but not enter it. Between the expiratory limb and the inspiratory limb, distal to the
20 inspiratory (78) and expiratory (77) valves is a bypass limb that contains a one-way valve (65) with an opening pressure of the valve approximately 1.5 cm H₂O greater than valves in the inspiratory limb of the Y piece (78) and the expiratory limb of the Y piece (77); the

direction of opening of the one-way valve in the bypass limb (65) is from the expiratory limb to the inspiratory limb. The inspiratory and expiratory limbs are extended by tubing of variable lengths, (64) and (72) respectively. The inspiratory (67) and expiratory (69) reservoirs are enclosed in a box with 3 ports: one port (79) communicates with the box; one port (80) communicates with the interior of the SGF reservoir only; one port (70) communicates with the expiratory gas reservoir. The SGF reservoir (67) is continuous with the inspiratory limb (64) of the circuit. The expiratory gas reservoir (69) is continuous with the expiratory limb of the circuit (72) and has a port (71) through which expired gas exits the expired gas reservoir and enters the box. A ventilator (73) a mushroom valve (74) synchronized to occlude the ventilator circuit expiratory port (75) during the inspiratory phase, is attached to the box ventilator port (79) such that, during the inspiratory phase, the tidal volume of the ventilator is discharged into the box (68). This will displace an equal volume from the gas reservoirs in the box. As the valve in the bypass limb (65) has a greater opening pressure than the inspiratory valve (78), the inspiratory reservoir (67) will be compressed in preference to the expiratory reservoir (69). When the inspiratory reservoir is collapsed, the remainder of the tidal volume will result from compression of the expiratory reservoir (69) and displacement of gas through the bypass limb and valve (65) and inspiratory valve (78) to

the patient. The total tidal volume will be equal to the volume displaced from the inspiratory reservoir (67) plus the volume displaced from the expiratory reservoir (69) plus the SGF multiplied by the time during inspiration.

5

During exhalation, balloon valve (74) is deflated, opening the expiratory port of the ventilator circuit (75) to atmosphere and the expiratory reservoir bag to atmosphere via port (71), thus allowing exhaled gas to flow past the expiratory one-way valve (77) down the expiratory limb (72) into the expiratory reservoir (69). SGF flowing into port (66) is directed down the inspiratory limb (64) to the SGF reservoir (67). Gas displaced in the box (68) by expansion of the SGF reservoir (67) and the expiratory gas reservoir (69) is displaced from the box via the ventilator expiratory port (75).

10

15

(4) SGF is less than or equal to $\dot{V}_E - \dot{V}_{Dan}$.

iv) Non-rebreathing isocapnia circuit:

(1) Spontaneous ventilation (as per Fisher patent, see figure 7)

20

The subject breathes in and out through port (1). Upon expiration one way valve (2) opens and allows expired gas to leave the circuit. Simultaneously, one way valve (4) is forced shut and allows fresh gas reservoir (3) to fill up with pressurized gas from gas source (5). Upon inhalation, one way valve (2) is forced closed and one way

valve (4) is opened, drawing in fresh gas stored in the reservoir (3). If the volume in the reservoir is insufficient for a single tidal volume, the residual volume of the breath is drawn from demand valve (6), connected to a pressurized gas source of CO₂. The preferred concentration of this gas source is arterial PCO₂ to maintain isocapnia.

(2) Controlled ventilation (as in dog paper with Laerdal bag, see figure 8)

During controlled ventilation the subject breathes through port (1). Non-rebreathing valve (3) forces expired gas through port (2). During inspiration gas is inspired from the self inflating bag (4) using a mechanical force to drive the gas through non-rebreathing valve (3). One way valve (5) ensures that all the gas within the bag is forced through valve (3) only. Simultaneously, fresh gas from pressurized source (7) fills up the fresh gas reservoir (6).

During expiration the bag is allowed to self-inflate with gas stored in fresh gas reservoir. If the volume stored in the reservoir is insufficient for a single tidal volume, the residual volume of the bag is made up of gas drawn through low pressure valve (8) from a pressurized source (9), ideally containing arterial concentrations of CO₂ to maintain isocapnia.

iii) Balloon valve circuit

(1) Spontaneous ventilation (see figure 6)

Patient breathing spontaneously (balloon isocapnia circuit, Figure 6).

5 Circuit consists of a Y piece with patient port (100). Inspiratory limb consists of a balloon valve (108), connected to SGF (109) and a gas reservoir (110). Expiratory limb consists of a balloon valve (107), leads to an expiratory gas reservoir (119), which has a port opening to the atmosphere. A tank of compressed air (106) flows through
10 solenoid valves (104) to open or close balloon valves (108 and 107).

The solenoid valves are controlled electronically by a computer (103).

A pressure transducer (102) connected to the mouthpiece (101) measures when the fresh gas reservoir has been fully collapsed. A
15 computer receiving the signal (103) sends a signal to solenoid valve (104) to close inspiratory valve (108) and open expiratory valve (107).

The fresh gas flow (109) continuously fills fresh gas reservoir (110).

Henceforth, all of the above circuits, under conditions suitable for measuring flux
20 of gas using SGF, F_{sx} , and F_{Ex} will be referred to collectively as "conditional breathing circuits, or CBC".

For all CBC, we calculate the flux of gas x by multiplying SGF (as read from the gas flow meter as set by the anesthesiologist) by the difference between the expired gas concentration of x (F_{Ex}) and the gas concentration of x being delivered into the circuit (F_{Sx}) (which is also set by the anesthesiologist). Thus, for any gas x
5 (other than CO_2 if a circle anesthetic circuit contains a CO_2 absorber in the circuit, see below):

$$\text{Flux of gas } x = \text{SGF} (F_{Sx} - F_{Ex}) \quad (1)$$

10 The advantage of using equation (1) to calculate flux, is that a) SGF is set by the anesthesiologist, is precisely known, and is constant; b) F_{Sx} is set by the anesthesiologist and is precisely known and is constant. This contrasts with the inspired concentration measured at the mouth, F_{Ix} , which may vary throughout inspiration.

15

Rationale for new approach:

The principle will be illustrated with a circle circuit (see figure 2), but similar considerations can be made for all of the circuits and conditions outlined below.

20 With a patient breathing via a circle circuit, and SGF set substantially lower than \dot{V}_E , for example one half \dot{V}_E , only exhaled gas leaves the circuit. Therefore, at low SGF, all of the SGF can be considered "fresh gas" and will contribute to alveolar ventilation. Therefore we consider $\text{SGF} = \dot{V}_A$. The rest of the gas

entering the alveoli is rebreathed gas. Another way of looking at this is to consider the patient to be an additional gas compartment of the circuit; we can then consider the mass balance as it applies to the circuit alone. From the perspective of the circuit, we no longer need to deal with the complex gas concentrations and flows that occur at the circuit-patient interface as in the previous art. We deal only with the gas concentrations and flows that occur with respect to gases entering and leaving the *circuit*. The volume of a gas entering the circuit ($SGF \times F_{Sx}$) is equal to that of the gas eliminated from the circuit ($SGF \times F_{Ex}$) plus that of the gas absorbed or eliminated by the patient ($SGF [F_{Sx} - F_{Ex}]$).

10

In summary, our method can be stated as: volume of gas x entering or leaving a patient = volume of gas x entering the circuit – volume of gas x leaving the circuit = $SGF \times F_{Sx} - SGF \times F_{Ex}$

15 Or Flux of gas $x = SGF (F_{Sx} - F_{Ex})$

The prior art does not indicate that this is sufficient to calculate the uptake and elimination of gases during anesthesia and continues to require the flow-averaged concentrations of gas during inspiration and expiration measured at the patient-circuit interface, i.e., at the mouth of the patient, to calculate gas flux. This is evidenced by recent articles, for example by Wissig (2) and Rietbrock (3) which are accepted as reflecting the state of the art by an editorial in the British Journal of

20

Anaesthesia by Bouillon and Shafer (4), the latter being recognized in the anesthesia profession as a world authority in the field of pharmacokinetics

Advantages of our approach over previous methods:

5

The advantages of our method in calculating the flux of a gas x would apply with the use of any circuit in which the concentration of gas x in SGF entering the circuit is known, SGF is less than or equal to $\dot{V}_E - \dot{V}_{Dn}$ and the circuit is such that the difference between \dot{V}_E and SGF is made up of reserve gas, the concentration of x in the reserve gas being substantially that in the alveoli at end exhalation; an example of reserve gas of suitable composition is previously exhaled gas. Examples of such circuits are the Magill circuit (Mapleson A configuration, referred to as the 'Magill circuit'), the circle anesthetic circuit, and the rebreathing and non rebreathing isocapnia circuit (Fisher patents).

15

The circle anesthetic circuit is the most commonly used circuit during anesthesia. All anesthetic machines allow precise setting of SGF and its composition. Therefore, SGF and F_{Sx} are precisely known. Machines to continuously read out concentrations of such gases as CO_2 , O_2 , N_2O , and anesthetic vapors have been widely available for over a quarter of a century and are routinely available with all modern anesthetic systems. With our method, the flux of any gas x can be readily determined by multiplying SGF by $(F_{Sx} - F_{Ex})$. Oxygen and CO_2 analyzers are compact and readily available outside of the operating room. The Mapleson A

circuit and the rebreathing isocapnia circuit (Fisher) are inexpensive, easy to assemble, and can be applied outside of the operating room. The method of measurement of gas flux can be applied to measuring O₂ consumption, CO₂ production, pharmacokinetics of inhaled anesthetics and other drugs, and cardiac
5 output (the latter the subject of a separate patent application).

1) Measuring alveolar ventilation:

\dot{V}_A ($\dot{V}_E - \dot{V}_{Dan}$) is very difficult to measure for two reasons.

- a) First, \dot{V}_E is difficult to measure. To do this, one requires a device to
10 measure flow such as a pneumotachometer and machine intelligence to integrate the flow signal with respect to time and calculate volume. Whereas minute ventilation can be calculated in mechanically ventilated subjects from ventilator settings, it must be measured directly in spontaneously breathing subjects. All flow sensing devices have drawbacks:
- 15 i) Pneumotachometers based on pressure differentials are expensive and cumbersome to use outside a laboratory setting. They are affected by changes in gas temperature and composition; condensation from expired gas changes their calibration and requires addition of external heaters which introduces its own errors at high flow rates. They are also
20 subject to drift, in part for the reasons just given, and require, or would benefit from, frequent recalibration.
- ii) Electronic turbines use low resistance rotating vanes to measure volumes. Their major drawbacks include friction and inertia of the

vane, resulting in a lag before flow is detected and continued spin after flow has ceased

5 iii) Pitot tubes measure the pressure flowing against a series of small tubes mounted at 90 degrees to the direction of gas flow. They are notoriously alinear and sensitive to changes in gas composition, as occurs during breathing.

10 iv) Hot-wire (mass flow) anemometers rely on the cooling effect caused by laminar gas flow. However, they require sophisticated electronics and difficult calibrations to maintain accuracy.

15 b) Second, anatomical dead space, \dot{V}_{Dan} , is difficult to measure and estimates based on body weight are inaccurate. Measurement of anatomical dead space requires particular equipment and monitors and is prohibitively difficult to do outside of a specialized laboratory.

20 Our method: The alveolar ventilation can be known precisely by simply reading the flow setting on the flowmeter, which is a precisely calibrated instrument.

Therefore, our method

- does not require the expense of pneumotachometers
- is not affected by the inaccuracies inherent in the use of pneumotachometers

- circumvents the complexity of measuring minute ventilation, integration of flow, and the requirement for precise rapid measures of gas concentrations (see below).
- circumvents the complexity of measuring anatomical dead space,
- 5 • is just as accurate for spontaneously breathing subjects as it is with ventilated subjects.

2) The previous art requires that measurements of flow be synchronized with measurements of gas concentrations in order to calculate the breath-by-breath
10 flux of gas. The inspired gas concentration while breathing on a rebreathing circuit varies continuously throughout the breath. The net inspired volume of gas x is a flow-weighted average of the inspired gas concentration. To be able to calculate this accurately, a very rapidly responding gas analyzer and precise synchronization to the flow signal are required. This is very difficult in a
15 laboratory setting, and even more difficult in a clinical setting. At higher flows, small errors in synchronization will give large errors in gas flux. Each error is then multiplied by the number of breaths.

With our method, only the average expired concentration of gas is required.
20 This allows the use of much less expensive and slower portable gas analyzers. During any testing procedure, gas concentrations in the gas mixture delivered to the circuit are set by the person doing the test. When breathing through a

rebreathing circuit and when SGF limits \dot{V}_A , gas flux calculations are simplified to $SGF \times (F_{Sx} - F_{Ex})$.

3) The calculation with our method is more robust and accurate than that with the prior art (see data).

a) With our method, SGF, F_{Sx} , and F_{Ex} are precisely known. With the prior art, the errors in measuring flow, gas concentrations, and synchronization of flow and concentration signals, are additive.

b) Our method is independent of \dot{V}_E and extent of rebreathing. With the prior art, inaccuracy of measurement of gas flux increases as \dot{V}_E and the extent of rebreathing increases.

Applications for gas flux measurement:

1) Oxygen flux:

At present, there is no practical means to follow oxygen consumption intra- and post-operatively in the recovery room or intensive care area. Metabolic carts that perform this function require the additional means to measure gas flow and complex machine intelligence. Such machines typically cost in excess of US\$25,000 each, making it prohibitively expensive for routine use.

Our method would allow continuous and intermittent measurements of oxygen consumption in ventilated as well as spontaneously breathing patients who are in the operating room. Outside of the operating room, any of the CBC

described above can be used to calculate oxygen consumption by means of a simple calculation and without the cost of additional hardware.

a) In the operating room

5

- Oxygen consumption is an important index of health. Optimization of oxygen consumption has been shown to decrease post-operative mortality and morbidity, and improve organ function and survival in patients undergoing intensive care after trauma, shock, sepsis and major surgery.

10

- Increases in oxygen consumption would be a very sensitive early sign of malignant hyperthermia (MH), a rare but devastating condition triggered by anesthesia and consisting of sudden explosive hypermetabolism, increased oxygen consumption, CO₂ production, and high body temperature. Currently, all anesthetized patients are monitored with temperature probes. Increases in oxygen consumption would be a much earlier sign of MH than increases in body temperature. Early detection and thus early intervention would allow MH to be aborted before the fulminant stage, averting much morbidity and saving many lives. Furthermore, monitoring oxygen consumption with our method would be a much less expensive than with electronic temperature probes which are expensive and, because they have to be sterilized between patients, have short life spans.

20

- Closed circuit anesthesia provides maximum efficiency of use of an anesthetic gas. At present, determining the O₂ flow for closed circuit anesthesia requires "trial and error" adjustments of the O₂ flow as indicated by the trend in the extent of expiratory recoil of the ventilator bellows. The exact flow of oxygen is almost impossible to ascertain and, as a result, there is constant oscillation in the oxygen flow. The required flows of such other gases as N₂O and anesthetic vapor are impossible to set without knowing the total body absorption of the gas. Attempting to set the anesthetic flow rates by trial and error results in oscillation of anesthetic depth due to the long delays between changes in source gas concentrations and the development of a steady state gas concentration.

Knowing gas flux would allow for more accurate setting of source gas flows, a shorter feed-back loop, and thus more stable alveolar gas concentrations during anesthesia as well as less frequent adjustments of source gas concentration and flow. Patients would benefit by receiving the intended and appropriate doses of anesthesia.

With our method, the O₂ flow is readily determined as the

$$\text{O}_2 \text{ flow} = \text{O}_2 \text{ flux} = \text{O}_2 \text{ consumption (in steady state)} = \text{SGF} \times (\text{F}_i\text{O}_2 - \text{F}_E\text{O}_2)$$

where F_{SO_2} is the concentration of O_2 in the source gas and F_{EO_2} is the concentration of O_2 in expired gas.

Calculating flux of any gas x when breathing via a circle circuit with low SGF
5 and with CO_2 absorber in place

i) When x is CO_2 , and rebreathing of CO_2 is prevented by means of a CO_2 absorber in the circuit, equation (1) cannot be used and one needs to know the \dot{V}_{Dan} to calculate \dot{V}_A (as $\dot{V}_A = \dot{V}_E - \dot{V}_{Dan}$). Then, CO_2 flux
10 $= \dot{V}_A \times (F_{ECO_2} - F_{ICO_2})$, but since $F_{ICO_2} = 0$, CO_2 flux $= \dot{V}_A \times F_{ECO_2}$.
Our method does not confer any benefits to the calculation of the flux of CO_2 when a rebreathing circuit includes a CO_2 absorber.

ii) For a rebreathing circuit that includes a CO_2 absorber, or for any CBC,
15 and when x is any other gas:

$$\text{flux_of_gas_x} = \text{SGF}(F_{Ex} - F_{Sx}) + (\dot{V}_E - \dot{V}_{Dan} - \text{SGF})(F_{Ex} - F_{RBx})$$

(2)

where F_{Sx} is the concentration of x in the SGF entering the circuit and
20 F_{RBx} is the concentration of x in the expired limb of the circuit before the gas passes through the CO_2 absorber and mixes with gas coming out of the flowmeter.

Since $F_{Ex} = F_{RBx}$,

$$\text{Flux of } x = \text{SGF} (F_{Ex} - F_{RBx}) \quad (3)$$

5 Note that the actual inhaled concentration of x is the flow-weighted average concentration of x in the mixed SGF and rebreathed gas. However, with our method, the complex measurement and calculation of the inhaled volume of x are unnecessary. To measure the flux of an anesthetic, the SGF is multiplied by the difference between the end tidal and SGF concentrations of x . The continuous measure of flux of any gas
10 by this method allows one to easily calculate the changes in anesthetic gas absorption, and hence vaporizer setting required to maintain the same end tidal concentrations of anesthetic for any SGF, including that equal to O_2 consumption, which is defined as "closed circuit"
15 anesthesia.

Examples of benefits of applying these methods:

- N_2O is an anesthetic gas used in over 95% of anesthetic procedures. It is
20 used in ratios of 1:1 to 2:1 with O_2 . It is relatively insoluble in blood and body tissues so that when used as an anesthetic, the tissues saturate quickly with small volumes of the gas and the tissue uptake of N_2O approaches 0. Nevertheless, it is impossible with present art to know

when tissues become saturated. Therefore, N₂O flow settings are not commonly changed throughout the operation. N₂O is an environmental pollutant breaking down the ozone layer and costs 10 times as much as O₂. The continued flow of N₂O at levels greater than the rate of absorption is not only a waste of N₂O, but also wastes the anesthetic vapor that is washed out of the circuit with the excess N₂O.

- Knowing the exact flux of N₂O as with our method would allow the anesthesiologist to turn down, or off, the N₂O when the tissues become saturated with it (i.e., when the flux = 0). One would expect that the tissues will become saturated in about 5 minutes. For a 2 hour anesthetic, this would represent a 95% saving; the longer the operation, the greater the saving.

- Halothane, isoflurane, sevoflurane, and desflurane are inhalation anesthetic vapors. They have various costs ranging from a few cents per milliliter for halothane and isoflurane to about one dollar per milliliter for sevoflurane and desflurane. They are also environmental pollutants breaking down the ozone layer. These vapors enter the anesthetic circuits as part of SGF at various concentrations set by the anesthesiologist. Knowing the rate of absorption of these anesthetic vapors would allow the most efficient use of the anesthetics and the most precise control of the depth of anesthetic.

b) *Outside the operating room:*

5 With our method, a subject breathes spontaneously or is ventilated, via a
CBC as described above, oxygen consumption is calculated as

$$\text{SGF} \times (\text{F}\text{SO}_2 - \text{F}\text{EO}_2)$$

10 where SGF and FSO_2 are deliberately set and therefore known, and FEO_2 is
measured from a rapid O_2 analyzer.

- Oxygen consumption in response to exercise is an important measure of physical fitness. This is a standard test performed routinely around the world by cardio-respiratory assessment laboratories to test exercise capacity, cardio-pulmonary fitness and nutritional status in patients as well as in athletes.
- Oxygen consumption is one of the measures required to measure cardiac output by the Fick method.

20 Figures 9A, 9B, 10, and 11 illustrate flow and concentration curves for comparison
to
the "gold standard" of measuring flux (timed collection) to our method.

Particularly Figures 9A and 9B illustrate diagrams of flow and integrated concentration curves for carbon dioxide.

Figure 10 illustrates with 95% confidence intervals the comparison of
5 measurements of $\dot{V}CO_2$ for the method of the present invention and the Douglas
Bag collection method and differences between those measurements.

Figure 11 illustrates a comparison of $\dot{V}CO_2$ for the standard bag collection method,
a metabolic cart and the method of the present invention.

10

As many changes can be made to the various embodiments of the invention
without departing from the scope thereof; it is intended that all matter contained
herein be interpreted as illustrative of the invention but not in a limiting sense.

THE EMBODIMENTS OF THE INVENTION IN WHICH AN EXCLUSIVE PROPERTY OR PRIVILEGE IS CLAIMED ARE AS FOLLOWS:

1. A method of calculating the flux of any gas(x) in a CBC circuit for a ventilated or a spontaneous breathing subject,

for example said gas(x) being;

a) an anesthetic such as but limited to;

i) N₂O;

ii) sevoflurane;

iii) isoflurane;

iv) halothane;

v) desflurane;

or the like

b) Oxygen;

c) Carbon dioxide;

or the like

utilizing the following relationships;

$$\text{Flux of gas(x)} = \text{SGF} (F_{\text{SX}} - F_{\text{EX}})$$

wherein

SGF = Source of gas flow into the breathing circuit (CBC circuit) in liters/minute as read from the gas flow meter as set by the anesthesiologist;

F_{SX} = Fractional concentration of gas X in the source gas (which is set by the anesthesiologist);

F_{EX} = Fractional concentration of gas X in the end expired gas as determined by a portable gas analyzer, or the like.

2. A method of calculating the flux of oxygen in a CBC circuit for a ventilated and/or spontaneous breathing subject utilizing the following relationship;

$$\text{Flux of oxygen} = \text{SGF} (F_{S_{O_2}} - F_{E_{O_2}})$$

wherein

SGF = Source of gas flow into the breathing circuit (CBC circuit) in liters/minute as read from the gas flow meter as set by the anesthesiologist;

F_{SX} = Fractional concentration of gas O_2 in the source gas (which is set by the anesthesiologist);

F_{EX} = Fractional concentration of gas O_2 in the end expired gas as determined by a portable gas analyzer, or the like.

3. The method of claim 1 or 2 wherein the CBC circuit is selected from the group consisting of i) a circle circuit; ii) a Magill breathing circuit; iii) an isocapnia circuit, whether breathing or non-breathing (as taught by co-pending Fisher et al), or the like.
4. The method of claim 1 or 2 wherein the CBC circuit is an improved Magill circuit as described herein.
5. The method of claim 1 or 2 wherein the CBC circuit is an improved rebreathing circuit as described herein.

6. The method of claim 1 or 2 wherein the CBC circuit is an improved non-rebreathing circuit as described herein.
7. The method of claim 2 used to determine oxygen consumption in order to measure cardiac output by any known method, such as the Fick method.
8. The method of claim 2 used to determine oxygen consumption in, for example, an operating room setting or the like.
9. The method of claim 2 or 8 used to optimize oxygen consumption.
10. The method of claim 2 or 8 utilized as an early indication of malignant hyperthermia.
11. A method of calculating the flux of any gas other than carbon dioxide, in a CBC circuit with low gas flow of source gas and with a carbon dioxide absorber in place utilizing the following relationship;

$$\text{Flux of gas X} = \text{SGF} (\text{FEX} - \text{FRBX})$$

wherein

SGF = Source of gas flow into the breathing circuit (CBC circuit) in liters/minute as read from the gas flow meter as set by the anesthesiologist;

F_{EX} = Fractional concentration of gas X in the end expired gas as determined by a portable gas analyzer, or the like;

F_{RBX} = Concentration of gas X in the expired limb of circuit before the gas passes through the carbon dioxide absorber and mixes with gas coming from the flow meter.

12. The method of claim 11 used to determine the flux of an anesthetic for example:

- i) N₂O;
- ii) sevoflurane;
- iii) isoflurane;
- iv) halothane;
- v) desflurane,

or the like

13. The method of claim 12 used to determine how much anesthetic is being absorbed by the patient.

14. The method of claim 13 wherein said anesthetic is N₂O.

15. An improved Magill circuit the improvement comprising an inspiratory and expiratory limbs, a pressure relief valve at the end of the expiratory limb, a port for entry of SGF, and a gas reservoir bag, the components of the Magill system utilized for spontaneous ventilation; or alternatively for controlled ventilation, the gas reservoir bag is enclosed in a container with a port for connection to a ventilator breathing circuit, the pressure relief valve being enclosed in a container with a port for connection to a ventilator breathing circuit;

wherein on exhalation, the patient breathes out through the patient port and during the initial part of exhalation, the gas reservoir is partially empty and the resistance to flow along the inspiratory limb is less than that of the expiratory limb because the higher opening pressure of the pressure relief valve must be overcome before flow can proceed through the expiratory limb,

wherein during the initial part of expiration, the expired gas enters the inspiratory limb, displacing gas in the inspiratory limb and from the SGF into the gas reservoir, as the gas reservoir fills, the pressure in the circuit increases above the opening pressure of the pressure relief valve and the remainder of the expired gas is directed down the expired limb displacing the gas out of the expired limb through the pressure relief valve to the ventilator breathing circuit from where it is eventually vented to atmosphere through the expiratory port and the SGF continues to flow towards the patient down the inspiratory limb, displacing previously exhaled gas into the expiratory limb;

wherein during inhalation, the balloon valve occludes the ventilator circuit expiratory port and a volume of gas equal to a tidal volume is delivered by the ventilator into the ventilator circuit and hence into the SGF gas reservoir box, thereby displacing a volume equal to the tidal volume from the SGF gas reservoir into the inspiratory limb of the Magill circuit, the SGF continues to flow towards the patient down the inspiratory limb;

wherein the net tidal volume of the patient is equal to the volume displaced from the gas reservoir plus the SGF multiplied by the duration of inspiration, because the pressures on both sides of the Magill pressure relief valve are equal during inspiration, the differential pressure provided by the "opening pressure" of the valve keeps it closed during inspiration;

assuming that:

(1) the volume of the inspiratory limb is greater than or equal to [(SGF x expiratory time) + the anatomical dead space]; and the breathing bag volume is greater than [the largest expected tidal volume - (SGF x inspiratory time)],

(2) $SGF \leq 0.7 \times \dot{V}_E$

16. An improved rebreathing isocapnia circuit comprising a Y piece with a patient port, and inspiratory limb of the Y piece with a one way inspiratory valve and an expiratory limb of the Y piece with a one way expiratory valve; the inspiratory limb being connected to a SGF and a gas reservoir, the expiratory limb leading to an expiratory gas reservoir, the expiratory gas reservoir having a one way valve at the port where expired gases are vented from the expired gas reservoir which allows gas to exit the expiratory gas reservoir but not enter, having disposed between the expiratory limb and the inspiratory limb distal to the inspiratory and expiratory valves a bypass limb that contains a one-way valve with an opening pressure of the valve, being for example approximately 1.5 cm H₂O, greater than the valves in the inspiratory limb of the Y piece and the expiratory limb of the Y piece; the direction of opening of the one-way valve in the bypass limb being from the expiratory limb to the inspiratory limb, the inspiratory and expiratory limbs being extended by tubing of variable lengths, the inspiratory and expiratory reservoirs being enclosed in a box with 3 ports; one port communicates with the box, one port communicates with the interior of the SGF reservoir only, one port communicates with the expiratory gas reservoir, the SGF reservoir is continuous with the inspiratory limb of the circuit, the expiratory gas reservoir is continuous with the expiratory limb of the circuit and has a port through which expired gas exits the expired gas reservoir and enters the box, a ventilator, a mushroom valve synchronized to occlude the ventilator circuit expiratory port during the inspiratory phase attached to the box ventilator port such that during the inspiratory phase, the tidal volume of the ventilator is discharged into the box, which will displace an equal volume from the gas reservoirs in the box; as the valve in the bypass limb has a greater opening pressure than the inspiratory valve, the inspiratory reservoir will be compressed in preference to the expiratory reservoir, when the inspiratory reservoir is collapsed, the remainder of the tidal volume will result from compression of the expiratory reservoir and displacement of gas through the bypass limb and valve and inspiratory valve to the patient, the total tidal volume will be equal to the volume

displaced from the inspiratory reservoir plus the volume displaced from the expiratory reservoir plus the SGF multiplied by the time during inspiration; during exhalation, the balloon valve is deflated, opening the expiratory port of the ventilator circuit to atmosphere and the expiratory reservoir bag to atmosphere via the port, thus allowing exhaled gas to flow past the expiratory one-way valve down the expiratory limb into the expiratory reservoir, SGF flowing into the port being directed down the inspiratory limb to the SGF reservoir, wherein gas is displaced in the box by expansion of the SGF reservoir and the expiratory gas reservoir is displaced from the box via the ventilator expiratory port; wherein SGF is less than or equal to $\dot{V}_E - \dot{V}_{Dan}$.

17. An improved non-rebreathing circuit, the improvement comprising a balloon valve circuit for spontaneous ventilation of a patient breathing spontaneously, said circuit having a Y piece with a patient port, an inspiratory limb including a balloon valve, connected to SGF and a gas reservoir, an expiratory limb consisting of a balloon valve leading to an expiratory gas reservoir, which has a port opening to the atmosphere, a tank of compressed air flows through solenoid valves to open or close the balloon valves, the solenoid valves being controlled electronically by a computer, a pressure transducer connected to a mouthpiece for measuring when the fresh gas reservoir has been fully collapsed, the computer for receiving the signal and sending a signal to the solenoid valve to close the inspiratory valve and open the expiratory valve, the fresh gas flow continuously filling the fresh gas reservoir.

18. The method of claims 1, 2, or 11 used to calculate the rate of elimination of a gas X for any input total gas flow utilizing the following further relationships;

wherein the rate of elimination of gas X = the input total gas flow (multiplied by) $F_{EX} - F_{IX}$;

wherein F_{EX} is defined above and F_{IS} is the concentration of X in inspired gas.

19. The method of any previous claim wherein said method is incorporated in an algorithm spreadsheet, formula or the like contained within software which is capable of running on a computing device, or is installed therein.

Figure 1: Schematic diagram of Magill circuit, Mapleson A configuration

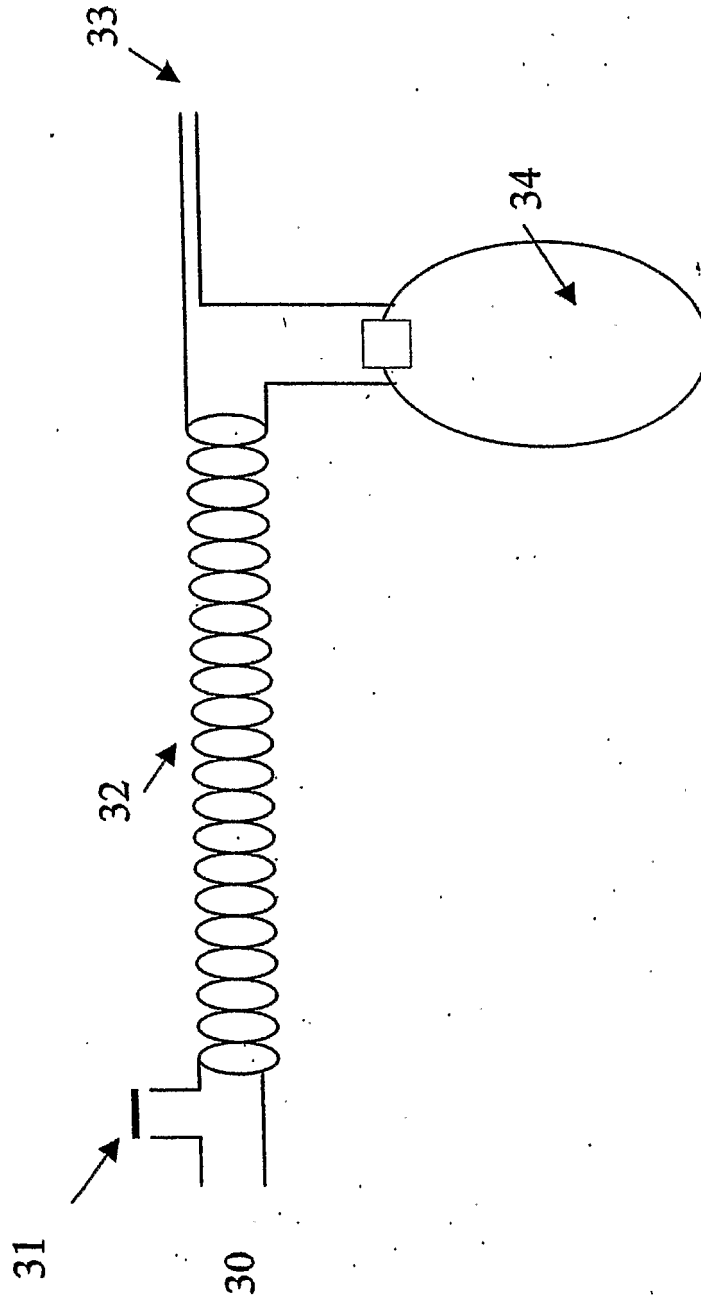

Figure 2. Schematic diagram of circle anaesthetic circuit

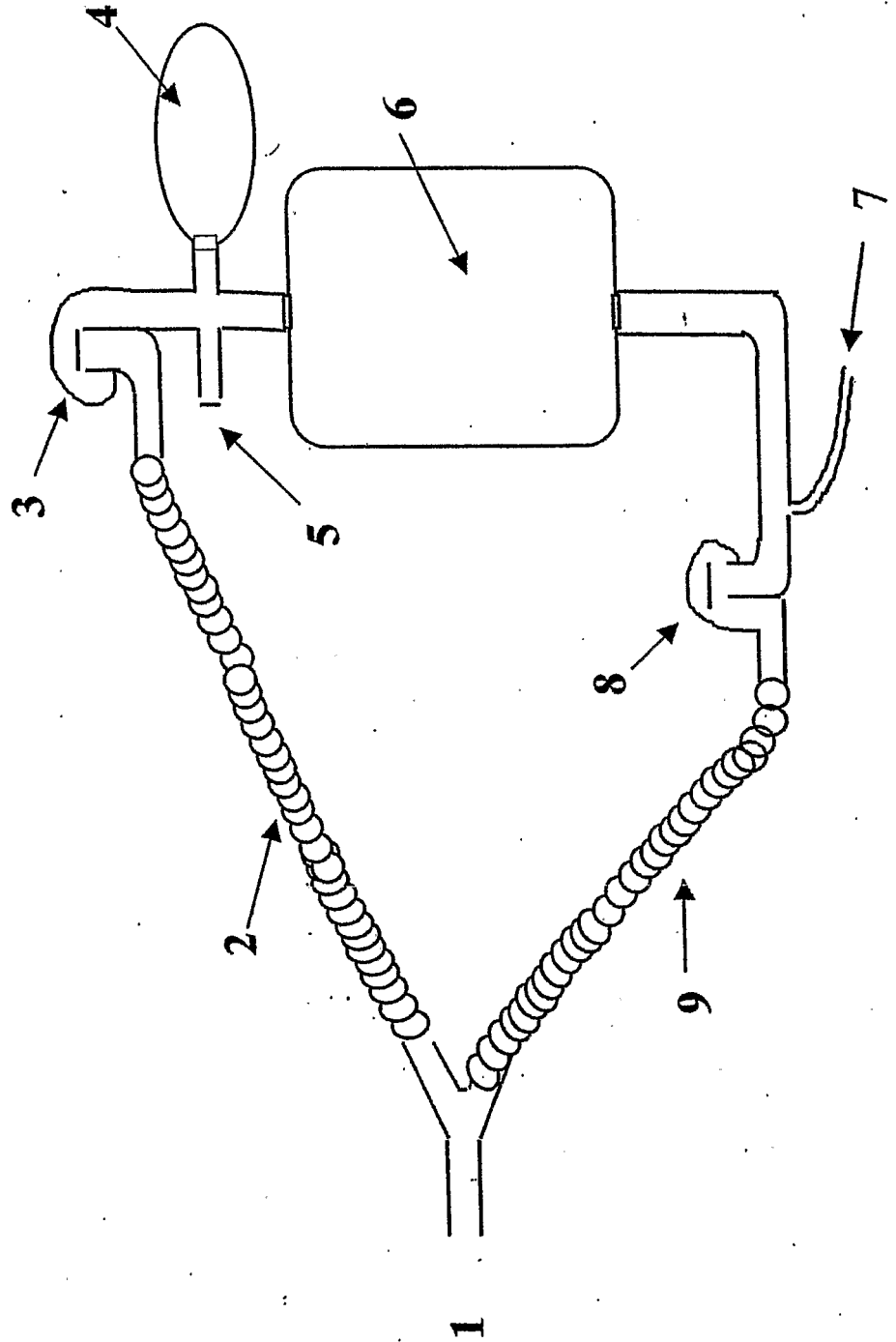

Figure 4: Schematic diagram of rebreathing isocapnia circuit for spontaneous ventilation

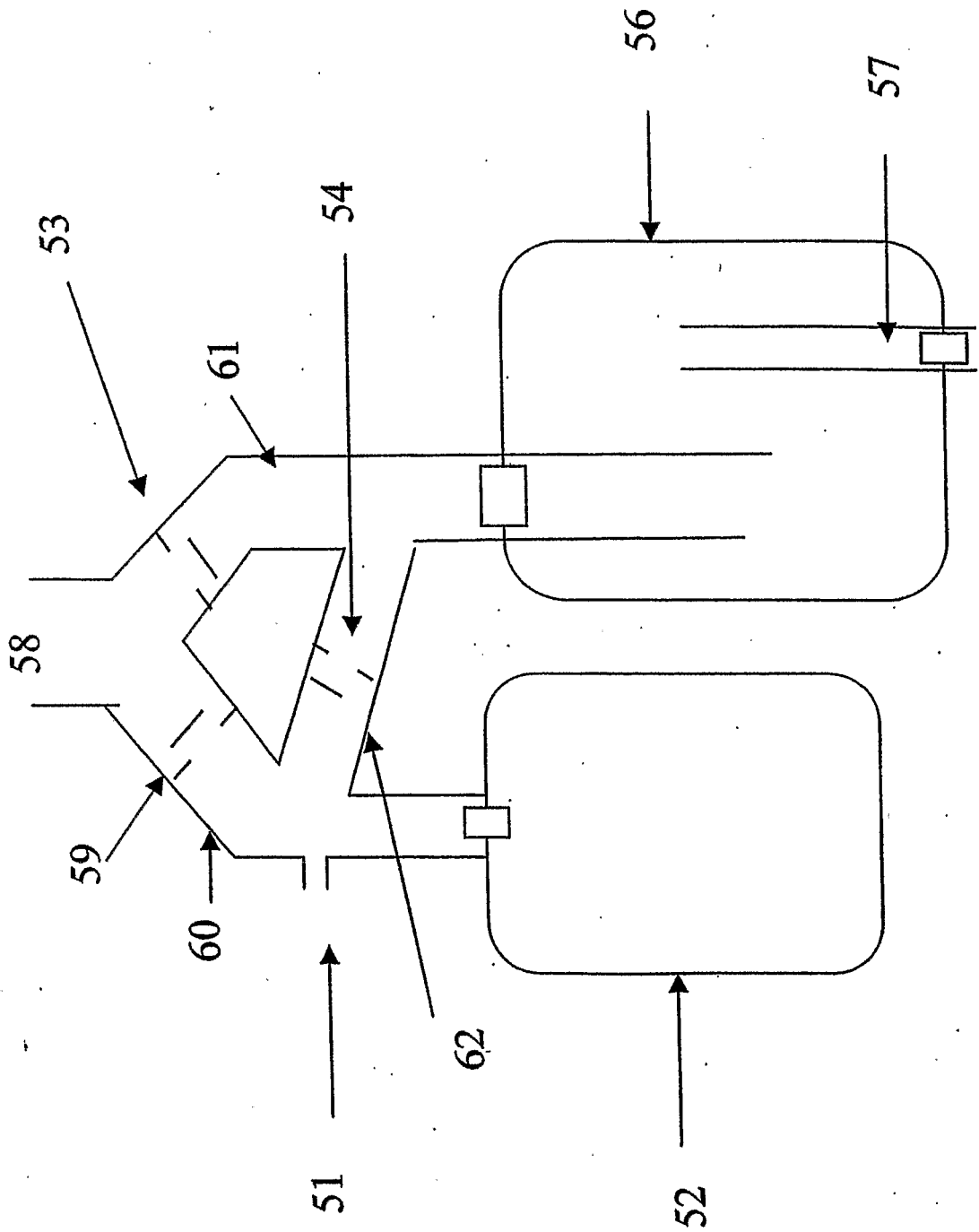

Figure 5. Schematic diagram of rebreathing isocapnia circuit for controlled ventilation

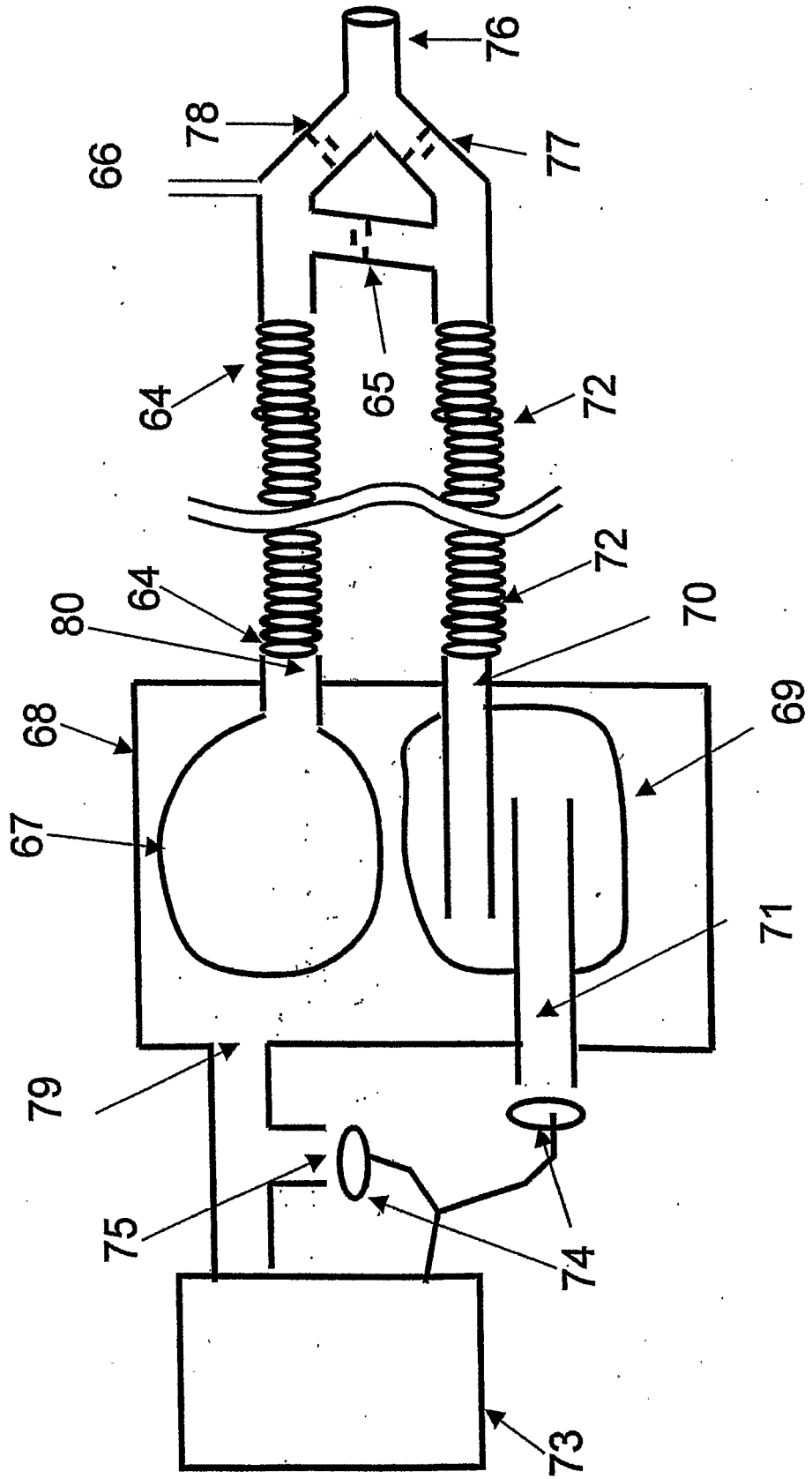
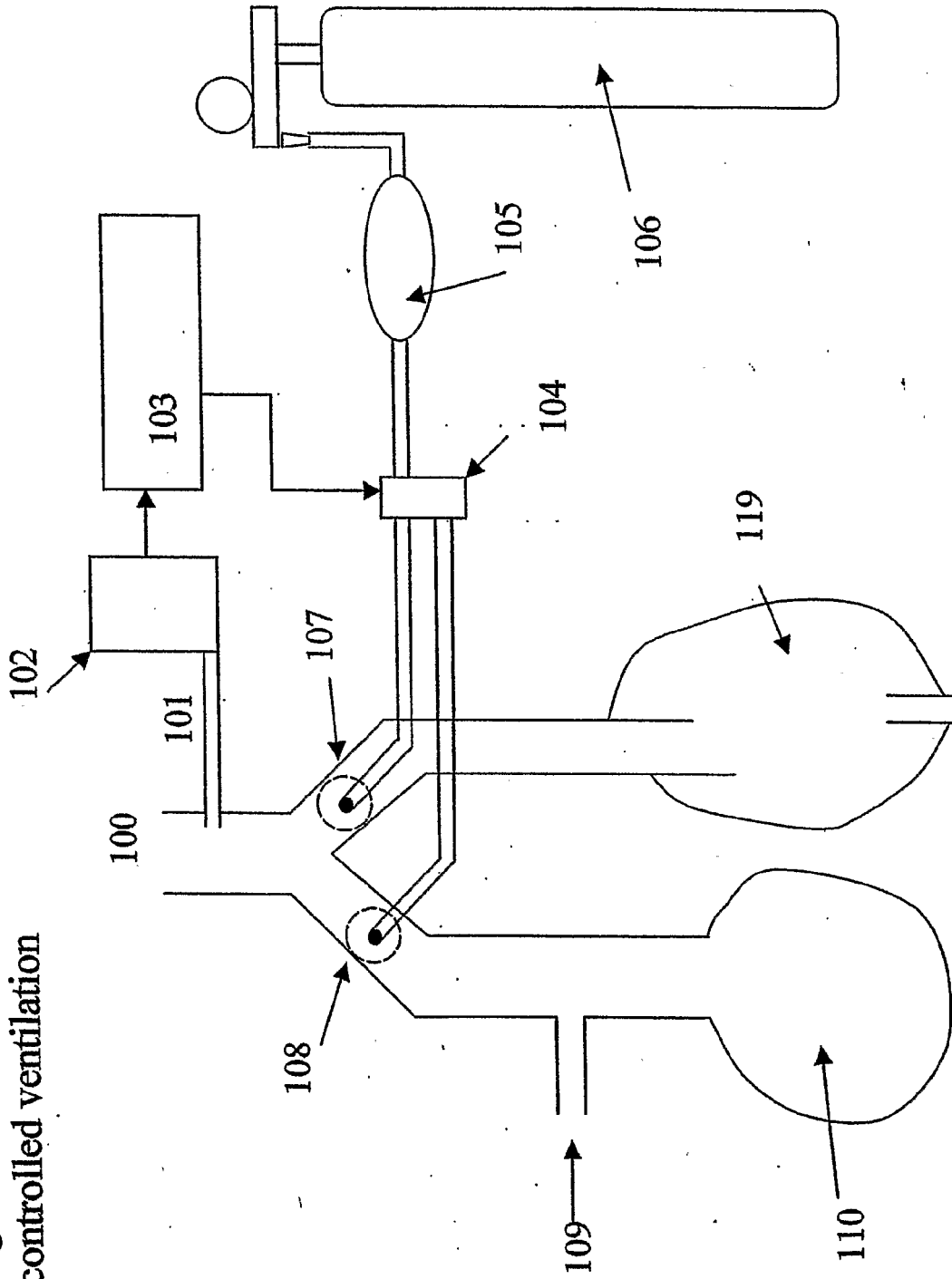

Figure 6. Schematic diagram of actively controlled rebreathing circuit for controlled ventilation



* Logic board algorithm: 1. positive pressure, balloon deflated. 2. Next negative pressure-> inflate balloon. 3. Next pressure < -2 cm H2O -> deflate balloon. 4. Next positive pressure, reset to 1. Note: one way valve can be replaced by second balloon valve that is inflated in 1, deflates in 2 and inflates in 3, making the method potentially even more accurate.

Figure 7. Schematic diagram of non-rebreathing isocapnia circuit for spontaneous ventilation

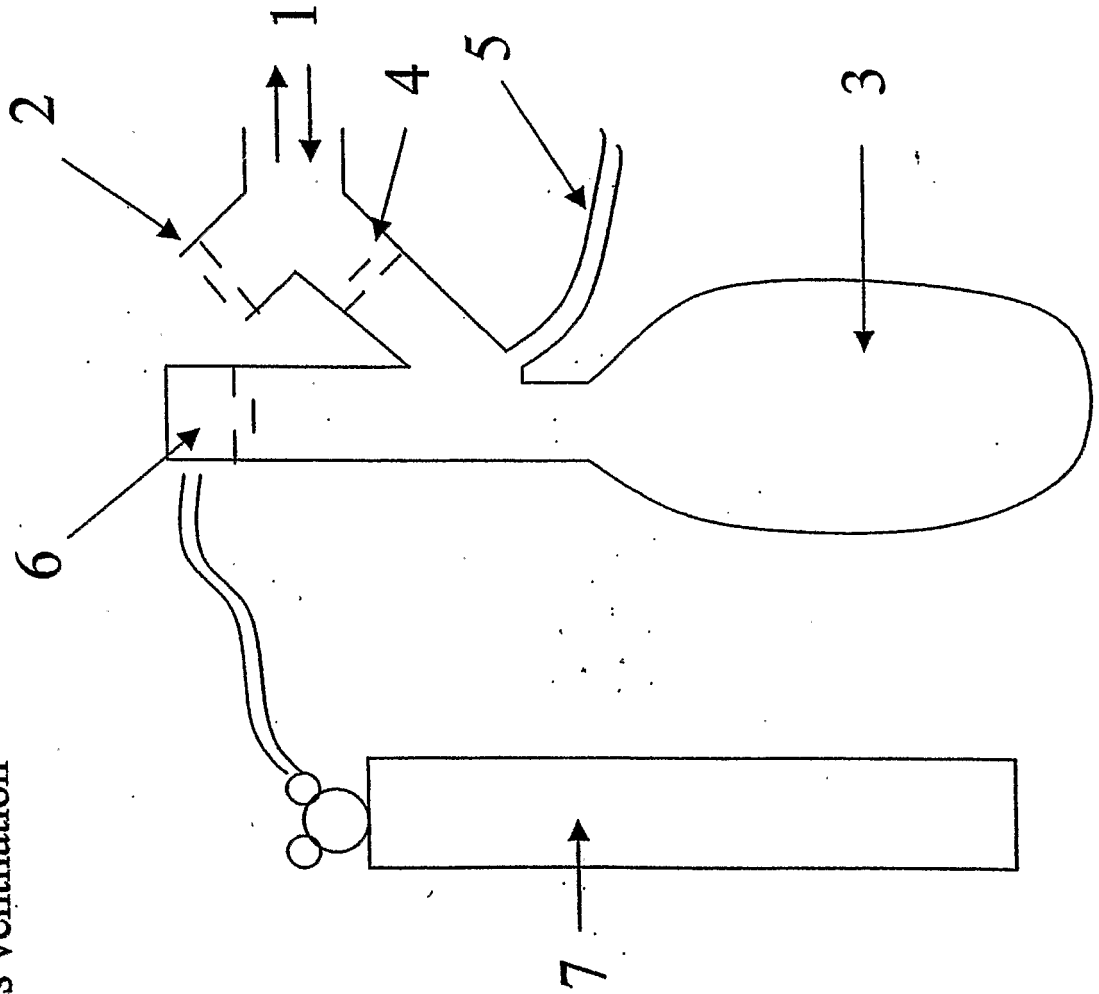

Figure 8. Schematic diagram of non-rebreathing isocapnia circuit for controlled ventilation

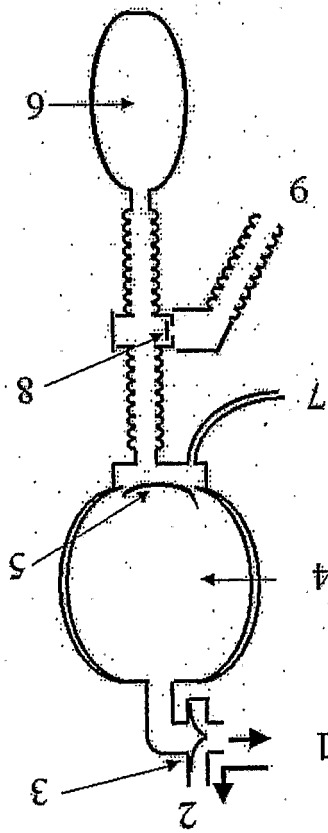

FIGURE 9A

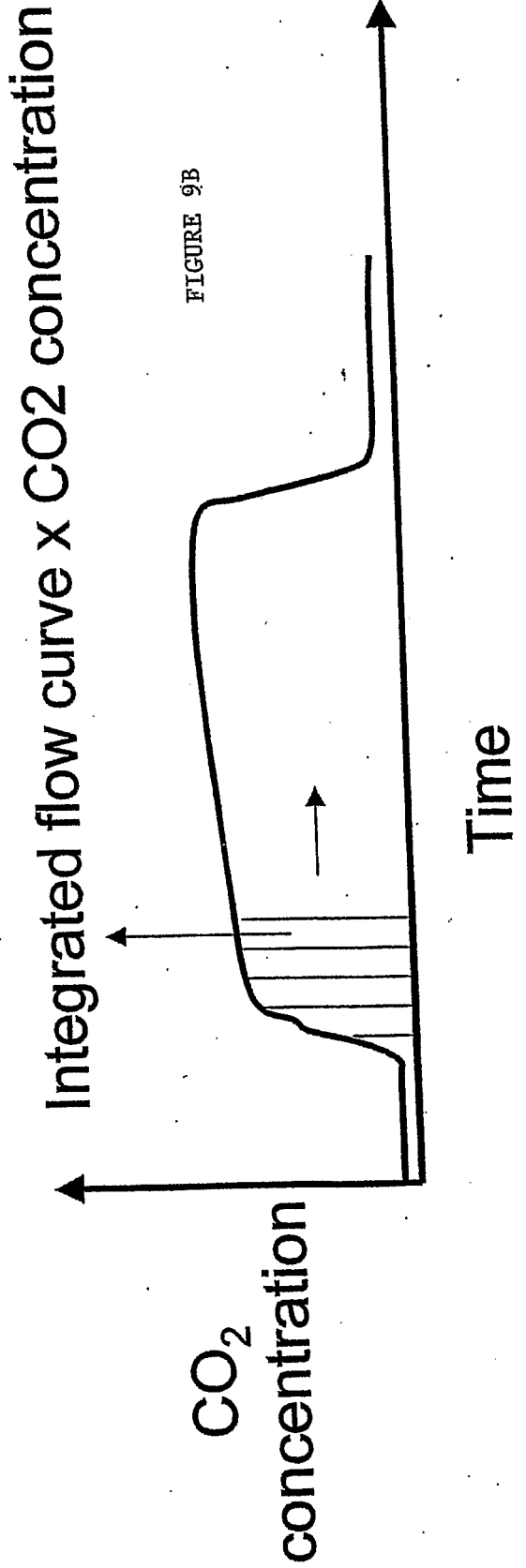
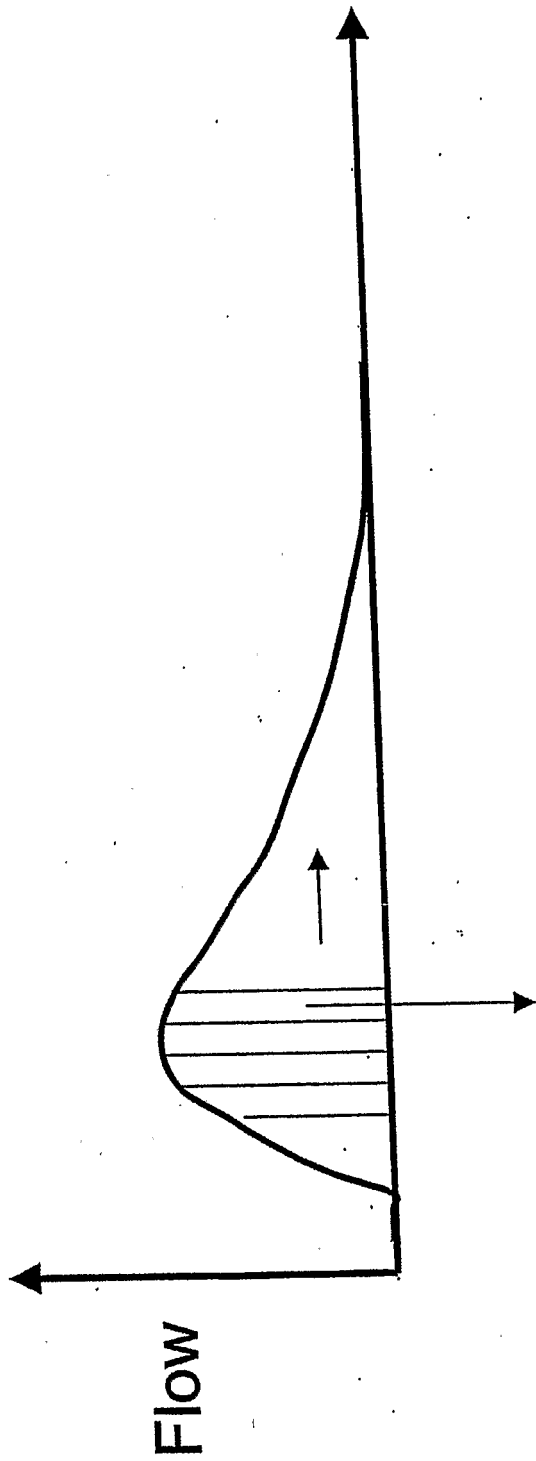

FIGURE 9B

Figure showing the 95% confidence intervals of our new method for measuring \dot{V}_{CO_2} . X-axis shows average \dot{V}_{CO_2} or (Douglas bag \dot{V}_{CO_2} + new method) / 2
Y-axis shows deviation of new method from Douglas bag collection.

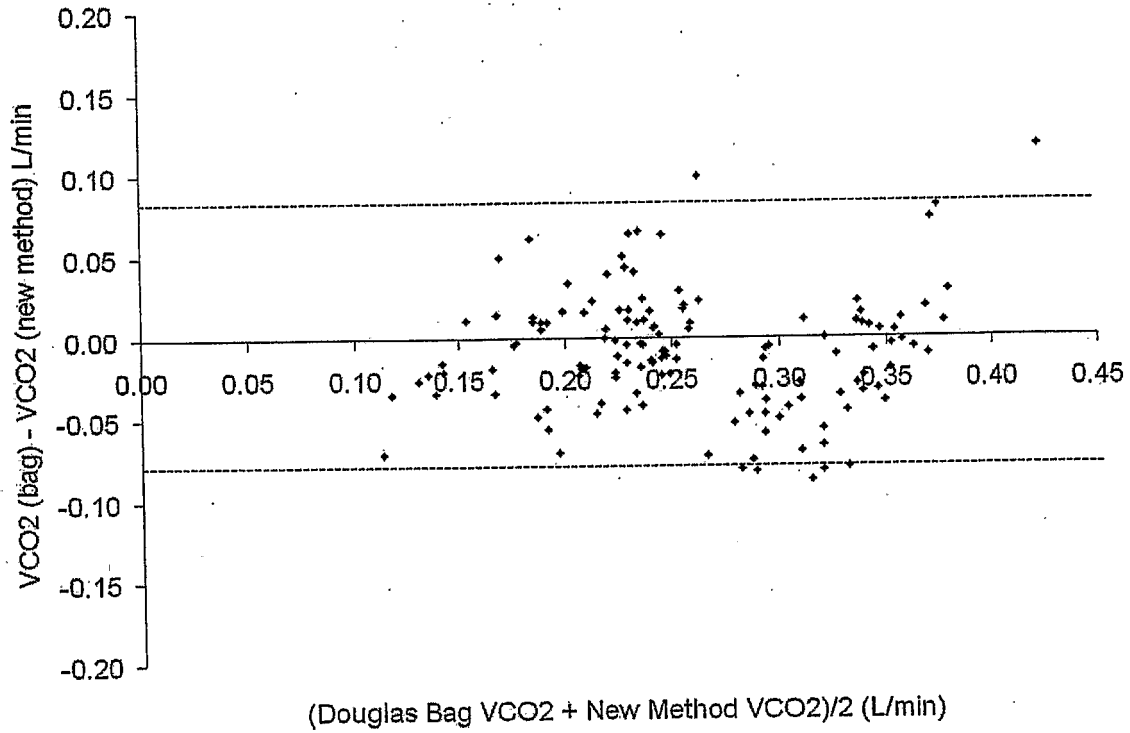

Figure 10

Figure showing progressive measurements of \dot{V}_{CO_2} using the standard bag collection, our new method, and a metabolic cart. Note the consistency of the new method compared to that of the others.

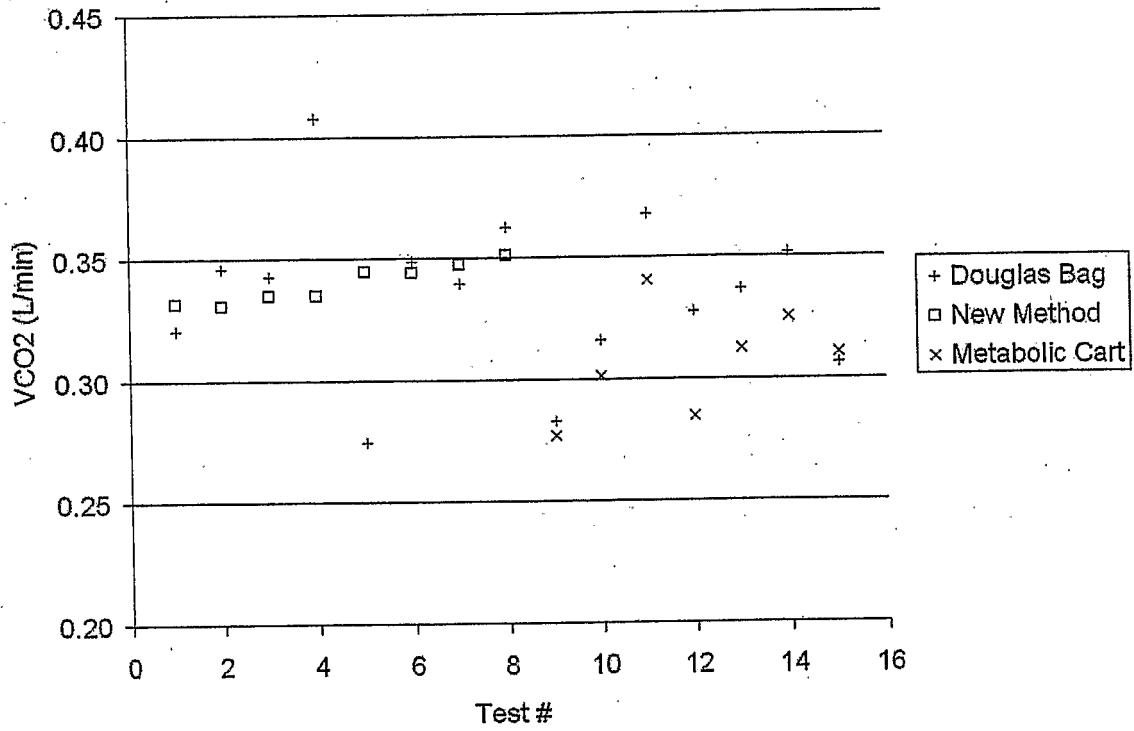

Figure 11

INTERNATIONAL SEARCH REPORT

Internat. Application No
PCT/CA 03/00399

A. CLASSIFICATION OF SUBJECT MATTER
IPC 7 A61M16/00 A61B5/00

According to International Patent Classification (IPC) or to both national classification and IPC

B. FIELDS SEARCHED
Minimum documentation searched (classification system followed by classification symbols)
IPC 7 A61M A61B F16K

Documentation searched other than minimum documentation to the extent that such documents are included in the fields searched

Electronic data base consulted during the international search (name of data base and, where practical, search terms used)
MEDLINE, EPO-Internal, PAJ

C. DOCUMENTS CONSIDERED TO BE RELEVANT

Category °	Citation of document, with indication, where appropriate, of the relevant passages	Relevant to claim No.
A	FR 2 784 587 A (SAIME SARL) 21 April 2000 (2000-04-21) abstract; figures page 6, line 3 -page 14, line 31 ---	17
A	WO 98 41266 A (FISHER JOSEPH A) 24 September 1998 (1998-09-24) abstract; figures page 9, line 3-27 page 13, line 6 -page 14, line 21 ---	17
A	FR 2 784 297 A (TAEMA) 14 April 2000 (2000-04-14) abstract; figures page 8, line 3 -page 11, line 35 ---	17
	-/--	

Further documents are listed in the continuation of box C. Patent family members are listed in annex.

° Special categories of cited documents:

A document defining the general state of the art which is not considered to be of particular relevance	*T* later document published after the international filing date or priority date and not in conflict with the application but cited to understand the principle or theory underlying the invention
E earlier document but published on or after the international filing date	*X* document of particular relevance; the claimed invention cannot be considered novel or cannot be considered to involve an inventive step when the document is taken alone
L document which may throw doubts on priority claim(s) or which is cited to establish the publication date of another citation or other special reason (as specified)	*Y* document of particular relevance; the claimed invention cannot be considered to involve an inventive step when the document is combined with one or more other such documents, such combination being obvious to a person skilled in the art.
O document referring to an oral disclosure, use, exhibition or other means	*Z* document member of the same patent family
P document published prior to the international filing date but later than the priority date claimed	

Date of the actual completion of the international search 11 July 2003	Date of mailing of the international search report 06/08/2003
---	--

Name and mailing address of the ISA European Patent Office, P.B. 5818 Patentlaan 2 NL - 2280 HV Rijswijk Tel. (+31-70) 340-2040, Tx. 31 651 epo nl, Fax: (+31-70) 340-3016	Authorized officer Lager, J
--	------------------------------------

INTERNATIONAL SEARCH REPORT

Internati Application No

PCT/CA 03/00399

C.(Continuation) DOCUMENTS CONSIDERED TO BE RELEVANT

Category °	Citation of document, with indication, where appropriate, of the relevant passages	Relevant to claim No.
A	FR 2 565 100 A (AIR LIQUIDE) 6 December 1985 (1985-12-06) abstract; figures ---	17
A	US 4 401 115 A (MONNIER JEAN-PIERRE) 30 August 1983 (1983-08-30) abstract; figures column 3, line 67 -column 4, line 35 column 6, line 15-38 ---	17
A	PATENT ABSTRACTS OF JAPAN vol. 2000, no. 15, 6 April 2001 (2001-04-06) & JP 2000 346214 A (WATANABEGUMI:KK), 15 December 2000 (2000-12-15) abstract; figures -----	17

FURTHER INFORMATION CONTINUED FROM PCT/ISA/ 210

Continuation of Box I.2

Claims Nos.: 1-16,18-19

Claims 1, 2, 11, 15, 16, 17 (3 method and 3 device claims) have been drafted as independent claims and have at least partly overlapping scope. Such a plurality of independent claims with overlapping scope makes it difficult or even impossible to clearly determine the subject-matter for which protection is sought, so that the claims as a whole fail to comply with the clarity and conciseness requirements of Article 6 PCT. Consequently, only the subject-matter being regarded as clear and concise, namely claim 17 (described at page 31 and shown in Figure 6/11), have been searched.

Moreover, the method claims appear to fall under Rule 39.1(iv) PCT. The requirements of unity, Rule 13 PCT, have not been examined at this stage.

The applicant's attention is drawn to the fact that claims, or parts of claims, relating to inventions in respect of which no international search report has been established need not be the subject of an international preliminary examination (Rule 66.1(e) PCT). The applicant is advised that the EPO policy when acting as an International Preliminary Examining Authority is normally not to carry out a preliminary examination on matter which has not been searched. This is the case irrespective of whether or not the claims are amended following receipt of the search report or during any Chapter II procedure.

INTERNATIONAL SEARCH REPORT

International application No.
PCT/CA 03/00399

Box I Observations where certain claims were found unsearchable (Continuation of item 1 of first sheet)

This International Search Report has not been established in respect of certain claims under Article 17(2)(a) for the following reasons:

1. Claims Nos.:
because they relate to subject matter not required to be searched by this Authority, namely:

2. Claims Nos.: 1-16, 18-19
because they relate to parts of the International Application that do not comply with the prescribed requirements to such an extent that no meaningful International Search can be carried out, specifically:
see FURTHER INFORMATION sheet PCT/ISA/210

3. Claims Nos.:
because they are dependent claims and are not drafted in accordance with the second and third sentences of Rule 6.4(a).

Box II Observations where unity of invention is lacking (Continuation of item 2 of first sheet)

This International Searching Authority found multiple inventions in this international application, as follows:

1. As all required additional search fees were timely paid by the applicant, this International Search Report covers all searchable claims.

2. As all searchable claims could be searched without effort justifying an additional fee, this Authority did not invite payment of any additional fee.

3. As only some of the required additional search fees were timely paid by the applicant, this International Search Report covers only those claims for which fees were paid, specifically claims Nos.:

4. No required additional search fees were timely paid by the applicant. Consequently, this International Search Report is restricted to the invention first mentioned in the claims; it is covered by claims Nos.:

Remark on Protest

- The additional search fees were accompanied by the applicant's protest.
- No protest accompanied the payment of additional search fees.

INTERNATIONAL SEARCH REPORT

Information on patent family members

International Application No
PCT/CA 03/00399

Patent document cited in search report		Publication date	Patent family member(s)	Publication date
FR 2784587	A	21-04-2000	FR 2784587 A1	21-04-2000
WO 9841266	A	24-09-1998	WO 9841266 A1	24-09-1998
			AU 1919197 A	12-10-1998
			EP 0973572 A1	26-01-2000
			JP 2001516239 T	25-09-2001
			US 2003047187 A1	13-03-2003
			US 6354292 B1	12-03-2002
FR 2784297	A	14-04-2000	FR 2784297 A1	14-04-2000
			AU 6095199 A	01-05-2000
			EP 1121169 A1	08-08-2001
			WO 0021596 A1	20-04-2000
			JP 2002527152 T	27-08-2002
FR 2565100	A	06-12-1985	FR 2565100 A1	06-12-1985
US 4401115	A	30-08-1983	FR 2483785 A1	11-12-1981
			AT 17656 T	15-02-1986
			DE 3173610 D1	13-03-1986
			EP 0042321 A1	23-12-1981
			EP 0127905 A2	12-12-1984
			ES 8203616 A1	16-07-1982
JP 2000346214	A	15-12-2000	NONE	

专利名称(译)	在呼吸期间连续测量肺中气体的FLUX的方法		
公开(公告)号	EP1487525A1	公开(公告)日	2004-12-22
申请号	EP2003707977	申请日	2003-03-21
[标]申请(专利权)人(译)	FISHER JOSEPH		
申请(专利权)人(译)	FISHER , JOSEPH		
当前申请(专利权)人(译)	FISHER , JOSEPH		
[标]发明人	FISHER J TORONTO GRAL HOSP DEP OF ANESTH PREISS D TORONTO GRAL HOSP DEP OF ANESTH AZAMI T TORONTO GRAL HOSP DEP OF ANESTH VESELY A TORONTO GRAL HOSP DEP OF ANESTH PRISMAN E TORONTO GRAL HOSP DEP OF ANESTH ADAMS T TORONTO GRAL HOSP DEP OF ANESTH		
发明人	FISHER, J.,TORONTO GRAL. HOSP.,DEP. OF ANESTH. PREISS, D.,TORONTO GRAL. HOSP.,DEP. OF ANESTH. AZAMI, T.,TORONTO GRAL. HOSP.,DEP. OF ANESTH. VESELY, A.,TORONTO GRAL. HOSP.,DEP. OF ANESTH. PRISMAN, E.,TORONTO GRAL. HOSP.,DEP. OF ANESTH. ADAMS, T.,TORONTO GRAL. HOSP.,DEP. OF ANESTH.		
IPC分类号	A61B5/026 A61B5/08 A61B5/083 A61B5/087 A61M16/00 A61M16/01 A61M16/20 A61M16/22 A61B5/00		
CPC分类号	A61B5/412 A61B5/083 A61B5/0833 A61B5/0836 A61B5/087 A61B5/4821 A61B2562/0219 A61M16/0045 A61M16/024 A61M16/0833 A61M16/202 A61M16/204 A61M16/205 A61M16/206 A61M16/208 A61M16/209 A61M16/22 A61M2230/432 A61M2230/435 A61M2230/437		
优先权	2379353 2002-03-28 CA		
外部链接	Espacenet		

摘要(译)

一种计算在用于通气或自主呼吸受试者的CBC回路中的任何气体 (x) 的通量的方法, 例如所述气体 (x) a) 麻醉剂, 例如但不限于: i) N₂O; ii) 七氟醚; iii) 异氟烷; iv) 氟烷; v) 地黄;或类似物; b) 氧; c) 二氧化碳; 利用以下关系; 气体通量 (x) = SGF (FSX-FEX) 其中SGF =由麻醉师设置的从气体流量计读取的以升/分钟表示的进入呼吸回路 (CBC回路) 的气体流量的来源; FSX =源气体中气体X的分数浓度 (由麻醉师设置); FEX =通过便携式气体分析仪等确定的最终呼出气体中的气体X的分数浓度。