

(19) World Intellectual Property Organization  
International Bureau



(43) International Publication Date  
22 October 2009 (22.10.2009)

PCT

(10) International Publication Number  
WO 2009/128914 A1

- (51) International Patent Classification:  
A61B 5/00 (2006.01) A61B 5/1455 (2006.01)
- (21) International Application Number:  
PCT/US2009/002345
- (22) International Filing Date:  
15 April 2009 (15.04.2009)
- (25) Filing Language: English
- (26) Publication Language: English
- (30) Priority Data:  
61/045,180 15 April 2008 (15.04.2008) US
- (71) Applicant (for all designated States except US): **NONIN MEDICAL, INC.** [US/US]; 13700 1st Avenue North, Plymouth, MN 55441 (US).
- (72) Inventors; and
- (75) Inventors/Applicants (for US only): **JOHNSON, Timothy, L.** [US/US]; 3240 Lanewood Lane N, Plymouth, MN 55447 (US). **ULRICH, Franz** [US/US]; 4453 Zenith Ave S, Minneapolis, MN 55410 (US). **ISAACSON, Philip, O.** [US/US]; 6633 Horseshoe Curve, Chanhassen, MN 55317 (US).
- (74) Agents: **STEFFEY, Charles, E.** et al.; Schwegman Lundberg & Woessner, P.A., P.O. Box 2938, Minneapolis, MN 55402 (US).

(81) Designated States (unless otherwise indicated, for every kind of national protection available): AE, AG, AL, AM, AO, AT, AU, AZ, BA, BB, BG, BH, BR, BW, BY, BZ, CA, CH, CN, CO, CR, CU, CZ, DE, DK, DM, DO, DZ, EC, EE, EG, ES, FI, GB, GD, GE, GH, GM, GT, HN, HR, HU, ID, IL, IN, IS, JP, KE, KG, KM, KN, KP, KR, KZ, LA, LC, LK, LR, LS, LT, LU, LY, MA, MD, ME, MG, MK, MN, MW, MX, MY, MZ, NA, NG, NI, NO, NZ, OM, PG, PH, PL, PT, RO, RS, RU, SC, SD, SE, SG, SK, SL, SM, ST, SV, SY, TJ, TM, TN, TR, TT, TZ, UA, UG, US, UZ, VC, VN, ZA, ZM, ZW.

(84) Designated States (unless otherwise indicated, for every kind of regional protection available): ARIPO (BW, GH, GM, KE, LS, MW, MZ, NA, SD, SL, SZ, TZ, UG, ZM, ZW), Eurasian (AM, AZ, BY, KG, KZ, MD, RU, TJ, TM), European (AT, BE, BG, CH, CY, CZ, DE, DK, EE, ES, FI, FR, GB, GR, HR, HU, IE, IS, IT, LT, LU, LV, MC, MK, MT, NL, NO, PL, PT, RO, SE, SI, SK, TR), OAPI (BF, BJ, CF, CG, CI, CM, GA, GN, GQ, GW, ML, MR, NE, SN, TD, TG).

Published:

- with international search report (Art. 21(3))
- before the expiration of the time limit for amending the claims and to be republished in the event of receipt of amendments (Rule 48.2(h))

(54) Title: NON-INVASIVE OPTICAL SENSOR

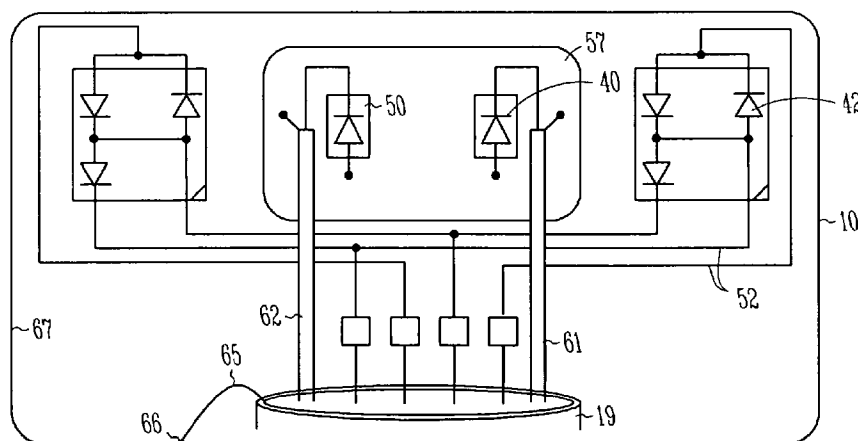

Fig. 4

(57) Abstract: An apparatus includes a sensor body, a circuit board, a cable, at least one light emitting device, and at least one photodetector. The circuit board is enclosed within the sensor body and includes at least one conductive trace and at least one aperture. The cable is coupled to the at least one conductive trace. The cable includes a shield conductor and a signal conductor. The at least one light emitting device is coupled to the circuit board and is configured to emit light into a tissue. The at least one photodetector includes a planar active area coupled to the circuit board and is configured to provide an output signal based on light detected by the active area. The planar active area is aligned with the aperture. The output signal is coupled to the cable.

WO 2009/128914 A1

## NON-INVASIVE OPTICAL SENSOR

5

### CLAIM OF PRIORITY

This patent application claims the benefit of priority to Johnson et al., U.S. Provisional Patent Application Serial Number 61/045,180, entitled "Non-Invasive Optical Sensor" filed on April 15, 2008, (Attorney Docket No. 2898.015PRV), which is incorporated herein by reference in its entirety.

10

### TECHNICAL FIELD

The present disclosure is directed to in vivo optical examination and monitoring of selected blood metabolites or constituents in human and/or other living subjects. More specifically, the present disclosure is directed to such examination and monitoring by transmitting selected wavelengths of light into a given area of the patient, receiving the resulting light as it leaves the patient, and analyzing the received light to determine the desired data based on light absorption.

20

### BRIEF SUMMARY OF THE INVENTION

The present subject matter provides improvements in optical sensor assemblies, particularly adapted for in vivo use as the patient interface in a patient-monitoring apparatus such as a cerebral or tissue oximeter. The present subject matter relates generally to in vivo optical examination and monitoring of selected blood metabolites or constituents in human and/or other living subjects by transmitting selected wavelengths of light into a given area of the patient, receiving the resulting light as it exits the patient, and analyzing the received light to determine the desired constituent data from which information such as blood oxygen saturation may be determined.

30

One application and field of use of the present subject matter is the non-invasive determination of tissue oxygenation. A further extension of the technology is related to non-invasive cerebral oximeter, by which blood oxygen saturation in the brain may be non-invasively determined through the use of an

optical sensor having light emitters and detectors that is applied to the forehead of the patient.

An example of the present subject matter provides an apparatus for in vivo monitoring of blood metabolites such as hemoglobin oxygen concentration  
5 in any of a plurality of different regions of a patient through application of a novel optical sensor assembly. The optical sensor assembly is coupled to a control and processing device, such as a monitor, that operates the sensor assembly to illuminate a particular region within the patient associated with the  
10 illumination, convey signals corresponding to the light energy so received, analyze the conveyed signals to determine preselected blood metabolite data, and display the data so obtained.

An apparatus in accordance with one embodiment of the present subject matter provides an optical probe having a flexible support or component-carrier  
15 and being adapted for comfortably conforming to the shape of the patient's cerebrum or other such anatomical area.

The foregoing has outlined rather broadly the features and technical advantages of the present subject matter in order that the detailed description that follows may be better understood. Additional features and advantages will be  
20 described hereinafter which form the subject of the claims of the invention. It should be appreciated by those skilled in the art that the conception and specific embodiment disclosed may be readily utilized as a basis for modifying or designing other structures for carrying out the same purposes. It should also be realized by those skilled in the art that such equivalent constructions do not  
25 depart from the spirit and scope of the present subject matter as set forth in the appended claims. The novel features which are believed to be characteristic of the present subject matter, both as to its organization and method of operation, together with further objects and advantages will be better understood from the following description when considered in connection with the accompanying  
30 figures. It is to be expressly understood, however, that each of the figures is provided for the purpose of illustration and description only and is not intended as a definition of the limits of the present subject matter.

## BRIEF DESCRIPTION OF THE DRAWINGS

For a more complete understanding, reference is now made to the following descriptions taken in conjunction with the accompanying drawing, in which:

5           FIG. 1A is a perspective illustration of application of a sensor assembly in accordance with the present subject matter.

          FIG. 1B is a block diagram of a sensor assembly in accordance with the present subject matter.

          FIG. 2 is an exploded perspective view of a sensor assembly.

10           FIG. 3 is a top plan view of the sensor assembly of FIG. 2.

          FIG. 4 is an electrical schematic of the sensor assembly of FIG. 2.

          FIG. 5 is a perspective view of a planar photodetector.

          FIG. 6 is a cross sectional view of the photodetector of FIG. 5 taken along lines 6 – 6.

15           FIG. 7 is a cross sectional view of the sensor assembly of FIG. 2 taken through a photodetector 40.

          FIG. 8 is an enlarged portion of the view of FIG. 7.

          FIG. 9 depicts a blanching structure of an embodiment of the present subject matter as applied to a tissue site.

20           FIG. 10 is a top plan view of another embodiment of the present subject matter.

## DETAILED DESCRIPTION OF THE INVENTION

A cerebral sensor assembly will be used by way of example in portions  
25 of the following description. However, it should be understood that other embodiments of the present subject matter could as well be applied to other types of physiological sensors, such as, for example, other types of tissue oximetry sensors for use on other locations on human and other living patients. FIG. 1A is a pictorial showing of a setting in which the sensor assembly, in  
30 accordance with the subject matter, can be used, as part of an operative system for monitoring or examining blood oxygen saturation of patients. For purposes of the present disclosure, FIG. 1A shows a system 8A having a sensor assembly 10 on a human patient 12 who is being monitored by an oximetry monitor 14. Sensor assembly 10 is applied to the forehead of the patient 12 to optically

access an internal tissue volume or regional field within the cerebrum, directly adjacent the point where sensor 10 is located, but inside of the scalp, skull, and adjacent dura, i.e., within the brain tissue itself. Sensor 10 is flexible and conforms to the forehead surface of patient 12.

5           The sensor assembly 10 is coupled to the oximetry monitor 14 through a cable 19 which includes individual conductors for energizing light emitters and operating the related light detectors contained in sensor assembly 10. The oximetry monitor 14, in this example, is a monitor on which visual displays may be perceived. A variety of different control and processing unit could also be  
10 implemented in a different system utilizing the sensor assembly of the present subject matter to provide oximetry or other physiological information. Monitor 14 can, in one example include memory for storage of data. In one example, monitor 14 does not include a visual display. The data stored in monitor 14 can be forwarded to another device or processor for subsequent storage or  
15 processing. The data can be communicated by a wired link or by a wireless link.

FIG. 1B illustrates system 8B having intermediary pod 110. Pod 110 is coupled to sensor assembly 10 by cable 19, as described elsewhere in this document. In one example, cable 19 carries a low level signal. Pod 110, in the example illustrated, includes processor 120, memory 115, and communication  
20 module 125, however, other examples can include more or less modules. Other modules also contemplated for pod 110 include an analog-to-digital converter (ADC), a digital-to-analog converter (DAC), a filter, an amplifier, and a power supply among others, some of which can be in the form of a discrete component or be implemented by means of processor 120. A power supply can include a  
25 battery. Processor 120, in the example illustrated includes programming (stored on memory 115) for executing an algorithm to evaluate or process data received from sensor assembly 10. Memory 115, in one example, includes storage for programming or instructions (for use by processor 120) and data corresponding to sensor assembly 10. In one example, pod 110 is configured as a component of  
30 monitor 14.

Communication module 125, in one example, includes a wired or wireless telemetry module for communicating with monitor 14 using communication link 130. For example, communication module 125 can include a Bluetooth wireless module in which case communication link 130 includes a

radio frequency communication channel. Communication module 125, and communication link 130 can be bidirectional or unidirectional. In one example, communication module 125 includes an interface to allow exchange of a high level signal using a wired communication channel.

5           Generally speaking, the sensor assembly 10 includes an elongated member with rounded corners, from which cable 19 extends outwardly. The particular embodiment of the sensor assembly 10 shown in FIG. 2 comprises a laminar "sandwich" construction and includes a cover layer 30 having, for example, a soft, flexible sheet of foam material or the like and a frontal layer 32.  
10          Frontal layer 32 may be a two-side adhesive layer or may be a combination of two-sided adhesive with a light-blocking layer. Cover layer 30 may include a black PVC or polyethylene foam layer. An electrical circuit board 34 is disposed between layers 30, 32. The two layers 30, 32 are secured to circuit board 34, for example, via adhesive.

15           Electro-optical devices including photodetectors 40 and light emitting devices 42 are connected to circuit board 34. The photodetectors 40 and light emitting devices 42 are disposed in registration with appropriate apertures 50 extending through the circuit board 34 and frontal layer 32 and through which such optical components may access the patient 12 (by emitting light which  
20          transmits through the scalp, skull and brain tissue of region, and then detecting resultant light after it leaves such region and passes back out of the patient through the skull and scalp, etc.).

            The illustrated embodiment of sensor assembly 10 includes a pair of light emitting devices 42 and a pair of photodetectors 40. The sensor assembly 10 and  
25          monitor 14 may include subject matter disclosed in U.S. patent application, Ser. No. 11/078,399, entitled *In Vivo Blood Spectrometry*, to P. Bernreuter, said application being incorporated by reference herein for all purposes.

            In the illustrated embodiment, the electrical circuit board 34 is approximately the same size as the outer dimensions of the cover layer 30 and  
30          frontal layer 32, which provide the outwardly visible shape of sensor assembly 10. In alternative embodiments, the board 34 may be sized differently than the cover or frontal layers 30, 32.

            Referring to FIG. 3, circuit board 34 can include a printed circuit board having a support substrate and printed conductor traces 52 secured to one side.

The photodetectors 40, as well as the light emitting devices 42, are electrically connected to the respective conductor traces 52. In one embodiment, the circuit board 34 may be of a flexible type, sometimes referred to as a flex circuit.

5 Separate copper shield elements 55 are positioned above light detecting devices 40. Insulators 56, such as an adhesive tape, electrically isolate shield elements 55 from the photodetectors 40. Circuit board 34 also defines a shield conductor 57 on the same plane as conductive traces 52. In the illustrated embodiment, shield conductor 57 extends generally across the circuit board 34. Apertures 50 extend through shield conductor 57. Foil shield elements 55, 10 which may include a copper tape, are electrically connected to shield conductor 57 at multiple locations 58. These electrical connections between shield elements 55 and shield conductor 57 may be via techniques including, but not limited to, soldering, conductive epoxies, etc.

FIG. 4 illustrates an electrical schematic of an embodiment of sensor 10. 15 Cable 19 includes a pair of coaxial lines 61, 62 and a series of control lines connected to traces 52 at locations 63A, 63B, 63C, and 63D shown in FIG. 3. The shields of coaxial lines 61, 62 connect to shield conductor 57. The center conductors of coaxial lines 61, 62 connect to cathode terminals T1 and are shielded by shield elements 55. The conductor bundle of cable 19 can be in the 20 form of a shielded cable, i.e., having a metallic braid or mesh sleeve 65 which peripherally surrounds the electrical conductors (which are mutually insulated from one another). Mesh sleeve 65 is connected to a ring trace 66 at location 67. In one example, location 67 includes a shield component. The shield component can include a metal housing, a conductive housing, or other structure to limit 25 undesirable effects of electromagnetic interference.

FIG. 5 is a perspective illustration of photodetector 40. In one embodiment, photodetector 40 is a planar solderable photodiode. Photodetectors 40 includes an anode terminal, T2, and a cathode terminal, T1. In one example, an active (sensing) area 51 is defined on the same side as anode terminal, T2.

30 FIG. 6 is a cross sectional view of the photodetector 40 of FIG. 5 taken along lines 6-6. FIG. 7 depicts a cross sectional view taken through sensor assembly 10. FIG. 8 illustrates detailed portion 85 (denoted by the dashed line circle) of FIG. 7. As shown, photodetector 40 is directly connected to shield 57 at terminal T2. The electrical connection can be via solder, conductive epoxies,

or other techniques. As shown in FIGS. 2, 6 and 7, the photodetector 40 is larger in size than apertures 50 of circuit board 34. In one embodiment, apertures 50 are entirely covered by active areas 51 of the photodetectors 40. In one embodiment, photodetectors 40 are directly soldered to the shield conductor 57 at terminals T2 and the overlying shield elements 55 are also soldered to shield conductor 57 as shown in FIG. 3. In other embodiments, photodetectors 40 may be operatively coupled to the shield conductor 57 via techniques, such as conductive epoxies.

FIG. 9 depicts another cross sectional view of sensor assembly 10 wherein an optically transparent bump feature 80 extends from a lower surface of sensor 10 and is positioned between a light emitting device and/or light detector and tissue site 81. When sensor assembly 10 is applied at tissue site 81, bump feature 80 functions to blanch tissue immediately under the bump feature by applying an increased pressure to the tissue. The blood-blanching tissue reduces nearby light absorbance which in turn increases signal quality. Bump feature 80 further functions to increase the effective area for light to/from light emitting devices 42 and photodetectors 40 to enter and/or leave the tissue, further increasing signal quality. Bump feature 80 may also provide more consistent and reliable contact with the tissue surface. Bump feature 80 is formed by clear molded plastic or clear epoxy, encapsulant, or adhesive. Bump feature 80, in one example, protrudes sufficiently from a surface of sensor assembly 10 in order to blanch the tissue in the region of interest.

In one embodiment, light emitting devices 42 are light emitting diodes (LEDs). There may be several different individual such LEDs, each for producing a specifically selected different light wavelength. While it is also possible to implement the present subject matter in other configurations, e.g., with remotely located light-producing elements and fiberoptic conductors and emitters, the configuration illustrated provides certain advantages, particularly in conjunction with present-day LEDs, which can provide high light intensity from a very small component with relatively low excitation.

The relative separation (distance between) the light emitting devices 42 and the photodetectors 40 relates to the particular purpose, function and application of the system which the sensor assembly 10 is to be used. In one example, the relative separation (distance) effectively determine the location and

size of the particular internal region which is to be selectably examined by the interrogating light wavelengths. In one embodiment, the distances between the emitters and detectors are substantially equivalent. Additional details regarding spacing of the light emitting devices 42 relative to photodetectors 40 may be  
5 found in the above-referenced application, U.S. Ser. No. 11/078,399. However, in the broader aspects of the underlying subject matter, various such distances may be determined and specified without otherwise changing the overall nature of the apparatus and methodology.

FIG. 10 illustrates another embodiment of the sensor assembly 10.  
10 Relief features 70 are provided around the perimeter of the sensor body to permit greater conformity to a smaller or "spherically" shaped surface, such as a forehead. The relief features 70 can be located away from the photodetectors 40 for improved immunity to ambient light. Relief features 70 may include slits, slots, cut-outs, etc.

15 Further general aspects of the sensor assembly 10 include the following. The frontal layer 32 may be of black, light-absorbing material, in order to more effectively isolate ambient light from the photodetectors, as well as to minimize the possibility of surface leakage between light emitting devices 42 and photodetectors 40. This helps ensure that photons received by the detectors have  
20 actually transmitted the tissue of the patient, and thus carry desired information. The cover layer 30 of the sensor assembly 10 can be opaque to ambient light, i.e., is of dense black material such as a sheet of polymeric foam material.

In the actual usage of the sensor assembly 10, it is applied to anatomical surfaces which are not likely to be perfectly flat, and which on the contrary are at  
25 least moderately curved; in fact, such curvature is likely to be compound in nature (i.e., not simply cylindrical), and the nature and extent of such curvature will vary from patient to patient, with a considerable degree of variation between some individuals.

An optical sensor assembly 10 of the present subject matter has a  
30 photodetector 40 which is directly connected to a shield conductor 57. In one example, the photodetector 40 is soldered directly to a shield conductor 57 proximate to an aperture 50 of the shield conductor. The photodetector's active area 51 can be larger in size than the shield conductor aperture 50. The shield conductor 57 may be defined as a conductive layer of a flexible circuit board 34.

In another embodiment, the shield conductor 57 may be one side of an enclosed structure, such as a hollow conductive box. By mounting the active side 51 of photodetector 40 directly to the shield conductor 57, deleterious effects of capacitive coupling to the patient body or nearby objects can be reduced or  
5 eliminated.

In one embodiment, the sampling rate of system 8A or system 8B occurs at a subharmonic frequency of 50/60 hertz, such as 18.75 hertz. Sampling at such frequency provides improved digital filter performance and interference rejection.

10 In one embodiment, the sensor assembly 10 includes a memory in which information related to the sensor's use, manufacture or condition may be stored. For example, sensor assembly 10 may store sensor-specific spectral and/or calibration information accessible to a remote monitor or other control. Sensor assembly 10, pod 110, or both sensor assembly 10 and pod 110 can incorporate  
15 subject matter relating to on-sensor data storage disclosed in U.S. Ser. No. 11/039,760, entitled *Sensor System with Memory and Method of Using Same*, incorporated by reference herein for all purposes.

In another embodiment, the sensor body may be provided in a more monolithic form, and even as a one-piece integrally molded part, rather than in  
20 the illustrated layered constructions. Such a one-piece structure may simplify manufacturing, and may achieve other economies as well. In one example, the electro-optical components are sealed in place and not exposed to the environment, and may be embedded integrally (with their connective wiring, shielding, etc.) inside either an integrally molded or a permanently joined and  
25 completely sealed laminate body structure.

### **Additional Notes**

One embodiment of a sensor assembly includes a light emitting device which emits light into a tissue field, a photodiode having a generally planar  
30 active area and receiving some of the emitted light, and a flexible conductive shield element conforming to a surface of said tissue field, with the photodiode covering an aperture of the shield element, and with an area of said aperture being smaller than the photodiode active area.

One embodiment of the sensor assembly 10 has a conductive shield element formed as a flex circuit. The sensor assembly 10 has a photodiode terminal adjacent to the active area, with the terminal being electrically connected to a conductor of the shield element. The photodiode may be a solderable photodiode. The conductive shield element is a flex circuit with a terminal of the photodiode directly soldered to the conductive shield element proximate to the aperture. The sensor assembly of the first embodiment includes a second terminal on a photodiode side opposite the active area. The second terminal in this embodiment is a cathode terminal of the photodiode. The sensor assembly 10 has a flexible conductive foil-like shield secured over the photodiode and being conductively connected to the shield element. The sensor assembly also includes an insulator for preventing electrical coupling between a cathode terminal of the photodiode and the conductive cover. The sensor assembly 10 has an adhesive layer for securing the sensor assembly to the tissue field.

Although the present subject matter and some advantages have been described in detail, it should be understood that various changes, substitutions and alterations can be made herein without departing from the spirit and scope of the invention. Moreover, the scope of the present application is not intended to be limited to the particular embodiments of the process, machine, manufacture, composition of matter, means, methods and steps described in the specification. As one of ordinary skill in the art will readily appreciate from the disclosure of the present subject matter, processes, machines, manufacture, compositions of matter, means, methods, or steps, presently existing or later to be developed that perform substantially the same function or achieve substantially the same result as the corresponding embodiments described herein may be utilized according to the present subject matter.

## WHAT IS CLAIMED IS:

1. A system comprising:  
a monitor; and  
a sensor assembly coupled to the monitor by a cable, the sensor assembly including a circuit board electrically coupled to at least one light emitting device and coupled to at least one photodetector, the at least one light emitting device configured to emit light into a tissue and the at least one photodetector configured to provide an output signal based on light detected by a planar active area of the at least one photodetector, the planar active area aligned with an aperture of the circuit board; and  
wherein the monitor is configured to receive data corresponding to the output signal and corresponding to at least one of oximetry information for the tissue and physiological information for the tissue.
2. The system of claim 1 wherein the sensor assembly includes a perimeter and a plurality of relief features distributed about the perimeter.
3. The system of claim 1 wherein the sensor assembly is configured to couple with a spherically shaped surface.
4. The system of claim 1 wherein the sensor assembly includes a bump feature on a surface, the bump feature configured to blanch a region of the tissue.
5. The system of claim 1 wherein the at least one light emitting device includes a fiber optic element.
6. The system of claim 1 wherein the at least one light emitting device includes a light emitting diode (LED).
7. The system of claim 1 wherein the circuit board includes a flexible circuit board.
8. The system of claim 1 wherein the at least one photodetector is soldered to the circuit board.

9. The system of claim 1 wherein the at least one photodetector is affixed to the circuit board by an adhesive.
10. The system of claim 1 wherein the monitor includes a visual display.
11. The system of claim 1 further including a pod coupled to the cable, the pod having a memory configured to store data corresponding to the sensor assembly.
12. The system of claim 11 wherein the pod includes a processor and wherein the memory is configured to store executable instructions for the processor.
13. The system of claim 11 wherein the pod includes a communication module configured to communicate with the monitor.
14. The system of claim 13 wherein the communication module is configured for wireless communication.
15. An apparatus comprising:
  - a sensor body;
  - a circuit board enclosed within the sensor body, the circuit board having at least one conductive trace and at least one aperture;
  - a cable coupled to the at least one conductive trace, the cable having a shield conductor and a signal conductor;
  - at least one light emitting device coupled to the circuit board, the at least one light emitting device configured to emit light into a tissue;
  - at least one photodetector having a planar active area coupled to the circuit board, the at least one photodetector configured to provide an output signal based on light detected by the active area, the planar active area aligned with the aperture; and
  - wherein the output signal is coupled to the cable.

16. The apparatus of claim 15 wherein the sensor body includes a perimeter and a plurality of relief features distributed about the perimeter.
17. The apparatus of claim 15 wherein a surface of the sensor body includes foam.
18. The apparatus of claim 17 wherein the foam is black.
19. The apparatus of claim 15 wherein a surface of the sensor body includes an adhesive.
20. The apparatus of claim 15 wherein an end of the cable is configured to couple with a monitor.
21. The apparatus of claim 15 further including a conductive adhesive connection to the at least one conductive trace.
22. The apparatus of claim 15 further including a solder connection to the at least one conductive trace.
23. The apparatus of claim 15 wherein the circuit board includes a flexible circuit board.
24. The apparatus of claim 15 wherein the sensor body is configured to couple with a spherically shaped surface.
25. The apparatus of claim 15 wherein the sensor body includes a bump feature on a surface, the bump feature configured to blanch a region of the tissue.
26. The apparatus of claim 15 wherein the at least one light emitting device includes a fiber optic element.
27. The apparatus of claim 15 wherein the at least one light emitting device includes a light emitting diode (LED).

28. The apparatus of claim 15 wherein the at least one photodetector is soldered to the circuit board.
29. The apparatus of claim 15 wherein the at least one photodetector is affixed to the circuit board by an adhesive.
30. A method comprising:  
coupling at least one light emitting device to a circuit board;  
coupling a photodiode to the circuit board, the photodiode having a planer surface aligned with an aperture of the circuit board;  
coupling a cable to at least one conductive trace of the circuit board; and  
assembling the circuit board to a sensor body, the sensor body having an adhesive surface.
31. The method of claim 30 further including forming at least one relief feature at a perimeter of the sensor body.
32. The method of claim 30 further including forming a bump feature on a surface of the sensor body, the bump feature configured to blanch a region of tissue when the sensor body is affixed to the tissue.
33. The method of claim 30 wherein coupling the at least one light emitting diode includes forming at least one of a conductive adhesive joint and a soldered joint.
34. The method of claim 30 wherein coupling the at least one photodetector includes forming at least one of a conductive adhesive joint and a soldered joint.

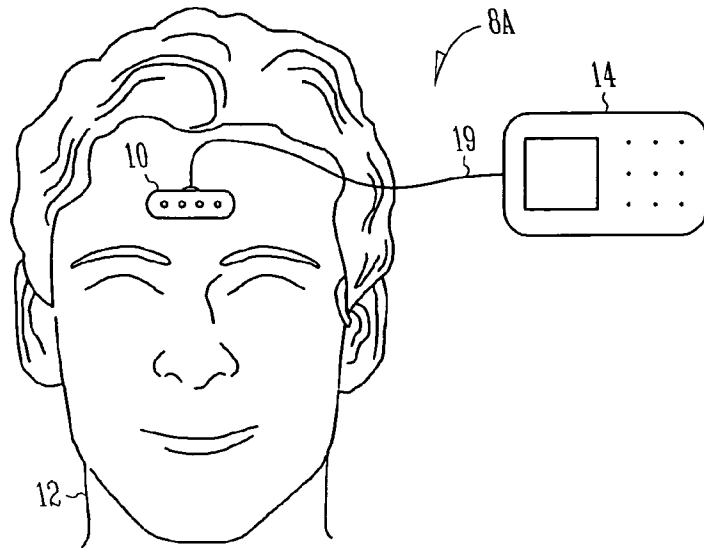

Fig. 1A

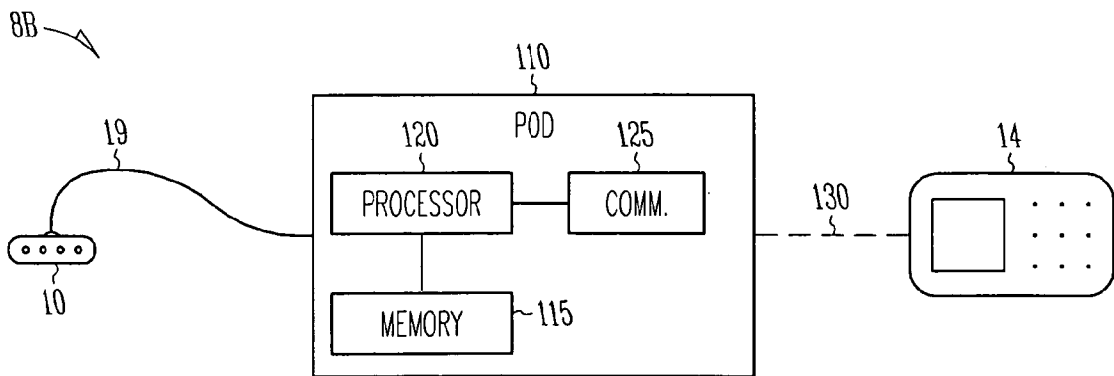
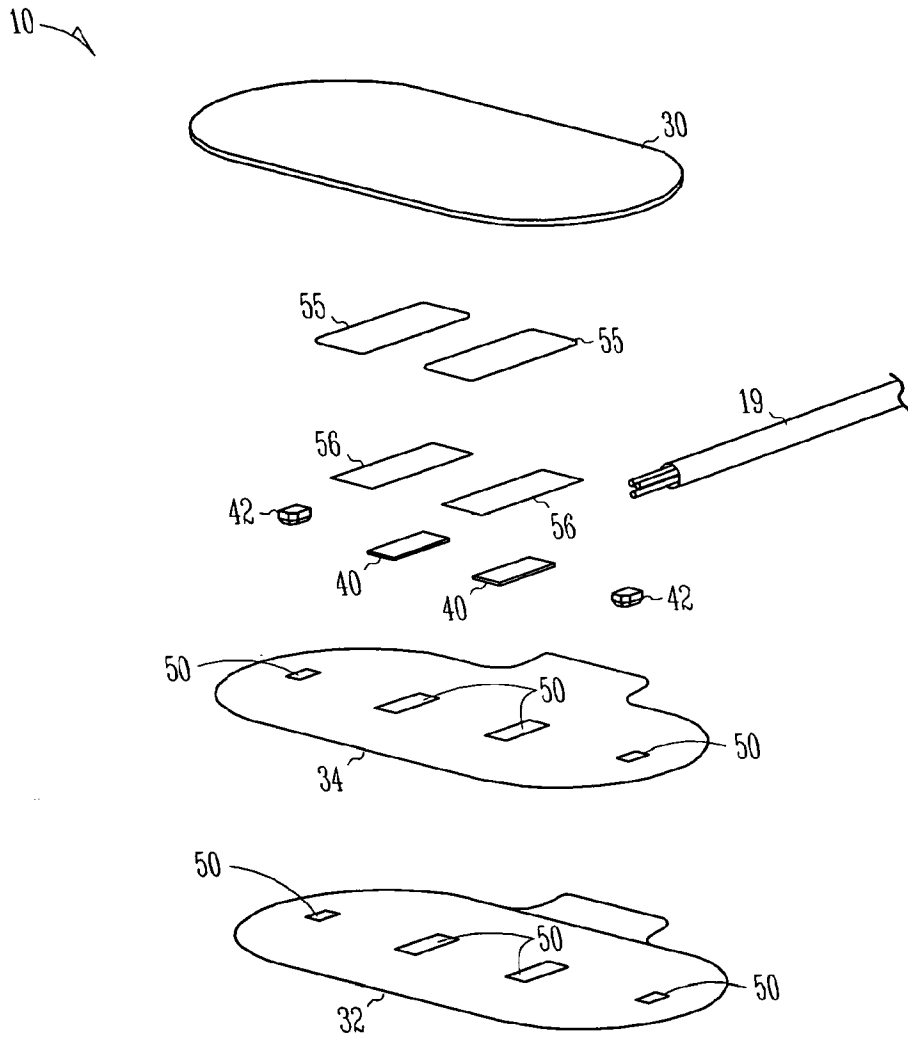

Fig. 1B



*Fig. 2*

3/7

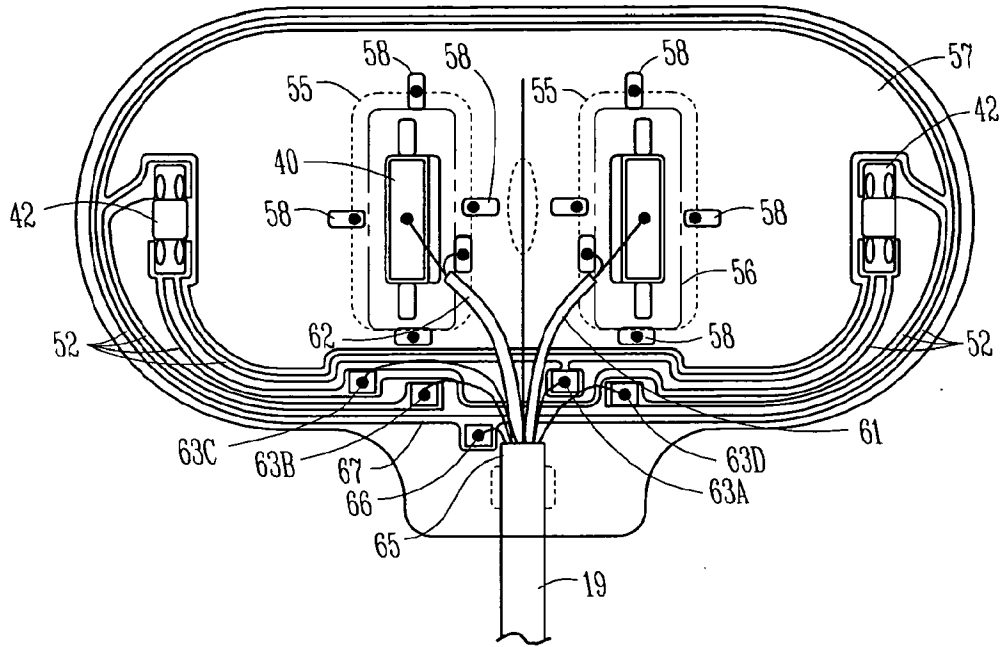

Fig. 3

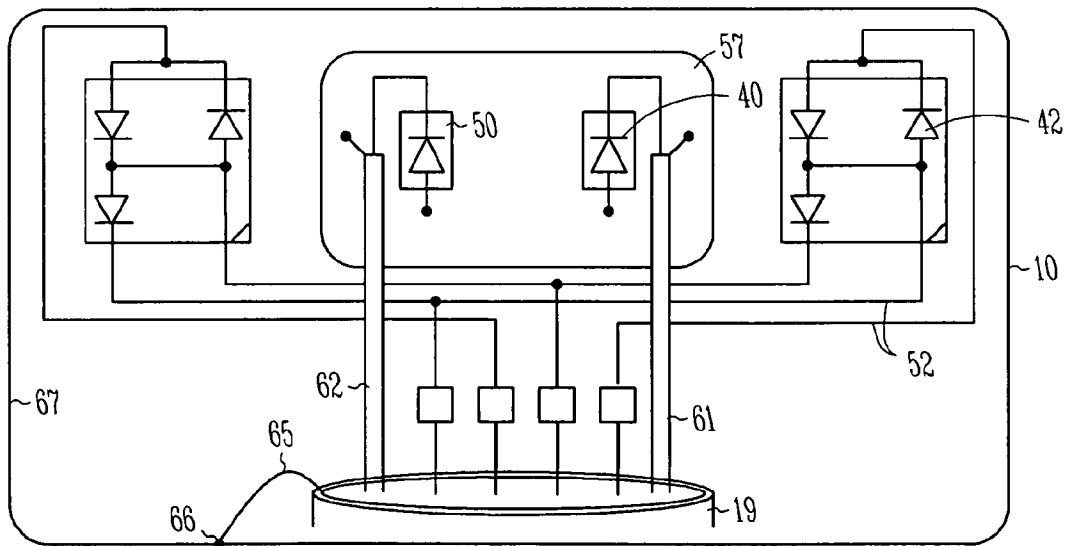

Fig. 4

4/7

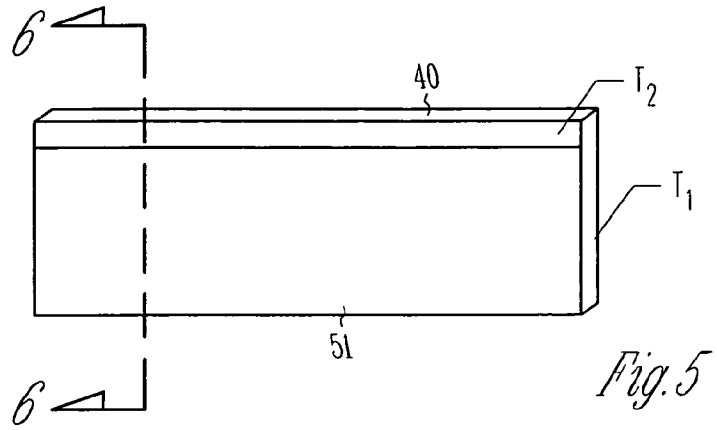

Fig. 5

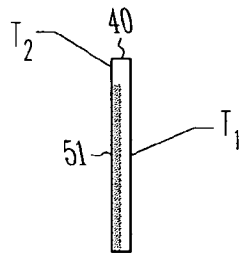

Fig. 6

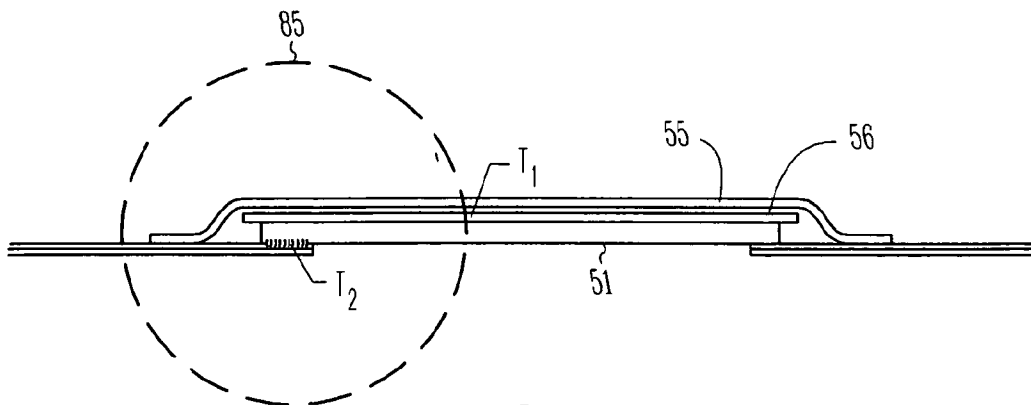
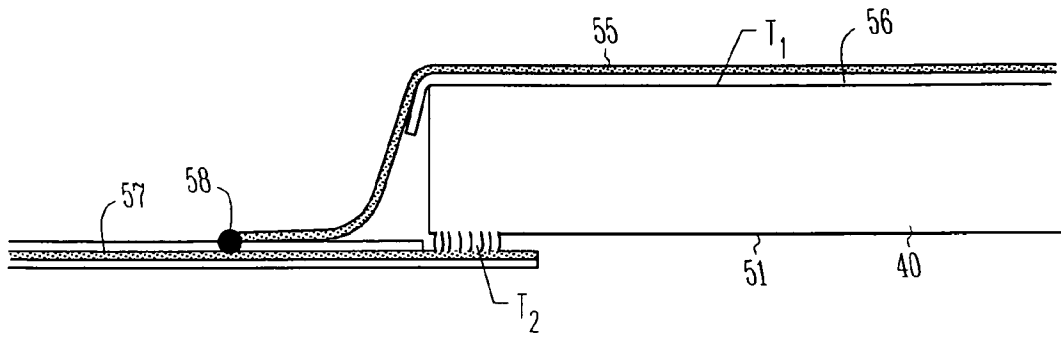
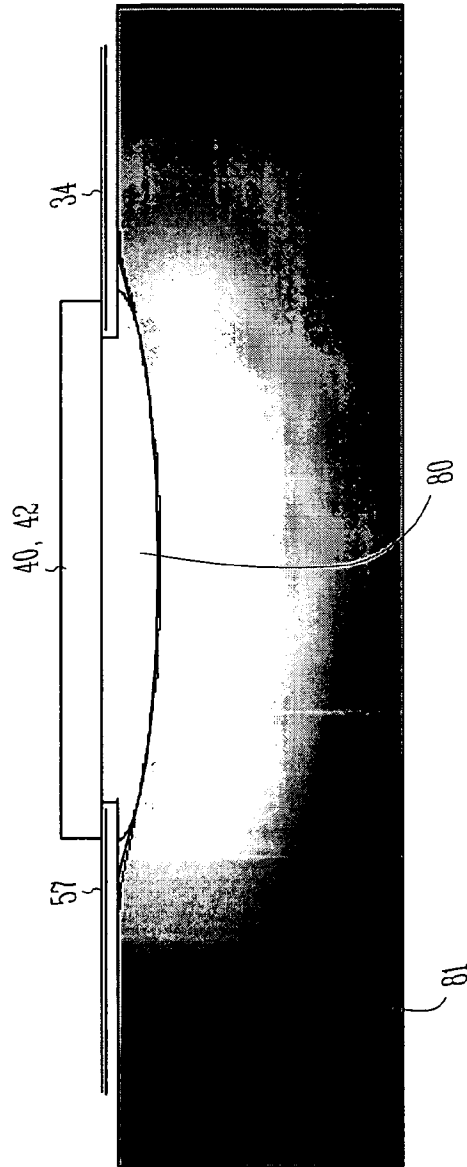

Fig. 7

5/7



*Fig. 8*



*Fig. 9*

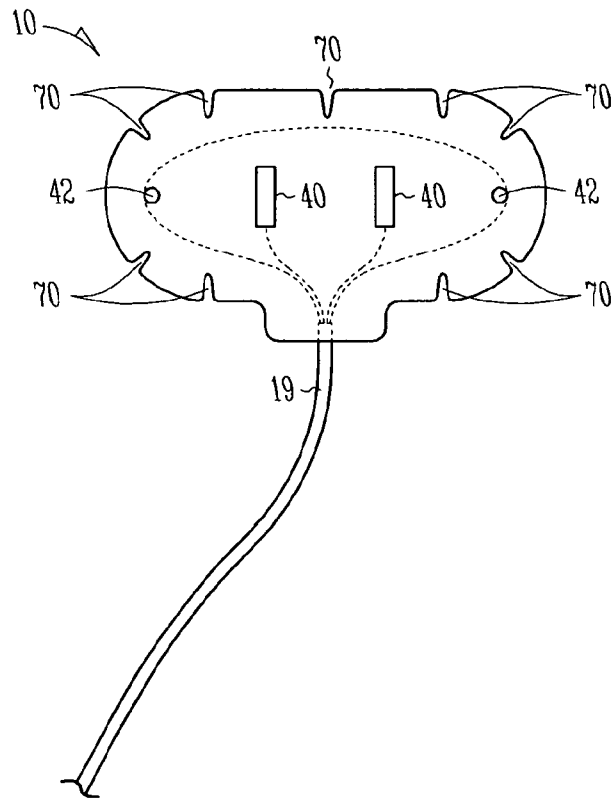

*Fig. 10*

**INTERNATIONAL SEARCH REPORT**

International application No  
PCT/US2009/002345

<b>A. CLASSIFICATION OF SUBJECT MATTER</b> INV. A61B5/00                      A61B5/1455				
According to International Patent Classification (IPC) or to both national classification and IPC				
<b>B. FIELDS SEARCHED</b>				
Minimum documentation searched (classification system followed by classification symbols) A61B				
Documentation searched other than minimum documentation to the extent that such documents are included in the fields searched				
Electronic data base consulted during the international search (name of data base and, where practical, search terms used) EPO-Internal, WPI Data				
<b>C. DOCUMENTS CONSIDERED TO BE RELEVANT</b>				
Category*	Citation of document, with indication, where appropriate, of the relevant passages	Relevant to claim No.		
X Y	WO 94/12096 A (SOMANETICS CORP [US]) 9 June 1994 (1994-06-09) abstract  page 2, line 25 - line 28 page 5, line 16 - page 9, line 31 claims 1-22 figures 1-7,11	1-10, 15-29 11-14, 31-34		
X Y	US 5 891 026 A (WANG HUISUN [US] ET AL) 6 April 1999 (1999-04-06) abstract column 2, line 53 - column 5, line 19 figures 1-6 claims 13-15	1,15,30  31-34		
	----- -/-- -----			
<input checked="" type="checkbox"/> Further documents are listed in the continuation of Box C. <input checked="" type="checkbox"/> See patent family annex.				
* Special categories of cited documents :				
<table style="width:100%; border:none;"> <tr> <td style="width:50%; vertical-align:top;">                     *A* document defining the general state of the art which is not considered to be of particular relevance                      *E* earlier document but published on or after the international filing date                      *L* document which may throw doubts on priority claim(s) or which is cited to establish the publication date of another citation or other special reason (as specified)                      *O* document referring to an oral disclosure, use, exhibition or other means                      *P* document published prior to the international filing date but later than the priority date claimed                 </td> <td style="width:50%; vertical-align:top;">                     *T* later document published after the international filing date or priority date and not in conflict with the application but cited to understand the principle or theory underlying the invention                      *X* document of particular relevance; the claimed invention cannot be considered novel or cannot be considered to involve an inventive step when the document is taken alone                      *Y* document of particular relevance; the claimed invention cannot be considered to involve an inventive step when the document is combined with one or more other such documents, such combination being obvious to a person skilled in the art.                      *&amp;* document member of the same patent family                 </td> </tr> </table>			*A* document defining the general state of the art which is not considered to be of particular relevance *E* earlier document but published on or after the international filing date *L* document which may throw doubts on priority claim(s) or which is cited to establish the publication date of another citation or other special reason (as specified) *O* document referring to an oral disclosure, use, exhibition or other means *P* document published prior to the international filing date but later than the priority date claimed	*T* later document published after the international filing date or priority date and not in conflict with the application but cited to understand the principle or theory underlying the invention *X* document of particular relevance; the claimed invention cannot be considered novel or cannot be considered to involve an inventive step when the document is taken alone *Y* document of particular relevance; the claimed invention cannot be considered to involve an inventive step when the document is combined with one or more other such documents, such combination being obvious to a person skilled in the art. *&* document member of the same patent family
*A* document defining the general state of the art which is not considered to be of particular relevance *E* earlier document but published on or after the international filing date *L* document which may throw doubts on priority claim(s) or which is cited to establish the publication date of another citation or other special reason (as specified) *O* document referring to an oral disclosure, use, exhibition or other means *P* document published prior to the international filing date but later than the priority date claimed	*T* later document published after the international filing date or priority date and not in conflict with the application but cited to understand the principle or theory underlying the invention *X* document of particular relevance; the claimed invention cannot be considered novel or cannot be considered to involve an inventive step when the document is taken alone *Y* document of particular relevance; the claimed invention cannot be considered to involve an inventive step when the document is combined with one or more other such documents, such combination being obvious to a person skilled in the art. *&* document member of the same patent family			
Date of the actual completion of the international search  <p align="center">6 August 2009</p>	Date of mailing of the international search report  <p align="center">19/08/2009</p>			
Name and mailing address of the ISA/ European Patent Office, P.B. 5818 Patentlaan 2 NL - 2280 HV Rijswijk Tel. (+31-70) 340-2040, Fax: (+31-70) 340-3016	Authorized officer  <p align="center">Tommaseo, Giovanni</p>			

## INTERNATIONAL SEARCH REPORT

International application No  
PCT/US2009/002345

C(Continuation). DOCUMENTS CONSIDERED TO BE RELEVANT

Category*	Citation of document, with indication, where appropriate, of the relevant passages	Relevant to claim No.
X	<p>HAAHR R G ET AL: "A Novel Photodiode for Reflectance Pulse Oximetry in low-power applications" ENGINEERING IN MEDICINE AND BIOLOGY SOCIETY, 2007. EMBS 2007. 29TH ANNUAL INTERNATIONAL CONFERENCE OF THE IEEE, IEEE, PISCATAWAY, NJ, USA, 22 August 2007 (2007-08-22), pages 2350-2353, XP031336677 ISBN: 978-1-4244-0787-3 abstract figures 1,3 page 2350 - page 2351</p>	1,15
Y	<p>US 2007/142715 A1 (BANET MATTHEW J [US] ET AL) 21 June 2007 (2007-06-21) abstract paragraph [0028] - paragraph [0030] figures 1,2,5 claims 1,9,10,13</p>	11-14
A	<p>US 2003/225323 A1 (KIANI MASSI E [US] ET AL) 4 December 2003 (2003-12-04) abstract figures 1,2,5 claims 1-10 paragraph [0015] - paragraph [0026]</p>	1,15
A	<p>US 2007/100219 A1 (SWEITZER ROBERT [US] ET AL) 3 May 2007 (2007-05-03) abstract figure 12 claims 1-17</p>	1,15

# INTERNATIONAL SEARCH REPORT

Information on patent family members

International application No

PCT/US2009/002345

Patent document cited in search report	A	Publication date	Patent family member(s)	Publication date
WO 9412096	A	09-06-1994	EP 0690692 A1 US 5584296 A	10-01-1996 17-12-1996
<hr style="border-top: 1px dashed black;"/>				
US 5891026	A	06-04-1999	US 6149481 A US 6073038 A	21-11-2000 06-06-2000
<hr style="border-top: 1px dashed black;"/>				
US 2007142715	A1	21-06-2007	NONE	
<hr style="border-top: 1px dashed black;"/>				
US 2003225323	A1	04-12-2003	US 2005277819 A1	15-12-2005
<hr style="border-top: 1px dashed black;"/>				
US 2007100219	A1	03-05-2007	AU 2006306629 A1 CA 2626313 A1 CN 101330865 A EP 1948009 A2 JP 2009513243 T KR 20080065985 A US 2009131774 A1 WO 2007050268 A2	03-05-2007 03-05-2007 24-12-2008 30-07-2008 02-04-2009 15-07-2008 21-05-2009 03-05-2007
<hr style="border-top: 1px dashed black;"/>				

专利名称(译)	无创光学传感器		
公开(公告)号	<a href="#">EP2306892A1</a>	公开(公告)日	2011-04-13
申请号	EP2009733542	申请日	2009-04-15
[标]申请(专利权)人(译)	NONIN医疗		
申请(专利权)人(译)	NONIN MEDICAL , INC.		
当前申请(专利权)人(译)	NONIN MEDICAL , INC.		
[标]发明人	JOHNSON TIMOTHY L ULRICH FRANZ ISAACSON PHILIP O		
发明人	JOHNSON, TIMOTHY, L. ULRICH, FRANZ ISAACSON, PHILIP, O.		
IPC分类号	A61B5/00 A61B5/1455		
CPC分类号	A61B5/14553 A61B5/14552 A61B5/6825 A61B5/6833 A61B5/6843		
优先权	61/045180 2008-04-15 US		
外部链接	<a href="#">Espacenet</a>		

#### 摘要(译)

一种装置包括传感器主体，电路板，电缆，至少一个发光器件和至少一个光电探测器。电路板封闭在传感器主体内，并包括至少一个导电迹线和至少一个孔。电缆耦合到至少一个导电迹线。电缆包括屏蔽导体和信号导体。至少一个发光器件耦合到电路板并且被配置为将光发射到组织中。所述至少一个光电检测器包括耦合到电路板的平面有源区域，并且被配置为基于由有源区域检测的光提供输出信号。平面有源区域与孔对齐。输出信号耦合到电缆。