



(12) **EUROPEAN PATENT APPLICATION**

(43) Date of publication:
31.07.2019 Bulletin 2019/31

(51) Int Cl.:
A61B 5/0408 (2006.01) A61B 5/00 (2006.01)

(21) Application number: **19152859.5**

(22) Date of filing: **21.01.2019**

(84) Designated Contracting States:
AL AT BE BG CH CY CZ DE DK EE ES FI FR GB GR HR HU IE IS IT LI LT LU LV MC MK MT NL NO PL PT RO RS SE SI SK SM TR
 Designated Extension States:
BA ME
 Designated Validation States:
KH MA MD TN

(72) Inventors:
 • **SUAREZ, Carlos A**
Skaneateles Falls, NY 13153-0220 (US)
 • **MARTIN, Scott A**
Skaneateles Falls, NY 13153-0220 (US)
 • **WAWRO, Thaddeus J**
Skaneateles Falls, NY 13153-0220 (US)
 • **FITCH, Timothy R**
Skaneateles Falls, NY 13153-0220 (US)

(30) Priority: **24.01.2018 US 201862621232 P**

(71) Applicant: **Welch Allyn, INC.**
Skaneateles Falls, NY 13153-0220 (US)

(74) Representative: **Findlay, Alice Rosemary**
Reddie & Grose LLP
The White Chapel Building
10 Whitechapel High Street
London E1 8QS (GB)

(54) **PHYSIOLOGICAL PARAMETER MONITOR WITH A CLEAT AND AN EQUIPMENT MODULE REMOVABLY ATTACHABLE TO THE CLEAT**

(57) A physiological monitor includes a cleat adapted to be securable to a subject such as a patient. The cleat includes an A electrode which includes an A electrode connector portion. The cleat also includes a B electrode which includes a B electrode connector portion. An equipment module is removably attached or removably attachable to the cleat in a transverse direction. The equipment

module has an A module connector portion and a B module connector portion arranged such that the A and B module connector portions connect with the A and B electrode connector portions respectively when the equipment module is connected to the cleat thereby placing the cleat and equipment module in signal communication with each other.

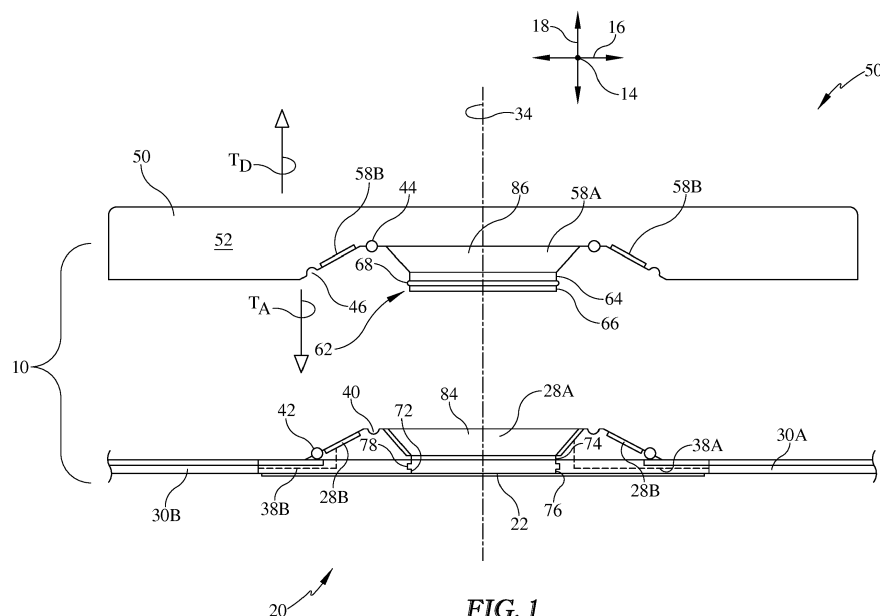

FIG. 1

Description

[0001] The subject matter described herein relates to medical vital signs monitors and particularly to a modular monitor having a module which is wearable by a subject (e.g. a medical patient) and a detachable module which is detachable from the wearable module. When the patient participates in activities which might be harmful to components of the detachable module, the detachable module can be detached from the wearable module while the wearable module remains in place on the patient. The detachable module can be subsequently reattached to the wearable module.

[0002] Wearable monitors for monitoring medical vital signs and other physiological parameters are advantageous because they can provide continuous monitoring of the vital signs of a subject, such as a hospital patient. Wearable monitors include an adhesive layer for securing the monitor to the patient. A caregiver presses the adhesive layer of the monitor against the patient's skin to secure the monitor to the patient's body.

[0003] One drawback of wearable monitors is the need to remove the monitor from the patient when the patient participates in activities that could cause damage to components of the monitor. Such activities include bathing, showering, and radiological procedures. At the conclusion of the activity it is desirable to resecure the wearable monitor to the patient. However the previous act of removing the monitor may have compromised the strength of the adhesive so that the monitor will no longer adhere reliably to the patient. Even if the monitor can be successfully reapplied to the patient, it is difficult to position the monitor exactly as it had been before removal. As a result the quality and/or consistency of the monitored signals may suffer. The monitor described herein overcomes at least these shortcomings of conventional vital signs monitors.

[0004] The invention will now be further described by way of example with reference to the accompanying drawings, in which:

FIG. 1 is a schematic cross sectional elevation view showing a cleat component and an equipment module component of the physiological monitor with the equipment module separated from the cleat and also showing A and B cleat electrodes, A and B connector portions of the electrodes, and A and B connector portions of the equipment module.

FIG. 2 is a view similar to FIG. 1 showing the equipment module attached to the cleat.

FIG. 3A is an elevation view showing the cleat of FIG. 1 with only the A electrode illustrated to assist the reader in identifying the features of the A electrode.

FIG. 3B is an elevation view showing the cleat of

FIG. 1 with only the B electrode illustrated to assist the reader in identifying the features of the B electrode.

FIG. 4 is a perspective view of the cleat of FIG. 1.

FIG. 5 is an illustration showing the concepts of radial (R) and circumferential (C) in the context of a non-circular geometry (G).

[0005] FIGS. 1 and 2 show a physiological monitor 10 in an assembled or connected state and a disassembled or disconnected state respectively and also show lateral, longitudinal, and transverse reference axes 14, 16, 18. The monitor includes a cleat 20 adapted to be securable to a subject, such as a patient. The illustrated cleat includes an adhesive layer 22 (shown only in FIG. 1) for securing the cleat to a patient. As seen best in FIGS. 3A and 3B, the cleat includes a pair of cleat electrodes 26A, 26B which are referred to herein as A and B electrodes. In one embodiment the electrodes are electrocardiogram (EKG) electrodes. In another embodiment the electrodes are excitation and sensing electrodes of the type employed in impedance electrocardiography.

[0006] As seen best in FIGS. 3A and 4, A electrode 26A includes an A electrode connector portion 28A and an arcuate A contact portion 30A. Contact portion 30A is the portion of the A electrode intended to be in contact with the patient.

[0007] Referring additionally to FIG. 3B, B electrode 26B includes a B electrode connector portion 28B and an arcuate B contact portion 30B. Contact portion 30B is the portion of the B electrode intended to be in contact with the patient.

[0008] In embodiments in which the electrode contact portions 30A, 30B are EKG electrodes, the contact portions may hydrogel contact portions.

[0009] The A and B electrode connector portions 28A, 28B are radially spaced from each other. The A electrode connector portion 28A is radially inboard of the B electrode connector portion 28B. The A electrode contact portion 30A is radially spaced from and radially outboard of the A electrode connector portion 28A. The B electrode contact portion 30B is radially spaced from and radially outboard of the B electrode connector portion 28B. In this specification, the use of the term "radial" and variants thereof is not intended to limit the form of any component to a circular shape, such as that seen in FIG. 3. Instead, "radial" is used to describe spatial relationships relative to a reference point or axis, such as axis 34. The terms "inboard", "outboard" and their variants are used to describe locations which are respectively closer to or more distant from a reference axis or reference point. The use of "circumferential" and its variants in this specification is also not intended to limit the form of any component to a circular shape. FIG. 5 shows the concepts of radial (R) and circumferential (C) in the context of a noncircular geometry (G).

[0010] A cleat O-ring seat **40** resides radially between the *A* and *B* electrode connector portions **28A**, **28B**. A cleat O-ring **42** resides radially between *B* connector portion **28B** and contact portions **30A**, **30B**.

[0011] An *A* conductor element **38A** connects the *A* contact portion **30A** to the *A* connector portion **28A** in order to convey signals between contact portion **30A** and connector portion **28A**. A *B* conductor element **38B** connects the *B* contact portion **30B** to the *B* connector portion **28B** in order to convey signals between contact portion **30B** and connector portion **28B**. As illustrated, conductor elements **38A**, **38B** are considerably more localized than the connector and contact portions **28A**, **28B**, **30A**, **30B**, all of which have a substantial circumferential spread. Nevertheless, conductor elements **38A**, **38B** could be more circumferentially extensive than those illustrated.

[0012] The monitor also includes an equipment module **50** removably attached to or removably attachable to the cleat as described in more detail below. Equipment module **50** includes electronic components of the monitor housed in an equipment compartment **52**. The electronic components may include at least a processor for processing data signals from electrodes **26A**, **26B** and from one or more sensors other than the electrodes (described below). The compartment may also house one or more amplifiers, one or more filters to amplify and denoise the sensor and electrode signals, and a transceiver to provides communication with remote devices such as information displays and user controls. The compartment may also house a battery. Further examples of equipment modules, cleats, and their architectures may be found in US provisional patent applications 62/588,598 filed on Nov. 20, 2017, 62/592,602 filed on Nov. 30, 2017, 62/618,772 filed on Jan. 18, 2018, and 62/607,646 filed on Dec. 19, 2017. The contents of the foregoing applications are incorporated herein by reference.

[0013] Equipment module **50** has an *A* module connector portion **58A** and a *B* module connector portion **58B**. The *A* module connector portion **58A** is radially inboard of the *B* module connector portion **58B**. As a result the *A* and *B* module connector portions **58A**, **58B** connect respectively with the *A* and *B* electrode connector portions **28A**, **28B** of the cleat when the equipment module is connected to the cleat as in FIG. 2. In the illustrated embodiment the *A* module connector portion **58A** and the *A* electrode connector portion **28A** are adapted to mate or connect with each other by being in mutual contact. The mutual contact establishes an *A* signal connection and resultant signal communication between the cleat and the equipment module, but does not establish a mechanical connection between the cleat and the equipment module. Likewise the *B* module connector portion **58B** and the *B* electrode connector portion **28B** are adapted to connect with each other by being in mutual contact thereby establishing a *B* signal connection and resultant signal communication, but not a mechanical connection, between the cleat and the equipment module. Mechanical connection is provided by mechanical

connector elements described below.

[0014] An equipment module O-ring **44** resides radially between module connector portions **58A**, **58B**. An equipment module O-ring seat **46** resides radially outboard of *B* module connector portion **58B**. When the equipment module is connected to the cleat as seen in FIG. 2, cleat O-ring **42** fits into module O-ring seat **46**, and module O-ring **44** fits into cleat O-ring seat **40**.

[0015] Equipment module **50** includes a module mechanical connector element **62** which extends transversely from the *A* module connector portion **58A**. The illustrated connector element **62** comprises two cylindrical sections **64**, **66** and an intervening ring **68** whose diameter is greater than that of the cylindrical sections.

[0016] Cleat **20** includes a cleat mechanical connector element **72** which extends transversely from *A* electrode connector portion **28A**. The illustrated connector element **72** comprises two cylindrical sections **74**, **76** and an intervening groove **78** with a diameter greater than that of the cylindrical sections. The module and cleat mechanical connector elements are adapted to mate with each other to affect a mechanical connection between cleat **20** and equipment module **50**. In particular ring **68** snaps into groove **78** to affect the mechanical connection. The ring is also separable from the groove so that the equipment module can be detached from the cleat. As noted earlier in this specification, the fact that the equipment module is attachable to and detachable from cleat allows the equipment module to be temporarily removed from the cleat when the patient participates in activities that could cause damage to components of the equipment module. The equipment module can be subsequently re-attached to the cleat.

[0017] In the illustrated embodiment the mechanical connection between the cleat and the equipment module is distinct from the *A* signal connection defined by the *A* connector portions **28A**, **58A** of the cleat electrodes and the equipment module and is also distinct from the *B* signal connection defined by the *B* connector portions **28B**, **58B** of the cleat electrodes and the equipment module.

[0018] When the cleat and equipment module are connected to each other as seen in FIG. 2, The *A* and *B* electrode contact portions **30A**, **30B** are radially outboard of both the electrode *A* and *B* connector portions **28A**, **28B** and the *A* and *B* equipment module connector portions **58A**, **58B**.

[0019] In the specific embodiment shown in the drawings the *A* and *B* electrode connector portions **28A**, **28B** are circumferentially complete, i.e. they extend circumferentially 360 degrees to define an *A* signal connector ring **28A** and a *B* signal connector ring **28B** which circumscribes the *A* signal connector ring. The *A* cleat contact portion **30A** is radially spaced from and is in signal communication, by way of conductor **38A**, with the *A* cleat signal connector ring **28A**. The *B* cleat contact portion **30B** is radially spaced from and is in signal communication by way of conductor **38B**, with the *B* cleat signal

connector ring **28B**. The *A* and *B* module connector portions **58A**, **58B** are also complete signal connector rings arranged so that the *B* module signal connector ring **58B** circumscribes the *A* module signal connector ring **58A**.

[0020] Referring to FIG. 2, the *A* cleat signal connector ring **28A** and the *A* module signal connector ring **58A** have similar frustoconical profiles having a virtual vertex **82A**. The *B* cleat signal connector ring **28B** and the *B* module signal connector ring **58B** also have similar frustoconical profiles having a virtual vertex **82B**. (In the illustration the conical profiles are represented by the interface between rings **28A** and **28B** and the interface between rings **58A** and **58B**, hence the presence of only a single apex on each side of the monitor.) "Similar" is used in the geometric sense of having the same shape. When the equipment module is connected to the cleat the apexes **82A**, **82B** are transversely separated from each other on opposite sides of center plane **P**. The *A* module signal connector ring **58A** nests radially inside the *A* cleat signal connector ring **28A**, and the *B* cleat signal connector ring **28B** nests radially inside the *B* module connector ring **58B**.

[0021] As seen in FIG. 1, cleat **20** includes a cleat sensor opening **84** radially inboard of cleat *A* electrode connector portion **28A**. Equipment module **50** includes a module sensor opening **86** radially inboard of the *A* module connector portion **58A**. When the cleat is assembled to the module as seen in FIG. 2, connector portions **84**, **86** define a monitor sensor opening **88**. In the specific embodiment in which the *A* module connector portion is a full ring **58A**, the ring is the border of opening **88**. The sensor opening is provided to accommodate sensors other than the electrodes **26A**, **26B**. Examples of such sensors include photoplethysmogram (PPG) sensors, phonocardiogram (PCG) sensors, and oxygen saturation (SpO₂) sensors.

[0022] The monitor is in the assembled state of FIG. 2 when it is being used to monitor the physiological signs of a patient. The cleat and equipment module are in signal communication with each other by way of an *A* signal connection established by the *A* electrode connector portion **28A** and the *A* module connector portion **58A** and by the *B* electrode connector portion **28B** and the *B* module connector portion **58B**. The equipment module **50** is detachable from the cleat **20** in the transverse direction, as indicated by arrow **T_D** in FIG. 1, so that the patient may participate in activities which might be harmful to components of the detachable equipment module. When the activity is finished the equipment module can be reconnected to the cleat in direction **T_A** to reproduce the assembled state of FIG. 1.

[0023] Although this disclosure refers to specific embodiments, it will be understood by those skilled in the art that various changes in form and detail may be made

[0024] Embodiments of the invention can be described with reference to the following numbered clauses, with preferred features laid out in the dependent clauses:

1. A physiological monitor comprising:

a cleat adapted to be securable to a subject, the cleat having an *A* electrode which includes an *A* electrode connector portion and a *B* electrode which includes a *B* electrode connector portion, the *A* and *B* connector portions being radially spaced from each other;

an equipment module removably attached or removably attachable to the cleat in a transverse direction, the module having an *A* module connector portion and a *B* module connector portion arranged such that the *A* and *B* module connector portions connect with the *A* and *B* electrode connector portions respectively when the equipment module is connected to the cleat.

2. The monitor of clause 1 wherein the *A* and *B* electrodes each include respective *A* and *B* contact portions adapted to contact the subject.

3. The monitor of either clause 1 or clause 2 wherein the *A* and *B* electrodes are *A* and *B* EKG electrodes.

4. The monitor of clause 3 wherein one of the *A* and *B* electrodes is an excite electrode and the other is a sense electrode.

5. The monitor of any preceding clause wherein the *A* and *B* electrode connector portions are circumferentially complete.

6. The monitor of clause 5 wherein the cleat includes a sensor opening radially inboard of the *A* electrode connector portion.

7. The monitor of clause 6 wherein the *A* electrode connector portion is a ring.

8. The monitor of any preceding clause wherein:

the *A* electrode connector portion and the *A* module connector portion define an *A* signal connection between the cleat and the module; the *B* electrode connector portion and the *B* module connector portion define a *B* signal connection between the cleat and the module; the cleat includes a cleat mechanical connector element;

the equipment module includes a module mechanical connector element; and the cleat and module mechanical connector elements are adapted to mate with each other to affect a mechanical connection between the cleat and the equipment module which is distinct from the signal connections.

9. A physiological monitor comprising:

a radially extending cleat having:

an *A* electrode comprised of an *A* electrode connector portion and an *A* contact portion which is radially outboard of the *A* electrode connector portion; and
 a *B* electrode comprised of a *B* electrode connector portion and a *B* contact portion which is radially outboard of the *B* electrode connector portion; and

an equipment module having:

an *A* module connector portion; and
 a *B* module connector portion;

wherein the *A* module connector portion and the *A* electrode connector portion are adapted to contact each other, and the *B* module connector portion and the *B* electrode connector portion are adapted to contact each other.

10. The monitor of clause **9** wherein when the cleat and module are connected to each other the *A* electrode connector portion is radially inboard of the *B* electrode connector portion, and the *A* module connector portion is radially inboard of the *B* module connector portion.

11. The monitor of clause **10** wherein when the cleat and module are connected to each other the *A* and *B* electrode contact portions are radially outboard of both the electrode *A* and *B* connector portions and the *A* and *B* equipment module connector portions.

12. The monitor of any one of clauses **9** to **11** wherein:

the *A* electrode connector portion mates with the *A* module connector portion to define an *A* signal connection between the cleat and the module; the *B* electrode connector portion mates with the *B* module connector portion to define a *B* signal connection between the cleat and the module; the cleat includes a cleat mechanical connector element; the equipment module includes a module mechanical connector element; and the cleat and module mechanical connector elements are adapted to mate with each other to effect a mechanical connection between the cleat and the equipment module which is distinct from the signal connections.

13. A vital signs monitor comprising:

a cleat having:

an *A* cleat signal connector ring;
 a *B* cleat signal connector ring circumscribing the *A* cleat signal connector ring;
 an *A* cleat contact element radially spaced from and in signal communication with the *A* cleat signal connector ring;
 a *B* cleat contact element radially spaced from and in signal communication with the *B* cleat signal connector ring;
 a cleat mechanical connector element; and

an equipment module having:

an *A* module signal connector ring;
 a *B* module signal connector ring circumscribing the *A* module signal connector ring;
 a module mechanical connector element;

wherein the cleat and equipment module are connectable to an disconnectable from each other in a transverse direction.

14. The monitor of clause **13** wherein when the cleat and module are connected to each other:

the *A* cleat signal connector ring is in contact with the *A* module signal connector ring thereby establishing an *A* signal connection between the cleat and the module;
 the *B* cleat signal connector ring is in contact with the *B* module signal connector ring thereby establishing a *B* signal connection between the cleat and the module; and
 the cleat mechanical connector element and the module mechanical connector element are mated with each other to establish a mechanical connection between the cleat and the module.

15. The monitor of either clause **13** or clause **14** wherein the *A* cleat signal connector ring and the *A* module signal connector ring have similar frustoconical profiles.

16. The monitor of any one of clauses **13** to **15** wherein the *B* cleat signal connector ring and the *B* module signal connector ring have similar frustoconical profiles.

17. The monitor of any one of clauses **13** to **16** wherein:

the *A* cleat signal connector ring and the *A* module signal connector ring have similar frustoconical profiles having *A* apexes;
 the *B* cleat signal connector ring and the *B* module signal connector ring have similar frustoconical profiles having *B* apexes; and
 when the cleat and module are connected to

each other the *A* apexes lie on one side of a laterally and longitudinally extending center-plane and the *B* apexes lie on the other side of the laterally and longitudinally extending center plane.

18. The monitor of clause **17** wherein when the cleat and the module are connected to each other:

the *A* module signal connector ring nests radially inside the *A* cleat signal connector ring; and the *B* cleat signal connector ring nests radially inside the *B* module connector ring.

19. The module of any one of clauses **13** to **18** wherein the *A* and *B* cleat contact elements have an arcuate profile.

Claims

1. A physiological monitor comprising:

a cleat adapted to be securable to a subject, the cleat having an *A* electrode which includes an *A* electrode connector portion and a *B* electrode which includes a *B* electrode connector portion, the *A* and *B* connector portions being radially spaced from each other; an equipment module removably attached or removably attachable to the cleat in a transverse direction, the module having an *A* module connector portion and a *B* module connector portion arranged such that the *A* and *B* module connector portions connect with the *A* and *B* electrode connector portions respectively when the equipment module is connected to the cleat.

2. The monitor of claim **1** wherein the *A* and *B* electrodes each include respective *A* and *B* contact portions, adapted to contact the subject.

3. The monitor of either claim **1** or claim **2** wherein the *A* and *B* electrodes are *A* and *B* EKG electrodes.

4. The monitor of claim **3** wherein one of the *A* and *B* electrodes is an excite electrode and the other is a sense electrode.

5. The monitor of any preceding claim wherein the *A* and *B* electrode connector portions are circumferentially complete.

6. The monitor of claim **5** wherein the cleat includes a sensor opening radially inboard of the *A* electrode connector portion.

7. The monitor of claim **6** wherein the *A* electrode con-

connector portion is a ring.

8. The monitor of any preceding claim wherein:

the *A* electrode connector portion and the *A* module connector portion define an *A* signal connection between the cleat and the module; the *B* electrode connector portion and the *B* module connector portion define a *B* signal connection between the cleat and the module; the cleat includes a cleat mechanical connector element; the equipment module includes a module mechanical connector element; and the cleat and module mechanical connector elements are adapted to mate with each other to effect a mechanical connection between the cleat and the equipment module which is distinct from the signal connections.

9. The physiological monitor of any preceding claim wherein:

the *A* electrode includes an *A* contact portion which is radially outboard of the *A* electrode connector portion; and the *B* electrode includes a *B* contact portion which is radially outboard of the *B* electrode connector portion.

10. The monitor of claim **9** wherein when the cleat and module are connected to each other the *A* electrode connector portion is radially inboard of the *B* electrode connector portion, and the *A* module connector portion is radially inboard of the *B* module connector portion.

11. The monitor of claim **10** wherein when the cleat and module are connected to each other the *A* and *B* electrode contact portions are radially outboard of both the electrode *A* and *B* connector portions and the *A* and *B* equipment module connector portions.

12. The monitor of any one of claims **9** to **11** wherein:

the *A* electrode connector portion mates with the *A* module connector portion to define an *A* signal connection between the cleat and the module; the *B* electrode connector portion mates with the *B* module connector portion to define a *B* signal connection between the cleat and the module; the cleat includes a cleat mechanical connector element; the equipment module includes a module mechanical connector element; and the cleat and module mechanical connector elements are adapted to mate with each other to effect a mechanical connection between the

cleat and the equipment module which is distinct from the signal connections.

13. The monitor of any one of claims 9 to 12 wherein the A electrode connector portion and the A module connector portion are rings having similar frustoconical profiles and the B electrode connector portion and the B module connector portion are also rings having similar frustoconical profiles.

5
10

14. The monitor of claim 13 wherein:

the similar frustoconical profiles of the A connector rings have A apexes;
the similar frustoconical profiles of the B connector rings have B apexes; and
when the cleat and module are connected to each other the A apexes lie on one side of a laterally and longitudinally extending center-plane and the B apexes lie on the other side of the laterally and longitudinally extending center plane.

15
20

15. The monitor of claim 14 wherein when the cleat and the module are connected to each other:

25

the A module connector ring nests radially inside the A cleat electrode connector ring; and
the B electrode connector ring nests radially inside the B module connector ring.

30

35

40

45

50

55

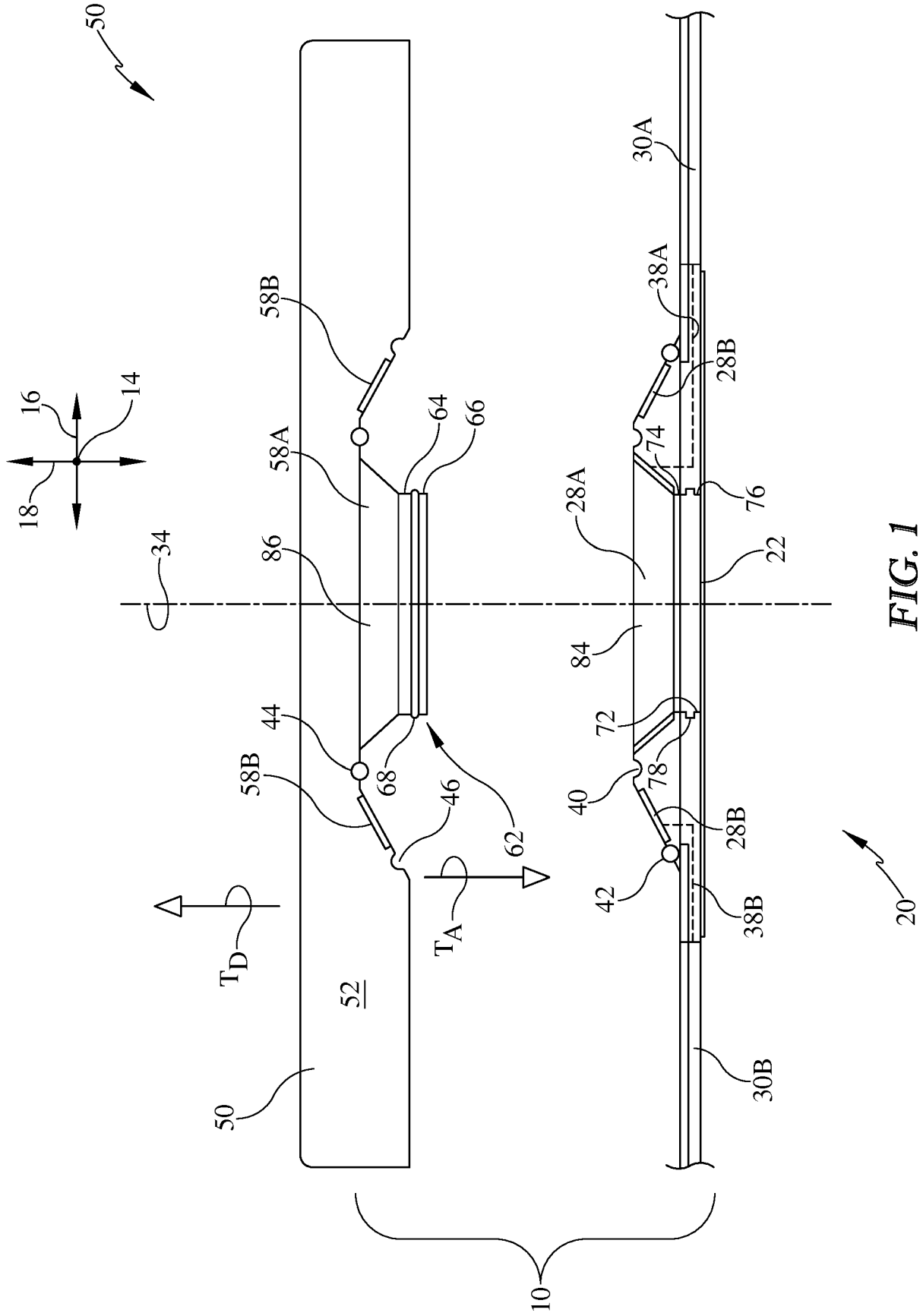

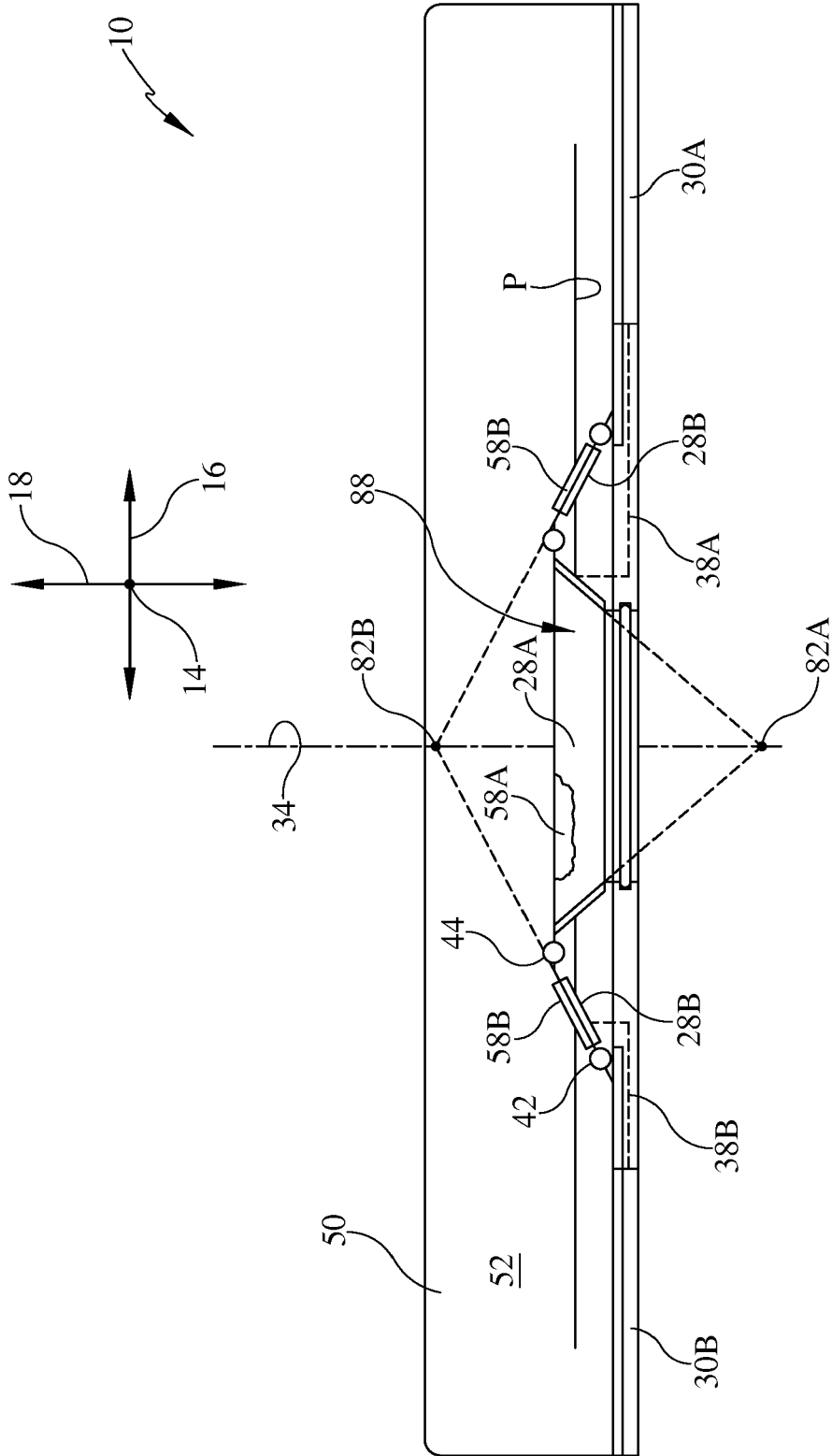

FIG. 2

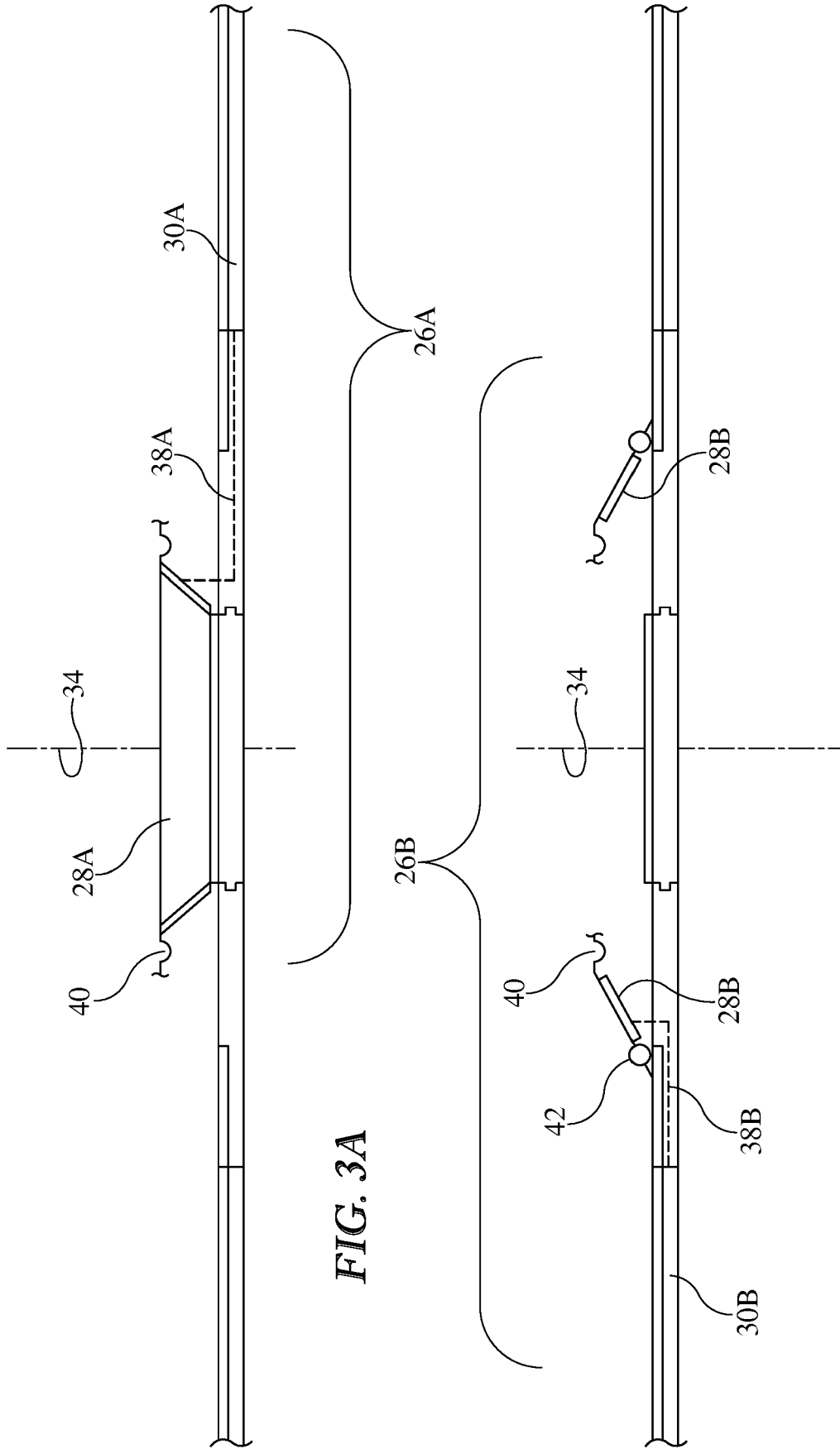

FIG. 3A

FIG. 3B

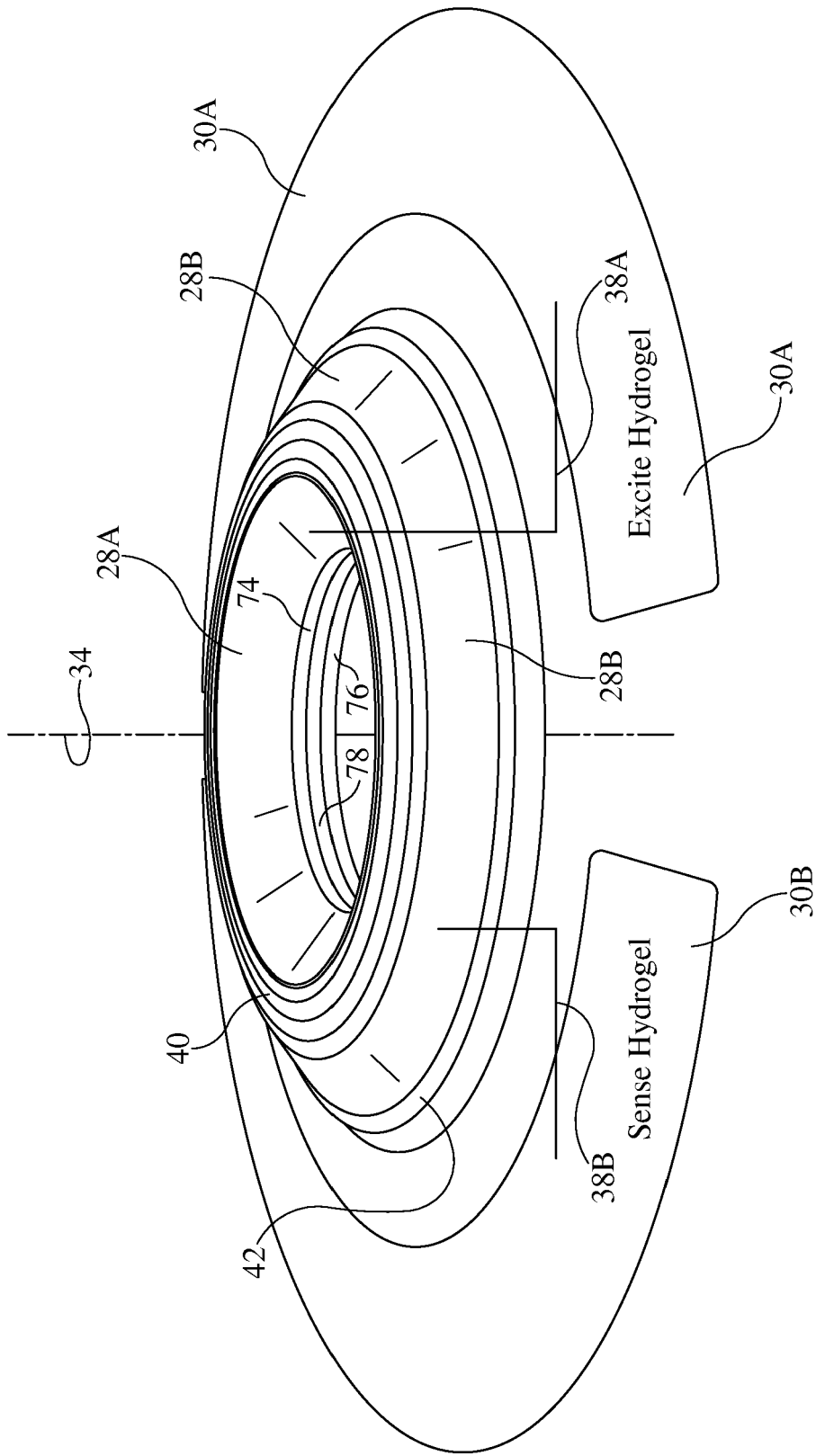

FIG. 4

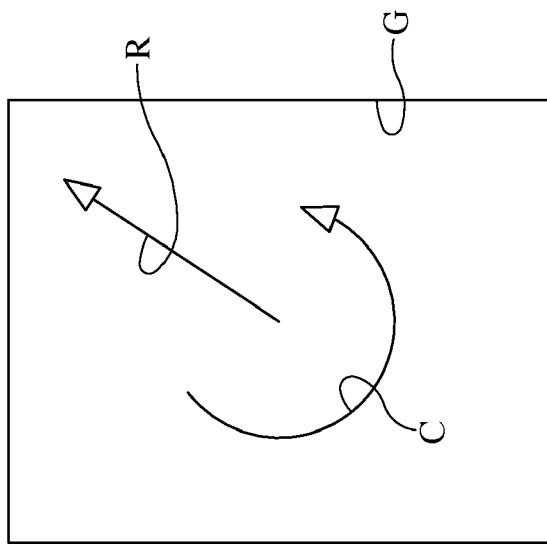

FIG. 5



EUROPEAN SEARCH REPORT

Application Number
EP 19 15 2859

5

10

15

20

25

30

35

40

45

50

55

DOCUMENTS CONSIDERED TO BE RELEVANT			
Category	Citation of document with indication, where appropriate, of relevant passages	Relevant to claim	CLASSIFICATION OF THE APPLICATION (IPC)
X	US 2008/288026 A1 (CROSS BRETT [US] ET AL) 20 November 2008 (2008-11-20) * the whole document * -----	1-4,8-12	INV. A61B5/0408 A61B5/00
X	US 2008/114220 A1 (BANET MATTHEW JOHN [US] ET AL) 15 May 2008 (2008-05-15) * paragraph [0012] - paragraph [0020] * * paragraph [0034] - paragraph [0038] * * figures 1-3 *	1-15	
X	US 2012/226128 A1 (SHIN KUN SOO [KR] ET AL) 6 September 2012 (2012-09-06) * paragraph [0068] - paragraph [0083] * * figures 7,8 * -----	1-4	
The present search report has been drawn up for all claims			TECHNICAL FIELDS SEARCHED (IPC)
			A61B
Place of search		Date of completion of the search	Examiner
Berlin		15 April 2019	Abraham, Volkhard
CATEGORY OF CITED DOCUMENTS			
X : particularly relevant if taken alone Y : particularly relevant if combined with another document of the same category A : technological background O : non-written disclosure P : intermediate document		T : theory or principle underlying the invention E : earlier patent document, but published on, or after the filing date D : document cited in the application L : document cited for other reasons & : member of the same patent family, corresponding document	

EPO FORM 1503 03 82 (P04C01)

ANNEX TO THE EUROPEAN SEARCH REPORT
ON EUROPEAN PATENT APPLICATION NO.

EP 19 15 2859

5 This annex lists the patent family members relating to the patent documents cited in the above-mentioned European search report.
The members are as contained in the European Patent Office EDP file on
The European Patent Office is in no way liable for these particulars which are merely given for the purpose of information.

15-04-2019

Patent document cited in search report	Publication date	Patent family member(s)	Publication date
US 2008288026 A1	20-11-2008	CN 101321494 A	10-12-2008
		EP 1956973 A1	20-08-2008
		JP 2009517160 A	30-04-2009
		US 2008288026 A1	20-11-2008
		WO 2007063436 A1	07-06-2007

US 2008114220 A1	15-05-2008	US 2008114220 A1	15-05-2008
		US 2013109937 A1	02-05-2013

US 2012226128 A1	06-09-2012	EP 1776922 A1	25-04-2007
		US 2007093705 A1	26-04-2007
		US 2010049028 A1	25-02-2010
		US 2012226128 A1	06-09-2012

REFERENCES CITED IN THE DESCRIPTION

This list of references cited by the applicant is for the reader's convenience only. It does not form part of the European patent document. Even though great care has been taken in compiling the references, errors or omissions cannot be excluded and the EPO disclaims all liability in this regard.

Patent documents cited in the description

- US 62588598 B [0012]
- US 62592602 B [0012]
- US 62618772 B [0012]
- US 62607646 B [0012]

专利名称(译)	带有防滑钉的生理参数监视器和可拆卸地连接到防滑钉的设备模块		
公开(公告)号	EP3517030A1	公开(公告)日	2019-07-31
申请号	EP2019152859	申请日	2019-01-21
[标]申请(专利权)人(译)	伟伦公司		
申请(专利权)人(译)	伟伦, INC.		
当前申请(专利权)人(译)	伟伦, INC.		
[标]发明人	MARTIN SCOTT A FITCH TIMOTHY R		
发明人	SUAREZ, CARLOS A MARTIN, SCOTT A WAWRO, THADDEUS J FITCH, TIMOTHY R		
IPC分类号	A61B5/0408 A61B5/00		
CPC分类号	A61B5/04087 A61B5/6813 A61B5/6832 A61B5/0408 A61B5/6801		
优先权	62/621232 2018-01-24 US		
外部链接	Espacenet		

摘要(译)

生理监测器包括适于固定到诸如患者的对象的防滑钉。防滑钉包括A电极，该A电极包括A电极连接器部分。防滑钉还包括B电极，其包括B电极连接器部分。设备模块在横向方向上可拆卸地连接或可拆卸地连接到防滑板。设备模块具有A模块连接器部分和B模块连接器部分，其布置成使得当设备模块连接到防滑板时A和B模块连接器部分分别与A和B电极连接器部分连接，从而放置防滑钉和设备模块在信号通信中相互通信。

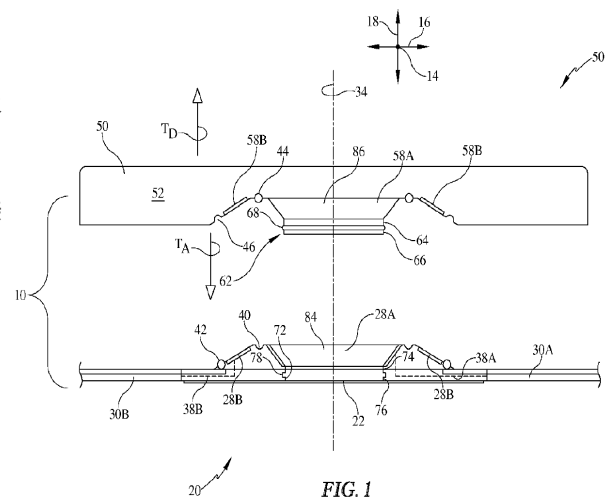

FIG. 1