

(19)



(11)

EP 2 305 104 B1

(12)

EUROPEAN PATENT SPECIFICATION

(45) Date of publication and mention of the grant of the patent:
17.10.2018 Bulletin 2018/42

(51) Int Cl.:
A61B 5/00 (2006.01)

(21) Application number: **10193356.2**

(22) Date of filing: **01.03.2006**

(54) Multiple wavelength sensor drivers

Sensortreiber mit mehreren Wellenlängen

Pilotes de capteur à plusieurs longueurs d'onde

(84) Designated Contracting States:
AT BE BG CH CY CZ DE DK EE ES FI FR GB GR HU IE IS IT LI LT LU LV MC NL PL PT RO SE SI SK TR

(30) Priority: **01.03.2005 US 657596 P**
01.03.2005 US 657759 P
01.03.2005 US 657268 P
01.03.2005 US 657281 P

(43) Date of publication of application:
06.04.2011 Bulletin 2011/14

(62) Document number(s) of the earlier application(s) in accordance with Art. 76 EPC:
06736800.1 / 1 860 996

(73) Proprietor: **Masimo Laboratories, Inc.**
Irvine, CA 92618 (US)

(72) Inventors:

- **Al-Ali, Ammar**
San Juan Capistrano, CA 92675 (US)
- **Smith, Robert**
Lake Forest, CA92630 (US)
- **Dalke, David**
Irvine, CA 92630 (US)
- **Lamego, Marcelo**
Santa Margarita, CA 92688 (US)
- **Diab, Mohamed**
Ladera Ranch, CA92694 (US)

(74) Representative: **Vossius & Partner**
Patentanwälte Rechtsanwälte mbB
Siebertstrasse 3
81675 München (DE)

(56) References cited:

US-A- 5 827 182	US-A- 6 165 005
US-A1- 2002 183 819	US-A1- 2004 147 823
US-B1- 6 184 521	

EP 2 305 104 B1

Note: Within nine months of the publication of the mention of the grant of the European patent in the European Patent Bulletin, any person may give notice to the European Patent Office of opposition to that patent, in accordance with the Implementing Regulations. Notice of opposition shall not be deemed to have been filed until the opposition fee has been paid. (Art. 99(1) European Patent Convention).

Description

BACKGROUND OF THE INVENTION

[0001] Spectroscopy is a common technique for measuring the concentration of organic and some inorganic constituents of a solution. The theoretical basis of this technique is the Beer-Lambert law, which states that the concentration c_i of an absorbent in solution can be determined by the intensity of light transmitted through the solution, knowing the pathlength d_λ , the intensity of the incident light $I_{0,\lambda}$, and the extinction coefficient $\epsilon_{i,\lambda}$ at a particular wavelength λ . In generalized form, the Beer-Lambert law is expressed as:

$$I_\lambda = I_{0,\lambda} e^{-d_\lambda \cdot \mu_{a,\lambda}} \quad (1)$$

$$\mu_{a,\lambda} = \sum_{i=1}^n \epsilon_{i,\lambda} \cdot c_i \quad (2)$$

where $\mu_{a,\lambda}$ is the bulk absorption coefficient and represents the probability of absorption per unit length. The minimum number of discrete wavelengths that are required to solve EQS. 1-2 are the number of significant absorbers that are present in the solution.

[0002] A practical application of this technique is pulse oximetry, which utilizes a noninvasive sensor to measure oxygen saturation (SpO₂) and pulse rate. In general, the sensor has light emitting diodes (LEDs) that transmit optical radiation of red and infrared wavelengths into a tissue site and a detector that responds to the intensity of the optical radiation after absorption (e.g., by transmission or transreflectance) by pulsatile arterial blood flowing within the tissue site. Based on this response, a processor determines measurements for SpO₂, pulse rate, and can output representative plethysmographic waveforms. Thus, "pulse oximetry" as used herein encompasses its broad ordinary meaning known to one of skill in the art, which includes at least those noninvasive procedures for measuring parameters of circulating blood through spectroscopy. Moreover, "plethysmograph" as used herein (commonly referred to as "photoplethysmograph"), encompasses its broad ordinary meaning known to one of skill in the art, which includes at least data representative of a change in the absorption of particular wavelengths of light as a function of the changes in body tissue resulting from pulsing blood. Pulse oximeters capable of reading through motion induced noise are available from Masimo Corporation ("Masimo") of Irvine, California. Moreover, portable and other oximeters capable of reading through motion induced noise are disclosed in at least U.S. Pat. Nos. 6,770,028, 6,658,276,

6,157,850, 6,002,952, 5,769,785, and 5,758,644, which are owned by Masimo and are incorporated by reference herein. Such reading through motion oximeters have gained rapid acceptance in a wide variety of medical applications, including surgical wards, intensive care and neonatal units, general wards, home care, physical training, and virtually all types of monitoring scenarios.

SUMMARY OF THE INVENTION

[0003] There is a need to noninvasively measure multiple physiological parameters, other than, or in addition to, oxygen saturation and pulse rate. For example, hemoglobin species that are also significant under certain circumstances are carboxyhemoglobin and methemoglobin. Other blood parameters that may be measured to provide important clinical information are fractional oxygen saturation, total hemoglobin (Hbt), bilirubin and blood glucose, to name a few.

[0004] One aspect of a sensor driver is a cable capable of communicating signals between a physiological sensor and a monitor is a first row input, a first column input, a second row input and a second column input. The cable is capable of activating individual light emitters of an emitter array arranged in an electrical grid by driving at least one row drive line and at least one column drive line of the electrical grid. A first output combines the first row input and the first column input. A second output combines the second row input and the second column input. The inputs are adapted to connect to electrical grid drive lines of a monitor. Further, the outputs are adapted to connect to contacts of a physiological sensor having back-to-back configured LEDs in electrical communication with the contacts.

[0005] Another aspect of a sensor driver is an electrical grid configured to activate light emitting sources by addressing at least one row conductor and at least one column conductor. A first LED and a second LED are configured in a back-to-back arrangement so that a first contact is connected to a first LED cathode and a second LED anode and a second contact is connected to a first LED anode and a second LED cathode. The first contact is in communications with a first row conductor and a first column conductor. The second contact is in communications with a second row conductor and a second column conductor. Further, the first LED is activated by addressing the first row conductor and the second column conductor and the second LED is activated by addressing the second row conductor and the first column conductor.

[0006] A further aspect of a sensor driver is an electrical grid drive having at least a portion of the electrical grid drive communicated to a physiological sensor. The electrical grid drive is adapted to activate back-to-back configured LEDs. The invention is defined in the claims. All embodiments not falling under the scope of the claims are merely examples and are not part of the present invention.

BRIEF DESCRIPTION OF THE DRAWINGS**[0007]**

FIG. 1 is a perspective view of a physiological measurement system utilizing a multiple wavelength sensor;

FIGS. 2A-C are perspective views of multiple wavelength sensor embodiments;

FIG. 3 is a general block diagram of a multiple wavelength sensor and sensor controller;

FIG. 4 is an exploded perspective view of a multiple wavelength sensor embodiment;

FIG. 5 is a general block diagram of an emitter assembly;

FIG. 6 is a perspective view of an emitter assembly embodiment;

FIG. 7 is a general block diagram of an emitter array;

FIG. 8 is a schematic diagram of an emitter array embodiment;

FIG. 9 is a general block diagram of equalization;

FIGS. 10A-D are block diagrams of various equalization embodiments;

FIGS. 11A-C are perspective views of an emitter assembly incorporating various equalization embodiments;

FIG. 12 is a general block diagram of an emitter substrate;

FIGS. 13-14 are top and detailed side views of an emitter substrate embodiment;

FIG. 15-16 are top and bottom component layout views of an emitter substrate embodiment;

FIG. 17 is a schematic diagram of an emitter substrate embodiment;

FIG. 18 is a plan view of an inner layer of an emitter substrate embodiment;

FIG. 19 is a general block diagram of an interconnect assembly in relationship to other sensor assemblies;

FIG. 20 is a block diagram of an interconnect assembly embodiment;

FIG. 21 is a partially-exploded perspective view of a flex circuit assembly embodiment of an interconnect assembly;

FIG. 22 is a top plan view of a flex circuit;

FIG. 23 is an exploded perspective view of an emitter portion of a flex circuit assembly;

FIG. 24 is an exploded perspective view of a detector assembly embodiment;

FIGS. 25-26 are block diagrams of adjacent detector and stacked detector embodiments;

FIG. 27 is a block diagram of a finger clip embodiment of an attachment assembly;

FIG. 28 is a general block diagram of a detector pad;

FIGS. 29A-B are perspective views of detector pad embodiments;

FIGS. 30A-H are perspective bottom, perspective top, bottom, back, top, side cross sectional, side, and front cross sectional views of an emitter pad embod-

iment;

FIGS. 31A-H are perspective bottom, perspective top, top, back, bottom, side cross sectional, side, and front cross sectional views of a detector pad embodiment;

FIGS. 32A-H are perspective bottom, perspective top, top, back, bottom, side cross sectional, side, and front cross sectional views of a shoe box;

FIGS. 33A-H are perspective bottom, perspective top, top, back, bottom, side cross sectional, side, and front cross sectional views of a slim-finger emitter pad embodiment;

FIGS. 34A-H are perspective bottom, perspective top, top, back, bottom, side cross sectional, side, and front cross sectional views of a slim-finger detector pad embodiment;

FIGS. 35A-B are plan and cross sectional views, respectively, of a spring assembly embodiment;

FIGS. 36A-C are top, perspective and side views of a finger clip spring;

FIGS. 37A-D are top, back, bottom, and side views of a spring plate;

FIGS. 38A-D are front cross sectional, bottom, front and side cross sectional views of an emitter-pad shell;

FIGS. 39A-D are back, top, front and side cross sectional views of a detector-pad shell;

FIG. 40 is a general block diagram of a monitor and a sensor;

FIGS. 41A-C are schematic diagrams of grid drive embodiments for a sensor having back-to-back diodes and an information element;

FIGS. 42 is a schematic diagrams of a grid drive embodiment for an information element;

FIGS. 43A-C are schematic diagrams for grid drive readable information elements;

FIGS. 44A-B are cross sectional and side cut away views of a sensor cable;

FIG. 45 is a block diagram of a sensor controller embodiment; and

FIG. 46 is a detailed exploded perspective view of a multiple wavelength sensor embodiment.

DETAILED DESCRIPTION OF THE PREFERRED EMBODIMENTSOverview

[0008] In this application, reference is made to many blood parameters. Some references that have common shorthand designations are referenced through such shorthand designations. For example, as used herein, HbCO designates carboxyhemoglobin, HbMet designates methemoglobin, and Hbt designates total hemoglobin. Other shorthand designations such as COHb, MetHb, and tHb are also common in the art for these same constituents. These constituents are generally reported in terms of a percentage, often referred to as sat-

uration, relative concentration or fractional saturation. Total hemoglobin is generally reported as a concentration in g/dL. The use of the particular shorthand designators presented in this application does not restrict the term to any particular manner in which the designated constituent is reported.

[0009] FIG. 1 illustrates a physiological measurement system 10 having a monitor 100 and a multiple wavelength sensor assembly 200 with enhanced measurement capabilities as compared with conventional pulse oximetry. The physiological measurement system 10 allows the monitoring of a person, including a patient. In particular, the multiple wavelength sensor assembly 200 allows the measurement of blood constituent and related parameters in addition to oxygen saturation and pulse rate. Alternatively, the multiple wavelength sensor assembly 200 allows the measurement of oxygen saturation and pulse rate with increased accuracy or robustness as compared with conventional pulse oximetry.

[0010] In one embodiment, the sensor assembly 200 is configured to plug into a monitor sensor port 110. Monitor keys 160 provide control over operating modes and alarms, to name a few. A display 170 provides readouts of measured parameters, such as oxygen saturation, pulse rate, HbCO and HbMet to name a few.

[0011] FIGS. 2A illustrates a multiple wavelength sensor assembly 200 having a sensor 400 adapted to attach to a tissue site, a sensor cable 4400 and a monitor connector 210. In one embodiment, the sensor 400 is incorporated into a reusable finger clip adapted to removably attach to, and transmit light through, a fingertip. The sensor cable 4400 and monitor connector 210 are integral to the sensor 400, as shown. In alternative embodiments, the sensor 400 may be configured separately from the cable 4400 and connector 210.

[0012] FIGS. 2B-C illustrate alternative sensor embodiments, including a sensor 401 (FIG. 2B) partially disposable and partially reusable (resposable) and utilizing an adhesive attachment mechanism. Also shown is a sensor 402 (FIG. 2C) being disposable and utilizing an adhesive attachment mechanism. In other embodiments, a sensor may be configured to attach to various tissue sites other than a finger, such as a foot or an ear. Also a sensor may be configured as a reflectance or transreflectance device that attaches to a forehead or other tissue surface.

[0013] FIG. 3 illustrates a sensor assembly 400 having an emitter assembly 500, a detector assembly 2400, an interconnect assembly 1900 and an attachment assembly 2700. The emitter assembly 500 responds to drive signals received from a sensor controller 4500 in the monitor 100 via the cable 4400 so as to transmit optical radiation having a plurality of wavelengths into a tissue site. The detector assembly 2400 provides a sensor signal to the monitor 100 via the cable 4400 in response to optical radiation received after attenuation by the tissue site. The interconnect assembly 1900 provides electrical communication between the cable 4400 and both the emitter assembly 500 and the detector assembly 2400.

The attachment assembly 2700 attaches the emitter assembly 500 and detector assembly 2400 to a tissue site, as described above. The emitter assembly 500 is described in further detail with respect to FIG. 5, below. The interconnect assembly 1900 is described in further detail with respect to FIG. 19, below. The detector assembly 2400 is described in further detail with respect to FIG. 24, below. The attachment assembly 2700 is described in further detail with respect to FIG. 27, below.

[0014] FIG. 4 illustrates a sensor 400 embodiment that removably attaches to a fingertip. The sensor 400 houses a multiple wavelength emitter assembly 500 and corresponding detector assembly 2400. A flex circuit assembly 1900 mounts the emitter and detector assemblies 500, 2400 and interconnects them to a multiwire sensor cable 4400. Advantageously, the sensor 400 is configured in several respects for both wearer comfort and parameter measurement performance. The flex circuit assembly 1900 is configured to mechanically decouple the cable 4400 wires from the emitter and detector assemblies 500, 2400 to reduce pad stiffness and wearer discomfort. The pads 3000, 3100 are mechanically decoupled from shells 3800, 3900 to increase flexibility and wearer comfort. A spring 3600 is configured in hinged shells 3800, 3900 so that the pivot point of the finger clip is well behind the fingertip, improving finger attachment and more evenly distributing the clip pressure along the finger.

[0015] As shown in FIG. 4, the detector pad 3100 is structured to properly position a fingertip in relationship to the detector assembly 2400. The pads have flaps that block ambient light. The detector assembly 2400 is housed in an enclosure so as to reduce light piping from the emitter assembly to the detector assembly without passing through fingertip tissue. These and other features are described in detail below. Specifically, emitter assembly embodiments are described with respect to FIGS. 5-18. Interconnect assembly embodiments, including the flexible circuit assembly 1900, are described with respect to FIGS. 19-23. Detector assembly embodiments are described with respect to FIGS. 24-26. Attachment assembly embodiments are described with respect to FIGS. 27-39.

Emitter Assembly

[0016] FIG. 5 illustrates an emitter assembly 500 having an emitter array 700, a substrate 1200 and equalization 900. The emitter array 700 has multiple light emitting sources, each activated by addressing at least one row and at least one column of an electrical grid. The light emitting sources are capable of transmitting optical radiation having multiple wavelengths. The equalization 900 accounts for differences in tissue attenuation of the optical radiation across the multiple wavelengths so as to at least reduce wavelength-dependent variations in detected intensity. The substrate 1200 provides a physical mount for the emitter array and emitter-related equalization and a connection between the emitter array and the

interconnection assembly. Advantageously, the substrate **1200** also provides a bulk temperature measurement so as to calculate the operating wavelengths for the light emitting sources. The emitter array **700** is described in further detail with respect to FIG. 7, below. Equalization is described in further detail with respect to FIG. 9, below. The substrate **1200** is described in further detail with respect to FIG. 12, below.

[0017] FIG. 6 illustrates an emitter assembly **500** embodiment having an emitter array **700**, an encapsulant **600**, an optical filter **1100** and a substrate **1200**. Various aspects of the emitter assembly **500** are described with respect to FIGS. 7-18, below. The emitter array **700** emits optical radiation having multiple wavelengths of predetermined nominal values, advantageously allowing multiple parameter measurements. In particular, the emitter array **700** has multiple light emitting diodes (LEDs) **710** that are physically arranged and electrically connected in an electrical grid to facilitate drive control, equalization, and minimization of optical pathlength differences at particular wavelengths. The optical filter **1100** is advantageously configured to provide intensity equalization across a specific LED subset. The substrate **1200** is configured to provide a bulk temperature of the emitter array **700** so as to better determine LED operating wavelengths.

Emitter Array

[0018] FIG. 7 illustrates an emitter array **700** having multiple light emitters (LE) **710** capable of emitting light **702** having multiple wavelengths into a tissue site **1**. Row drivers **4530** and column drivers **4560** are electrically connected to the light emitters **710** and activate one or more light emitters **710** by addressing at least one row **720** and at least one column **740** of an electrical grid. In one embodiment, the light emitters **710** each include a first contact **712** and a second contact **714**. The first contact **712** of a first subset **730** of light emitters is in communication with a first conductor **720** of the electrical grid. The second contact **714** of a second subset **750** of light emitters is in communication with a second conductor **740**. Each subset comprises at least two light emitters, and at least one of the light emitters of the first and second subsets **730**, **750** are not in common. A detector **2400** is capable of detecting the emitted light **702** and outputting a sensor signal **2500** responsive to the emitted light **702** after attenuation by the tissue site **1**. As such, the sensor signal **2500** is indicative of at least one physiological parameter corresponding to the tissue site **1**, as described above.

[0019] FIG. 8 illustrates an emitter array **700** having LEDs **801** connected within an electrical grid of n rows and m columns totaling $n + m$ drive lines **4501**, **4502**, where n and m integers greater than one. The electrical grid advantageously minimizes the number of drive lines required to activate the LEDs **801** while preserving flexibility to selectively activate individual LEDs **801** in any

sequence and multiple LEDs **801** simultaneously. The electrical grid also facilitates setting LED currents so as to control intensity at each wavelength, determining operating wavelengths and monitoring total grid current so as to limit power dissipation. The emitter array **700** is also physically configured in rows **810**. This physical organization facilitates clustering LEDs **801** according to wavelength so as to minimize pathlength variations and facilitates equalization of LED intensities.

[0020] As shown in FIG. 8, one embodiment of an emitter array **700** comprises up to sixteen LEDs **801** configured in an electrical grid of four rows **810** and four columns **820**. Each of the four row drive lines **4501** provide a common anode connection to four LEDs **801**, and each of the four column drive lines **4502** provide a common cathode connection to four LEDs **801**. Thus, the sixteen LEDs **801** are advantageously driven with only eight wires, including four anode drive lines **812** and four cathode drive lines **822**. This compares favorably to conventional common anode or cathode LED configurations, which require more drive lines. In a particular embodiment, the emitter array **700** is partially populated with eight LEDs having nominal wavelengths as shown in TABLE 1. Further, LEDs having wavelengths in the range of 610-630 nm are grouped together in the same row. The emitter array **700** is adapted to a physiological measurement system **10** (FIG. 1) for measuring H_bCO and/or METHb in addition to S_pO_2 and pulse rate.

TABLE 1: Nominal LED Wavelengths

LED	λ	Row	Col
D1	630	1	1
D2	620	1	2
D3	610	1	3
D4		1	4
D5	700	2	1
D6	730	2	2
D7	660	2	3
D8	805	2	4
D9		3	1
D10		3	2
D11		3	3
D12	905	3	4
D13		4	1
D14		4	2
D15		4	3
D16		4	4

[0021] Also shown in FIG. 8, row drivers **4530** and column drivers **4560** located in the monitor **100** selectively

activate the LEDs **801**. In particular, row and column drivers **4530**, **4560** function together as switches to Vcc and current sinks, respectively, to activate LEDs and as switches to ground and Vcc, respectively, to deactivate LEDs. This push-pull drive configuration advantageously prevents parasitic current flow in deactivated LEDs. In a particular embodiment, only one row drive line **4501** is switched to Vcc at a time. One to four column drive lines **4502**, however, can be simultaneously switched to a current sink so as to simultaneously activate multiple LEDs within a particular row. Activation of two or more LEDs of the same wavelength facilitates intensity equalization, as described with respect to FIGS. **9-11**, below. LED drivers are described in further detail with respect to FIG. **45**, below.

[0022] Although an emitter assembly is described above with respect to an array of light emitters each configured to transmit optical radiation centered around a nominal wavelength, in another embodiment, an emitter assembly advantageously utilizes one or more tunable broadband light sources, including the use of filters to select the wavelength, so as to minimize wavelength-dependent pathlength differences from emitter to detector. In yet another emitter assembly embodiment, optical radiation from multiple emitters each configured to transmit optical radiation centered around a nominal wavelength is funneled to a tissue site point so as to minimize wavelength-dependent pathlength differences. This funneling may be accomplished with fiberoptics or mirrors, for example. In further embodiments, the LEDs **801** can be configured with alternative orientations with correspondingly different drivers among various other configurations of LEDs, drivers and interconnecting conductors.

Equalization

[0023] FIG. **9** illustrate a physiological parameter measurement system **10** having a controller **4500**, an emitter assembly **500**, a detector assembly **2400** and a front-end **4030**. The emitter assembly **500** is configured to transmit optical radiation having multiple wavelengths into the tissue site **1**. The detector assembly **2400** is configured to generate a sensor signal **2500** responsive to the optical radiation after tissue attenuation. The front-end **4030** conditions the sensor signal **2500** prior to analog-to-digital conversion (ADC).

[0024] FIG. **9** also generally illustrates equalization **900** in a physiological measurement system **10** operating on a tissue site **1**. Equalization encompasses features incorporated into the system **10** in order to provide a sensor signal **2500** that falls well within the dynamic range of the ADC across the entire spectrum of emitter wavelengths. In particular, equalization compensates for the imbalance in tissue light absorption due to Hb and HbO₂ **910**. Specifically, these blood constituents attenuate red wavelengths greater than IR wavelengths. Ideally, equalization **900** balances this unequal attenuation. Equalization **900** can be introduced anywhere in the system **10**

from the controller **4500** to front-end **4000** and can include compensatory attenuation versus wavelength, as shown, or compensatory amplification versus or both.

[0025] Equalization can be achieved to a limited extent by adjusting drive currents from the controller **4500** and front-end **4030** amplification accordingly to wavelength so as to compensate for tissue absorption characteristics. Signal demodulation constraints, however, limit the magnitude of these adjustments. Advantageously, equalization **900** is also provided along the optical path from emitters **500** to detector **2400**. Equalization embodiments are described in further detail with respect to FIGS. **10-11**, below.

[0026] FIGS. **10A-D** illustrate various equalization embodiments having an emitter array **700** adapted to transmit optical radiation into a tissue site **1** and a detector assembly **2400** adapted to generate a sensor signal **2500** responsive to the optical radiation after tissue attenuation. FIG. **10A** illustrates an optical filter **1100** that attenuates at least a portion of the optical radiation before it is transmitted into a tissue site **1**. In particular, the optical filter **1100** attenuates at least a portion of the IR wavelength spectrum of the optical radiation so as to approximate an equalization curve **900** (FIG. **9**). FIG. **10B** illustrates an optical filter **1100** that attenuates at least a portion of the optical radiation after it is attenuated by a tissue site **1**, where the optical filter **1100** approximates an equalization curve **900** (FIG. **9**).

[0027] FIG. **10C** illustrates an emitter array **700** where at least a portion of the emitter array generates one or more wavelengths from multiple light emitters **710** of the same wavelength. In particular, the same-wavelength light emitters **710** boost at least a portion of the red wavelength spectrum so as to approximately equalize the attenuation curves **910** (FIG. **9**). FIG. **10D** illustrates a detector assembly **2400** having multiple detectors **2610**, **2620** selected so as to equalize the attenuation curves **910** (FIG. **9**). To a limited extent, optical equalization can also be achieved by selection of particular emitter array **700** and detector **2400** components, e.g. LEDs having higher output intensities or detectors having higher sensitivities at red wavelengths. Although equalization embodiments are described above with respect to red and IR wavelengths, these equalization embodiments can be applied to equalize tissue characteristics across any portion of the optical spectrum.

[0028] FIGS. **11A-C** illustrates an optical filter **1100** for an emitter assembly **500** that advantageously provides optical equalization, as described above. LEDs within the emitter array **700** may be grouped according to output intensity or wavelength or both. Such a grouping facilitates equalization of LED intensity across the array. In particular, relatively low tissue absorption and/or relatively high output intensity LEDs can be grouped together under a relatively high attenuation optical filter. Likewise, relatively low tissue absorption and/or relatively low output intensity LEDs can be grouped together without an optical filter or under a relatively low or negligible atten-

uation optical filter. Further, high tissue absorption and/or low intensity LEDs can be grouped within the same row with one or more LEDs of the same wavelength being simultaneously activated, as described with respect to FIG. 10C, above. In general, there can be any number of LED groups and any number of LEDs within a group. There can also be any number of optical filters corresponding to the groups having a range of attenuation, including no optical filter and/or a "clear" filter having negligible attenuation.

[0029] As shown in FIGS. 11A-C, a filtering media may be advantageously added to an encapsulant that functions both as a cover to protect LEDs and bonding wires and as an optical filter 1100. In one embodiment, a filtering media 1100 encapsulates a select group of LEDs and a clear media 600 (FIG. 6) encapsulates the entire array 700 and the filtering media 1000 (FIG. 6). In a particular embodiment, corresponding to TABLE 1, above, five LEDs nominally emitting at 660-905 nm are encapsulated with both a filtering media 1100 and an overlying clear media 600 (FIG. 6), i.e. attenuated. In a particular embodiment, the filtering media 1100 is a 40:1 mixture of a clear encapsulant (EPO-TEK OG147-7) and an opaque encapsulate (EPO-TEK OG147) both available from Epoxy Technology, Inc., Billerica, MA. Three LEDs nominally emitting at 610-630 nm are only encapsulated with the clear media 600 (FIG. 6), i.e. unattenuated.

In alternative embodiments, individual LEDs may be singly or multiply encapsulated according to tissue absorption and/or output intensity. In other alternative embodiments, filtering media may be separately attachable optical filters or a combination of encapsulants and separately attachable optical filters. In a particular embodiment, the emitter assembly 500 has one or more notches along each side proximate the component end 1305 (FIG. 13) for retaining one or more clip-on optical filters.

Substrate

[0030] FIG. 12 illustrates light emitters 710 configured to transmit optical radiation 1201 having multiple wavelengths in response to corresponding drive currents 1210. A thermal mass 1220 is disposed proximate the emitters 710 so as to stabilize a bulk temperature 1202 for the emitters. A temperature sensor 1230 is thermally coupled to the thermal mass 1220, wherein the temperature sensor 1230 provides a temperature sensor output 1232 responsive to the bulk temperature 1202 so that the wavelengths are determinable as a function of the drive currents 1210 and the bulk temperature 1202.

[0031] In one embodiment, an operating wavelength λ_a of each light emitter 710 is determined according to EQ. 3

$$\lambda_a = f(T_b, I_{drive}, \sum I_{drive}) \quad (3)$$

where T_b is the bulk temperature, I_{drive} is the drive current for a particular light emitter, as determined by the sensor controller 4500 (FIG. 45), described below, and $\sum I_{drive}$ is the total drive current for all light emitters. In another embodiment, temperature sensors are configured to measure the temperature of each light emitter 710 and an operating wavelength λ_a of each light emitter 710 is determined according to EQ. 4

$$\lambda_a = f(T_a, I_{drive}, \sum I_{drive}) \quad (4)$$

where T_a is the temperature of a particular light emitter, I_{drive} is the drive current for that light emitter and $\sum I_{drive}$ is the total drive current for all light emitters.

[0032] In yet another embodiment, an operating wavelength for each light emitter is determined by measuring the junction voltage for each light emitter 710. In a further embodiment, the temperature of each light emitter 710 is controlled, such as by one or more Peltier cells coupled to each light emitter 710, and an operating wavelength for each light emitter 710 is determined as a function of the resulting controlled temperature or temperatures. In other embodiments, the operating wavelength for each light emitter 710 is determined directly, for example by attaching a charge coupled device (CCD) to each light emitter or by attaching a fiberoptic to each light emitter and coupling the fiberoptics to a wavelength measuring device, to name a few.

[0033] FIGS. 13-18 illustrate one embodiment of a substrate 1200 configured to provide thermal conductivity between an emitter array 700 (FIG. 8) and a thermistor 1540 (FIG. 16). In this manner, the resistance of the thermistor 1540 (FIG. 16) can be measured in order to determine the bulk temperature of LEDs 801 (FIG. 8) mounted on the substrate 1200. The substrate 1200 is also configured with a relatively significant thermal mass, which stabilizes and normalizes the bulk temperature so that the thermistor measurement of bulk temperature is meaningful.

[0034] FIGS. 13-14 illustrate a substrate 1200 having a component side 1301, a solder side 1302, a component end 1305 and a connector end 1306. Alignment notches 1310 are disposed between the ends 1305, 1306. The substrate 1200 further has a component layer 1401, inner layers 1402-1405 and a solder layer 1406. The inner layers 1402-1405, e.g. inner layer 1402 (FIG. 18), have substantial metallized areas 1411 that provide a thermal mass 1220 (FIG. 12) to stabilize a bulk temperature for the emitter array 700 (FIG. 12). The metallized areas 1411 also function to interconnect component pads 1510 and wire bond pads 1520 (FIG. 15) to the connector 1530.

[0035] FIGS. 15-16 illustrate a substrate 1200 having component pads 1510 and wire bond pads 1520 at a component end 1305. The component pads 1510 mount and electrically connect a first side (anode or cathode)

of the LEDs **801** (FIG. **8**) to the substrate **1200**. Wire bond pads **1520** electrically connect a second side (cathode or anode) of the LEDs **801** (FIG. **8**) to the substrate **1200**. The connector end **1306** has a connector **1530** with connector pads **1532**, **1534** that mount and electrically connect the emitter assembly **500** (FIG. **23**), including the substrate **1200**, to the flex circuit **2200** (FIG. **22**). Substrate layers **1401-1406** (FIG. **14**) have traces that electrically connect the component pads **1510** and wire bond pads **1520** to the connector **1532-1534**. A thermistor **1540** is mounted to thermistor pads **1550** at the component end **1305**, which are also electrically connected with traces to the connector **1530**. Plated thru holes electrically connect the connector pads **1532**, **1534** on the component and solder sides **1301**, **1302**, respectively.

[0036] FIG. **17** illustrates the electrical layout of a substrate **1200**. A portion of the LEDs **801**, including D1-D4 and D13-D16 have cathodes physically and electrically connected to component pads **1510** (FIG. **15**) and corresponding anodes wire bonded to wire bond pads **1520**. Another portion of the LEDs **801**, including D5-D8 and D9-D12, have anodes physically and electrically connected to component pads **1510** (FIG. **15**) and corresponding cathodes wire bonded to wire bond pads **1520**. The connector **1530** has row pinouts J21-J24, column pinouts J31-J34 and thermistor pinouts J40-J41 for the LEDs **801** and thermistor **1540**.

Interconnect Assembly

[0037] FIG. **19** illustrates an interconnect assembly **1900** that mounts the emitter assembly **500** and detector assembly **2400**, connects to the sensor cable **4400** and provides electrical communications between the cable and each of the emitter assembly **500** and detector assembly **2400**. In one embodiment, the interconnect assembly **1900** is incorporated with the attachment assembly **2700**, which holds the emitter and detector assemblies to a tissue site. An interconnect assembly embodiment utilizing a flexible (flex) circuit is described with respect to FIGS. **20-24**, below.

[0038] FIG. **20** illustrates an interconnect assembly **1900** embodiment having a circuit substrate **2200**, an emitter mount **2210**, a detector mount **2220** and a cable connector **2230**. The emitter mount **2210**, detector mount **2220** and cable connector **2230** are disposed on the circuit substrate **2200**. The emitter mount **2210** is adapted to mount an emitter assembly **500** having multiple emitters. The detector mount **2220** is adapted to mount a detector assembly **2400** having a detector. The cable connector **2230** is adapted to attach a sensor cable **4400**. A first plurality of conductors **2040** disposed on the circuit substrate **2200** electrically interconnects the emitter mount **2210** and the cable connector **2230**. A second plurality of conductors **2050** disposed on the circuit substrate **2200** electrically interconnects the detector mount **2220** and the cable connector **2230**. A decoupling **2060** disposed proximate the cable connector **2230** substan-

tially mechanically isolates the cable connector **2230** from both the emitter mount **2210** and the detector mount **2220** so that sensor cable stiffness is not translated to the emitter assembly **500** or the detector assembly **2400**.

5 A shield **2070** is adapted to fold over and shield one or more wires or pairs of wires of the sensor cable **4400**.

[0039] FIG. **21** illustrates a flex circuit assembly **1900** having a flex circuit **2200**, an emitter assembly **500** and a detector assembly **2400**, which is configured to terminate the sensor end of a sensor cable **4400**. The flex circuit assembly **1900** advantageously provides a structure that electrically connects yet mechanically isolates the sensor cable **4400**, the emitter assembly **500** and the detector assembly **2400**. As a result, the mechanical stiffness of the sensor cable **4400** is not translated to the sensor pads **3000**, **3100** (FIGS. **30-31**), allowing a comfortable finger attachment for the sensor **200** (FIG. **1**). In particular, the emitter assembly **500** and detector assembly **2400** are mounted to opposite ends **2201**, **2202** (FIG. **22**) of an elongated flex circuit **2200**. The sensor cable **4400** is mounted to a cable connector **2230** extending from a middle portion of the flex circuit **2200**. Detector wires **4470** are shielded at the flex circuit junction by a fold-over conductive ink flap **2240**, which is connected to a cable inner shield **4450**. The flex circuit **2200** is described in further detail with respect to FIG. **22**. The emitter portion of the flex circuit assembly **1900** is described in further detail with respect to FIG. **23**. The detector assembly **2400** is described with respect to FIG. **24**. The sensor cable **4400** is described with respect to FIGS. **44A-B**, below.

[0040] FIG. **22** illustrates a sensor flex circuit **2200** having an emitter end **2201**, a detector end **2202**, an elongated interconnect **2204**, **2206** between the ends **2201**, **2202** and a cable connector **2230** extending from the interconnect **2204**, **2206**. The emitter end **2201** forms a "head" having emitter solder pads **2210** for attaching the emitter assembly **500** (FIG. **6**) and mounting ears **2214** for attaching to the emitter pad **3000** (FIG. **30B**), as described below. The detector end **2202** has detector solder pads for attaching the detector **2410** (FIG. **24**). The interconnect **2204** between the emitter end **2201** and the cable connector **2230** forms a "neck," and the interconnect **2206** between the detector end **2202** and the cable connector **2230** forms a "tail." The cable connector **2230** forms "wings" that extend from the interconnect **2204**, **2206** between the neck **2204** and tail **2206**. A conductive ink flap **2240** connects to the cable inner shield **4450** (FIGS. **44A-B**) and folds over to shield the detector wires **4470** (FIGS. **44A-B**) soldered to the detector wire pads **2236**. The outer wire pads **2238** connect to the remaining cable wires **4430** (FIGS. **44A-B**). The flex circuit **2200** has top coverlay, top ink, inner coverlay, trace, trace base, bottom ink and bottom coverlay layers.

[0041] The flex circuit **2200** advantageously provides a connection between a multiple wire sensor cable **4400** (FIGS. **44A-B**), a multiple wavelength emitter assembly **500** (FIG. **6**) and a detector assembly **2400** (FIG. **24**)

without rendering the emitter and detector assemblies unwieldy and stiff. In particular, the wings **2230** provide a relatively large solder pad area **2232** that is narrowed at the neck **2204** and tail **2206** to mechanically isolate the cable **4400** (FIGS. **44A-B**) from the remainder of the flex circuit **2200**. Further, the neck **2206** is folded (see FIG. **4**) for installation in the emitter pad **3000** (FIGS. **30A-H**) and acts as a flexible spring to further mechanically isolate the cable **4400** (FIGS. **44A-B**) from the emitter assembly **500** (FIG. **4**). The tail **2206** provides an integrated connectivity path between the detector assembly **2400** (FIG. **24**) mounted in the detector pad **3100** (FIGS. **31A-H**) and the cable connector **2230** mounted in the opposite emitter pad **3000** (FIGS. **30A-H**).

[0042] FIG. **23** illustrates the emitter portion of the flex circuit assembly **1900** (FIG. **21**) having the emitter assembly **500**. The emitter assembly connector **1530** is attached to the emitter end **2210** of the flex circuit **2200** (FIG. **22**). In particular, reflow solder **2330** connects through hole pads **1532**, **1534** of the emitter assembly **500** to corresponding emitter pads **2310** of the flex circuit **2200** (FIG. **22**).

[0043] FIG. **24** illustrates a detector assembly **2400** including a detector **2410**, solder pads **2420**, copper mesh tape **2430**, an EMI shield **2440** and foil **2450**. The detector **2410** is soldered **2460** chip side down to detector solder pads **2420** of the flex circuit **2200**. The detector solder joint and detector ground pads **2420** are wrapped with the Kapton tape **2470**. EMI shield tabs **2442** are folded onto the detector pads **2420** and soldered. The EMI shield walls are folded around the detector **2410** and the remaining tabs **2442** are soldered to the back of the EMI shield **2440**. The copper mesh tape **2430** is cut to size and the shielded detector and flex circuit solder joint are wrapped with the copper mesh tape **2430**. The foil **2450** is cut to size with a predetermined aperture **2452**. The foil **2450** is wrapped around shielded detector with the foil side in and the aperture **2452** is aligned with the EMI shield grid **2444**.

Detector Assembly

[0044] FIG. **25** illustrates an alternative detector assembly **2400** embodiment having adjacent detectors. Optical radiation having multiple wavelengths generated by emitters **700** is transmitted into a tissue site **1**. Optical radiation at a first set of wavelengths is detected by a first detector **2510**, such as, for example, a Si detector. Optical radiation at a second set of wavelengths is detected by a second detector **2520**, such as, for example, a GaAs detector.

[0045] FIG. **26** illustrates another alternative detector assembly **2400** embodiment having stacked detectors coaxial along a light path. Optical radiation having multiple wavelengths generated by emitters **700** is transmitted into a tissue site **1**. Optical radiation at a first set of wavelengths is detected by a first detector **2610**. Optical radiation at a second set of wavelengths passes through

the first detector **2610** and is detected by a second detector **2620**. In a particular embodiment, a silicon (Si) detector and a gallium arsenide (GaAs) detector are used. The Si detector is placed on top of the GaAs detector so that light must pass through the Si detector before reaching the GaAs detector. The Si detector can be placed directly on top of the GaAs detector or the Si and GaAs detector can be separated by some other medium, such as a transparent medium or air. In another particular embodiment, a germanium detector is used instead of the GaAs detector. Advantageously, the stacked detector arrangement minimizes error caused by pathlength differences as compared with the adjacent detector embodiment.

Finger Clip

[0046] FIG. **27** illustrates a finger clip embodiment **2700** of a physiological sensor attachment assembly. The finger clip **2700** is configured to removably attach an emitter assembly **500** (FIG. **6**) and detector assembly **2400** (FIG. **24**), interconnected by a flex circuit assembly **1900**, to a fingertip. The finger clip **2700** has an emitter shell **3800**, an emitter pad **3000**, a detector pad **2800** and a detector shell **3900**. The emitter shell **3800** and the detector shell **3900** are rotatably connected and urged together by the spring assembly **3500**. The emitter pad **3000** is fixedly retained by the emitter shell. The emitter assembly **500** (FIG. **6**) is mounted proximate the emitter pad **3000** and adapted to transmit optical radiation having a plurality of wavelengths into fingertip tissue. The detector pad **2800** is fixedly retained by the detector shell **3900**. The detector assembly **2400** is mounted proximate the detector pad **2800** and adapted to receive the optical radiation after attenuation by fingertip tissue.

[0047] FIG. **28** illustrates a detector pad **2800** advantageously configured to position and comfortably maintain a fingertip relative to a detector assembly for accurate sensor measurements. In particular, the detector pad has fingertip positioning features including a guide **2810**, a contour **2820** and a stop **2830**. The guide **2810** is raised from the pad surface **2803** and narrows as the guide **2810** extends from a first end **2801** to a second end **2802** so as to increasingly conform to a fingertip as a fingertip is inserted along the pad surface **2803** from the first end **2801**. The contour **2820** has an indentation defined along the pad surface **2803** generally shaped to conform to a fingertip positioned over a detector aperture **2840** located within the contour **2820**. The stop **2830** is raised from the pad surface **2803** so as to block the end of a finger from inserting beyond the second end **2802**. FIGS. **29A-B** illustrate detector pad embodiments **3100**, **3400** each having a guide **2810**, a contour **2820** and a stop **2830**, described in further detail with respect to FIGS. **31** and **34**, respectively.

[0048] FIGS. **30A-H** illustrate an emitter pad **3000** having emitter pad flaps **3010**, an emitter window **3020**, mounting pins **3030**, an emitter assembly cavity **3040**,

isolation notches **3050**, a flex circuit notch **3070** and a cable notch **3080**. The emitter pad flaps **3010** overlap with detector pad flaps **3110** (FIGS. **31A-H**) to block ambient light. The emitter window **3020** provides an optical path from the emitter array **700** (FIG. **8**) to a tissue site. The mounting pins **3030** accommodate apertures in the flex circuit mounting ears **2214** (FIG. **22**), and the cavity **3040** accommodates the emitter assembly **500** (FIG. **21**). Isolation notches **3050** mechanically decouple the shell attachment **3060** from the remainder of the emitter pad **3000**. The flex circuit notch **3070** accommodates the flex circuit tail **2206** (FIG. **22**) routed to the detector pad **3100** (FIGS. **31A-H**). The cable notch **3080** accommodates the sensor cable **4400** (FIGS. **44A-B**). FIGS. **33A-H** illustrate an alternative slim finger emitter pad **3300** embodiment.

[0049] FIGS. **31A-H** illustrate a detector pad **3100** having detector pad flaps **3110**, a shoe box cavity **3120** and isolation notches **3150**. The detector pad flaps **3110** overlap with emitter pad flaps **3010** (FIGS. **30A-H**), interleaving to block ambient light. The shoe box cavity **3120** accommodates a shoe box **3200** (FIG. **32A-H**) described below. Isolation notches **3150** mechanically decouple the attachment points **3160** from the remainder of the detector pad **3100**. FIGS. **34A-H** illustrate an alternative slim finger detector pad **3400** embodiment.

[0050] FIGS. **32A-H** illustrate a shoe box **3200** that accommodates the detector assembly **2400** (FIG. **24**). A detector window **3210** provides an optical path from a tissue site to the detector **2410** (FIG. **24**). A flex circuit notch **3220** accommodates the flex circuit tail **2206** (FIG. **22**) routed from the emitter pad **3000** (FIGS. **30A-H**). In one embodiment, the shoe box **3200** is colored black or other substantially light absorbing color and the emitter pad **3000** and detector pad **3100** are each colored white or other substantially light reflecting color.

[0051] FIGS. **35-37** illustrate a spring assembly **3500** having a spring **3600** configured to urge together an emitter shell **3800** (FIG. **46**) and a detector shell **3900**. The detector shell is rotatably connected to the emitter shell. The spring is disposed between the shells **3800**, **3900** and adapted to create a pivot point along a finger gripped between the shells that is substantially behind the fingertip. This advantageously allows the shell hinge **3810**, **3910** (FIGS. **38-39**) to expand so as to distribute finger clip force along the inserted finger, comfortably keeping the fingertip in position over the detector without excessive force.

[0052] As shown in FIGS **36A-C**, the spring **3600** has coils **3610**, an emitter shell leg **3620** and a detector shell leg **3630**. The emitter shell leg **3620** presses against the emitter shell **3800** (FIGS. **38A-D**) proximate a grip **3820** (FIGS. **38A-D**). The detector shell legs **3630** extend along the detector shell **3900** (FIGS. **39A-D**) to a spring plate **3700** (FIGS. **37A-D**) attachment point. The coil **3610** is secured by hinge pins **410** (FIG. **46**) and is configured to wind as the finger clip is opened, reducing its diameter and stress accordingly.

[0053] As shown in FIGS. **37A-D** the spring plate **3700** has attachment apertures **3710**, spring leg slots **3720**, and a shelf **3730**. The attachment apertures **3710** accept corresponding shell posts **3930** (FIGS. **39A-D**) so as to secure the spring plate **3700** to the detector shell **3900** (FIG. **39A-D**). Spring legs **3630** (FIG. **36A-C**) are slidably anchored to the detector shell **3900** (FIG. **39A-D**) by the shelf **3730**, advantageously allowing the combination of spring **3600**, shells **3800**, **3900** and hinges **3810**, **3910** to adjust to various finger sizes and shapes.

[0054] FIGS. **38-39** illustrate the emitter and detector shells **3800**, **3900**, respectively, having hinges **3810**, **3910** and grips **3820**, **3920**. Hinge apertures **3812**, **3912** accept hinge pins **410** (FIG. **46**) so as to create a finger clip. The detector shell hinge aperture **3912** is elongated, allowing the hinge to expand to accommodate a finger.

Monitor And Sensor

[0055] FIG. **40** illustrates a monitor **100** and a corresponding sensor assembly **200**, as described generally with respect to FIGS. **1-3**, above. The sensor assembly **200** has a sensor **400** and a sensor cable **4400**. The sensor **400** houses an emitter assembly **500** having emitters responsive to drivers within a sensor controller **4500** so as to transmit optical radiation into a tissue site. The sensor **400** also houses a detector assembly **2400** that provides a sensor signal **2500** responsive to the optical radiation after tissue attenuation. The sensor signal **2500** is filtered, amplified, sampled and digitized by the front-end **4030** and input to a DSP (digital signal processor) **4040**, which also commands the sensor controller **4500**. The sensor cable **4400** electrically communicates drive signals from the sensor controller **4500** to the emitter assembly **500** and a sensor signal **2500** from the detector assembly **2400** to the front-end **4030**. The sensor cable **4400** has a monitor connector **210** that plugs into a monitor sensor port **110**.

[0056] In one embodiment, the monitor **100** also has a reader **4020** capable of obtaining information from an information element (IE) in the sensor assembly **200** and transferring that information to the DSP **4040**, to another processor or component within the monitor **100**, or to an external component or device that is at least temporarily in communication with the monitor **100**. In an alternative embodiment, the reader function is incorporated within the DSP **4040**, utilizing one or more of DSP I/O, ADC, DAC features and corresponding processing routines, as examples.

[0057] In one embodiment, the monitor connector **210** houses the information element **4000**, which may be a memory device or other active or passive electrical component. In a particular embodiment, the information element **4000** is an EPROM, or other programmable memory, or an EEPROM, or other reprogrammable memory, or both. In an alternative embodiment, the information element **4000** is housed within the sensor **400**, or an information element **4000** is housed within both the monitor

connector **4000** and the sensor **400**. In yet another embodiment, the emitter assembly **500** has an information element **4000**, which is read in response to one or more drive signals from the sensor controller **4500**, as described with respect to FIGS. **41-43**, below. In a further embodiment, a memory information element is incorporated into the emitter array **700** (FIG. **8**) and has characterization information relating to the LEDs **801** (FIG. **8**). In one advantageous embodiment, trend data relating to slowly varying parameters, such as perfusion index, HbCO or METHb, to name a few, are stored in an IE memory device, such as EEPROM.

Back-to-Back LEDs

[**0058**] FIGS. **41-43** illustrate alternative sensor embodiments. A sensor controller **4500** configured to activate an emitter array **700** (FIG. **7**) arranged in an electrical grid, is described with respect to FIG. **7**, above. Advantageously, a sensor controller **4500** so configured is also capable of driving a conventional two-wavelength (red and IR) sensor **4100** having back-to-back LEDs **4110**, **4120** or an information element **4300** or both.

[**0059**] FIG. **41A** illustrates a sensor **4100** having an electrical grid **4130** configured to activate light emitting sources by addressing at least one row conductor and at least one column conductor. A first LED **4110** and a second LED **4120** are configured in a back-to-back arrangement so that a first contact **4152** is connected to a first LED **4110** cathode and a second LED **4120** anode and a second contact **4154** is connected to a first LED **4110** anode and a second LED **4120** cathode. The first contact **4152** is in communications with a first row conductor **4132** and a first column conductor **4134**. The second contact is in communications with a second row conductor **4136** and a second column conductor **4138**. The first LED **4110** is activated by addressing the first row conductor **4132** and the second column conductor **4138**. The second LED **4120** is activated by addressing the second row conductor **4136** and the first column conductor **4134**.

[**0060**] FIG. **41B** illustrates a sensor cable **4400** embodiment capable of communicating signals between a monitor **100** and a sensor **4100**. The cable **4400** has a first row input **4132**, a first column input **4134**, a second row input **4136** and a second column input **4138**. A first output **4152** combines the first row input **4132** and the first column input **4134**. A second output **4154** combines a second row input **4136** and second column input **4138**.

[**0061**] FIG. **41C** illustrates a monitor **100** capable of communicating drive signals to a sensor **4100**. The monitor **4400** has a first row signal **4132**, a first column signal **4134**, a second row signal **4136** and a second column signal **4138**. A first output signal **4152** combines the first row signal **4132** and the first column signal **4134**. A second output signal **4154** combines a second row signal **4136** and second column signal **4138**.

Information Elements

[**0062**] FIGS. **42-43** illustrate information element **4200-4300** embodiments in communications with emitter array drivers configured to activate light emitters connected in an electrical grid. The information elements are configured to provide information as DC values, AC values or a combination of DC and AC values in response corresponding DC, AC or combination DC and AC electrical grid drive signals. FIG. **42** illustrates information element embodiment **4200** advantageously driven directly by an electrical grid having rows **710** and columns **720**. In particular, the information element **4200** has a series connected resistor R_2 **4210** and diode **4220** connected between a row line **710** and a column line **720** of an electrical grid. In this manner, the resistor R_2 value can be read in a similar manner that LEDs **810** (FIG. **8**) are activated. The diode **4220** is oriented, e.g. anode to row and cathode to column as the LEDs so as to prevent parasitic currents from unwanted activation of LEDs **810** (FIG. **8**).

[**0063**] FIGS. **43A-C** illustrate other embodiments where the value of R_1 is read with a DC grid drive current and a corresponding grid output voltage level. In other particular embodiments, the combined values of R_1 , R_2 and C or, alternatively, R_1 , R_2 and L are read with a varying (AC) grid drive currents and a corresponding grid output voltage waveform. As one example, a step in grid drive current is used to determine component values from the time constant of a corresponding rise in grid voltage. As another example, a sinusoidal grid drive current is used to determine component values from the magnitude or phase or both of a corresponding sinusoidal grid voltage. The component values determined by DC or AC electrical grid drive currents can represent sensor types, authorized suppliers or manufacturers, emitter wavelengths among others. Further, a diode D (FIG. **43C**) can be used to provide one information element reading R_1 at one drive level or polarity and another information element reading, combining R_1 and R_2 , at a second drive level or polarity, i.e. when the diode is forward biased.

[**0064**] Passive information element **4300** embodiments may include any of various combinations of resistors, capacitors or inductors connected in series and parallel, for example. Other information element **4300** embodiments connected to an electrical grid and read utilizing emitter array drivers incorporate other passive components, active components or memory components, alone or in combination, including transistor networks, PROMs, ROMs, EPROMs, EEPROMs, gate arrays and PLAs to name a few.

Sensor Cable

[**0065**] FIGS. **44A-B** illustrate a sensor cable **4400** having an outer jacket **4410**, an outer shield **4420**, multiple outer wires **4430**, an inner jacket **4440**, an inner shield **4450**, a conductive polymer **4460** and an inner twisted

wire pair **4470**. The outer wires **4430** are advantageously configured to compactly carry multiple drive signals to the emitter array **700** (FIG. 7). In one embodiment, there are twelve outer wires **4430** corresponding to four anode drive signals **4501** (FIG. 45), four cathode drive signals **4502** (FIG. 45), two thermistor pinouts **1450** (FIG. 15) and two spares. The inner twisted wire pair **4470** corresponds to the sensor signal **2500** (FIG. 25) and is extruded within the conductive polymer **4460** so as to reduce triboelectric noise. The shields **4420**, **4450** and the twisted pair **4470** boost EMI and crosstalk immunity for the sensor signal **2500** (FIG. 25).

Controller

[0066] FIG. 45 illustrates a sensor controller **4500** located in the monitor **100** (FIG. 1) and configured to provide anode drive signals **4501** and cathode drive signals **4502** to the emitter array **700** (FIG. 7). The DSP (digital signal processor) **4040**, which performs signal processing functions for the monitor, also provides commands **4042** to the sensor controller **4500**. These commands determine drive signal **4501**, **4502** levels and timing. The sensor controller **4500** has a command register **4510**, an anode selector **4520**, anode drivers **4530**, current DACs (digital-to-analog converters) **4540**, a current multiplexer **4550**, cathode drivers **4560**, a current meter **4570** and a current limiter **4580**. The command register **4510** provides control signals responsive to the DSP commands **4042**. In one embodiment, the command register **4510** is a shift register that loads serial command data **4042** from the DSP **4040** and synchronously sets output bits that select or enable various functions within the sensor controller **4500**, as described below.

[0067] As shown in FIG. 45, the anode selector **4520** is responsive to anode select **4516** inputs from the command register **4510** that determine which emitter array row **810** (FIG. 8) is active. Accordingly, the anode selector **4520** sets one of the anode on **4522** outputs to the anode drivers **4530**, which pulls up to Vcc one of the anode outputs **4501** to the emitter array **700** (FIG. 8).

[0068] Also shown in FIG. 45, the current DACs **4540** are responsive to command register data **4519** that determines the currents through each emitter array column **820** (FIG. 8). In one embodiment, there are four, 12-bit DACs associated with each emitter array column **820** (FIG. 8), sixteen DACs in total. That is, there are four DAC outputs **4542** associated with each emitter array column **820** (FIG. 8) corresponding to the currents associated with each row **810** (FIG. 8) along that column **820** (FIG. 8). In a particular embodiment, all sixteen DACs **4540** are organized as a single shift register, and the command register **4510** serially clocks DAC data **4519** into the DACs **4540**. A current multiplexer **4550** is responsive to cathode on **4518** inputs from the command register **4510** and anode on **4522** inputs from the anode selector **4520** so as to convert the appropriate DAC outputs **4542** to current set **4552** inputs to the cathode driv-

ers **4560**. The cathode drivers **4560** are responsive to the current set **4552** inputs to pull down to ground one to four of the cathode outputs **4502** to the emitter array **700** (FIG. 8).

5 [0069] The current meter **4570** outputs a current measure **4572** that indicates the total LED current driving the emitter array **700** (FIG. 8). The current limiter **4580** is responsive to the current measure **4572** and limits specified by the command register **4510** so as to prevent excessive power dissipation by the emitter array **700** (FIG. 8). The current limiter **4580** provides an enable **4582** output to the anode selector **4520**. A Hi Limit **4512** input specifies the higher of two preset current limits. The current limiter **4580** latches the enable **4582** output in an off condition when the current limit is exceeded, disabling the anode selector **4520**. A trip reset **4514** input resets the enable **4582** output to re-enable the anode selector **4520**.

20 Sensor Assembly

[0070] As shown in FIG. 46, the sensor **400** has an emitter shell **3800**, an emitter pad **3000**, a flex circuit assembly **2200**, a detector pad **3100** and a detector shell **3900**. A sensor cable **4400** attaches to the flex circuit assembly **2200**, which includes a flex circuit **2100**, an emitter assembly **500** and a detector assembly **2400**. The portion of the flex circuit assembly **2200** having the sensor cable **4400** attachment and emitter assembly **500** is housed by the emitter shell **3800** and emitter pad **3000**. The portion of the flex circuit assembly **2200** having the detector assembly **2400** is housed by the detector shell **3900** and detector pad **3100**. In particular, the detector assembly **2400** inserts into a shoe **3200**, and the shoe **3200** inserts into the detector pad **3100**. The emitter shell **3800** and detector shell **3900** are fastened by and rotate about hinge pins **410**, which insert through coils of a spring **3600**. The spring **3600** is held to the detector shell **3900** with a spring plate **3700**. A finger stop **450** attaches to the detector shell. In one embodiment, a silicon adhesive **420** is used to attach the pads **3000**, **3100** to the shells **3800**, **3900**, a silicon potting compound **430** is used to secure the emitter and detector assemblies **500**, **2400** within the pads **3000**, **3100**, and a cyanoacrylic adhesive **440** secures the sensor cable **4400** to the emitter shell **3800**.

[0071] A multiple wavelength sensor has been disclosed in detail in connection with various embodiments. These embodiments are disclosed by way of examples only and are not to limit the scope of the claims that follow. One of ordinary skill in art will appreciate many variations and modifications.

55 Claims

1. A noninvasive physiological sensor adapted for use in an oximetry system including a monitor and a cable

communicating with said sensor, said sensor comprising:

an electrical grid configured to activate a plurality of light emitting sources (LE710) by addressing at least one of a plurality of row conductors (720) and at least one of a plurality of column conductors (740),
 a first LED (710) and a second LED (710) configured in a back-to-back arrangement so that a first contact is connected to a first LED cathode and a second LED anode and a second contact is connected to a first LED anode and a second LED cathode,
 wherein the first contact is in communications with a first one of the row conductors (720) and a first one of the column conductors (740),
 wherein the second contact is in communications with a second one of the row conductors (720) and a second one of the column conductors (740),
 wherein the first LED is activated by addressing the first row conductor and the second column conductor, and
 wherein the second LED is activated by addressing the second row conductor and the first column conductor.

2. The physiological sensor according to claim 1 further comprising an information element disposed between the first contact and the second contact.
3. The physiological sensor according to claim 2 wherein the information element is adapted to provide information in response to a DC electrical grid drive.
4. The physiological sensor according to claim 2 wherein the information element is adapted to provide information in response to an AC electrical grid drive.
5. The physiological sensor according to claim 2 wherein the information element is adapted to provide information in response to a combination of an AC electrical grid drive and a DC electrical grid drive.
6. The physiological sensor according to claim 2 wherein the information element comprises a passive information element.
7. The physiological sensor according to claim 2 wherein the information element comprises an active information element.
8. The physiological sensor according to claim 2 wherein the information element comprises a memory information element.

Patentansprüche

1. Nichtinvasiver physiologischer Sensor, der zur Verwendung in einem Oxymetriesystem mit einem Monitor und einem mit dem Sensor kommunizierenden Kabel geeignet ist, wobei der Sensor aufweist:
 ein elektrisches Netz, das so konfiguriert ist, dass es mehrere Licht emittierende Quellen (LE, 710) durch Adressieren mindestens eines von mehreren Reihenleitern (720) und mindestens eines von mehreren Spaltenleitern (740) aktiviert,
 eine erste LED (710) und eine zweite LED (710), die in einer Rücken-an-Rücken-Anordnung konfiguriert sind, so dass ein erster Kontakt mit einer ersten LED-Kathode und einer zweiten LED-Anode verbunden ist und ein zweiter Kontakt mit einer ersten LED-Anode und einer zweiten LED-Kathode verbunden ist,
 wobei der erste Kontakt mit einem ersten der Reihenleiter (720) und einem ersten der Spaltenleiter (740) kommuniziert,
 wobei der zweite Kontakt mit einem zweiten der Reihenleiter (720) und einem zweiten der Spaltenleiter (740) kommuniziert,
 wobei die erste LED durch Adressieren des ersten Reihenleiters und des zweiten Spaltenleiters aktiviert wird und
 wobei die zweite LED durch Adressieren des zweiten Reihenleiters und des ersten Spaltenleiters aktiviert wird.
2. Physiologischer Sensor nach Anspruch 1, ferner mit einem Informationselement, das zwischen dem ersten Kontakt und dem zweiten Kontakt angeordnet ist.
3. Physiologischer Sensor nach Anspruch 2, wobei das Informationselement geeignet ist, Informationen als Reaktion auf eine Netzansteuerung mit Gleichstrom bereitzustellen.
4. Physiologischer Sensor nach Anspruch 2, wobei das Informationselement geeignet ist, Informationen als Reaktion auf eine Netzansteuerung mit Wechselstrom bereitzustellen.
5. Physiologischer Sensor nach Anspruch 2, wobei das Informationselement geeignet ist, Informationen als Reaktion auf eine Kombination aus einer Netzansteuerung mit Wechselstrom und einer Netzansteuerung mit Gleichstrom bereitzustellen.
6. Physiologischer Sensor nach Anspruch 2, wobei das Informationselement ein passives Informationselement aufweist.
7. Physiologischer Sensor nach Anspruch 2, wobei das

Informationselement ein aktives Informationselement aufweist.

8. Physiologischer Sensor nach Anspruch 2, wobei das Informationselement ein Speicherinformationselement aufweist.

Revendications

1. Capteur physiologique non invasif adapté pour une utilisation dans un système d'oxymétrie incluant un moniteur et un câble communiquant avec ledit capteur, ledit capteur comprenant :

un réseau électrique configuré pour activer une pluralité de sources électroluminescentes (LE 710) par l'adressage d'au moins l'un d'une pluralité de conducteurs de rangée (720) et au moins l'un d'une pluralité de conducteurs de colonne (740),

une première LED (710) et une seconde LED (710) configurées dans un agencement dos-à-dos de sorte qu'un premier contact est connecté à une première cathode de LED et une seconde anode de LED et un second contact est connecté à une première anode de LED et une seconde cathode de LED,

dans lequel le premier contact est en communication avec un premier des conducteurs de rangée (720) et un premier des conducteurs de colonne (740),

dans lequel le second contact est en communication avec un second des conducteurs de rangée (720) et un second des conducteurs de colonne (740),

dans lequel la première LED est activée par adressage du premier conducteur de rangée et du second conducteur de colonne, et

dans lequel la seconde LED est activée par adressage du second conducteur de rangée et du premier conducteur de colonne.

2. Capteur physiologique selon la revendication 1, comprenant en outre un élément d'information disposé entre le premier contact et le second contact.

3. Capteur physiologique selon la revendication 2, dans lequel l'élément d'information est adapté pour fournir une information en réponse à un pilote de réseau électrique CC.

4. Capteur physiologique selon la revendication 2, dans lequel l'élément d'information est adapté pour fournir des informations en réponse à un pilote de réseau électrique CA.

5. Capteur physiologique selon la revendication 2,

dans lequel l'élément d'information est adapté pour fournir des informations en réponse à une combinaison de pilote de réseau électrique CA et un pilote de réseau électrique CC.

6. Capteur physiologique selon la revendication 2, dans lequel l'élément d'information comprend un élément d'information passif.

7. Capteur physiologique selon la revendication 2, dans lequel l'élément d'information comprend un élément d'information actif.

8. Capteur physiologique selon la revendication 2, dans lequel l'élément d'information comprend un élément d'information à mémoire.

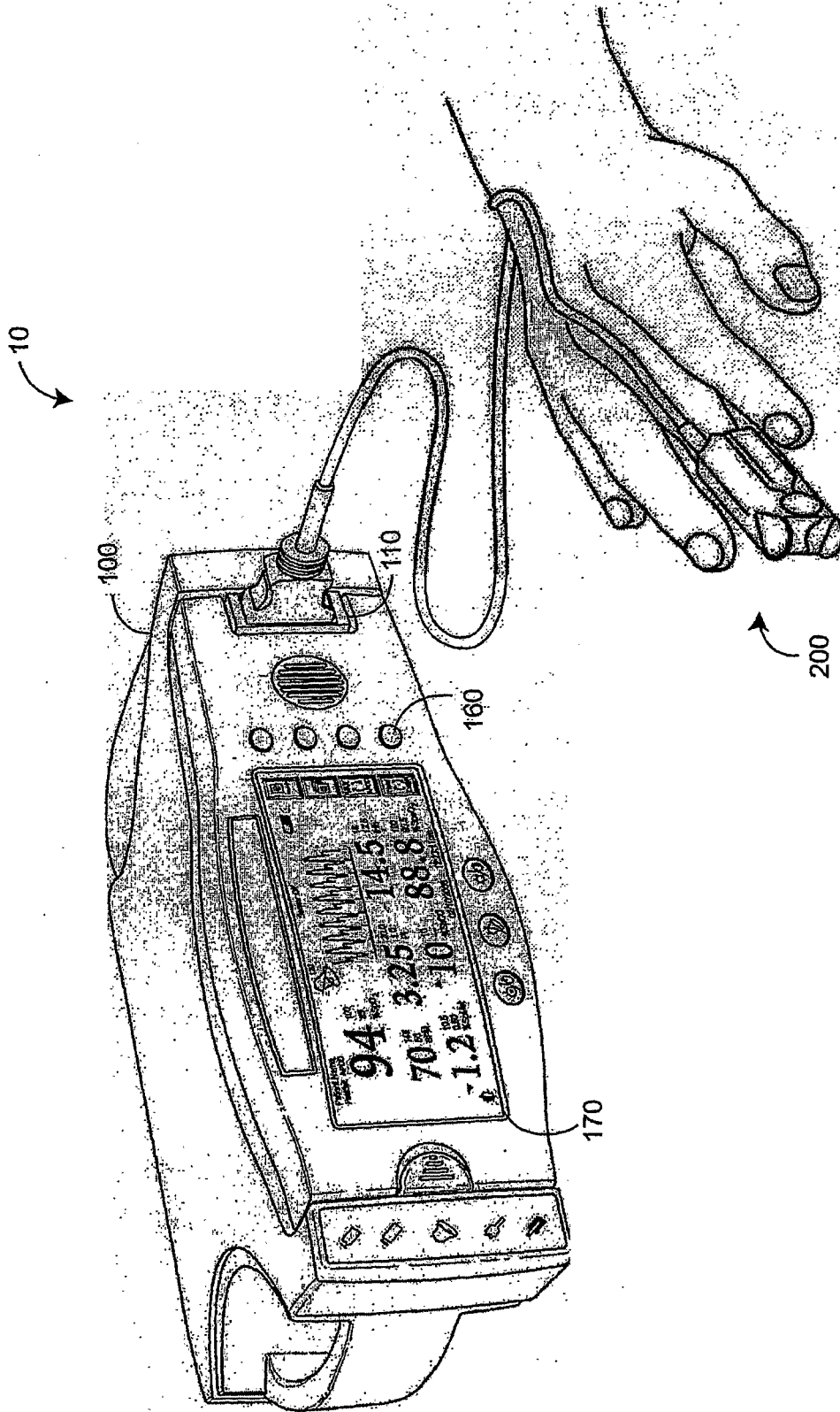

FIG. 1

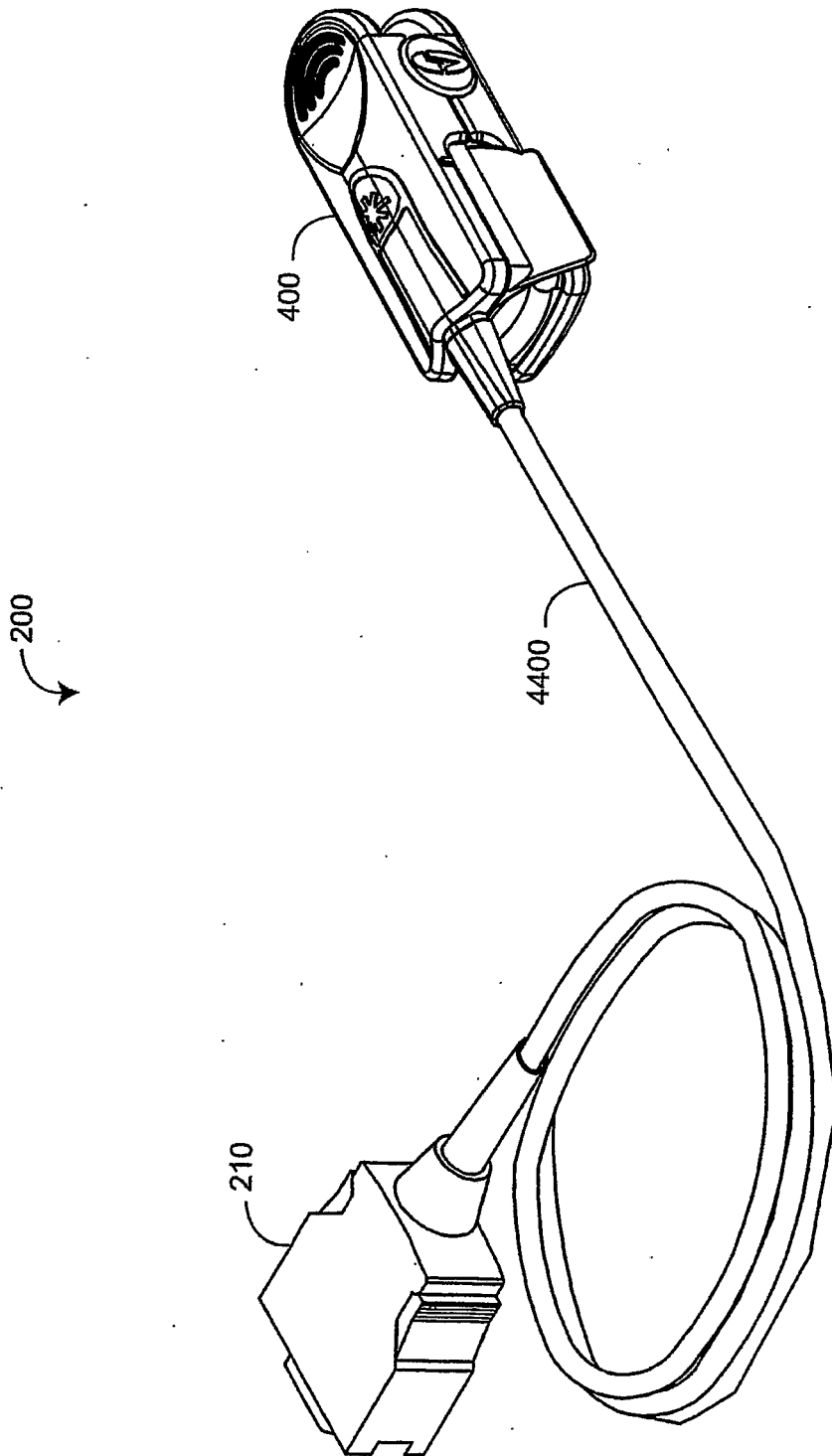

FIG. 2A

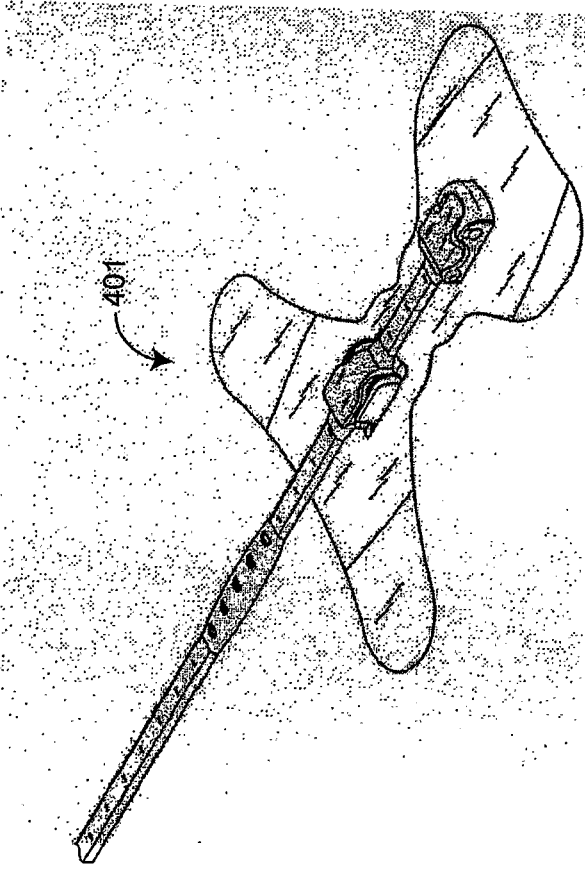

FIG. 2B

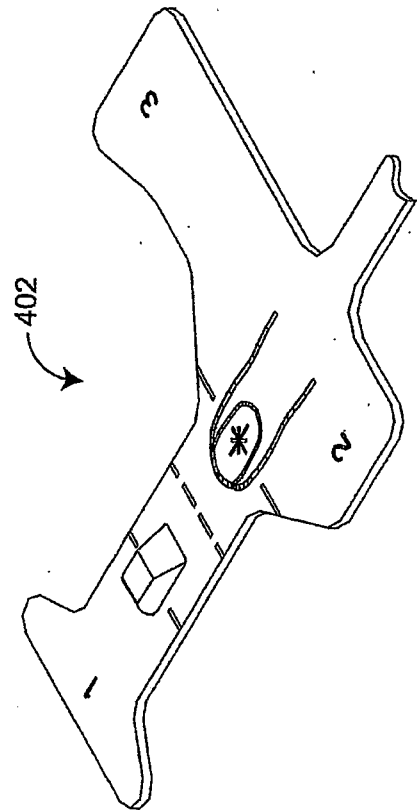

FIG. 2C

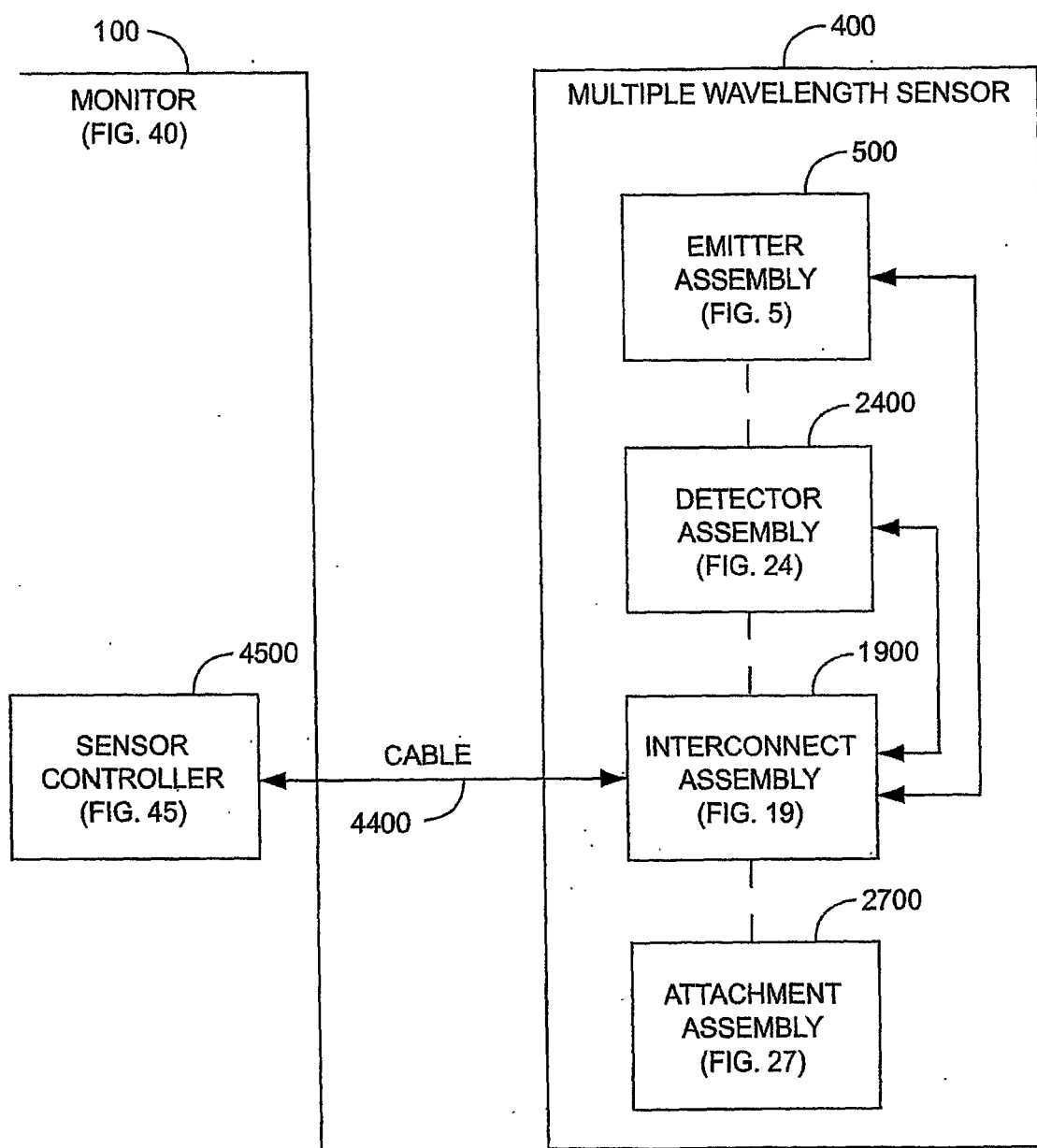

FIG. 3

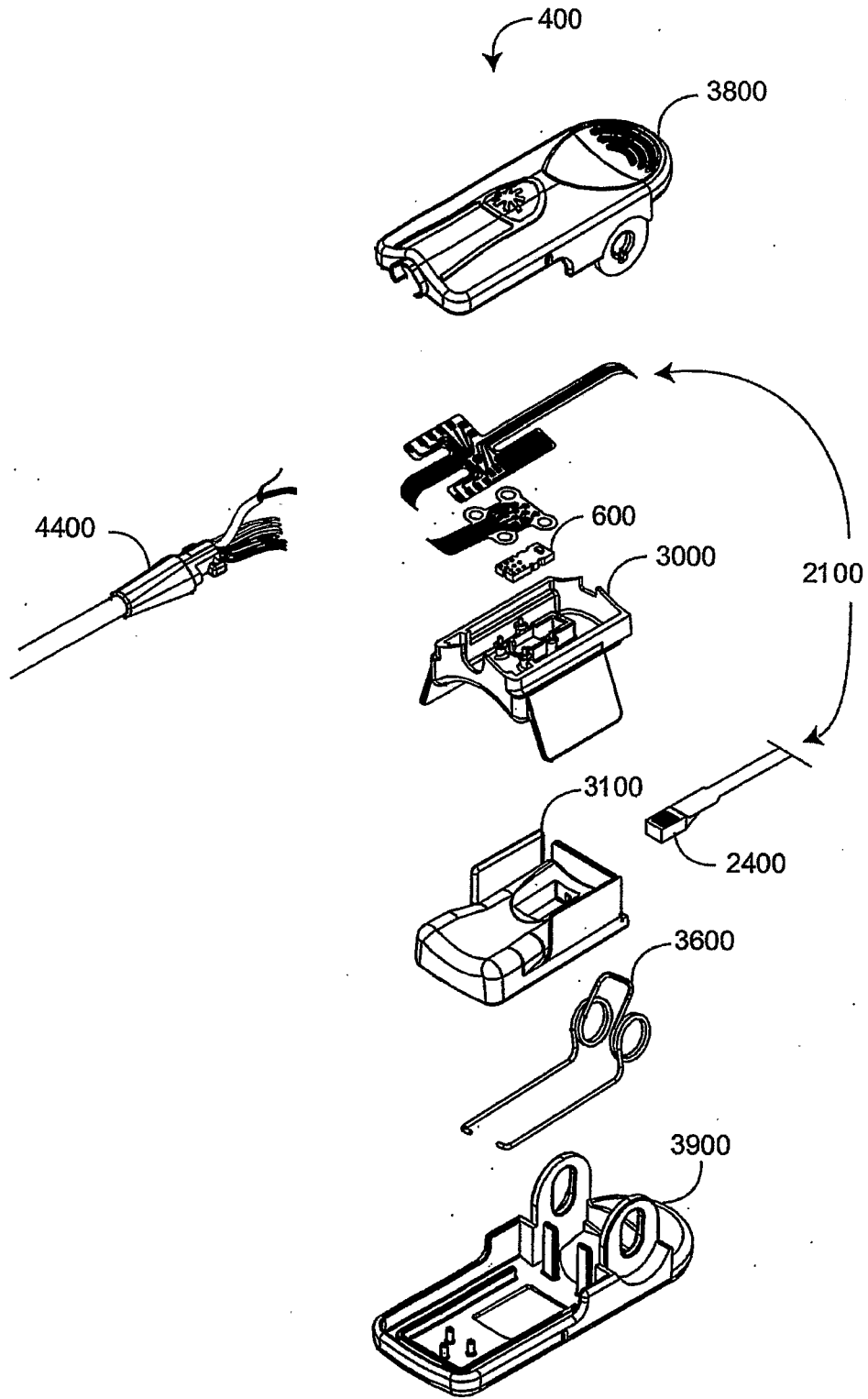

FIG. 4

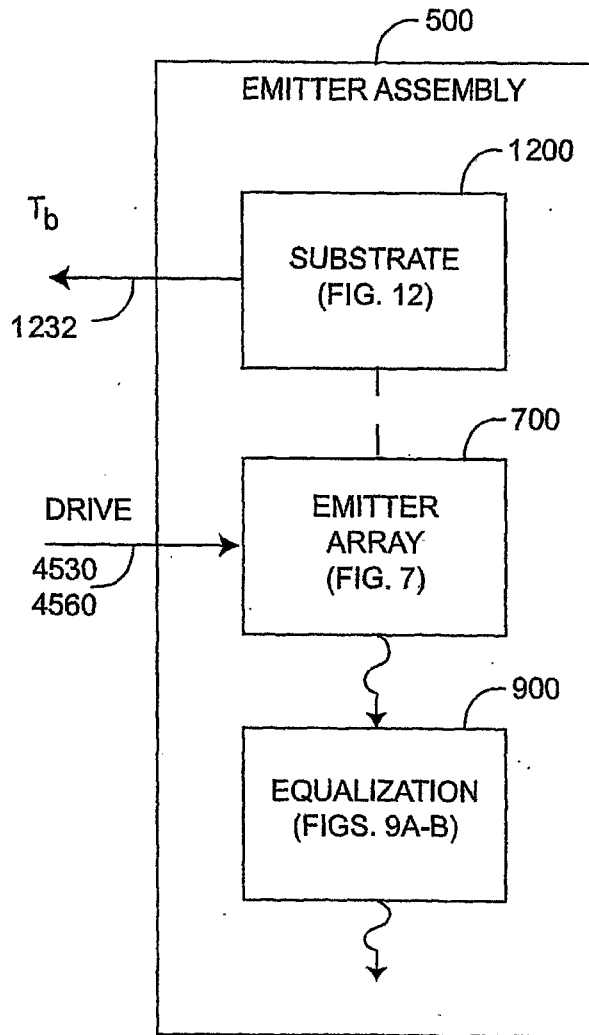

FIG. 5

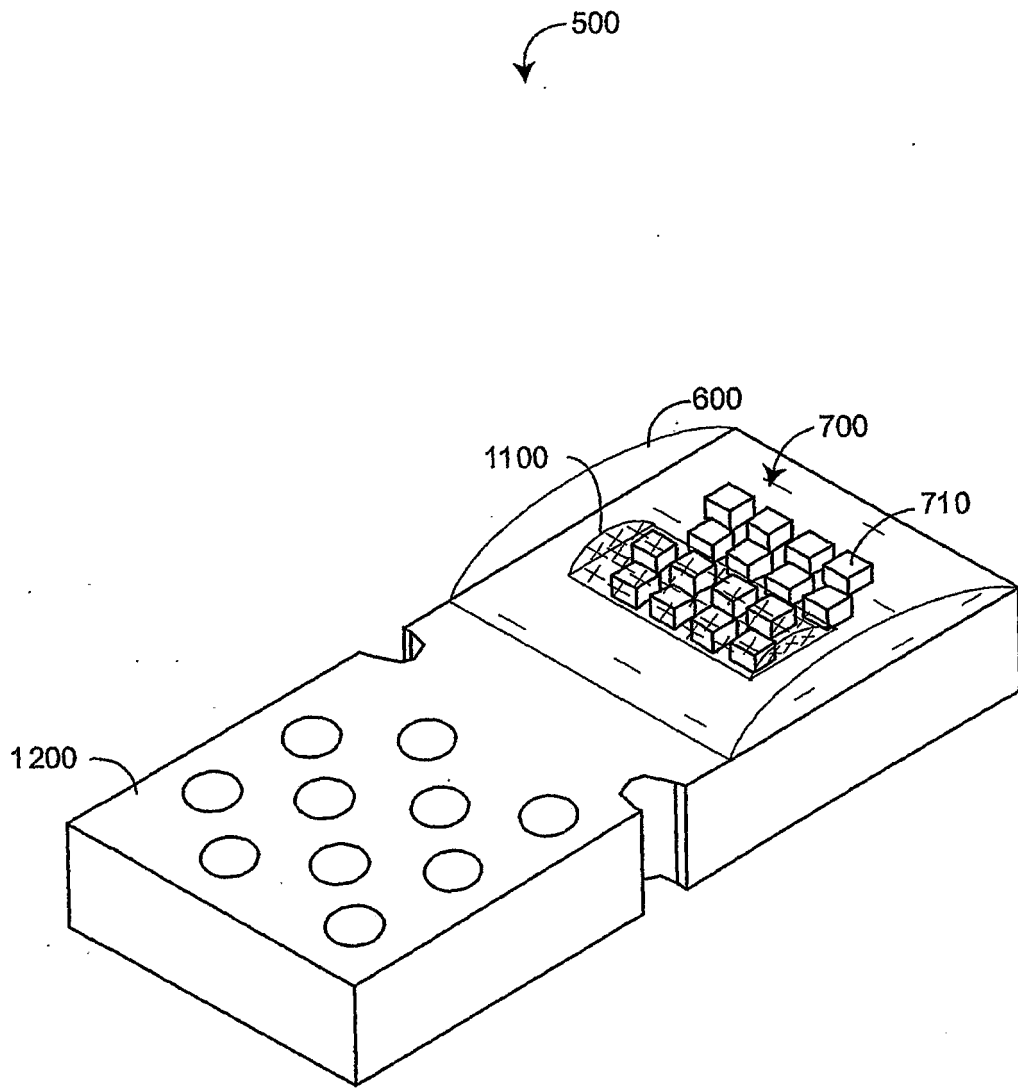

FIG. 6

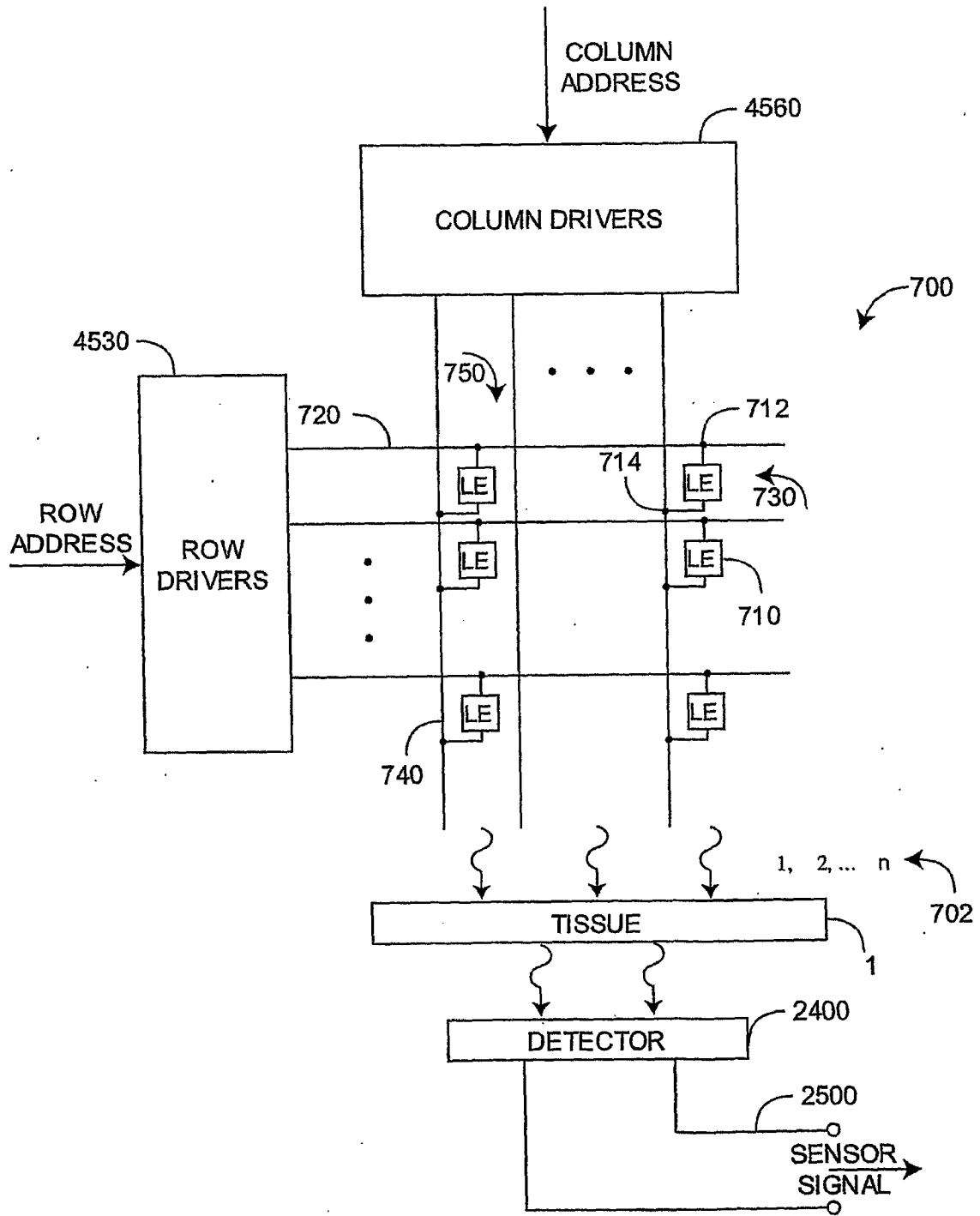

FIG. 7

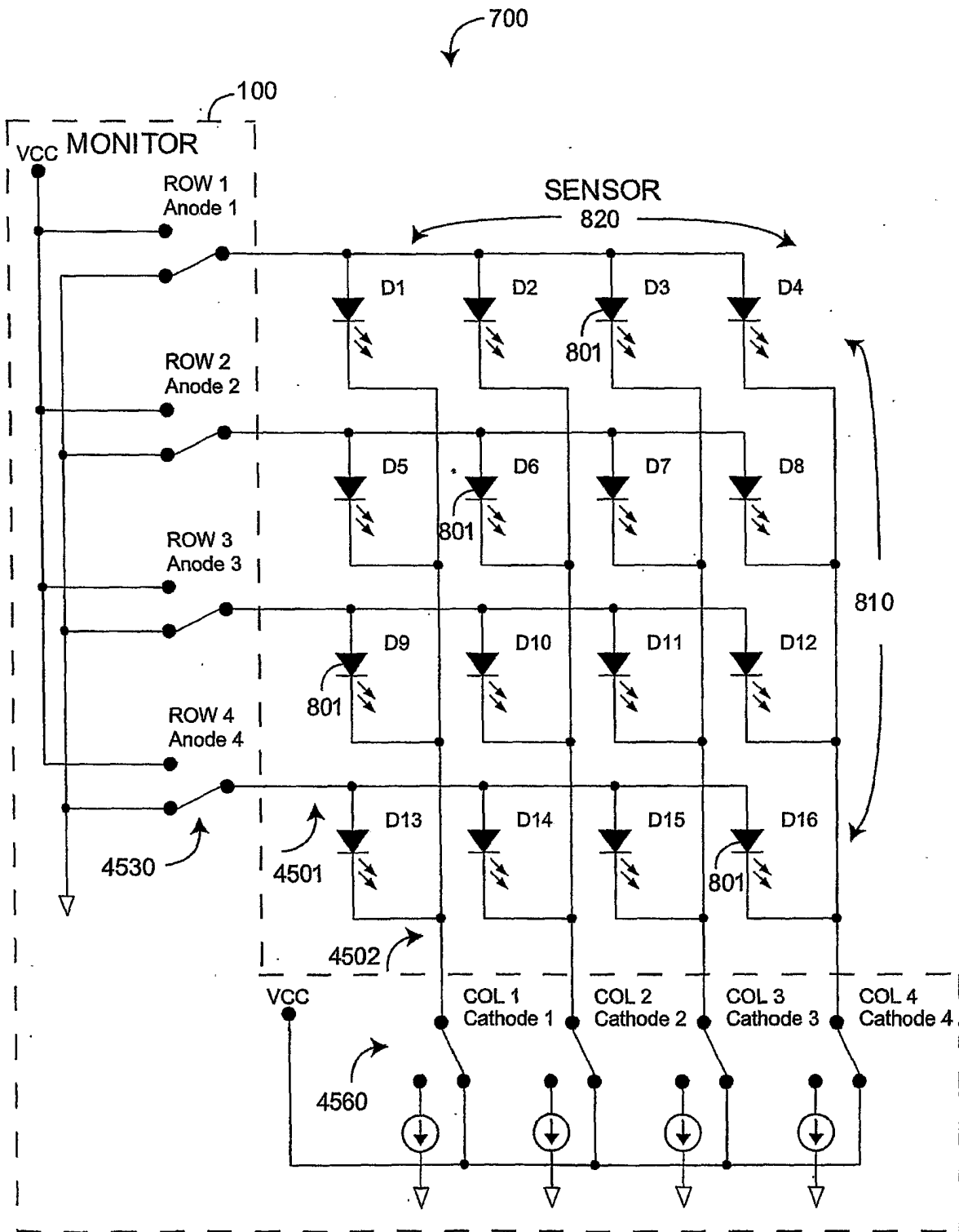

FIG. 8

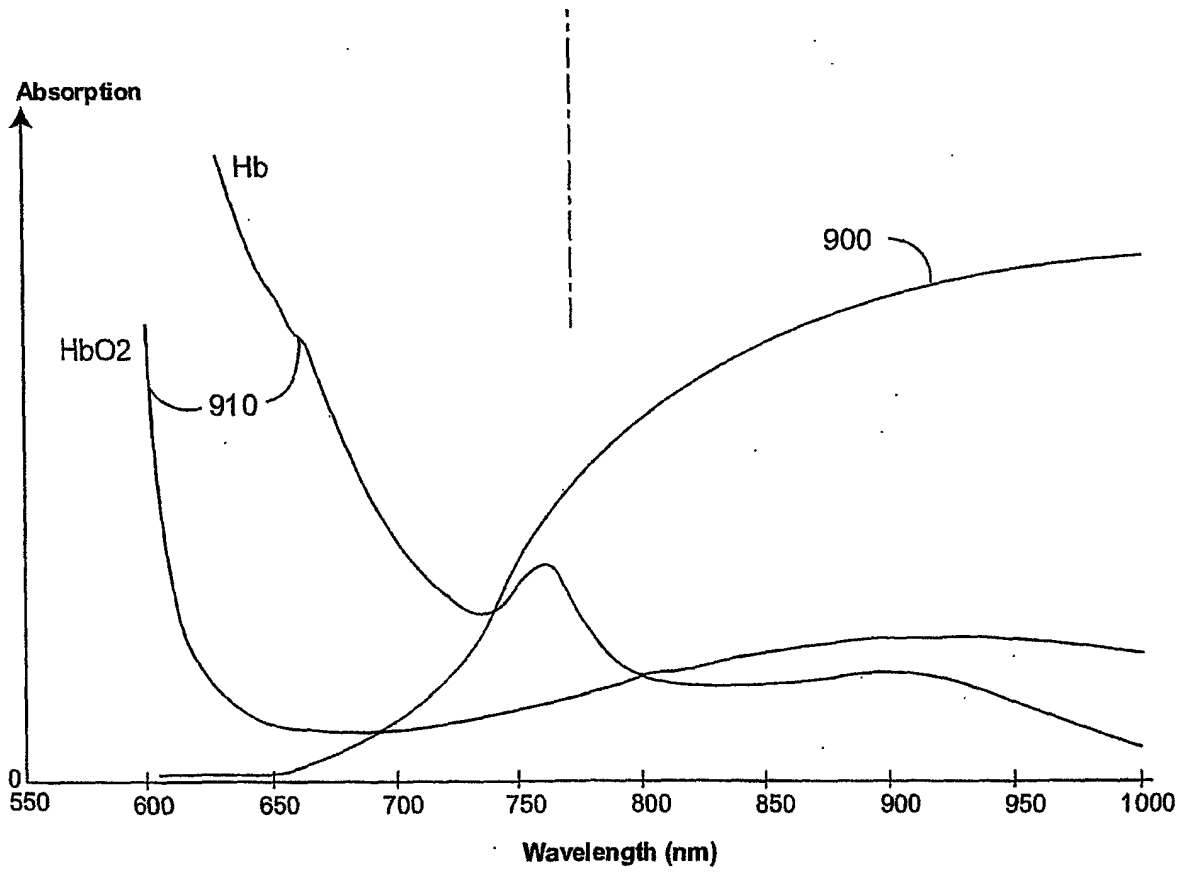
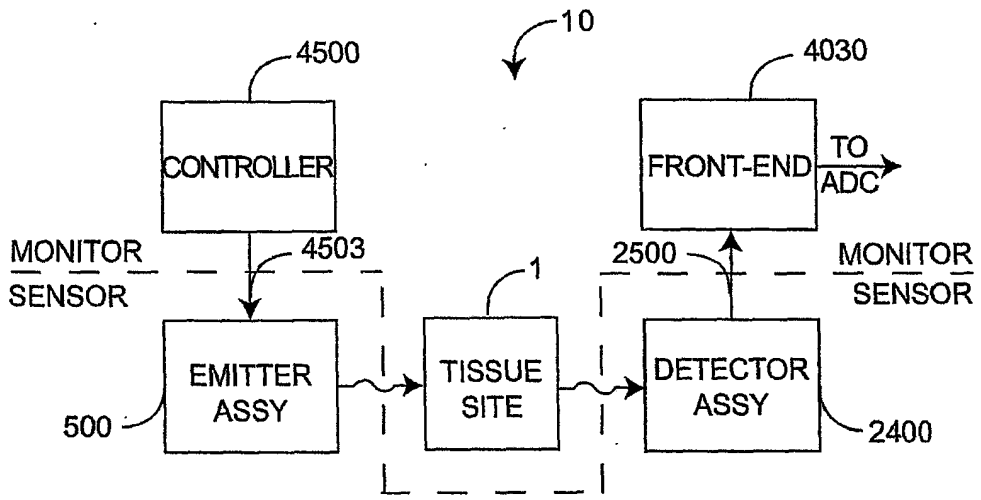

FIG. 9

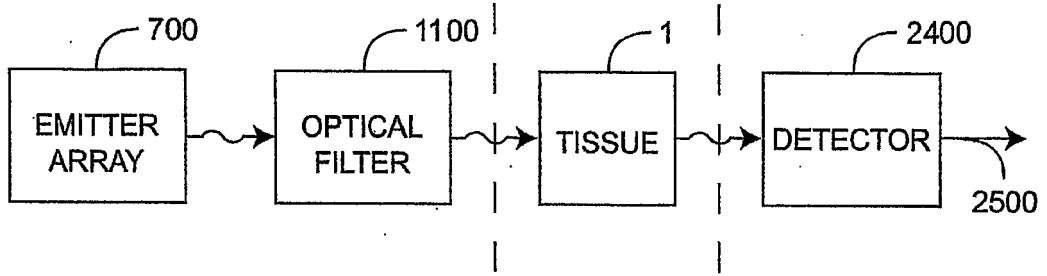

FIG. 10A

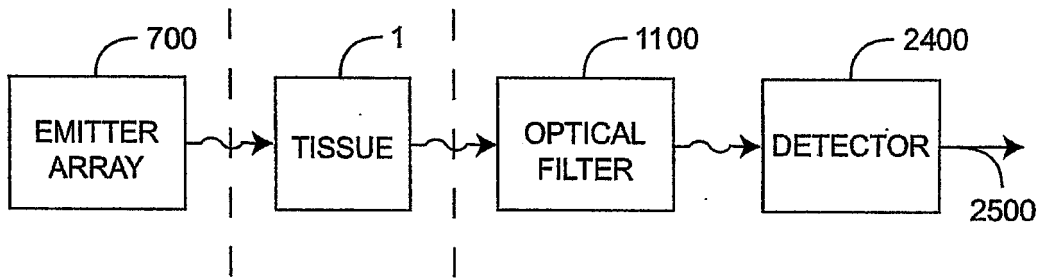

FIG. 10B

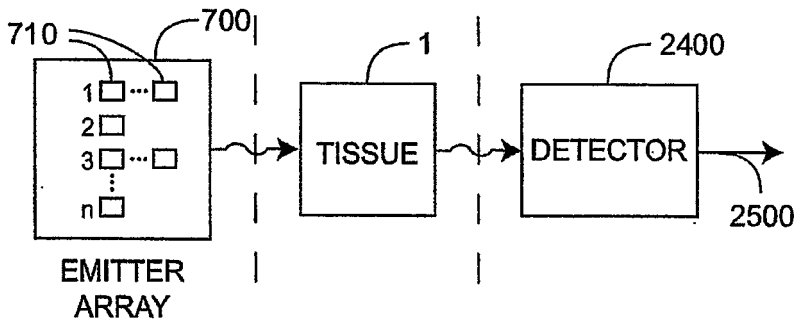

FIG. 10C

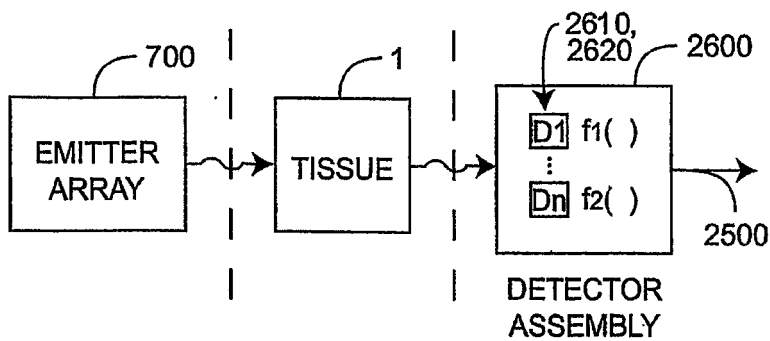

FIG. 10D

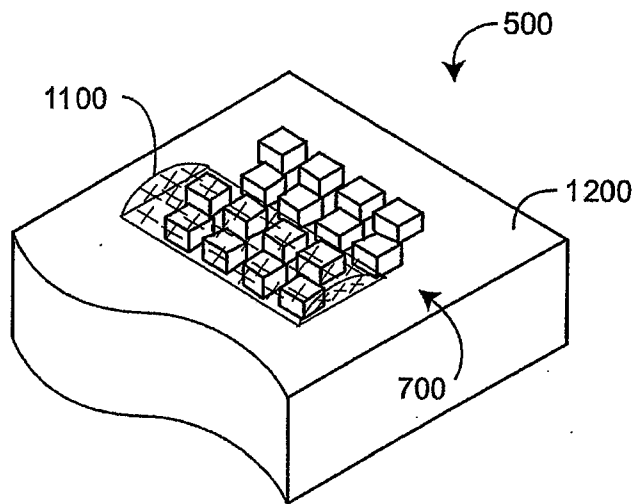

FIG. 11A

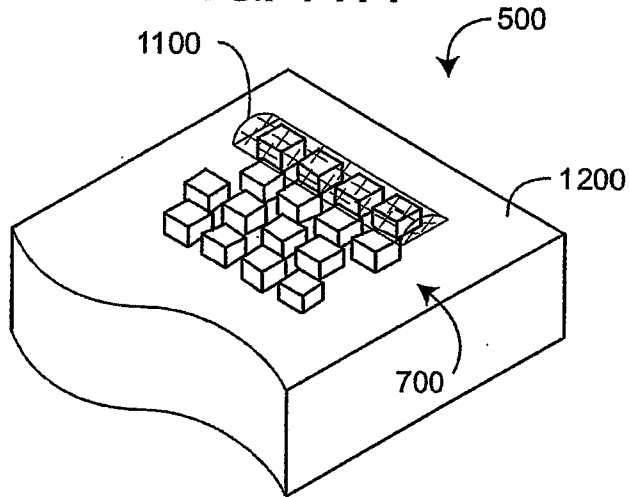

FIG. 11B

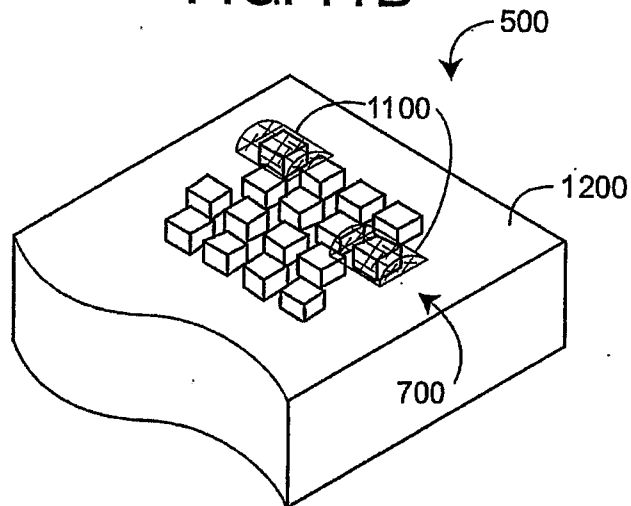

FIG. 11C

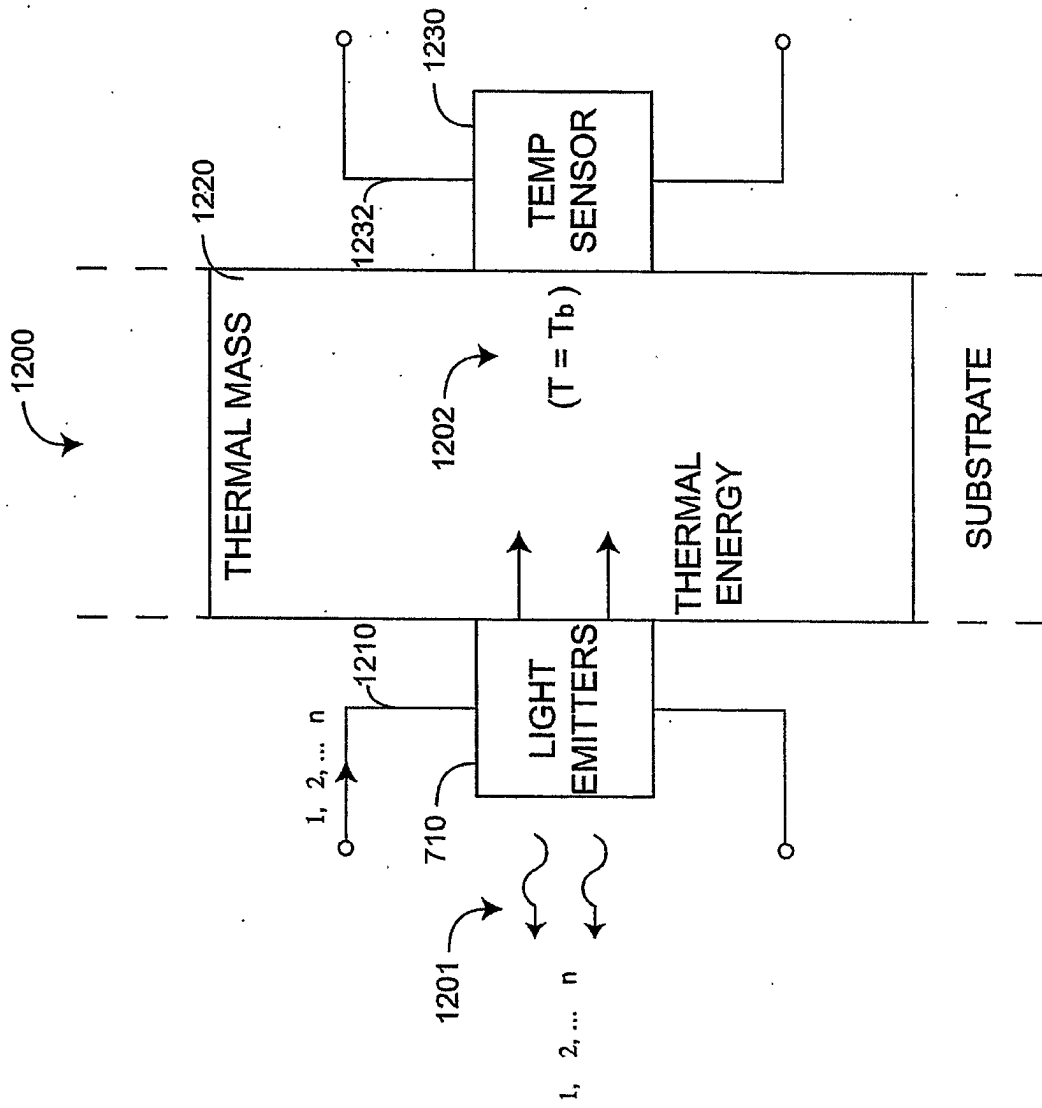
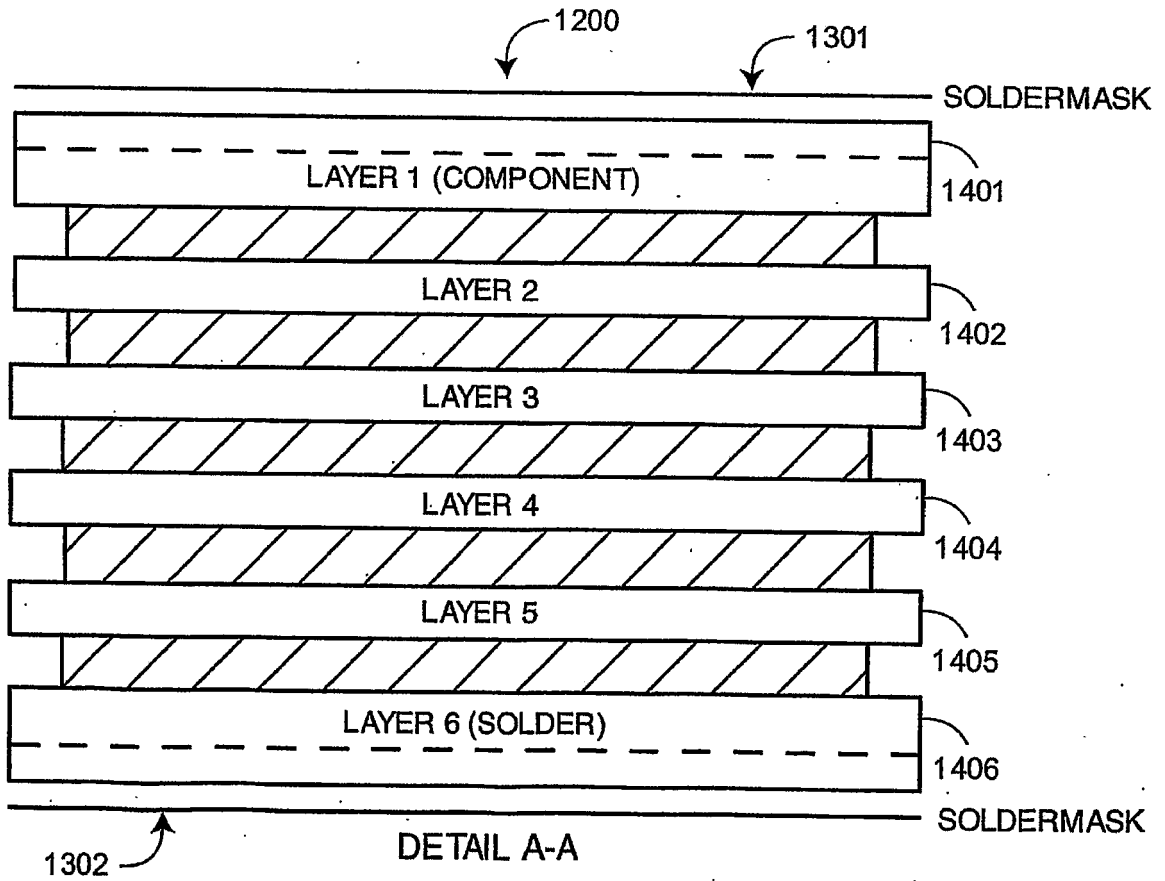
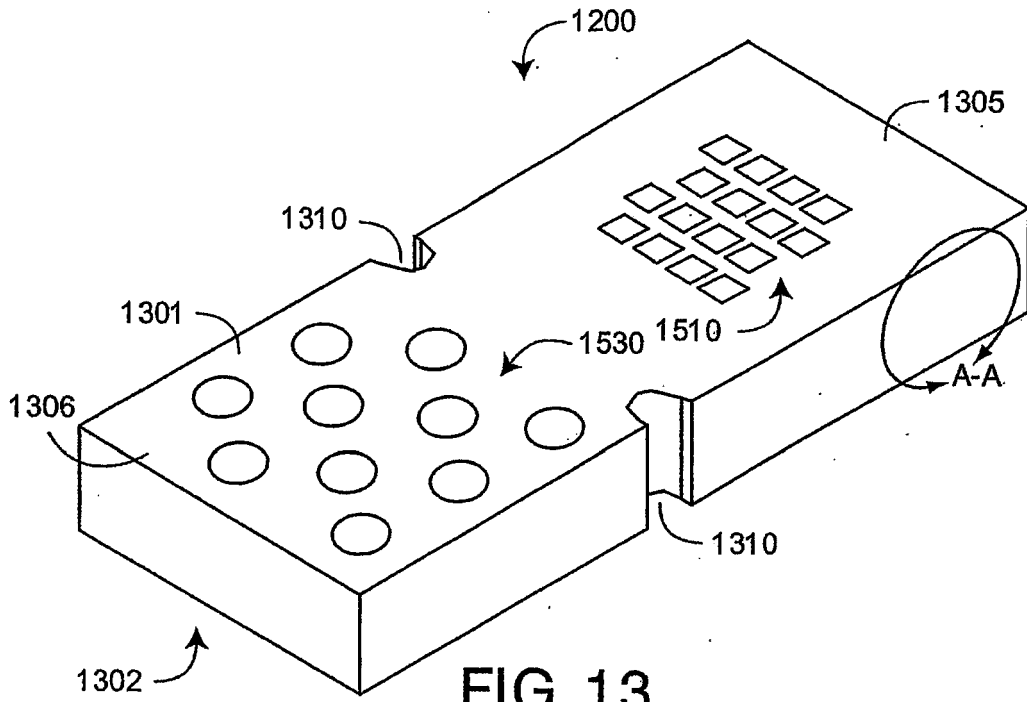

FIG. 12



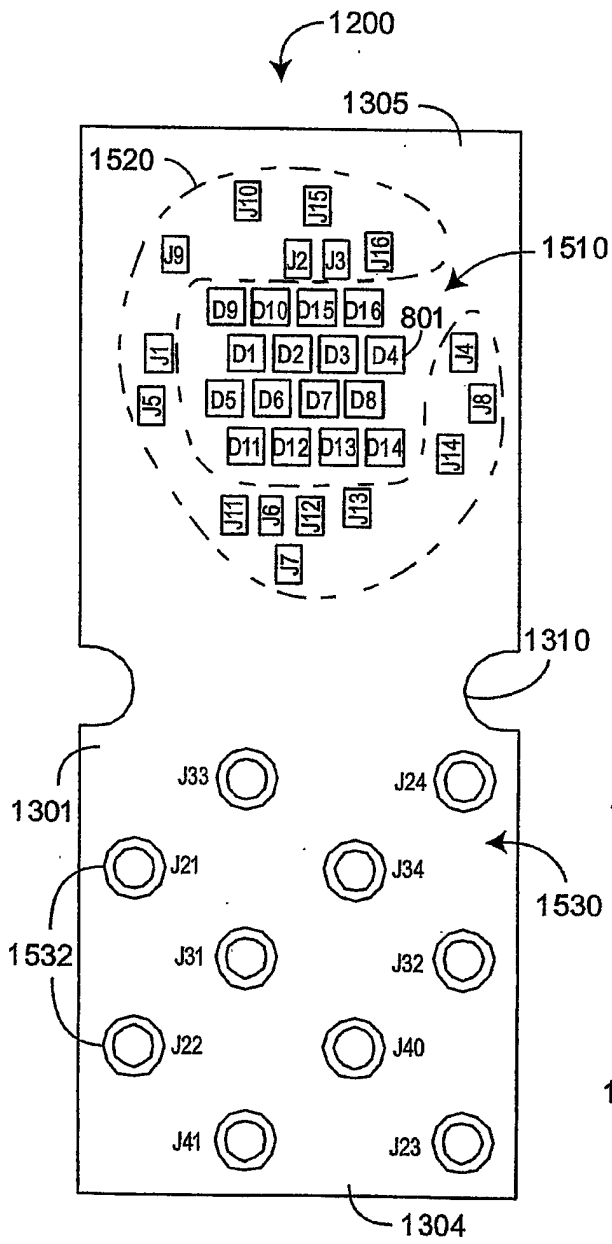

FIG. 15

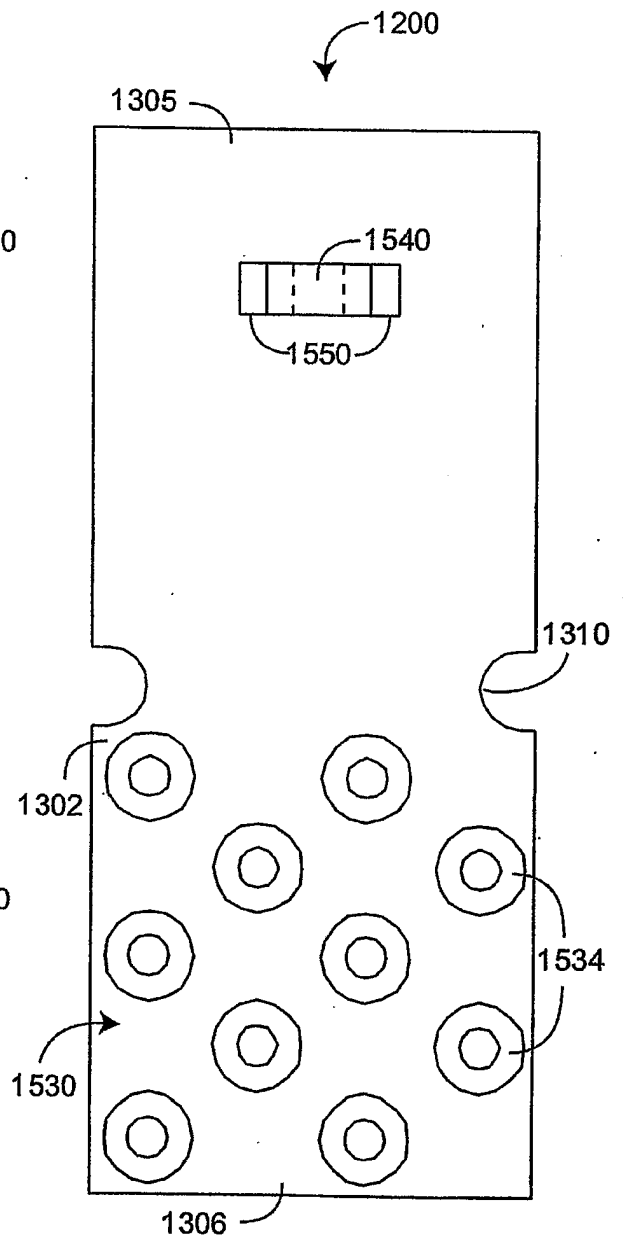

FIG. 16

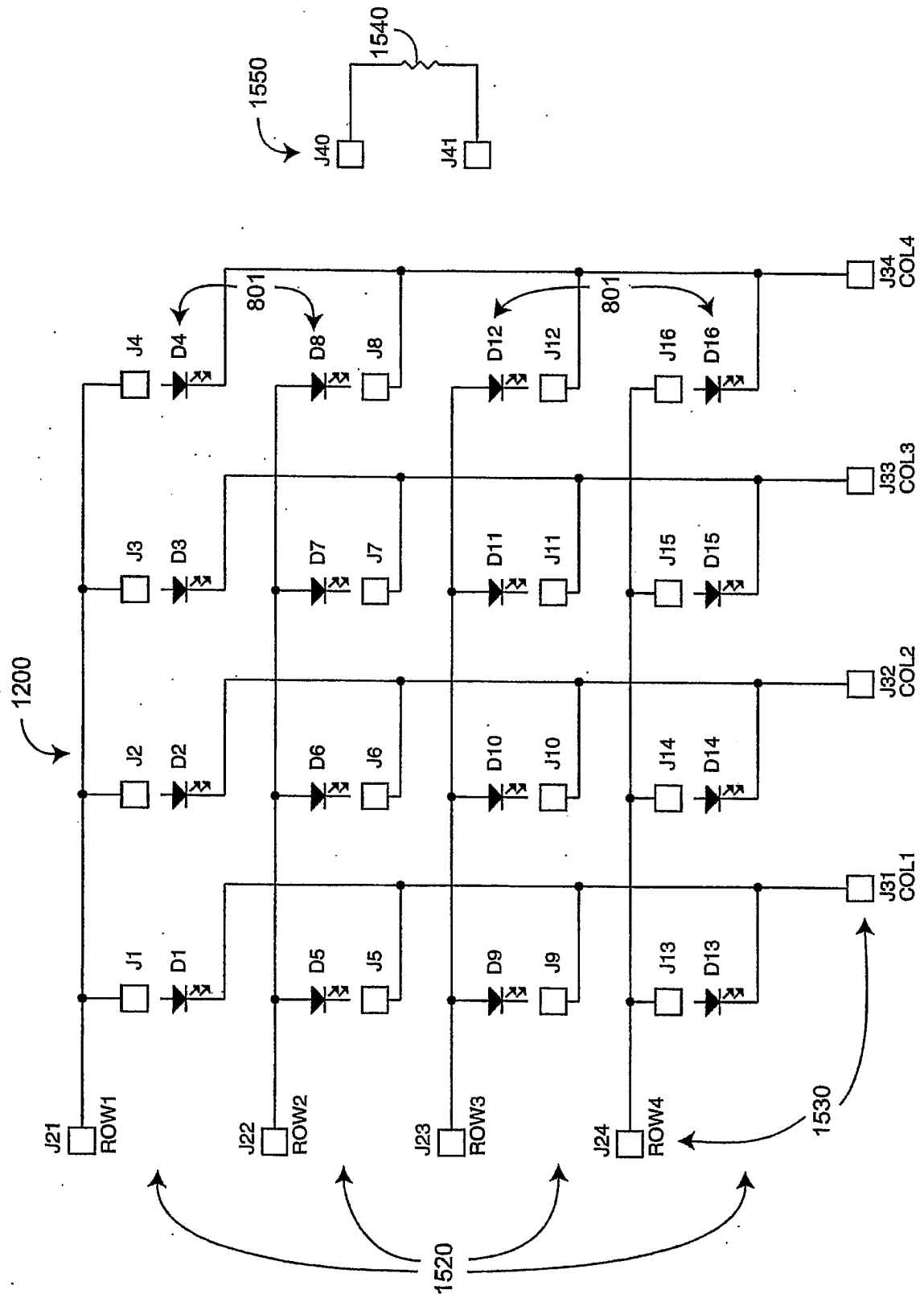

FIG. 17

1402

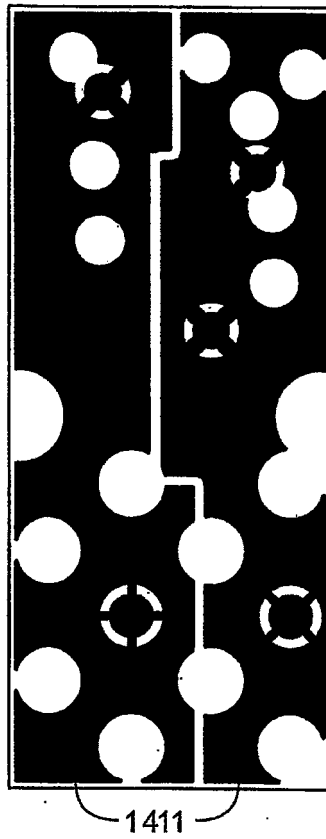

FIG. 18

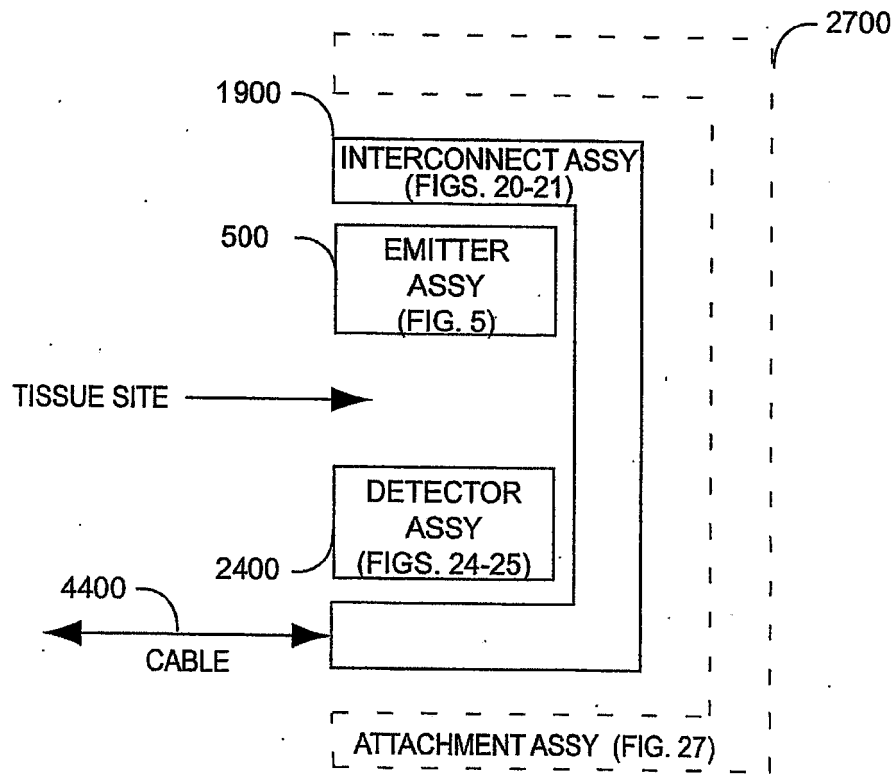

FIG. 19

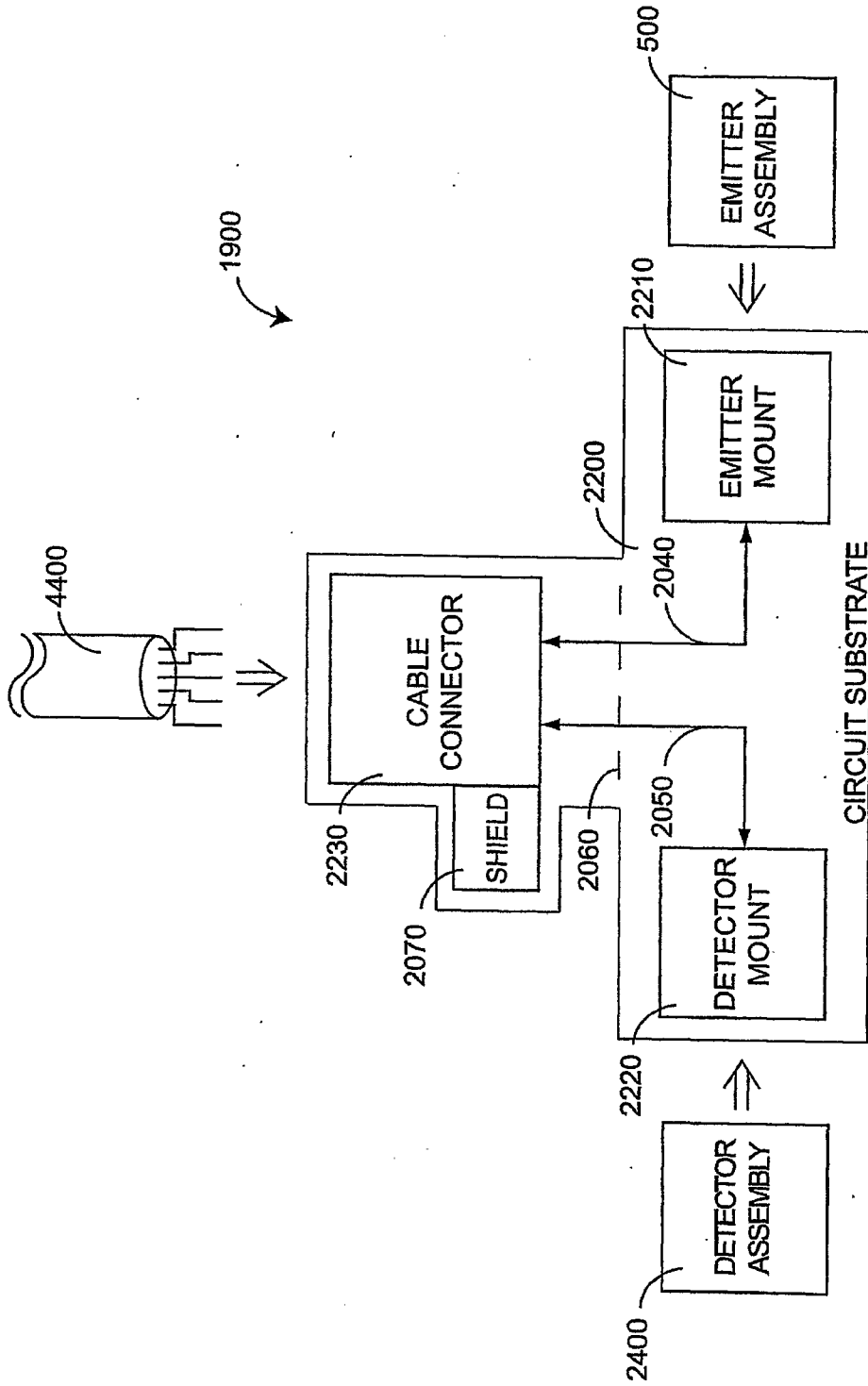

FIG. 20

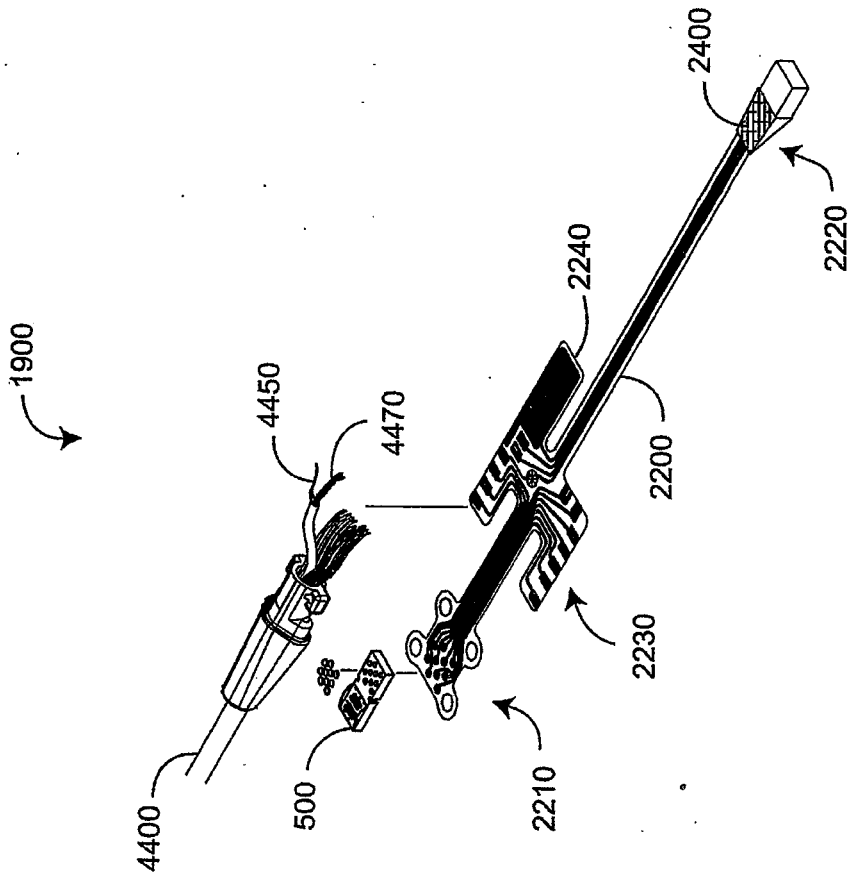

FIG. 21

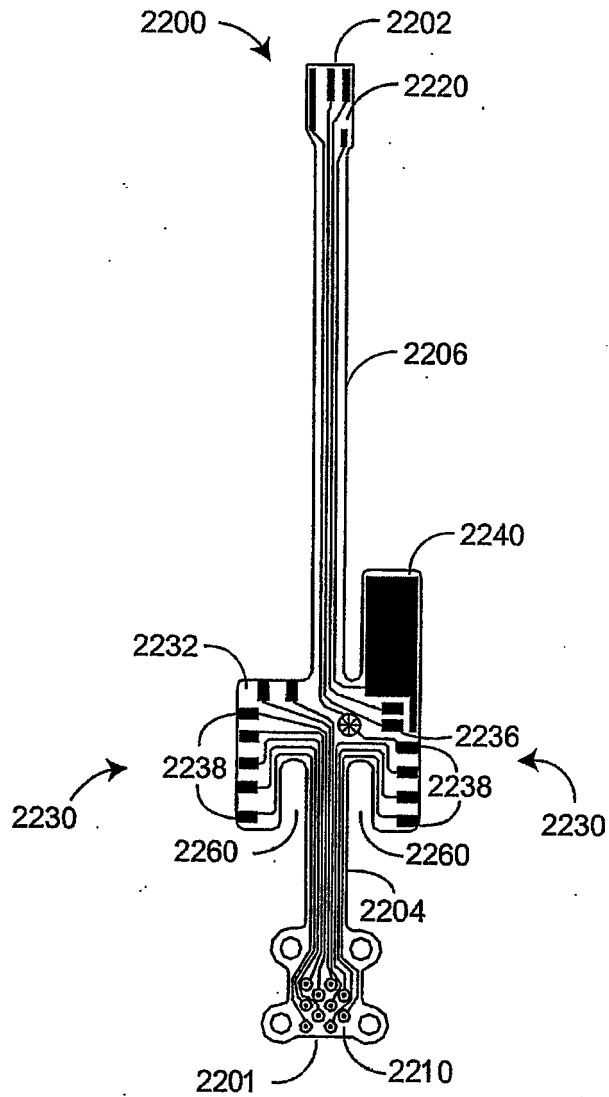

FIG. 22

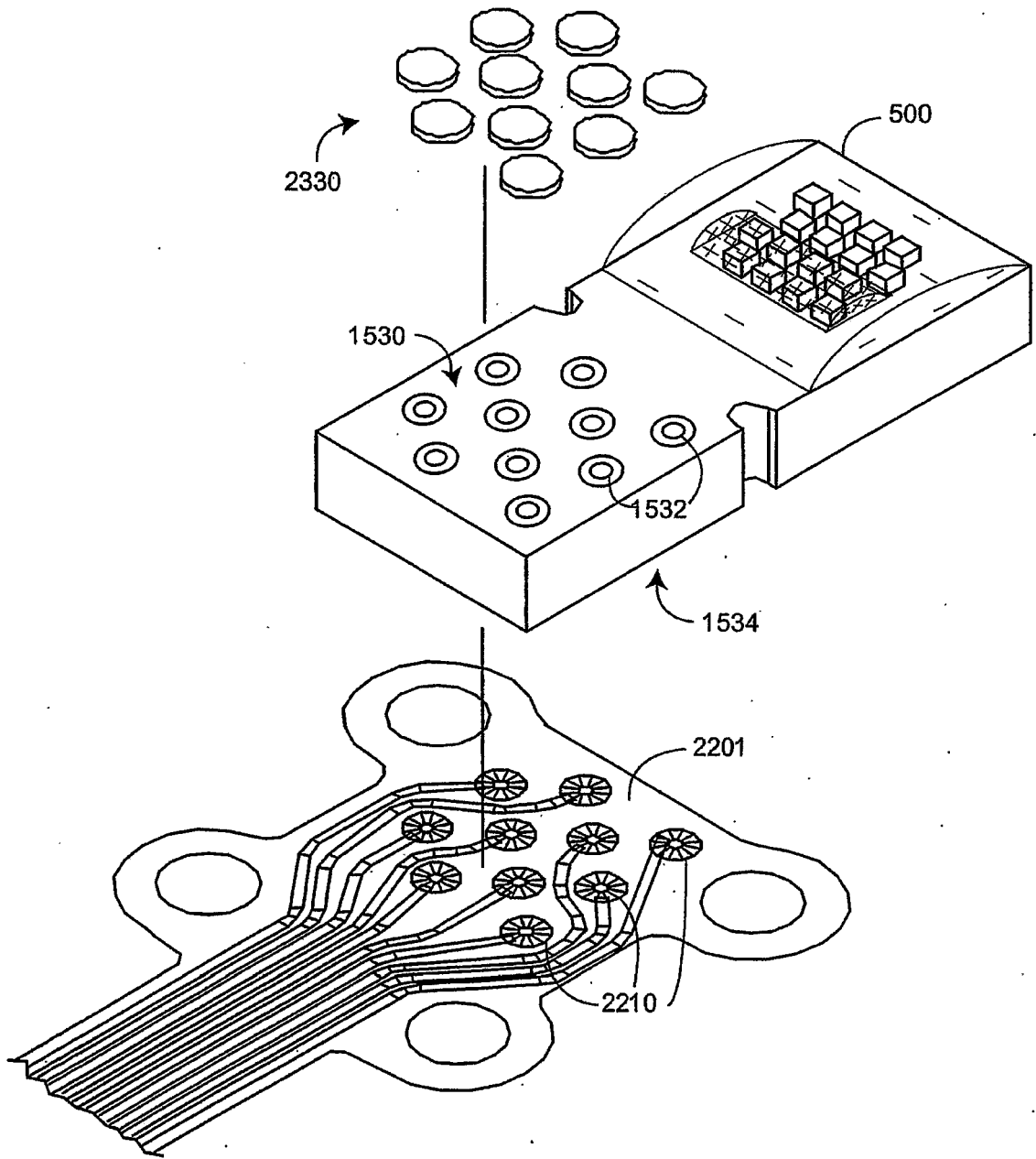

FIG. 23

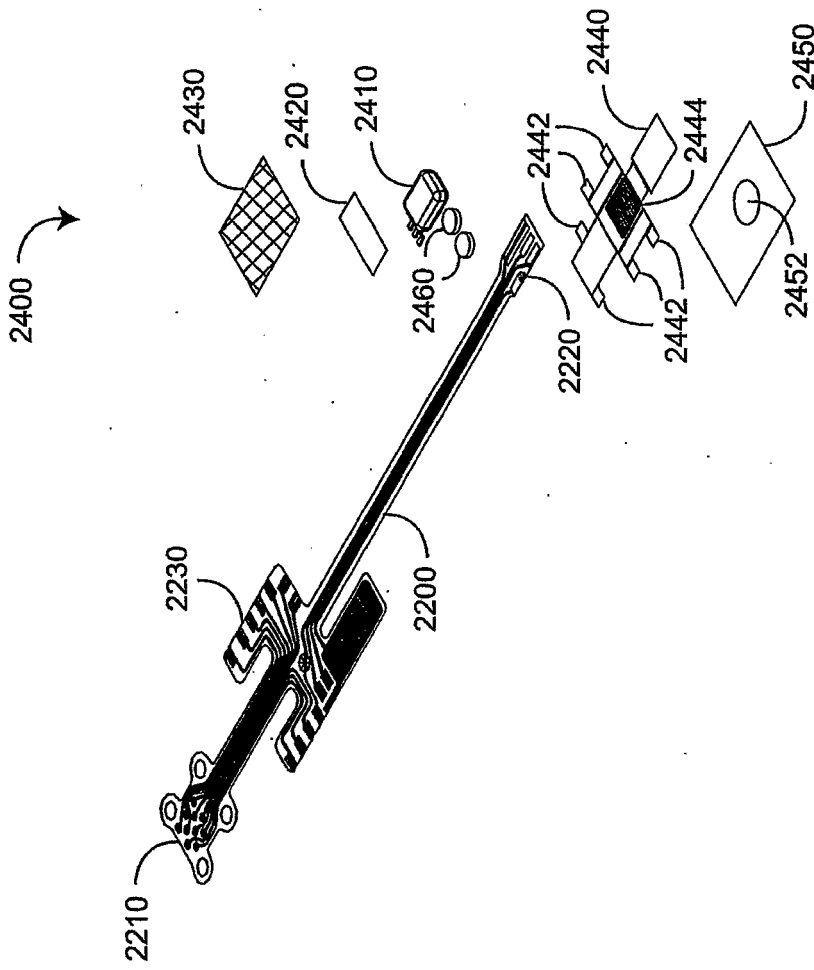

FIG. 24

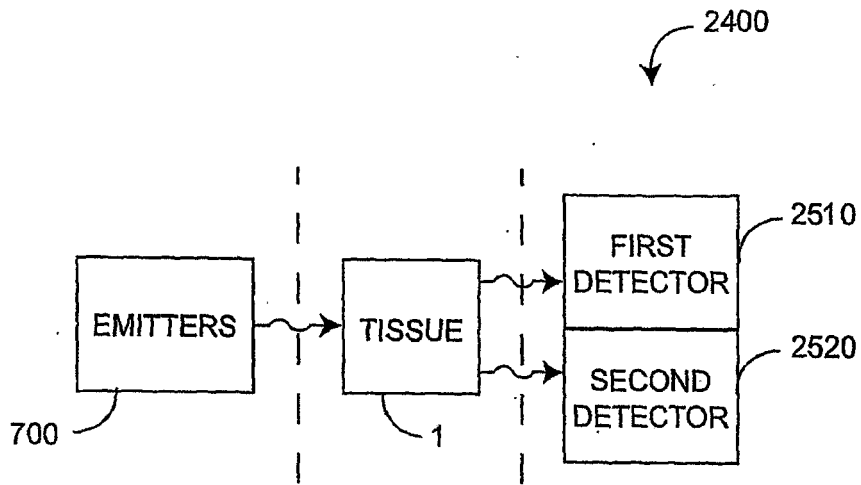

FIG. 25

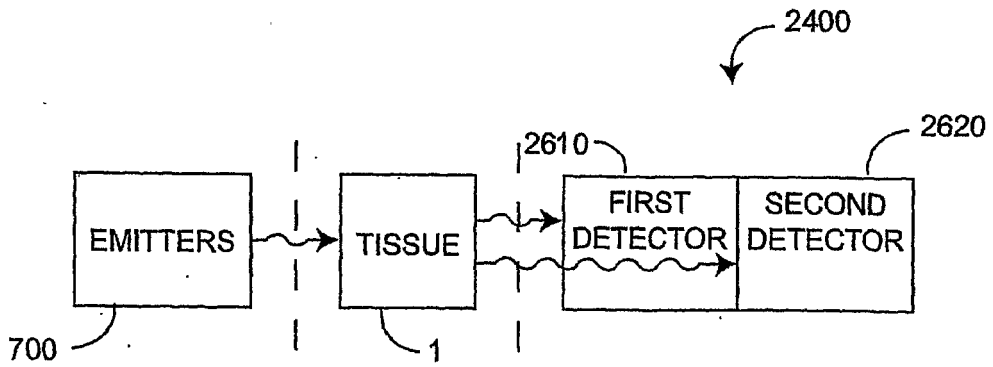

FIG. 26

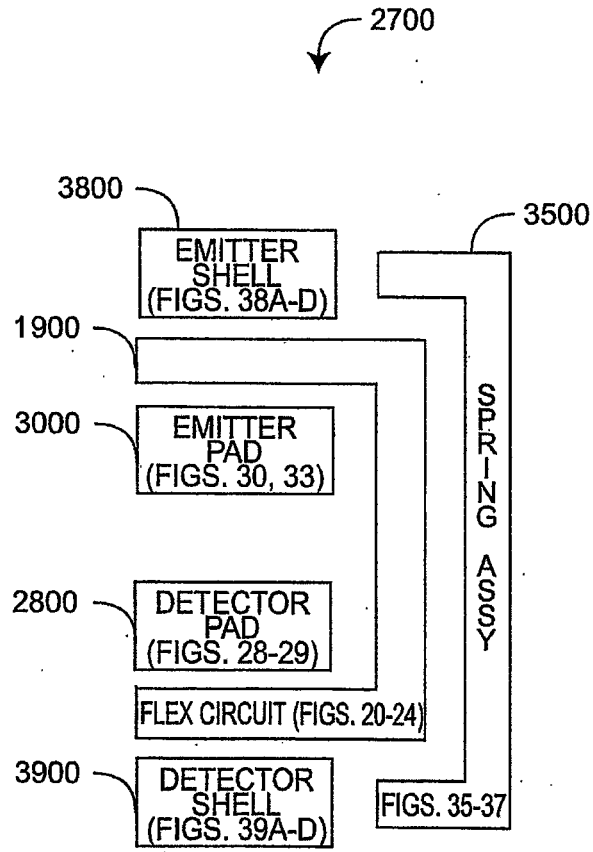

FIG. 27

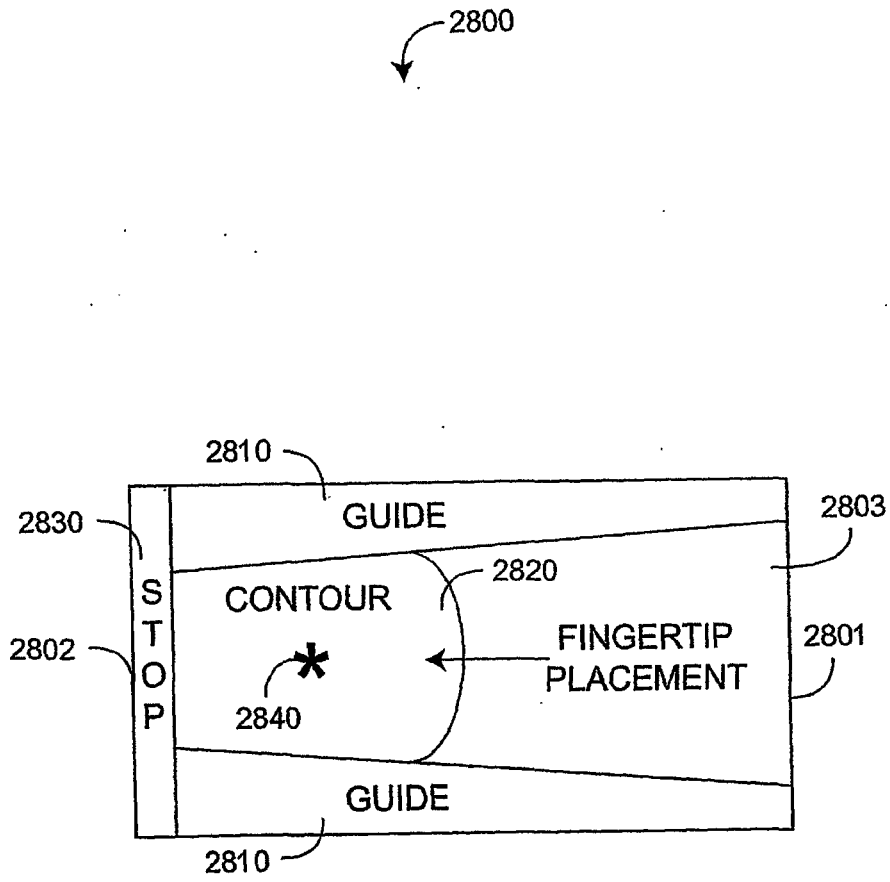

FIG. 28

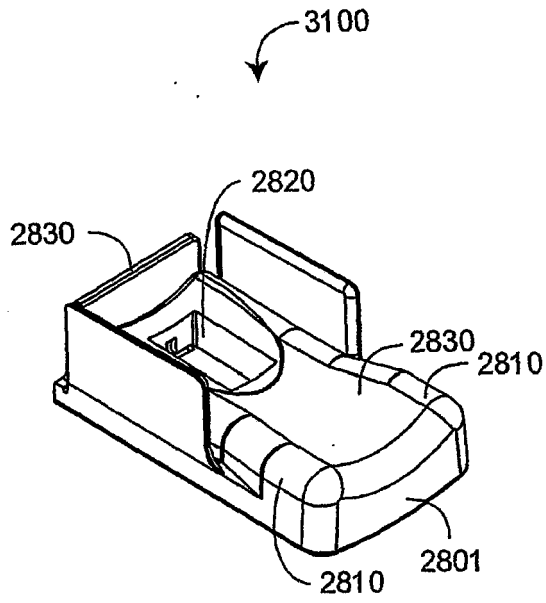

FIG. 29A

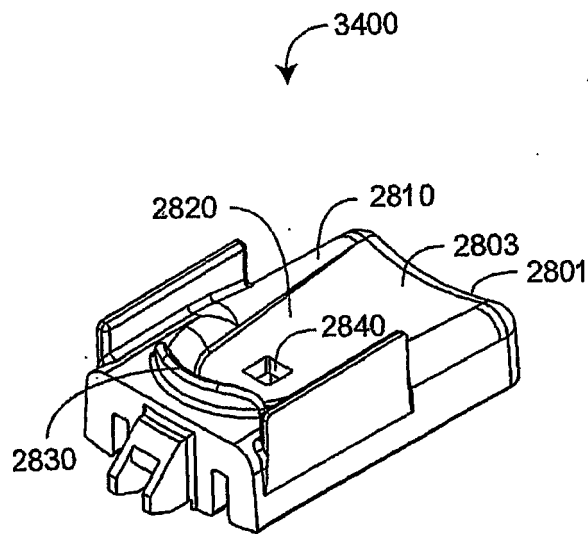

FIG. 29B

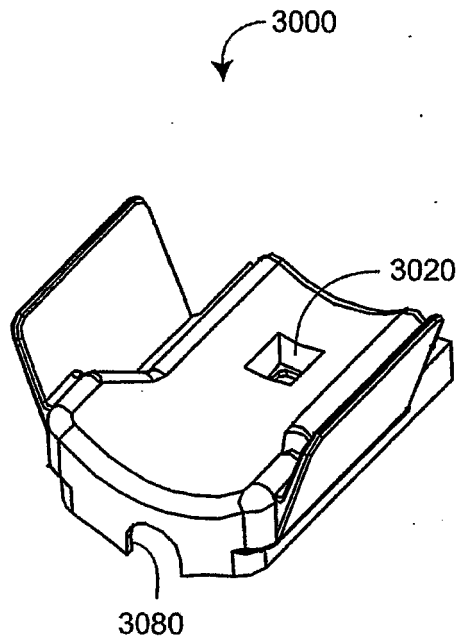

FIG. 30A

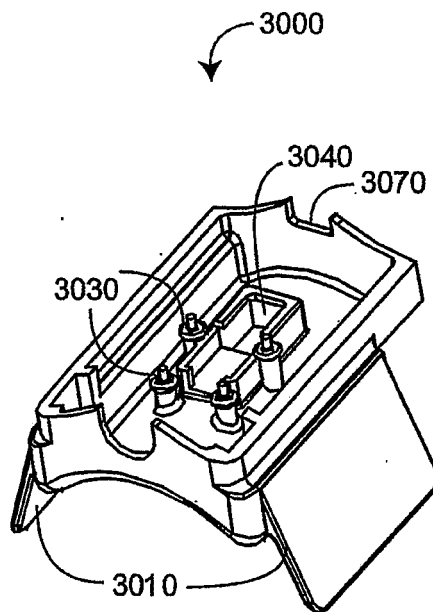

FIG. 30B

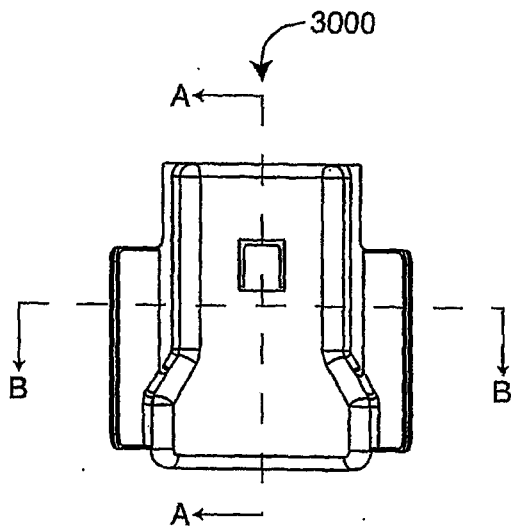
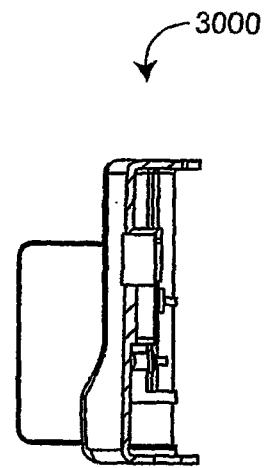

FIG. 30C



SECTION A-A

FIG. 30F

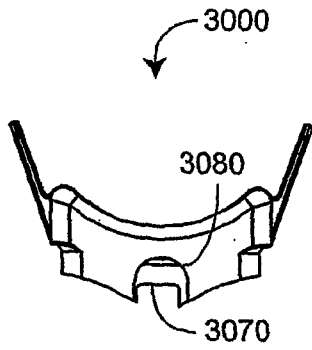

FIG. 30D

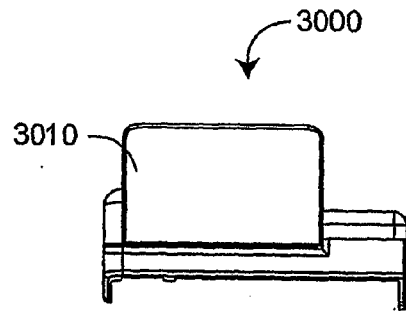

FIG. 30G

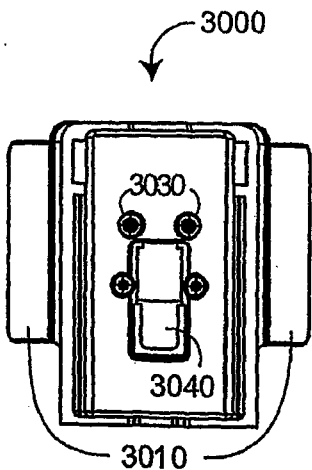
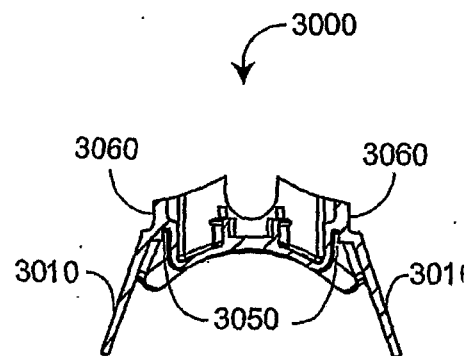

FIG. 30E



SECTION B-B

FIG. 30H

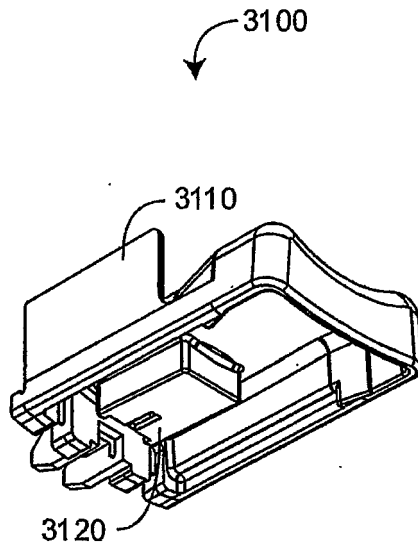

FIG. 31A

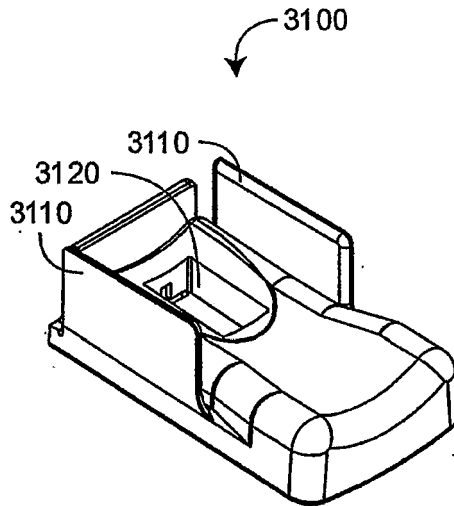

FIG. 31B

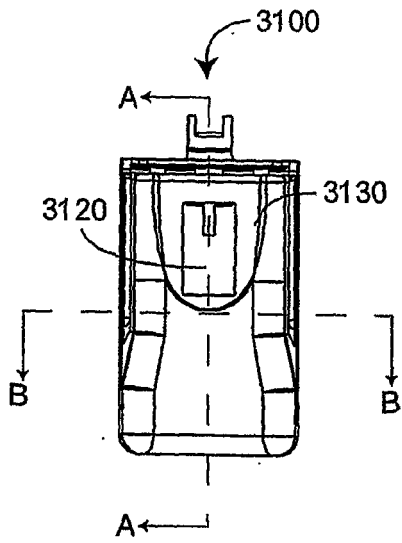
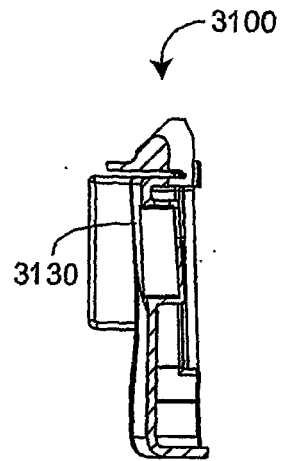

FIG. 31C



SECTION A-A

FIG. 31F

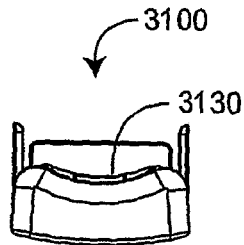

FIG. 31D

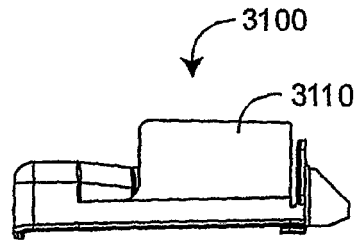

FIG. 31G

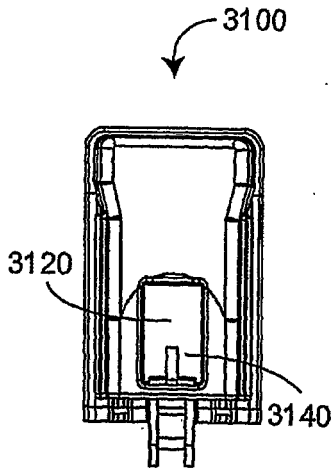
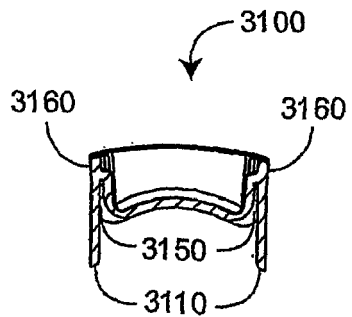

FIG. 31E



SECTION B-B

FIG. 31H

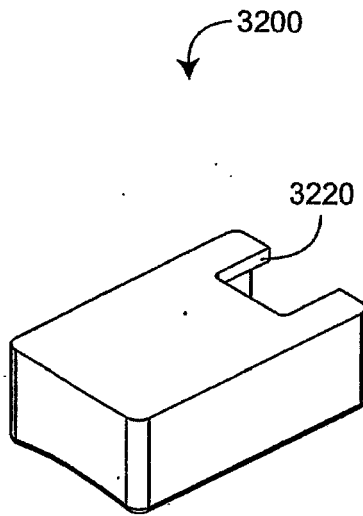

FIG. 32A

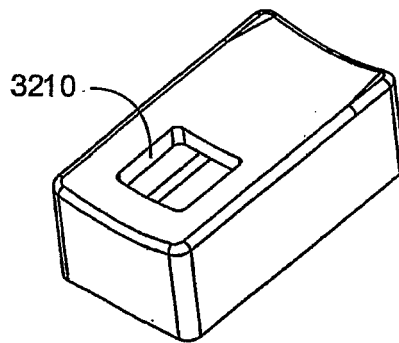

FIG. 32B

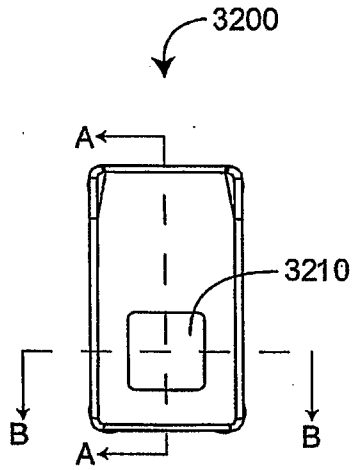
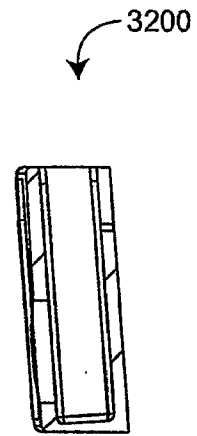

FIG. 32C



SECTION A-A
FIG. 32F

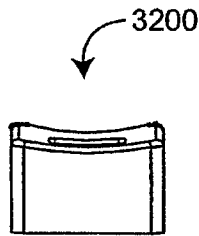

FIG. 32D

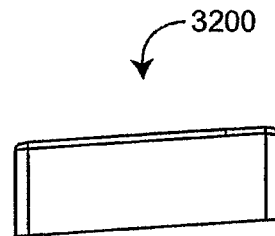

FIG. 32G

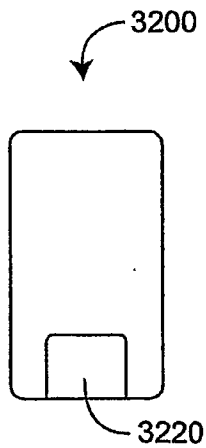
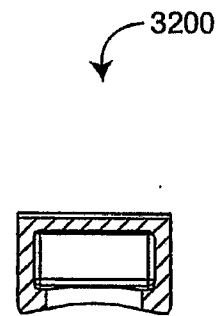

FIG. 32E



SECTION B-B
FIG. 32H

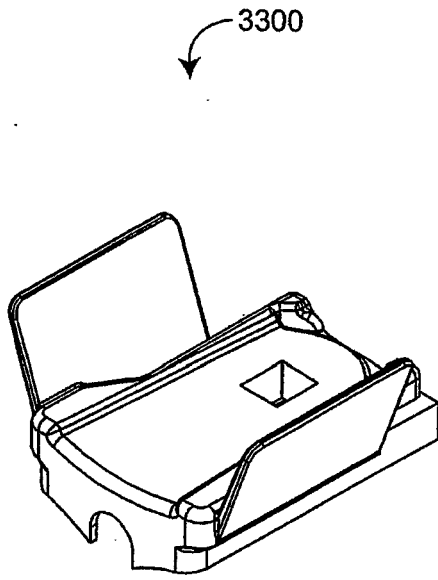

FIG. 33A

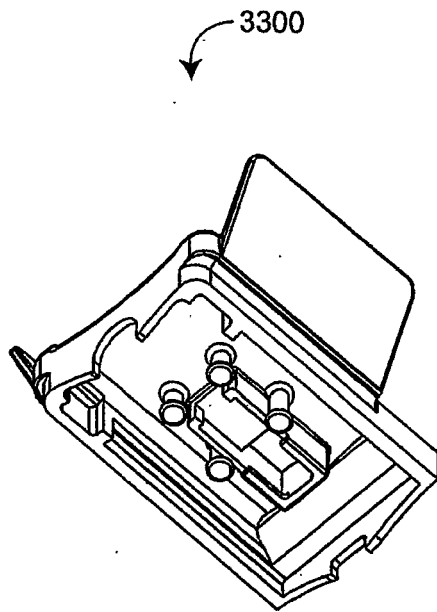

FIG. 33B

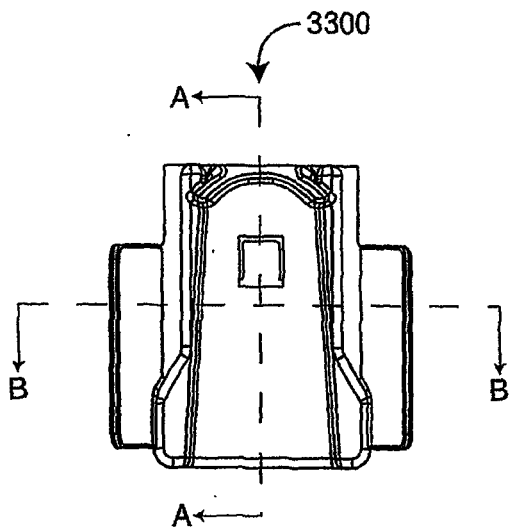
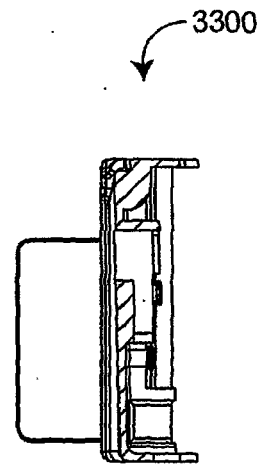

FIG. 33C



SECTION A-A

FIG. 33F

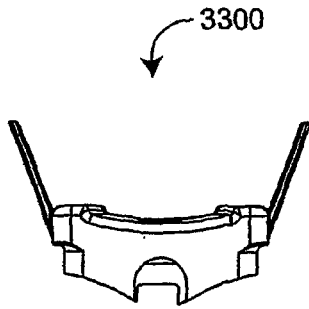

FIG. 33D

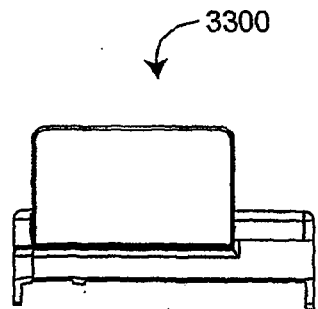

FIG. 33G

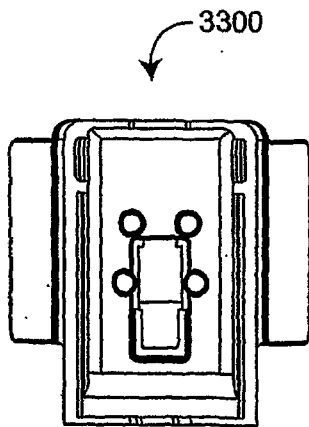
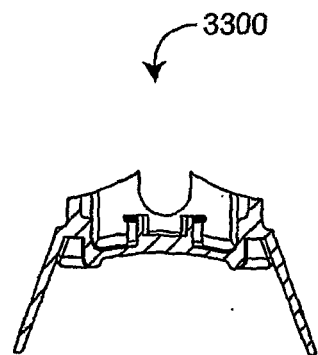

FIG. 33E



SECTION B-B

FIG. 33H

3400

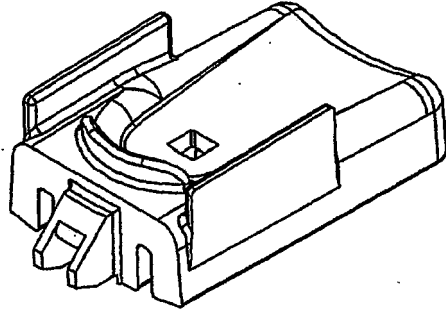

FIG. 34A

3400

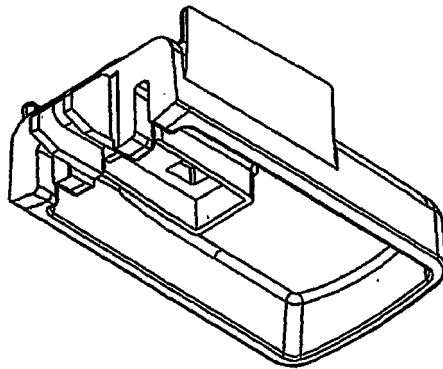

FIG. 34B

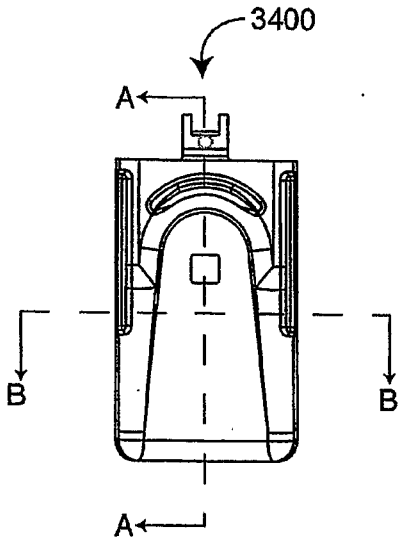
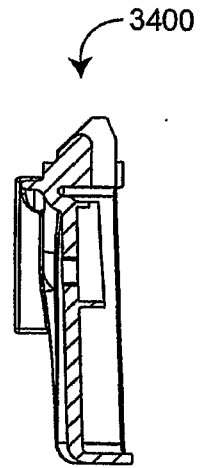

FIG. 34C



SECTION A-A

FIG. 34F

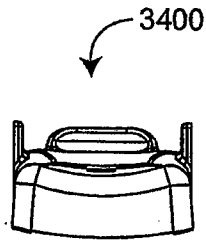

FIG. 34D

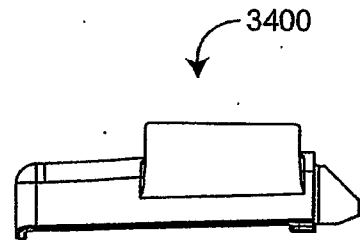

FIG. 34G

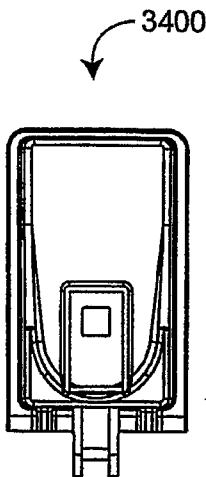
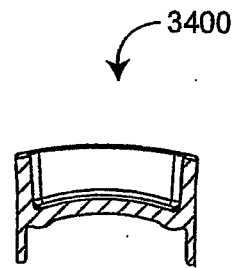

FIG. 34E



SECTION B-B

FIG. 34H

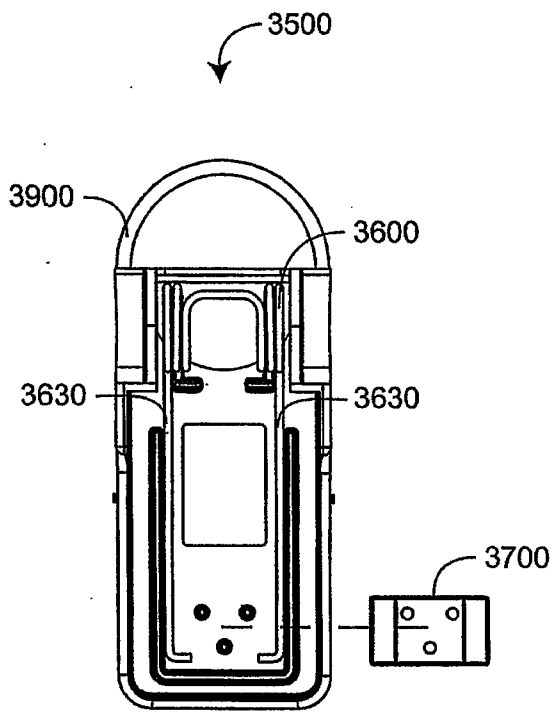

FIG. 35A

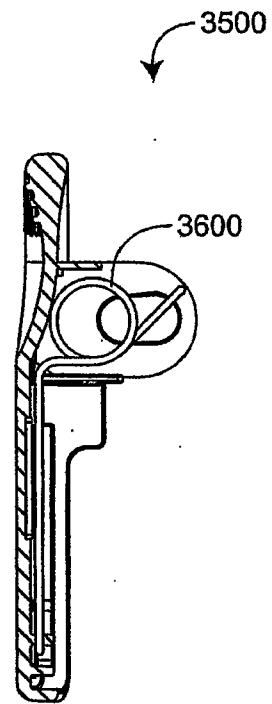

FIG. 35B

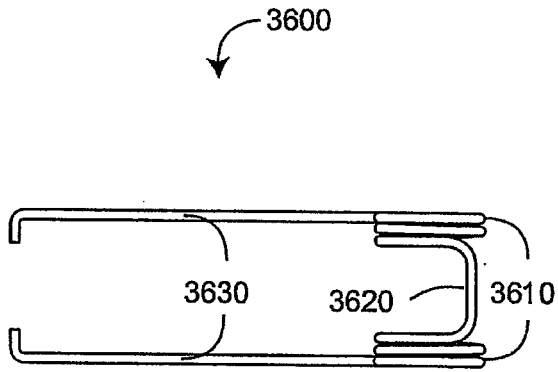

FIG. 36A

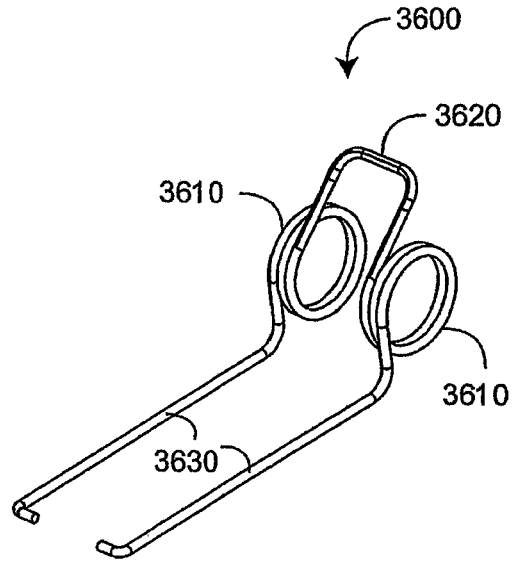

FIG. 36B

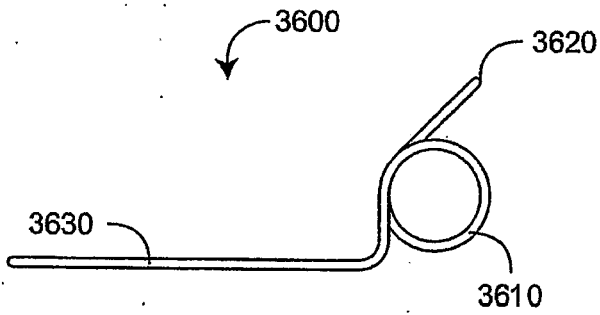

FIG. 36C

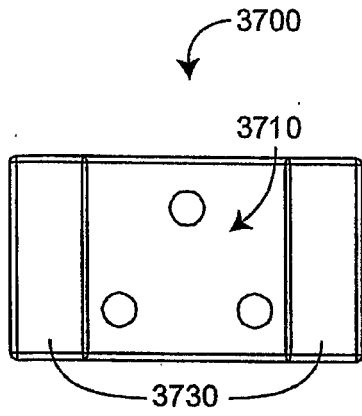

FIG. 37A

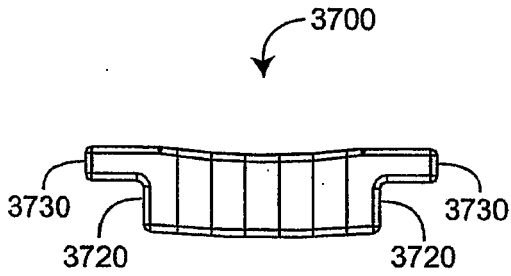

FIG. 37B

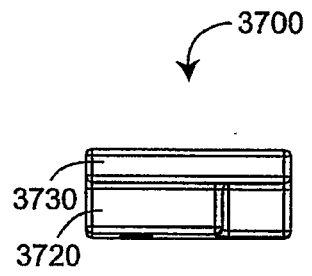

FIG. 37D

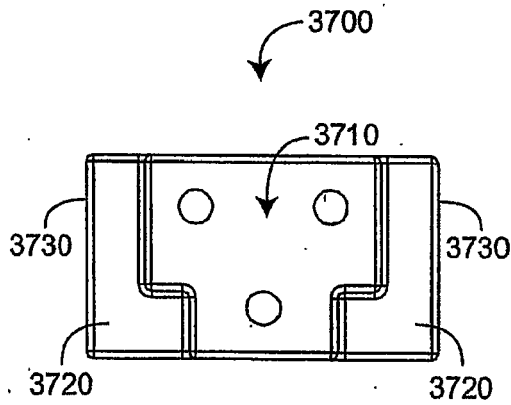

FIG. 37C

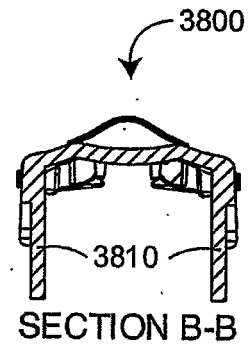

FIG. 38A

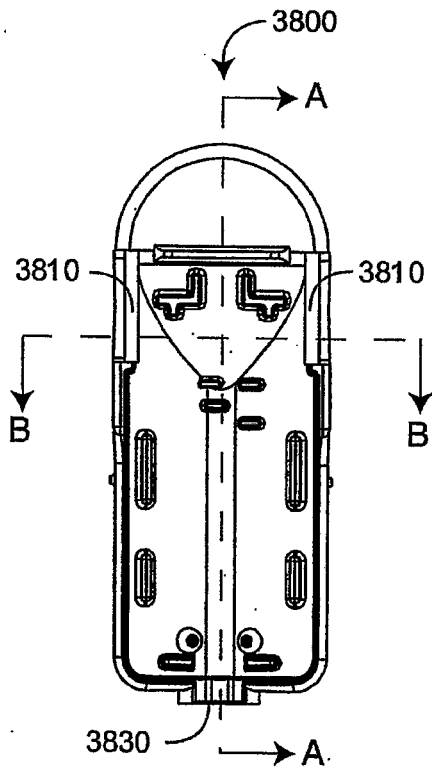
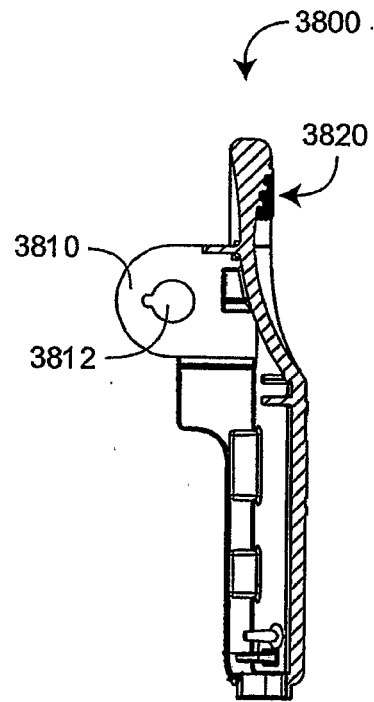

FIG. 38B



SECTION A-A
FIG. 38D

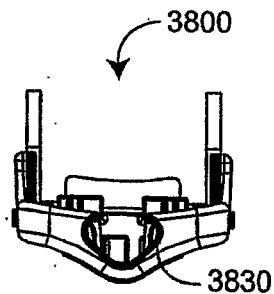

FIG. 38C

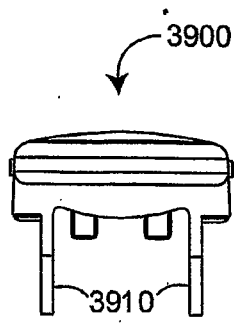

FIG. 39A

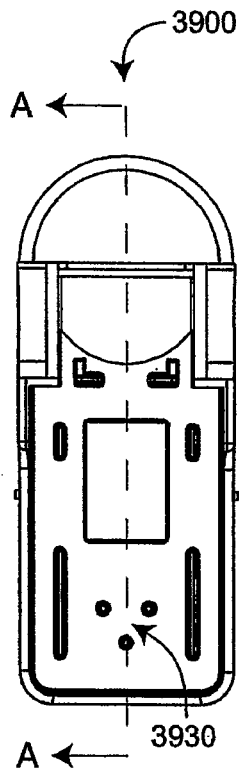

FIG. 39B

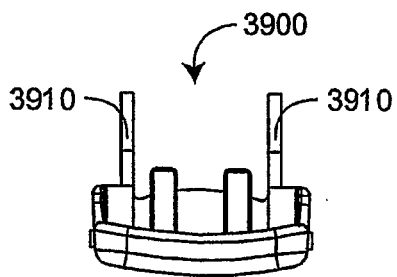
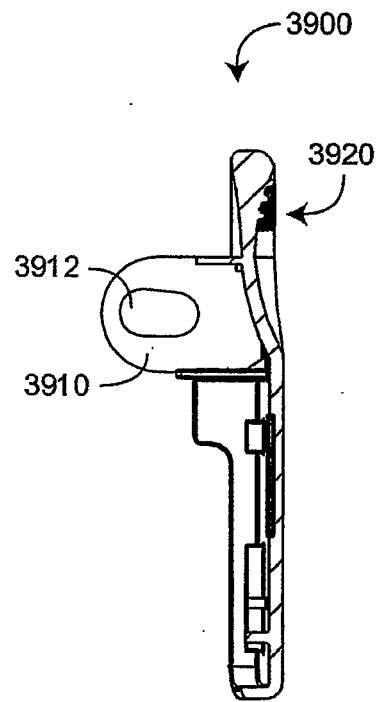

FIG. 39C



SECTION A-A
FIG. 39D

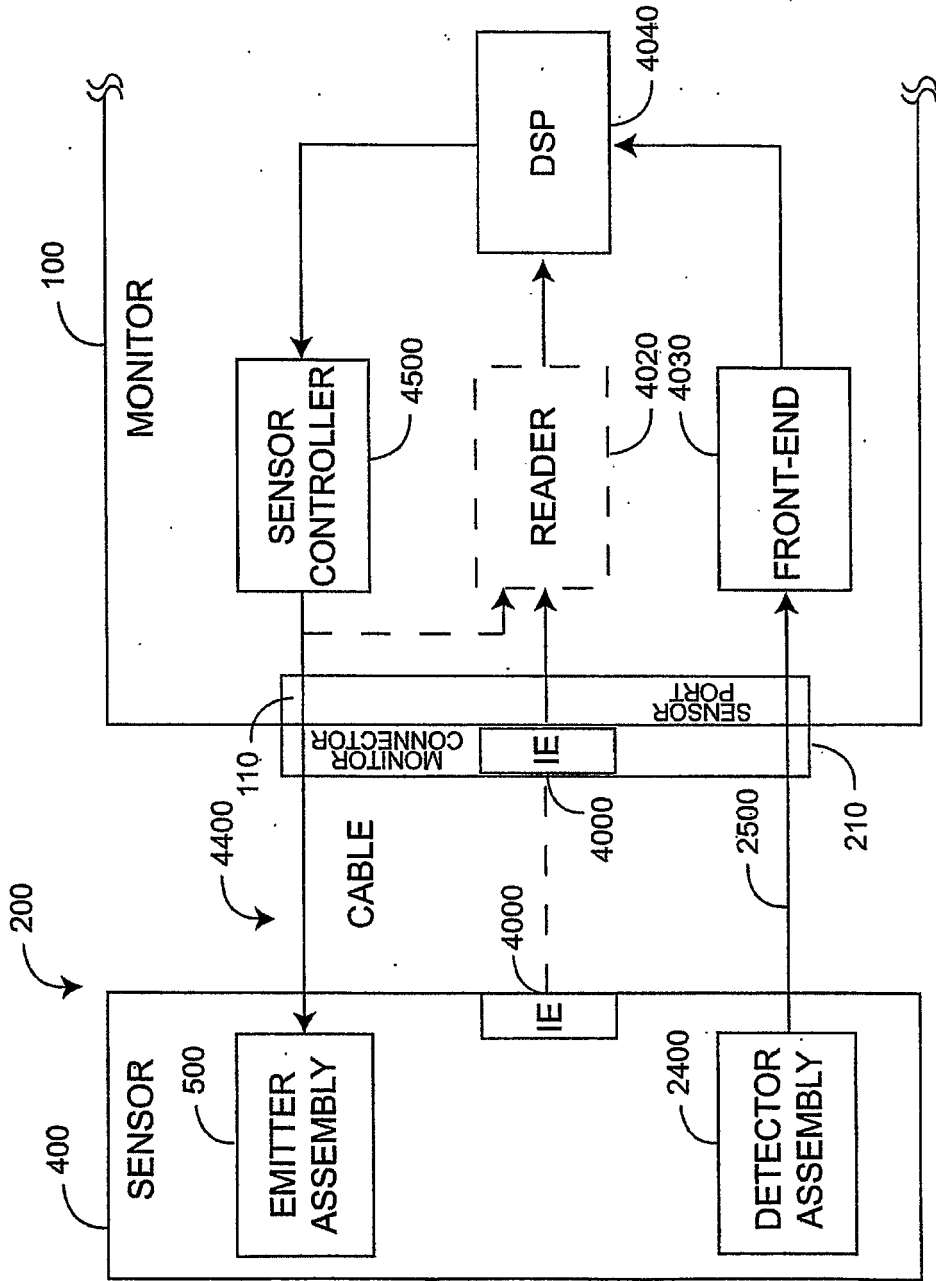

FIG. 40

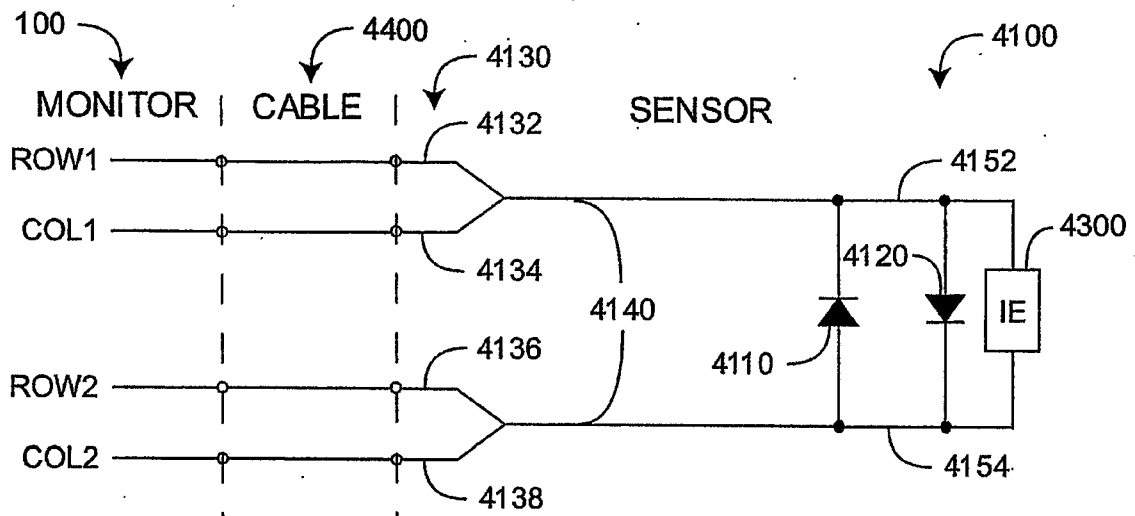

FIG. 41A

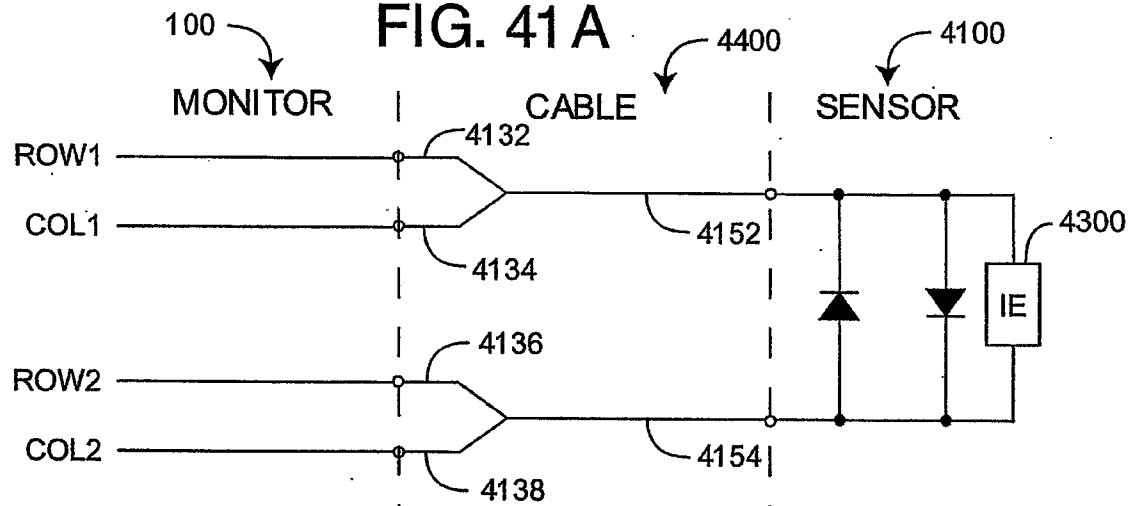

FIG. 41B

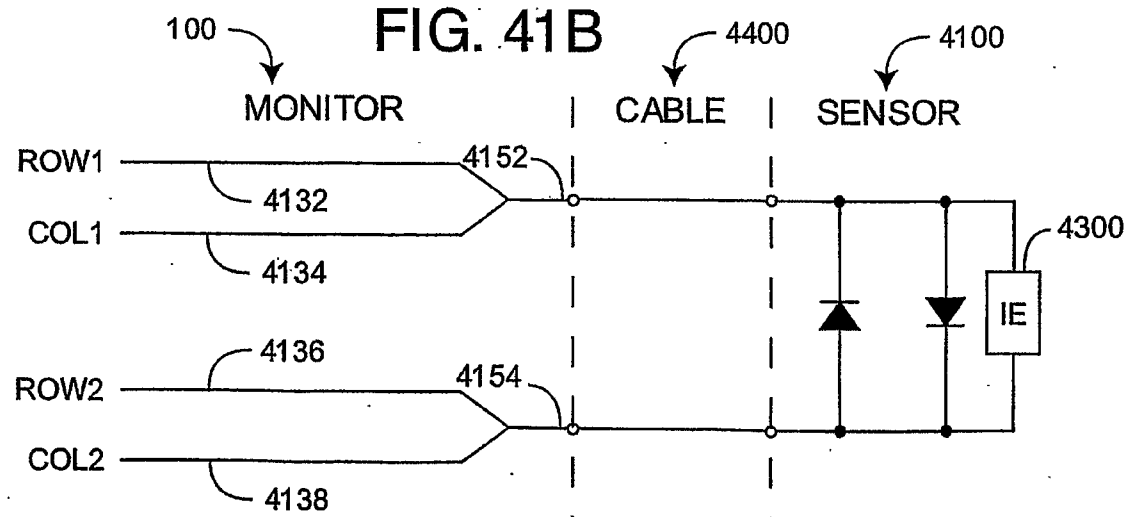

FIG. 41C

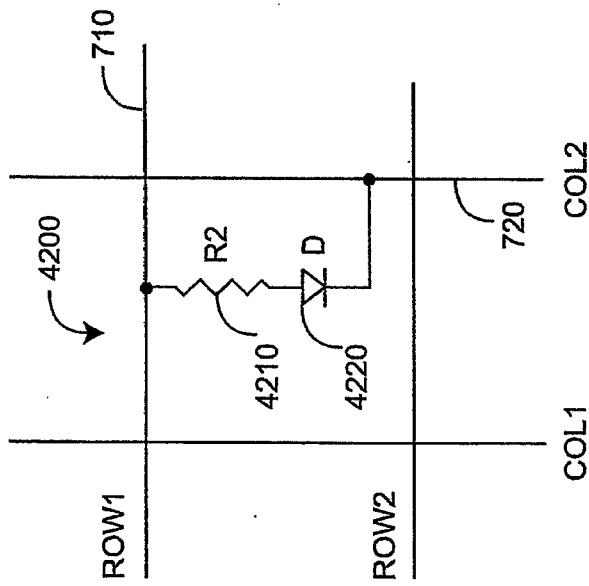

FIG. 42

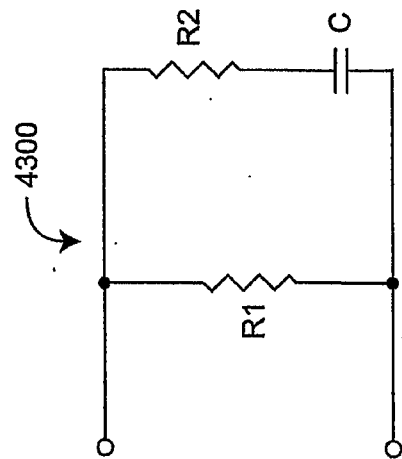

FIG. 43A

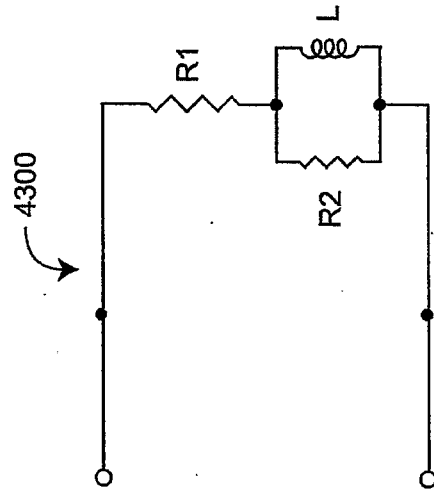

FIG. 43B

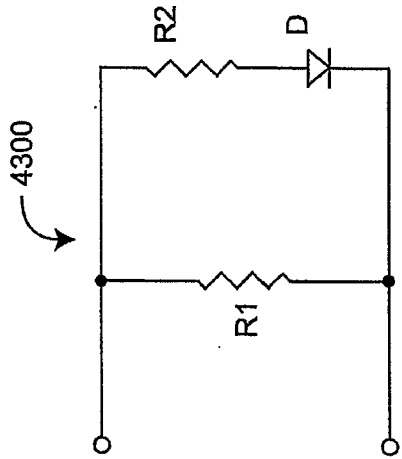

FIG. 43C

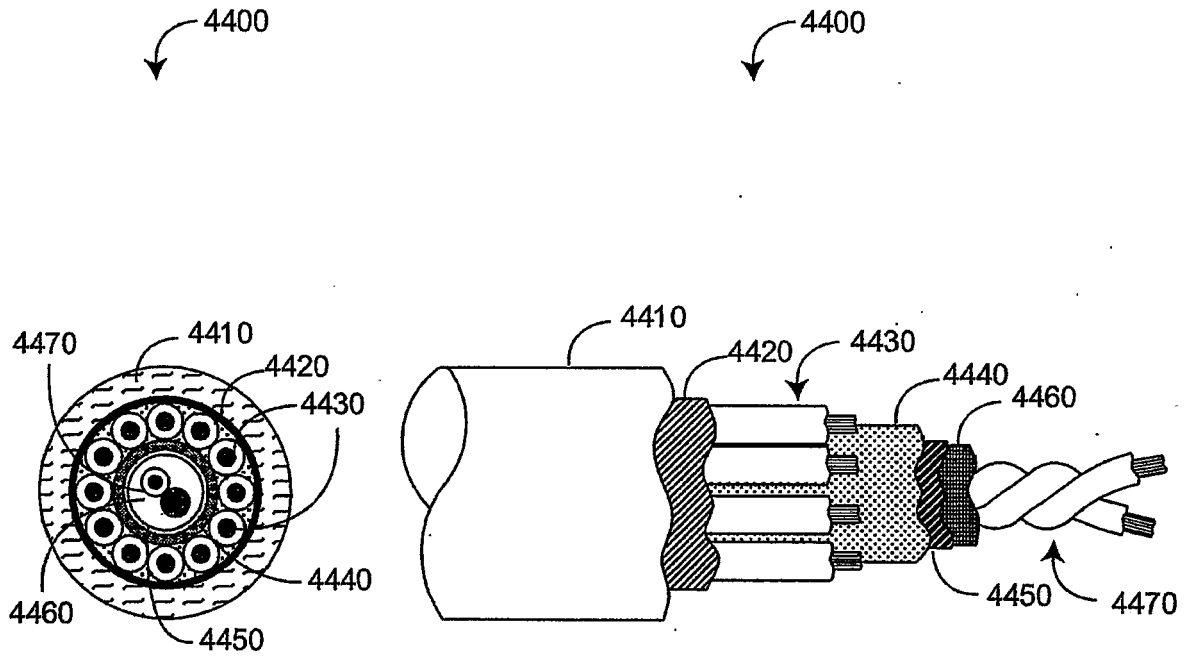

FIG. 44A

FIG. 44B

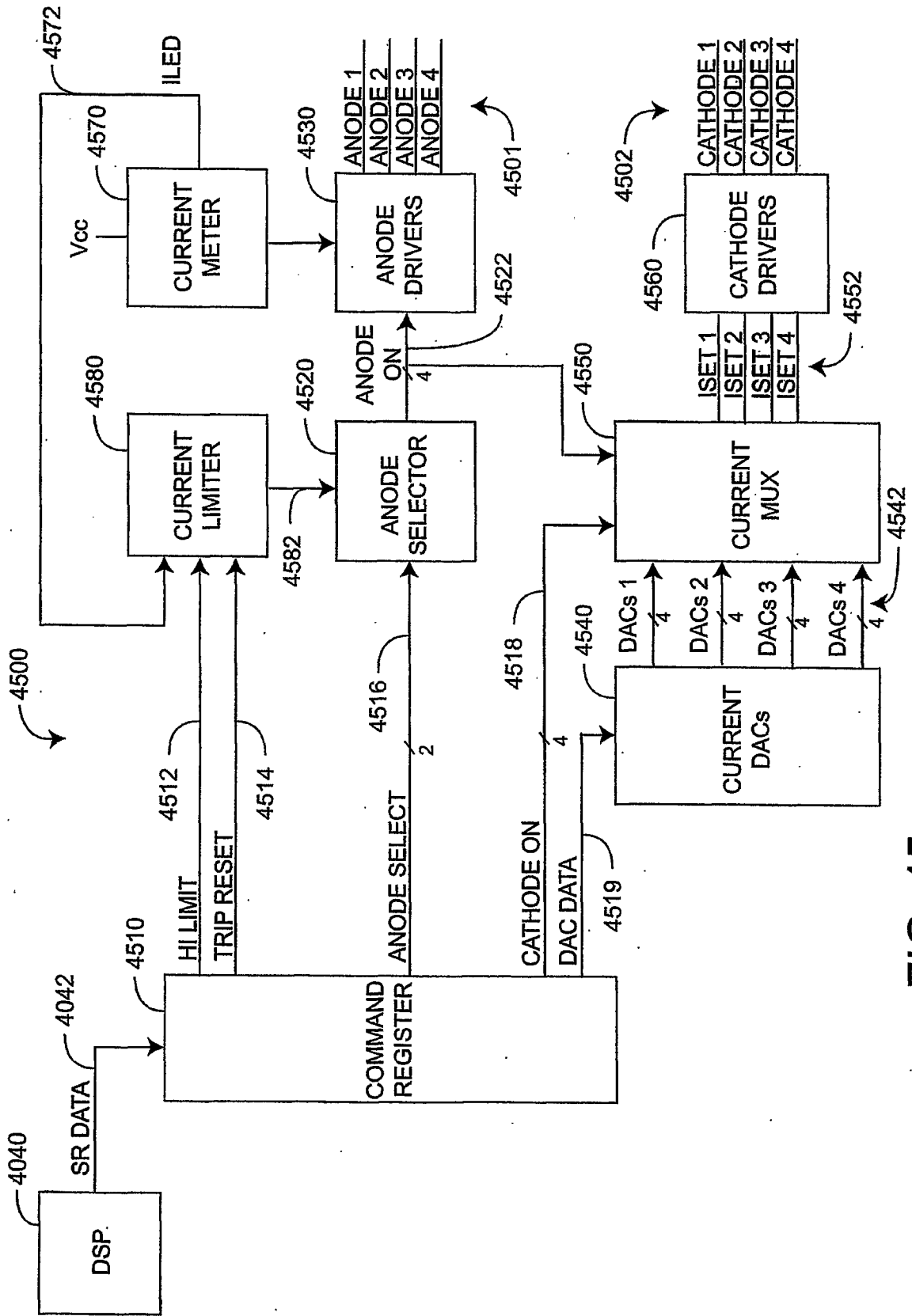

FIG. 45

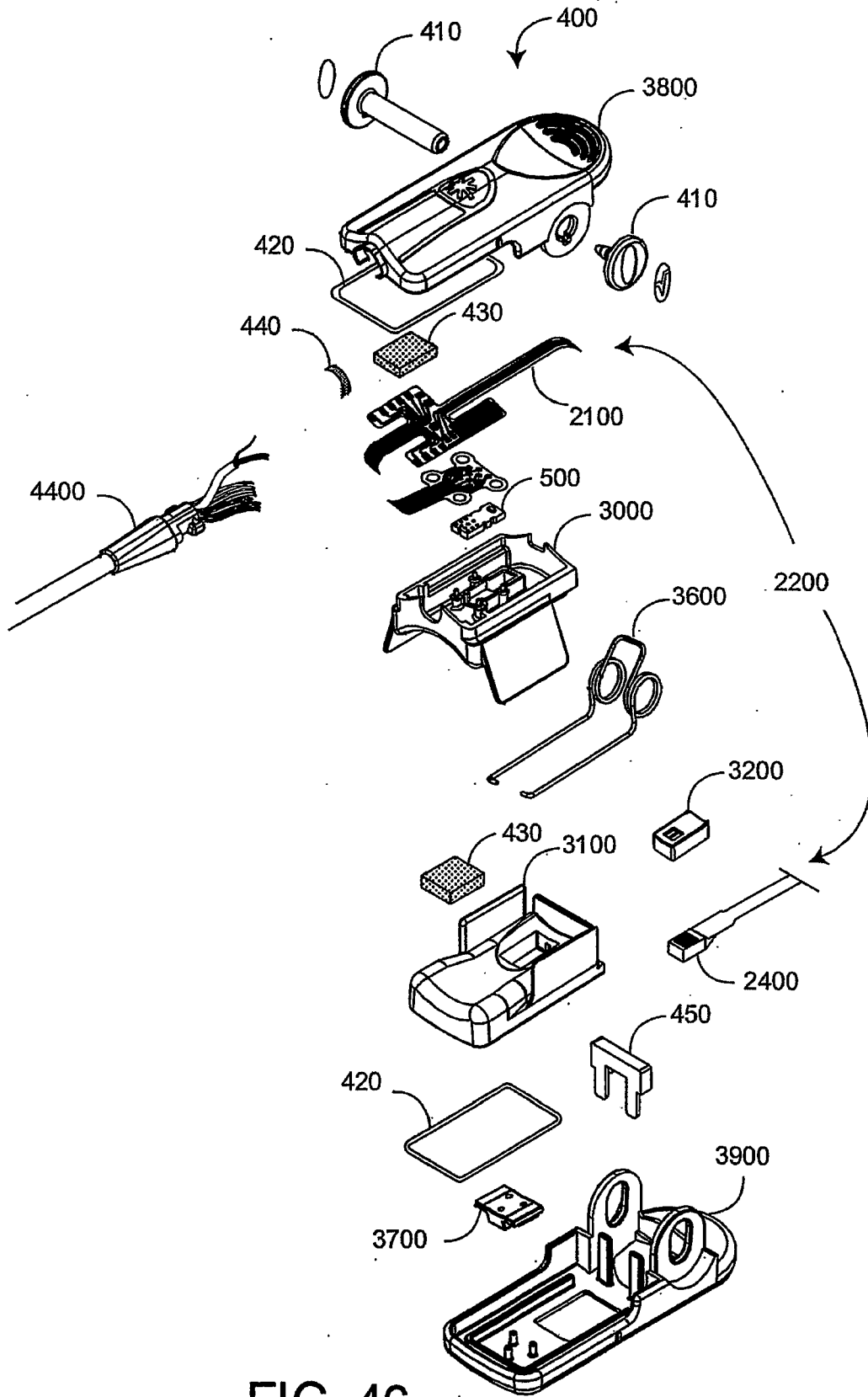

FIG. 46

REFERENCES CITED IN THE DESCRIPTION

This list of references cited by the applicant is for the reader's convenience only. It does not form part of the European patent document. Even though great care has been taken in compiling the references, errors or omissions cannot be excluded and the EPO disclaims all liability in this regard.

Patent documents cited in the description

- US 6770028 B [0002]
- US 6658276 B [0002]
- US 6157850 A [0002]
- US 6002952 A [0002]
- US 5769785 A [0002]
- US 5758644 A [0002]

专利名称(译)	多波长传感器驱动器		
公开(公告)号	EP2305104B1	公开(公告)日	2018-10-17
申请号	EP2010193356	申请日	2006-03-01
[标]申请(专利权)人(译)	MASIMO LAB		
申请(专利权)人(译)	MASIMO实验室, INC.		
当前申请(专利权)人(译)	MASIMO实验室, INC.		
[标]发明人	AL ALI AMMAR SMITH ROBERT DALKE DAVID LAMEGO MARCELO DIAB MOHAMED		
发明人	AL-ALI, AMMAR SMITH, ROBERT DALKE, DAVID LAMEGO, MARCELO DIAB, MOHAMED		
IPC分类号	A61B5/00		
CPC分类号	A61B5/02416 A61B5/14552 A61B5/6832 A61B5/746 A61B2562/08 A61B2562/085 A61B2562/222 G06F19/3418 G16H10/40 G16H40/67 Y10S439/909 A61B1/00 A61B5/0022 A61B5/0205 A61B5/02427 A61B5/0261 A61B5/0295 A61B5/14532 A61B5/14546 A61B5/1455 A61B5/14551 A61B5/1495 A61B5 /6815 A61B5/6826 A61B5/6829 A61B5/6838 A61B5/7221 A61B5/7246 A61B5/7275 A61B5/7278 A61B5/7405 A61B5/742 A61B5/7475 H05K999/99		
优先权	60/657596 2005-03-01 US 60/657759 2005-03-01 US 60/657268 2005-03-01 US 60/657281 2005-03-01 US PCT/US2006/007539 2006-03-01 WO		
其他公开文献	EP2305104A3 EP2305104A2		
外部链接	Espacenet		

摘要(译)

本发明涉及一种在患者监视器上显示生理参数的颜色编码指示的方法，该方法包括非侵入地确定第一生理参数的至少一个测量值和第二生理参数的至少一个测量值，将第一生理参数与第一生理参数相关联。具有第一颜色的生理参数，将第二生理参数与不同于第一颜色的第二颜色相关联，在患者监视器上显示具有第一颜色的第一指示，第一指示指示至少一个测量值第一生理参数，并在患者监视器上显示具有第二颜色的第二指示，第二指示指示第二生理参数的至少一个测量值。

$$I_{\lambda} = I_{0,\lambda} e^{-d_{\lambda} \cdot \mu_{a,\lambda}}$$

(1)