

(19) World Intellectual Property Organization
International Bureau



(43) International Publication Date
13 September 2007 (13.09.2007)

PCT

(10) International Publication Number
WO 2007/101343 A1

(51) International Patent Classification:

- A61B 5/00 (2006.01)
- A47C 17/86 (2006.01)
- A47C 7/62 (2006.01)
- A61B 5/024 (2006.01)
- A61B 5/08 (2006.01)
- A61B 5/11 (2006.01)
- G01S 13/04 (2006.01)
- G01S 13/50 (2006.01)
- G01S 13/88 (2006.01)
- G01S 7/04 (2006.01)
- G01S 7/32 (2006.01)
- G01S 7/41 (2006.01)
- G08B 21/02 (2006.01)
- G08C 17/02 (2006.01)
- H01Q 1/36 (2006.01)
- A61B 5/0255 (2006.01)

(71) Applicant (for all designated States except US): WIRELESS 2000 RF & UWB TECHNOLOGIES LTD. [CA/CA]; 2421 Alpha Avenue, Burnaby, British Columbia V5C 2L2 (CA).

(72) Inventor; and

(75) Inventor/Applicant (for US only): FOO, Senglee [CA/CA]; 543 - 1979 Marine Drive, North Vancouver, British Columbia V7P 3G2 (CA).

(21) International Application Number:

PCT/CA2007/000365

(74) Agents: MANNING, Gavin N. et al.; Oyen Wiggs Green & Mutala Llp, 480 - The Station, 601 West Cordova Street, Vancouver, British Columbia V6B 1G1 (CA).

(22) International Filing Date: 6 March 2007 (06.03.2007)

(81) Designated States (unless otherwise indicated, for every kind of national protection available): AE, AG, AL, AM, AT, AU, AZ, BA, BB, BG, BR, BW, BY, BZ, CA, CH, CN, CO, CR, CU, CZ, DE, DK, DM, DZ, EC, EE, EG, ES, FI, GB, GD, GE, GH, GM, GT, HN, HR, HU, ID, IL, IN, IS, JP, KE, KG, KM, KN, KP, KR, KZ, LA, LC, LK, LR, LS, LT, LU, LY, MA, MD, MG, MK, MN, MW, MX, MY, MZ, NA, NG, NI, NO, NZ, OM, PG, PH, PL, PT, RO, RS, RU,

(25) Filing Language: English

(26) Publication Language: English

(30) Priority Data:
60/778,908 6 March 2006 (06.03.2006) US

[Continued on next page]

(54) Title: ULTRA WIDEBAND MONITORING SYSTEMS AND ANTENNAS

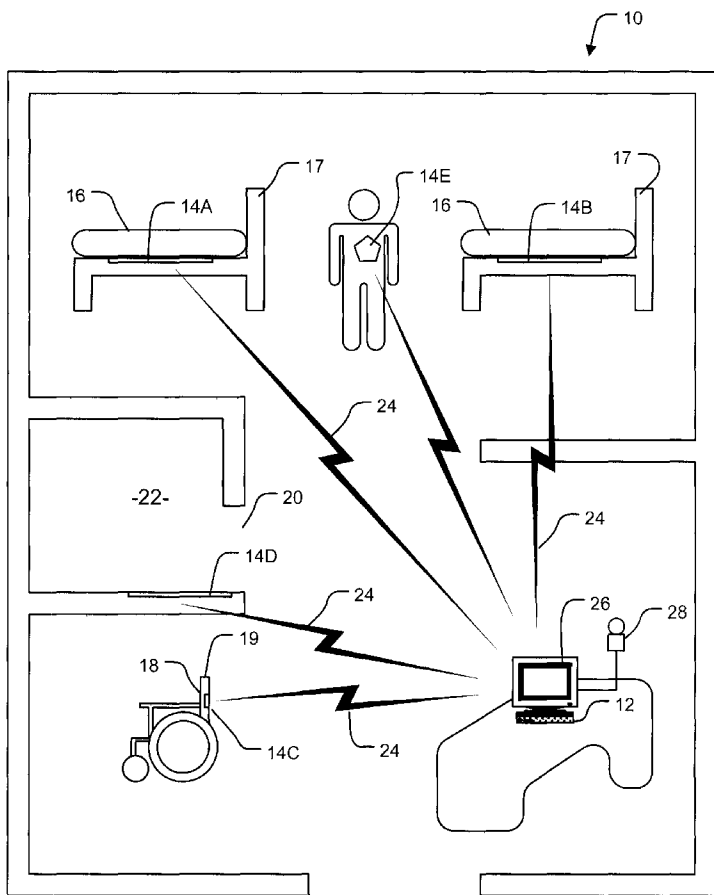

(57) Abstract: Apparatus for monitoring vital signs of one or more living subjects comprises a monitoring station and at least one sensor in communication with the monitoring station. The sensor comprises an antenna system, an ultra wideband radar system coupled to the antenna system, a signal processor and a communication system. The signal processor is connected to receive a signal from the ultra wideband radar system and configured to extract from the signal information about one or more vital signs of a person or animal in a sensing volume corresponding to the antenna system. The communication system is configured to transmit the information to the monitoring station.

WO 2007/101343 A1



SC, SD, SE, SG, SK, SL, SM, SV, SY, TJ, TM, TN, TR,
TT, TZ, UA, UG, US, UZ, VC, VN, ZA, ZM, ZW.

PT, RO, SE, SI, SK, TR), OAPI (BF, BJ, CF, CG, CI, CM,
GA, GN, GQ, GW, ML, MR, NE, SN, TD, TG).

(84) Designated States (*unless otherwise indicated, for every kind of regional protection available*): ARIPO (BW, GH, GM, KE, LS, MW, MZ, NA, SD, SL, SZ, TZ, UG, ZM, ZW), Eurasian (AM, AZ, BY, KG, KZ, MD, RU, TJ, TM), European (AT, BE, BG, CH, CY, CZ, DE, DK, EE, ES, FI, FR, GB, GR, HU, IE, IS, IT, LT, LU, LV, MC, MT, NL, PL,

Published:

— *with international search report*

For two-letter codes and other abbreviations, refer to the "Guidance Notes on Codes and Abbreviations" appearing at the beginning of each regular issue of the PCT Gazette.

ULTRA WIDEBAND MONITORING SYSTEMS AND ANTENNAS

Cross-Reference to Related Applications

5 [0001] This application claims priority under the Paris Convention from United States application No. 60/778,908 filed on 6 March 2006. For purposes of the United States of America, this application claims the benefit of United States application No. 60/778,908, which is hereby incorporated herein by reference, under 35 U.S.C. §119.

Technical Field

10 [0002] The invention relates to apparatus and methods for monitoring for the presence, activity and/or physiological signs of people or animals. The invention may be applied, for example, to monitor one or more of the presence, activity, heart rates and/or breathing rates of patients in a care facility. The invention also relates to antennas for transmitting and/or receiving electromagnetic signals.

15

Background

[0003] Ultra wideband (UWB) electromagnetic signals can be used in a wide range of applications. Such signals typically comprise very short pulses presented at low duty cycles. As such, UWB signals can be advantageous, especially in applications in which it is desirable to maintain low average power levels. UWB radar can be used to measure the locations of objects at short ranges or to obtain images of objects. UWB devices can also be used for wireless communications, particularly for short-range and high rate data transmission.

25 [0004] UWB electromagnetic signals may have frequencies in the range of a few hundred MHz to about 12 GHz. In typical applications, UWB signals are used in the band from 3.1 GHz to 10.6 GHz. In particular UWB devices the frequencies of electromagnetic signals may be limited to particular regions of the spectrum to comply with applicable regulatory requirements. For example, some devices may be made to operate in a sub-band of the UWB spectrum that occupies the UWB spectrum in the range of 3.6 GHz to 30 4.6 GHz. In the United States this sub-band has been allocated by the Federal Communications Commission (FCC) for use by certain UWB devices.

- 2 -

5 [0005] While various UWB devices exist, there remains a need for practical and cost effective solutions for use in UWB systems. For example, there exists a need for practical and cost-effective antennas and antenna systems that can be used to transmit and/or receive UWB signals in various contexts. There is a particular need for such antennas that are compact and provide directional radiation patterns. There is also a need for practical and cost-effective UWB radar transceiver circuits.

10 [0006] Another field in which practical and cost-effective technology is required is the field of monitoring the vital signs of people or animals. For example, it would be beneficial to provide a system capable of monitoring the heart and breathing rates of patients in care facilities and in peoples' homes. While such systems exist, most have various disadvantages. For example, some require that electrodes or other devices be attached to each person being monitored, other systems are prohibitively expensive or insufficiently versatile, other systems are only capable of monitoring one vital sign, such as heart rate.

15 [0007] The prior art includes:

- Newham, US 5,471,198 and Edwards, US 6,788,206 which disclose systems for monitoring for the presence of persons using reflected energy.
- 20 • Richards et al., US 6,900,732 which discloses a system for monitoring assets, objects, persons or animals using UWB signals.
- Richards et al., US 6,466,125 which discloses a system, electronic monitor and method that utilize impulse radio technology to alert medical personnel when a patient needs medical assistance.
- 25 • Richards et al., US 6,504,483 which discloses the use of impulse radio to track a position of a horse as it moves around a race track and/or to enable people to monitor one or more vital signs of the moving horse. The patent discloses that the technology may also work with other animals, such as dogs, and with people.
- Hall et al., US 6,661,342 which discloses the use of impulse radio to track moving athletes and to provide secure communication with athletes.
- 30

- 3 -

- Nowogrodzki et al., US 4,513,748 which discloses a heart rate monitor that utilizes two RF signals.
- Bloice, US 3,796,208 which discloses a system for monitoring movements of a patient using a microwave radar unit.
- 5 • Lye et al, WO 2004/047630 which discloses a system that uses UWB signals to transmit information regarding the health condition of a user.
- Tupin et al. US 2004/0249258 which discloses the use of UWB radar for imaging and acquiring physiological data.
- McEwan, US 5,361,070, which discloses a UWB radar motion sensor.
- 10 • Edwards, US 6,788,206 discloses a patient monitoring system.

Summary of the Invention

[0008] This invention provides apparatus and methods that relate to UWB systems. The apparatus and methods may be applied to systems for monitoring the vital signs of people or animals. The apparatus and methods also have other applications. Such methods and apparatus may incorporate various UWB technology as described herein. Systems according to some aspects of the invention may be implemented using continuous wave (CW) technology.

20 [0009] Some specific aspects of the invention provide antennas and antenna arrays that may be used to send and/or receive UWB signals; UWB radar transceiver circuits; and patient monitoring systems. These specific aspects of the invention may be applied independently of one another and may also be applied in various combinations.

25 [0010] Further aspects of the invention and features of specific embodiments of the invention are described below.

Brief Description of the Drawings

[0011] In drawings which illustrate non-limiting embodiments of the invention,
30 Figure 1 is a block diagram of a patient monitoring system according to an embodiment of the invention;

- 4 -

Figure 2 is a schematic view showing a possible display for the patient monitoring system of Figure 1;

Figure 3 is a block diagram of a sensing unit that could be used in the monitoring system of Figure 1;

5 Figure 4 is a schematic view showing a sensing unit detecting the presence of a person and the person's heart and respiration activity through a mattress by way of radiofrequency pulses;

Figures 4A through 4C illustrate various alternative arrangements of antennas;

Figure 5 is a block diagram of a sensing unit;

10 Figure 6 is a block diagram of an RF radar transceiver that may be used in a sensing unit;

Figure 7 is a timing diagram for parts of the radar transceiver of Figure 6;

Figure 8 is a plan view of an antenna array that may be used to transmit and receive UWB signals;

15 Figure 8A is a plan view of the reverse side of the antenna array of Figure 8;

Figure 8B is an enlarged view of an antenna element of the antenna array of Figure 8; and,

Figures 9, 9A, 9B and 9C are views of a compact antenna that may be used to transmit and/or receive UWB signals.

20

Description

[0012] Throughout the following description, specific details are set forth in order to provide a more thorough understanding of the invention. However, the invention may be practiced without these particulars. In other instances, well known elements have not
25 been shown or described in detail to avoid unnecessarily obscuring the invention. Accordingly, the specification and drawings are to be regarded in an illustrative, rather than a restrictive, sense.

[0013] The following description describes antennas for transmitting and/or receiving
30 ultra wideband signals, circuits for generating ultra wideband signals and systems for monitoring for the presence, activity and/or vital signs of people or animals. The

- 5 -

invention will be described with reference to a patient monitoring system that incorporates all of these elements. However, the various novel components and subsystems described herein also have application in other combinations and contexts.

5 [0014] Figure 1 shows schematically a patient monitoring system 10. System 10 may be used, for example, in a hospital ward, a long term care facility, a nursery, or the like. System 10 has a monitoring station 12 and one or more sensing units 14. In the illustrated embodiment, sensing units 14 include sensing units 14A and 14B that are located under the mattresses 16 of beds 17, a sensing unit 14C that is built into (or mounted on) the
10 backrest 18 of a wheelchair 19, a sensing unit 14D that is mounted at the entrance 20 of a restricted area 22 (restricted area 22 may be, for example, a dispensary in which medications are stored, an exit from the facility, or the like) and a sensing unit 14E that is strapped to a person's chest (as shown) or wrist (not shown).

15 [0015] Monitoring station 12 may receive signals from additional sensors (not shown) in addition to sensors 14. For example, monitoring station 12 may receive signals from door switches, proximity sensors, other patient monitoring devices such as EEG machines, blood oxygen sensors, or the like.

20 [0016] Each sensing unit 14 is in communication with monitoring station 12. The communication is preferably wireless communication. As described below, sensing units 14A, 14B, 14C and 14E monitor for the presence, activity and vital signs of a person at the location of the sensing unit 14. Sensing unit 14D is intended to detect the presence of personnel in restricted area 22. Sensing unit 14D may lack capabilities for detecting
25 vital signs etc. Sensing units 14 may monitor one or more of:

- a heart rate of the person;
- a breathing rate of the person;
- whether a person's breathing or heart beat has stopped;
- whether a person's breathing or heart beat has an abnormal pattern;
- 30 • whether or not the person is active (i.e. moving);

- 6 -

- whether a person is moving in an unusual way (e.g. whether the person is moving in a manner that could indicate a seizure or fit)
- whether or not a person is present in the vicinity of the sensing unit; and,
- the like.

5 Data signals **24** that contain results from the monitoring operation are transmitted to monitoring station **12**.

[0017] Monitoring station **12** comprises a display **26**, a wired or wireless communication module **27** and an alarm **28** which may comprise, for example, a generator of alarm
10 sounds. Communication module **27** receives data signals **24** from sensing units **14**. Monitoring station **12** displays information regarding the various persons being monitored.

[0018] Figure 2 shows an example of a possible display. Monitoring station **12** may, for
15 example, be located at a nursing station where it can be used by a duty nurse to monitor the status of patients. Monitoring station **12** may generate alarms if the data signals meet specified alarm criteria. The alarm criteria may include, for example:

- a person is present but has not moved and has not had a detectable heart beat or respiration for more than a threshold period;
- 20 • a person who should remain present at a sensing unit **14** is no longer detected as being present;
- a person is detected in a restricted area; and,
- the like.

25 [0019] An alarm may cause a visible indicia **29** to be displayed on display **26** (see Figure 2) and may also or in the alternative cause an audible signal to be generated by alarm **28** which may comprise a buzzer or the like. A remote monitoring station (not shown) may be provided in addition to monitoring station **12**. Monitoring station **12** is optionally in
30 communication with a portable monitoring device such as a pager or the like that can signal to a responsible person when an alarm condition is detected at monitoring station **12**.

[0020] Display **26** may display trends in a monitored person's motion as well as any vital signs being monitored as well as values for various vital signs being monitored by system **10**.

5

[0021] Monitoring station **12** may be integrated with an overall patient management system that tracks patient information, treatment history, medication history and the like. Such systems are commercially available and are therefore not described further herein. Personnel at monitoring station **12** can observe the heart and respiration rates of patients being monitored and are warned by an alarm when a patient gets or falls out of bed, a patient stops breathing, a patient's heart stops, a patient is moving abnormally, or there exists some other condition or combination of conditions for which monitoring station **12** provides an alarm.

10

[0022] Sensing units **14** comprise ultra wideband (UWB) radar systems. Figure 3 is a block diagram of an example sensing unit **14**. Sensing unit **14** has a UWB radar system **30** connected to an antenna system **31**. UWB radar system **30** has a UWB transmitter **30A**, and a UWB receiver **30B**. UWB radar system **30** generates UWB pulses that are transmitted by antenna system **31** into a space where a person may be located. This space may be called a "sensing volume" since UWB radar system **30** can be used to detect a person in the space. If a person is present in the space then the pulses are reflected at interfaces within the person's body, such as surfaces of the lungs and heart. Reflected pulses are received at antenna **31** and detected by UWB radar **30**.

20

[0023] In some embodiments, the UWB pulses are in the C-band (3.6 to 4.6 GHz). The width of transmitted UWB pulses may be in the range of 1 ns to 3 ns, for example. UWB pulses are delivered at a suitable rate. The pulse rate may be set to a value low enough that the average emitted power is low enough to satisfy applicable regulatory requirements. For example, the pulse repetition interval (PRI) is in the range of 0.5 μ s to 1 μ s in some embodiments. The time-averaged transmitted output power may be

30

- 8 -

relatively small. For example, the maximum effective isotropic radiation power (EIRP) may be -41.3dBm/MHz or less.

5 [0024] A receiver output signal **32** from UWB radar system **30** is passed to a signal processing system **33**. Signal processing system **33** processes receiver output signal **32** to obtain values for heart rate, breathing rate, and/or other characteristics being monitored by sensing unit **14**. An output signal containing values for the characteristics is passed to wireless communication device **35** which transmits a signal **24** that carries data representing the values to monitoring station **12** by way of antenna **36**. In the illustrated
10 embodiment, a control **38** coordinates the operation of sensing unit **14**. Control **38** may, for example, comprise a programmable microprocessor executing software instructions, logic circuits, or some combination thereof.

15 [0025] Figure 4 illustrates schematically how an antenna system **31** located under a mattress **17** can emit a UWB pulse **40**. Pulse **40** passes into a person **P** and is reflected at various surfaces, including surfaces of the person's lungs **L** and heart **H**, to form reflected pulses **42** that are detected by antenna system **31**. By using UWB radar in a back-scattering remote sensing mode, the system can monitor heart and respiration rates of a person without electrodes or other devices being attached to the body of the person.

20 [0026] Antenna system **31** may comprise an array of transmit antennas **31A** and an array of receive antennas **31B**. The transmit and receive antennas are distributed over an area broad enough to be able to cause and detect reflected pulses **42** from patient **P** in any reasonable position and posture on mattress **16**. Transmit antennas **31A** may be low-gain
25 antennas. The use of low-gain transmit antennas **31A** permits transmission of UWB signals having higher average amplitudes without causing EIRP to exceed thresholds that may be specified by applicable regulations. In some jurisdictions, regulations require that EIRP not exceed a specified threshold value. Further, since low-gain antennas generally have broad radiation patterns the radiation is distributed into a broad angular space.

30

- 9 -

[0027] Receive antennas **31B** may be higher-gain antennas to provide better signal-to-noise ratios (SNR) for received signals containing reflected pulses **42**.

[0028] Figure 4A shows an example arrangement of antenna arrays under mattress **16**.
5 A number of transmitting arrays **31A** and receiving arrays **31B** are arranged in a region **46** extending across mattress **16** at the expected level of the torso of a person **P** lying on mattress **16**. Each transmitting array **31A** is at the center of a cluster of receiving arrays **31B**. In the illustrated embodiment, each transmitting array **31A** is at the center of a group of four receiving arrays **31B** that are approximately equally-spaced from a central
10 transmitting array **31A**. Arranging transmit antennas **31A** and receive antennas **31B** in an interleaved fashion facilitates obtaining a good signal-to-noise ratio. Transmit antennas **31A** may be low-gain antennas that provide a relatively large coverage angle. This permits coverage of region **46** with relatively few transmit antennas **31A**.

15 [0029] Figure 4B shows another possible arrangement in which a number of antenna modules **43** each have a number of transmit antennas **31A** and a number of receive antennas **31B**. Modules **43** may be connected to an electronics module **44** containing a UWB transceiver by suitable waveguides such as coaxial cables **45**. Each module **43** may be, for example, approximately 8 inches square. In the illustrated embodiment, each
20 module **43** has four receiving antennas **31B** and one transmitting antenna **31A**. The antennas may be directly mounted or formed (for example by etching or printing) on a circuit board. Each module may optionally comprise a four-into-one power combiner to collect power from the receive antennas for delivery to electronics module **44**.

25 [0030] The apparatus of Figure 4B may be enclosed within a suitable housing for placement under the mattress of a bed. The housing provides insulation of antennas **31A** and **31B** from contact with any dielectric or metallic surface that could affect their performance. The housing may provide an air gap between antenna modules **43** and an underlying mounting surface. The housing may include a solid base plate to which the
30 antenna modules and electronics module may be mounted. The base plate may, for example, comprise a sheet of aluminum or other suitable material. The housing may

- 10 -

include a radome for environmental protection. The radome may be formed, for example, from a thin layer of plastic. A metallic shielding enclosure may be provided for electronics module **44**.

5 [0031] Figure 4C shows another embodiment which has fewer antennas than the embodiment of Figure 4B. Other arrangements of antennas are also possible.

[0032] In an example embodiment illustrated in Figure 5, UWB transmitter **30A** comprises an oscillator **50** that is quenched to create a pulsed radiofrequency (RF) waveform that passes into a gated amplifier **52** to produce UWB pulses **40**. It is generally desirable that the center frequency of oscillator **50** be tunable to allow for frequency optimization, if required. Any suitable oscillator circuit may be used in oscillator **50**. A wide range of suitable oscillators are known to those skilled in the art. For example, oscillator **50** may comprise an oscillator based on a diode, FET or junction transistor.

15

[0033] In the example embodiment, UWB receiver **30B** receives a signal **53** from receiving array **31B** of antenna system **31** and passes the received signal through a RF signal conditioning stage **54** that comprises, for example, a filter **55** and an amplifier **56**. The conditioned signal is provided to a mixer **58** where it mixes with a signal from oscillator **50** to yield a baseband signal **59**. Baseband signal **59** is further conditioned in baseband conditioning stage **60**, for example, by a filter **61** and amplifier **62**. The conditioned baseband signal is then digitized by analog-to-digital converter (ADC) **64**. ADC **64** is preferably at least a 12/14-bit ADC so that the conditioned baseband signal can be digitized with 80 dB in dynamic range. With an analog anti-aliasing filter of about 20 10Hz, the sampling rate of the ADC does not need to exceed about 50Hz to obtain a digitized signal from which heart rate and respiration rate can be extracted. To reduce the overall cost, size and power consumption of sensing unit **14**, ADC **64** may comprise the ADC part of a combined ADC/microprocessor.

25

30 [0034] In currently preferred embodiments, a coherent Doppler detection scheme is applied to detect reflected pulses **42**. The conditioned baseband signal has a frequency

- 11 -

component that varies with a patient's heart beat and a frequency component that varies as the patient breathes. The conditioned baseband signal may be an audio frequency signal (for example, the conditioned baseband signal may have frequencies in the range of a fraction of a Hertz to a few Hertz).

5

[0035] In the illustrated embodiment, baseband conditioning stage **60** provides separate signal paths for conditioning respiration and heart-rate components of baseband signal **59**. This permits signal conditioning to be optimized for each signal component. Figure 5 shows a filtering stage **61** comprising separate filters **61A** and **61B**, an amplification stage **62** comprising separate amplifiers **62A** and **62B** and a digitization stage **64** comprising separate analog to digital converters **64A** and **64B** that respectively condition a heart-rate signal **65A** and a respiration-rate signal **65B**.

[0036] The digitized signal **65** (having conditioned components **65A** and **65B** in the illustrated example) passes to signal processing stage **33**. Signal processing stage **33** comprises a suitable data processor, such as a digital signal processor or microprocessor, for example, or suitable analog or digital signal processing circuits, such as a suitable configured field-programmable gate array (FPGA). In Figure 5, signal processing stage **33** comprises a digital signal processor (DSP) **66** executing software instructions **68** stored in a program store accessible to DSP **66**. DSP **66** extracts heart rate and respiration rate information from signal **65**.

[0037] In some embodiments, DSP **66** is programmed to perform a transformation of the conditioned baseband signal into the frequency domain. An example of such a transformation is the Fourier transformation, which may be implemented as a fast Fourier transformation (FFT) algorithm. Heart beats in humans typically have frequencies in the range of 0.8 Hz to 3 Hz (50 to 180 beats per minute). Respiration in humans typically occurs at frequencies in the range of 0.1 Hz to 0.7 Hz (6 to 42 breaths per minute). DSP **66** can extract the patient's heart and breathing rates by searching in the transformed frequency domain signal for peaks at frequencies in the ranges expected for heart and

- 12 -

respiration rates. The heart and respiration rate frequency ranges may be specified in DSP software **68** or stored in a data register accessible to DSP **66**.

5 [0038] The heart and respiration rate ranges may be user-configurable. For example, infants may have heart rates that are substantially higher than the heart rates of adults. Where apparatus according to the invention will be used to monitor an infant, the heart and respiration rate frequency ranges may be set to higher values by way of a suitable user interface.

10 [0039] The accuracy of the results may be improved by performing the transformation into the frequency domain for relatively large blocks of data. For example, the transformation into the frequency domain may be performed by taking 3 or more blocks of conditioned baseband data at a time. Each block may contain, for example, 256, 521 or 1024 samples of the conditioned baseband data. Each time a new block is available,
15 the transformation is repeated by dropping the oldest block and adding the newest block. The data on which each successive transformation is based therefore overlaps with the data for the immediately prior transformation. For example, where 4 blocks of data are taken at a time, there is a 75% overlap in the data used for each transformation.

20 [0040] Further enhancement may be made by using a previously- determined average heart rate to assist in identifying the heart rate signal in cases where there are multiple peaks in the frequency spectrum within the frequency-range corresponding to expected heart rates. In cases where DSP **66** identifies more than one peak in the frequency domain data that could be a heart rate, DSP **66** may be programmed to select the peak that is
25 closest to the previously-determined average heart rate.

[0041] Harmonics of the respiration frequency can fall in the heart rate frequency range. Receiver **30B** may be designed to minimize such harmonics. In some embodiments, DSP **66** may be programmed to detect frequency components that are harmonics of the heart
30 rate or respiration rate and to determine the heart rate or respiration rate entirely, or in part from the frequencies of the harmonics. For example, the heart rate may be

- 13 -

determined by detecting and measuring the frequency of the second harmonic of the heart rate and dividing the result by two.

5 [0042] In some cases, a person can have a respiration rate that is relatively high and a heart rate that is relatively low. In such cases, it may not be possible to separate the heart rate and respiration rate signals (especially because the signal level of the respiration rate signal is typically much larger than that of the heart rate signal - in some cases the respiration rate signal may be 20 dB to 30 dB higher in amplitude than the heart rate signal). This amplitude difference can be reduced somewhat by providing a filter that
10 reduces the amplitude of the respiration signal in signal conditioning stage 60. For example, signal conditioning stage 60 may reduce the amplitude of signals in the respiration frequency range by 10 to 15 dB relative to signals in the heart rate frequency range.

15 [0043] Identification and measurement of the frequencies of respiration and heart beat signals may be enhanced by performing time-domain analysis of the conditioned baseband signal. For example, one can measure the respiration rate by counting peaks and zero-crossings in the conditioned baseband signal (which may be further conditioned by suitable filtering). By filtering out lower frequencies in the conditioned baseband signal
20 one may also measure heart rate by counting peaks in the signal resulting from heart motion. Respiration rate information and/or heart rate information obtained by time domain analysis may be combined with corresponding information obtained by frequency domain analysis to obtain refined estimates of respiration rate and/or heart rate. In the alternative, respiration rate information and/or heart rate information may be obtained by
25 time domain analysis instead of by frequency domain analysis.

[0044] In some embodiments, respiration rate and heart rate may be determined in two or more different ways and a value for the respiration rate or heart rate may be established by combining results obtained in the two or more different ways. For example, a system
30 according to the invention may include a first means for determining the heart rate by directly identifying a frequency component corresponding to the heart rate in the Fourier

- 14 -

transform of the conditioned baseband signal; a second means for determining the heart rate by identifying a frequency component corresponding to the second harmonic of the heart rate in the Fourier transform of the conditioned baseband signal; a third means for determining the heart rate by time-domain analysis of the conditioned baseband signal; and a combining means for combining results provided by the first, second and third means to yield a value for the heart rate. The combining means may, for example, take an average or a weighted average of the results.

[0045] DSP 66 averages the heart and respiration rates over suitable windows and provides updated averages to communication subsystem 35. For example, both the heart rate and respiration rate may be averaged over a window of 15 to 30 seconds. Since the respiration rate is typically less than the heart rate, respiration rate may optionally be averaged over a longer window. Shorter averaging times may be used initially to reduce the time between power up and the availability of heart rate and respiration rate information.

[0046] Heart rate and respiration rate are updated at a frequency which is sufficient to provide timely results. For example, heart rate may be updated every few seconds (e.g. every 1 to 5 seconds). If desired, respiration rate may be updated at a lower frequency (e.g. every 5 to 15 seconds).

[0047] When a patient moves, the motion causes large amplitude low-frequency components in the conditioned baseband signal. These low-frequency components can overwhelm the heart rate signal, the breathing rate signal, or both of these signals. For the duration of such motion it may be difficult to identify the heart rate signal or the breathing rate signal or both of these signals. DSP 66 is preferably programmed to detect such motion artifacts and to generate a signal (for example, by setting a motion-sensing flag) which indicates to monitoring station 12 that motion is detected and the motion is preventing the update of respiration rate and/or heart rate. DSP 66 may detect motion artifacts by identifying large amplitude low-frequency components in the conditioned baseband signal 65.

- 15 -

[0048] Communication subsystem 35 transmits the updated averages and any additional information, such as a motion flag, and an ID code that identifies the sensing unit 14 to monitoring station 12. Any suitable communication technologies and protocols may be provided to transmit data from sensing unit 14 to monitoring station 12. Some non-limiting examples are: a wired or wireless local area network (LAN) such as an ethernet LAN, an IEEE 802.11 network, or a wireless data communication system compliant with the ZigBee™ specification. Note that some processing may be performed at monitoring station 12 instead of at signal processing stage 33.

10

[0049] Heart rates do not typically change suddenly in comparison to the period of the heart rate. Monitoring station 12 (or DSP 66) may perform statistical analysis on the averaged heart rate and breathing rate values. For example, a new heart rate value may be compared to the previous average heart rate value. If the new heart rate value differs by more than a threshold amount (for example, 50%) from the previous average heart rate value then monitoring station 12 (or DSP 66) may be configured not to display the new value. In this situation, monitoring station 12 may indicate that the heart rate value is unreliable by displaying a symbol, instead of or in addition to the heart rate value, not displaying the heart rate value, displaying the heart rate value using different display parameters (e.g. flashing, a different color, etc.) or the like.

20

[0050] Monitoring station 12 may monitor heart rate and breathing rate signals for patterns that indicate a potential problem. For example, monitoring station 12 may be configured to trigger an alarm if a person's respiration rate suddenly increases and stays high, either on its own or in combination with other factors.

25

[0051] Figure 6 shows a circuit 70 that may be used as UWB radar 30. Circuit 70 has a signal generation section 70A and a signal receiving section 70B. Signal generation section 70A produces a local oscillator signal 71 and a UWB pulse signal 72. Signals 71 and 72 have different waveforms. Signal 72 is made up of short UWB pulses having pulse-width of a few nanoseconds (ns).

30

- 16 -

[0052] Local oscillator signal **71** provides pulses that are longer than the pulses in signal **72** with the same carrier frequency as the pulses in signal **72**. The length of pulses in local oscillator signal **71** should be sufficiently long to allow capture of all reflected pulses **42** in a range of interest. Reflected pulses **42** which arrive after the end of the local oscillator pulse will not be detected. It is desirable to keep pulses in local oscillator signal **71** short to exclude unwanted signals from the surroundings and to avoid unnecessary RF coupling. For example, the length of pulses in signal **71** is typically in the range of about 5 ns to 10ns or so and may be adjustable. In some embodiments the pulses in signals **71** and **72** can be of the same or similar lengths.

[0053] In signal generation section **70A**, a clock **74** operates to provide a clock signal at a desired pulse repetition frequency, for example, about 1 MHz to long-pulse gating circuit **76**. Long-pulse gating circuit **76** generates pulses that cause quenching circuit **78** to quench oscillator **78** which operates at a suitable frequency (e.g. a C-band frequency). Local oscillator signal **71** is taken off at signal splitter **80**.

[0054] After a time delay set by delay circuit **84**, a short pulse is generated by SP gating circuit **86**. The short pulse operates switch **82** to pass a very short RF pulse to the transmitting antenna array via filter **88**. Keeping transmitted pulses short implies that the transmitted pulses will have a relatively broad bandwidth with low average signal level. Such low level signals can be made to meet regulatory requirements, such as requirements imposed by the Federal Communications Commission (FCC) in the United States which limit the allowable time-averaged and maximum signal levels. Delay **84** allows control over the relative timing between the transmit pulses in signal **72** and local oscillator signal **71**.

[0055] Receiving section **70B** receives a signal from a receiving antenna array. The signal is filtered at filter **90** and amplified by a low noise amplifier **92** before it is mixed with local oscillator signal **71** at mixer **94**. An attenuator **73** may be provided to reduce the amplitude of local oscillator signal **71** upstream of mixer **94**. A baseband signal

- 17 -

output from mixer **94** is filtered at filter **95**, adjusted for offset at differential amplifier **96A**, amplified at amplifier **98A** and filtered at filter **99A**.

[0056] In the illustrated embodiment, differential amplifier **96A**, amplifier **98A** and filter
5 **99A** carry a signal from which heart-rate will be determined. A separate differential
amplifier **96B**, amplifier **98B** and filter **99B** are provided to condition a signal from
which respiration rate will be determined. This facilitates separation of the heart-rate and
respiration signals. The component of the demodulated signal at the output of mixer **94**
10 that carries information regarding respiration is typically about 20 dB to 30 dB higher in
magnitude than the component of the signal that represents heart rate. A high pass filter
99A in the heart rate channel can filter out much of the respiration signals. The high-pass
filter may, for example, filter out signal components that have frequencies less than about
0.5 Hz and pass higher-frequency signals. Separation of the respiration signal from the
heart-rate signal allows amplification of the respiration and heart rate signals to levels
15 which facilitate time-domain signal processing of the signals.

[0057] Receiving section **70B** provides separate outputs which carry signals from which
reflected power and motion of a person can be detected. Motion detection output **102**
receives a signal that is amplified by amplifier **100** and filtered by a high-pass filter **101**.
20 If the signal at motion detection output **102** has a value exceeding a threshold then this
is an indication that the patient is moving enough to disrupt heart rate or breathing rate
measurements.

[0058] Amplifier **104** and filter **105** respectively amplify and low-pass filter a signal
25 taken at the output of mixer **94**. This signal is presented at output **106**. The amplitude of
the signal at output **106** increases as the reflected power picked up by receive antennas
31B increases.

[0059] Reflected power may be measured by an envelope detector. The amplitude of
30 reflected power will, in general, depend upon the configuration of the apparatus, the
nature of the subject, the posture and location of the subject, and the like. In some

- 18 -

embodiments, the presence or absence of a subject is determined by comparing reflected power received at two different sets of antennas (typically the two sets of antennas are two antenna arrays). The difference in the reflected power received at two arrays can be compared to a threshold to determine whether or not a subject is present. In such
5 embodiments, amplifier 104 may comprise a difference amplifier, as shown in Figure 6. An advantage of this construction is that it requires little or no adjustment to compensate for variability in the apparatus.

[0060] Where no person (or other person-like object) is present within the sensing
10 volume then the signal at output 106 will have an amplitude within a given range. In the case of a bed sensor, this indicates that the bed is not occupied. In the case of sensors being used in other applications, this indicates that a person is not present within the sensing volume. When a person enters the sensing volume then the reflected power (or reflected power difference) indicated by the signal at output 106 changes. A system 10
15 may monitor the signal at output 106 and change a status flag from, for example, NOT_OCCUPIED to NORMAL when the signal at output 106 changes to a value outside of the range that it has when no person is present.

[0061] Circuit 70 may perform a calibration routine which sets the range of values
20 corresponding to the bed being unoccupied when it is powered-up, or at other times when the bed is unoccupied in response to a user input.

[0062] A signal processing system 33 may set a status flag based on the combination of
25 signals at outputs 102 and 106. The status flag may, for example, have values of NOT OCCUPIED, MOTION, and NORMAL. Some embodiments may have status flags for both normal motion and abnormal motion. The status flag indicating normal motion may be set when a person being monitored rolls over or changes position in a way that is normal and expected. The status flag indicating abnormal motion may be set when the person being monitored makes movements that indicate a possible problem that may
30 require intervention. For example, the status flag indicating abnormal motion may be set when the person being monitored makes continued thrashing movements as may

- 19 -

accompany certain types of seizure. Updating of heart rate and respiration rate values may be suppressed when the status flag has a value other than "NORMAL".

[0063] Figure 7 is a timing diagram that illustrates the relative timing between shorter pulse gating signal **87** which controls the timing and lengths of transmitted UWB pulses in signal **72** and longer pulse signal **77** which controls the timing and duration of pulses in local oscillator signal **71**. Signal **77** has pulses of length **A**, for example 5-10 ns separated by intervals of length **B**, for example, about 1 μ s. In the illustrated embodiment, pulses in signal **87** begin at time **C**, typically a few ns, after the initiation of the longer pulse in signal **77**. This promotes frequency and phase stability at the start of the oscillation. The pulses in signal **87** have lengths **D**, of a few ns (for example, 1-5 ns and preferably 3 ns or less, for example 1-2 ns). The pulse length **D** and pulse repetition rate may be chosen to achieve a time-averaged power density that is low enough to comply with limits imposed by applicable regulations.

15

[0064] Received signals **89** will arrive at receiver **70B** in different time slots. The pulse length **A** during which local oscillator signal **71** is available is sufficiently long to encompass all received signals **89**. The received signal is time gated at receiver **70B** by the local oscillator signal. Using a local oscillator signal that is longer than the transmitted signal allows the simultaneous detection of signals from all receive antennas. As a result, channel multiplexing is not required. The local oscillator signal should not be unnecessarily long in order to prevent receiver **70B** from receiving unwanted noise signals. In some embodiments, a blanking signal **MP** is generated at the start of each transmit pulse **SP**. Blanking signal **MP** is connected to suppress the reception of received signals **89** while UWB pulses are being transmitted. This prevents signals induced in the receive antennas by near-field coupling to the transmit antenna(s) from being mistaken for desired received signals **89**.

[0065] The basic technology described above may be applied to systems that monitor a single person. For example, a sensing unit **14** may be provided to monitor for the presence, respiration rate and/or breathing rate of an infant in a crib or of a person in a

30

- 20 -

bed or chair. An alarm may be integrated with sensing unit **14** or the sensing unit **14** may be connected to communicate an alarm signal to a remote alarm unit (either by way of a wired or wireless connection). In one embodiment, a sensing unit **14** is combined with a baby monitor. A base station of the baby monitor receives sounds made by an infant and also delivers an alarm signal in case the output from sensor **14** indicates a possible problem (such as the infant has stopped breathing). In another embodiment, a sensor **14** is connected directly to an alarm and operates the alarm if the sensor **14** detects that a person being monitored has stopped breathing for more than a short time. Such a system may be used with or without external monitoring to wake up a person who suffers from sleep apnea by triggering the alarm.

[0066] Figures 8, 8A and 8B show a design for an antenna array **120** that may be used in a system of the type described herein and may also be used for other applications. Individual antennas of the type shown in Figure 8B may be combined into arrays of other types or used in stand-alone applications. Array **120** comprises a plurality of dipole-like antennas disposed on a planar substrate **121** such as a circuit board. Substrate **121** may comprise a two-sided copper-clad laminate in which the copper cladding has been patterned as shown in Figure 8.

[0067] In Figure 8, electrically conducting regions on a first side of substrate **121** are shown in solid outline while electrically conducting regions on a second side of substrate **121** are shown in dotted outline. Figure 8A shows the pattern of electrically-conducting regions on the second side of substrate **121**.

[0068] In the illustrated embodiment, twelve receive antennas **122** are interconnected by waveguides **123**. Receive antennas **122** are located at nodes of a rectangular grid. Two-way signal combiners **126** combine signals from all of receive antennas **122** into a single output **128**. A transmit antenna **130** is located in the centre of array **120**. When array **120** is positioned at a proper height above a ground plane, both transmit antennas **120** and receive antennas **130** have directional radiation patterns.

- 21 -

[0069] Each antenna **122** and **130** has elements **124A** and **124B** that extend in opposite directions on opposite faces of substrate **121**. A single antenna **122** is shown in detail in Figure 8B. Elements **124A** and **124B** are mirror images of one another and are each symmetrical about a centre line **131**. Each element **124A** has a rounded segment **132** in the vicinity of its feed point **133** and a number of stubs of unequal length on its open end. In the illustrated embodiment, in each element **124**, rounded segment **132** merges into straight diverging edge segments **134** which extend to corners **136** of outer stubs **137**. The open end of the element **124** is W-shaped. Straight segments **138** form acute angles at corners **136**. A central stub **140** is defined between substantially straight segments **142** which meet at a corner **144**. In the illustrated embodiment, corner **144** is approximately a right angle.

[0070] The resonant frequencies of antenna **122** or **130** are determined primarily by the effective length of elements **124** in the Z-direction (i.e. in a direction parallel to line **131**). Broad frequency bandwidth is achieved by providing a curved geometry near feed point **133** and multiple (three in the illustrated example) stubs of different lengths at the open end of the element. This geometry allows resonances at multiple frequencies due to its varying effective element length. In some embodiments, over 30% of frequency bandwidth can be achieved with or without use of a reflective ground plane.

[0071] The bandwidth of each antenna **122** or **130** can be adjusted by varying the subtended angle, θ (see Figure 8) between segments **134**. In general, the bandwidth increases as the subtended angle is increased and decreases as the subtended angle is decreased. By selecting an appropriate subtended angle θ in an antenna used to transmit a signal, the frequency spectrum of transmitted radiation can be adjusted. By selecting an appropriate subtended angle θ in an antenna used to detect signals, unwanted signals may be filtered from the received signal.

[0072] The input impedance of radiating elements **124** is matched to a 50 ohm unbalanced microstrip transmission line **123** through a pair of balanced strip lines **150** of constant width. By selecting an appropriate length for balanced strip line **150** and by

- 22 -

selecting appropriate dimensions for the feed point **133** of the antenna **122** or **130**, the antenna **122** or **130** can be matched to a 50 ohm unbalanced transmission line without any additional matching network.

5 [0073] Antenna array **120** has the advantages that can be made with standard circuit board manufacturing techniques and provides a compact balanced dipole structure suitable for transmitting and receiving UWB pulses.

[0074] As noted above, UWB radar may be used to detect the presence, movement, heart
10 and respiration rates of a person sitting in a chair. A sensing unit for use on a chair back, as a sensor to be strapped-onto a person's chest or back, as a sensor to be used in conjunction with a baby crib, or in similar applications does not need to cover a field as large as a sensing unit for use in a full-sized bed. Consequently, a sensing unit for such an application may be made to have fewer antennas than would be required to cover a
15 full-sized bed. For example, a sensing unit for sensing the presence, heart rate, and/or respiration rate of an infant in a small crib does not need to cover a large field and may have only one antenna or just a few antennas.

[0075] Figures 9, 9A, 9B and 9C show a compact antenna **170**. Antenna **170** comprises
20 a radiating element **172** that can be mounted directly to a circuit board, for example, by soldering, attachment using an electrically-conductive adhesive, or the like. Antenna **170** may be used in a sensing unit as described herein or may be used in other applications.

[0076] Antenna **170** has a three-dimensional configuration. Radiating element **172** is
25 mounted above an electrically-conducting ground plane **174**. Ground plane **174** may comprise a layer of metal on a printed circuit board substrate, for example. Radiating element **172** may be formed by stamping a thin metal sheet, for example.

[0077] In some embodiments, an electronics module containing UWB radar comprises
30 a circuit board to which a radiating element **172** can be attached to provide an antenna **170**. The circuit board may also comprise locations to which waveguides can connect

- 23 -

external antennas or antenna arrays. Depending upon the application, a radiating element **172** or one or more external antennas or antenna arrays may be connected to the circuit board. This permits the same circuit board to be used in sensing units of various types. For example, a number of antenna arrays can be connected to the circuit board for use as
5 an in-bed sensor while a radiating element **172** can be connected to the circuit board for use as a sensor in a chair back, under the mattress of a baby crib, or the like.

[0078] Antenna **170** radiates linearly polarized E-fields through the narrow gaps **178** between the radiating element and the ground plane **174**. The resonant frequencies of the
10 antenna are primarily determined by the overall dimensions of antenna **170** in the X and Z directions. A small stub **180** extended above the open end **182** of radiating element **172** can be provided to fine tune the resonant frequencies of antenna **170**. The characteristics of antenna **170** may also be altered by providing a dielectric material between radiating element **172** and ground plane **174**.

15

[0079] The geometry and dimension of antenna **170** in the Y direction determines the frequency bandwidth of antenna **170**. Triangular shapes **184** of the geometry at both sides of antenna **170** allow for broadband frequency of operation. Over 20% of frequency bandwidth can be achieved with a proper shaping. Some embodiments of antenna **170**
20 have a cardioid radiation pattern with directivity between 6 dBi to 8 dBi, depending on the size of ground plane **174**.

[0080] An input feed point **188** is recessed into antenna **170**. By selecting an appropriate distance of feed point **188** from edge **190**, antenna **170** can be directly matched to a 50
25 ohm transmission line without an additional matching network.

[0081] For UWB operation, antenna **170** may have a radiating gap **178** of about 1 mm and a distance between the top of the radiating element **172** and ground plane **174** in the range of about 5mm to 6mm.
30

[0082] It can be appreciated that the invention has several aspects including:

- 24 -

- antennas having features of antennas like those in Figures 8, 8A and 8B that may be applied for any purpose;
- antennas having features of an antenna like the one shown in Figures 9, 9A and 9B that may be applied for any purpose;
- 5 • monitoring systems that may be used for monitoring the presence, heart rate and/or respiration rate of one or more persons of which the system of Figure 1 is an example;
- monitoring systems that may be used to monitor the well being of an infant or single person - examples of such systems include baby monitors and systems for
10 waking a person who suffers from sleep apnea if the person stops breathing for more than a short time; and,
- sensors based on UWB radar that may be used to monitor for the presence, heart rate and/or respiration rate of a person. Such sensors may be used, for example, by emergency personnel (e.g. firefighters, ambulance attendants, emergency
15 response technicians, military medics or the like) to test for the presence of vital signs in injured or unwell people. Such sensors may be portable. In some embodiments the sensors are configured to be pressed against the back or chest of a person and include a display or other indicator that identifies whether or not vital signs (e.g. heart beat and/or breathing) can be detected and may provide
20 information such as heart rate and breathing rate.
- sensors based on UWB radar that may be used to detect a pulse at a location on an individual. Such sensors may be used, for example, in non-invasive blood pressure monitors which compute blood pressure of an individual based upon the speed of propagation of pulses in the individual's circulatory system. Such
25 sensors may be provided, for example, at a person's neck and ankle. The difference in the time at which a pulse is detected at these two locations may be correlated to the individual's blood pressure. Two such sensors may be connected to a controller that determines a difference in time between the arrival of pulses at the sensors and computes a blood pressure or a change in a blood pressure
30 based at least in part on that time difference.

- 25 -

[0083] Certain implementations of the invention comprise computer processors which execute software instructions which cause the processors to perform a method of the invention. For example, one or more processors in a sensing unit or a combination of processors in sensing units and a monitoring station may implement the methods for
5 obtaining heart rate and breathing rate information that are described herein by executing software instructions in a program memory accessible to the processors. The invention may also be provided in the form of a program product. The program product may comprise any medium which carries a set of computer-readable signals comprising instructions which, when executed by a data processor, cause the data processor to
10 execute a method of the invention. Program products according to the invention may be in any of a wide variety of forms. The program product may comprise, for example, physical media such as magnetic data storage media including floppy diskettes, hard disk drives, optical data storage media including CD ROMs, DVDs, electronic data storage media including ROMs, flash RAM, or the like. The computer-readable signals on the
15 program product may optionally be compressed or encrypted.

[0084] Where a component (e.g. a software module, processor, assembly, device, circuit, etc.) is referred to above, unless otherwise indicated, reference to that component (including a reference to a "means") should be interpreted as including, as equivalents of
20 that component, any component which performs the function of the described component (i.e., that is functionally equivalent), including components which are not structurally equivalent to the disclosed structure which performs the function in the illustrated exemplary embodiments of the invention.

[0085] As will be apparent to those skilled in the art in the light of the foregoing disclosure, many alterations and modifications are possible in the practice of this invention without departing from the spirit or scope thereof. For example:

- In some embodiments transmit pulses are distributed among several transmit antennas such that the transmit antennas transmit UWB pulses in different time
30 slots. In each of the time slots reflected pulses may be detected at a plurality of receive antennas. In some embodiments, this is achieved by distributing transmit

- 26 -

signals to each of several antennas which are placed at various locations and are separated from the UWB transmitter by different RF path lengths.

- In some of the implementations described above, a switched amplifier is used for RF switch **82**. However, a suitable RF switch can also be implemented using other technologies such as PIN diodes, Schottky Diodes, micro-electro-mechanical (MEM) switches and the like.
- Some embodiments which are designed for short range lack a switch **82**.

Accordingly, the scope of the invention is to be construed in accordance with the substance defined by the following claims.

10

- 27 -

What is Claimed is:

1. Apparatus for monitoring vital signs of one or more living subjects, the apparatus comprising:
 - 5 a monitoring station;
at least one sensor in communication with the monitoring station, the sensor comprising:
 - an antenna system;
 - an ultra wideband radar system coupled to the antenna system;
 - 10 a signal processor connected to receive a signal from the ultra wideband radar system and configured to extract from the signal information about one or more vital signs of a person or animal in a sensing volume corresponding to the antenna system; and
 - 15 a communication system configured to transmit the information to the monitoring station.
2. Apparatus according to claim 1 comprising a mattress wherein the antenna system is located below an upper surface of the mattress.
- 20 3. Apparatus according to claim 1 comprising a mattress wherein the antenna system is located under the mattress.
4. Apparatus according to claim 3 wherein the antenna system is covered by a radome that is substantially transparent to ultra wideband radiation wherein the
25 radome is located under the mattress.
5. Apparatus according to claim 4 comprising a metallic mounting surface underlying the antenna system wherein the antenna system is spaced apart from the mounting surface by an air gap.

30

- 28 -

6. Apparatus according to any one of claims 2 to 5 wherein the antenna system comprises an array of antennas extending across the mattress in a band at a location between head and foot ends of the mattress.
- 5 7. Apparatus according to any one of claims 1 to 6 wherein:
the antenna system comprises a plurality of groups of antennas,
a group of antennas comprising at least one transmit antenna connected to transmit ultra wideband pulses generated by the ultra wideband radar system and a plurality of receive antennas connected to receive ultra wideband pulses
10 reflected by the person or animal;
wherein the plurality of receive antennas are approximately equally spaced from the transmit antenna.
8. Apparatus according to claim 7 wherein the transmit antenna and the plurality of receive antennas are disposed on a substantially planar substrate.
15
9. Apparatus according to any one of claims 1 to 4 wherein the antenna system comprises at least one transmit antenna connected to transmit ultra wideband pulses generated by the ultra wideband radar system and a receive antenna connected to receive ultra wideband pulses reflected by the person or animal.
20
10. Apparatus according to claim 9 wherein the transmit antenna has a lower gain than the receive antenna.
- 25 11. Apparatus according to any one of claims 1 to 5 wherein the antenna system comprises an array of antennas disposed on a substantially planar member.
12. Apparatus according to any one of claims 1 to 5 wherein the antenna system comprises an array of receive antennas and at least one transmit antenna disposed
30 on a substantially planar member.

- 29 -

13. Apparatus according to any one of the claims 1 to 12 wherein the radar system comprises a transmitter configured to generate pulses having durations of 3 ns or less and a receiver gated by pulses having lengths in excess of 5 ns.
- 5 14. Apparatus according to any one of claims 1 to 12 wherein the signal processor comprises a data processor executing instructions that cause the data processor to transform the signal into the frequency domain and to identify a peak in the transformed signal lying within a band of frequencies characteristic of heart rates.
- 10 15. Apparatus according to claim 13 wherein the instructions cause the data processor to search for a peak in a frequency range that is based at least in part upon a previously-determined heart rate.
- 15 16. Apparatus according to claim 13 wherein, if the data processor identifies a plurality of peaks in the band of frequencies, the instructions cause the data processor to select one of the plurality of peaks that is closest to a previously-determined heart rate.
- 20 17. Apparatus according to any one of claims 1 to 13 wherein the signal processor comprises a data processor executing instructions that cause the data processor to transform the signal into the frequency domain and to identify a peak lying within a band of frequencies characteristic of breathing rates.
- 25 18. Apparatus according to any one of claims 13 to 16 wherein the data processor is configured to detect in the signal motion artefacts and to generate a motion-sensed signal indicating that the person or animal is moving.
- 30 19. Apparatus according to claim 17 wherein the monitoring station is configured to temporarily suppress display of updated information regarding a vital sign in response to the motion-sensed signal.

- 30 -

20. Apparatus according to any one of claims 1 to 18 wherein the radar system comprises a reflected power output and the signal processor is configured to monitor a reflected power signal at the reflected power output and to generate an occupancy signal based at least in part upon the reflected power signal.
- 5
21. Apparatus according to claim 19 comprising an amplifier and a low-pass filter wherein the reflected power signal is a signal that has been amplified by the amplifier and filtered by the low-pass filter.
- 10
22. Apparatus according to any one of claims 1 to 18 wherein the radar system comprises first and second reflected power outputs that carry first and second reflected power signals and the signal processor is configured to monitor a difference between the first and second reflected power signals and to generate an occupancy signal based at least in part upon the difference.
- 15
23. Apparatus according to any one of claims 1 to 21 wherein the antenna system comprises at least one antenna that comprises a first element on a first side of a generally planar substrate and a second element on a second side of the substrate opposed to the first side, wherein each of the first and second elements are
- 20
- symmetrical about a centre line.
24. Apparatus according to claim 22 wherein each of the elements comprises a plurality of stubs.
- 25
25. Apparatus according to claim 23 wherein the stubs are pointed.
26. Apparatus according to claim 23 or 24 wherein the stubs are of different lengths.
27. Apparatus according to any one of claims 23 to 25 wherein the stubs include a
- 30
- central stub having edges that follow intersecting straight lines.

- 31 -

28. Apparatus according to claim 26 wherein the straight lines intersect at an angle of 90 ± 5 degrees.
- 5 29. Apparatus according to any one of claims 23 to 27 wherein each element has a feed connection to a transmission line and a first segment of the edge of the element is rounded in a vicinity of the feed connection.
- 10 30. Apparatus according to claim 28 wherein the first segment merges into diverging straight segments which extend to corners of outer ones of the stubs.
31. Apparatus according to any one of claims 23 to 29 wherein the stubs of the elements extend away from the centre line.
- 15 32. Apparatus according to any one of claims 23 to 30 wherein each of the elements has three stubs.
33. Apparatus according to any one of claims 23 to 31 wherein each of the stubs extends to a pointed corner at which segments of an edge of the element intersect.
- 20 34. Apparatus according to any one of claims 22 to 32 wherein the antenna is matched directly to a 50 ohm unbalanced transmission line.
- 25 35. Apparatus according to any one of claims 1 to 21 wherein the antenna system comprises at least one antenna that comprises a three-dimensional radiating element mounted directly to a circuit board over a ground plane on the circuit board, wherein the radiating element comprises an open end and a stub extended over the open end.
- 30 36. Apparatus according to claim 34 comprising an input feed point recessed from an edge of the radiating element.

- 32 -

37. Apparatus according to claim 35 wherein the stub and input feed point are at opposed ends of the radiating element.
38. Apparatus according to one of claims 34 to 36 wherein the radiating element
5 tapers in width toward the open end.
39. Apparatus according to one of claims 34 to 37 wherein the radiating element comprises skirt portions that extend toward the ground plane along lateral edges of the radiating element.
10
40. Apparatus according to any one of claims 1 to 38 wherein the monitoring station comprises a display and is configured to display on the display a heart rate detected by the sensor.
- 15 41. Apparatus according to claim 39 wherein the heart rate is measured in beats per minute.
42. Apparatus according to any one of claims 1 to 38 wherein the monitoring station comprises a display and is configured to display on the display a breathing rate
20 detected by the sensor.
43. Apparatus according to claim 41 wherein the breathing rate is measured in breaths per minute.
- 25 44. Apparatus according to any one of claims 1 to 38 wherein the monitoring station comprises a display and is configured to display on the display indicia indicating whether or not the sensor detects a living subject.
- 30 45. Apparatus according to any one of claims 1 to 38 wherein the monitoring station comprises a display and is configured to display on the display indicia indicating whether or not the sensor detects that a living subject is moving.

- 33 -

- 5 46. Apparatus according to claim 44 comprising means for monitoring a motion signal indicative of motions of a living subject and, based at least in part upon an amplitude or duration of the motion signal, determining that the motions of the living subject are not normal wherein the monitoring station is configured to display on the display indicia indicating that the motions of the living subject are not normal.
- 10 47. Apparatus according to any one of claims 1 to 45 wherein the at least one sensor comprises a chair sensor, the chair sensor mounted on or built into a backrest of a chair.
- 15 48. Apparatus according to any one of claims 1 to 46 wherein the at least one sensor and the monitoring station each comprises a wireless data transceiver and the information is transmitted from the at least one sensor to the monitoring station wirelessly by way of the wireless data transceivers.
- 20 50. Apparatus according to claim 48 wherein the frequencies are in the range of about 3.6 GHz to about 4.6 GHz.
- 25 51. Apparatus according to claim 48 wherein the frequencies are in a band at about 6 GHz.
52. Apparatus according to any one of claims 1 to 50 wherein the ultra wideband radar system transmits pulses with a pulse repetition interval in the range of about 0.5 μ s to about 1 μ s.
- 30 53. Apparatus according to any one of claims 1 to 51 wherein the ultra wideband radar system comprises:

- 34 -

- an oscillator;
- a mixer connected to receive inputs from the oscillator and from reflected signals detected by the antenna system to produce a baseband signal at an output of the mixer; and,
- 5 an analog-to-digital converter connected to digitize the baseband signal.
54. Apparatus according to claim 52 comprising an amplifier and a filter in a signal path between the antenna system and the mixer.
- 10 55. Apparatus according to any one of claims 1 to 52 wherein the monitoring station comprises an audible alarm and the monitoring station is configured to sound the audible alarm in response to detecting that a subject being monitored has ceased breathing for more than a threshold time.
- 15 56. Apparatus according to any one of claims 1 to 52 wherein the monitoring station comprises an audible alarm and the monitoring station is configured to sound the audible alarm in response to detecting that a breathing rate of a subject being monitored is outside of a preset range.
- 20 57. Apparatus according to any one of claims 1 to 52 wherein the monitoring station comprises an audible alarm and the monitoring station is configured to sound the audible alarm in response to detecting that heart activity of a subject being monitored has ceased for more than a threshold time.
- 25 58. Apparatus according to any one of claims 1 to 52 wherein the monitoring station comprises an audible alarm and the monitoring station is configured to sound the audible alarm in response to detecting that a heart rate of a subject being monitored is outside of a preset range.
- 30 59. Apparatus according to any one of claims 1 to 52 wherein the monitoring station comprises an audible alarm and the monitoring station is configured to sound the

- 35 -

audible alarm in response to detecting that a subject being monitored is not present for more than a threshold time.

- 5 60. Apparatus according to claim 58 wherein the ultra wideband radar system is situated to detect presence of the person being monitored in a bed or chair.
- 10 61. Apparatus according to any one of claims 1 to 52 wherein the monitoring station comprises an audible alarm and the monitoring station is configured to sound the audible alarm in response to detecting abnormal motions of a subject being monitored.
62. An antenna having features, combinations of features or sub-combinations of features as disclosed herein with reference to Figures 8, 8A and 8B.
- 15 63. An antenna having features, combinations of features or sub-combinations of features as disclosed herein with reference to Figures 9, 9A, 9B and 9C.

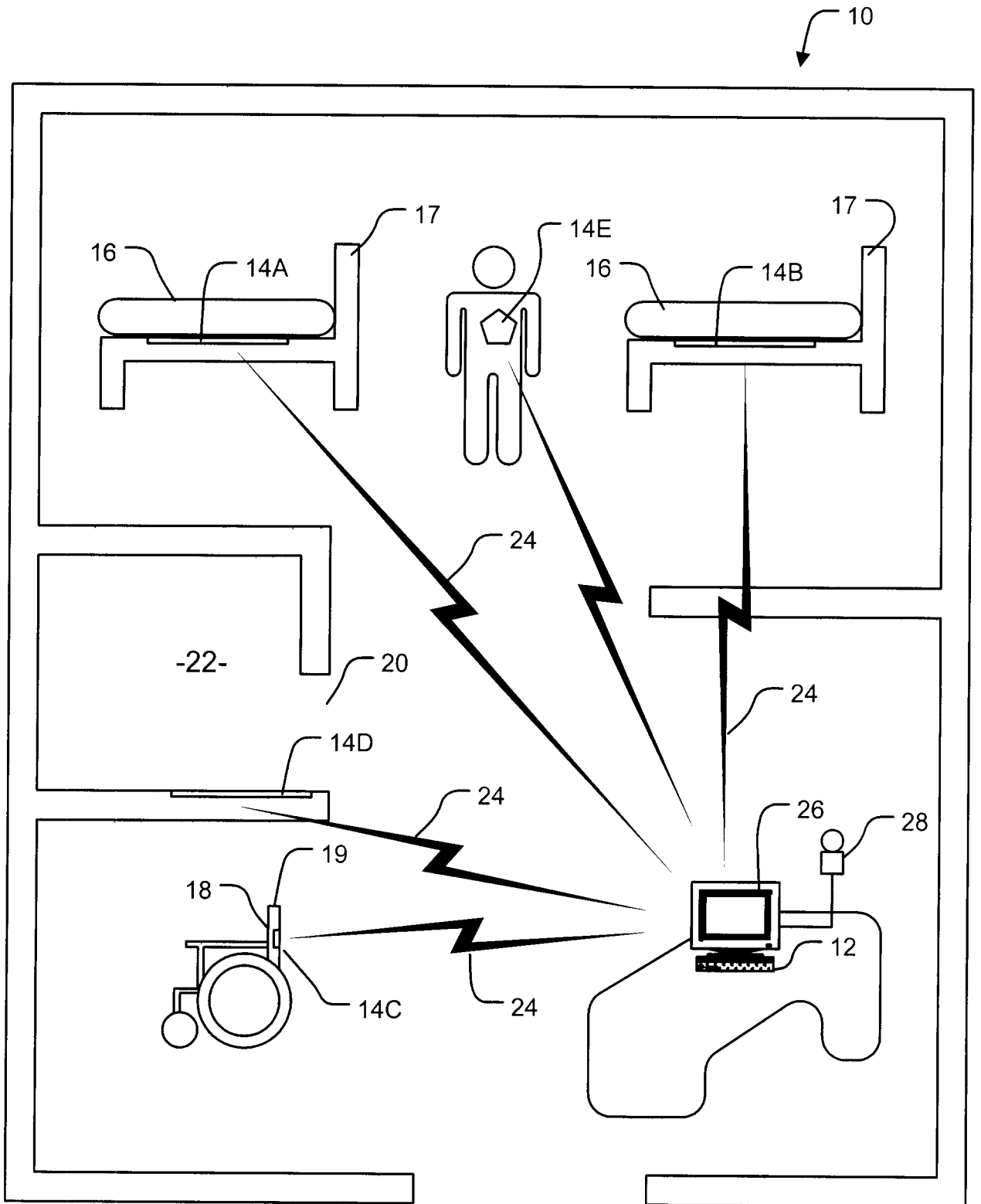

FIGURE 1

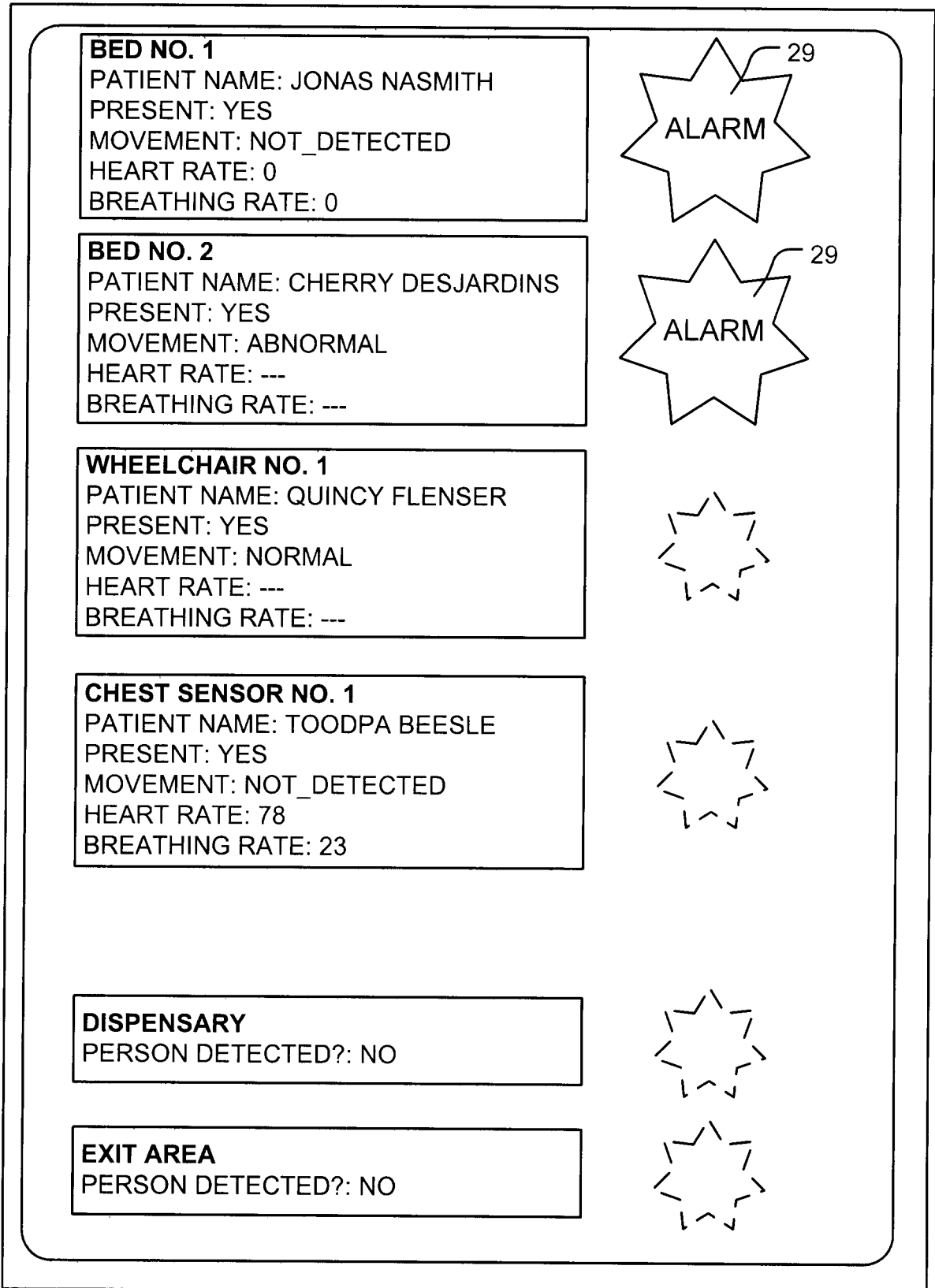

FIGURE 2

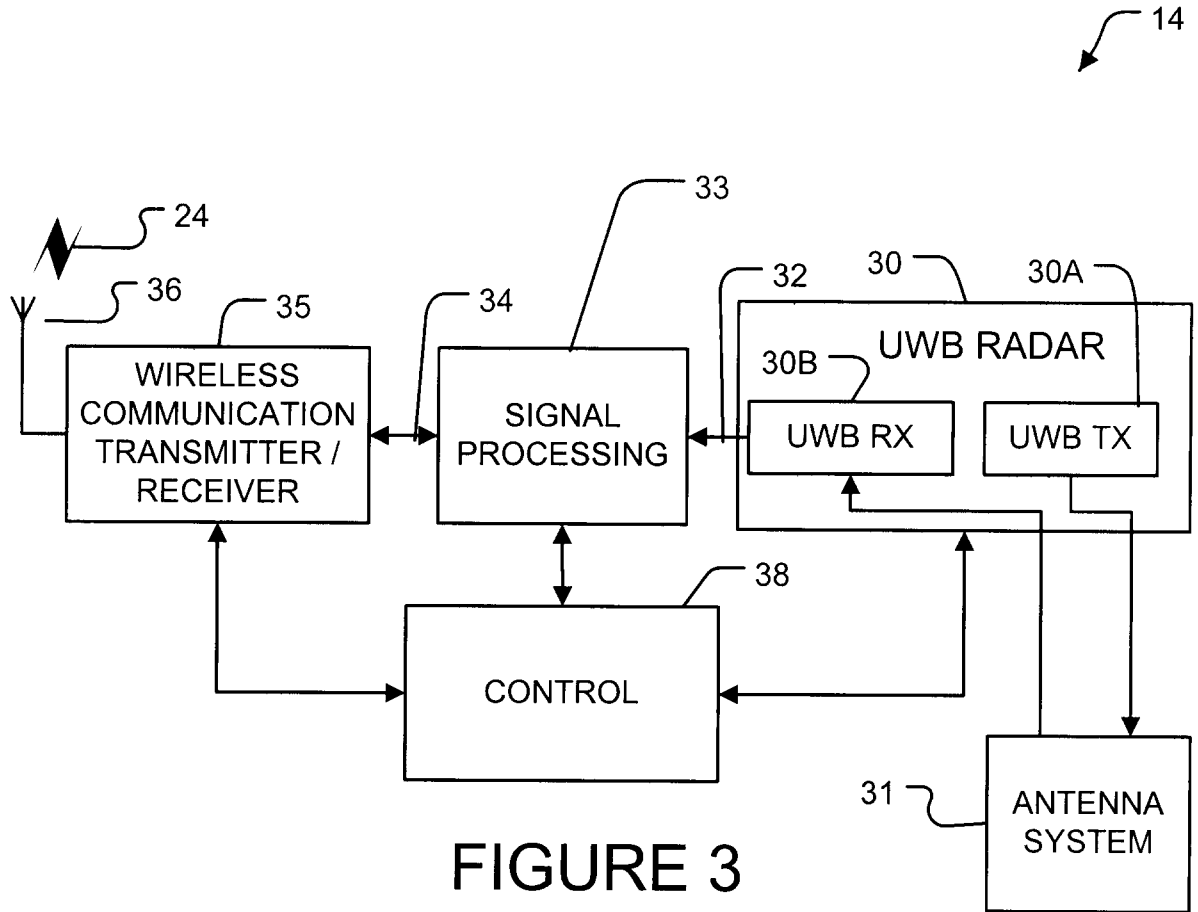

FIGURE 3

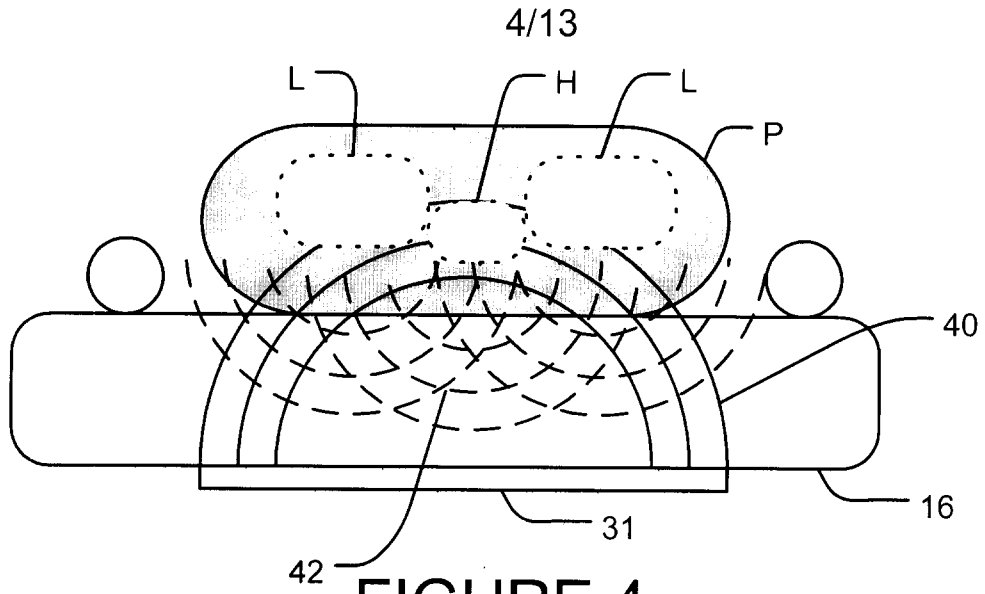

FIGURE 4

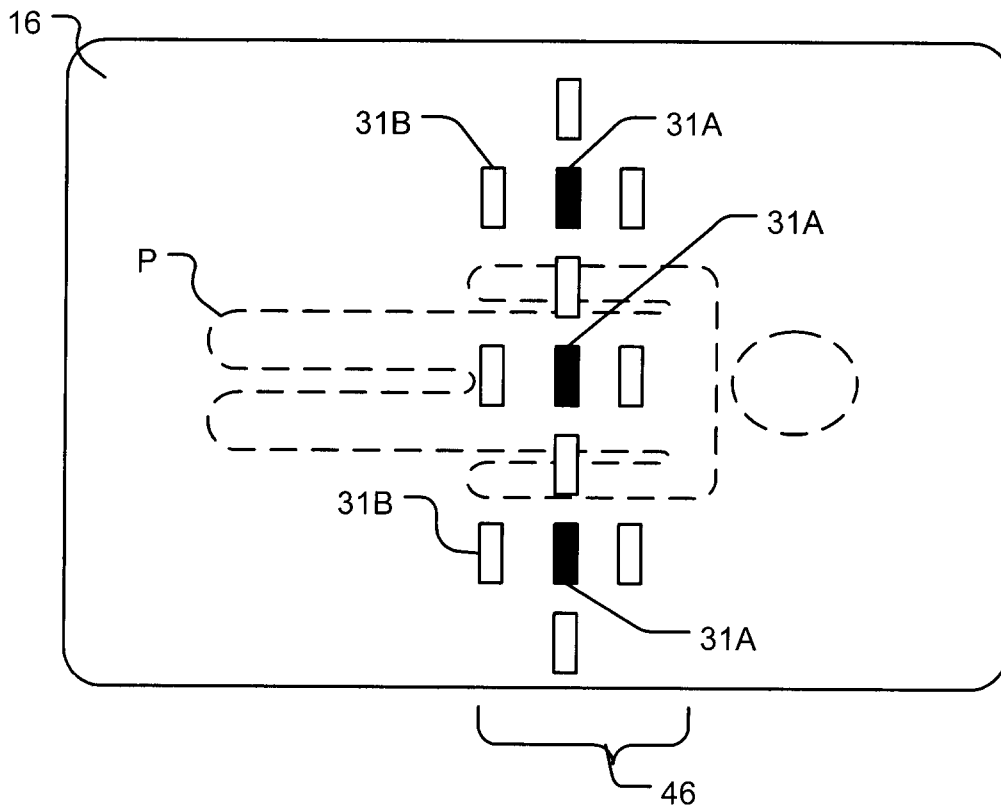

FIGURE 4A

5/13

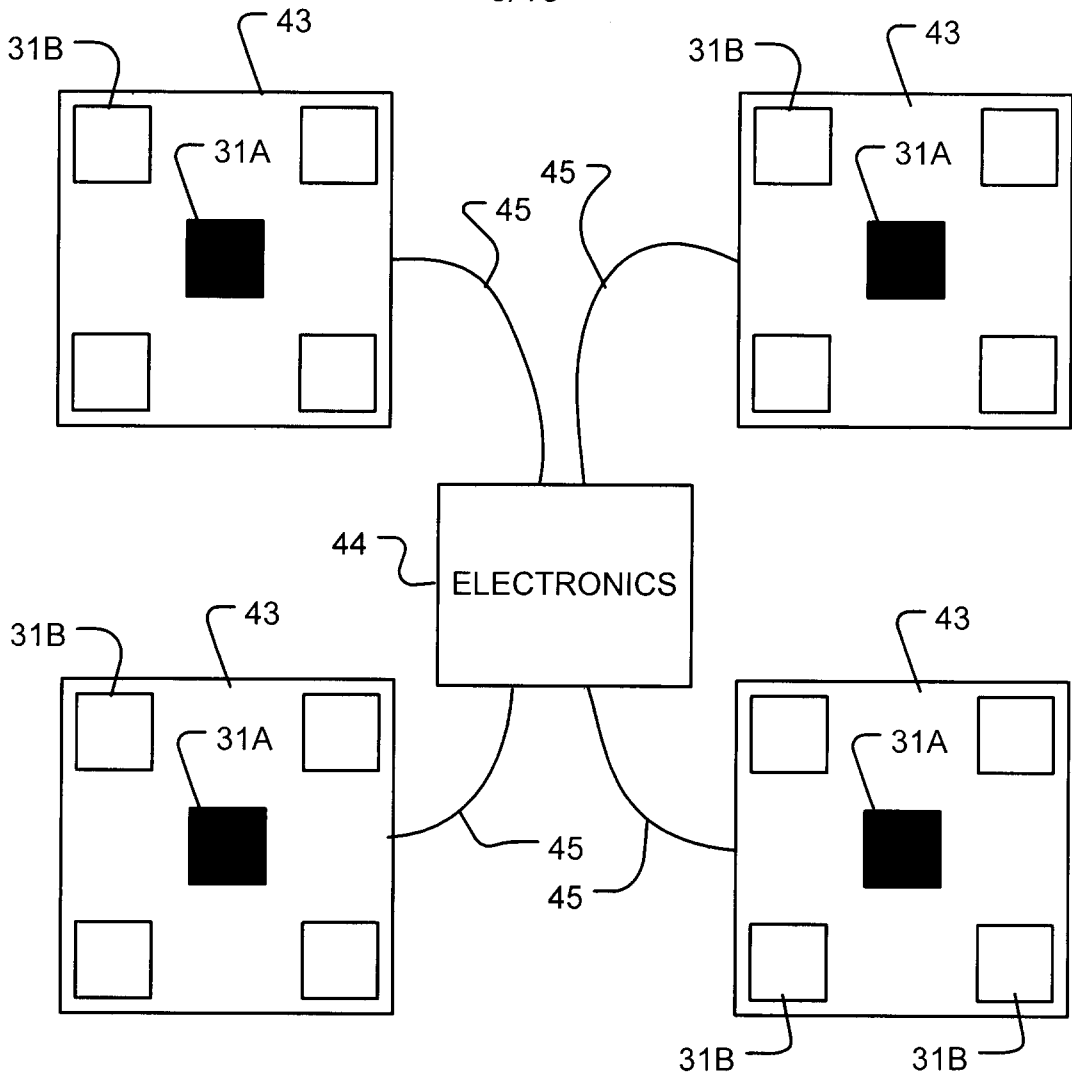

FIGURE 4B

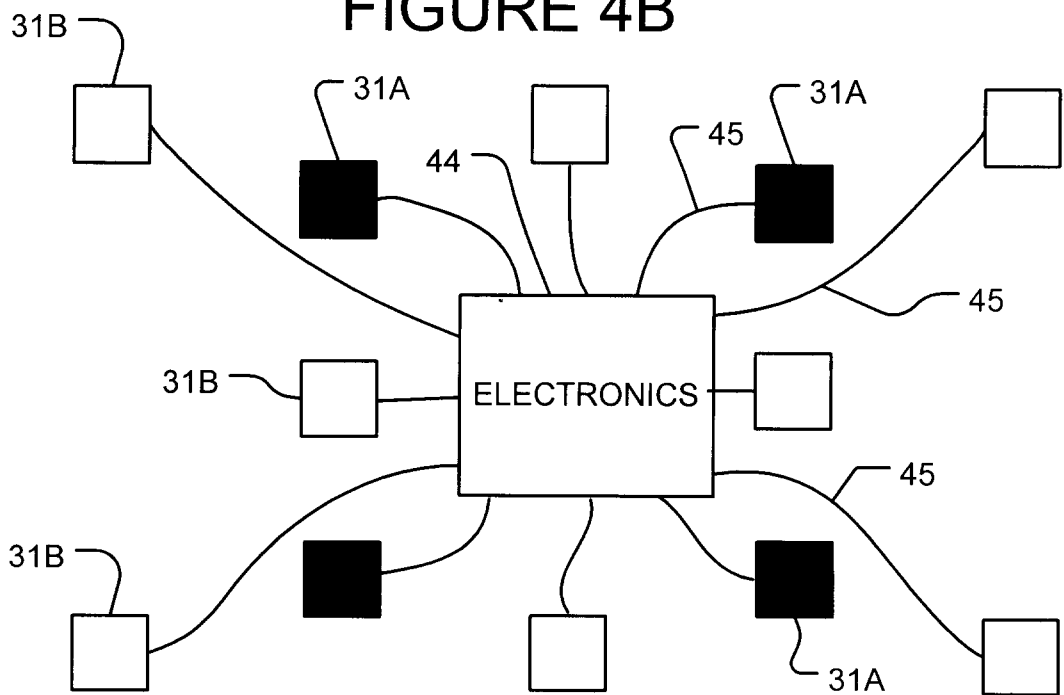

FIGURE 4C

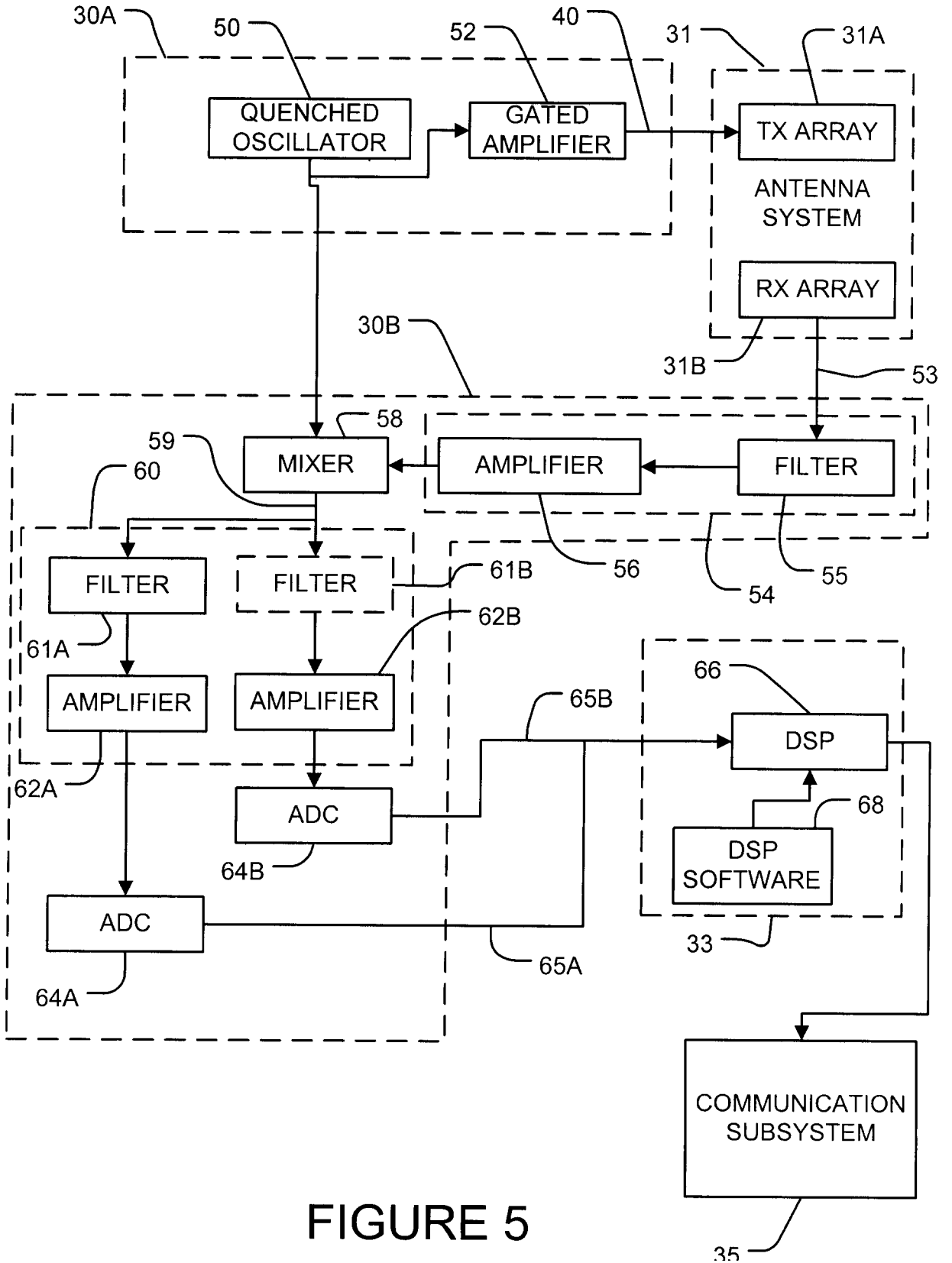

FIGURE 5

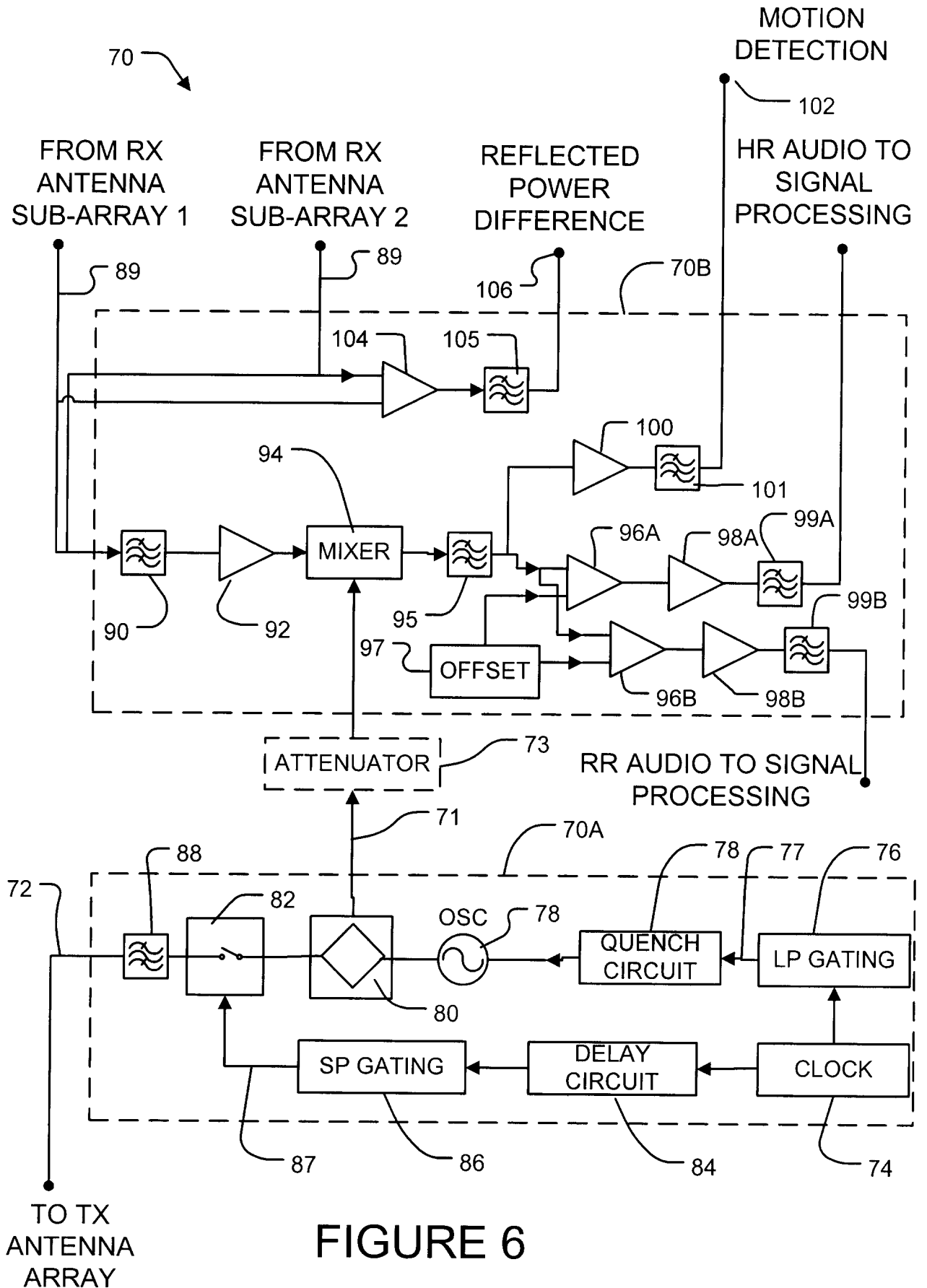

FIGURE 6

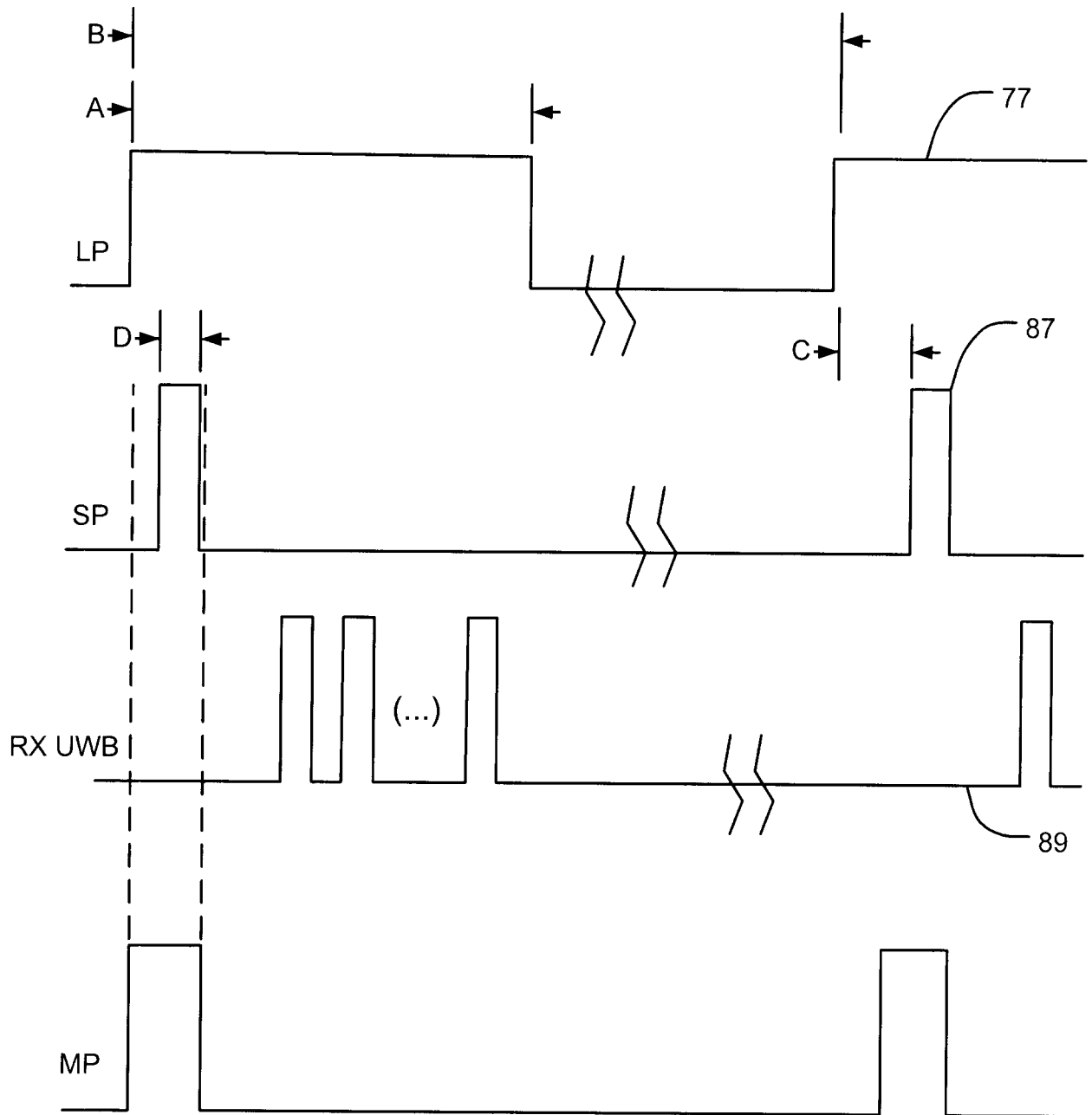

FIGURE 7

9/13

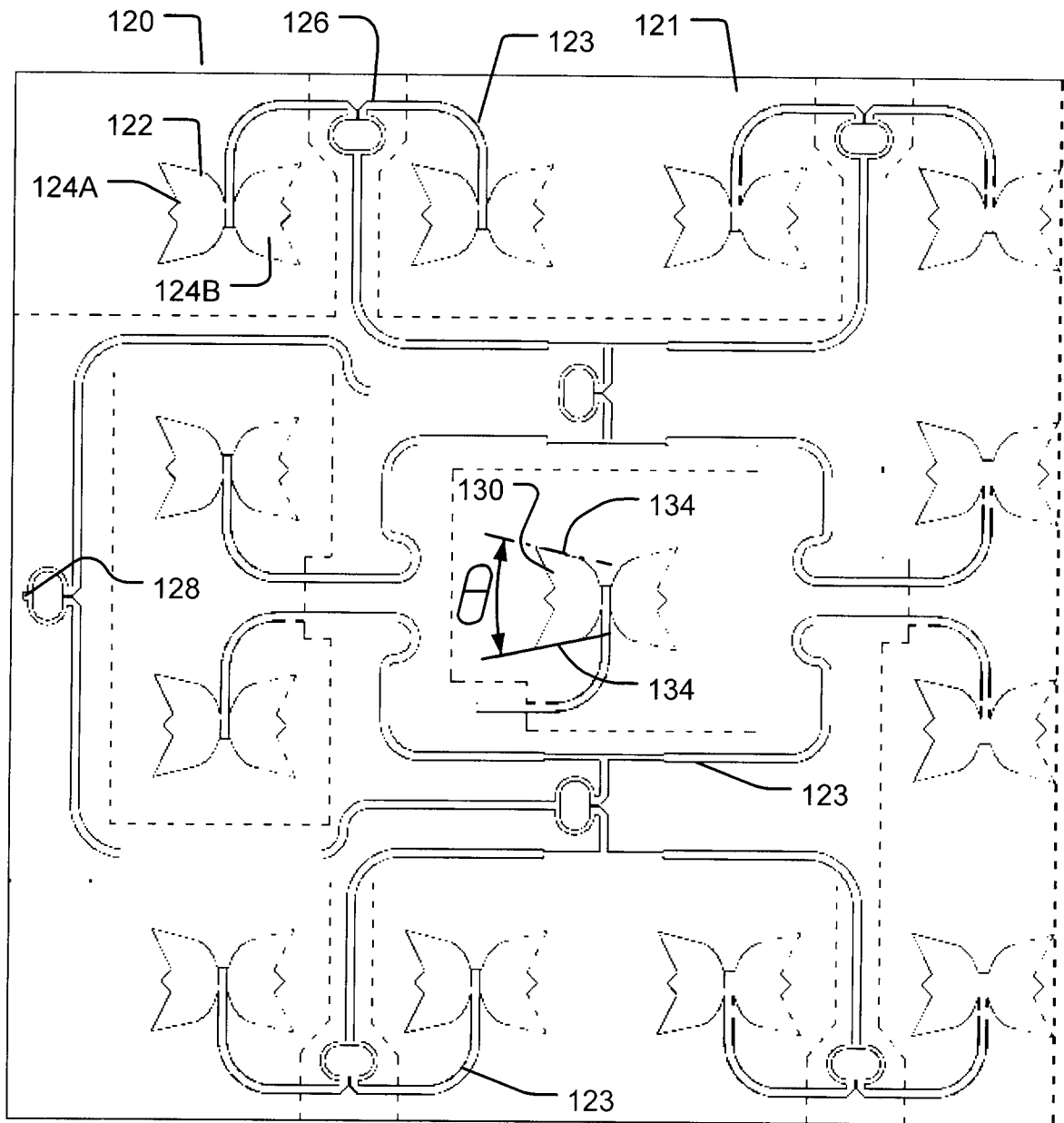

FIGURE 8

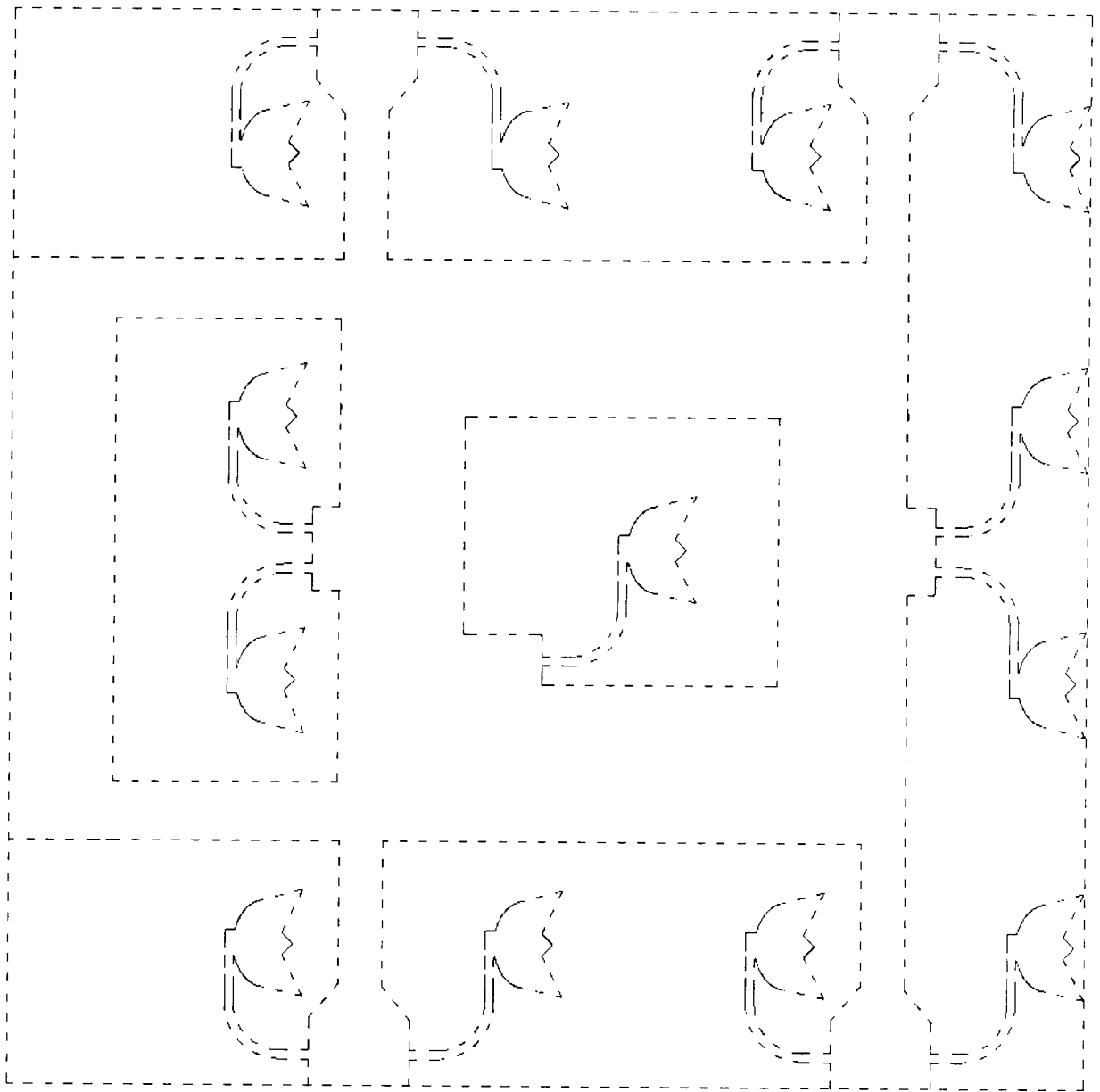

FIGURE 8A

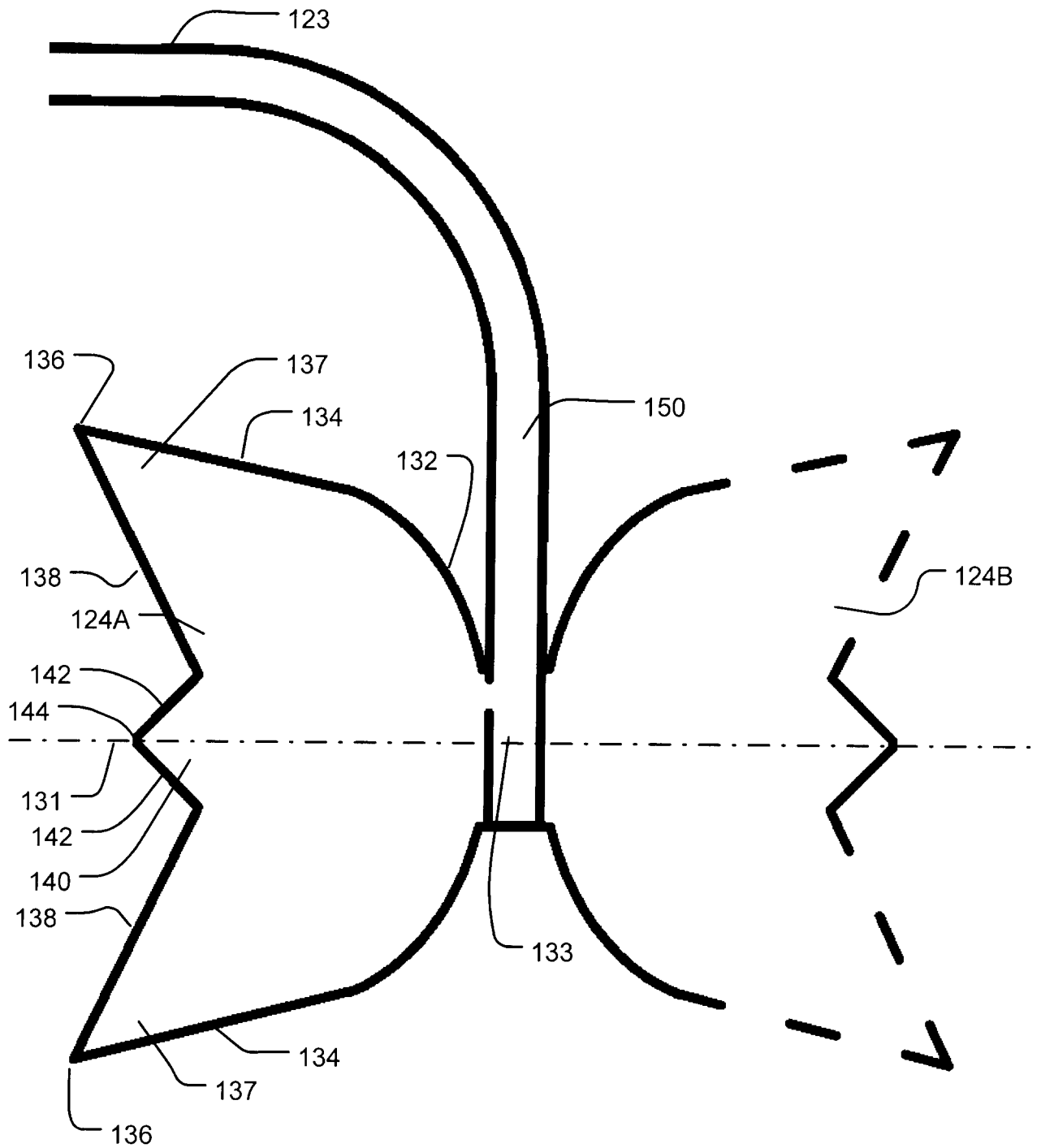

FIGURE 8B

12/13

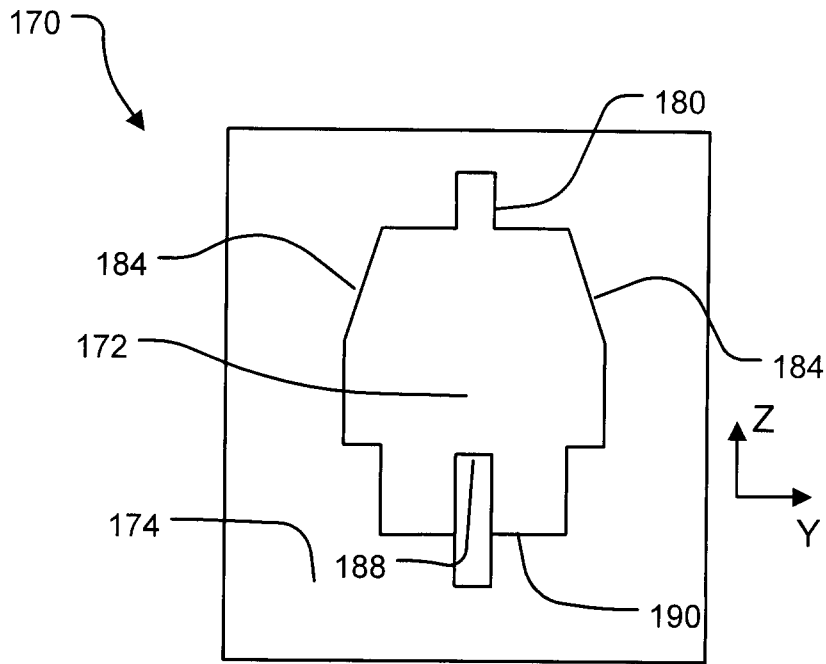

FIGURE 9

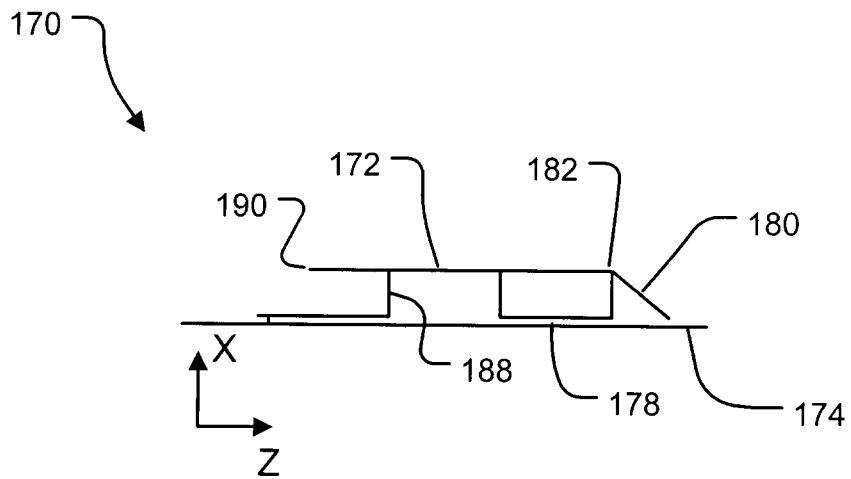

FIGURE 9A

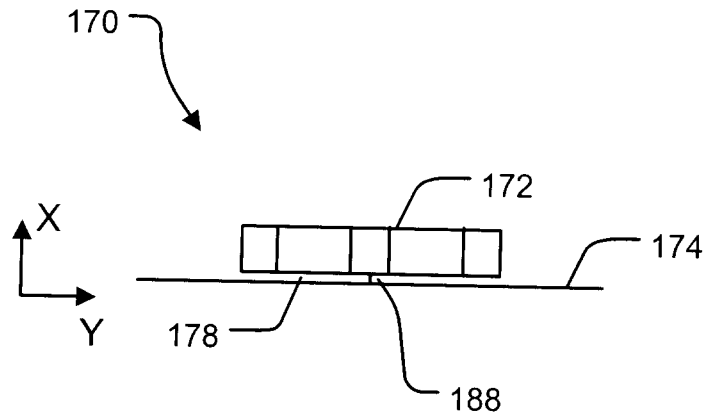

FIGURE 9B

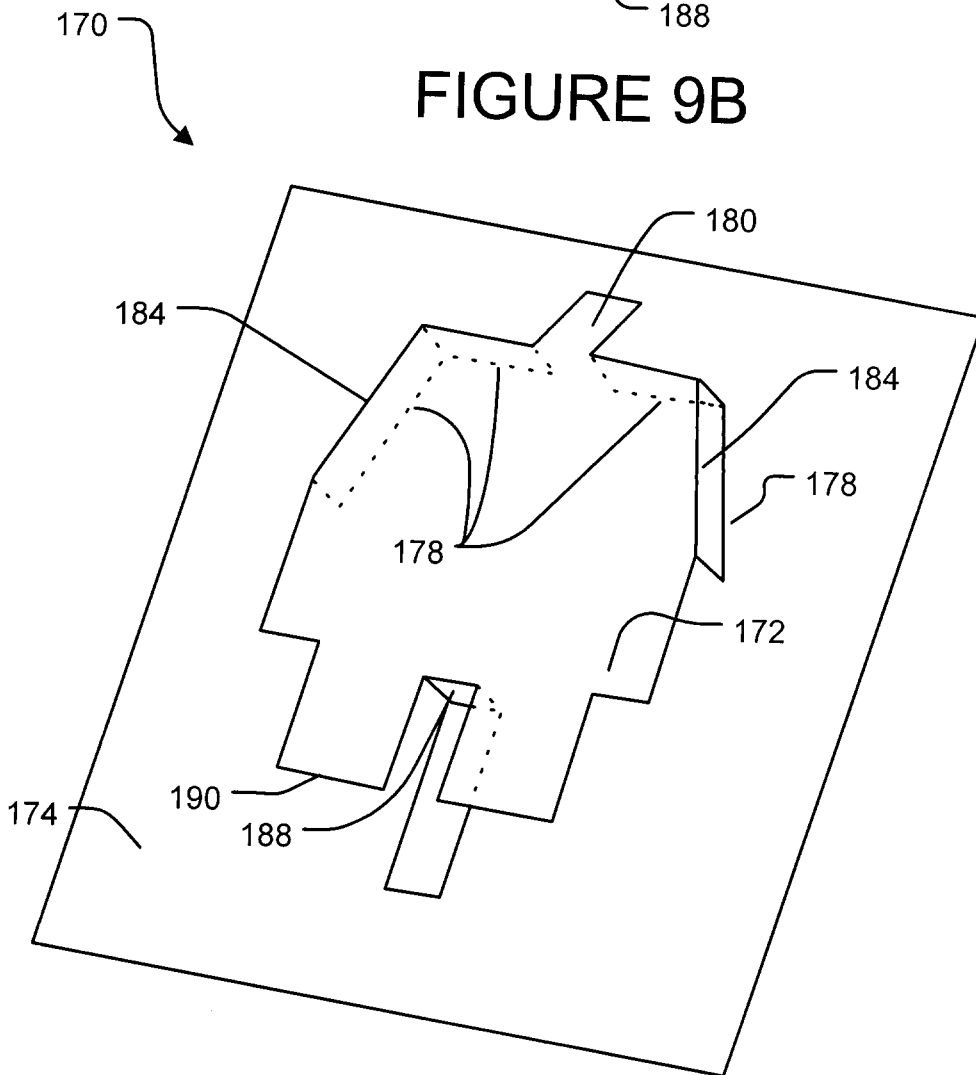

FIGURE 9C

INTERNATIONAL SEARCH REPORT

International application No.
PCT/CA2007/000365

<p>A. CLASSIFICATION OF SUBJECT MATTER IPC: A61B 5/00 (2006.01) , A47C 17/86 (2006.01) , A47C 7/62 (2006.01) , A61B 5/024 (2006.01) , A61B 5/08 (2006.01) , A61B 5/11 (2006.01) (more IPCs on the last page) According to International Patent Classification (IPC) or to both national classification and IPC</p>																			
<p>B. FIELDS SEARCHED</p> <p>Minimum documentation searched (classification system followed by classification symbols) IPC: A61B 5/00, A47C 17/86, A47C 7/62, A61B 5/024, A61B 5/08, A61B 5/11, G01S 13/04, G01S 13/50, G01S 13/88, G01S 7/04, G01S 7/32, G01S 7/41, G08B 21/02, G08C 17/02, H01Q 1/36, A61B 5/0255</p> <p>Documentation searched other than minimum documentation to the extent that such documents are included in the fields searched</p> <p>Electronic database(s) consulted during the international search (name of database(s) and, where practicable, search terms used) Databases: Delphion, Questel Orbit, Pluspat, CPD (Canadian Patent Database), Google Keywords: UWB, antenna, array, system, monitor, human, CW (continuous wave), wideband, signal, animal, human</p>																			
<p>C. DOCUMENTS CONSIDERED TO BE RELEVANT</p> <table border="1" style="width:100%; border-collapse: collapse;"> <thead> <tr> <th style="width:10%;">Category*</th> <th style="width:60%;">Citation of document, with indication, where appropriate, of the relevant passages</th> <th style="width:30%;">Relevant to claim No.</th> </tr> </thead> <tbody> <tr> <td align="center">X</td> <td>US 2004/0100376 27 May 2004 (27-05-2004) Lye et al. ** see abstract, [0002], [0007], [0010], [0030], [0032]-[0035], [0037]-[0040], [0053]-[0056], see also Fig.1-5)</td> <td align="center">1</td> </tr> <tr> <td align="center">A</td> <td>US6 900 732 31 May 2005 (31-05-2005) Richards, ** see whole document**</td> <td align="center">1-61</td> </tr> <tr> <td align="center">A</td> <td>US 5 361 070 1 Nov.1994 (01-11-1994) McEwan, ** see whole document**</td> <td align="center">1-61</td> </tr> <tr> <td align="center">A</td> <td>US 6 919 838 19 Jul.2005 (19-07-2005) Santhoff, ** see whole document**</td> <td align="center">1-61</td> </tr> <tr> <td align="center">A</td> <td>US 5 455 593 3 Oct.1995 (03-10-1995) Ross ** see whole document**</td> <td align="center">1-61</td> </tr> </tbody> </table>		Category*	Citation of document, with indication, where appropriate, of the relevant passages	Relevant to claim No.	X	US 2004/0100376 27 May 2004 (27-05-2004) Lye et al. ** see abstract, [0002], [0007], [0010], [0030], [0032]-[0035], [0037]-[0040], [0053]-[0056], see also Fig.1-5)	1	A	US6 900 732 31 May 2005 (31-05-2005) Richards, ** see whole document**	1-61	A	US 5 361 070 1 Nov.1994 (01-11-1994) McEwan, ** see whole document**	1-61	A	US 6 919 838 19 Jul.2005 (19-07-2005) Santhoff, ** see whole document**	1-61	A	US 5 455 593 3 Oct.1995 (03-10-1995) Ross ** see whole document**	1-61
Category*	Citation of document, with indication, where appropriate, of the relevant passages	Relevant to claim No.																	
X	US 2004/0100376 27 May 2004 (27-05-2004) Lye et al. ** see abstract, [0002], [0007], [0010], [0030], [0032]-[0035], [0037]-[0040], [0053]-[0056], see also Fig.1-5)	1																	
A	US6 900 732 31 May 2005 (31-05-2005) Richards, ** see whole document**	1-61																	
A	US 5 361 070 1 Nov.1994 (01-11-1994) McEwan, ** see whole document**	1-61																	
A	US 6 919 838 19 Jul.2005 (19-07-2005) Santhoff, ** see whole document**	1-61																	
A	US 5 455 593 3 Oct.1995 (03-10-1995) Ross ** see whole document**	1-61																	
<p><input type="checkbox"/> Further documents are listed in the continuation of Box C. <input checked="" type="checkbox"/> See patent family annex.</p>																			
<table style="width:100%; border-collapse: collapse;"> <tr> <td style="width:50%; vertical-align: top;"> <p>* Special categories of cited documents :</p> <p>“A” document defining the general state of the art which is not considered to be of particular relevance</p> <p>“E” earlier application or patent but published on or after the international filing date</p> <p>“L” document which may throw doubts on priority claim(s) or which is cited to establish the publication date of another citation or other special reason (as specified)</p> <p>“O” document referring to an oral disclosure, use, exhibition or other means</p> <p>“P” document published prior to the international filing date but later than the priority date claimed</p> </td> <td style="width:50%; vertical-align: top;"> <p>“T” later document published after the international filing date or priority date and not in conflict with the application but cited to understand the principle or theory underlying the invention</p> <p>“X” document of particular relevance; the claimed invention cannot be considered novel or cannot be considered to involve an inventive step when the document is taken alone</p> <p>“Y” document of particular relevance; the claimed invention cannot be considered to involve an inventive step when the document is combined with one or more other such documents, such combination being obvious to a person skilled in the art</p> <p>“&” document member of the same patent family</p> </td> </tr> </table>		<p>* Special categories of cited documents :</p> <p>“A” document defining the general state of the art which is not considered to be of particular relevance</p> <p>“E” earlier application or patent but published on or after the international filing date</p> <p>“L” document which may throw doubts on priority claim(s) or which is cited to establish the publication date of another citation or other special reason (as specified)</p> <p>“O” document referring to an oral disclosure, use, exhibition or other means</p> <p>“P” document published prior to the international filing date but later than the priority date claimed</p>	<p>“T” later document published after the international filing date or priority date and not in conflict with the application but cited to understand the principle or theory underlying the invention</p> <p>“X” document of particular relevance; the claimed invention cannot be considered novel or cannot be considered to involve an inventive step when the document is taken alone</p> <p>“Y” document of particular relevance; the claimed invention cannot be considered to involve an inventive step when the document is combined with one or more other such documents, such combination being obvious to a person skilled in the art</p> <p>“&” document member of the same patent family</p>																
<p>* Special categories of cited documents :</p> <p>“A” document defining the general state of the art which is not considered to be of particular relevance</p> <p>“E” earlier application or patent but published on or after the international filing date</p> <p>“L” document which may throw doubts on priority claim(s) or which is cited to establish the publication date of another citation or other special reason (as specified)</p> <p>“O” document referring to an oral disclosure, use, exhibition or other means</p> <p>“P” document published prior to the international filing date but later than the priority date claimed</p>	<p>“T” later document published after the international filing date or priority date and not in conflict with the application but cited to understand the principle or theory underlying the invention</p> <p>“X” document of particular relevance; the claimed invention cannot be considered novel or cannot be considered to involve an inventive step when the document is taken alone</p> <p>“Y” document of particular relevance; the claimed invention cannot be considered to involve an inventive step when the document is combined with one or more other such documents, such combination being obvious to a person skilled in the art</p> <p>“&” document member of the same patent family</p>																		
<p>Date of the actual completion of the international search 20 May 2007 (20-06-2007)</p>	<p>Date of mailing of the international search report 21 June 2007 (21-06-2007)</p>																		
<p>Name and mailing address of the ISA/CA Canadian Intellectual Property Office Place du Portage I, C114 - 1st Floor, Box PCT 50 Victoria Street Gatineau, Quebec K1A 0C9 Facsimile No.: 001-819-953-2476</p>	<p>Authorized officer Karen Oprea 819- 934-2668</p>																		

INTERNATIONAL SEARCH REPORTInternational application No.
PCT/CA2007/000365**Box No. II Observations where certain claims were found unsearchable (Continuation of item 2 of the first sheet)**

This international search report has not been established in respect of certain claims under Article 17(2)(a) for the following reasons :

1. Claim Nos. :
because they relate to subject matter not required to be searched by this Authority, namely :

claims 62 and 63 are directed to an antenna having features, combination of features or sub-combination of features described herein with reference to Figures 8-9C. Such claims are considered omnibus claims, thereby no opinion is required by this Authority.
2. Claim Nos. :
because they relate to parts of the international application that do not comply with the prescribed requirements to such an extent that no meaningful international search can be carried out, specifically :
3. Claim Nos. :
because they are dependant claims and are not drafted in accordance with the second and third sentences of Rule 6.4(a).

Box No. III Observations where unity of invention is lacking (Continuation of item 3 of first sheet)

This International Searching Authority found multiple inventions in this international application, as follows :

1. As all required additional search fees were timely paid by the applicant, this international search report covers all searchable claims.
2. As all searchable claims could be searched without effort justifying additional fees, this Authority did not invite payment of additional fees.
3. As only some of the required additional search fees were timely paid by the applicant, this international search report covers only those claims for which fees were paid, specifically claim Nos. :
4. No required additional search fees were timely paid by the applicant. Consequently, this international search report is restricted to the invention first mentioned in the claims; it is covered by claim Nos. :

Remark on Protest The additional search fees were accompanied by the applicant's protest and, where applicable, the payment of a protest fee.

The additional search fees were accompanied by the applicant's protest but the applicable protest fee was not paid within the time limit specified in the invitation.

No protest accompanied the payment of additional search fees.

INTERNATIONAL SEARCH REPORT
Information on patent family members

International application No.
PCT/CA2007/000365

Patent Document Cited in Search Report	Publication Date	Patent Family Member(s)	Publication Date
US2004100376	27-05-2004	AU2003263969 A1	18-06-2004
		BR0316166 A	27-09-2005
		CA2505749 A1	10-06-2004
		CN1700879 A	23-11-2005
		EP1569548 A1	07-09-2005
		JP2006507078T T	02-03-2006
		KR20050086556 A	30-08-2005
		MXPA05004979 A	02-08-2005
		US2004100376 A1	27-05-2004
		WO2004047630 A1	10-06-2004
US6900732		AT298093T T	15-07-2005
		AU762773B B2	03-07-2003
		AU2347800 A	30-04-2001
		AU3360199 A	18-10-1999
		CA2325381 A1	30-09-1999
		DE69925823D D1	21-07-2005
		EP1071967 A1	31-01-2001
		EP1221205 A1	10-07-2002
		US6133876 A	17-10-2000
		US6297773 B1	02-10-2001
		US6300903 B1	09-10-2001
		US6466125 B1	15-10-2002
		US6469628 B1	22-10-2002
		US6489893 B1	03-12-2002
		US6492904 B2	10-12-2002
US5361070		AT214853T T	15-04-2002
		AT217977T T	15-06-2002
		AT219252T T	15-06-2002
		AT233904T T	15-03-2003
		AT278969T T	15-10-2004
		AU3499995 A	27-03-1996
		AU4742296 A	10-07-1996
		AU6249396 A	24-12-1996
		AU6376696 A	16-10-1996
		AU6684496 A	05-03-1997
		AU6842196 A	05-03-1997
		AU6905494 A	12-12-1994
		CA2160351 A1	27-10-1994
		CA2160352 A1	27-10-1994
		CA2162257 A1	24-11-1994
		CA2199120 A1	14-03-1996
		CA2208070 A1	27-06-1996
		CA2215506 A1	03-10-1996
		CA2223756 A1	12-12-1996
		CA2503382 A1	27-10-1994
		CN1151382C C	26-05-2004
		DE69425373D D1	31-08-2000
		DE69425373T T2	22-02-2001
		DE69430195D D1	25-04-2002
		DE69430195T T2	24-10-2002
		DE69430801D D1	18-07-2002
		DE69430801T T2	16-01-2003
		DE69434064D D1	11-11-2004
		DE69434064T T2	06-10-2005
		DE69525651D D1	04-04-2002
		DE69525651T T2	10-10-2002
		DE69529830D D1	10-04-2003
		DE69529830T T2	20-11-2003
		DE69621331D D1	27-06-2002
		DE69621331T T2	09-01-2003
		DE69623481D D1	10-10-2002
		DE69623481T T2	20-02-2003
		DE69627488D D1	22-05-2003
		DE69627488T T2	24-12-2003
		EP0694171 A1	31-01-1996
EP0694235 A1	31-01-1996		

INTERNATIONAL SEARCH REPORT

International application No.
PCT/CA2007/000365

DE69627488D D1	22-05-2003
DE69627488T T2	24-12-2003
EP0694171 A1	31-01-1996
EP0694235 A1	31-01-1996
EP0700528 A1	13-03-1996
EP0779990 A1	25-06-1997
EP0799428 A1	08-10-1997
EP0829020 A2	18-03-1998
EP0830566 A1	25-03-1998
EP0842440 A1	20-05-1998
EP1178330 A1	06-02-2002
ES2174874T T3	16-11-2002
JP3471803B2 B2	02-12-2003
JP3573747B2 B2	06-10-2004
JP3648236B2 B2	18-05-2005
JP3701968B2 B2	05-10-2005
JP3891359B2 B2	14-03-2007
JP3897803B2 B2	28-03-2007
JP10505671T T	02-06-1998
JP10511182T T	27-10-1998
JP11503229T T	23-03-1999
JP11506825T T	15-06-1999
US5345471 A	06-09-1994
US5361070 A	01-11-1994
US5457394 A	10-10-1995
US5510800 A	23-04-1996
US5512834 A	30-04-1996
US5517198 A	14-05-1996
US5519400 A	21-05-1996
US5523760 A	04-06-1996
US5576627 A	19-11-1996
US5589838 A	31-12-1996
US5661490 A	26-08-1997
US5757320 A	26-05-1998
US5767953 A	16-06-1998
US5774091 A	30-06-1998
US5805110 A	08-09-1998
WO9424579 A1	27-10-1994
WO9424788 A1	27-10-1994
WO9427168 A1	24-11-1994
WO9607928 A1	14-03-1996
WO9619737 A1	27-06-1996
WO9630771 A2	03-10-1996
WO9639612 A1	12-12-1996
WO9705760 A2	20-02-1997
WO9706447 A1	20-02-1997

US6919838	19-07-2005	US6919838 B2	19-07-2005
		WO03042919 A2	22-05-2003

US5455593	03-10-1995	US5455593 A	03-10-1995
-----------	------------	-------------	------------

专利名称(译)	超宽带监控系统和天线		
公开(公告)号	EP1996068A1	公开(公告)日	2008-12-03
申请号	EP2007710699	申请日	2007-03-06
[标]申请(专利权)人(译)	无线2000射频与超宽带技术		
申请(专利权)人(译)	无线射频2000 UWB与TECHNOLOGIES LTD.		
当前申请(专利权)人(译)	无线射频2000 UWB与TECHNOLOGIES LTD.		
[标]发明人	FOO SENGLLEE		
发明人	FOO, SENGLLEE		
IPC分类号	A61B5/00 A47C17/86 A47C7/62 A61B5/024 A61B5/08 A61B5/11 G01S13/04 G01S13/50 G01S13/88 G01S7/04 G01S7/32 G01S7/41 G08B21/02 G08C17/02 H01Q1/36 A61B5/0255		
CPC分类号	A61B5/002 A61B5/0205 A61B5/024 A61B5/0816 A61B5/103 A61B5/1113 A61B5/1115 A61B5/1117 A61B5/6892 A61B2562/0228 A61B2562/046 A61B2562/166 G01S7/003 G01S13/0209 G01S13/56 G01S13/886 H01Q9/285 H01Q21/0075 H01Q21/062 Y10S128/903 A61B5/02444 A61B5/05 A61B5/08 A61B5/6891 A61B5/7207 A61B5/742		
优先权	60/778908 2006-03-06 US		
其他公开文献	EP1996068A4		
外部链接	Espacenet		

摘要(译)

用于监测一个或多个生物体的生命体征的装置包括监测站和至少一个与监测站通信的传感器。传感器包括天线系统，耦合到天线系统的超宽带雷达系统，信号处理器和通信系统。信号处理器被连接以接收来自超宽带雷达系统的信号，并被配置为从信号中提取关于与天线系统相对应的感测体积中的人或动物的一个或多个生命体征的信息。通信系统被配置为将信息发送到监控站。