



(12) **EUROPEAN PATENT APPLICATION**

(43) Date of publication: **27.09.2000 Bulletin 2000/39** (51) Int Cl.7: **A61B 5/00, H04Q 9/10**

(21) Application number: **00302436.1**

(22) Date of filing: **24.03.2000**

(84) Designated Contracting States:  
**AT BE CH CY DE DK ES FI FR GB GR IE IT LI LU MC NL PT SE**  
 Designated Extension States:  
**AL LT LV MK RO SI**

(72) Inventors:  
 • **Brinsfield, James**  
**Mequon, Wisconsin 83097 (US)**  
 • **Steinike, Michael F.**  
**Grafton, Wisconsin 53024 (US)**

(30) Priority: **24.03.1999 US 275205**

(74) Representative: **Goode, Ian Roy et al**  
**GE LONDON PATENT OPERATION,**  
**Essex House,**  
**12/13 Essex Street**  
**London WC2R 3AA (GB)**

(71) Applicant: **GE Marquette Medical Systems, Inc.**  
**Milwaukee, Wisconsin 53223 (US)**

(54) **Patient monitoring system having two-way communication**

(57) A patient monitoring system (10) comprising a central station (14) for analyzing (18) and displaying (22) patient data; a system receiver (42) connected to the central station; and an antenna array (54) connected to the system receiver and including a plurality of antennae

(72), each having connected thereto a respective transmitter (66). A portable telemetry monitor (98) is connected to the patient, and includes a transmitter (102) and receiver (142) for communicating with the central station via the antenna array.

**FIG.1**

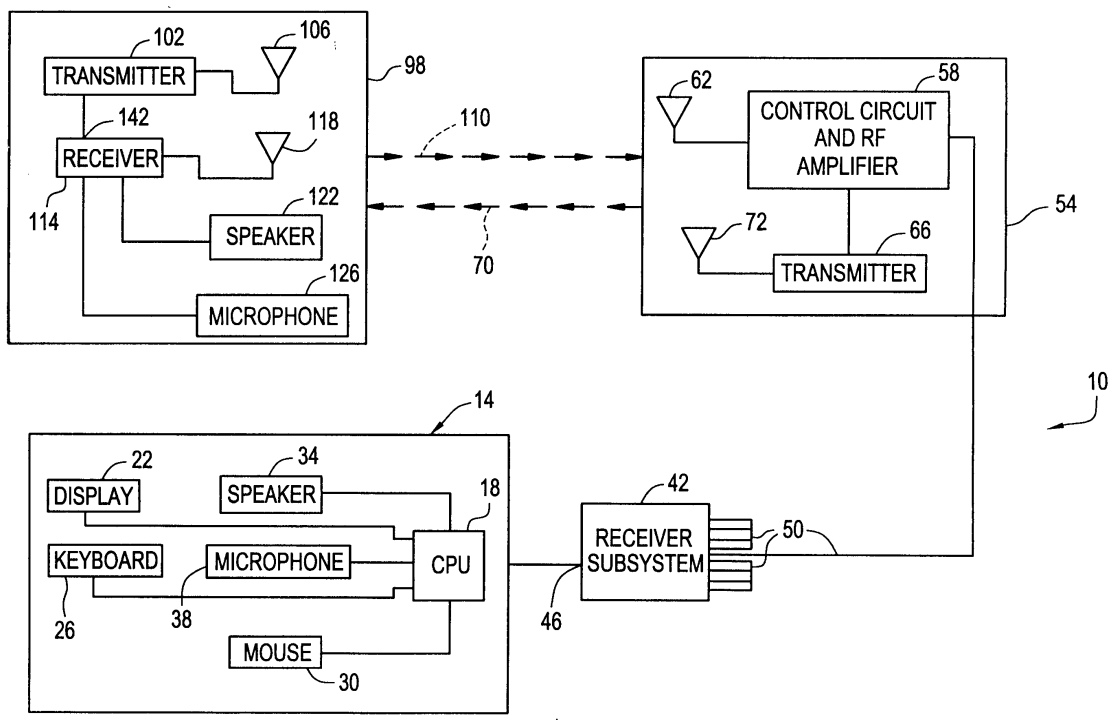

**EP 1 038 497 A1**

## Description

**[0001]** The invention relates to patient monitoring systems and particularly to patient monitoring systems that allow the patient to ambulate through the care unit of a clinical facility.

**[0002]** Most patient monitoring systems that allow a patient to ambulate through a care unit in a clinical facility use telemetry-based communication schemes. In its most common form, a patient wears a telemetry transmitter attached to the patient using common ECG electrodes. The telemetry transmitter acquires an ECG signal, conducts a nominal amount of filtering on the ECG signal, and transmits the ECG signal to an antenna array, typically located in the ceiling of the care unit. The ECG signal is conducted through the antenna array to a telemetry receiver, which in turn, is connected to a central station that analyzes and displays the ECG information for viewing and evaluation by the clinicians staffing the care units.

**[0003]** However, it is frequently desirable to be able to quickly locate the patient in a care unit if circumstances indicate that there is a problem with the patient. In other cases, it is desirable to be able to send data back from the central station to the telemetry transmitter.

**[0004]** Accordingly, the invention provides a telemetry-based patient monitoring system that allows the clinician to determine the location of the telemetry transmitter, and that allows the clinician to send data from the central station to the telemetry transmitter.

**[0005]** More specifically, the invention includes a portable telemetry transmitter. The telemetry transmitter is connected to the patient to receive physiological signals from the patient and transmit those signals to the antenna array. The telemetry transmitter includes an RF receiver.

**[0006]** The invention also provides a patient monitoring system including a central station for analyzing and displaying the physiological signals. The patient monitoring system further includes a receiver subsystem connected to the central station and an antenna array connected to the receiver subsystem. The antenna array includes a plurality of antennae each connected to an RF amplifier and supporting circuitry. Each antenna also has connected thereto a respective transmitter. In one form of the invention, each antenna includes a printed circuit board and the transmitter is mounted on the printed circuit board with the antenna circuitry, i.e., the RF amplifier and supporting circuitry. In another form of the invention, the transmitter is a discrete component that can be connected to the antenna after the system has already been installed in the care facility in order to "retro-fit" the patient monitoring system.

**[0007]** Each antenna is given a discrete address, the location of which is programmed into the central station. The antenna uses the antenna transmitter to transmit the address as a low power beacon. When the beacon is received by the telemetry transmitter, the telemetry

transmitter combines the physiological data with the address and transmits the combined data signal to the receiver subsystem via the antenna array. From the receiver subsystem, the data is sent to the central station to be processed and displayed as required by the clinicians.

**[0008]** The receiver subsystem also allows communication from the central station to the transmitter associated with each antenna. Most commonly, the data will be in the form of voice communications, and will be transmitted to the telemetry transmitter and output from the transmitter on a speaker so that the communication is audible to the patient or to the clinician caring for the patient.

**[0009]** In still another form of the invention, each telemetry transmitter includes a microphone for receiving voice data and transmitting the voice data back to the central station.

**[0010]** A principal advantage of the invention is to provide a telemetry-based patient monitoring system that allows for complete two-way communication of both voice and physiological data, and that allows the clinician to accurately detect the location of the telemetry transmitter.

**[0011]** It is another advantage of the invention to provide a way of retro-fitting existing telemetry-based patient monitoring systems with a transmitter at each antenna in the antenna array to thereby allow for complete two-way communication of voice and physiological data, and allow the clinician to accurately determine the location of the telemetry transmitter.

**[0012]** Other features and advantages of the invention are set forth in the following detailed description with reference to the accompanying drawings, in which:

**[0013]** Fig. 1 is a block diagram of the patient monitoring system embodying the invention.

**[0014]** Fig. 2 is a schematic of the antenna transmitter subsystem.

**[0015]** Fig. 3 is a schematic illustration of the portable telemetry unit receiver subsystem.

**[0016]** Shown in Fig. 1 of the drawings is a block diagram of a telemetry-based patient monitoring system 10 embodying the invention. As is commonly known in the art, the patient monitoring system 10 includes a central station 14. The central station 14 typically has a CPU or central processing unit 18, which, in its most common form is a computer. The central station 14 also includes a display or display units 22 connected to the CPU 18. The display 22 typically shows patient waveforms and other patient data.

**[0017]** The central station 14 also includes various means for the clinician to interact with the CPU 18. As shown in the drawing, these means include a keyboard 26 for entering information relating to the patient, a mouse 30 for controlling CPU operations, a speaker 34 for generating audible alarms, data or other audible information, and a microphone 38 for receiving audio information and transmitting that information in electronic

form to the CPU 18.

**[0018]** The central station 14 is connected to a receiver subsystem 42. The receiver subsystem 42 includes a single input/output (I/O) port 46 connected to the central station 14, and a series of I/O ports 50 connected to a plurality of antennae 54 spaced about the care unit to form an antenna array connected to the receiver subsystem 42. While the number of antennae 54 may vary in any particular situation, the antennae 54 are all identical and accordingly only the single antenna 54 shown in Fig. 1 will be described.

**[0019]** The antenna 54 includes a control circuit 58 coupled with a radio frequency (RF) amplifier. A common RF antenna 62 is connected to the control circuit and RF amplifier 58 so that incoming radio frequency signals are picked up by the RF antenna 62, and are transmitted to the control circuit and RF amplifier 58 where they are filtered, amplified and sent to the receiver subsystem 42.

**[0020]** The antenna 54 also includes an antenna transmitter circuit 66 connected to the control circuit and RF amplifier 58. The antenna transmitter circuit 66 generates a low power RF carrier signal 70 (represented as a phantom line in Fig. 1). Fig. 2 illustrates a schematic diagram of the antenna transmitter circuit 66. As shown in Fig. 2, the antenna transmitter circuit includes an EPROM-based 8-bit CMOS microcontroller 68 (Microchip Technology, Inc. Part No. PIC16C62X) connected to an RF antenna 72 through an inverting buffer 78 and a transmitter 82. While any appropriate transmitter can be used, the transmitter 82 prototyped for the preferred embodiment is a 303.825 megahertz hybrid transmitter (Model No. HX1006 produced by RF Monolithics, Inc.) As shown in Fig. 2, the antenna transmitter circuit 66 also includes an oscillator 86, and various support circuitry, as well as power connections 90 and common connections 94 as those of skill in the art understand are required for operating the antenna transmitter circuit 66.

**[0021]** Referring again to Fig. 1, the telemetry-based patient monitoring system 10 also includes a portable telemetry monitor 98. In use, the portable telemetry monitor 98 is connected to the patient (not shown) via ECG leads (also not shown) or through a patient connection suitable for measuring other patient parameters. Once connected to the patient, the patient is free to ambulate throughout the care unit as desired or able. As is commonly known in the art, the portable telemetry monitor 98 includes a transmitter sub-circuit 102 connected to a transmitting antenna 106. The transmitter sub-circuit 102 generates a RF carrier signal 110 (represented as a phantom line in Fig. 1) for transmitting patient and other data to the antenna array.

**[0022]** The portable telemetry monitor 98 also includes a receiver sub-circuit 114 connected to a receiving antenna 118, a speaker 122, and a microphone 126. Fig. 3 illustrates in greater detail a schematic illustration of the receiver sub-circuit 114. As shown in Fig. 3, the

receiver sub-circuit 114 includes an RF receiver 130 connected to antenna 118. While any appropriate RF receiver can be used, the RF receiver 130 prototyped in the preferred embodiment is a 303.825 megahertz amplifier-sequenced hybrid receiver (Model No. RX1120, manufactured by RF Monolithics, Inc.). The receiver sub-circuit 114 also includes support circuitry, power inputs 134 and common connections 138 as those of skill in the art understand are required for operating the receiver sub-circuit 114. The receiver sub-circuit 114 also includes an microprocessor input 142 connected to the microprocessor (not shown) of the portable telemetry unit. The microprocessor is responsible for receiving all physiological data and other incoming signals and routing them to the transmitter sub-circuit 102. Inverting buffer 144 is connected between microprocessor input 142 and RF receiver 130.

**[0023]** In operation, the antenna transmitter circuit 66 generally functions in a default or beacon mode. In this mode, the antenna transmitter circuit 66 generates an 8-bit address and transmits (via the low power RF carrier 70) the 8-bit address. In the lower power beacon mode, the carrier 70 is capable of being received by the portable telemetry monitor 98 at a range of approximately ten to twenty feet from the RF antenna 62. While the range of the low power beacon mode may vary, it is important that the range be sufficiently limited so as not to overlap with the low power beacon mode transmission of another antenna transmitter. The location of the RF antenna 62 is programmed into the central station 14 at the time of installation using the 8-bit address. In the preferred embodiment, the 8-bit address is retransmitted every 500 milliseconds and represents approximately five percent of the total available broadcast time of the antenna transmitter. The remaining 95 percent of the antenna transmitter broadcast time is kept available to be used for data communication.

**[0024]** The receiver sub-circuit 114 in the portable telemetry monitor 98 picks up the 8-bit sequence and combines the 8-bit sequence with the physiological patient data acquired by the portable telemetry monitor 98. The transmitter sub-circuit 102 in the portable telemetry monitor 98 then broadcasts the combined 8-bit address and physiological data signal back to the antenna array via the RF carrier signal 110. The signals at the various antennae 54 are then transmitted to the receiver subsystem 42 and from there, to the central station 14 for processing and subsequent display.

**[0025]** In the event that data communication is desired, i.e., that the clinician wishes to send information from the central station 14 to the portable telemetry monitor 98, the antenna transmitter circuit 66 switches into a communication mode. In this operational mode, a digital signal is encoded by the central station 14 and routed to all of the antennae 54 in the antenna array, where it is transmitted via the antenna transmitter 66 to the receiver sub-circuit 114 in the portable telemetry monitor 98. The information contained in this data can

be either digital voice communication or system command data. The data is sent with a header address that is unique to each individual portable telemetry monitor 98. In this way, only the portable telemetry monitor 98 that is intended to receive the information will process and respond to the information.

## Claims

### 1. A patient monitoring system comprising:

a central station for analyzing and displaying patient data;

a system receiver connected to the central station; and

an antenna array connected to the system receiver and including a plurality of antennae, each having connected thereto a respective transmitter.

### 2. A patient monitoring system as set forth in claim 1 and further comprising a portable patient monitor including a transmitter for transmitting data to the system receiver, and a receiver for receiving data from the respective transmitters.

### 3. A patient monitoring system comprising:

a portable transmitter connected to the patient so as to receive physiological data from the patient, the portable transmitter including a transmitter circuit for transmitting the physiological data and a receiver circuit connected to the transmitter circuit;

at least one antenna for receiving the physiological data;

a system receiver connected to the antenna; and

an antenna transmitter connected to the antenna.

### 4. A patient monitoring system as set forth in claim 3, and further comprising a central station connected to the system receiver, and wherein the system receiver transmits data from the antenna to the central station and transmits data from the central station to the antenna transmitter.

### 5. A patient monitoring system as set forth in claim 2 or claim 4 wherein the portable transmitter includes a microphone connected to the transmitter to allow the transmission of voice data from the patient to

the central station, and a speaker connected to the receiver to allow the transmission of voice data from the central station to the patient.

### 6. A patient monitoring system as set forth in claim 2 or claim 4 wherein the, or each, transmitter generates a location code unique to the respective antenna, and wherein data transmitted from the telemetry unit is combined with the location code before being transmitted to the central station.

### 7. A patient monitoring system as set forth in any one of claims 1 to 6 wherein the respective transmitters are telemetry transmitters.

### 8. A patient monitoring system as set forth in one of claims 1 to 7 wherein the, or each, antenna includes a circuit board and wherein the respective transmitter is mounted on the circuit board.

### 9. A patient monitoring system as set forth in any one of claims 1 to 8 wherein the, or each, antenna is a discrete component from the respective transmitter.

### 10. A method of locating a portable patient monitor relative to an antenna array in a patient monitoring system including a central station for analyzing and displaying patient data, an antenna array connected to the central station and including a plurality of antennae, each having connected thereto a respective transmitter, and a portable patient monitoring for acquiring patient data and including a portable transmitter for transmitting data to the central station, and a receiver for receiving data from the respective transmitter; the method comprising the steps of:

generating an address specific to each respective transmitter;

transmitting the address using a low power carrier signal so that a portable patient monitor in range of the respective transmitter will receive the address;

combining the patient data and the address into a second carrier signal; and

transmitting the second carrier signal back to the respective antenna for transmission to the central station.

### 11. A method as set forth in claim 10 wherein each antenna has a respective location, and wherein the method further comprises the act of programming the respective locations of the antenna into the central station.

### 12. A method as set forth in claim 10 and further comprising the act of transmitting data from the central station to the antenna array.

13. A method as set forth in claim 12 wherein the act of transmitting data from the central station to the antenna array includes the act of transmitting a header address unique to each antenna.

5

14. A method as set forth in claim 12 wherein the data is a voice data.

10

15

20

25

30

35

40

45

50

55

FIG. 1

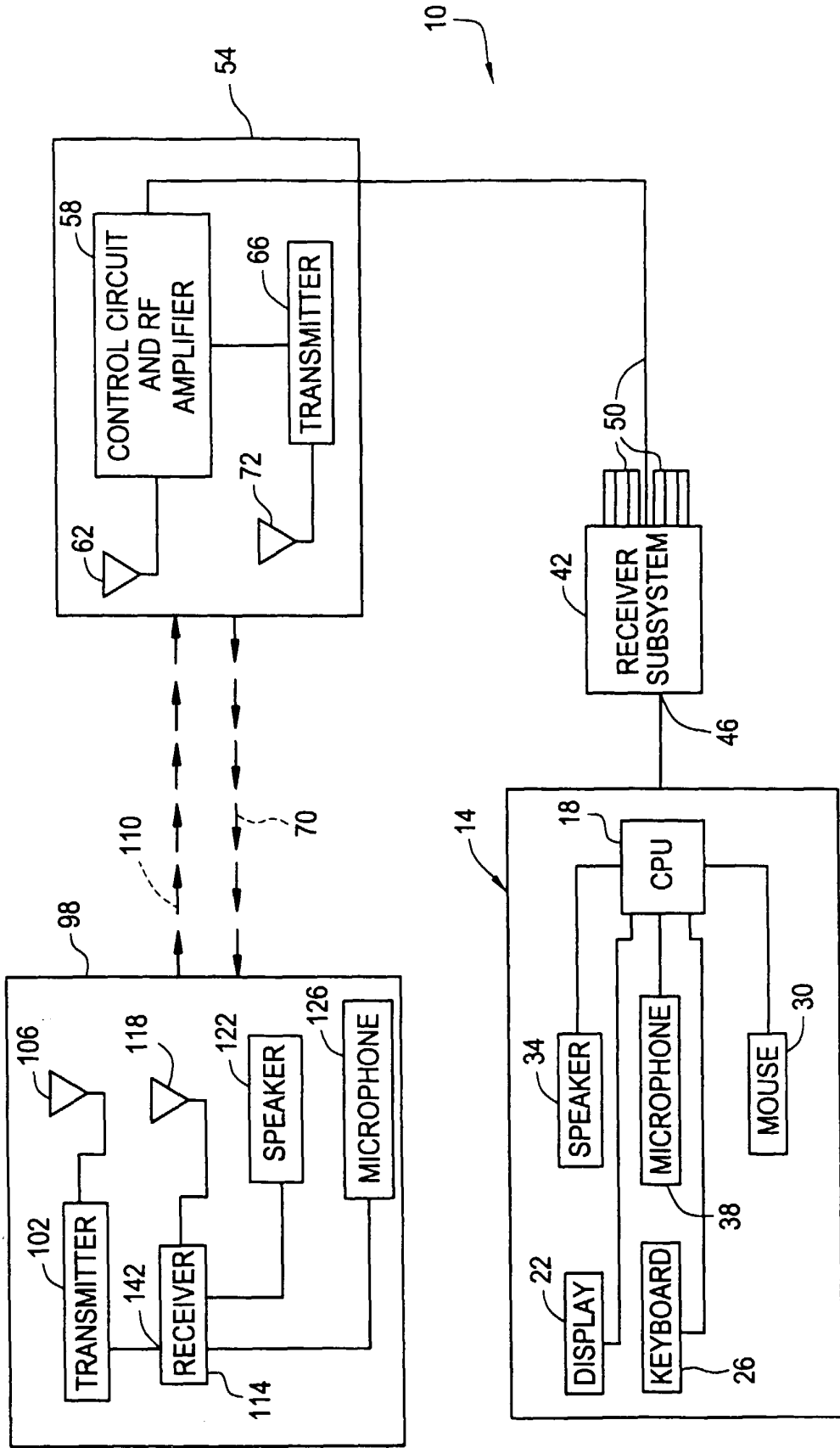

FIG.2

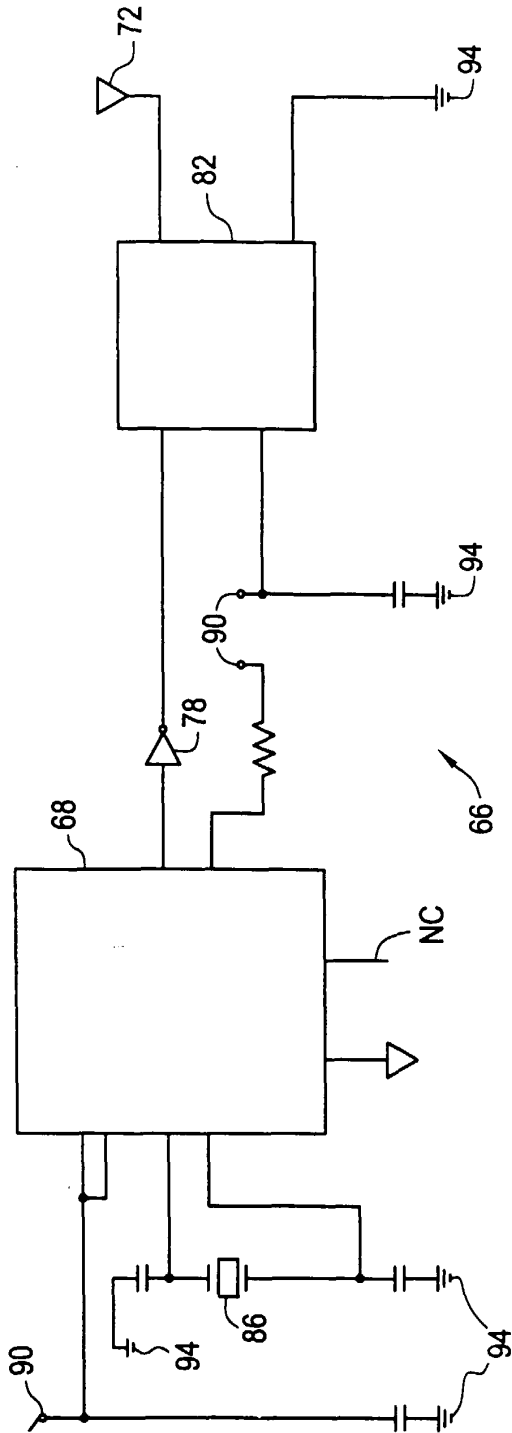
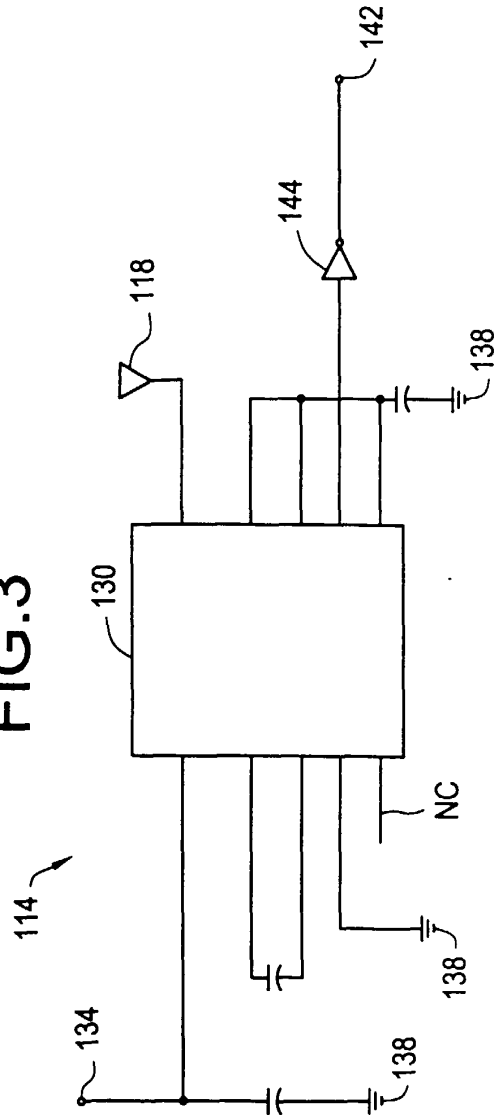

FIG.3





European Patent  
Office

EUROPEAN SEARCH REPORT

Application Number  
EP 00 30 2436

DOCUMENTS CONSIDERED TO BE RELEVANT			
Category	Citation of document with indication, where appropriate, of relevant passages	Relevant to claim	CLASSIFICATION OF THE APPLICATION (Int.Cl.7)
X	EP 0 602 459 A (SIEMENS MEDICAL SYSTEMS INC) 22 June 1994 (1994-06-22) * column 4, line 7 - column 6, line 45 * ---	1-4,6-13	A61B5/00 H04Q9/10
X	US 3 639 907 A (GREATBATCH WILSON) 1 February 1972 (1972-02-01) * column 2, line 10 - column 3, line 13 * -----	1-4,7-9	
			TECHNICAL FIELDS SEARCHED (Int.Cl.7)
			A61B H04Q
The present search report has been drawn up for all claims			
Place of search <b>THE HAGUE</b>		Date of completion of the search <b>29 June 2000</b>	Examiner <b>López-Pérez, M-C</b>
CATEGORY OF CITED DOCUMENTS X : particularly relevant if taken alone Y : particularly relevant if combined with another document of the same category A : technological background O : non-written disclosure P : intermediate document		T : theory or principle underlying the invention E : earlier patent document, but published on, or after the filing date D : document cited in the application L : document cited for other reasons ..... & : member of the same patent family, corresponding document	

EPO FORM 1505 03.82 (F04C01)

**ANNEX TO THE EUROPEAN SEARCH REPORT  
ON EUROPEAN PATENT APPLICATION NO.**

EP 00 30 2436

This annex lists the patent family members relating to the patent documents cited in the above-mentioned European search report. The members are as contained in the European Patent Office EDP file on The European Patent Office is in no way liable for these particulars which are merely given for the purpose of information.

29-06-2000

Patent document cited in search report	Publication date	Patent family member(s)	Publication date
EP 0602459 A	22-06-1994	AT 186187 T	15-11-1999
		DE 69326934 D	09-12-1999
		DE 69326934 T	30-03-2000
		US 5458123 A	17-10-1995
-----			
US 3639907 A	01-02-1972	NONE	
-----			

专利名称(译)	患者监护系统具有双向通信		
公开(公告)号	<a href="#">EP1038497A1</a>	公开(公告)日	2000-09-27
申请号	EP2000302436	申请日	2000-03-24
申请(专利权)人(译)	GE MARQUETTE医疗系统, INC.		
当前申请(专利权)人(译)	GE MARQUETTE医疗系统, INC.		
[标]发明人	BRINSFIELD JAMES STEINKE MICHAEL F		
发明人	BRINSFIELD, JAMES STEINKE, MICHAEL F.		
IPC分类号	A61B5/00 H04B7/24 H04Q9/00 H04Q9/10		
CPC分类号	H04Q9/10		
优先权	09/275205 1999-03-24 US		
其他公开文献	EP1038497B1		
外部链接	<a href="#">Espacenet</a>		

摘要(译)

一种患者监测系统 (10), 包括用于分析 (18) 和显示 (22) 患者数据的中心站 (14); 系统接收器 (42) 连接到中心站; 天线阵列 (54) 连接到系统接收器并包括多个天线 (72), 每个天线连接到相应的发射器 (66)。便携式遥测监视器 (98) 连接到患者, 并且包括发射器 (102) 和接收器 (142), 用于经由天线阵列与中心站通信。

