

(12) INTERNATIONAL APPLICATION PUBLISHED UNDER THE PATENT COOPERATION TREATY (PCT)

(19) World Intellectual Property Organization
International Bureau



(43) International Publication Date
20 January 2011 (20.01.2011)

PCT

(10) International Publication Number
WO 2011/008382 A1

(51) International Patent Classification:
A61B 5/00 (2006.01)

(21) International Application Number:
PCT/US2010/038105

(22) International Filing Date:
10 June 2010 (10.06.2010)

(25) Filing Language: English

(26) Publication Language: English

(30) Priority Data:
12/495,551 30 June 2009 (30.06.2009) US

(71) Applicant (for all designated States except US): NELL-COR PURITAN BENNETT LLC [US/US]; 6135 Gunbarrel Avenue, Boulder, Colorado 80301 (US).

(72) Inventor; and

(75) Inventor/Applicant (for US only): BESKO, David [US/US]; 4128 E. 139th Place, Thornton, CO 80602 (US).

(74) Agent: SCHAUMANN, Dave; 6135 Gunbarrel Avenue, Boulder, Colorado 80301 (US).

(81) Designated States (unless otherwise indicated, for every kind of national protection available): AE, AG, AL, AM, AO, AT, AU, AZ, BA, BB, BG, BH, BR, BW, BY, BZ, CA, CH, CL, CN, CO, CR, CU, CZ, DE, DK, DM, DO, DZ, EC, EE, EG, ES, FI, GB, GD, GE, GH, GM, GT, HN, HR, HU, ID, IL, IN, IS, JP, KE, KG, KM, KN, KP, KR, KZ, LA, LC, LK, LR, LS, LT, LU, LY, MA, MD, ME, MG, MK, MN, MW, MX, MY, MZ, NA, NG, NI, NO, NZ, OM, PE, PG, PH, PL, PT, RO, RS, RU, SC, SD, SE, SG, SK, SL, SM, ST, SV, SY, TH, TJ, TM, TN, TR, TT, TZ, UA, UG, US, UZ, VC, VN, ZA, ZM, ZW.

(84) Designated States (unless otherwise indicated, for every kind of regional protection available): ARIPO (BW, GH, GM, KE, LR, LS, MW, MZ, NA, SD, SL, SZ, TZ, UG, ZM, ZW), Eurasian (AM, AZ, BY, KG, KZ, MD, RU, TJ, TM), European (AL, AT, BE, BG, CH, CY, CZ, DE, DK, EE, ES, FI, FR, GB, GR, HR, HU, IE, IS, IT, LT, LU, LV, MC, MK, MT, NL, NO, PL, PT, RO, SE, SI, SK, SM, TR), OAPI (BF, BJ, CF, CG, CI, CM, GA, GN, GQ, GW, ML, MR, NE, SN, TD, TG).

Published:

— with international search report (Art. 21(3))



(54) Title: REFLECTANCE AND/OR TRANSMISSIVE PULSE OXIMETER

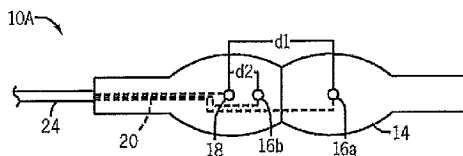

FIG. 1

(57) Abstract: According to various embodiments, a medical sensor assembly (10a, 10b) may be configured to switch between transmission and reflectance mode. Such sensors may include multiple optical emitting components (16, 16a, 16b) and sensing components (18, 18a, 18b) that may be activated or silent, depending on the mode in use. A practitioner may switch between modes based on the particular situation of the patient or based on the signal quality.

WO 2011/008382 A1

REFLECTANCE AND/OR TRANSMISSIVE PULSE OXIMETER

BACKGROUND

The present disclosure relates generally to medical devices and, more particularly, to sensors used for sensing physiological parameters of a patient.

This section is intended to introduce the reader to aspects of the art that may be related to various aspects of the present disclosure, which are described and/or claimed below. This discussion is believed to be helpful in providing the reader with background information to facilitate a better understanding of the various aspects of the present disclosure. Accordingly, it should be understood that these statements are to be read in this light, and not as admissions of prior art.

In the field of medicine, doctors often desire to monitor certain physiological characteristics of their patients. Accordingly, a wide variety of devices have been developed for monitoring many such physiological characteristics. Such devices provide doctors and other healthcare personnel with the information they need to provide the best possible healthcare for their patients. As a result, such monitoring devices have become an indispensable part of modern medicine.

One technique for monitoring certain physiological characteristics of a patient is commonly referred to as pulse oximetry, and the devices built based upon pulse oximetry techniques are commonly referred to as pulse oximeters. Pulse oximetry may be used to measure various blood flow characteristics, such as the blood-oxygen saturation of hemoglobin in arterial blood, the volume of individual blood pulsations supplying the tissue, and/or the rate of blood pulsations corresponding to each heartbeat of a patient. In fact, the "pulse" in pulse oximetry refers to the time varying amount of arterial blood in the tissue during each cardiac cycle.

Pulse oximeters typically utilize a non-invasive sensor that transmits light through a patient's tissue and that photoelectrically detects the absorption and/or

scattering of the transmitted light in such tissue. One or more of the above physiological characteristics may then be calculated based upon the amount of light absorbed and/or scattered. More specifically, the light passed through the tissue is typically selected to be of one or more wavelengths that may be absorbed and/or scattered by the blood in an amount correlative to the amount of the blood constituent present in the blood. The amount of light absorbed and/or scattered may then be used to estimate the amount of blood constituent in the tissue using various algorithms.

Pulse oximetry sensors may be applied to a patient's tissue site and secured, for example by adhesives, clips, or light pressure, to achieve a conforming fit. Some outside light infiltration into the sensor may be avoided by fitting the sensor snugly against the patient's tissue. However, such a conforming fit may be difficult to achieve over a range of patient physiologies without adjustment or excessive attention on the part of medical personnel. Further, patient movement may also interfere with the signal received from the sensor. For example, for the case a bandage-type sensor wrapped around the fingertip, if the finger is bent at a first joint, parts of the sensor may fold or buckle away from the tissue. Such small changes in the conformation of the sensor may cause the optical components to lose their contact with the skin, resulting in changes to the emitted and/or detected light, which in turn may lead to signal artifacts. While these artifacts may sometimes be addressed by signal processing and filtering to mitigate the effects, such signal processing may be complex.

BRIEF DESCRIPTION OF THE DRAWINGS

Advantages of the disclosure may become apparent upon reading the following detailed description and upon reference to the drawings in which:

Fig. 1 is a perspective view of a dual-mode bandage-style sensor with two emitters according to an embodiment;

Fig. 2A is a side view of the sensor of Fig. 1 applied to a patient's digit and operating in transmission mode according to an embodiment;

Fig. 2B is a side view of the sensor of Fig. 1 applied to a patient's digit and operating in reflectance mode according to an embodiment;

Fig. 3 is a side view of a dual-mode sensor with two detectors operating in reflectance mode and transmission mode simultaneously according to an
5 embodiment;

Fig. 4 is a flow diagram of a method of selecting between transmission mode or reflectance mode for a two emitter sensor according to an embodiment;

Fig. 5 is a flow diagram of a method of selecting between transmission mode or reflectance mode for a two detector sensor according to an embodiment;

10 Fig. 6 illustrates a pulse oximetry system coupled to a multi-parameter patient monitor and a sensor according to an embodiment;

Fig. 7 is a block diagram of a pulse oximetry system according to an embodiment;

15 Fig. 8 is a block diagram of a dual-mode sensor with two emitters and a control on the monitor for switching between the two emitters according to an embodiment;

Fig. 9 is a block diagram of a dual-mode sensor with two emitters and a control on the sensor for switching between the two emitters according to an embodiment;

20 Fig. 10 is a block diagram of a dual-mode sensor with two emitters and a control on the monitor for activating each emitter according to an embodiment;

Fig. 11 is a block diagram of a dual-mode sensor with two emitters and a control on the sensor for activating each emitter according to an embodiment; and

25 Fig. 12 is a block diagram of a dual-mode sensor with two detectors according to an embodiment.

DETAILED DESCRIPTION OF SPECIFIC EMBODIMENTS

One or more specific embodiments of the present techniques will be described below. In an effort to provide a concise description of these embodiments, not all features of an actual implementation are described in the specification. It should be appreciated that in the development of any such actual implementation, as in any engineering or design project, numerous implementation-specific decisions must be made to achieve the developers' specific goals, such as compliance with system-related and business-related constraints, which may vary from one implementation to another. Moreover, it should be appreciated that such a development effort might be complex and time consuming, but would nevertheless be a routine undertaking of design, fabrication, and manufacture for those of ordinary skill having the benefit of this disclosure.

Medical sensors such as pulse oximetry sensors may be placed on a patient in a location that is normally perfused with arterial blood to facilitate measurement of the desired blood characteristics, such as arterial oxygen saturation measurement (SpO₂). For example, common sensor sites include a patient's fingertips, toes, earlobes, or forehead. In addition, pulse oximetry sensors may be capable of performing intrauterine measurements. Sensors in either reflectance-type or transmission-type configurations (or, in certain cases, transreflectance-type configurations) may be able to sense light that has been transmitted through the tissue.

Sensors as provided herein may be able to operate in both "transmission mode" and "reflectance mode." Transmission mode sensors include an emitter and detector that are typically placed on opposing sides of the sensor site. If the sensor site is a fingertip, for example, the sensor assembly is positioned over the patient's fingertip such that the emitter and detector lie on either side of the patient's nail bed. In other words, the sensor assembly is positioned so that the emitter is located on the patient's fingernail and the detector is located approximately 180° opposite the emitter on the patient's finger pad. During operation, the emitter shines one or more wavelengths of light through the patient's fingertip and the light received by the detector is processed to determine various physiological characteristics of the

patient. In each of the embodiments discussed herein, it should be understood that the locations of the emitter and the detector may be exchanged. For example, the detector may be located at the top of the finger and the emitter may be located underneath the finger. In either arrangement, the sensor assembly will perform in
5 substantially the same manner.

Reflectance mode sensors also operate by emitting light into the tissue and detecting the light that is transmitted and/or scattered by the tissue. However, reflectance type sensors include an emitter and detector that are typically placed on the same side of the sensor site. For example, a reflectance type sensor may be
10 placed on a patient's fingertip or forehead such that the emitter and detector lie side-by-side. Reflectance type sensors detect light photons that are scattered back to the detector. Sensor assemblies may also be "transflectance," such as a sensor that may subtend a portion of a baby's heel.

Regardless of the placement of a sensor used for pulse oximetry, the
15 reliability of the pulse oximetry measurement is related to the accurate detection of transmitted light that has passed through the perfused tissue and that has not been supplemented by undesired light sources or that has not been scattered or redirected before passing through the tissue and being detected. In addition, the reliability of the measurements may be affected by appropriate calibration of the received sensor
20 signals to account for properties of the sensor and/or the sensing components. For example, reflectance-type sensors may be calibrated to account for the distance between the emitter and the detector on the sensor, which may influence the path length of the detected light. Transmission-type sensors may be calibrated to account for an estimated path length that reflects the width of the intended
25 measurement site, such as a finger or an ear lobe. Accordingly, because sensors may be specifically calibrated for transmission use versus reflectance use, the quality of a sensor's measurements may be degraded if a transmission-type sensor is inadvertently used in a reflectance-type configuration.

As disclosed herein, sensors for pulse oximetry or other applications
30 utilizing spectrophotometry are provided that may be capable of being used in both reflectance mode and transmission mode. Such sensors may provide distinct

advantages for healthcare practitioners. Upon a decrease in signal quality, such dual-mode sensors may switch from reflectance mode to transmission mode or vice versa to improve the measured signal quality. For example, when a patient wearing a digit sensor taps a finger on a hard surface, the resultant signal artifacts may influence the signal from a reflectance mode sensor more profoundly, particularly if both the emitter and the detector, which are side-by-side, are directly tapped against the surface. By switching to transmission mode and activating a different detector on the opposing side of the sensor, the influence of the tapping motion on the signal may be decreased because, while the original emitter may still be directly affected by the tapping, the different detector on the opposing side of the sensor may be relatively shielded from the tapping motion. Further, switching modes may allow practitioners to sample different areas of the tissue to determine if a particular mode offers increased signal quality. For example, relatively small areas of tissue discoloration or low perfusion may be avoided by sampling both transmission mode and reflectance mode signal quality and selecting the highest quality signal.

Fig. 1 illustrates an example of a dual-mode bandage-type sensor **10A** appropriate for use on a patient's digit. The sensor body **14** includes a transmission mode emitter **16a**/detector **18** pair disposed on its surface. In addition, the sensor **10A** also includes a second emitter **16b**, which may pair with detector **18** in a reflectance mode arrangement. The sensor body **14** may include suitable electrical connectors, such as wire leads **20**, that may operatively connect the emitters **16a** and **16b** and the detector **18** to a cable **24**, which may be connected to a downstream monitoring device. The sensor **10A** may also include an adhesive layer (not shown) in order to enhance the sensor's fit to the tissue.

The emitter **16a** and detector **18** may be spaced apart on the sensor body **14** any suitable distance d_1 for a transmission-type arrangement. For example, the appropriate spacing d_1 may be 20-25mm apart. In addition, the emitter **16b** and the detector **18** may be spaced apart any suitable distance d_2 for a reflectance-type arrangement. In one embodiment, the distance d_2 may be 8-14mm. As shown, emitter **16b** is disposed between **16a** and **18**. However, it should be understood

that emitter **16b** may be located anywhere on the sensor body **14** such that the distance d_2 and configuration (e.g., the spacing and placement on the tissue) between **16b** and **18** is appropriate for reflectance mode measurements.

Figs. 2A and **2B** depict the sensor **10A** applied to a patient's digit. **Fig. 2A** is a side view of sensor **10A** operating in transmission mode, during which emitter **16a** is active and emitter **16b** is inactive. The light, depicted by arrow **26**, emitted by emitter **16a** travels through the tissue and is detected by detector **18**. In **Fig. 2B**, the sensor **10A** is shown operating in reflectance mode. In reflectance mode, a monitor or other device activates emitter **16b** and not emitter **16a**. The light **28** from emitter **16b** is detected by the detector **18**. As shown, the emitter **16b** and the detector **18** may be arranged to be secured to the palmar side of the digit. Alternatively, the sensor **10A** may be applied to the digit such that the emitter **16b** and the detector **18** are secured to the nail side of the digit and the emitter **16a** is applied on the palmar side.

In an alternative arrangement, a sensor may include multiple detectors **18** and a single emitter **16**. As shown in **Fig. 3**, a sensor **10B** may include an emitter **16** and detector **18a** that are configured to operate in transmission mode in which light **30** from the emitter **16** travels through the tissue and encounters detector **18a**. A second detector **18b** may be configured to pair with emitter **16** in reflectance mode and detect light **32**. As shown, the transmission and reflectance modes may operate simultaneously. In other embodiments, the detectors **18a** and **18b** may be activated at different times.

As noted above, sensors **10** as provided herein may include one or more emitters paired with a single detector or one or more detectors paired with a single emitter. Regardless of the configuration of the optical sensing components, such sensors **10** may be able to switch between reflectance and transmission modes or, in embodiments, operate both modes simultaneously. As such, an upstream medical device may receive one signal from each emitter-detector pair or each "mode." These signals may be further processed to determine if a particular mode provides higher signal quality or is associated with fewer signal artifacts.

Fig. 4 is a flow diagram of a method **40** for processing sensor signals from both transmission and reflectance modes that may be used in conjunction with a sensor including multiple emitters, such as sensor **10A**. At step **42**, one of the two emitters **16** is activated, i.e., a drive signal is provided to the emitter from an

5 upstream device. For certain types of sensors **10**, a sensor may start out in a default mode, for example a transmission mode may be the default setting and the emitter **16a** may be activated while emitter **16b** is inactive. For other types of sensors **10**, an operator may manually select a starting mode for operation, which may depend on the tissue site to be measured or other patient factors. At step **44**, the signal

10 from the detector **18** is received, for example by the upstream device, for processing. At step **46**, any suitable processing method for determining signal quality may be employed to assess the quality of the received signal and to determine if the signal has attained a certain minimum threshold quality. In one embodiment, the signal quality may be assessed by performing a pulse qualification

15 on the signal. In other embodiments, the signal quality may be assessed by determining a ratio of ratios for the signal. Such signal quality assessments may be performed as provided in U.S. Patent No. 7,209,774, the specification of which is incorporated by reference herein in its entirety herein for all purposes. Other methods for determining signal quality may include detecting characteristic

20 artifacts associated with certain types of patient or sensor movement.

If the signal of the default mode is determined to be of sufficient quality, the signal may then be used at step **48** to determine blood oxygen characteristics (or other physiological parameters), such as pulse rate and blood oxygen saturation. However, if the signal quality falls below a certain threshold, the inactive emitter

25 **16**, representing the “non-default” mode, may be activated at step **50**. The signal from this emitter **16** may be received at step **46** and evaluated at step **48** for signal quality. If the signal quality from step **50** is above the threshold, then the sensor will continue to operate in the higher quality mode. If the signal quality from step **50** also falls below the quality threshold, then the device may prompt various alerts

30 or error messages. The process **40** may be repeated to continuously or periodically assess the signal quality of the mode in use.

While the above method **40** may allow for switching modes between transmission and reflectance (or vice versa) only when an active mode falls below a certain quality, a sensor **10A** may also provide alternating signals from both modes to an upstream device that may be continually arbitrated to determine the best quality signal, which may then be used to calculate blood oxygen characteristics.

Fig. 5 is a flow diagram of a method **60** that may be used in conjunction with a sensor with two emitters, such as sensor **10A**. At step **62**, emitters **16a** and **16b** are alternately activated, such that when one is active, the other is inactive. The alternate activation may be one the order of microseconds or seconds and may be accomplished by a light drive input signal from a medical device as well as additional inputs or controls located on the sensor **10A** and/or on the device, as discussed below (see **Figs. 10** and **11**). The upstream medical device may receive the alternating signal (i.e., a signal that includes information from both emitters **16a** and **16b**) from the detector **18** at step **64**. At step **66**, the signals may be decoupled into separate signals from each emitter **16a** and **16b**, for example using timing information from a light drive and time processing unit. Alternatively, the signals may be decoupled using intensity information. For example, transmission mode signals may be generally about half the amplitude of reflectance mode signals because of the greater distance between the transmission mode emitter-detector pair.

Regardless of how the signals from each emitter **16** are separated, the separated signals may then be further processed at step **68** to determine signal quality. As discussed above, signal quality metrics may be measures of artifact contribution, pulse qualification or of a ratio-of-ratios calculation. The higher quality signal may be used in step **70** to determine blood oxygen characteristics. The signals from each emitter **16** may be continuously arbitrated such that the higher quality signal within a predetermined time window may be used.

As noted above, in addition to sensor configurations with two emitters, sensors **10** may include a single emitter **16** and two detectors **18** that may form both transmission-type and reflectance-type emitter-detector pairs. **Fig. 6** is a flow diagram of a method **72** that may be used in conjunction with a sensor **10B**. At

step 74, one of the two detectors 18 is activated, i.e., the incoming signal is received and accessed for further processing at an upstream medical device. The sensor 10B may start out in a default mode, for example a transmission mode may be the default setting and the detector 18a may be activated while detector 18b is inactive, or the default mode may be input by an operator. At step 76, any suitable processing method for determining signal quality may be employed to assess the quality of the received signal from the active detector 18 and to determine if the signal has attained a certain minimum threshold quality. If the signal of the default mode is determined to be of sufficient quality, the signal may then be used at step 78 to determine blood oxygen characteristics. However, if the signal quality falls below a certain threshold, the inactive detector 18, representing the “non-default” mode, may be activated at step 80, and the signal from this detector may be further processed to determine its signal quality.

In one embodiment, a sensor 10B may operate transmission mode and reflectance mode simultaneously (see Fig. 3). In such an embodiment, detectors 18a and 18b may receive light concurrently from emitter 16. Fig. 7 is a flow diagram of a method 82 that may be used in conjunction with a sensor 10B during either simultaneous operation of both detectors 18a and 18b or, in embodiments, alternate operation of both detectors 18. At step 84, incoming signals from detectors 18a and 18b are received and accessed for further processing at an upstream medical device. Signal quality of both detector signals may be assessed by any suitable method at step 86 and the signal quality may be arbitrated. At step 88, the higher quality signal may be used to determine blood oxygen characteristics.

A sensor or sensor assembly, illustrated generically as a sensor assembly 10, may be used in conjunction with a pulse oximetry monitor 90, as illustrated in Fig. 8. It should be appreciated that the cable 24 of the sensor assembly 10 may be coupled to the monitor 90 or it may be coupled to a transmission device to facilitate wireless transmission between the sensor assembly 10 and the monitor 90. The monitor 90 may be any suitable pulse oximeter, such as those available from Nellcor Puritan Bennett LLC. Furthermore, to upgrade conventional pulse

oximetry provided by the monitor **90** to provide additional functions, the monitor **90** may be coupled to a multi-parameter patient monitor **92** via a cable **94** connected to a sensor input port or via a cable **96** connected to a digital communication port.

5 **Fig. 9** is a block diagram of an embodiment of a pulse oximeter **90** that may be configured to implement the embodiments of the present disclosure. Light from one or more emitters **16** may pass into a blood perfused tissue, and may be scattered, and then detected by one or more detectors **18**. An example of a sensor assembly **10** containing at least one emitter **16** and at least one detector **18** may also
10 contain an encoder **100** which may be capable of providing signals indicative of the wavelength(s) of light source **16** to allow the oximeter to select appropriate calibration coefficients for calculating oxygen saturation. The encoder **100** may, in an embodiment, be a resistor.

In an embodiment, the sensor assembly **10** may be connected to a pulse
15 oximetry monitor **90**. The monitor **90** may include a microprocessor **102** coupled to an internal bus **104**. Also connected to the bus may be a RAM memory **106** and a display **108**. A time processing unit (TPU) **110** may provide timing control signals to light drive circuitry **112**, which controls when the emitter **16** is activated, and if multiple light sources are used, the multiplexed timing for the different light
20 sources. TPU **114** may also control the gating-in of signals from detector **18** through an amplifier **116** and a switching circuit **118**. These signals are sampled at the proper time, depending at least in part upon which of multiple light sources is activated, if multiple light sources are used. The received signal from the detector **18** may be passed through an amplifier **124**, a low pass filter **128**, and an analog-to-
25 digital converter **130**. The digital data may then be stored in a queued serial module (QSM) **132**, for later downloading to RAM **106** or ROM **134** as QSM **132** fills up.

In an embodiment, based at least in part upon the received signals corresponding to the light received by detector **18**, microprocessor **102** may
30 calculate the oxygen saturation using various algorithms. These algorithms may

require coefficients, which may be empirically determined, and may correspond to the wavelengths of light used. The algorithms may be stored in a ROM 134 and accessed and operated according to microprocessor 102 instructions. For example, the encoder 100 may communicate with decoder 101 to allow the microprocessor
5 102 to determine the appropriate coefficients.

In an embodiment of a two-wavelength system, the particular set of coefficients chosen for any pair of wavelength spectra may be determined by a value indicated by the encoder 100 corresponding to a particular light source and particular emitter-detector separation distances in a particular sensor assembly 10.
10 In one embodiment, multiple resistor values may be assigned to select different sets of coefficients, or the sets of coefficients may be stored on a digital medium. In another embodiment, the resistors are used to select from among the coefficients appropriate for an infrared source paired with either a near red source or far red source. The selection between whether the near red or far red set will be chosen
15 can be selected with a control input from control inputs 136. Control inputs 136 may be, for instance, a switch on the pulse oximeter, a keyboard, or a port providing instructions from a remote host computer. Furthermore, any number of methods or algorithms may be used to determine a patient's pulse rate, oxygen saturation or any other desired physiological parameter.

20 The sensor assembly 10 includes at least one emitter 16 and at least one detector 18 that may be of any suitable type. For example, the emitter 16 may be one or more light emitting diodes adapted to transmit one or more wavelengths of light in the red to infrared range, and the detector 18 may one or more photodetectors selected to receive light in the range or ranges emitted from the
25 emitter 16. Alternatively, an emitter 16 may also be a laser diode or a vertical cavity surface emitting laser (VCSEL). An emitter 16 and detector 18 may also include optical fiber sensing elements. An emitter 16 may include a broadband or "white light" source, in which case the detector could include any of a variety of elements for selecting specific wavelengths, such as reflective or refractive
30 elements or interferometers. These kinds of emitters and/or detectors would typically be coupled to the rigid or rigidified sensor via fiber optics. Alternatively,

a sensor assembly **10** may sense light detected from the tissue is at a different wavelength from the light emitted into the tissue. Such sensors may be adapted to sense fluorescence, phosphorescence, Raman scattering, Rayleigh scattering and multi-photon events or photoacoustic effects.

5 For pulse oximetry applications, the oxygen saturation of the patient's arterial blood may be determined using two or more wavelengths of light, most commonly red and near infrared wavelengths. Similarly, in other applications, a tissue water fraction (or other body fluid related metric) or a concentration of one or more biochemical components in an aqueous environment may be measured
10 using two or more wavelengths of light, most commonly near infrared wavelengths between about 1,000 nm to about 2,500 nm. It should be understood that, as used herein, the term "light" may refer to one or more of ultrasound, radio, microwave, millimeter wave, infrared, visible, ultraviolet, gamma ray or X-ray electromagnetic radiation, and may also include any wavelength within the radio, microwave,
15 infrared, visible, ultraviolet, or X-ray spectra.

The emitter **16** and the detector **18** may be disposed on a sensor body, which may be made of any suitable material, such as plastic, foam, woven material, or paper. Alternatively, the emitter **16** and the detector **18** may be remotely located and optically coupled to the sensor assembly **10** using optical fibers. In the
20 depicted embodiments, the sensor assembly **10** is coupled to a cable **24** that is responsible for transmitting electrical and/or optical signals to and from the emitter **16** and detector **18** of the sensor assembly **10**. The cable may be permanently coupled to the sensor assembly **10**, or it may be removably coupled to the sensor assembly **10**-- the latter alternative being more useful and cost efficient in
25 situations where the sensor assembly **10** is disposable.

Depending on the particular configuration of the sensor **10**, the sensor **10** and/or the monitor **90** may include certain devices for controlling the activation of either two separate emitters **16** or two separate detectors **18**. As shown in **Fig. 10**, a monitor **90** may provide an input signal **142** to a switch **140** that controls
30 switching between emitter **16a** and emitter **16b**. As shown, switch **140** may be a hardware switch located on the sensor **10**. In other embodiments, the switch **140**

may be associated with cable **20** or may be located in the monitor **90**. The input signal **142** may be generated by light drive **112** and, as shown, may be an alternating signal **144** that causes the sensor **10** to periodically switch between emitter **16a** and emitter **16b**. It should be understood that the shape of signal **144** may be changed as desired or according to various inputs from microprocessor **102** (e.g., signal quality inputs) to provide different activation times for each emitter **16**. For example, the signal **144** may activate only emitter **16a** or only emitter **16b** until signal quality from the active emitter **16** deteriorates. Light drive **112** may also generate a drive signal **146** to alternately drive a red and IR photodiode pair for the active emitter **16**. The detector signal **148** includes both the red and IR components from the active emitter **16**. When emitter **16a** and emitter **16b** are alternately activated, the detector signal **148** received at switch **118** may include a Red_R portion (red reflectance), an IR_R portion (IR reflectance), a Red_T portion (red transmission) and an IR_T portion (IR transmission). Input from the time processing unit **110** may be used to assign parts of the signal to the appropriate emitter-detector pair (e.g., reflectance or transmission).

In an alternate configuration, shown in **Fig. 11**, an input signal **152** to the switch **140** may be controlled by a controller **152**, which may be located on the sensor **10**. Controller **152** may receive inputs from emitter **16a** and emitter **16b**. Regardless of whether the control for the switch **140** is generated by the monitor **90** or the sensor **10**, the red and IR diodes on each emitter **16** may further be controlled by light drive **112** and drive signal **146**. The detector signal **148** includes both the red and IR components from the active emitter **16**. In such a configuration, the sensor **10** may be adapted to work with off-the-shelf monitors **90**, which may not need to include addition hardware or software instructions for controlling the switch between emitters **16a** and **16b**.

For sensor configurations in which two detectors **18** are employed, the signals from each detector **18a** and **18b** may be processed within the monitor **90**. As shown in **Fig. 12**, light drive **112** may drive a single emitter **16** with drive signal **146**. When the light from the emitter **16** impinges the detectors **18a** and **18b**, the detector **18a** generates a transmission mode signal **160** that includes alternating

Red_T portions and IR_T portions while the detector **18b** generates a reflectance mode signal that includes alternating Red_R portions and IR_R portions. These signals may be passes through one or more amplifiers **116** and received at switch **118** for further processing by microprocessor **102**. For embodiments in which the signal
5 from one detector **18** is to be disregarded or considered inactive, for example when a particular mode is associated with low signal quality, the monitor **90** may not use the received signal from the inactive time window. Time processing unit **110** may provide time stamps to the received signals to determine the inactive and active time windows for each detector **18**.

10 Microprocessor **102** may employ various algorithms and signal processing methods to detect and/or mitigate various types of signal artifacts associated with one or more emitter-detector pairs from transmission mode and/or reflectance mode measurements. Such signal artifacts may be the result of periodic and aperiodic movement of the sensor or sensor site within the frequency band pass of
15 the monitor **90**, which may cause time-varying photocurrents that may obscure, corrupt, or overwhelm the arterial blood pulsations. Certain types of signal processing techniques may be employed to overcome certain types of signal artifacts, which may one or more of (1) η -artifacts, (2) α -artifacts, (3) ΔP_{tiss} -artifact, (4) heterogeneity artifacts, and (5) boundary condition artifacts. In addition, when
20 such signal artifacts are detected, the sensor **10** may automatically switch from the active mode (e.g., transmission or reflectance) to the inactive mode to determine if the signal artifact effects are mitigated by the switch.

1. η -artifacts

25 The η -artifacts (light coupling efficiency variations with time) may be related to a variation in light amplitude as a result of sensor movement relative to the tissue, the amount of light that reaches the skin, or the amount of light that strikes the photodetector. There may or may not be symmetry in the amount of the artifact between IR and red signals, depending on the source of the variation. In one embodiment, the artifact may be at least in part the result of Fresnel coupling
30 changes, which may be related to variations in the index of refraction of the emitter, the skin, any air gap between the sensor and the sensor site, and any

adhesive used. Further, as the emitter **16** and detector **18** move relative to the surface of the skin, these air gaps may open, close, or otherwise change. The resulting “Fresnel variations” in the light coupling may be as large as or larger than the magnitude of the plethysmographic signal. Accordingly, switching or
5 arbitrating between transmission and reflectance modes may mitigate some effects of geometric changes to the sensor **10** because not all movements affect the sensor geometry symmetrically. Certain types of movements may result in larger artifacts for one mode versus another. For example, an air gap between a sensor surface and a tissue site may be localized around the transmission emitter **16a** and may have
10 less of an effect on the reflectance emitter **16b**.

In addition to Fresnel coupling variations, z-axis variation may be the result of changes in the geometry of the emitter **16** relative to the skin, which may result in some of the light shunting around the skin and bouncing off of another surface. The total power of the light emitted into the tissue bed may vary with the
15 geometry of the emitter **16**. Further, the geometry of the detector may also result in similar variation.

As the physical separation between the emitter **16** and the detector **18** changes, the amount of light captured by the detector varies. This is due, in part, to the varying amount of tissue the light traverses. In general, the farther apart the
20 spacing, the less light detected. Thus, modulating the emitter-detector spacing may result in signal artifacts. In sensors **10** as provided, a switch to transmission mode, in which the spacing is farther apart, from reflectance mode, in which the spacing is relatively closer, may mitigate the effects of such modulation. In transmission mode, because the emitter and detector are farther apart, any change in distance
25 may be a smaller percentage of the emitter-detector spacing, thus the artifact may be a smaller contribution to the signal. However, depending on the type of movement, reflectance mode configurations may have improved signal quality because of relatively higher signal amplitude. Further, anti- η -artifacts may result when the emitter tilts on the red-IR axis such that the varying emitter-to-skin
30 spacing is not equal for both of the emitter pairs (e.g., the red LED and the IR LED

for a light emitting diode pair). This may result in as much as a 180° phase shift of the red and IR plethysmographic signals if the tilting is asymmetric.

2. α -artifacts

The α -artifacts (e.g., blood sloshing) may be related to variation in blood flow dynamics. When subjected to acceleration or a change in acceleration, the blood in the tissue will tend to resist this change due to its mass and will move to the down-hill side of the tissue. Since the degree of light absorption within the tissue bed is a function of the amount of absorber present, the shifting blood volume results in changes in the detected light level. Venous blood dominates these changes, but is not solely responsible. Such changes may occur independently of sensor adhesion factors. For example, moving a digit up and down may cause blood volume changes related to gravity. When the movement stops, there may be a time delay (e.g., the “blood slosh” settling back into position) associated with establishing a new DC level. Instead of waiting for the signal to settle into a new DC level, these types of artifacts may be mitigated by switching modes during the time delay.

3. ΔP_{tiss} -artifacts

The ΔP_{tiss} -artifacts (e.g., changes in applied forces) may be the result of pressure applied to the tissue that results in localized blood redistribution to neighboring regions where the pressure is lower. Pressing or bending the tissue may result in movement of blood, movement of subcutaneous structures, changes in relative position of subcutaneous structures, changes in scattering properties of compressible portions of the tissue, changes in coupling efficiency (e.g., Fresnel coupling changes), and a varying degree of shunting. Thus, pressing on or near the sensor 10 may result in changes to the detected light levels. Also include in this category of artifacts may be the effect of sensor deformation caused by the pressure changes. For example, bending a digit at the joint may cause changes in skin color, which are related to local pressure changes. Further, such changes in tissue shape may also influence shunting that occurs at the level below the epidermis. Such changes may effect certain areas of the tissue more profoundly. For example,

bending at a joint may cause localized exsanguination on the palmar side of the digit while causing an increase in redness on the side of the digit. Depending on the location of various emitters **16** and detectors **18** associated with transmission mode or reflectance mode, switching modes during a bending, pressing, or flexing motion may provide a higher quality signal.

4. Heterogeneity artifacts

In both reflectance and transmission sensor geometries, the probing light passes through several types of tissues, depending on where the sensor is located: dermis, fat, muscle, tendon, bone, vessels, etc. Each of these different tissues uniquely affect the way in which light passes, as they each have their own scattering and absorbing properties. If movement of the sensor sites causes these structures to move relative to the sensor, the detected light levels will change. Absorption and scattering properties are wavelength dependent, thus the magnitude of these changes will not be the same in the red and IR channels. Such heterogeneity artifacts may include xy-axis sensor movement (movement of the sensor that causes the light to strike different areas of the tissue) and subcutaneous object motion (moving vessels and subcutaneous structures will modulate the light signals and may corrupt the plethysmographic signal. For sensors **10** as provided, switching modes may provide a sampling of signal quality through multiple paths. For certain patients, a particular mode may provide an optical path that is less subject to heterogeneity artifacts. For example, reflectance mode may involve an optical path that travels through fewer subcutaneous structures. Because these effects vary from patient to patient, arbitrating the signal quality between the modes at the time of application of the sensor **10** may allow the higher signal quality mode to be used.

5. Boundary Condition Artifacts

Boundary condition artifacts may encompass changes in light losses due to changes in shape of the finite boundaries of the tissue site. As the tissue bends, the surfaces may compress, stretch, fold, etc. Detected light that has travelled close to the surface will become more or less strongly attenuated as the surface geometry affects how much scatters out of the tissue. If a reflective surface is nearby, some of the light may be returned to the tissue and may or may not contribute to the overall signal, depending on where the light reenters the tissue. Secondary light modulation may occur when light exits the tissue outside of the aperture of the detector **18**. Some of this light may be reflected back into the tissue to eventually reach the detector **18**. If the efficiency of this process changes as a result of other artifacts, this may also influence the quality of the signal. Accordingly, switching to a second detector (e.g., detector **18b**) on a different area of the tissue may provide improved signal quality when a primary detector is experiencing boundary condition artifacts.

The below tables summarize the contribution of various types of motions to a particular type of artifact. Table **1** shows the artifact effects for a transmission-type digit sensor, Table **2** shows the artifact effects for a reflectance-type forehead sensor, and Table **3** shows the artifact effects for a STORM-type sensor (as provided in U.S. Patent Application No. 11/444,577 to Fein et al., the specification of which is incorporated by reference in its entirety herein for all purposes).

Type of Motion	$\Delta\alpha$	$\Delta\eta$	ΔP_{tiss}	boundaries	heterogeneity
Flexing	low	high	high	high	moderate
Scratching	low	high	high	low	low
Tapping	high	high	high	moderate	moderate
Squeezing/Pressing	low	high	high	moderate	moderate
Swinging	high	low	low	low	low
Rubbing	low	high	high	moderate	moderate

Table 1: Potential Effects of Different Sources of Artifact for a D-25 Digit Sensor

Type of Motion	$\Delta\alpha$	$\Delta\eta$	ΔP_{tiss}	boundaries	heterogeneity
Flexing	low	high	moderate	high	moderate
Scratching	–	–	–	–	–
Tapping	–	–	–	–	–
Squeezing/Pressing	low	high	high	low	low
Swinging	moderate	low	low	low	low
Rubbing	low	high	high	moderate	moderate

Table 2: Potential Effects of Different Sources of Artifact for a RS-10 Forehead Sensor

5

Type of Motion	$\Delta\alpha$	$\Delta\eta$	ΔP_{tiss}	boundaries	heterogeneity
Flexing	low	low	high	low	low
Scratching	low	low	high	low	low
Tapping	high	low	high	low	low
Squeezing/Pressing	low	low	high	low	low
Swinging	high	low	low	low	low
Rubbing	low	low	high	low	low

Table 3: Potential Effects of Different Sources of Artifact for a Storm 1 Sensor

Monitors **90** that utilize signal processing algorithms such as the STORM algorithm may be able to overcome the effects of various types of signal artifacts.

5 STORM sensors may include sensors designed to be used where “motion provides the signal”, i.e., the cardiac pulse need not be present or discernible in order for the oximeter to provide SpO₂ values. Instead, the red and IR waveforms resulting from the motion itself are used for determining the arterial saturation. This feature is possible for tissue beds that are well “arterialized” (a large supply of arterial blood

10 relative to the metabolic needs of the tissue) resulting in a small arterio-venous saturation difference, as well as other signal characteristics. It has been observed that the necessary degree of arterialization correlates well to being “well perfused” at the tissue site, which itself correlates well to the tissue bed being warm. Thus by monitoring the temperature of the skin at the sensor site, and by knowing a value of

15 temperature (programmed into the memory chip) at which the “motion-is-signal” algorithm can be utilized for the specific sensor design being used, improved reading accuracy through motion can be better accomplished.

In particular, such algorithms may be effective in overcoming boundary condition artifacts and heterogeneity-based artifacts. When such algorithms are

used in conjunction with sensors **10** that are able to switch from a reflectance-type configuration to a transmission-type configuration, or vice versa, the effects of certain types of artifacts may be further reduced. For example, certain types of ΔP_{tiss} artifacts may be less profound for reflectance-type configurations relative to transmission-type configurations. As such, sensors **10** as provided may include one or more temperature sensors configured to communicate with monitor **90** and provide temperature inputs to determine whether the STORM algorithm should be used to process the incoming signal from sensor **10**.

Further, signal quality metrics may be employed to determine if various types of signal artifacts are present in the incoming signal. For example, a tapping motion of a digit may present a characteristic signal artifact that may be identified by the monitor **90**. If such an artifact is identified, a sensor **10** may then automatically switch from a transmission mode to a reflectance mode. In other embodiments, bending or flexing of a tissue site may result in blood flow and skin discoloration changes that have a characteristic artifact effect. In such an embodiment, the sensor **10** may switch modes until the signal artifact is resolved.

While the disclosure may be susceptible to various modifications and alternative forms, specific embodiments have been shown by way of example in the drawings and have been described in detail herein. However, it should be understood that the embodiments provided herein are not intended to be limited to the particular forms disclosed. Indeed, the disclosed embodiments may not only be applied to measurements of blood oxygen saturation, but these techniques may also be utilized for the measurement and/or analysis of other blood constituents. For example, using the same, different, or additional wavelengths, the present techniques may be utilized for the measurement and/or analysis of carboxyhemoglobin, met-hemoglobin, total hemoglobin, fractional hemoglobin, intravascular dyes, and/or water content. Rather, the various embodiments may cover all modifications, equivalents, and alternatives falling within the spirit and scope of the disclosure as defined by the following appended claims.

CLAIMS

What is claimed is:

1. A sensor comprising:
a sensor body adapted to be applied to a patient's tissue;
5 a first emitter and a second emitter disposed on the sensor body; and
a detector disposed on the sensor body, wherein the first emitter and the
detector are capable of operating in transmission mode and the second emitter and
the detector are capable of operating in reflectance mode, and wherein the sensor is
capable of alternating between transmission mode and reflectance mode.
- 10 2. The sensor, as set forth in claim 1, wherein the sensor comprises at
least one of a pulse oximetry sensor or a sensor for measuring a water fraction.
3. The sensor, as set forth in claim 1, wherein first emitter or the second
emitter comprises at least one light emitting diode and wherein the detector
comprises at least one photodetector.
- 15 4. The sensor, as set forth in claim 1, comprising a default mode,
wherein the default mode is one of transmission mode or reflectance mode.
5. The sensor, as set forth in claim 1, wherein the first emitter and the
detector are spaced apart about 20mm to about 25mm or wherein the second emitter
and the detector are spaced apart about 8mm to about 14mm.
- 20 6. The sensor, as set forth in claim 1, comprising a controller for
controlling activation of the first emitter and the second emitter.
7. The sensor, as set forth in claim 6, wherein the controller is
configured to alternate between the first emitter and the second emitter.
8. The sensor, as set forth in claim 1, comprising an encoder, wherein
25 the encoder comprises stored data related to the sensor.
9. A sensor comprising:
a sensor body adapted to be applied to a patient's tissue;
a first detector and a second detector disposed on the sensor body; and
an emitter disposed on the sensor body, wherein the emitter and the first
30 detector are capable of operating in transmission mode and the emitter and the first
detector are capable of operating in reflectance mode, and wherein the sensor is
capable of alternating between transmission mode and reflectance mode.

10. The sensor, as set forth in claim 9, wherein the sensor comprises at least one of a pulse oximetry sensor or a sensor for measuring a water fraction.
11. The sensor, as set forth in claim 9, wherein emitter comprises at least one light emitting diode and wherein the first detector or the second detector
5 comprises at least one photodetector.
12. The sensor, as set forth in claim 9, comprising a default mode, wherein the default mode is one of transmission mode or reflectance mode.
13. The sensor, as set forth in claim 9, wherein the sensor is capable of
10 operating in transmission mode and reflectance mode simultaneously.
14. The sensor, as set forth in claim 9, wherein the emitter and the first detector are spaced apart about 20mm to about 25mm or wherein the emitter and the second detector are spaced apart about 8mm to about 14mm.
15. The sensor, as set forth in claim 9, comprising an encoder, wherein
15 the encoder comprises stored data related to the sensor.
16. A method comprising:
receiving a signal from a detector disposed on a sensor body;
determining a quality of the signal; and
switching between a first mode and a second mode if the signal quality is
20 below a certain threshold, wherein the first mode comprises a transmission mode and wherein the second mode comprises a reflectance mode.
17. The method, as set forth in claim 16, wherein switching from the first mode to the second mode comprises switching from a first emitter to a second emitter.
- 25 18. The method, as set forth in claim 16, wherein switching from the first mode to the second mode comprises switching from a first detector to a second detector.
19. The method, as set forth in claim 16, wherein determining a quality of the signal comprises determining if the signal comprises qualified pulses.
- 30 20. The method, as set forth in claim 16, wherein determining a quality of the signal comprises determining a ratio-of-ratios for the signal and determining if the ratio-of-ratios is characteristic of a high quality signal.

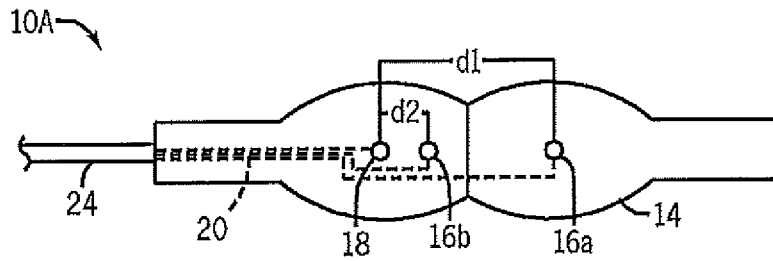

FIG. 1

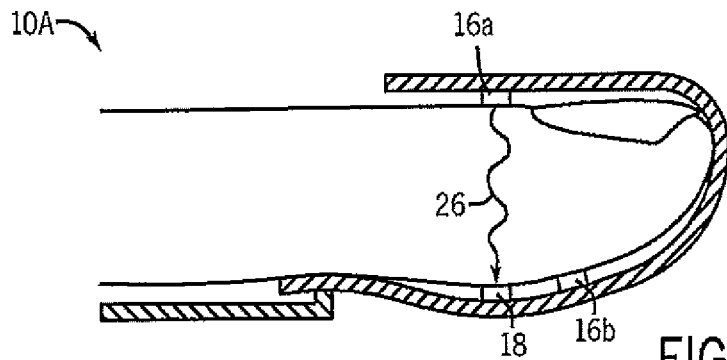

FIG. 2A

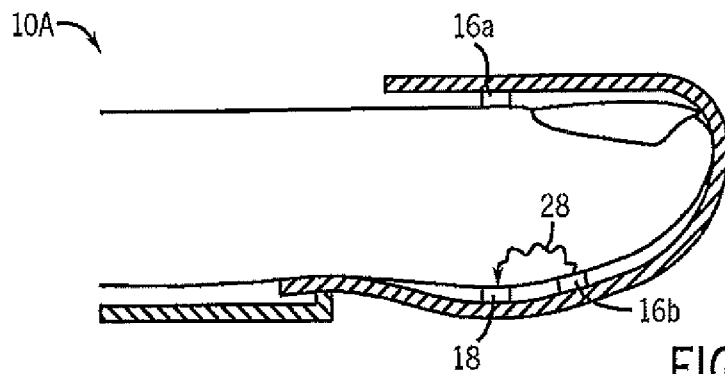

FIG. 2B

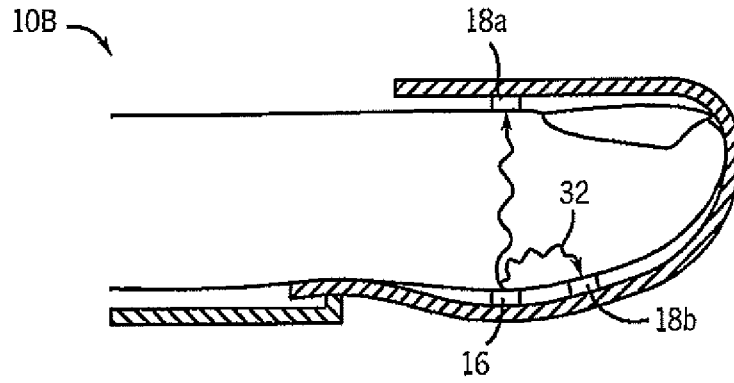

FIG. 3

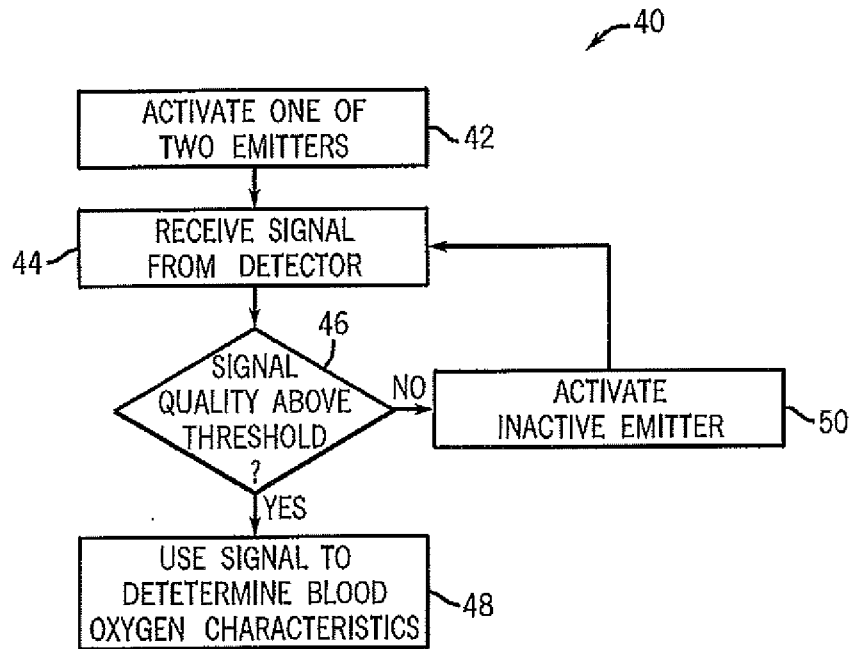
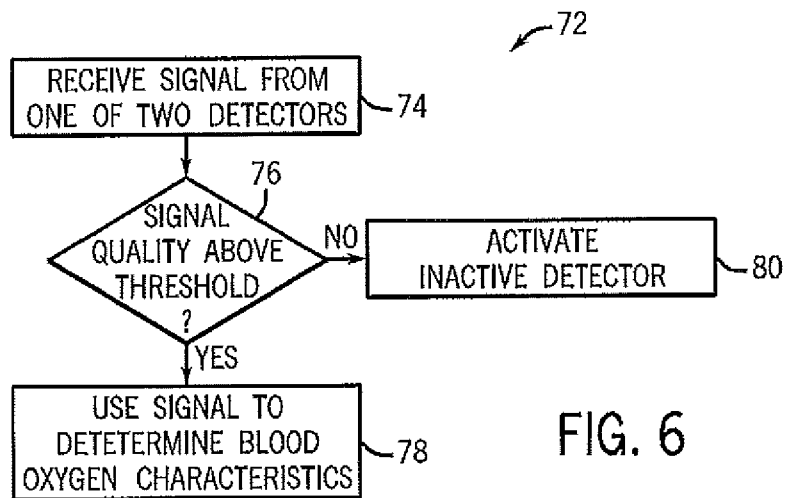
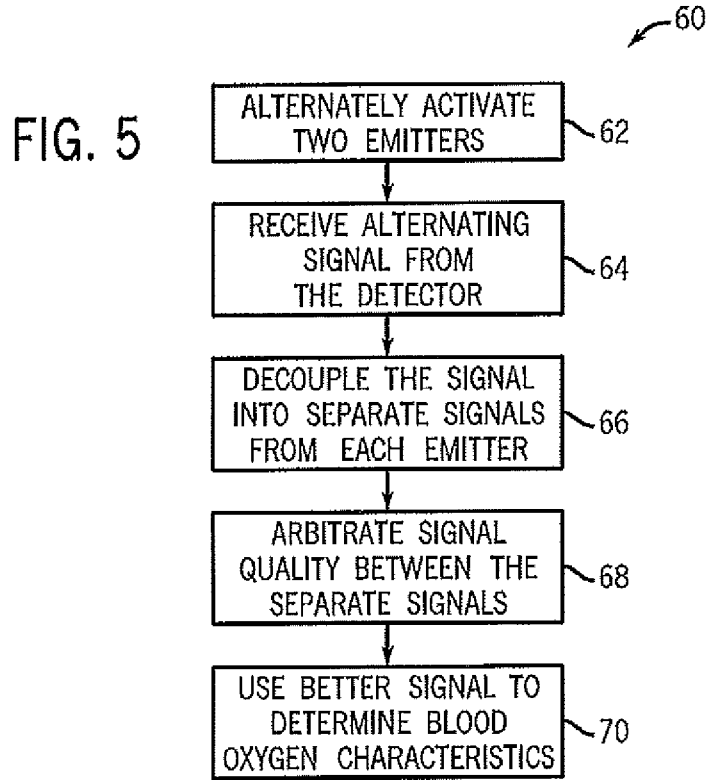

FIG. 4



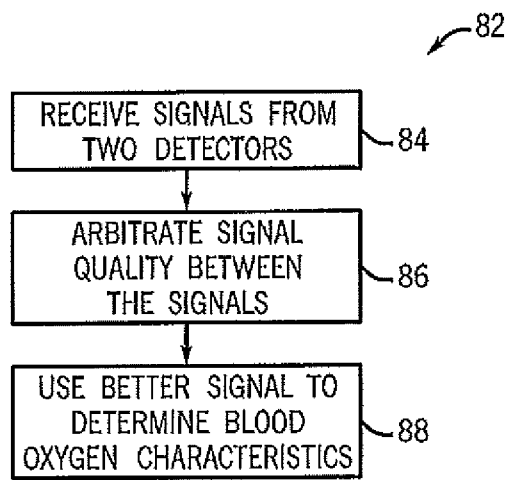

FIG. 7

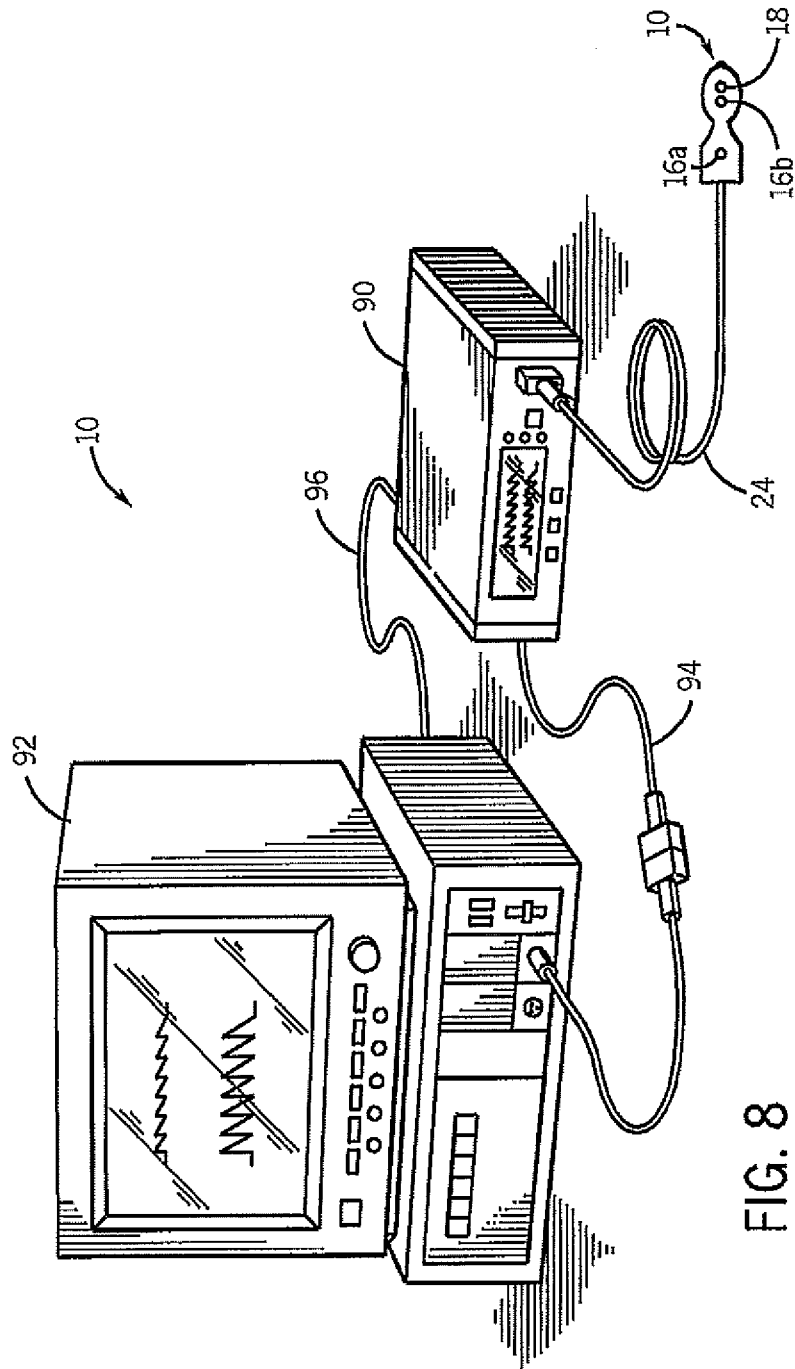

FIG. 8

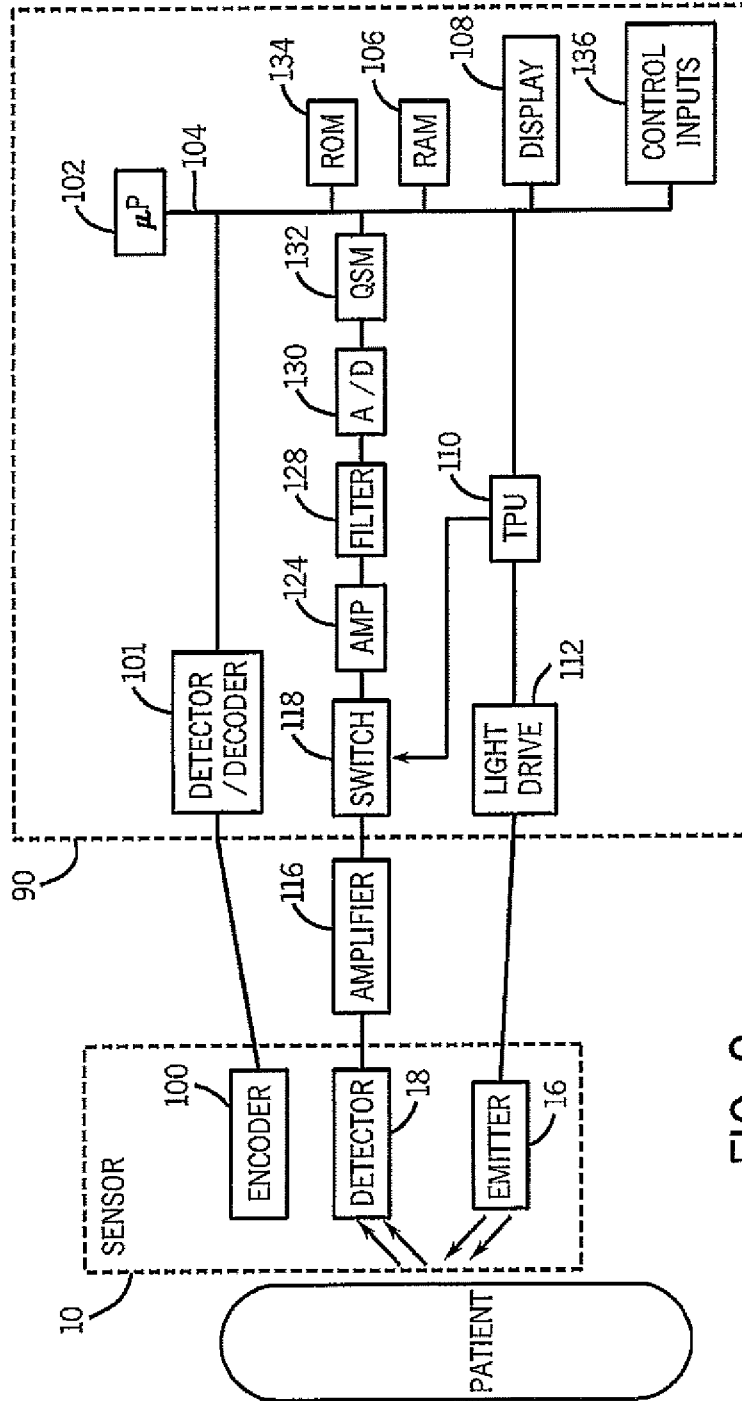

FIG. 9

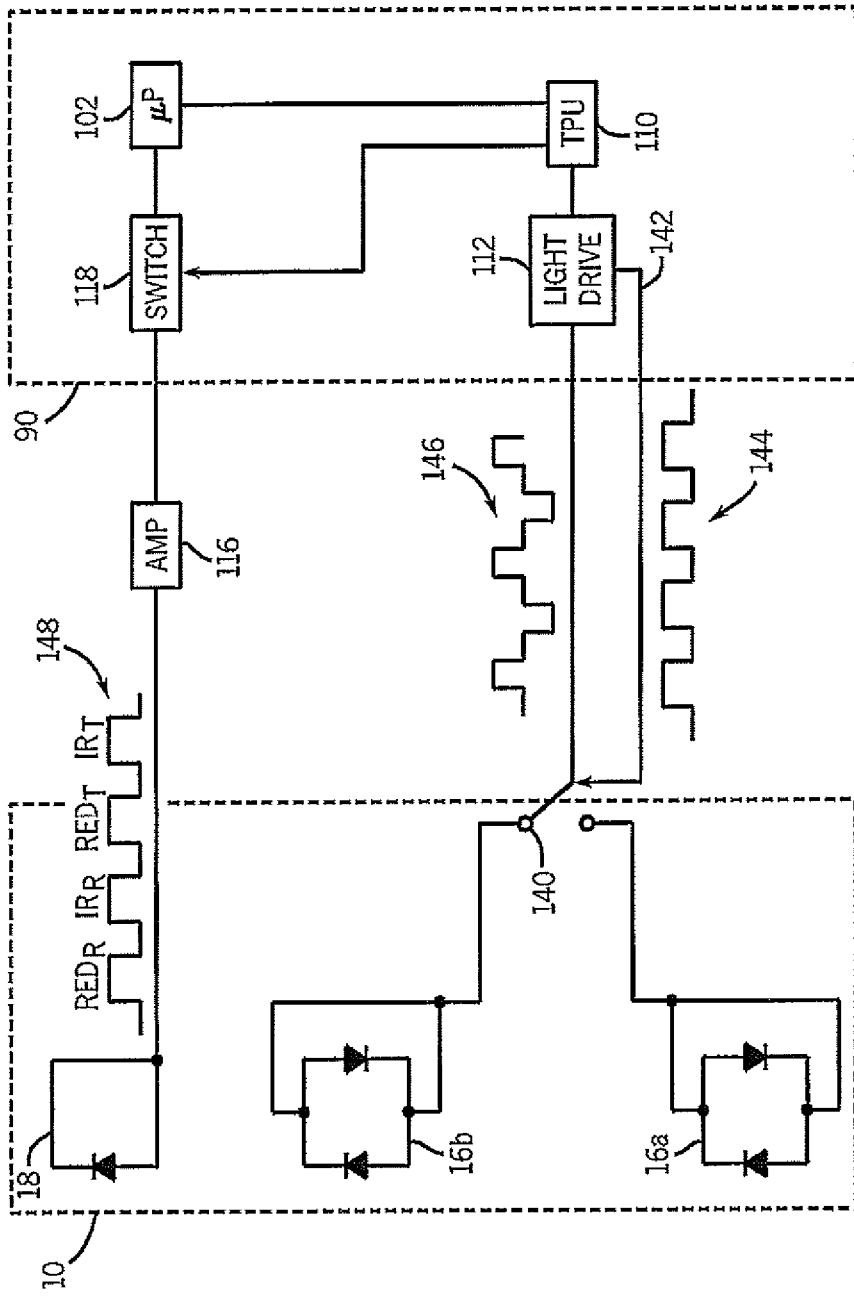

FIG. 10

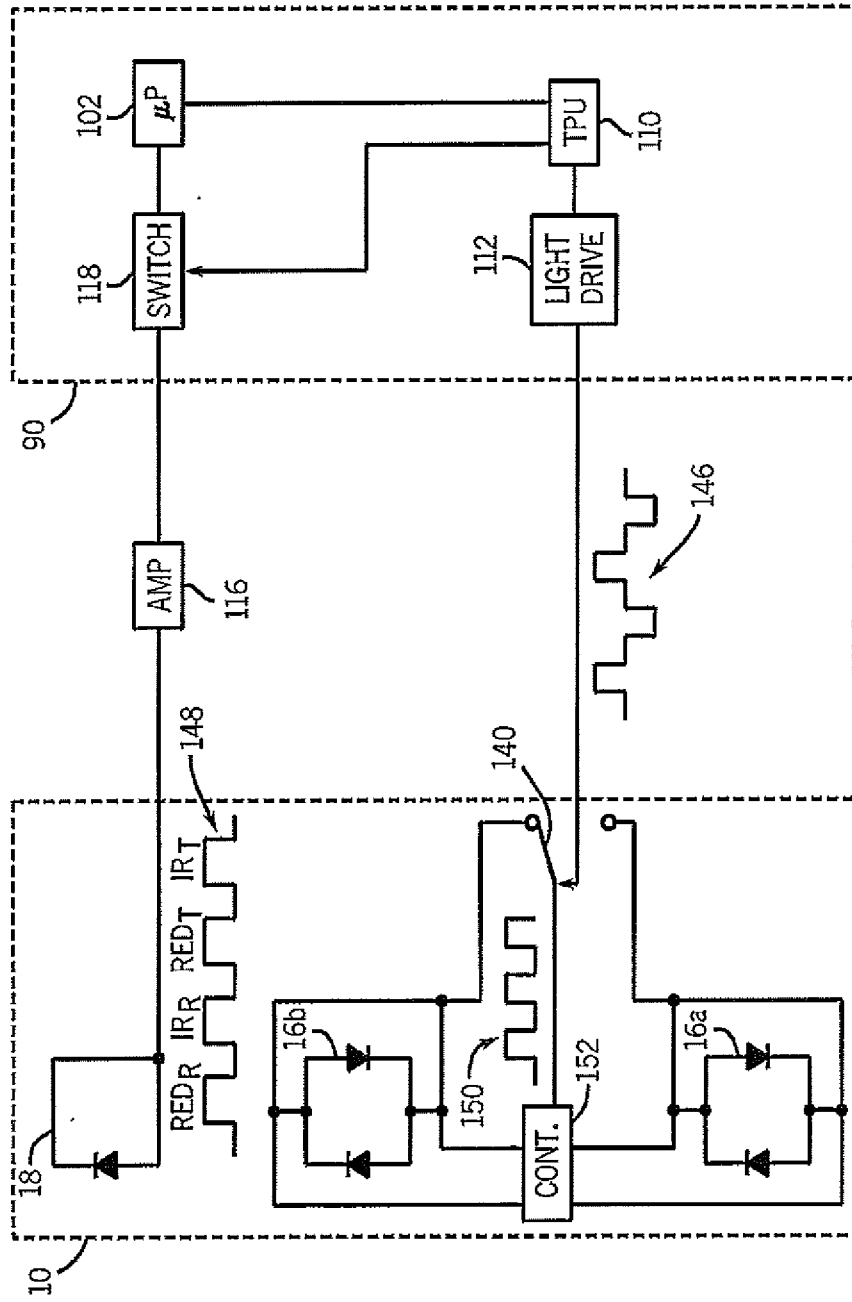

FIG. 11

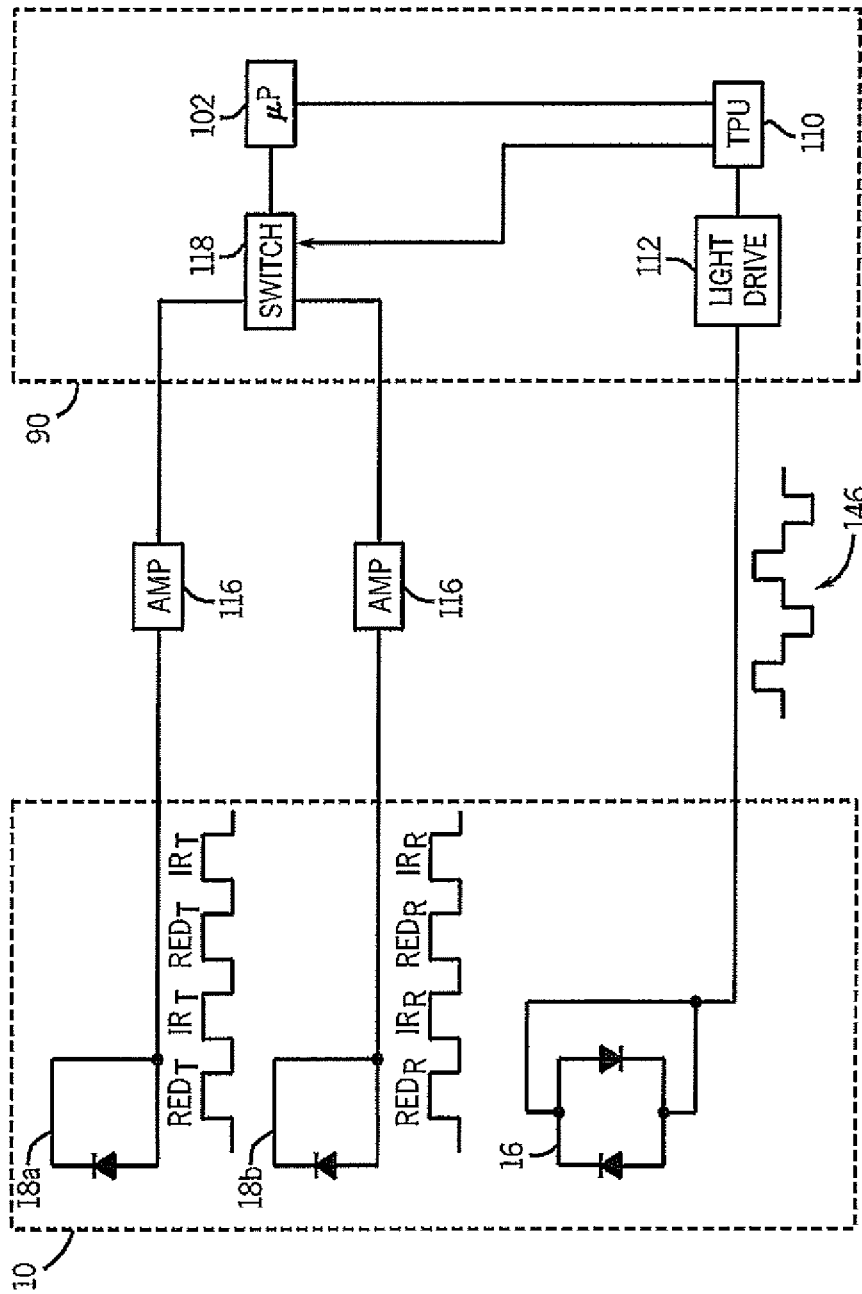

FIG. 12

INTERNATIONAL SEARCH REPORT

International application No

PCT/US2010/038105

A. CLASSIFICATION OF SUBJECT MATTER INV. A61B5/00 ADD.		
According to International Patent Classification (IPC) or to both national classification and IPC		
B. FIELDS SEARCHED		
Minimum documentation searched (classification system followed by classification symbols) A61B		
Documentation searched other than minimum documentation to the extent that such documents are included in the fields searched		
Electronic data base consulted during the international search (name of data base and, where practical, search terms used) EPO-Internal, WPI Data		
C. DOCUMENTS CONSIDERED TO BE RELEVANT		
Category*	Citation of document, with indication, where appropriate, of the relevant passages	Relevant to claim No.
X	WO 98/15224 A2 (NELLCOR PURITAN BENNETT INC [US]) 16 April 1998 (1998-04-16)	1-7, 9-14, 16-20
Y	page 9 - last paragraph page 10, paragraph 3 - paragraph 4 page 14, last paragraph - page 15, paragraph 1 page 17, paragraph 1 - page 18, paragraph 1 figures 4, 12, 17, 18	8,15
X	US 2009/054751 A1 (BABASHAN BRUCE [US] ET AL) 26 February 2009 (2009-02-26)	1-7, 9-14, 16-18
Y	paragraph [0094] - paragraph [0101] figures 8D-8F, 8H	8,15,19, 20
----- -/--		
<input checked="" type="checkbox"/> Further documents are listed in the continuation of Box C. <input checked="" type="checkbox"/> See patent family annex.		
* Special categories of cited documents :		
"A" document defining the general state of the art which is not considered to be of particular relevance "E" earlier document but published on or after the international filing date "L" document which may throw doubts on priority claim(s) or which is cited to establish the publication date of another citation or other special reason (as specified) "O" document referring to an oral disclosure, use, exhibition or other means "P" document published prior to the international filing date but later than the priority date claimed	"T" later document published after the international filing date or priority date and not in conflict with the application but cited to understand the principle or theory underlying the invention "X" document of particular relevance; the claimed invention cannot be considered novel or cannot be considered to involve an inventive step when the document is taken alone "Y" document of particular relevance; the claimed invention cannot be considered to involve an inventive step when the document is combined with one or more other such documents, such combination being obvious to a person skilled in the art. "&" document member of the same patent family	
Date of the actual completion of the international search	Date of mailing of the international search report	
15 October 2010	21/10/2010	
Name and mailing address of the ISA/ European Patent Office, P.B. 5818 Patentlaan 2 NL - 2280 HV Rijswijk Tel. (+31-70) 340-2040, Fax: (+31-70) 340-3016	Authorized officer Gärtner, Andreas	

INTERNATIONAL SEARCH REPORT

International application No
PCT/US2010/038105

C(Continuation). DOCUMENTS CONSIDERED TO BE RELEVANT		
Category*	Citation of document, with indication, where appropriate, of the relevant passages	Relevant to claim No.
X	US 2008/221413 A1 (HOARAU CARINE [US]) 11 September 2008 (2008-09-11)	9, 15
Y	paragraph [0047] - paragraph [0049] paragraph [0053] figures 9, 10, 15	8
Y	US 2007/100220 A1 (BAKER CLARK R JR [US]) 3 May 2007 (2007-05-03) paragraph [0020] paragraph [0080] paragraph [0092] - paragraph [0095] figures 1, 5, 6	8, 15, 19, 20
Y	US 2005/197793 A1 (BAKER CLARK R JR [US] BAKER JR CLARK R [US]) 8 September 2005 (2005-09-08) cited in the application paragraph [0029] - paragraph [0034]	19, 20
X	US 2006/009685 A1 (FINAROV ALEXANDER [IL] ET AL) 12 January 2006 (2006-01-12)	9-15
A	paragraph [0028] - paragraph [0029] paragraph [0038] figure 1	16-20
X	WO 96/37259 A1 (DOMJAN GYULA [HU]; GOEDOELLE LASZLO [HU]; GYARMATI LASZLO [HU]; JAKO J) 28 November 1996 (1996-11-28) figure 3 page 10, paragraph 2 - page 11, paragraph 1	9-13, 16, 18

INTERNATIONAL SEARCH REPORT

Information on patent family members

International application No PCT/US2010/038105

Patent document cited in search report	Publication date	Patent family member(s)	Publication date
WO 9815224	A2	16-04-1998	AT 257669 T 15-01-2004
			AU 4666397 A 05-05-1998
			CA 2267414 A1 16-04-1998
			DE 69727243 D1 19-02-2004
			DE 69727243 T2 04-11-2004
			EP 0951232 A2 27-10-1999
			JP 3950173 B2 25-07-2007
			JP 2001501847 T 13-02-2001
			US 6374129 B1 16-04-2002
			US 6018673 A 25-01-2000

US 2009054751	A1	26-02-2009	NONE

US 2008221413	A1	11-09-2008	WO 2008112210 A1 18-09-2008

US 2007100220	A1	03-05-2007	US 2009253971 A1 08-10-2009

US 2005197793	A1	08-09-2005	AT 466523 T 15-05-2010
			AU 2005221651 A1 22-09-2005
			CA 2557950 A1 22-09-2005
			CN 1933773 A 21-03-2007
			EP 1737337 A1 03-01-2007
			ES 2342945 T3 19-07-2010
			JP 2007527771 T 04-10-2007
			KR 20070004803 A 09-01-2007
			NZ 549512 A 31-10-2008
			US 2006195280 A1 31-08-2006
			WO 2005087094 A1 22-09-2005

US 2006009685	A1	12-01-2006	EP 1773183 A1 18-04-2007
			WO 2006006153 A1 19-01-2006

WO 9637259	A1	28-11-1996	AT 204185 T 15-09-2001
			AU 5842596 A 11-12-1996
			DE 69614528 D1 20-09-2001
			EP 0828533 A1 18-03-1998
			HU 216847 B 28-12-1999
			US 5974337 A 26-10-1999

专利名称(译)	反射和/或透射脉搏血氧仪		
公开(公告)号	EP2448466A1	公开(公告)日	2012-05-09
申请号	EP2010727299	申请日	2010-06-10
[标]申请(专利权)人(译)	内尔科尔普里坦贝内特公司		
申请(专利权)人(译)	NELLCOR PURITAN BENNETT LLC		
当前申请(专利权)人(译)	COVIDIEN LP		
[标]发明人	BESKO DAVID		
发明人	BESKO, DAVID		
IPC分类号	A61B5/00		
CPC分类号	A61B5/6826 A61B5/14552 A61B5/6838 A61B5/7207 A61B5/7221		
优先权	12/495551 2009-06-30 US		
外部链接	Espacenet		

摘要(译)

根据各种实施例，医疗传感器组件（10a，10b）可以被配置为在透射和反射模式之间切换。这种传感器可以包括多个光学发射部件（16,16a，16b）和可以被激活或静音的传感部件（18,18a，18b），这取决于使用的模式。从业者可以基于患者的特定情况或基于信号质量在模式之间切换。