

(19) World Intellectual Property Organization
International Bureau



(43) International Publication Date
29 April 2004 (29.04.2004)

PCT

(10) International Publication Number
WO 2004/034898 A2

(51) International Patent Classification⁷: **A61B 5/00**

Andreas [DE/DE]; c/o Philips Intellectual Property & Standards GmbH, Weissshausstr. 2, 52066 Aachen (DE).

(21) International Application Number:
PCT/IB2003/004354

(74) **Agent: VOLMER, Georg**; Philips Intellectual Property & Standards GmbH, Weissshausstr. 2, 52066 Aachen (DE).

(22) International Filing Date: 2 October 2003 (02.10.2003)

(81) **Designated States (national):** AE, AG, AL, AM, AT, AU, AZ, BA, BB, BG, BR, BY, BZ, CA, CH, CN, CO, CR, CU, CZ, DE, DK, DM, DZ, EC, EE, EG, ES, FI, GB, GD, GE, GH, GM, HR, HU, ID, IL, IN, IS, JP, KE, KG, KP, KR, KZ, LC, LK, LR, LS, LT, LU, LV, MA, MD, MG, MK, MN, MW, MX, MZ, NI, NO, NZ, OM, PG, PH, PL, PT, RO, RU, SC, SD, SE, SG, SK, SL, SY, TJ, TM, TN, TR, TT, TZ, UA, UG, US, UZ, VC, VN, YU, ZA, ZM, ZW.

(25) Filing Language: English

(26) Publication Language: English

(30) Priority Data:
102 47 984.4 15 October 2002 (15.10.2002) DE

(71) Applicant (for DE only): **PHILIPS INTELLECTUAL PROPERTY & STANDARDS GMBH** [DE/DE]; Stein-damm 94, 20099 Hamburg (DE).

(84) **Designated States (regional):** ARIPO patent (GH, GM, KE, LS, MW, MZ, SD, SL, SZ, TZ, UG, ZM, ZW), Eurasian patent (AM, AZ, BY, KG, KZ, MD, RU, TJ, TM), European patent (AT, BE, BG, CH, CY, CZ, DE, DK, EE, ES, FI, FR, GB, GR, HU, IE, IT, LU, MC, NL, PT, RO, SE, SI, SK, TR), OAPI patent (BF, BJ, CF, CG, CI, CM, GA, GN, GQ, GW, ML, MR, NE, SN, TD, TG).

(71) Applicant (for all designated States except DE, US): **KONINKLIJKE PHILIPS ELECTRONICS N.V.** [NL/NL]; Groenewoudseweg 1, NL-5621 BA Eindhoven (NL).

(72) Inventors; and

Published:
— without international search report and to be republished upon receipt of that report

(75) Inventors/Applicants (for US only): **NEUMANN, Rolf** [DE/DE]; c/o Philips Intellectual Property & Standards GmbH, Weissshausstr. 2, 52066 Aachen (DE). **BINDSZUS,**

[Continued on next page]

(54) Title: METHOD FOR THE PRESENTATION OF INFORMATION CONCERNING VARIATIONS OF THE PERFUSION

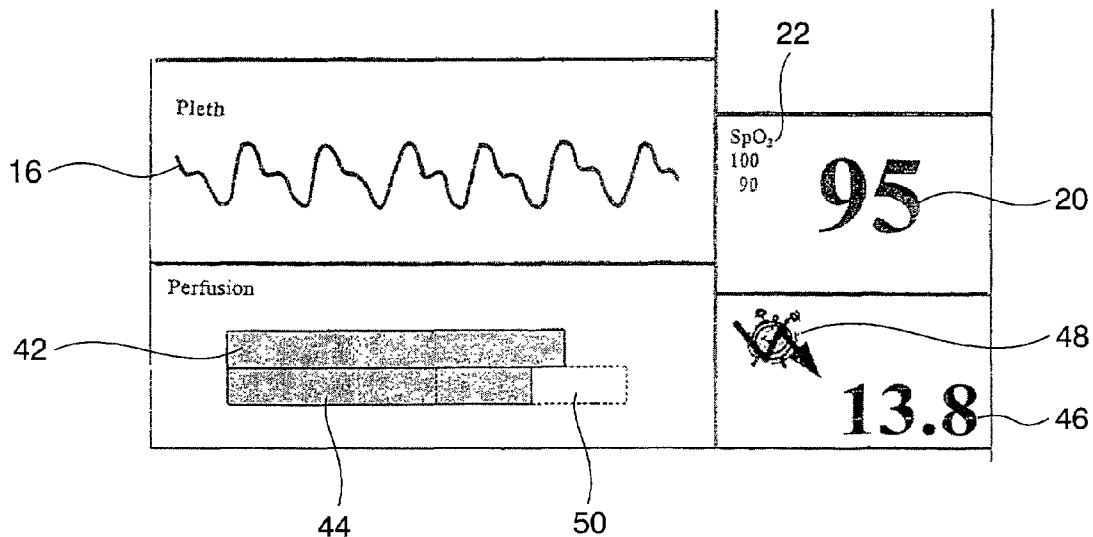

(57) **Abstract:** The invention relates to a method for the presentation of information concerning variations of the arterial filling with blood (perfusion) of organs of living beings on the user surface (10) of a display screen, in which method the data required for the presentation (perfusion index) is derived, using an algorithm, from measuring values of a non-invasive photometric measuring process for determining the arterial oxygen saturation of the blood. The invention is characterized in that a first perfusion index is defined as a reference value and the subsequent perfusion indices are determined as relative deviations with respect to the reference value, said relative deviations being presented in the form of analog, graphic elements (42, 44) on the user surface (10) as information concerning the 10 variations of the perfusion.

WO 2004/034898 A2



For two-letter codes and other abbreviations, refer to the "Guidance Notes on Codes and Abbreviations" appearing at the beginning of each regular issue of the PCT Gazette.

Method for the presentation of information concerning variations of the perfusion

The invention relates to a method for the presentation of information concerning variations of the perfusion as disclosed in claim 1, to a method for the presentation of the quality of the measuring values (signal quality) acquired during a photometric measuring process as claimed in the claims 16 to 18, and to a device for carrying
5 out the method as disclosed in claim 21.

As is known, in the field of patient monitoring special patient data such as, for example, perfusion, oxygen saturation of the arterial blood (SPO₂ value), ECG curves and the like are important for the evaluation of the condition of a patient.

Information as regards the perfusion can be derived only indirectly in normal
10 practice. To this end, the clinical staff can fall back on measuring values resulting from the measurement of the oxygen saturation of the arterial blood.

The measurement of the arterial oxygen saturation of the blood or the arterial hemoglobin is usually performed continuously in a non-invasive manner by means of a photometric measuring process, that is, the so-called pulsoximetry. A peripheral part of the
15 body, usually a finger, is then irradiated by means of a sensor. The sensor usually comprises two light sources for the emission of light and a corresponding photodetector for the measurement of the light absorption.

Pulsoximetry is based on two principles. On the one hand, the oxygen-enriched hemoglobin (oxyhemoglobin) and the oxygen-reduced hemoglobin
20 (desoxyhemoglobin) differ as regards their ability to absorb red and infrared light (spectrophotometry) and on the other hand the amount of arterial blood in the tissue changes, and hence also the absorption of light by this blood, during the pulse (plethysmography). A pulsoximeter determines the SPO₂ value by emitting red and infrared light and by measuring the variations of the light absorption during the pulse cycle.

25 Whereas the clinical staff is presented with the oxygen saturation of the blood, that is, the SPO₂ value, in the form of a numerical value, for information concerning the perfusion the staff has to take recourse to an interpretation of the plethysmography curve which is presented in the context of the pulsoximetry; this curve also shows inter alia the variation of the volume of a part of the body which is induced by the perfusion.

Because the perfusion is a clinically relevant parameter which is used, for example, to signal the changing of physiological factors, the effect of anesthesia or the like, this way of deriving information concerning the perfusion is found to be very detrimental.

On the one hand, the read-out accuracy is limited as the information has to be read from a curve which is not especially conceived for this purpose, meaning that this information has to be estimated, whereas on the other hand the amplification must be invariable for the presentation of the curve, making an evaluation of the shape of the curve practically impossible in the case of a very low perfusion. Moreover, a change of the curve amplitude in the plethysmogram is also dependent on the oxygen saturation and not only on the amount of blood flowing into the part of the body, for example, a finger.

US 4,867,165 A1 discloses a method for determining the perfusion whereby the perfusion can be quantified. To this end, a so-called perfusion index is determined from measuring values of the pulsoximetry process by means of an algorithm. It has been found to be a drawback of this method, however, that it yields absolute values only so that the detection of a variation of the perfusion by the clinical staff must take place by continuous observation and comparison of numerical values.

It is an object of the invention to mitigate this problem by way of a method for the presentation of information concerning variations of the perfusion, thus facilitating the reading out of this information while avoiding said drawbacks.

In respect of the method this object is achieved as disclosed in the characterizing part of claim 1 whereas in respect of the device it is achieved as disclosed in claim 21.

Further features of the invention are disclosed in the claims 16 to 18 and in the dependent claims.

The invention is based on the recognition of the fact that information represented by autonomous graphic elements can be observed faster and simpler than information that has to be derived by interpretation of curves or comparison of several numerical values.

In accordance with the invention, the numerical data (perfusion index) required for the graphic presentation of the variations of the perfusion is determined continuously from measuring values of the photometric measuring process while using an algorithm. A first perfusion index is defined as a reference value and the relative deviations of the subsequent perfusion indices are determined in relation to this reference value. These

relative deviations are represented by analog graphic elements on the user surface of the display screen as information concerning the variation of the perfusion.

Thus, it is simply possible to read out the relative variation of the perfusion, which is presented in the form of analog graphic elements. Such a representation is very advantageous, because the clinical staff is presented with significant and ready-for-use information concerning the variation of the perfusion. Interpretation on the basis of the plethysmography curve or by continuous observation and comparison of numerical values is no longer necessary. Moreover, the size of presentation of the plethysmography curve can now be automatically adapted to the signal, thus facilitating interpretation of the curve characteristic.

Preferably, the reference value is automatically determined at the beginning of the photometric measuring process.

The instant for determining the reference value, however, can also be chosen at will by the clinical staff. It is thus ensured that a negative effect on the reference value, for example, due to a temporary state of shock of the patient or the like, can be precluded by way of a suitable choice of the instant for determining the reference value.

For reasons of flexibility, for example, for the comparison of two reference values of a patient which have been determined at different instants, such values can be stored on a memory chip.

In order to enable adjustment of the size of the graphic element and hence of the presentation of the information concerning variations of the perfusion, the reference value as well as the subsequent perfusion indices can be normalized or scaled with a factor.

Preferably, this factor is individually adjustable. The individual adjustability offers the advantage that the representation can be readjusted in dependence on a relevant situation, for example, also during an operation, so that an optimum presentation of the information concerning variations of the perfusion is always ensured.

In order to ensure a clear, readily recognizable presentation of the information, the information concerning variations of the perfusion is presented in the form of bar elements.

The relative variations of the perfusion are preferably represented by way of different lengths of the bars. The use of different bar lengths for the representation of the relative variation has been found to be advantageous, because it ensures in a simple manner a fast optical and intuitive recognition of a change of information by the clinical staff.

In order to facilitate the recognition of critical variations of the perfusion there is provided an upper alarm limit and a lower alarm limit, each of which is individually adjustable. When a critical value is reached, that is, when the adjusted alarm limits are exceeded, such an event can then be accentuated by means of an optical and/or acoustic
5 signal.

Preferably, the quality of the measuring values (signal quality) acquired during the photometric measuring process is presented on the user surface of the display screen by way of a different color of icons or background areas, that is, the color green for everything in order, yellow for dubious and red for poor. The estimation of the signal quality can be
10 performed, for example, by evaluation of a combination of various parameters such as, for example, transmission level, interference level, artifact level, signal waveform, perfusion index or the like. The additional presentation of the signal quality is of major importance to the clinical staff, because it enables an evaluation of the measuring values derived from pulsoximetry as well as an evaluation of the information concerning the variations of the
15 perfusion. Moreover, the coloring ensures intuitive observation, which in turn substantially simplifies the interpretation of the indicated signal quality.

Preferably, the same graphic elements are used for the presentation of the variations of the perfusion and for the presentation of the signal quality. Thus, a bar element provided for the presentation of the variation of the perfusion may at the same time be
20 colored, that is, green for the signal quality o.k., yellow for a reduced signal quality, or red for a poor signal quality. This form of presentation, where the icons for the presentation of the signal quality are identical to the graphic elements for the presentation of the variations of the perfusion, has been found to be advantageous, because it results in a space-saving display format. A further space-saving possibility for presentation consists in that a background area,
25 for example, the background of the bar elements, the plethysmography curve or also the background of the numerical display for the oxygen saturation, is characterized by a corresponding color. Coloring of other elements, for example, of the plethysmography curve itself, is also feasible.

However, it is also possible to present the icons as independent graphic
30 elements, notably as a segment or bar representation, as color-encoded surface elements, or in the form of three circular elements arranged like a traffic light.

The device for carrying out the method includes a pulsoximeter for determining the arterial O₂ saturation and for calculating the perfusion index for the determination of the information concerning the variation of the perfusion, means for

detecting interference signals, notably motion artifacts, and for estimating the quality of the acquired measuring values and hence the information concerning a variation of the perfusion, and means for displaying the information.

Further advantages and feasible applications of the present invention are disclosed in the following description in conjunction with the embodiment which is shown in the drawing.

The invention is described more or less diagrammatically hereinafter on the basis of an embodiment as shown in the drawing. Therein:

Fig. 1 is a diagrammatic representation of a user surface of a display screen as used in the field of patient monitoring,

Fig. 2 shows a measuring cap which is fitted on the tip of a finger and comprises two light-emitting diodes and a photoreceiver,

Fig. 3 shows a part of a further user surface with graphic elements for the presentation of the perfusion,

Fig. 4 shows a part of a user surface with graphic elements for the presentation of the perfusion and independent graphic elements for the presentation of the signal quality, and

Fig. 5 shows a further part of a user surface with graphic elements for the presentation of the variation of the perfusion.

For a better understanding of the invention a brief description will first be given of the procedures used thus far for the determination of the perfusion of a patient.

Fig. 1 shows a typical user surface 10 as used in the field of patient monitoring. The Figure shows inter alia a plurality of dynamically varying patient data, such as an ECG (electrocardiography) curve (derivative I) 12, a further ECG curve (derivative II) 14, a plethysmography curve 16 as well as a CO₂ respiration curve 18. To the right of the real-time curves 12, 14, 16 and 18 the associated physiological values are displayed in numerical form. For example, to the right of the plethysmography curve 16 the current value of the oxygen saturation of the arterial blood (SPO₂ value) 20 is shown with associated alarm limits 22.

With regard to the perfusion to be monitored, thus far the plethysmography curve 16 was observed by the clinical staff in order to derive information as regards the current perfusion by interpretation of the varying curve amplitude.

As is known, the plethysmography curve 16 is determined by means of a photometric measuring process, that is, the so-called pulseoximetry.

Pulseoximetry is a spectrophotometric method for the non-invasive determination of the arterial oxygen saturation of the blood. To this end, use is made of a measuring cap 24 as shown in Fig. 2, which cap comprises two light-emitting diodes 26, 28 and a photoreceiver 30 and is fitted on the tip 32 of a finger of the patient to be monitored. The arteries 36 and veins 38 extending in the tissue 34 and the capillaries 40 present between the arteries 36 and veins 38 are denoted by dashed lines. The light-emitting diodes 26 and 28 emit light of different wavelength, for example, 660 nm and 950 nm, to the photoreceiver 30. The photoreceiver 30 measures the intensity variation of the light which is due to a variation of an arterial blood volume and converts this information into a current signal which serves inter alia to present the plethysmography curve 16 on the user surface 10. Since photometric measuring methods are well known, for the sake of simplicity the measuring method will not be shown or elaborated further.

In order to enable direct representation of the variations of the perfusion of a patient, a known algorithm is used to determine the so-called perfusion index from the measuring values continuously produced by pulseoximetry. After a first perfusion index has been defined as a reference value, the relative deviations of the subsequently calculated perfusion indices are determined relative to the reference value. Such relative deviations then serve as information concerning the variation of the perfusion and are presented on the user surface 10 in the form of graphic elements.

Because artifacts due to optical disturbances or motion of the patient are recognized prior to the calculation of the perfusion index and filtered by the algorithm, it is ensured that the information displayed in respect of the variation of the perfusion is highly accurate.

For reasons of simplicity, the algorithms necessary for the calculation of the perfusion indices and the presentation of the graphic elements on the user surface 10 will not be elaborated further herein.

Fig. 3 shows a part of a further user surface 10 as used in the field of patient monitoring. In addition to the plethysmography curve 16 and the current SPO_2 value 20 with associated alarm limits 22, information concerning the variation of the perfusion is also

shown. The information is represented by means of two bar elements 42, 44. The numerical value of the perfusion 46 is displayed to the right of the bar elements 42, 44. Moreover, a symbol 48 indicates that corresponding alarm limits for the perfusion have been deactivated.

Whereas the bar element 42 symbolizes the reference value so that the length of the bar element 42 is constant, the bar element 44 represents, by way of its variable length, the variation of the perfusion in relation to the reference value. The fact that the length of the bar element 44 is variable is denoted by the dashed line 50.

The variation of the perfusion can then be readily and intuitively read out by the clinical staff via the different bar length. In order to ensure optimum presentation, the bar elements 42, 44 can be scaled, that is, the length of the bar element 42 can be individually adjusted, causing a corresponding variation of the length of the bar element 44.

The additional display of the estimate of the signal quality as derived by evaluation of various parameters such as the transmission level, interference level, artifact level, signal waveform and perfusion index, is realized by way of corresponding coloring of the bar elements 42, 44 shown. For example, a green bar element indicates a good signal quality while a yellow element indicates a dubious signal quality and a red bar element indicates a poor signal quality.

Fig. 4 shows a further possibility for the representation of the signal quality. Fig. 4 again concerns a part of a user surface 10 as used in the field of patient monitoring. The user surface 10 again displays the plethysmography curve 16, the SPO₂ value 20 with alarm limits 22 and the bar elements 42, 44 for presenting the variation of the perfusion with the associated numerical value 46. Three circular elements 52 are arranged horizontally adjacent one another as graphic elements for the presentation of the signal quality, that is, underneath the numerical value 46 of the perfusion. The signal quality is indicated in known manner by way of corresponding coloring of the circular elements, that is, green = good signal quality, yellow = mediocre signal quality, and red = poor signal quality.

Fig. 5 shows a further version in which only the variation of the perfusion is represented via the element 44, 50 in addition to the numerical information 20, 22 and 46 so that more room is available for the display of the plethysmography curve 16. The reference value is indicated by way of a further graphic element 54, for example, the tip of an arrow or a line.

LIST OF REFERENCES:

	10	user surface for patient monitoring
	12	ECG curve, derivative I
	14	ECG curve, derivative II
	16	plethysmography curve
5	18	CO ₂ respiration curve
	20	SPO ₂ value
	22	alarm limits
	24	measuring cap
	26	first light-emitting diode
10	28	second light-emitting diode
	30	photoreceiver
	32	finger cap
	34	tissue
	36	arteries
15	38	veins
	40	capillaries
	42	first bar element
	44	second bar element
	46	numerical value of the perfusion
20	48	symbol for deactivated alarm limits
	50	variation of the length of the second bar element
	52	independent graphic elements for indicating the signal quality
	54	marking of the reference value

CLAIMS:

1. A method for the presentation of information concerning variations of the arterial filling with blood (perfusion) of organs of living beings on the user surface (10) of a display unit, in which method the data required for the presentation (perfusion index) is determined, using an algorithm, from measuring values produced by a non-invasive
5 photometric measuring process for determining the arterial oxygen saturation of the blood, characterized in that a first perfusion index is defined as a reference value and the subsequent perfusion indices are determined as relative deviations with respect to the reference value, said relative deviations being presented as information concerning the variations of the perfusion on the user surface (10).
10
2. A method as claimed in claim 1, characterized in that the determination of the reference value takes place automatically at the beginning of the photometric measuring process.
- 15 3. A method as claimed in claim 1, characterized in that the instant of determination of the reference value can be chosen at will.
4. A method as claimed in the claims 1 to 3, characterized in that the reference value is stored on a memory chip.
20
5. A method as claimed in one of the preceding claims, characterized in that the reference value as well as the subsequent perfusion indices are scaled by a factor.
6. A method as claimed in claim 5, characterized in that the factor is adjustable.
25
7. A method as claimed in one of the preceding claims, characterized in that the variation of the perfusion is presented in numerical form.

8. A method as claimed in one of the preceding claims, characterized in that analog graphic elements (42, 44) are used for the presentation.
9. A method as claimed in claim 8, characterized in that bar elements (42, 44) are used as the graphic elements.
10. A method as claimed in claim 9, characterized in that the relative variations of the perfusion are represented by different bar lengths.
11. A method as claimed in claim 8, characterized in that a representation in conformity with a tachometer display is used as the graphic element.
12. A method as claimed in claim 8, characterized in that the display is formed as a multidimensional type in conjunction with other physiological variables, notably as a spider diagram.
13. A method as claimed in one of the preceding claims, characterized in that an upper alarm limit and a lower alarm limit are provided.
14. A method as claimed in claim 13, characterized in that the alarm limit is adjustable.
15. A method as claimed in the claims 13 and 14, characterized in that an acoustic and/or optical alarm signal is triggered when the alarm limit is exceeded.
16. A method of determining the quality of the measuring values (signal quality) derived by means of a photometric measuring process, notably in combination with a method as claimed in one of the preceding claims, characterized in that the signal quality is determined by a single one or a combination of the following variables:
- saturation-independent perfusion index
 - transmission factor
 - extent of ambient disturbances, such as stray light, EM radiation and the like
 - shape of the PLETH signal
 - strength and/or duration of artifacts.

17. A method of determining the quality of the measuring values (signal quality) derived by means of a photometric measuring process, characterized in that the signal quality is determined by the modulation factor (AC/DC) of one or more wavelengths in combination
5 with one or more of the following variables:

- saturation-independent perfusion index
- transmission factor
- extent of ambient disturbances, such as stray light, EM radiation, and the like
- shape of the PLETH signal
- 10 - strength and/or duration of artifacts.

18. A method of presenting the quality of the measuring values (signal quality) derived by means of the photometric measuring process, notably as claimed in claim 16 or 17, characterized in that this information is graphically presented on the user surface (10) by
15 way of different coloring of icons and/or background areas, notably in green for everything o.k., yellow for dubious quality and red for a poor quality.

19. A method as claimed in claim 18, characterized in that the icons are identical to the graphic elements (42, 44) used for the presentation of the perfusion.
20

20. A method as claimed in claim 18 or 19, characterized in that the icons are independent graphic elements (52), notably segment-like or bar-like presentations, color-encoded surface elements or circular elements arranged in the form of a traffic light.

25 21. A device for carrying out the method, comprising a pulseoximeter for determining the arterial O₂ saturation and for calculating the perfusion index in order to determine the information concerning the variation of the perfusion, means for the detection of interference signals, notably motion artifacts, and for estimating the quality of the measuring values acquired and hence the information concerning a
30 variation of the perfusion, and means for presenting the information.



10

FIG.1

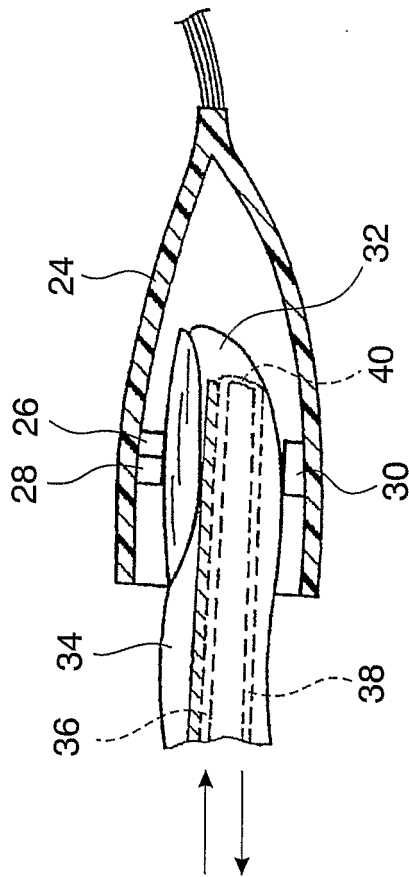

FIG.2

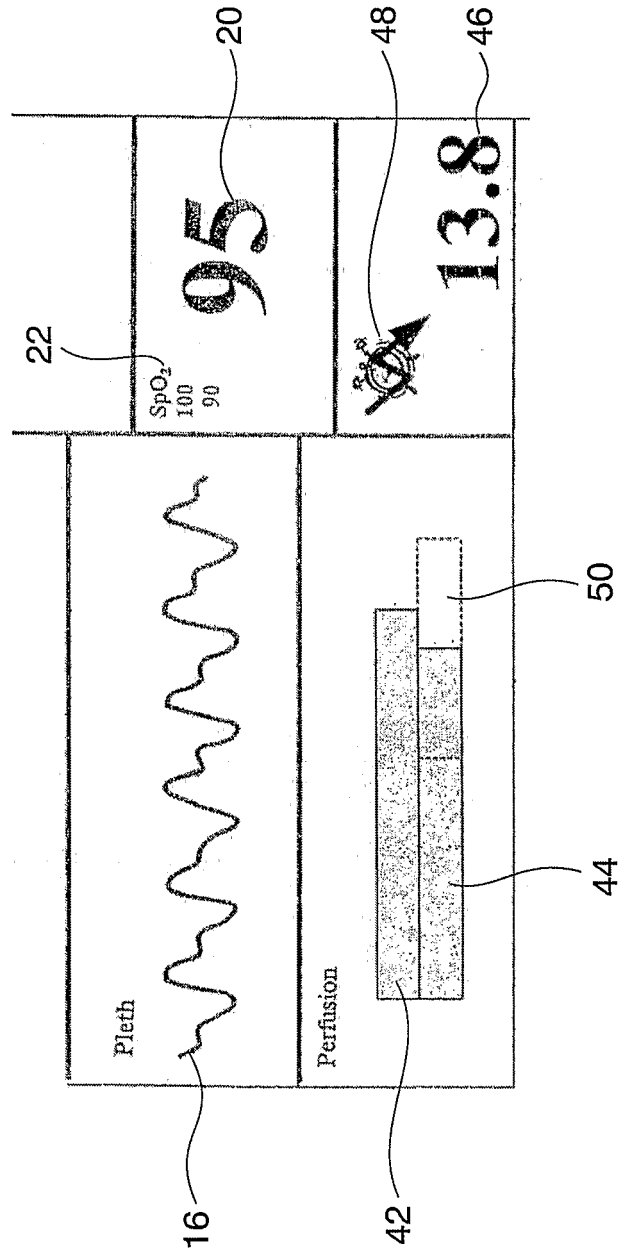

FIG.3

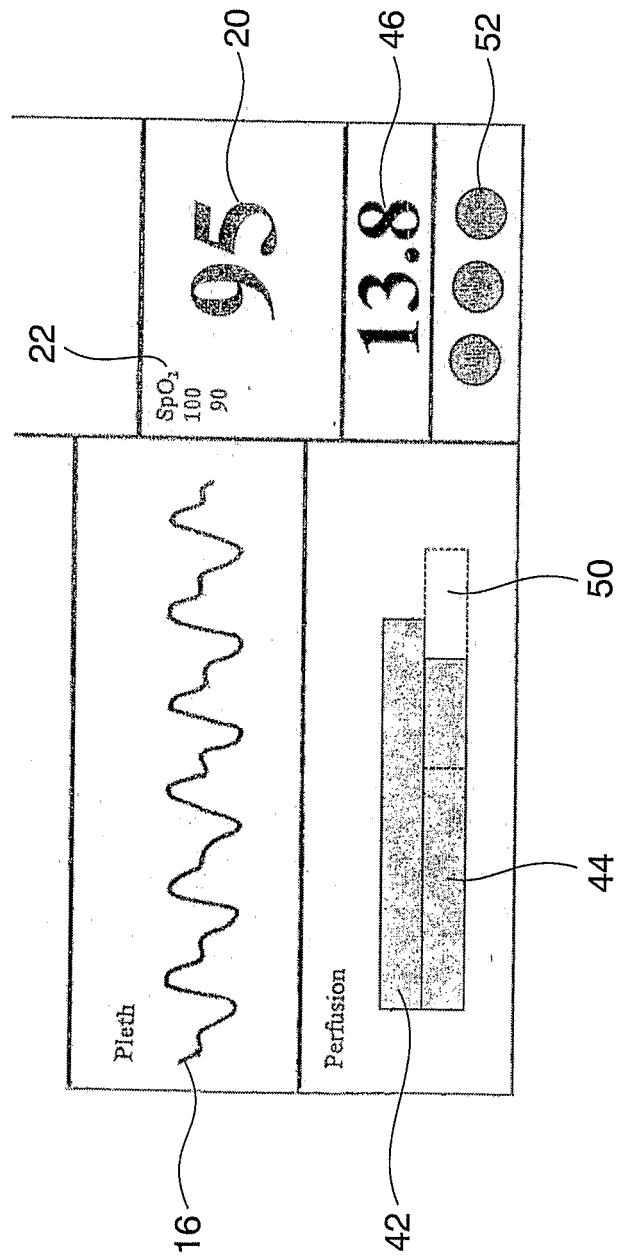

FIG.4

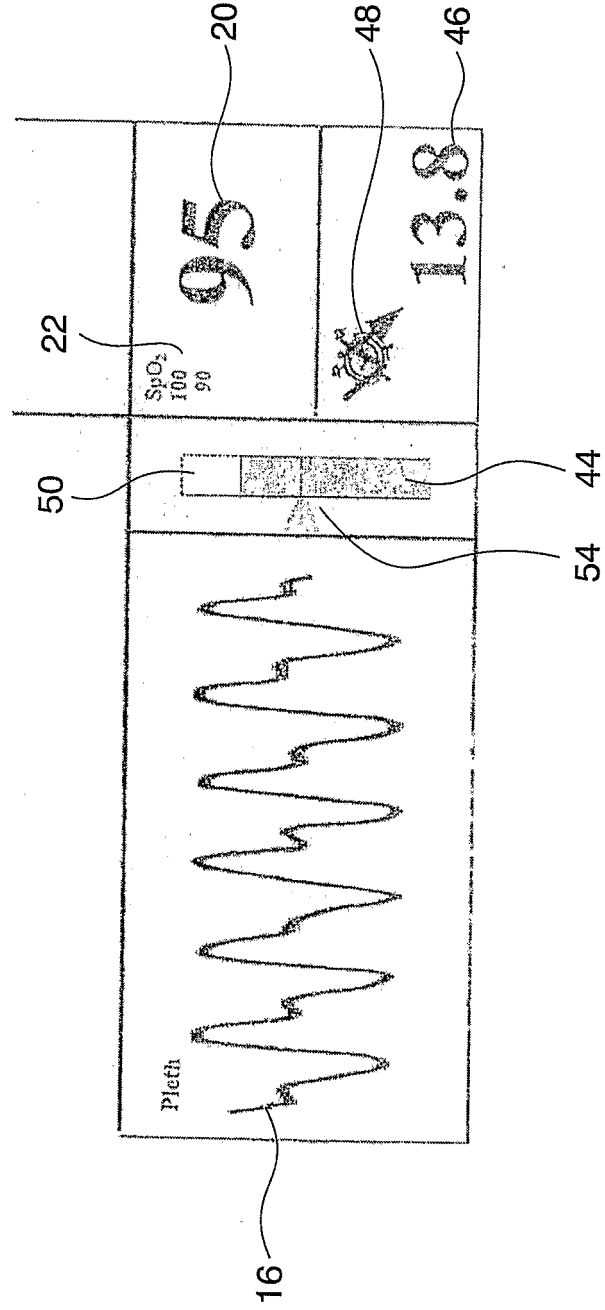

FIG.5

专利名称(译)	用于呈现关于灌注变化的信息的方法		
公开(公告)号	EP1553870A2	公开(公告)日	2005-07-20
申请号	EP2003808819	申请日	2003-10-02
[标]申请(专利权)人(译)	皇家飞利浦电子股份有限公司		
申请(专利权)人(译)	飞利浦知识产权及标准部GMBH 皇家飞利浦电子N.V.		
当前申请(专利权)人(译)	飞利浦知识产权及标准部GMBH 皇家飞利浦电子N.V.		
发明人	NEUMANN, ROLF,PHILIPS INTEL. PROP. & STAND. GMBH BINDSZUS, ANDREAS,PHILIPS I. P. & STAND. GMBH		
IPC分类号	A61B5/00 A61B5/026		
CPC分类号	A61B5/6826 A61B5/0261 A61B5/14551 A61B5/14552 A61B5/6838 A61B5/742		
优先权	10247984 2002-10-15 DE		
外部链接	Espacenet		

摘要(译)

一种用于在显示屏的用户表面 (10) 上呈现关于生物器官的血液 (灌注) 的动脉填充的变化的信息的方法, 在该方法中, 导出所需的数据 (灌注指数)。使用算法, 从测量非侵入性光度测量过程的值来确定血液的动脉血氧饱和度。本发明的特征在于, 第一灌注指数被定义为参考值, 随后的灌注数据被确定为相对于参考值的相对偏差, 所述相对偏差以模拟, 图形元素的形式呈现 (42,44)。) 在用户表面 (10) 上作为关于灌注的10种变化的信息。