

(19)



(11)

EP 2 366 327 B1

(12)

EUROPEAN PATENT SPECIFICATION

(45) Date of publication and mention of the grant of the patent:
17.04.2019 Bulletin 2019/16

(51) Int Cl.:
A61B 1/07 (2006.01) **A61B 1/05 (2006.01)**
A61B 1/04 (2006.01) **A61B 5/1455 (2006.01)**
G06T 5/00 (2006.01) **A61B 5/00 (2006.01)**

(21) Application number: **11152565.5**

(22) Date of filing: **28.01.2011**

(54) An electronic endoscope system and a method of acquiring blood vessel information

Elektronisches Endoskopsystem und Verfahren zur Erfassung von Blutgefäßinformationen

Système d'endoscope électronique et procédé d'acquisition d'informations relatives aux vaisseaux sanguins

(84) Designated Contracting States:
**AL AT BE BG CH CY CZ DE DK EE ES FI FR GB
 GR HR HU IE IS IT LI LT LU LV MC MK MT NL NO
 PL PT RO RS SE SI SK SM TR**

(30) Priority: **19.03.2010 JP 2010064049**

(43) Date of publication of application:
21.09.2011 Bulletin 2011/38

(73) Proprietor: **Fujifilm Corporation**
Minato-ku
Tokyo (JP)

(72) Inventor: **Saito, Takaaki**
Kanagawa (JP)

(74) Representative: **Klunker IP**
Patentanwälte PartG mbB
Destouchesstraße 68
80796 München (DE)

(56) References cited:
EP-A1- 2 305 094 **JP-A- 1 280 442**
JP-A- 2001 037 718 **JP-A- 2003 204 925**
US-A1- 2004 064 016 **US-A1- 2007 135 715**
US-A1- 2009 147 096 **US-A1- 2009 247 881**
US-A1- 2010 054 576

EP 2 366 327 B1

Note: Within nine months of the publication of the mention of the grant of the European patent in the European Patent Bulletin, any person may give notice to the European Patent Office of opposition to that patent, in accordance with the Implementing Regulations. Notice of opposition shall not be deemed to have been filed until the opposition fee has been paid. (Art. 99(1) European Patent Convention).

Description

BACKGROUND OF THE INVENTION

[0001] The present invention relates to an electronic endoscope system, an electronic endoscope processor, and a method of acquiring blood vessel information for acquiring information on a blood vessel from an image acquired by an electronic endoscope and producing an image from the acquired information.

[0002] In recent years, the field of medicine has been seeing a number of diagnoses and treatments using electronic endoscopes. A typical electronic endoscope is equipped with an elongated insertion section that is inserted into a subject's body cavity. The insertion section has therein incorporated an imager such as a CCD at the tip thereof. The electronic endoscope is connected to a light source device, which emits light that, leaving the tip of the insertion section, illuminates the inside of a body cavity. With the inside of the body cavity illuminated by light, the subject tissue inside the body cavity is imaged by an imager provided at the tip of the insertion section. Images acquired by imaging undergo various kinds of processing by a processor connected to the electronic endoscope before being displayed by a monitor. Thus, the electronic endoscope permits real-time observation of the images showing the inside of the subject's body cavity and thus enables sure diagnoses.

[0003] The light source device uses a white light source such as a xenon lamp capable of emitting white broadband light whose wavelength ranges from a blue region to a red region. Use of white broadband light to illuminate the inside of a body cavity permits observing the whole subject tissue from acquired images thereof. However, although images acquired by broadband light illumination permit generally observing the whole subject tissue, there are cases where such images fail to enable clear observation of subject tissues such as extremely small blood vessels, deep-layer blood vessels, pit patterns, and uneven surface profiles formed of recesses and bumps. As is known, such subject tissues may be made clearly observable when illuminated by narrowband light having a wavelength limited to a specific range. As is also known, image data obtained by illumination with narrowband light yields various kinds of information on a subject tissue such as oxygen saturation level in a blood vessel.

[0004] For example, JP 2001-37718 A describes a device wherein a blood information amount calculator calculates a blood information amount in a subject and a region setting unit sets a given region of an endoscopic image whereupon a simulated image data generator uses the information on the specified region and the calculated blood information amount to produce simulated image data that permits recognition of its quantitative change, and an image synthesizer combines the produced simulated image data with the endoscopic image to produce and output synthesized data.

[0005] JP 2648494 B describes illuminating with near-

infrared narrow-band light IR1 and IR3 whose vascular absorbances change according to oxygen saturation level and a near-infrared narrow-band light IR2 whose vascular absorbance does not change in order to acquire an image each time different light is emitted. Then, images acquired by illuminating with narrowband light IR1 and IR3 whose vascular absorbances change and an image acquired by illuminating with narrowband light IR2 whose vascular absorbance does not change are used to calculate variations in luminance between the images, whereupon the calculated variations in luminance are incorporated in the images in monochrome or simulated color. The image thus produced provides information on an oxygen saturation level in a blood vessel.

[0006] US 2009/147096 relates to a position specifying system including a light irradiation section, an image capturing section and a position specifying section, wherein the position specifying section specifies a depth of the object from a surface of the physical body.

[0007] US 2007/0135715 relates to an endoscopic diagnosis support method including steps of calculating and discerning, wherein the step of discerning discerns an image zone including a bleeding region by judging a difference among the plural image zones based on a calculated tone of each image zone.

[0008] US 2004/0064016 relates to a diagnosis supporting system comprising an image signal acquiring section and an observation image signal generating section, wherein the observation image signal generating section calculates a difference between brightness level of a pixel in a reference image signal and brightness level of a pixel in a fluorescent image signal at the corresponding position for all of the pixels in the reference image signal.

SUMMARY OF INVENTIION

[0009] However, the devices described in JP 2001-37718 A and JP 2648494 B are incapable of calculating a relative value with respect to a reference given by a blood information amount corresponding to a specific region (blood vessel information), and this in some cases presented a problem related to robustness of blood information amount such as, for example, oxygen saturation level.

[0010] An object of the present invention is to provide a distribution image with an improved robustness of blood vessel information.

[0011] In order to attain the above objects, the invention provides an electronic endoscope system comprising the features of claims 1.

[0012] Preferred embodiments are defined by the dependent claims.

[0013] In order to attain the above objects, the invention provides a processor of the above electronic endoscope system.

[0014] In order to attain the above objects, the invention provides a method of acquiring blood vessel information comprising the steps of claim 8.

[0015] The present invention enables acquisition of a distribution image having an improved robustness of blood vessel information by calculating blood vessel information as a relative value for the whole region with respect to a reference given by a value of blood vessel information for a reference value region.

BRIEF DESCRIPTION OF DRAWINGS

[0016]

Fig. 1 is an external view of an electronic endoscope system according to a first embodiment of the invention.

Fig. 2 is a block diagram illustrating an electric configuration of the electronic endoscope system according to the first and a second embodiments of the invention.

Fig. 3 is a graph illustrating spectral transmittances of red, green, and blue filters.

Fig. 4A is a view for explaining operations of a CCD in a normal light image mode; Fig. 4B is a view for explaining operations of a CCD in a special light image mode.

Fig. 5 is a graph illustrating an absorption coefficient of hemoglobin.

Fig. 6 is a graph illustrating a correlation between first and second luminance ratios $S1/S3$ and $S2/S3$ on the one hand and blood vessel depth and oxygen saturation level on the other hand.

Fig. 7A is a view for explaining how a coordinate point (X^* , Y^*) in a luminance coordinate system is obtained from first and second luminance ratios $S1^*/S3^*$ and $S2^*/S3^*$; Fig. 7B is a view for explaining how a coordinate point (U^* , V^*) in a blood vessel information coordinate system corresponding to the coordinate point (X^* , Y^*) is obtained.

Fig. 8 shows image views illustrating an example of a screen given by a monitor for displaying either an absolute value oxygen saturation level image or a relative value oxygen saturation level image.

Fig. 9 shows image views illustrating an example of a screen given by a monitor for simultaneously displaying both an absolute value oxygen saturation level image and a relative value oxygen saturation level image.

Fig. 10 is an image view illustrating an example of a screen of a monitor where blood vessel information, i.e., blood vessel depth information and absolute value oxygen saturation level information, are given in textual information together with an image.

Fig. 11 is a flow chart illustrating a procedure of calculating absolute value, reference value, and relative value oxygen saturation level information and a procedure of producing absolute value and relative value oxygen saturation level images incorporating such information.

Fig. 12 is a flow chart following the flow of Fig. 11.

Fig. 13 is a block diagram illustrating an electric configuration of the electronic endoscope system according to a third embodiment of the invention.

Fig. 14 is a schematic view of a rotary filter.

Fig. 15 is a block diagram illustrating an electric configuration of the electronic endoscope system according to a fourth embodiment not according to the invention.

10 DETAILED DESCRIPTION OF INVENTION

[0017] The electronic endoscope system of the invention will be described in detail below based on preferred embodiments illustrated in the attached drawings.

15 **[0018]** Fig. 1 is an external view of a configuration of the electronic endoscope system according to a first embodiment of the invention.

[0019] As illustrated in Fig. 1, an electronic endoscope system 10 according to the first embodiment of the invention comprises an electronic endoscope 11 for imaging the inside of a subject's body cavity, a processor 12 for producing an image of a subject tissue in the body cavity based on a signal acquired by imaging, a light source device 13 for supplying light for illuminating the inside of the body cavity, and a monitor 14 for displaying the image of the inside of the body cavity.

20 **[0020]** The electronic endoscope 11 comprises a flexible insertion section 16 that is inserted into a body cavity, an operating section 17 provided at the base of the insertion section 16, and a universal cord 18 for connecting the operating section 17 to the processor 12 and the light source device 13.

25 **[0021]** The insertion section 16 has a bending portion 19 at the tip thereof comprising connected bending pieces. The bending portion 19 bends up and down, left and right in response to the operation of an angle knob 21 of the operating section 17. The bending portion 19 has at its tip an end portion 16a incorporating an optical system and other components for imaging the inside of a body cavity. The end portion 16a can be directed in a desired direction in the body cavity according to a bending operation of the bending portion 19.

30 **[0022]** The universal cord 18 has a connector 24 provided on the side thereof leading to the processor 12 and the light source device 13. The connector 24 is a composite type connector composed of a communication connector and a light source connector and removably connects the electronic endoscope 11 to the processor 12 and the light source device 13.

35 **[0023]** As illustrated in Fig. 2, the light source device 13 comprises a broadband light source 30, a shutter 31, a shutter actuator 32, first to third narrowband light sources 33 to 35, a coupler 36, and a light source selector 37.

40 **[0024]** The broadband light source 30 is a xenon lamp, a white LED, a micro-white (trademark) light source, or the like and produces broadband light BB having a wavelength ranging from a blue region to a red region (about 470 nm to 700 nm). The broadband light source 30 re-

mains lighted at all times when the electronic endoscope 11 is in operation. The broadband light BB emitted from the broadband light source 30 is focused by a condenser lens 39 before entering a broadband optical fiber 40.

[0025] The shutter 31 is disposed between the broadband light source 30 and the condenser lens 39 so as to be movable between its inserted position where the shutter 31 is located on the optical path of the broadband light BB to block the broadband light BB and its retracted position where the shutter 31 is retracted from the inserted position to allow the broadband light BB to travel toward the condenser lens 39.

[0026] The shutter actuator 32 is connected to a controller 59 in the processor 12 to control the actuation of the shutter 31 according to an instruction from the controller 59.

[0027] The first to the third narrowband light sources 33 to 35 are laser diodes or the like. The first narrowband light source 33 produces narrowband light having a wavelength limited to 440 nm +/- 10 nm, preferably 445 nm (referred to below as "first narrowband light N1"), the second narrowband light source 34 produces narrowband light having a wavelength limited to 470 nm +/- 10 nm, preferably 473 nm (referred to below as "second narrowband light N2"), and the third narrowband light source 35 produces narrowband light having a wavelength limited to 400 nm +/- 10 nm, preferably 405 nm (referred to below as "third narrowband light N3"). The first to the third narrowband light sources 33 to 35 are connected respectively to first to third narrowband optical fibers 33a to 35a, allowing the first to the third narrowband light N1 to N3 to enter the first to the third narrowband optical fibers 33a to 35a.

[0028] The coupler 36 connects a light guide 43 in the electronic endoscope to the broadband optical fiber 40 and the first to the third narrowband optical fibers 33a to 35a. Thus, the broadband light BB can enter the light guide 43 through the broadband optical fiber 40. The first to the third narrowband light N1 to N3 can enter the light guide 43 through the first to the third narrowband optical fibers 33a to 35a.

[0029] The light source selector 37 is connected to the controller 59 in the processor and turns on or off the first to the third narrowband light sources 33 to 35 according to an instruction by the controller 59. In the normal light image mode using the broadband light BB, the inside of a body cavity is illuminated by the broadband light BB to acquire a normal light image while the first to the third narrowband light sources 33 to 35 are turned off. In the special light image mode using the first to the third narrowband light N1 to N3, the illumination of the inside of the body cavity by the broadband light BB is terminated while the first to the third narrowband light sources 33 to 35 are sequentially turned on to acquire special light images.

[0030] Specifically, the light source selector 37 first turns on the first narrowband light source 33. Then, imaging of the subject tissue is started with the first narrow-

band light N1 illuminating the inside of the body cavity. Upon completion of imaging, the controller 59 gives a light source switching instruction to turn off the first narrowband light source 33 and turn on the second narrowband light source 34. Likewise, upon completion of imaging with the second narrowband light N2 illuminating the inside of the body cavity, the second narrowband light source 34 is turned off and the third narrowband light source 35 is turned on. Upon completion of imaging with the third narrowband light N3 illuminating the inside of the body cavity, the third narrowband light source 35 is turned off.

[0031] The electronic endoscope 11 comprises the light guide 43, a CCD 44, an analog processor circuit 45 (AFE: analog front end), and an imaging controller 46.

[0032] The light guide 43 is a large-diameter optical fiber, a bundle fiber, or the like having its light-receiving end inserted in the coupler 36 in the light source device, whereas its light emitting end is directed toward an illumination lens 48 located in the leading end portion 16a. The light emitted from the light source device 13 is guided through the light guide 43 and then emitted toward the illumination lens 48. The light admitted in the illumination lens 48 is emitted through an illumination window 49 attached to the end face of the leading end portion 16a to illuminate the inside of the cavity. The broadband light BB and the first to the third narrowband light N1 to N3 reflected by the inside of the body cavity pass through an observation window 50 attached to the end face of the leading end portion 16a to enter a condenser lens 51.

[0033] The CCD 44 receives the light from the condenser lens 51 with its imaging surface 44a, performs photoelectric conversion of the received light to accumulate a signal charge, and reads out the accumulated signal charge as an imaging signal. The read-out imaging signal is transmitted to an AFE 45. The CCD 44 is a color CCD whose imaging surface 44a has arranged therein three colors of pixels, red (R) pixels, green (G) pixels, and blue (B) pixels, each provided with one of a red filter, a green filter, and a blue filter.

[0034] As illustrated in Fig. 3, the red filters, the green filters, and the blue filters have spectral transmittances 52, 53, and 54, respectively. Among the light entering the condenser lens 51, the broadband light BB has a wavelength ranging from about 470 nm to 700 nm. The red filters, the green filters, and the blue filters pass a wavelength range of broadband light BB corresponding to their spectral transmittances 52, 53 and 54. Now, let imaging signal R be a signal photoelectrically converted by a red pixel, imaging signal G a signal photoelectrically converted by a green pixel, and imaging signal B a signal photoelectrically converted by a blue pixel. Then, the broadband light BB entering the CCD 44 yields a broadband imaging signal composed of the imaging signal R, the imaging signal G, and the imaging signal B.

[0035] Among the light entering the condenser lens 51, the first narrowband light N1 has a wavelength of 440 nm +/- 10 nm and therefore passes through only the blue

filters. Accordingly, the first narrowband light N1 entering the CCD 44 yields a first narrowband imaging signal composed of an imaging signal B. The second narrowband light N2 has a wavelength of 470 nm +/- 10 nm and therefore passes through both the blue and green filters. Accordingly, the second narrowband light N2 entering the CCD 44 yields a second narrowband imaging signal composed of an imaging signal B and an imaging signal G. The third narrowband light N3 has a wavelength of 400 nm +/- 10 nm and therefore passes through only the blue filters. Accordingly, the first narrowband light N3 entering the CCD 44 yields a third narrowband imaging signal composed of an imaging signal B.

[0036] The AFE 45 comprises a correlated double sampling circuit (CDS), an automatic gain control circuit (AGC), and an analog-to-digital converter (A/D) (none of these are shown). The CDS performs correlated double sampling of an imaging signal supplied from the CCD 44 to remove noise generated by actuation of the CCD 44. The AGC amplifies an imaging signal from which noise has been removed by the CDS. The analog-to-digital converter converts an imaging signal amplified by the AGC into a digital imaging signal having a given number of bits, which is applied to the processor 12.

[0037] The imaging controller 46 is connected to the controller 59 in the processor 12 and sends a drive signal to the CCD 44 in response to an instruction given by the controller 59. The CCD 44 outputs an imaging signal to the AFE 45 at a given frame rate according to the drive signal from the imaging controller 46. In the normal light image mode, a total of two operations are performed in one frame of acquisition period as illustrated in Fig. 4A: a step of accumulating a signal charge through photoelectric conversion of the broadband light BB and a step of reading out the accumulated signal charge as a broadband imaging signal. These operations are repeated throughout the normal light image mode.

[0038] By contrast, when the mode is switched from the normal light image mode to the special light image mode, a total of two operations are first performed in one frame of acquisition period as illustrated in Fig. 4B: a step of accumulating a signal charge through photoelectric conversion of the first narrowband light N1 and a step of reading out the accumulated signal charge as a first narrowband imaging signal. Upon completion of readout of the first narrowband imaging signal, a total of two operations are performed in one frame of acquisition period: a step of accumulating a signal charge through photoelectric conversion of the second narrowband light N2 and a step of reading out the accumulated signal charge as a second narrowband imaging signal. Upon completion of readout of the second narrowband imaging signal, a total of two operations are performed in one frame of acquisition period: a step of accumulating a signal charge through photoelectric conversion of the third narrowband light N3 and a step of reading out the accumulated signal charge as a third narrowband imaging signal.

[0039] As illustrated in Fig. 2, the processor 12 com-

prises a digital signal processor 55 (DSP), a frame memory 56, a blood vessel image producer 57, and a display control circuit 58, all of these components being controlled by the controller 59.

[0040] The DSP 55 performs color separation, color interpolation, white balance adjustment, gamma correction, and the like of the broadband imaging signal and the first to the third narrowband imaging signals outputted from AFE45 in the electronic endoscope to produce broadband image data and the first to the third narrowband image data (first image data). Thus, the DSP 55 is a first image data producing means.

[0041] The frame memory 56 stores the broadband image data and the first to the third narrowband image data produced by the DSP 55. The broadband image data is color image data containing colors of red, green, and blue.

[0042] The blood vessel image producer 57 comprises a luminance ratio calculator 60, a correlation storage 61, a blood vessel depth-oxygen saturation level calculator 62, an oxygen saturation level image producer 64, a relative value image producer 200, and a reference value region setter 210.

[0043] The luminance ratio calculator 60 determines a blood vessel region containing a blood vessel from the first to the third narrowband image data stored in the frame memory 56. The luminance ratio calculator 60 obtains a first luminance ratio S1/S3 between the first and the third narrowband image data and a second luminance ratio S2/S3 between the second and the third narrowband image data corresponding to a pixel at the same position in the blood vessel region. S1 is a luminance of a pixel of the first narrowband image data, S2 a luminance of a pixel of the second narrowband image data, and S3 a luminance of a pixel of the third narrowband image data. The blood vessel region may be determined, for example, by a method whereby the blood vessel region is obtained from the difference between the luminance of a blood vessel region of interest and the luminance of the other region.

[0044] The correlation storage 61 stores a correlation between the first and the second luminance ratios S1/S3 and S2/S3 on the one hand and an oxygen saturation level in a blood vessel and a blood vessel depth on the other hand. That correlation is one where a blood vessel contains hemoglobin exhibiting light absorption coefficients as shown in Fig. 5 and is obtained by analyzing, for example, a number of the first to the third narrowband image data accumulated through diagnoses or the like hitherto made. As illustrated in Fig. 5, the hemoglobins in a blood vessel have light absorption characteristics having the light absorption coefficient μ_a changing according to the wavelength of light used for illumination. The light absorption coefficient μ_a indicates an absorbance, i.e., a degree of light absorption by hemoglobin, and is a coefficient in an expression $I_0 \exp(-\mu_a \times X)$ showing the attenuation of light illuminating the hemoglobin. In this expression, I_0 is the intensity of light emitted from

the light source device to illuminate a subject tissue; x (cm) is a depth of a blood vessel inside the subject tissue.

[0045] A reduced hemoglobin 70 and an oxygenated hemoglobin 71 have different light absorption characteristics such that they have different absorbances except for the isosbestic point at which both exhibit the same absorbance (intersection of light absorption characteristics curves of hemoglobins 70 and 71 in Fig. 5). With a difference in absorbance, the luminance varies even when the same blood vessel is illuminated by light having the same intensity and the same wavelength. The luminance also varies when the illumination light has the same intensity but varies in wavelength because a difference in wavelength causes the light absorption coefficient μ_a to change.

[0046] In view of the light absorption characteristics of hemoglobin as described above and considering the fact that wavelengths whereby the absorbance varies according to the oxygen saturation level lie in a range of 445 nm and 405 nm and that light having a short wavelength and hence having a short reaching depth is required in order to retrieve blood vessel depth information, at least one of the first to the third narrowband light N1 to N3 preferably has a wavelength range whose central wavelength is 450 nm or less. According to the first and the second embodiment of the invention, the first and the third narrowband light are such narrowband light. Further, with the same oxygen saturation level, a difference in wavelength causes a difference in absorption coefficient and also a difference in reaching depth into a mucus membrane. Therefore, using the property of light whose reaching depth varies with the wavelength permits obtaining correlation between luminance ratio and blood vessel depth.

[0047] As illustrated in Fig. 6, the correlation storage 61 stores a correlation in correspondence between the coordinate points in a luminance coordinate system 66 representing the first and the second luminance ratios $S1/S3$ and $S2/S3$ and the coordinate points in a blood vessel information coordinate system 67 representing oxygen saturation level and blood vessel depth. The luminance coordinate system 66 is an XY coordinate system, where the X axis shows the first luminance ratio $S1/S3$ and the Y axis shows the second luminance ratio $S2/S3$. The blood vessel information coordinate system 67 is a UV coordinate system provided on the luminance coordinate system 66, where the U axis shows the blood vessel depth and the V axis shows the oxygen saturation level. Because the blood vessel depth has a positive correlation with the luminance coordinate system 66, the U axis has a positive slope. The U axis shows that a blood vessel of interest is located at an increasingly smaller depth as a position on the U axis moves obliquely up rightward and that a blood vessel of interest is located at an increasingly greater depth as a position on the U axis moves obliquely down leftward. On the other hand, because the oxygen saturation level has a negative correlation with the luminance coordinate system 66, the V

axis has a negative slope. The V axis shows that the oxygen saturation level is lower as a position on the V axis moves obliquely up leftward and that the oxygen saturation level is higher as a position on the V axis moves obliquely down rightward.

[0048] In the blood vessel information coordinate system 67, the U axis and the V axis cross each other at right angles at an intersection P. This is because the magnitude of absorbance reverses between illumination by the first narrowband light N1 and illumination by the second narrowband light N2. More specifically, as illustrated in Fig. 5, illumination by the first narrowband light N1 having a wavelength of 440 nm \pm 10 nm allows the light absorption coefficient of the reduced hemoglobin 70 to be greater than the light absorption coefficient of the oxygenated hemoglobin 71 having a high oxygen saturation level whereas illumination by the second narrowband light N2 having a wavelength of 470 nm \pm 10 nm allows the light absorption coefficient of the oxygenated hemoglobin 71 to be greater than the light absorption coefficient of the reduced hemoglobin 70 having a high oxygen saturation level, thus causing the magnitude of the absorbance to reverse. When narrowband light permitting no absorbance reversal are used in lieu of the first to the third narrowband light N1 to N3, the U axis and the V axis do not cross each other at right angles. With illumination provided by the third narrowband light N3 having a wavelength of 400 nm \pm 10 nm, the oxygenated hemoglobin and the reduced hemoglobin have a substantially equal light absorption coefficient.

[0049] The blood vessel depth-oxygen saturation level calculator 62 determines an oxygen saturation level and a blood vessel depth corresponding to the first and the second luminance ratios $S1/S3$ and $S2/S3$ calculated by the luminance ratio calculator 60 based on the correlation stored in the correlation storage 61. Now, in the first and the second luminance ratios $S1/S3$ and $S2/S3$ calculated by the luminance ratio calculator 60, let $S1^*/S3^*$ and $S2^*/S3^*$ be the first luminance ratio and the second luminance ratio respectively for a given pixel in the blood vessel region.

[0050] As illustrated in Fig. 7A, the blood vessel depth-oxygen saturation level calculator 62 determines a coordinate point (X^*, Y^*) corresponding to the first and the second luminance ratios $S1^*/S3^*$ and $S2^*/S3^*$ in the luminance coordinate system 66. Upon the coordinate point (X^*, Y^*) being determined, the blood vessel depth-oxygen saturation level calculator 62 determines a coordinate point (U^*, V^*) corresponding to the coordinate point (X^*, Y^*) in the blood vessel information coordinate system 67 as illustrated in Fig. 7B. Thus, blood vessel depth information U^* and oxygen saturation level information V^* are obtained for a given pixel in the blood region. The blood vessel depth information U^* and the oxygen saturation level information V^* are reference value blood vessel depth information U_{av}^* and reference value oxygen saturation level information V_{av}^* when reference values are to be obtained; the blood vessel depth infor-

mation U^* and the oxygen saturation level information V^* are absolute blood vessel depth information U_{ab}^* and absolute value oxygen saturation level information V_{ab}^* when absolute values are to be obtained.

[0051] The blood vessel depth-oxygen saturation level calculator 62 obtains the reference value blood vessel depth information U_{av}^* and the reference value oxygen saturation level information V_{av}^* for a reference value region set by a reference value region setter 210 described later and obtains the absolute blood vessel depth information U_{ab}^* and the absolute value oxygen saturation level information V_{ab}^* for the whole imaged blood vessel region. Thus, the luminance ratio calculator 60, the correlation storage 61, and the blood vessel depth-oxygen saturation level calculator 62 are blood vessel information producing means and reference value blood vessel information calculating means.

[0052] The blood vessel depth information is used to determine whether a blood vessel region of interest is a superficial-layer blood vessel region (micro-blood vessel region) or a non-superficial-layer blood vessel region (intermediate-layer blood vessel, deep-layer blood vessel) in a second embodiment.

[0053] The reference value region setter 210 sets a reference value region for obtaining the reference value blood vessel depth information U_{av}^* and the reference value oxygen saturation level information V_{av}^* . The reference value region is a region for calculating a reference value for obtaining relative value blood vessel information (oxygen saturation level information, blood level information). The reference value region may be entered from a console 23 using a pointing device such as a mouse. Alternatively, in order to specify a region other than the superficial-layer blood vessel region (micro-blood vessel) as the reference value region, a region having the absolute blood vessel depth information U_{ab}^* indicating an intermediate-layer blood vessel (diameter of about 20 μm to 100 μm) or a deep-layer blood vessel (diameter of about 100 μm or more) may be automatically specified as the reference value region. Image data of a region set as reference value region will be called second image data.

[0054] The oxygen saturation level image producer 64 has a color map 64a (CM) where color information is assigned according to the level of the oxygen saturation levels. More specifically, the color map 64a permits easy distinction of oxygen saturation level by color assignment such that, for example, a low oxygen saturation level is assigned a color of cyan, a medium oxygen saturation level is assigned a color of magenta, and a high oxygen saturation level is assigned a color of yellow. From the color map 64a, the oxygen saturation level image producer 64 determines color information corresponding to the absolute value oxygen saturation level information V_{ab}^* calculated by the blood vessel depth-oxygen saturation level calculator 62.

[0055] When all the pixels in the blood vessel region have been assigned color information, the oxygen satu-

ration level image producer 64 reads out broadband image data from the frame memory 56 and incorporates color information in the read-out broadband image data. Thus, the absolute value oxygen saturation level image data incorporating absolute value oxygen saturation level information is produced. The absolute value oxygen saturation level image data thus produced is stored again in the frame memory 56. The color information may be incorporated in one of the first to the third narrowband image data or in a synthesized image obtained by combining these in lieu of the broadband image data.

[0056] The relative value image producer 200 has a color map 200a (CM) where color information is assigned according to the level of the oxygen saturation levels. More specifically, the color map 200a permits easy distinction of oxygen saturation level according to the relative value thereof such that, for example, an oxygen saturation level lower than the reference value is assigned a color of blue, an oxygen saturation level equal to the reference value is assigned a color of yellow, and an oxygen saturation level higher than the reference level is assigned a color of red.

[0057] The relative value image producer 200 is a relative value blood vessel information calculating means for obtaining relative value oxygen saturation level information V_r^* , a difference between the absolute value oxygen saturation level information V_{ab}^* and the reference value oxygen saturation level information V_{av}^* calculated by the blood vessel depth-oxygen saturation level calculator 62.

[0058] Similarly to the oxygen saturation level image producer 64, the relative value image producer 200 determines color information corresponding to the relative value oxygen saturation level information V_r^* from the color map 200a. Then, the relative value image producer 200 incorporates this color information in the broadband image data to produce the relative value oxygen saturation level image data. Thus, the relative value image producer 200 is an image producing means.

[0059] Like the absolute value oxygen saturation level image data, the relative value oxygen saturation level image data thus produced is stored in the frame memory 56.

[0060] The display control circuit 58 reads out one or more images from the frame memory 56 and allows the monitor 14 to display the read-out image or images. The images may be displayed in various modes. As illustrated in Fig. 8, for example, the monitor 14 may display a broadband image 72 on one side and an absolute value oxygen saturation level image 73 or the relative value oxygen saturation level image 74 selected by an image selector switch 68 (see Fig. 2) on the other side. In the absolute value oxygen saturation level image 73 illustrated in Fig. 8, a blood vessel image 75 is shown in cyan indicating a lower oxygen saturation level, a blood vessel image 76 is shown in magenta indicating a medium oxygen saturation level, and a blood vessel image 77 is shown in yellow indicating a higher oxygen saturation level. In the

relative value oxygen saturation level image 74, a blood vessel image 80 is shown in cyan indicating an oxygen saturation level lower than a reference value, a blood vessel image 81 is shown in magenta indicating an oxygen saturation level equal to the reference value, and a blood vessel image 82 is shown in yellow indicating an oxygen saturation level higher than the reference value.

[0061] As illustrated in Fig. 9, the absolute value oxygen saturation level image 73 and the relative value oxygen saturation level image 74 may be both displayed simultaneously with the display mode shown in Fig. 8. As illustrated in Fig. 10, in lieu of displaying the absolute value oxygen saturation level image 73 and the relative value oxygen saturation level image 74, a given blood vessel image 85 in the broadband image 72 may be specified, with the oxygen saturation level (StO_2 (saturated oxygen)) of the blood vessel image 85 given in textual information.

[0062] Next, we will describe a procedure of calculating the blood vessel depth-oxygen saturation level information and a procedure of producing the absolute value oxygen saturation level image and the relative value oxygen saturation level image incorporating such information referring to the flowchart illustrated in Figs. 11 and 12.

[0063] First, an operator uses the console 23 to perform a freeze operation for acquiring a still image while the normal light image mode is switched to the special light image mode (step S10). When the mode is switched to the special light image mode, the broadband image data as of the time the special light image mode is selected is stored in the frame memory 56 as image data used to produce the oxygen saturation level image (step S12). The broadband image data used to produce the oxygen saturation level image or the like may be broadband image data obtained before operating the console.

[0064] Upon receiving an illumination stop signal from the controller 59, the shutter actuator 32 moves the shutter 31 from the retracted position to the inserted position, causing the broadband light BB to stop illuminating the inside of the body cavity. When illumination by the broadband light BB is stopped, the controller 59 sends the light source selector 37 an illumination start instruction. Thereupon, the light source selector 37 turns on the first narrowband light source 33 to illuminate the inside of the body cavity with the first narrowband light N1 (step S14). Upon the narrowband light N1 illuminating the inside of the body cavity, the controller 59 sends the imaging controller 46 an imaging instruction. Thus, imaging is done by illumination with the first narrowband light N1, and the first narrowband imaging signal obtained by the imaging is sent through the AFE 45 to the DSP 55. The DSP 55 produces the first narrowband image data based on the first narrowband imaging signal. The first narrowband image data thus produced is stored in the frame memory 56 (step S16).

[0065] When the first narrowband image data has been stored in the frame memory 56, the light source selector 37 switches the light for illuminating the inside of the body

cavity from the first narrowband light N1 to the second narrowband light N2 in response to the light source switching instruction from the controller 59 (step S18). Then, imaging is done similarly to the case using the first narrowband light N1 to produce the second narrowband image data based on the second narrowband imaging signal obtained by the imaging. The second narrowband image data thus produced is stored in the frame memory 56 (step S20).

[0066] When the second narrowband image data has been stored in the frame memory 56, the light source selector 37 switches the light for illuminating the inside of the body cavity from the second narrowband light N2 to the third narrowband light N3 in response to the light source switching instruction from the controller 59 (step S22). Then, imaging is done similarly to the cases using the first and the second narrowband light N1, N2 to produce the third narrowband image data based on the third narrowband imaging signal obtained by the imaging. The third narrowband image data thus produced is stored in the frame memory 56 (step S24). Thus, image data obtained by illumination with the individual wavelengths are acquired by the frame sequential method.

[0067] When the broadband image data and the first to the third narrowband image data have been stored in the frame memory 56, the luminance ratio calculator 60 determines the blood vessel region containing a blood vessel from three image data, i.e., the first narrowband image data, the second narrowband image data, and the third narrowband image data. Then, the luminance ratio calculator 60 calculates the first luminance ratio $S1^*/S3^*$ between the first and the third narrowband image data and the second luminance ratio $S2^*/S3^*$ between the second and the third narrowband image data corresponding to a pixel at the same position in the blood vessel region (step S26).

[0068] Next, the blood vessel depth-oxygen saturation level calculator 62 determines the coordinate point (X^* , Y^*) in the luminance coordinate system corresponding to the first and the second luminance ratios $S1^*/S3^*$ and $S2^*/S3^*$ based on the correlation stored in the correlation storage 61. Further, the coordinate point (U^* , V^*) in the blood vessel information coordinate system corresponding to the coordinate point (X^* , Y^*) is determined to obtain the absolute value blood vessel depth information Uab^* and the absolute value oxygen saturation level information Vab^* for a given pixel in the blood vessel region (step S28).

[0069] When the absolute value oxygen saturation level information Vab^* has been obtained, color information corresponding to the absolute value oxygen saturation level information Vab^* is determined from the CM 64a in the oxygen saturation level image producer 64. The color information thus determined is stored in a RAM (not shown) in the processor 12 (step S30).

[0070] Upon storage of the color information in the RAM, the above procedure is followed to obtain the absolute value blood vessel depth information Uab^* and

the absolute value oxygen saturation level information V_{ab}^* corresponding to all the pixels in the blood vessel region and determine color information corresponding to the absolute value oxygen saturation level information V_{ab}^* (step S32).

[0071] Then, when the color information corresponding to the absolute value oxygen saturation level information for all the pixels in the blood vessel region have been obtained, the oxygen saturation level image producer 64 reads out the broadband image data from the frame memory 56 and incorporates the color information stored in the RAM in the broadband image data to produce the absolute value oxygen saturation level image data, which is a simulated color image. The absolute value oxygen saturation level image data thus produced is stored again in the frame memory 56 (step S34).

[0072] The display control circuit 58 reads out the broadband image data and the absolute value oxygen saturation level image data from the frame memory 56 and displays the absolute value oxygen saturation level image on the monitor 14 based on these read-out image data (step S36).

[0073] The reference value region setter 210 causes the monitor 14 to display, for example, a message, so that the operator may set a reference value region for calculating a reference value of the oxygen saturation level using a pointing device (e.g. a mouse) on the console 23. Next, the operator operates the pointing device to set the reference value region (step S38). The reference value region may for example be a region of non-lesion area. Setting the reference value region may be made possible at any time after the absolute value oxygen saturation level image is displayed without the need to display a message, etc.

[0074] When the reference value region has been set, the relative value image producer 200 calculates a mean value of the absolute value oxygen saturation level information V_{ab} of the image data (second image data) in the reference value region as set by the reference value region setter 210 and produces the reference value oxygen saturation level information V_{av} (step S40). The relative value image producer 200 calculates the difference between the absolute value oxygen saturation level information V_{ab} and the reference value oxygen saturation level information V_{av} for all the pixels in the blood vessel region and produces the relative value oxygen saturation level information V_r for all the pixels in the blood vessel region (step S42).

[0075] Upon production of the relative value oxygen saturation level information V_r , a CM 200a in the relative value image producer 200 determines the color information corresponding to the relative value oxygen saturation level information V_r for all the pixels in the blood vessel region. The color information thus determined is stored in the RAM (not shown) in the processor 12 (step S44).

[0076] Then, the relative value image producer 200 reads out the broadband image data from the frame memory 56 and incorporates the color information stored

in the RAM in the broadband image data to produce the relative value oxygen saturation level image data, which is a simulated color image. The relative value oxygen saturation level image data thus produced is stored again in the frame memory 56 (step S46).

[0077] The display control circuit 58 reads out the broadband image data, the absolute value oxygen saturation level image data, and the relative value oxygen saturation level image from the frame memory 56 and displays the broadband image 72, the absolute value oxygen saturation level image 73, and the relative value oxygen saturation level image 74 as illustrated in Fig. 8 on the monitor 14 based on the read-out image data (step S48). The monitor 14 illustrated in Fig. 8 displays the broadband image 72, which is a normal light image, and the absolute value oxygen saturation level image 73 simultaneously in juxtaposition. When the image selector switch 68 switches the screen images (step S50), the monitor 14 displays the broadband image 72, which is a normal light image, and the relative value oxygen saturation level image 74 simultaneously in juxtaposition (step S52). The operator may switch between the absolute value oxygen saturation level image 73 and the relative value oxygen saturation level image 74 as he/she desires. Alternatively, the three images, i.e., the broadband image 72, the absolute value oxygen saturation level image 73, and the relative value oxygen saturation level image 74 may all be simultaneously displayed on the monitor 14 as illustrated in Fig. 9.

[0078] As compared with the electronic endoscope system according to the above first embodiment of the invention illustrated in Fig. 2, the second embodiment uses the absolute value blood vessel depth information to determine whether a blood vessel region of interest is a superficial-layer blood vessel region (micro-blood vessel region) or a non-superficial-layer blood vessel region (intermediate-layer blood vessel or deep-layer blood vessel) for all the pixels in the blood vessel region and automatically uses the non-superficial-layer blood vessel region as a reference value region. The second embodiment basically has the same configuration as the first embodiment. Thus, like components are given like reference characters, and drawings and detailed descriptions thereof will be omitted.

[0079] The electronic endoscope system according to the second embodiment operates similarly to the electronic endoscope system according to the first embodiment. Thus, redundant descriptions will not be made below, focusing on unshared features, which are the steps S10 and S38 in the flowchart illustrated in Figs. 11 and 12.

[0080] According to the second embodiment of the invention, when the operator selects the special light image mode at the console 23 in the step S10, this automatically starts the freeze operation (still image) or, where a moving image is outputted, the output of the CCD 44 sequentially undergoes real-time processing.

[0081] In the step S38, the reference value region setter 210 uses the absolute value blood vessel depth in-

formation for all the pixels in the blood vessel region acquired in the step S32 to determine whether a blood vessel region of interest is a superficial-layer blood vessel region (micro-blood vessel region) or a non-superficial-layer blood vessel region (intermediate-layer blood vessel or deep-layer blood vessel), and automatically designates the non-superficial-layer blood vessel region as the reference value region. The reference value region may be the whole non-superficial-layer blood vessel region or a given position in the non-superficial-layer blood vessel region or a region therein having a given size.

[0082] Whether or not a pixel of interest is a superficial-layer blood vessel region may be determined using an image signal ratio between two images acquired by illumination with light having wavelengths of 405 nm and 473 nm, respectively. More specifically, when a blood vessel of interest is a superficial-layer minuteness blood vessel, its pixel value ratio $S(405)/S(473)$ tends to be small. Therefore, selecting a region having a great pixel value ratio through a threshold processing allows identification of a non-superficial-layer blood vessel region (intermediate-layer blood vessel or deep-layer blood vessel). The superficial-layer blood vessel region (micro-blood vessel region) designates a part of a blood vessel located in a digestive tract mucosa surface of interest and having a diameter of about 10 μm to 20 μm . The non-superficial-layer blood vessel region designates a region other than the superficial-layer blood vessel region, i.e., an intermediate-layer blood vessel region and a deep-layer blood vessel region. The intermediate-layer blood vessel has a diameter of about 20 μm to 100 μm ; the deep-layer blood vessel has a diameter of about 100 μm or greater.

[0083] Thereafter, as in the case of the first embodiment, the reference value oxygen saturation level information is obtained, and the relative value oxygen saturation level information is obtained from the difference between the absolute value oxygen saturation level information and the reference value oxygen saturation level information to produce the relative value oxygen saturation level image.

[0084] As described above, the second embodiment eliminates the need for the operator to set the reference value region by enabling automatic designation of the non-superficial-layer blood vessel region as the reference value region.

[0085] Fig. 13 is a block diagram illustrating a configuration of an electronic endoscope system 110, a third embodiment of the invention different from the first and the second embodiments described above.

[0086] As compared with the electronic endoscope system according to the second embodiment of the invention illustrated in Fig. 2, the electronic endoscope system 110 uses a broadband light source and an optical filter in the illumination light source to produce three kinds of narrowband light having different wavelengths from those used in the second embodiment but otherwise basically has a similar configuration. Thus, like components

are given like reference characters, and detailed descriptions thereof will be omitted.

[0087] A filter selector 202 is provided to switch between optical filter regions and receive the broadband light BB emitted from the broadband light source 30 and focused by the condenser lens 39. The filter selector 202 causes the first to the third narrowband light N1 to N3 to be produced by switching between the optical filter and switches between the first to the third narrowband light N1 to N3 and the broadband light BB. The first to the third narrowband light N1 to N3 used in the electronic endoscope system 110 have central wavelengths of 540 nm, 560 nm, and 500 nm, respectively.

[0088] The optical filter may for example be a rotary filter 130 as illustrated in Fig. 14. The rotary filter 130 comprises a broadband light transmission region 131 for passing the broadband light BB from the broadband light source 30 as it is, a first narrowband light transmission region 132 for passing the first narrowband light N1 out of the broadband light BB, a second narrowband light transmission region 133 for passing the second narrowband light N2 out of the broadband light BB, and a third narrowband light transmission region 134 for passing the third narrowband light N3 out of the broadband light BB. The rotary filter 130 is capable of rotation and turned so as to place the broadband light transmission region 131 on the optical path of the broadband light source 30 to produce the broadband light BB and place one of the first to the third narrowband light transmission regions 132 to 134 on the optical path of the broadband light source 30 to produce the corresponding one of the first narrowband light N1 to N3.

[0089] The electronic endoscope system 110 according to the third embodiment operates basically similarly to the electronic endoscope system according to the second embodiment. Thus, redundant descriptions will not be made, focusing instead on unshared features, which are the steps S26 onward in the flowchart illustrated in Figs. 11 and 12.

[0090] According to the third embodiment of the invention, the luminance ratio calculator 60 calculates a third luminance ratio $S3^*/S1^*$ in lieu of the step S26.

[0091] The third luminance ratio $S3^*/S1^*$ is an image signal ratio at a given pixel between two images acquired by illumination of light having wavelengths of 500 nm and 540, respectively. The pixel value ratio $S(500)/S(540)$ tends to be particularly small in the case of a thick blood vessel located in an intermediate or deeper layer. The thick blood vessel here denotes a blood vessel having a diameter of 100 μm or more located in an intermediate or deeper layer (in a depth of 100 μm or more) of a digestive tract mucosa of interest.

[0092] The reference value region setter 210 performs threshold processing of all the pixels in the blood vessel region in respect of the third luminance ratio to identify a region whose third luminance ratio is small. That is, the processing determines whether a pixel of interest belongs to a thick blood vessel (deep-layer blood vessel)

region. Next, out of the blood vessel region, said thick blood vessel region is automatically designated as a reference value region. The reference value region may be the whole thick blood vessel region or a given position in the thick blood vessel region or a region therein having a given size.

[0093] Next, the luminance ratio calculator 60 calculates a fourth luminance ratio $S1^*/S2^*$ for the thick blood vessel region set as the reference value region. The fourth luminance ratio $S1^*/S2^*$ is an image signal ratio at a given pixel between two images acquired by illumination of light having wavelengths of 540 nm and 560 nm, respectively. The pixel value ratio $S(540)/S(560)$ tends to increase with the oxygen saturation level.

[0094] The thick blood vessel region is either an artery or a vein and when in normal state typically has an oxygen saturation level of about 100 % and 70 %, respectively. Therefore, the distribution of the fourth luminance ratio in the reference value region is obtained, and a mean value of the upper 20% is assigned to an oxygen saturation level of 100% while the lower 20% is assigned to an oxygen saturation level of 70%, which are used respectively as first reference value oxygen saturation level information and second reference value oxygen saturation level information. Thus, an artery is expressed in a relative value with respect to the first reference value oxygen saturation level information as a reference; a vein is expressed in a relative value with respect to the second reference value oxygen saturation level information as a reference. The other part than the artery and the vein are for example assigned relative values obtained by dividing the difference between the values of the first and the second reference value oxygen saturation level information at equal intervals to produce the relative value oxygen saturation level image for the whole blood vessel region.

[0095] Fig. 15 is a block diagram illustrating a configuration of an electronic endoscope system 120, a fourth embodiment not according to the invention, different from the first to the third embodiments described above.

[0096] As compared with the electronic endoscope system according to the first embodiment illustrated in Fig. 2, the electronic endoscope system 120 basically has the same configuration except that the broadband light directly illuminates the inside of a body cavity and that images of the R-channel and the G-channel of the CCD are used in lieu of those acquired using the narrowband light. Thus, like components are given like reference characters, and detailed descriptions thereof will be omitted below.

[0097] Similar to the oxygen saturation level image producer 64 in the first embodiment, a blood level image producer 212 has a color map 212a (CM) where color information is assigned according to the blood level. The blood level image producer 212 determines color information corresponding to a signal ratio G/R (absolute value blood level information) calculated by the luminance ratio calculator 60 using the color map 212a.

[0098] When all the pixels in the blood vessel region have been assigned color information, the blood level image producer 212 reads out broadband image data from the frame memory 56 and incorporates the color information in the read-out broadband image data. Thus, the absolute value blood level image data incorporating absolute value blood level information is produced.

[0099] As described above, the electronic endoscope system 120 according to the fourth embodiment operates basically similarly to the electronic endoscope system according to the first embodiment except that the broadband light directly illuminates the inside of the body cavity and that images of the R-channel and the G-channel of the CCD are used in lieu of those acquired using the narrowband light. Thus, descriptions will be made below omitting redundancies.

[0100] According to the fourth embodiment not according to the invention, the broadband light emitted from the broadband light source 30 illuminates the inside of the body cavity, whereupon the operator operates the console 23 to perform freeze operation for acquiring a still image and obtain a broadband imaging signal as in the normal light image mode according to the first embodiment.

[0101] The luminance ratio calculator 60 calculates the signal ratio G/R , a pixel value ratio between an imaging signal G and an imaging signal R of the acquired broadband imaging signal. The signal ratio G/R is the absolute value blood level information and corresponds to the absolute value oxygen saturation level information in the first embodiment. The image data composed of imaging signal G and the imaging signal R correspond to the first and the second narrowband image data in the first embodiment, respectively.

[0102] The signal ratio G/R is an image signal ratio between two images of the R channel and the G channel of the CCD 44 and tends to decrease as the blood level increases, that is, as the hemoglobin concentration in blood increases. The absolute value blood level information may be the logarithm of the signal ratio G/R as well as the signal ratio G/R .

[0103] Thereafter, as in the first embodiment, the blood level image producer 212 produces the absolute value blood level image data. Then, the operator operates the console 23 to cause the reference value region setter 210 to set the reference value region, thus producing the reference value blood level information from a mean value of the absolute value blood level information in the reference value region. Further, the difference between the absolute value blood level information and the reference value blood level information in the whole blood vessel region is calculated to produce the relative value blood level information and, hence, the relative value blood level image, a simulated color image, may be produced.

[0104] As described above, the first embodiment of the invention allows the simulated color display of the oxygen saturation level to be switched as desired between the

absolute value display mode and the relative value display mode according to the input made by the operator. The second embodiment of the invention automatically identifies the non-superficial-layer blood vessel region and designates it as the reference value region and permits simulated color display of the relative value oxygen saturation level. Further, the third embodiment of the invention identifies the thick blood vessel region and permits simulated color display of the relative value oxygen saturation level of the thick blood vessel region to allow easy distinction between an artery and a vein. Further, the fourth embodiment not according to the invention allows the simulated color display of the blood level to be switched as desired between the absolute value display mode and the relative value display mode according to the input made by the operator. Such relative value display permits improvement of the robustness of the oxygen saturation level and the blood level.

[0105] Although the first to the third narrowband light sources are used to obtain the blood vessel depth and the oxygen saturation level according to the first and the second embodiments, a fourth narrowband light source for producing a fourth narrowband light N4 having a wavelength limited to a proximity of 532 nm may be added in order to produce the first to the fourth narrowband image data by illumination with the first to the fourth narrowband light N1 to N4, so that the blood vessel depth and the oxygen saturation level may be obtained based on these image data. Because light reaches an increasingly deeper layer as its wavelength grows longer, information on a blood vessel located at a still deeper position may be obtained using the fourth narrowband light N4 having a wavelength longer than that of the second narrowband light N2.

[0106] In this case, the luminance ratio calculator 60 determines the blood vessel region from the first to the fourth narrowband image data. Further, as in the first embodiment, the first and the second luminance ratios $S1/S3$ and $S2/S3$ are obtained as well as the third luminance ratio $S4/S3$, which is a luminance ratio between the first and the fourth narrowband image data. $S4$ is the luminance value of a pixel in the fourth narrowband image data. The blood vessel depth-oxygen saturation level calculator 62 calculates the blood vessel depth information and the oxygen saturation level information corresponding to the first to the third luminance ratios calculated by the luminance ratio calculator 60 through the same procedure as in the first embodiment based on the correlation, previously obtained by conducting experiment and the like, between the first to the third luminance ratios $S1/S3$, $S2/S3$, and $S4/S3$ and the blood vessel depth and oxygen saturation level.

[0107] The number of frames of the imaging signal may be reduced by achieving imaging with illumination using synthesized light obtained by combining two or more of the first to the fourth narrowband light N1 to N4 in lieu of executing imaging each time illumination is effected by the first to the fourth narrowband light N1 to N4. For ex-

ample, the inside of the body cavity may first be imaged by simultaneous illumination with the first narrowband light N1 and the fourth narrowband N4. The inside of the body cavity may then be imaged by simultaneous illumination with the second narrowband light N2 and the third narrowband N3. Thus, a total of two frames of imaging signals are obtained.

[0108] The imaging signal obtained by the first imaging comprises an imaging signal B1 and an imaging signal G1 having the following luminance values, respectively. The imaging signal obtained by the next imaging comprises an imaging signal B2 and an imaging signal G2 having the following luminance values, respectively.

[0109] The imaging signal B1 has a luminance value $L1 + L4$, where $L1$ is the luminance value resulting from the first narrowband light N1, and $L4$ is the luminance value resulting from the fourth narrowband light N4.

[0110] The imaging signal G1 has a luminance value $L4$, which is the luminance value resulting from the fourth narrowband light N4.

[0111] The imaging signal B2 has a luminance value $L2 + L3$, where $L2$ is the luminance value resulting from the second narrowband light N2, and $L3$ is the luminance value resulting from the third narrowband light N3.

[0112] The imaging signal G2 has a luminance value $L2$, which is the luminance value resulting from the second narrowband light N2.

[0113] The imaging signal G2 having only the luminance value $L2$ yields the second narrowband image data; the imaging signal G1 having only the luminance value $L4$ yields the fourth narrowband image data. Computation of $B1 - (\text{constant}) \times G1$ separates the luminance value $L4$ from the imaging signal B1, producing the first narrowband image data. The constant is determined from the intensity ratio between the first narrowband light N1 and the fourth narrowband light N4. Further, computation of $B2 - (\text{constant}) \times G2$ separates the luminance value $L3$ from the imaging signal B2, producing the second narrowband image data. The constant is determined from the intensity ratio between the second narrowband light N2 and the third narrowband light N3.

[0114] Although, according to the first and the fourth embodiments, the operator sets the reference value region after the absolute value oxygen saturation level image or the absolute value blood level image is once displayed, the procedure may be such that the operator sets the reference value region on the broadband image before the absolute value oxygen saturation level image or the absolute value blood level image is displayed. According to the second embodiment, in lieu of the display order in which the broadband image is first displayed, and then the absolute value oxygen saturation level image, followed by the relative value oxygen saturation level image, the broadband image may be followed by the relative value oxygen saturation level image in the order of display.

[0115] Although the first and the second embodiments use the first to the third narrowband light sources to pro-

duce the first to the third narrowband light N1 to N3, the first to the third narrowband light N1 to N3 may be produced using the rotary filter 130 illustrated in Fig. 14 as in the third embodiment without providing the first to the third narrowband light sources.

[0116] The present invention may be applied not only to an insertion type electronic endoscope comprising an insertion section as described above but also to a capsule type electronic endoscope comprising an image sensor and the like such as a CCD incorporated in a capsule.

[0117] While the electronic endoscope system, the electronic endoscope processor, and the method of acquiring blood vessel information according to the present invention have been described above in detail, the present invention is by no means limited to the above embodiments and various improvements and modifications may of course be made without departing from the scope as defined in the claims.

Claims

1. An electronic endoscope system (10) comprising:

light source device (13) for illuminating a subject tissue located in a body cavity and containing a blood vessel with illumination light, said light source device being configured to emit first to third narrowband lights (N1,N2,N3) having different wavelengths,

an electronic endoscope (11) configured to guide the first to third narrowband lights to the subject tissue, including an image sensor (44) for receiving reflected light of said first to third narrowband lights from the subject tissue, said image sensor (44) being configured to acquire images of the subject tissue, and to output narrowband imaging signals representing a luminance of the respective narrowband reflected light,

a digital signal processor (55) configured to produce first to third narrowband image data from the first to the third narrowband imaging signals,

a blood vessel information producing means and reference value blood vessel information calculating means for producing blood vessel information on the blood vessel from the first to third narrowband image data, comprising

a luminance ratio calculator (60) configured to determine a blood vessel region containing a blood vessel from the first to the third narrowband image data, wherein the luminance ratio calculator (60) is configured to obtain a first luminance ratio (S1/S3) between the first and the third narrowband image data and a second luminance ratio (S2/S3) between the second and the third narrowband image data

corresponding to a pixel at the same position in the blood vessel region,

a correlation storage (61) configured to store a correlation between the first and the second luminance ratio on the one hand and an oxygen saturation level in a blood vessel and a blood vessel depth on the other hand,

a blood vessel depth-oxygen saturation level calculator (62) configured to determine the oxygen saturation level and the blood vessel depth corresponding to the first and the second luminance ratios based on the correlation stored in the correlation storage (61),

a reference value region setter (210) for setting a given region in an image acquired by the image sensor (44) as a reference value region,

wherein the blood vessel depth-oxygen saturation calculator (62) is configured to obtain a reference value for the blood vessel depth information and a reference value oxygen saturation level information for the reference value region and configured to obtain an absolute blood vessel depth information and an absolute value oxygen saturation level information for the whole imaged blood vessel region,

a relative value image producer (200) configured to obtain a relative value oxygen saturation level information from a difference between the absolute value oxygen saturation level information and the reference value oxygen saturation level information,

wherein the relative value image producer (200) is configured to produce relative value oxygen saturation level image data and

an image displaying means (56,58,14) configured to display a relative value oxygen saturation level image (34) produced by the relative value image producer (200).

2. The electronic endoscope system (10) according to claim 1,

wherein the luminance ratio calculator (60) includes an oxygen saturation level image producer (64) adapted to produce an absolute value oxygen saturation level information image (73) representing an absolute value of the oxygen saturation level information in simulated color from the oxygen saturation level information determined by the blood vessel depth-oxygen saturation level calculator (62),

wherein the electronic endoscope system (10) further comprises an image switching means (68) for switching between the absolute value oxygen saturation level information image (73) and the relative value oxygen saturation level information image (74), and

wherein the image displaying means (56, 58,

14) displays one of the absolute value oxygen saturation level information image (73) and the relative value oxygen saturation level information image (74) selected by the image switching means (68).

3. The electronic endoscope system (10) according to claim 1, wherein the first and the second narrowband light (N1, N2) exhibit different absorbances for oxygenated hemoglobin, which is combined with oxygen, and reduced hemoglobin, which is not combined with oxygen, and include wavelengths producing a difference in absorbance by each hemoglobin according to oxygen saturation level.

4. The electronic endoscope system (10) according to claim 3, wherein the first narrowband light (N1) has a wavelength range of 440 nm plus or minus 10 nm, the second narrowband light (N2) has a wavelength range of 470 nm plus or minus 10 nm, and the third narrowband light (N3) has a wavelength range of 400 nm plus or minus 10 nm.

5. The electronic endoscope system (10) according to claim 1, wherein the reference value region setter (210) is adapted to distinguish between superficial-layer blood vessel region and a non-superficial-layer blood vessel region from the depth information of the blood vessel, and to thereby set the non-superficial-layer blood vessel region as the reference value region.

6. The electronic endoscope system according to claim 4, wherein the reference value region setter (210) is adapted to calculate a signal ratio between the second and the third narrowband signals, to distinguish between superficial-layer blood vessel region and a non-superficial-layer blood vessel region from the signal ratio between the second and the third narrowband signals, and to thereby set the non-superficial-layer blood vessel region as the reference value region.

7. The electronic endoscope system according to claim 3.

wherein the first narrowband light has a wavelength range of 540 nm plus or minus 10 nm, the second narrowband light has a wavelength range of 560 nm plus or minus 10 nm, and the third narrowband light has a wavelength range of 500 nm plus or minus 10 nm, wherein the blood vessel information producing means is adapted to calculate a third luminance ratio (S3*, S1*) between two narrowband image data, the reference value region setter is adapted to identify a thick blood vessel region based on the

5

10

15

20

25

30

35

40

45

50

55

third luminance ratio (S3*, S1*), and to set the thick blood vessel region as the reference value region, and

the blood vessel information producing means is further adapted to calculate a fourth luminance ratio (S1*, S2*) between two narrowband image data respectively corresponding to the first and the second narrowband signals, and wherein the luminance ratio calculator (60) includes an oxygen saturation level image producer (64) adapted to produce the relative value oxygen saturation level information image (74) based on a distribution of the fourth luminance ratio.

8. A method of acquiring blood vessel information, comprising

an illuminating step (S14,S18,S22)of illuminating a subject tissue located in a body cavity and containing a blood vessel with first to third narrowband lights (N1,N2,N3) having different wavelength bands as illumination light respectively,

an imaging step of imaging an image of the subject tissue by receiving reflected light of first to third narrowband lights (N1,N2,N3) with which the subject tissue has been illuminated in the illuminating step to acquire narrowband imaging signals corresponding to the plurality of narrowband light having the different wavelength bands, respectively and representing a luminance of the reflected light of the first to third narrowband lights (N1,N2,N3),

an image data producing digital signal processing step (S16, S20, S24) of producing first to third narrowband image data from the first to the third narrowband imaging signals obtained at the imaging step,

a reference value region setting step (38) of setting a given region in an image of the blood vessel acquired at imaging step as reference value region based on the depth information of the blood vessel or the diameter information of the blood vessel produced by the blood vessel information producing step,

a blood vessel information producing and reference value blood vessel information calculating step (S28) of producing blood vessel information on the blood vessel, comprising

a luminance ratio calculating step (S26) of determining a blood vessel region containing a blood vessel from the first to the third narrowband image data produced at digital signal processing step, wherein the digital signal processing step obtains a first luminance ratio (S1/S3) between the first and the third narrowband image data and a second luminance ratio

(S2/S3) between the second and the third narrowband image data corresponding to a pixel at the same position in the blood vessel region; a correlation storing step of storing a correlation between the first and the second luminance ratio on the one hand and an oxygen saturation level in a blood vessel and a blood vessel depth on the other hand; and

a blood vessel depth-oxygen saturation level calculating step of determining the oxygen saturation level and the blood vessel depth corresponding to the first and the second luminance ratios based on the correlation stored at the correlation staging step,

a reference value oxygen saturation level information calculating step (S40) of calculating a reference value for the oxygen saturation level information in the blood vessel region based on the oxygen saturation level of the reference value region set by the reference value region setting step (S38) to acquire reference value oxygen saturation level information,

a relative value oxygen saturation level information calculating step (S44) of calculating relative value oxygen saturation level information in the blood vessel region from a difference between the oxygen saturation level information and the reference value oxygen saturation level information calculated by the reference value oxygen saturation level information calculating step,

a relative image producing step of producing relative value oxygen saturation level image data by obtaining a relative value oxygen saturation level information from a difference between the absolute value oxygen saturation level information and the reference value oxygen saturation level information,

an image displaying step (s52) of displaying the relative value oxygen saturation level image produced by the relative image producing step.

Patentansprüche

1. Elektronisches Endoskopsystem (10), umfassend:
 - eine Lichtquelleneinrichtung (13) zum Beleuchten eines in einem Körperhohlraum befindlichen Subjektgewebes, das ein Blutgefäß enthält, mit Beleuchtungslicht, wobei die Lichtquelleneinrichtung konfiguriert ist zum Emittieren von erstem bis drittem schmalbandigen Licht (N1, N2, N3) unterschiedlicher Wellenlängen,
 - ein elektronisches Endoskop (11) konfiguriert zum Leiten des ersten bis dritten schmalbandigen Lichts zu dem Subjektgewebe, enthaltend einen Bildsensor (44) zum Empfangen reflektierten Lichts von dem ersten bis dritten schmal-

bandigen Licht von dem Subjektgewebe, wobei der Bildsensor (44) konfiguriert ist zum Erfassen von Bildern des Subjektgewebes und zum Ausgeben schmalbandiger Bildsignale, die eine Luminanz des betreffenden schmalbandigen reflektierten Lichts repräsentieren, einen digitalen Signalprozessor (55), konfiguriert zum Erzeugen von ersten bis dritten schmalbandigen Bilddaten aus den ersten bis dritten schmalbandigen Bildsignalen, eine Blutgefäßinformations-Erzeugungseinrichtung und eine Referenzwert-Blutgefäßinformations-Berechnungseinrichtung zum Erzeugen von Blutgefäßinformation bezüglich des Blutgefäßes aus den ersten bis dritten schmalbandigen Bilddaten, umfassend:

einen Luminanzverhältnisrechner (60), konfiguriert zum Bestimmen einer Blutgefäßzone, die ein Blutgefäß enthält, aus den ersten bis dritten schmalbandigen Bilddaten, wobei der Luminanzverhältnisrechner (60) konfiguriert ist zum Gewinnen eines ersten Luminanzverhältnisses (S1/S3) zwischen den ersten und den dritten schmalbandigen Bilddaten, und eines zweiten Luminanzverhältnisses (S2/S3) zwischen den zweiten und den dritten schmalbandigen Bilddaten entsprechend einem Pixel gleicher Stelle innerhalb der Blutgefäßzone, einen Korrelationsspeicher (61), konfiguriert zum Speichern einer Korrelation zwischen dem ersten und dem zweiten Luminanzverhältnis einerseits und einem Sauerstoffsättigungswert in einem Blutgefäß sowie eine Blutgefäßtiefe, andererseits, einen Blutgefäßtiefen-Sauerstoffsättigungswert-Rechner (62), konfiguriert zum Bestimmen des Sauerstoffsättigungswerts und der Blutgefäßtiefe entsprechend dem ersten und dem zweiten Luminanzverhältnis, basierend auf der in dem Korrelationsspeicher (61) gespeicherten Korrelation, einen Referenzwertzonen-Einsteller (210) zum Einstellen einer gegebenen Zone innerhalb eines von dem Bildsensor (44) erfassten Bilds als eine Referenzwertzone, wobei der Blutgefäßtiefen-Sauerstoffsättigungswert-Rechner (62) konfiguriert ist zum Gewinnen eines Referenzwerts für Blutgefäßtiefen-Information und einer Referenzwert-Sauerstoffsättigungswert-Information für die Referenzwertzone, außerdem konfiguriert zum Gewinnen einer Absolut-Blutgefäßtiefen-Information und einer Absolutwert-Sauerstoffsättigungswert-Information für die gesamte abgebildete Blutgefäßzone,

- einen Relativwert-Bilderzeuger (200), konfiguriert zum Gewinnen einer Relativwert-Sauerstoffsättigungswert-Information aus einer Differenz zwischen der Absolutwert-Sauerstoffsättigungswert-Information und der Referenzwert-Sauerstoffsättigungswert-Information, wobei der Relativwert-Bilderzeuger (200) konfiguriert ist zum Erzeugen von Relativwert-Sauerstoffsättigungswert-Bilddaten und eine Bildanzeigeeinrichtung (56, 58, 14), konfiguriert zum Anzeigen eines Relativwert-Sauerstoffsättigungswert-Bilds (34), das von dem Relativwert-Bilderzeuger (200) erzeugt wurde.
2. Elektronisches Endoskopsystem (10) nach Anspruch 1, bei dem der Luminanzverhältnisrechner (60) einen Sauerstoffsättigungswert-Bilderzeuger (64) enthält, ausgebildet zum Erzeugen eines Absolutwert-Sauerstoffsättigungswert-Informationsbilds (73), das einen Absolutwert der Sauerstoffsättigungswert-Information in simulierter Farbe aus der Sauerstoffsättigungswert-Information repräsentiert, die von dem Blutgefäßtiefen-Sauerstoffsättigungswert-Rechner (62) erzeugt wird, wobei das elektronische Endoskopsystem (10) weiterhin eine Bildumschalteneinrichtung (68) aufweist, um umzuschalten zwischen dem Absolutwert-Sauerstoffsättigungswert-Informationsbild (73) und dem Relativwert-Sauerstoffsättigungswert-Informationsbild (74), und wobei die Bildanzeigeeinrichtung (56, 58, 14) eines von dem Absolutwert-Sauerstoffsättigungswert-Informationsbild (73) und dem Relativwert-Sauerstoffsättigungswert-Informationsbild (74) anzeigt, das von der Bildumschalteneinrichtung (68) ausgewählt wurde.
 3. Elektronisches Endoskopsystem (10) nach Anspruch 1, bei dem das erste und das zweite schmalbandige Licht (N1, N2) unterschiedliche Absorptionsvermögen für sauerstoffreiches Hämoglobin, das mit Sauerstoff kombiniert ist, und für reduziertes Hämoglobin, welches nicht mit Sauerstoff kombiniert ist, aufweist, und Wellenlängen enthalten, die eine Differenz im Absorptionsvermögen durch jedes Hämoglobin nach Maßgabe des Sauerstoffsättigungswerts erzeugen.
 4. Elektronisches Endoskopsystem (10) nach Anspruch 3, bei dem das erste schmalbandige Licht (N1) einen Wellenlängenbereich von 440 nm plus oder minus 10 nm aufweist, das zweite schmalbandige Licht (N2) einen Wellenlängenbereich von 470 nm plus oder minus 10 nm aufweist, und das dritte schmalbandige Licht (N3) einen Wellenlängenbereich von 400 nm plus oder minus 10 nm besitzt.
 5. Elektronisches Endoskopsystem (10) nach Anspruch 1, bei dem der Referenzwertzonen-Einsteller (210) dazu ausgebildet ist, zu unterscheiden zwischen einer Oberflächenschicht-Blutgefäßzone und einer Nicht-Oberflächenschicht-Blutgefäßzone anhand der Tiefeninformation des Blutgefäßes, um dadurch die Nicht-Oberflächenschicht-Blutgefäßzone als die Referenzwertzone einzustellen.
 6. Elektronisches Endoskopsystem nach Anspruch 4, bei dem der Referenzwertzonen-Einsteller (210) dazu ausgebildet ist, ein Signalverhältnis zwischen den zweiten und den dritten schmalbandigen Signalen zu berechnen, zu unterscheiden zwischen der Oberflächenschicht-Blutgefäßzone und einer Nicht-Oberflächenschicht-Blutgefäßzone anhand des Signalverhältnisses zwischen den zweiten und den dritten schmalbandigen Signalen, und dadurch eine Nicht-Oberflächenschicht-Blutgefäßzone als die Referenzwertzone einzustellen.
 7. Elektronisches Endoskopsystem nach Anspruch 3, bei dem das erste schmalbandige Licht einen Wellenlängenbereich von 540 nm plus oder minus 10 nm, das zweite schmalbandige Licht einen Wellenlängenbereich von 560 nm plus oder minus 10 nm, und das dritte schmalbandige Licht einen Wellenlängenbereich von 500 nm plus oder minus 10 nm besitzt, wobei die Blutgefäßinformation-Erzeugungseinrichtung dazu ausgebildet ist, ein drittes Luminanzverhältnis ($S3^*$, $S1^*$) zwischen zwei schmalbandigen Bilddaten zu berechnen, der Referenzwertzonen-Einsteller ausgebildet ist zum Identifizieren einer Dickenblutgefäßzone basierend auf dem dritten Luminanzverhältnis ($S3^*$, $S1^*$), und zum Einstellen der Dickenblutgefäßzone als die Referenzwertzone, und die Blutgefäßinformations-Erzeugungseinrichtung weiterhin ausgebildet ist zum Berechnen eines vierten Luminanzwerts ($S1^*$, $S2^*$) zwischen zwei schmalbandigen Bilddaten entsprechend den ersten bzw. den zweiten schmalbandigen Signalen, und wobei der Luminanzverhältnisrechner (60) einen Sauerstoffsättigungswert-Bilderzeuger (64) aufweist, ausgebildet zum Erzeugen des Relativwert-Sauerstoffsättigungswert-Informationsbilds (74) auf der Grundlage einer Verteilung des vierten Luminanzverhältnisses.
 8. Verfahren zum Erfassen von Blutgefäßinformation, umfassend:
 - einen Beleuchtungsschritt ($S14$, $S18$, $S22$) des Beleuchtens eines Subjektgewebes in einem

Körperhohlraum, welches Gewebe ein Blutgefäß enthält, mit erstem bis drittem schmalbandigen Licht (N1, N2, N3) unterschiedlicher Wellenlängenbänder als Beleuchtungslicht, 5
 einen Bildgebungsschritt des Aufnehmens eines Bilds des Subjektgewebes durch Empfangen von reflektiertem Licht des ersten bis dritten schmalbandigen Lichts (N1, N2, N3), mit welchem das Subjektgewebe in dem Beleuchtungsschritt beleuchtet wurde, um schmalbandige Bildsignale entsprechend den mehreren 10
 Teilen des schmalbandigen Lichts unterschiedlicher Wellenlängenbänder zu erfassen, und zum Repräsentieren einer Luminanz des reflektierten Lichts von dem ersten bis dritten schmalbandigen Licht (N1, N2; N3), 15
 einen Bilddatenerzeugungsschritt-Digitalsignal-Verarbeitungsschritt (S16, S20, S24) des Erzeugens von ersten bis dritten schmalbandigen Bilddaten aus den ersten bis dritten schmalbandigen Bildsignalen, die in dem Bildgebungsschritt erhalten wurden, 20
 einen Referenzwertzonen-Einstellschritt (S38) des Einstellens einer gegebenen Zone in einem Bild des Blutgefäßes, welches in dem Bildgebungsschritt erfasst wurde, als Referenzwertzone, basierend auf der Tiefeninformation des Blutgefäßes oder der Durchmesserinformation des Blutgefäßes, die von dem Blutgefäßinformations-Erzeugungsschritt erzeugt wurde, 25
 einen Blutgefäßinformations-Erzeugungs- und Referenzwert-Blutgefäßinformations-Berechnungsschritt (S28) des Erzeugens von Blutgefäßinformation über das Blutgefäß, umfassend: 30

einen Luminanzverhältnis-Berechnungsschritt (S26) des Bestimmens einer Blutgefäßzone, die ein Blutgefäß enthält, aus den ersten bis dritten schmalbandigen Bilddaten, die in dem Digitalsignal-Verarbeitungsschritt erzeugt wurden, wobei der Digitalsignal-Erzeugungsschritt ein erstes Luminanzverhältnis (S1/S3) zwischen den ersten und den dritten schmalbandigen Bilddaten und ein zweites Luminanzverhältnis (S2/S3) zwischen den zweiten und den dritten schmalbandigen Bilddaten entsprechend einem Pixel an der gleichen Position innerhalb der Blutgefäßzone ermittelt; 35
 einen Korrelationspeicherschritt des Speicherns einer Korrelation zwischen dem ersten und dem zweiten Luminanzverhältnis einerseits, und einem Sauerstoffsättigungswert in einem Blutgefäß und einer Blutgefäßtiefe, andererseits; und 40
 einen Blutgefäßtiefen-Sauerstoffsättigungswert-Berechnungsschritt des Bestimmens des Sauerstoffsättigungswerts 45

und der Blutgefäßtiefe entsprechend dem ersten bzw. dem zweiten Luminanzverhältnis, basierend auf der in dem Korrelationspeicherschritt gespeicherten Korrelation, einen Referenzwert-Sauerstoffsättigungswert-Informations-Berechnungsschritt (S40) des Berechnens eines Referenzwertes für die Sauerstoffsättigungswert-Information in der Blutgefäßzone, basierend auf dem Sauerstoffsättigungswert der Referenzwertzone, die in dem Referenzwertzonen-Einstellschritt (S38) eingestellt wurde, um Referenzwert-Sauerstoffsättigungswert-Information zu erfassen, 5
 einen Relativwert-Sauerstoffsättigungswertinformation-Berechnungsschritt (S44) des Berechnens von Relativwert-Sauerstoffsättigungswert-Information in der Blutgefäßzone aus einer Differenz zwischen der Sauerstoffsättigungswert-Information und der Referenzwert-Sauerstoffsättigungswert-Information, die von dem Referenzwert-Sauerstoffsättigungswert-Information-Berechnungsschritt berechnet wurde, 10
 einen Relativbild-Erzeugungsschritt des Erzeugens von Relativwert-Sauerstoffsättigungswert-Bilddaten durch Ermitteln von Relativwert-Sauerstoffsättigungswert-Information aus einer Differenz zwischen der Absolutwert-Sauerstoffsättigungswert-Information und der Referenzwert-Sauerstoffsättigungswert-Information, und 15
 einen Bildanzeigeschritt (S52) des Anzeigens des Relativwert-Sauerstoffsättigungswert-Bilds, das von dem Relativbild-Erzeugungsschritt erzeugt wurde. 20

Revendications

1. Système d'endoscope électronique (10), comprenant :

un dispositif de source de lumière (13) destiné à éclairer un tissu de sujet situé dans une cavité corporelle et contenant un vaisseau sanguin avec une lumière d'éclairage, ledit dispositif de source de lumière étant configuré pour émettre des première à troisième lumières à bande étroite (N1, N2, N3) présentant des longueurs d'onde différentes ;

un endoscope électronique (11) configuré pour guider les première à troisième lumières à bande étroite vers un tissu de sujet, incluant un capteur d'image (44) pour recevoir une lumière réfléchie desdites première à troisième lumières à bande étroite à partir du tissu de sujet, ledit capteur d'image (44) étant configuré pour ac-

quérir des images du tissu de sujet et pour émettre des signaux d'imagerie à bande étroite représentant une luminance de la lumière réfléchie à bande étroite respective ;

un processeur de signaux numériques (55) configuré pour produire des premières à troisièmes données d'image à bande étroite à partir des premiers à troisièmes signaux d'imagerie à bande étroite ;

un moyen de production d'informations de vaisseau sanguin et un moyen de calcul d'informations de vaisseau sanguin de valeur de référence pour produire des informations de vaisseau sanguin sur le vaisseau sanguin à partir des premières à troisièmes données d'image à bande étroite, comprenant :

un calculateur de rapport de luminance (60) configuré pour déterminer une région de vaisseau sanguin contenant un vaisseau sanguin à partir des premières à troisièmes données d'image à bande étroite, dans lequel le calculateur de rapport de luminance (60) est configuré pour obtenir un premier

rapport de luminance (S1/S3) entre les premières et troisièmes données d'image à bande étroite et un second rapport de luminance (S2/S3) entre les deuxièmes et troisièmes données d'image à bande étroite correspondant à un pixel sur la même position dans la région de vaisseau sanguin ; un stockage de corrélation (61) configuré pour stocker une corrélation, d'une part, entre les premier et second rapports de luminance et, d'autre part, entre un niveau de saturation en oxygène dans un vaisseau sanguin et une profondeur de vaisseau sanguin,

un calculateur de niveau de saturation en oxygène et de profondeur de vaisseau sanguin (62) configuré pour déterminer le niveau de saturation en oxygène et la profondeur de vaisseau sanguin correspondant aux premier et second rapports de luminance sur la base de la corrélation stockée dans le stockage de corrélation (61) ;

un moyen de réglage de région de valeur de référence (210) pour régler une région donnée dans une image acquise par le capteur d'image (44) comme région de valeur de référence,

dans lequel le calculateur de saturation en oxygène et de profondeur de vaisseau sanguin (62) est configuré pour obtenir une valeur de référence pour les informations de profondeur de vaisseau sanguin et des informations de niveau de saturation en oxygène de valeur de référence pour la région

de valeur de référence, et configuré pour obtenir des informations de profondeur de vaisseau sanguin absolues et des informations de niveau de saturation en oxygène de valeur absolue pour toute la région de vaisseau sanguin imagée ;

un moyen de production d'image de valeur relative (200) configuré pour obtenir des informations de niveau de saturation en oxygène de valeur relative à partir d'une différence entre les informations de niveau de saturation en oxygène de valeur absolue et les informations de niveau de saturation en oxygène de valeur de référence ;

dans lequel le moyen de production d'image de valeur relative (200) est configuré pour produire des données d'image de niveau de saturation en oxygène de valeur relative, et un moyen d'affichage d'image (56, 58, 14) configuré pour afficher une image de niveau de saturation en oxygène de valeur relative (34) produite par le moyen de production d'image de valeur relative (200).

2. Système d'endoscope électronique (10) selon la revendication 1, dans lequel le calculateur de rapport de luminance (60) inclut un moyen de production d'image de niveau de saturation en oxygène (64) apte à produire une image d'informations de niveau de saturation en oxygène de valeur absolue (73) représentant une valeur absolue des informations de niveau de saturation en oxygène en couleur simulée à partir des informations de niveau de saturation en oxygène déterminées par le calculateur de niveau de saturation en oxygène et de profondeur de vaisseau sanguin (62) ; dans lequel le système d'endoscope électronique (10) comprend en outre un moyen de commutation d'image (68) pour commuter entre l'image d'informations de niveau de saturation en oxygène de valeur absolue (73) et l'image d'informations de niveau de saturation en oxygène de valeur relative (74), et dans lequel le moyen d'affichage d'image (56, 58, 14) affiche une image parmi l'image d'informations de niveau de saturation en oxygène de valeur absolue (73) et l'image d'informations de niveau de saturation en oxygène de valeur relative (74) sélectionnée par le moyen de commutation d'image (68).
3. Système d'endoscope électronique (10) selon la revendication 1, dans lequel les première et deuxième lumières à bande étroite (N1, N2) présentent des absorbances différentes pour l'oxyhémoglobine, laquelle est combinée à l'oxygène, et la désoxyhémoglobine, laquelle n'est pas combinée à l'oxygène, et incluent des longueurs d'onde produisant une différence quant à l'absorbance pour chaque hémoglo-

bine en fonction du niveau de saturation en oxygène.

4. Système d'endoscope électronique (10) selon la revendication 3, dans lequel la première lumière à bande étroite (N1) présente une plage de longueurs d'onde de 440 nm, plus ou moins 10 nm, la deuxième lumière à bande étroite (N2) présente une plage de longueurs d'onde de 470 nm, plus ou moins 10 nm, et la troisième lumière à bande étroite (N3) présente une plage de longueurs d'onde de 400 nm, plus ou moins 10 nm.
5. Système d'endoscope électronique (10) selon la revendication 1, dans lequel le moyen de réglage de région de valeur de référence (210) est apte à distinguer entre une région de vaisseau sanguin de couche superficielle et une région de vaisseau sanguin de couche non superficielle à partir des informations de profondeur du vaisseau sanguin, et ainsi à régler la région de vaisseau sanguin de couche non superficielle comme région de valeur de référence.
6. Système d'endoscope électronique selon la revendication 4, dans lequel le moyen de réglage de région de valeur de référence (210) est apte à calculer un rapport de signal entre les premiers et troisièmes signaux à bande étroite, à distinguer entre une région de vaisseau sanguin de couche superficielle et une région de vaisseau sanguin de couche non superficielle à partir du rapport de signal entre les deuxièmes et troisièmes signaux à bande étroite, et ainsi à régler la région de vaisseau sanguin de couche non superficielle comme région de valeur de référence.
7. Système d'endoscope électronique selon la revendication 3, dans lequel la première lumière à bande étroite présente une plage de longueurs d'onde de 540 nm, plus ou moins 10 nm, la deuxième lumière à bande étroite présente une plage de longueurs d'onde de 560 nm, plus ou moins 10 nm, et la troisième lumière à bande étroite présente une plage de longueurs d'onde de 500 nm, plus ou moins 10 nm, dans lequel le moyen de production d'informations de vaisseau sanguin est apte à calculer un troisième rapport de luminance (S3*, S1*) entre deux données d'image à bande étroite, le moyen de réglage de région de valeur de référence est apte à identifier une région de vaisseau sanguin épaisse sur la base du troisième rapport de luminance (S3*, S1*), et à régler la région de vaisseau sanguin épaisse comme région de valeur de référence, et le moyen de production d'informations de vaisseau sanguin est en outre apte à calculer un quatrième rapport de luminance (S1*, S2*) entre deux données d'image à bande étroite correspondant respective-

ment aux premiers et deuxièmes signaux à bande étroite, et

dans lequel le calculateur de rapport de luminance (60) inclut un moyen de production d'image de niveau de saturation en oxygène (64) apte à produire l'image d'informations de niveau de saturation en oxygène de valeur relative (74) sur la base d'une distribution du quatrième rapport de luminance.

8. Procédé destiné à acquérir des informations de vaisseau sanguin, comprenant les étapes suivantes :

une étape d'éclairage (S14, S18, S22) pour éclairer un tissu de sujet situé dans une cavité corporelle et contenant un vaisseau sanguin avec des première à troisième lumières à bande étroite (N1, N2, N3) présentant respectivement des bandes de longueurs d'onde différentes comme lumière d'éclairage ;

une étape d'imagerie pour imager une image du tissu de sujet, en recevant une lumière réfléchie parmi les première à troisième lumières à bande étroite (N1, N2, N3) avec lesquelles le tissu de sujet a été éclairé lors de l'étape d'éclairage, afin d'acquérir des signaux d'imagerie à bande étroite correspondant à la pluralité de lumières à bande étroite présentant respectivement les différentes bandes de longueurs d'onde, et représentant une luminance de la lumière réfléchie des premières à troisièmes lumières à bande étroite (N1, N2, N3) ;

une étape de traitement de signaux numériques produisant des données d'image (S16, S20, S24) pour produire des premières aux troisièmes données d'image à bande étroite à partir des premiers, deuxièmes et troisièmes signaux d'imagerie à bande étroite obtenus lors de l'étape d'imagerie ;

une étape de réglage de région de valeur de référence (S38) pour régler une région donnée dans une image du vaisseau sanguin acquise lors de l'étape d'imagerie comme région de valeur de référence sur la base des informations de profondeur du vaisseau sanguin ou des informations de diamètre du vaisseau sanguin produites lors de l'étape de production d'informations de vaisseau sanguin ;

une étape de production d'informations de vaisseau sanguin et de calcul d'informations de vaisseau sanguin de valeur de référence (S28) pour produire des informations de vaisseau sanguin sur le vaisseau sanguin, comprenant :

une étape de calcul de rapport de luminance (S26) pour déterminer une région de vaisseau sanguin contenant un vaisseau sanguin à partir des premières à troisièmes données d'image à bande étroite produites

lors de l'étape de traitement de signaux numériques, l'étape de traitement de signaux numériques obtenant un premier rapport de luminance (S1/S3) entre les premières et troisièmes données d'image à bande étroite et un second rapport de luminance (S2/S3) entre les deuxièmes et troisièmes données d'image à bande étroite correspondant à un pixel sur la même position dans la région de vaisseau sanguin ;

une étape de stockage de corrélation pour stocker une corrélation, d'une part, entre les premier et second rapports de luminance et, d'autre part, entre un niveau de saturation en oxygène dans un vaisseau sanguin et une profondeur de vaisseau sanguin,

une étape de calcul de niveau de saturation en oxygène et de profondeur de vaisseau sanguin pour déterminer le niveau de saturation en oxygène et la profondeur de vaisseau sanguin correspondant aux premier et second rapports de luminance sur la base de la corrélation stockée dans l'étape de stockage de corrélation ;

une étape de calcul d'informations de niveau de saturation en oxygène de valeur de référence (S40) pour calculer une valeur de référence pour les informations de niveau de saturation en oxygène dans la région de vaisseau sanguin sur la base du niveau de saturation en oxygène de la région de valeur de référence réglée lors de l'étape de réglage de région de valeur de référence (S38) afin d'acquérir des informations de niveau de saturation en oxygène de valeur de référence ;

une étape de calcul d'informations de niveau de saturation en oxygène de valeur relative (S44) pour calculer des informations de niveau de saturation en oxygène de valeur relative dans la région de vaisseau sanguin à partir d'une différence entre les informations de niveau de saturation en oxygène et les informations de niveau de saturation en oxygène de valeur de référence calculées lors de l'étape de calcul d'informations de niveau de saturation en oxygène de valeur de référence ;

une étape de production d'image relative pour produire des données d'image de niveau de saturation en oxygène de valeur relative, en obtenant des informations de niveau de saturation en oxygène de valeur relative à partir d'une différence entre les informations de niveau de saturation en oxygène de valeur absolue et les informations de niveau de saturation en oxygène de valeur de référence, et

une étape d'affichage d'image (S52) pour afficher l'image de niveau de saturation en oxygène de valeur relative produite lors de l'étape de production d'image de valeur relative.

FIG.1

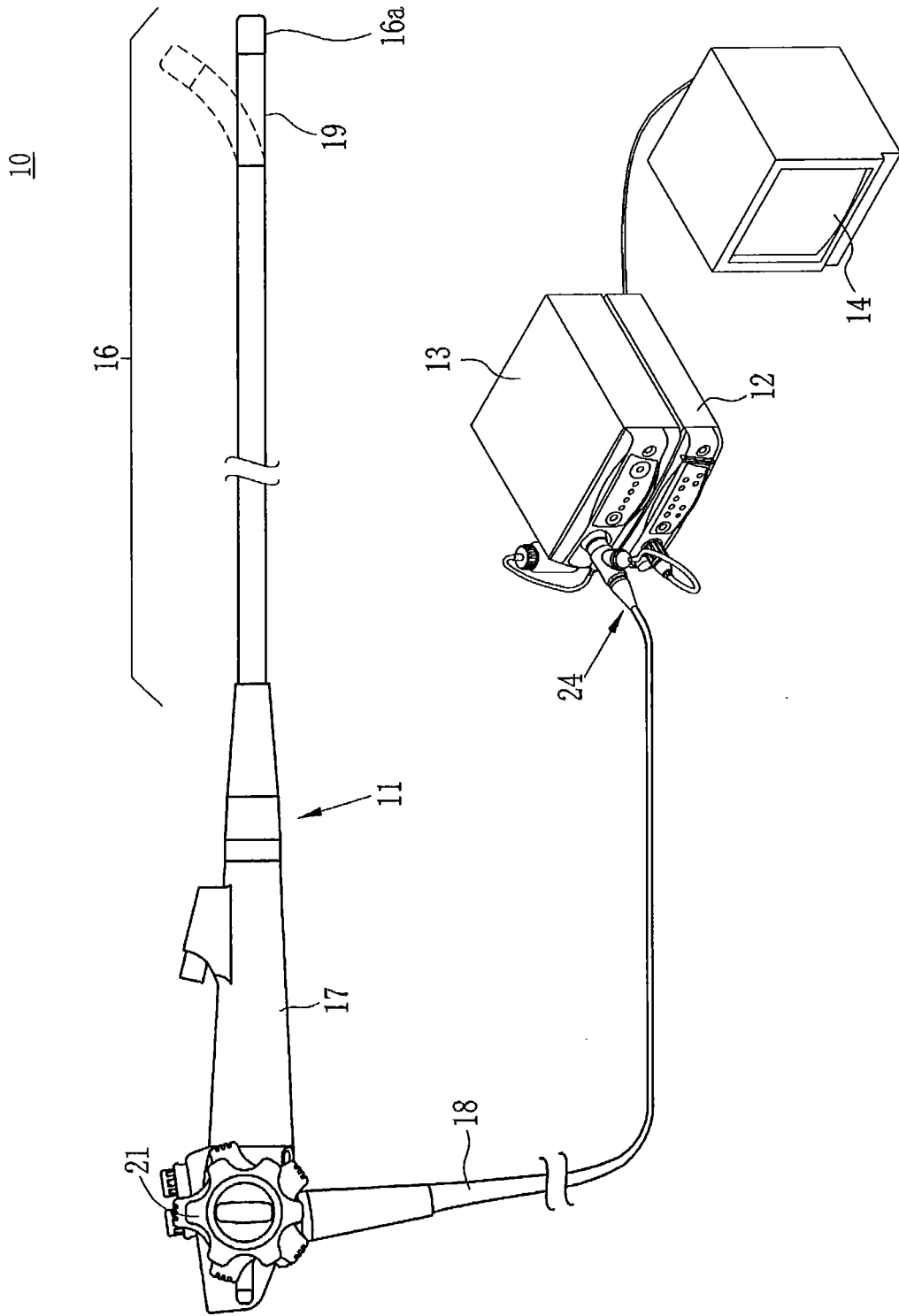

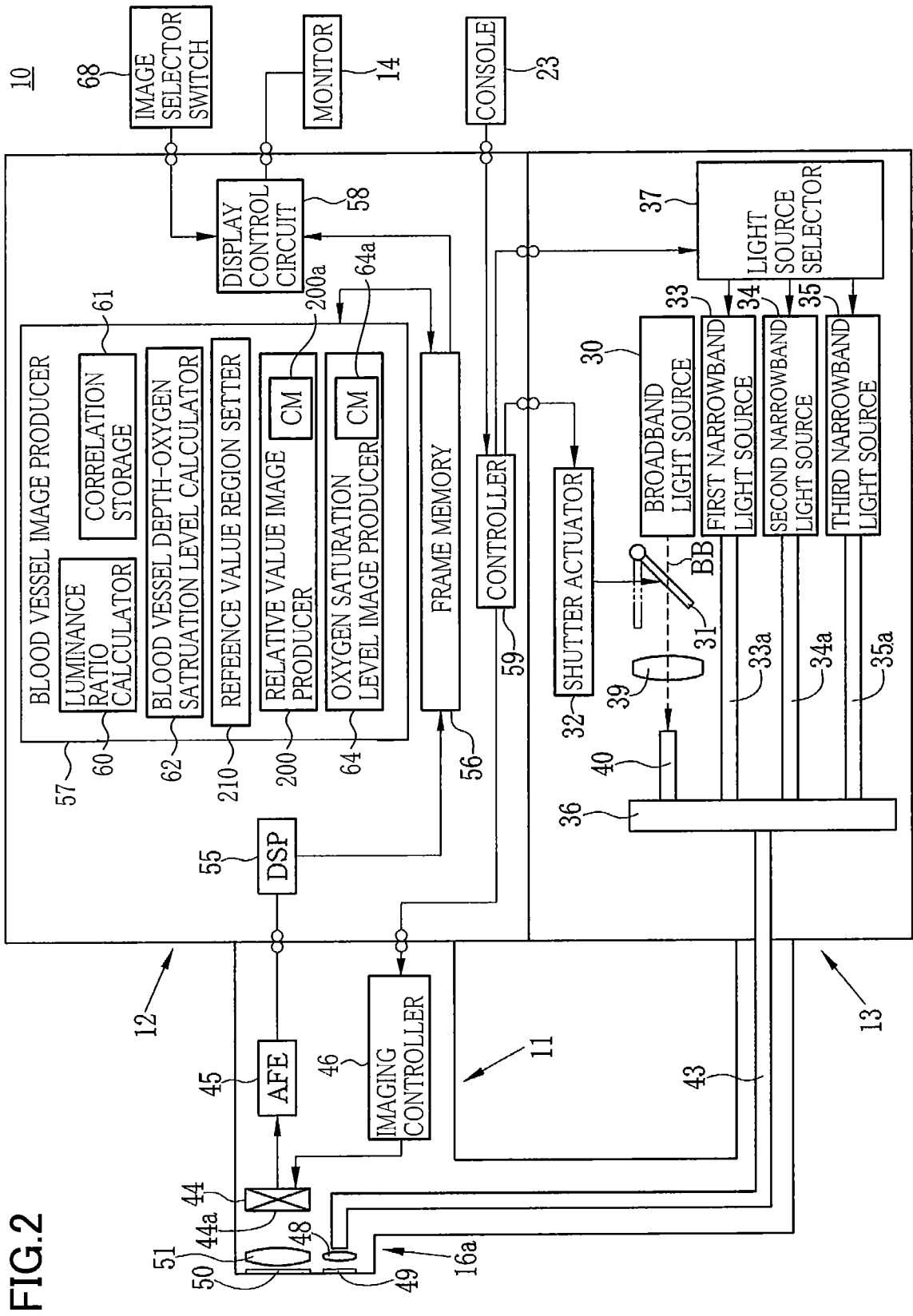

FIG.3

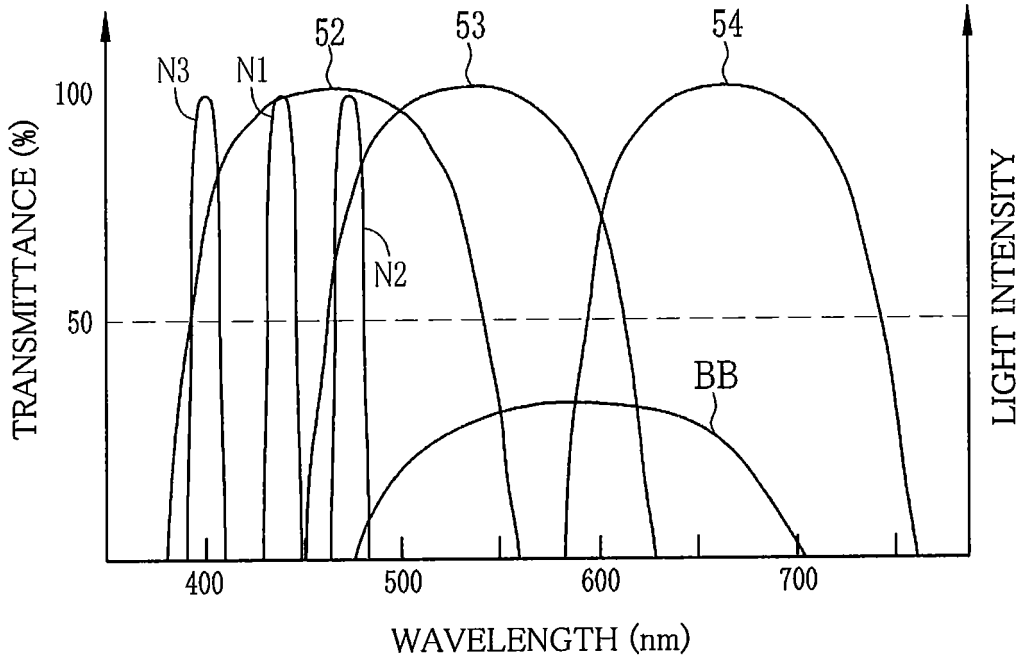

FIG.4A

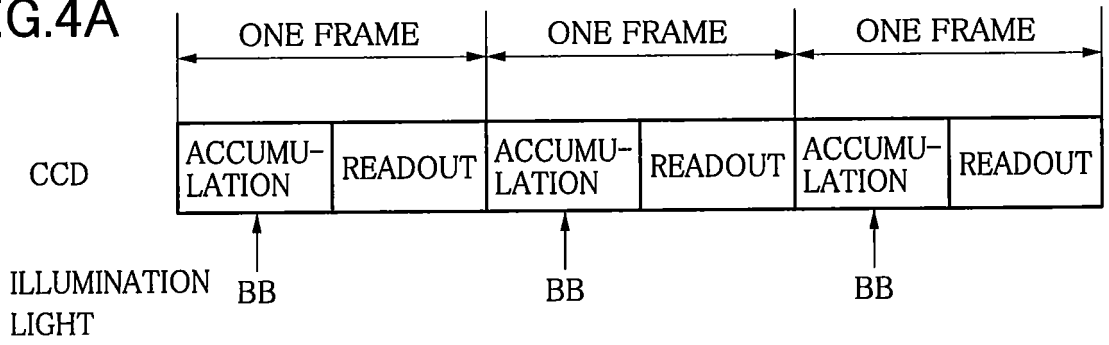

FIG.4B

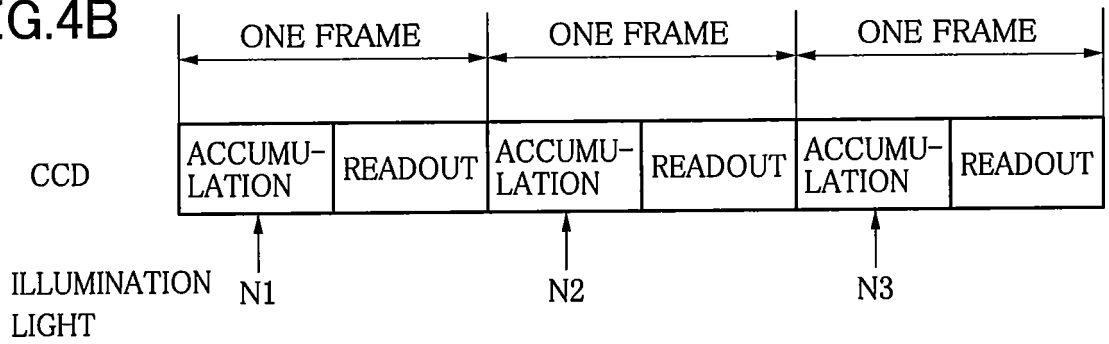

FIG.5

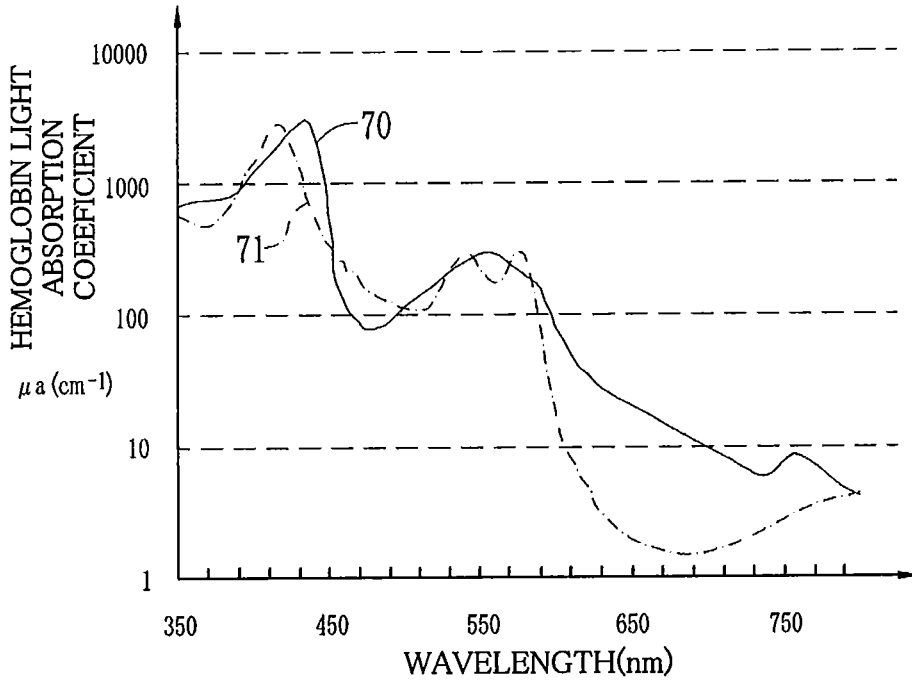

FIG.6

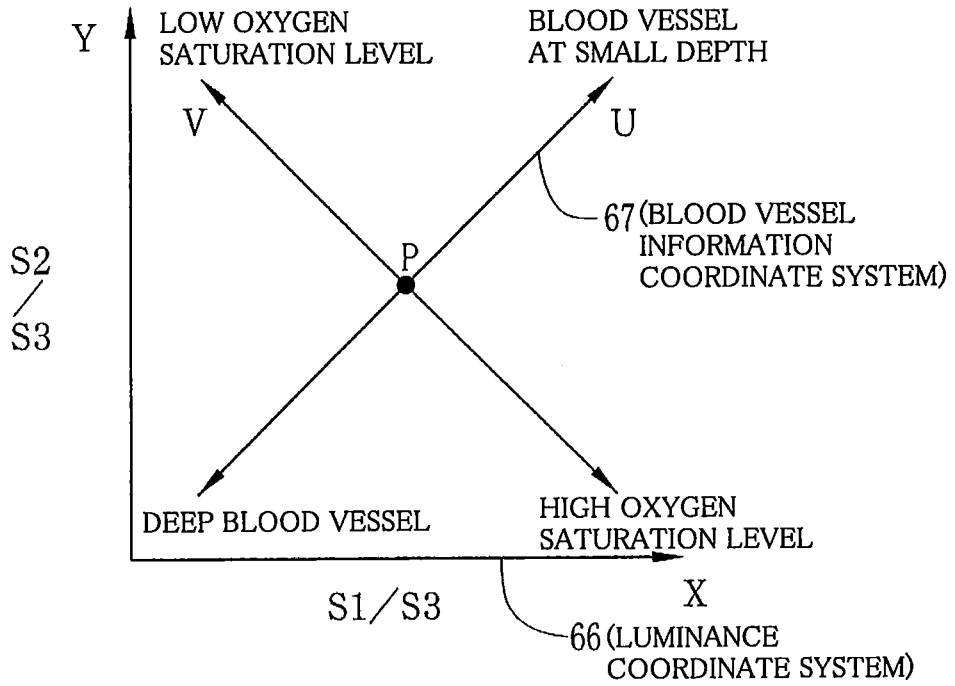

FIG.7A

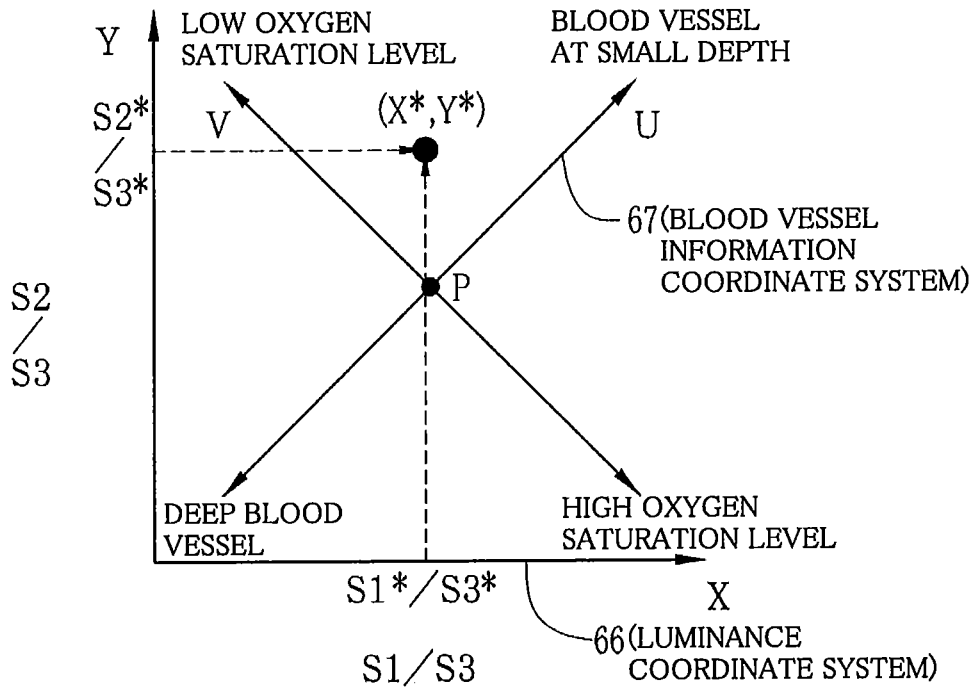

FIG.7B

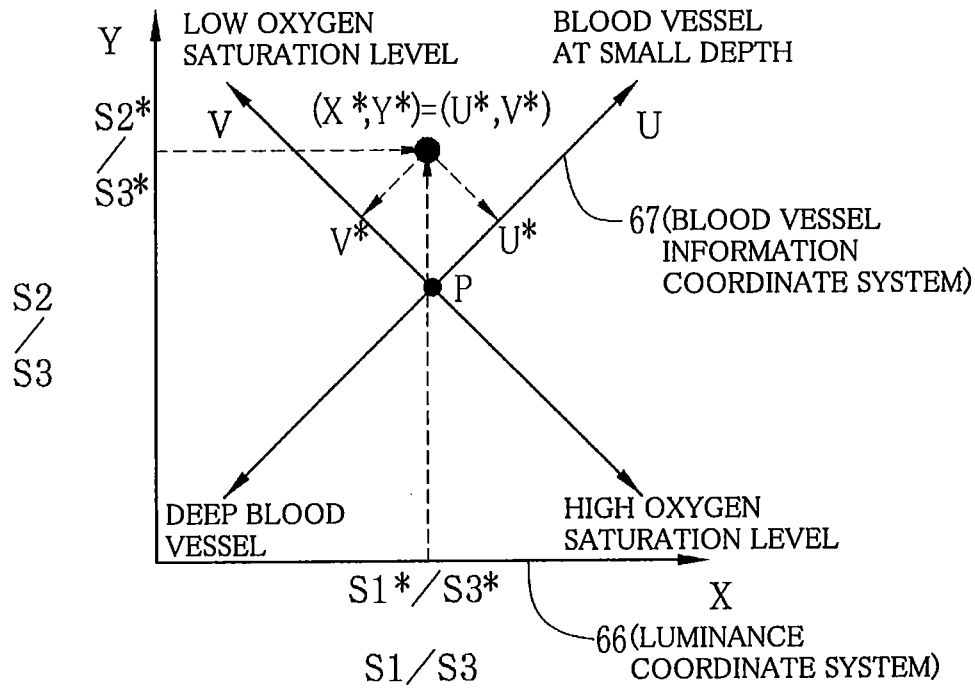

FIG.8

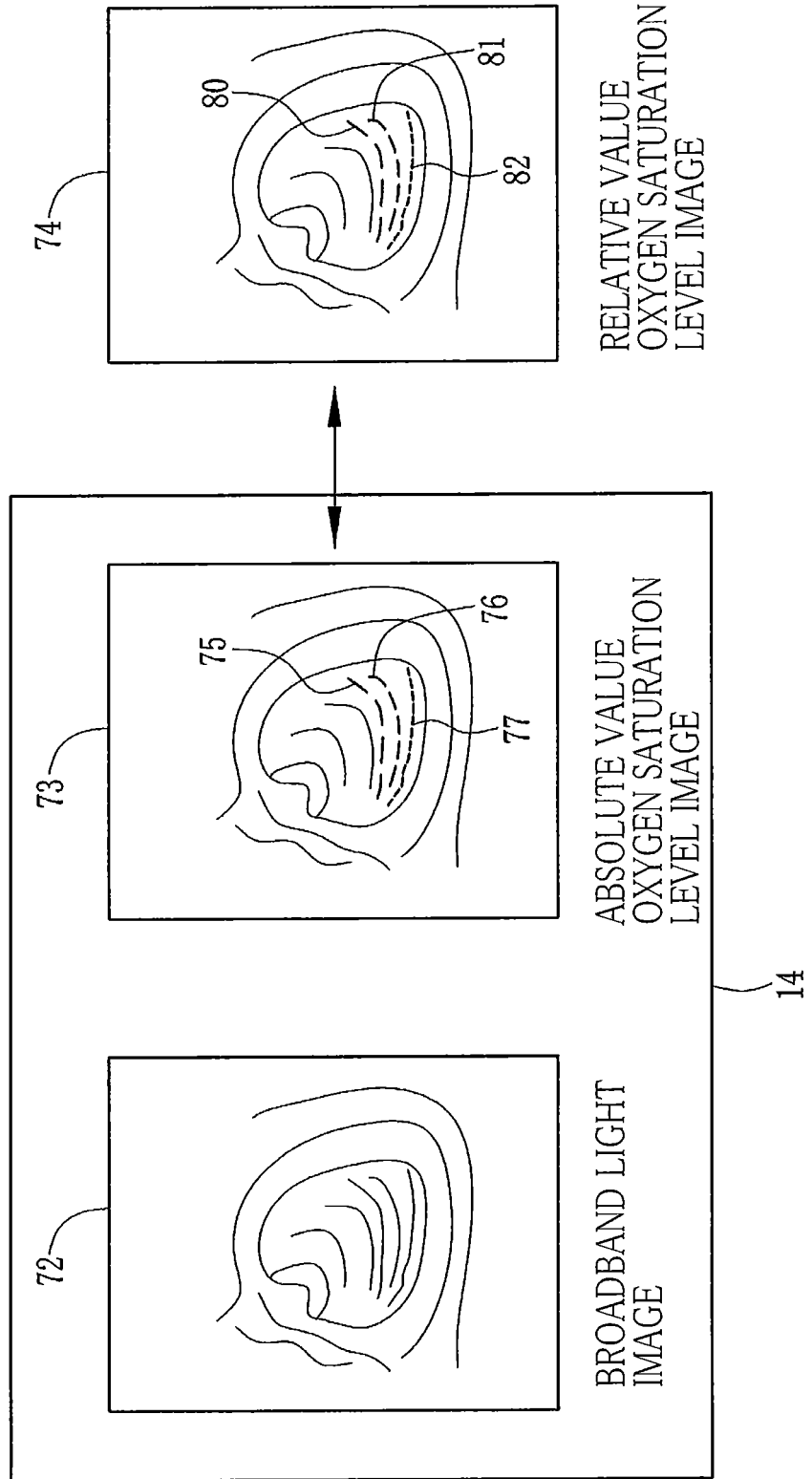

FIG. 9

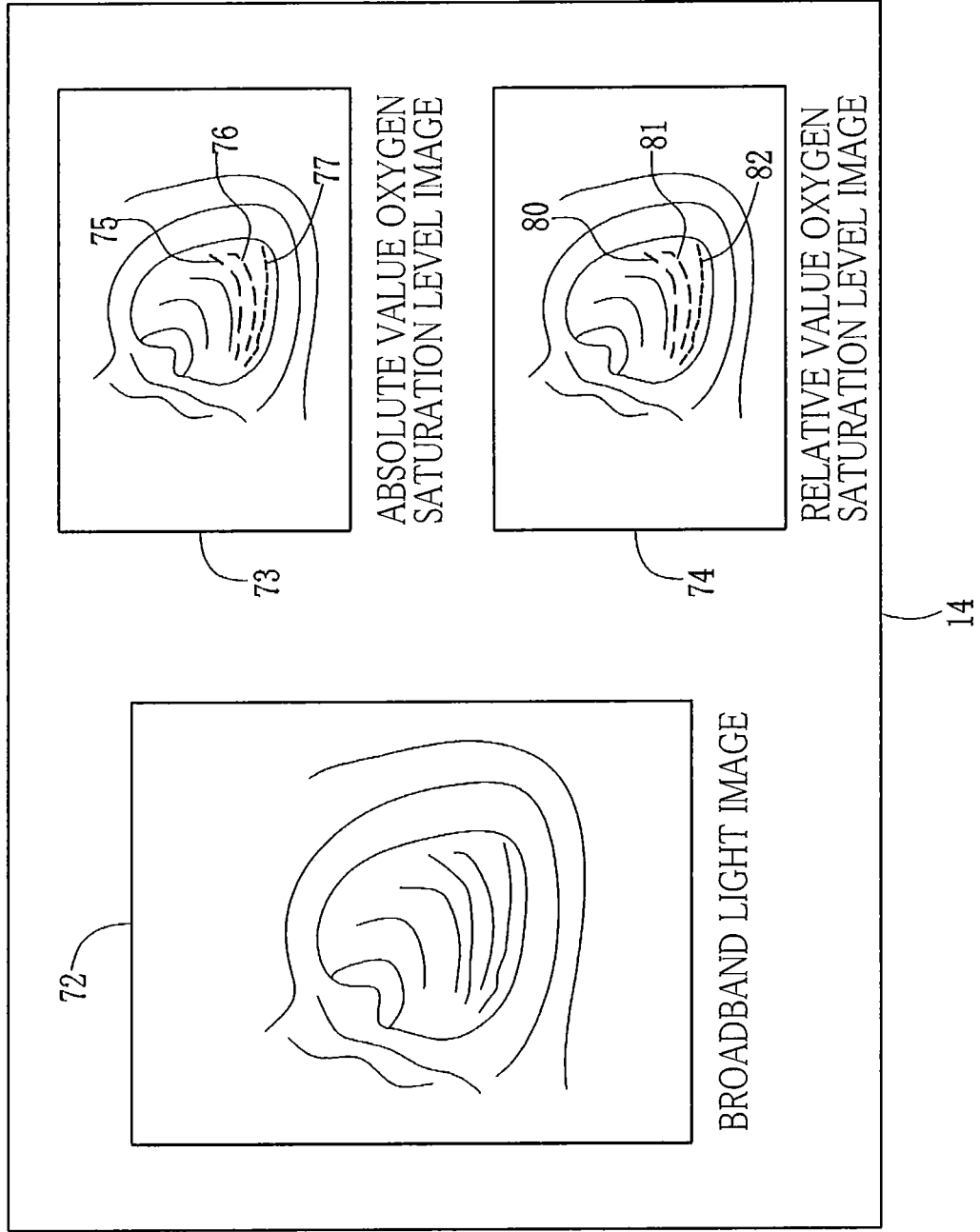

FIG.10

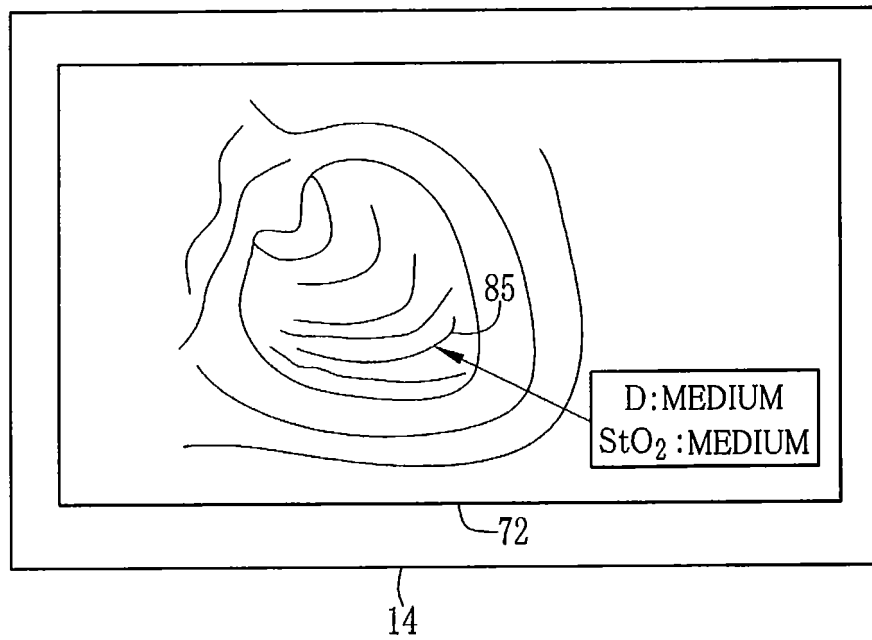

FIG.11

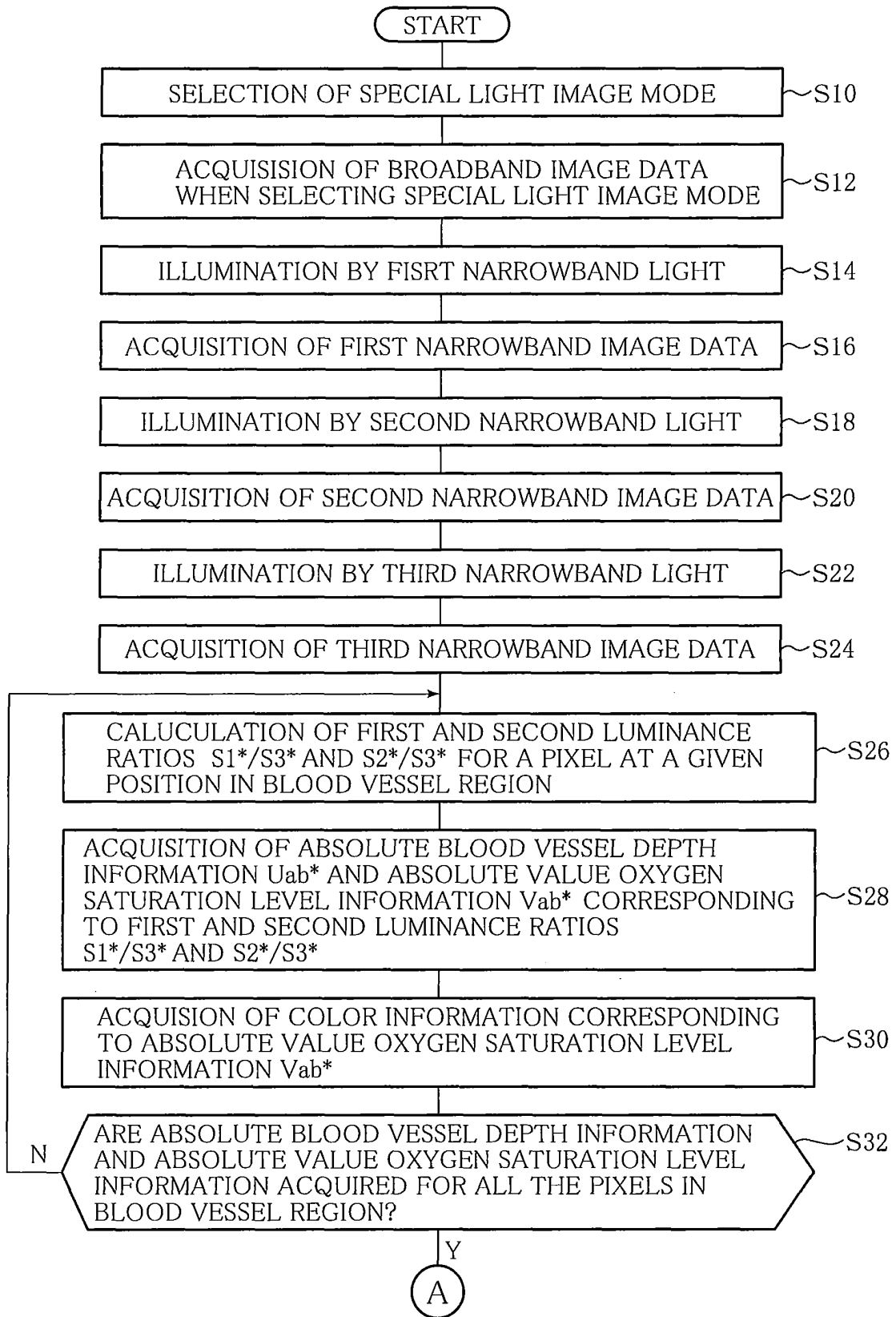

FIG.12

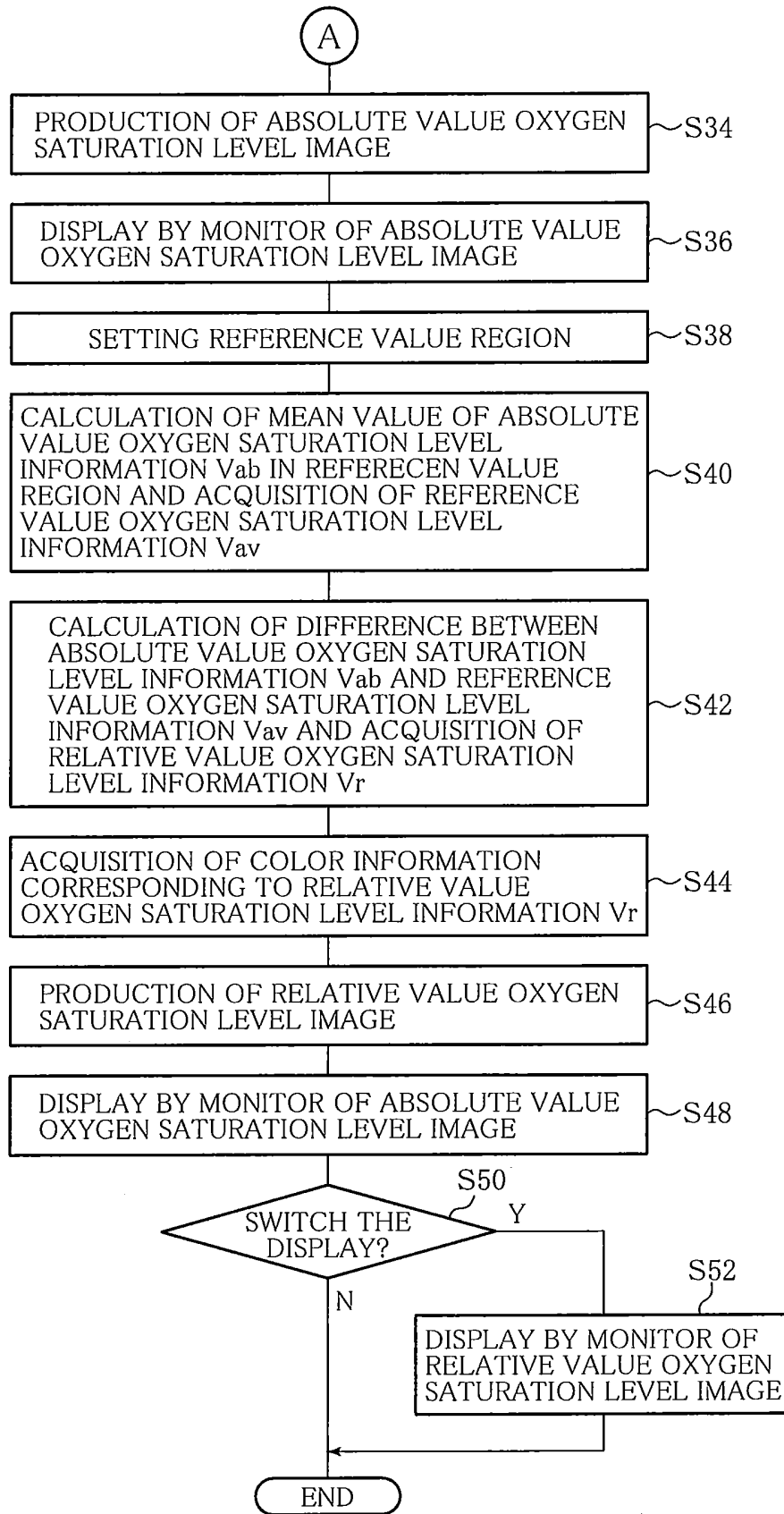

FIG.13

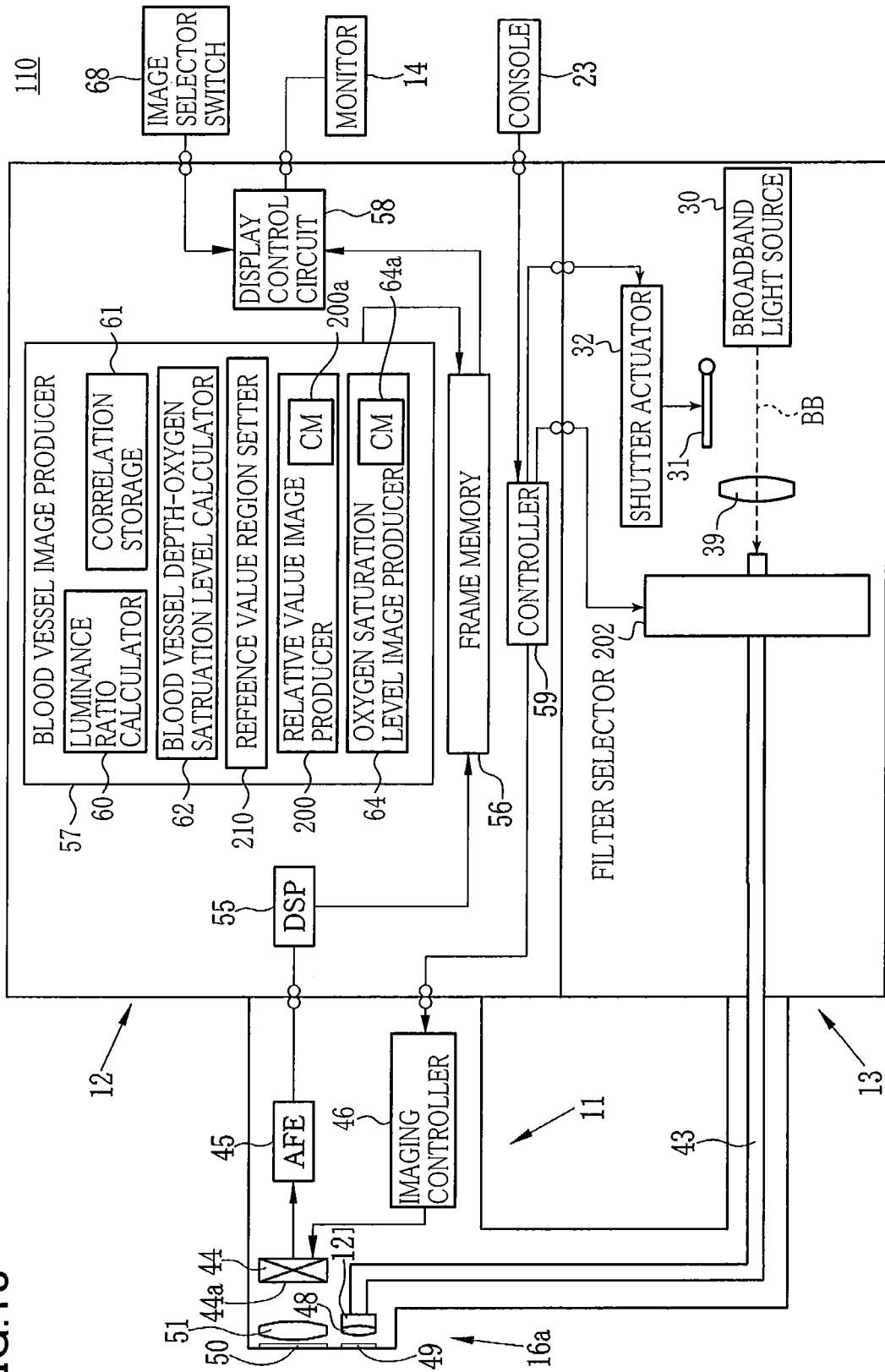

FIG.14

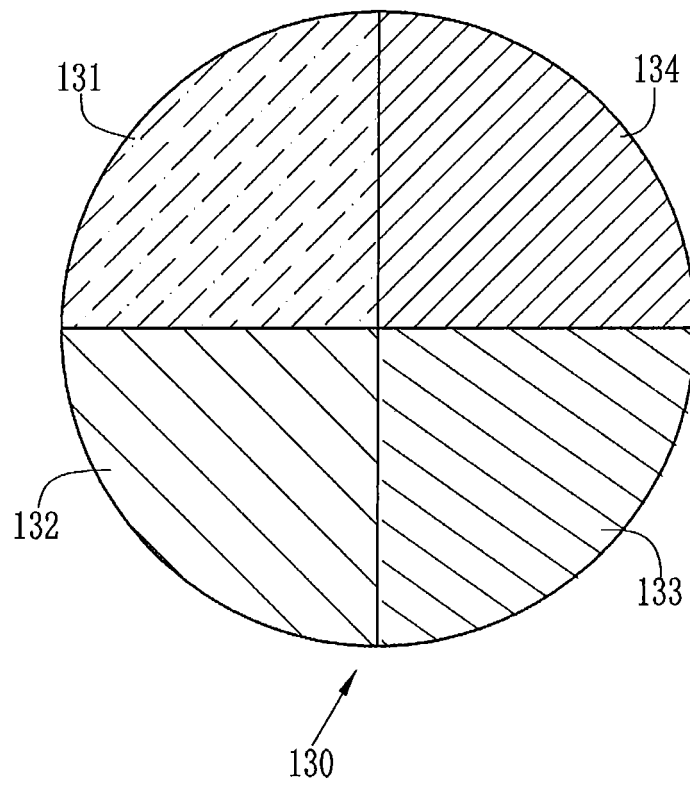
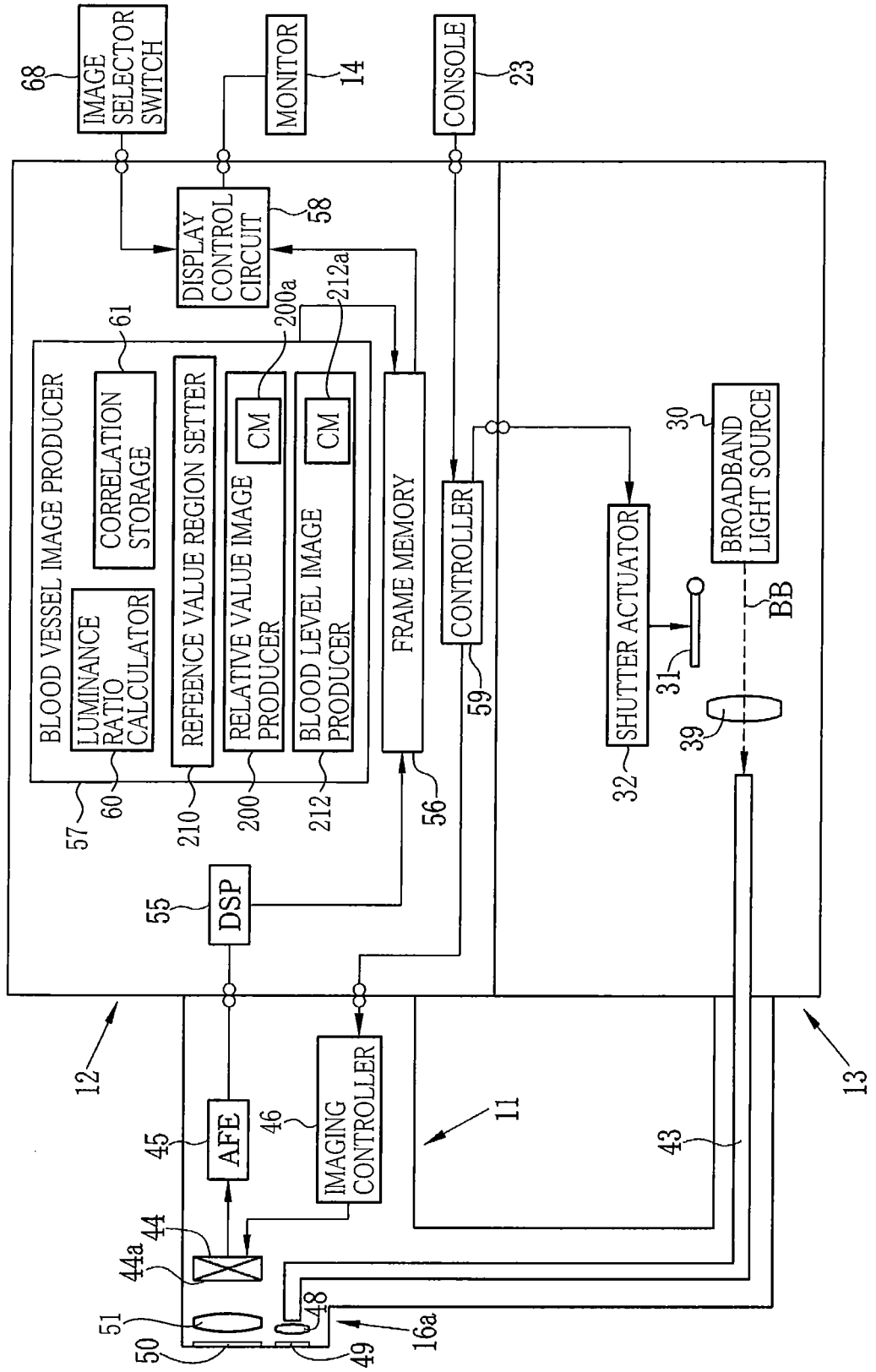

FIG. 15

120



REFERENCES CITED IN THE DESCRIPTION

This list of references cited by the applicant is for the reader's convenience only. It does not form part of the European patent document. Even though great care has been taken in compiling the references, errors or omissions cannot be excluded and the EPO disclaims all liability in this regard.

Patent documents cited in the description

- JP 2001037718 A [0004] [0009]
- JP 2648494 B [0005] [0009]
- US 2009147096 A [0006]
- US 20070135715 A [0007]
- US 20040064016 A [0008]

专利名称(译)	电子内窥镜系统和获取血管信息的方法		
公开(公告)号	EP2366327B1	公开(公告)日	2019-04-17
申请号	EP2011152565	申请日	2011-01-28
[标]申请(专利权)人(译)	富士胶片株式会社		
申请(专利权)人(译)	富士胶片株式会社		
当前申请(专利权)人(译)	富士胶片株式会社		
[标]发明人	SAITO TAKAAKI		
发明人	SAITO, TAKAAKI		
IPC分类号	A61B1/07 A61B1/05 A61B1/04 A61B5/1455 G06T5/00 A61B5/00		
CPC分类号	A61B5/1459 A61B1/00009 A61B1/00045 A61B1/0005 A61B1/063 A61B1/0638 A61B1/0646 A61B5/0084 A61B5/14551 G06T7/0012 G06T2207/10068 G06T2207/30101		
优先权	2010064049 2010-03-19 JP		
其他公开文献	EP2366327A2 EP2366327A3 EP2366327B8		
外部链接	Espacenet		

摘要(译)

该系统包括照明单元，电子内窥镜，用于从成像信号输出具有不同波长带的第一图像数据的单元，用于从第一图像数据产生血管信息的单元，用于在图像中设置给定区域的单元作为参考值区域，用于基于参考值区域内的区域的第二图像数据计算血管信息的参考值的单元，用于根据血管信息和血管信息之间的差异计算相对值血管信息的单元参考值血管信息，用于根据相对值血管信息产生模拟颜色相对值血管信息图像的单元，以及用于显示相对值血管信息图像的监视器。

