

(19)



(11)

EP 1 921 991 B1

(12)

EUROPEAN PATENT SPECIFICATION

(45) Date of publication and mention of the grant of the patent:
09.10.2013 Bulletin 2013/41

(51) Int Cl.:
A61B 5/1455 ^(2006.01) **A61B 5/00** ^(2006.01)
A61B 5/024 ^(2006.01) **G01N 21/31** ^(2006.01)

(21) Application number: **06802210.2**

(86) International application number:
PCT/US2006/033008

(22) Date of filing: **24.08.2006**

(87) International publication number:
WO 2007/030331 (15.03.2007 Gazette 2007/11)

(54) OPTICAL PROBE FOR OPTICAL IMAGING SYSTEM

OPTISCHE SONDE FÜR EIN OPTISCHES BILDGEBUNGSSYSTEM

SONDE OPTIQUE POUR SYSTEME D'IMAGERIE OPTIQUE

(84) Designated Contracting States:
DE ES FR GB LT SI

- **MAO, Jian-Min**
Fremont, California 94536 (US)
- **LIN, Qiong**
Fremont, California 94539 (US)

(30) Priority: **08.09.2005 US 162376**

(43) Date of publication of application:
21.05.2008 Bulletin 2008/21

(74) Representative: **O'Connell, David Christopher**
Haseltine Lake LLP
Redcliff Quay
120 Redcliff Street
Bristol BS1 6HU (GB)

(60) Divisional application:
11178840.2 / 2 389 862

(73) Proprietor: **Vioptix, Inc.**
Fremont CA 94538 (US)

(56) References cited:

EP-A- 0 663 591	EP-A- 1 518 494
WO-A-00/28887	WO-A-96/41566
WO-A-98/22018	US-A- 5 088 493
US-A1- 2003 144 583	US-A1- 2004 111 016

(72) Inventors:

- **LASH, Robert**
Redwood City, California 94026 (US)

EP 1 921 991 B1

Note: Within nine months of the publication of the mention of the grant of the European patent in the European Patent Bulletin, any person may give notice to the European Patent Office of opposition to that patent, in accordance with the Implementing Regulations. Notice of opposition shall not be deemed to have been filed until the opposition fee has been paid. (Art. 99(1) European Patent Convention).

Description

BACKGROUND OF THE INVENTION

1. Field of Invention

[0001] The present invention relates generally to optical imaging systems that monitor oxygen levels in tissue. More specifically, the present invention relates to optical probes that include sources and detectors that are not symmetrically arranged on sensor heads of the optical probes.

2. Description of the Related Art

[0002] Near- infrared spectroscopy has been used for non- invasive measurement of various physiological properties in animal and human subjects. The basic principle underlying the near- infrared spectroscopy is that physiological tissues include various highly- scattering chromophores to the near- infrared waves with relatively low absorption. Many substances in a medium may interact or interfere with the near- infrared light waves propagating therethrough. Human tissues, for example, include numerous chromophores such as oxygenated hemoglobin, deoxygenated hemoglobin, water, lipid, and cytochrome, where the hemoglobins are the dominant chromophores in the spectrum range of approximately 700 nm to approximately 900 nm. Accordingly, the near- infrared spectroscope has been applied to measure oxygen levels in the physiological medium such as tissue hemoglobin oxygen saturation and total hemoglobin concentrations.

[0003] Various techniques have been developed for the near- infrared spectroscopy, e.g., time- resolved spectroscopy (TRS), phase modulation spectroscopy (PMS), and continuous wave spectroscopy (CWS). In a homogeneous and semi- infinite model, both TRS and PMS have been used to obtain spectra of an absorption coefficient and reduced scattering coefficient of the physiological medium by solving a photon diffusion equation, and to calculate concentrations of oxygenated and deoxygenated hemoglobins as well as tissue oxygen saturation. CWS has generally been designed to solve a modified Beer- Lambert equation and to measure changes in the concentrations of oxygenated and deoxygenated hemoglobins.

[0004] Despite their capability of providing the hemoglobin concentrations as well as the oxygen saturation, one major drawback of TRS and PMS is that the equipment is bulky and expensive. CWS may be manufactured at a lower cost but limited in its utility because it cannot compute the oxygen saturation from the changes in the concentrations of oxygenated and deoxygenated hemoglobins.

[0005] Optical Diffusion Imaging and Spectroscopy (ODIS) allows tissue to be characterized based on measurements of photon scattering and absorption. In tissue

such as human tissue, near infrared light is highly scattered and minimally absorbed. Optical diffusion imaging is achieved by sending optical signals into tissue and measuring the corresponding diffuse reflectance or transmittance on the tissue surface.

[0006] Scattering is caused by the heterogeneous structure of a tissue and, therefore, is an indicator of the density of a cell and the nuclear size of the cell. Absorption is caused by interaction with chromophores. ODIS emits light into tissue through a sensor. The position of the light source which emits the light and a detector which detects the light allows a depth of measurement to be determined. A ratio of oxyhemoglobin and deoxyhemoglobin may be used to allow for substantially real- time measurement of oxygen, e.g., oxygen saturation levels.

[0007] Within ODIS systems, sensors which come into contact with tissue surfaces generally have optical fibers arranged thereon in a substantially symmetric layout. That is, optical fibers that are coupled to light sources are arranged in a substantially symmetric orientation relative to optical fibers that are coupled to light detectors. While a symmetric orientation is effective in allowing for oxygen saturation levels to be measured, the manufacture of such sensor is often difficult, as the exact placement of the optical fibers within the sensor is crucial. Further, when the anatomy of tissue or underlying structure is not substantially symmetric, the use of a sensor with a symmetric orientation may not allow for accurate measurements to be readily made.

[0008] WO0028887 discloses an instrument for local and non- invasive measurement of oxygen metabolism in tissue comprising one or more light sources with the light transmitted by optic fibers to the tissue and one or more detectors to receive the scattered reflected light from the tissue through optic fibers. Symmetric source detector arrangements are used. US2003144583 discloses a chromosphere information providing system, for determining absolute value of oxygenation and/or deoxygenation and their ratios, with symmetric source detector arrangements.

[0009] Therefore, what is needed is a sensor that is relatively easy to manufacture, and is arranged to be used on tissue which may not have a symmetric anatomy. That is, what is desired is a sensor with a layout of optical fibers for light sources and optical fibers for detectors that facilitates use with tissue having substantially any anatomy.

SUMMARY OF THE INVENTION

[0010] The present invention as defined by the appended claims, relates to a probe with a sensor that supports source fibers and detector fibers such that the source fibers have a substantially non- symmetric arrangement relative to the detector fibers. According to one aspect of the present invention, a sensor arrangement that is suitable for use in an optical imaging system and is arranged to contact a body such as tissue includes

a first source structure, a second source structure, and a detector arrangement. The first source structure provides a first beam of light and the second source structure provides a second beam of light. The detector arrangement includes detector structures that each have a centerpoint, and receives the first beam of light and the second beam of light after the first beam of light and the second beam of light are reflected off of the body. The detector arrangement is arranged to define a first axis that passes through the centerpoint of each detector structure, and a distance from a centerpoint of the first source structure to the first axis is not equal to a distance from a centerpoint of the second source structure to the first axis.

[0011] In one embodiment not forming part of the claimed invention, a difference between the distance from the centerpoint of the first source structure to the first axis and the distance from the centerpoint of the second source structure is at least approximately 0.03 millimeters. In such an embodiment, the distance from the centerpoint of the first source structure to the first axis may be approximately 0.020 millimeters and the distance from the centerpoint of the second source structure to the first axis may be approximately 0.24 millimeters.

[0012] A probe with a sensor or a sensor head that has source structures in a non-symmetric orientation with respect to detector structures enables the sensor head to be utilized to monitor tissue with an underlying anatomy that is not substantially symmetric. The lack of symmetry also effectively loosens manufacturing tolerances associated with the manufacture of such sensor. Any attenuation associated with the offset orientation of optical fibers that are coupled to light sources is typically compensated for through the use of software code devices executing with respect to an optical imaging system. Hence, the amount of compensation applied may be relatively easily varied as needed to accommodate inaccuracies in the positioning of optical fibers with respect to the sensor.

[0013] According to another aspect of the present invention, a sensor arrangement that is suitable for use in an optical imaging system includes a first source structure that is arranged to provide a first beam of light and a second source structure that is arranged to provide a second beam of light. The sensor arrangement also includes a detector arrangement that has a first detector structure with a first centerpoint and a second detector structure with a second centerpoint. The detector arrangement is arranged to receive the first beam of light and the second beam of light after the first beam of light and the second beam of light are reflected off of a body. An orientation of the first source structure with respect to the detector arrangement is not symmetric relative to an orientation of the second source structure with respect to the detector arrangement.

[0014] According to yet another aspect not forming part of the claimed invention, a method for taking an oxygen saturation measurement of tissue using an optical sys-

tem that utilizes a probe with a sensor head in which a first source structure and a second source structure are offset relative to detector structures involves positioning the sensor head in contact with the tissue and transmitting light into the tissue through the first source structure and the second source structure. The method also involves receiving reflected light from the tissue at the detector structures that includes attenuation characteristics, and processing the reflected light using a plurality of photodetectors. Processing the reflected light using the plurality of photodetectors includes compensating for the attenuation characteristics using an attenuation compensator.

[0015] In accordance with still another aspect not forming part of the claimed invention a probe which may be used as a part of an optical system to monitor oxygen levels in tissue includes a coupling interface that allows the probe to be coupled to light sources and detectors. A sensor head of the probe is arranged to contact the tissue, and supports a first source structure, a second source structure, and a detector arrangement. The first source structure and the second source structure are coupled to the light sources via the coupling interface, while the detector arrangement is coupled to the detectors through the coupling interface. An orientation of the first source structure relative to the detector arrangement is not symmetric with respect to an orientation of the second source structure relative to the detector arrangement.

[0016] In one embodiment, the detector arrangement includes detector structures that each have a centerpoint. In such an embodiment, the detector arrangement receives the first beam of light and the second beam of light after the first beam of light and the second beam of light are reflected off of the tissue. The detector arrangement defines a first axis that passes through the centerpoint of each detector structure of the plurality of detector structures such that a distance from a centerpoint of the first source structure to the first axis is unequal to a distance from a centerpoint of the second source structure to the first axis.

[0017] These and other advantages of the present invention will become apparent upon reading the following detailed descriptions and studying the various figures of the drawings.

BRIEF DESCRIPTION OF THE DRAWINGS

[0018] The invention may best be understood by reference to the following description taken in conjunction with the accompanying drawings in which:

FIG. 1A is a block diagram representation of an optical imaging system with a sensor head which includes sources in an offset arrangement relative to detectors in accordance with an embodiment of the present invention.

FIG. 1B is a block diagram representation of an op-

tical imaging system with a sensor head which includes sources in an offset arrangement relative to detectors, *i.e.*, optical imaging system 100 of FIG. 1A, in accordance with an embodiment of the present invention.

FIG. 2A is a diagrammatic representation of a sensor head with a pair of light sources that are in an offset arrangement relative to a pair of detectors in accordance with an embodiment of the present invention. FIG. 2B is a diagrammatic representation of a sensor head with a pair of light sources that are in an offset arrangement relative to a set of four detectors in accordance with a first embodiment of the present invention.

FIG. 2C is a diagrammatic representation of a sensor head with a pair of light sources that are in an offset arrangement relative to a set of four detectors in accordance with a second embodiment of the present invention.

FIG. 3 is a block diagram representation of light sources and detectors that are associated with a sensor head in accordance with an embodiment of the present invention.

FIG. 4 is a process flow diagram which illustrates one method of utilizing a sensor head with light sources that are in an offset arrangement relative to detectors in accordance with an embodiment of the present invention.

FIG. 5 is a diagrammatic representation of an optical imaging system that includes a console and a decoupleable probe with a sensor head with light sources that are in an offset arrangement relative to detectors in accordance with an embodiment of the present invention.

DETAILED DESCRIPTION OF THE EMBODIMENTS

[0019] A sensor head which is such that optical fibers that are coupled to light sources are arranged in an offset orientation relative to optical fibers that are coupled to detectors allows the sensor head to be utilized in areas in which tissue being monitored is not substantially symmetric. Any attenuation associated with the offset orientation of optical fibers that are coupled to light sources is typically compensated for through software. Such a sensor head is relatively easy to manufacture in that the placement of optical fibers that are coupled to light sources is less rigid, *i.e.*, any slight variation in the placement of the optical fibers may be corrected for using the software that compensates for attenuation. In addition, the use of software to compensate for attenuation associated with the placement of optical fibers on a sensor head essentially enables the sensor head to be used with both symmetric and asymmetric tissue anatomies.

[0020] As will be understood by those skilled in the art, a volume of tissue substantially immediately beneath a sensor head may either be homogeneous or inhomogeneous depending upon the actual anatomical structures

contained within this volume. By way of example, when a sensor head is positioned on skin overlying a thick region of adipose tissue, the distribution of signet cells and capillaries containing oxygenated hemoglobin is generally relatively uniform, *i.e.*, symmetric and homogenous. However, a sensor head may be positioned over a tissue volume in which underlying structure include arteries, veins, bone, tendon, cartilage, fascia, muscle, or pigmented lesions. Such tissue may have asymmetric anatomies that cause light to be reflected or absorbed asymmetrically due, for example, to regions that are either unusually reflective or absorptive. Software that compensates for attenuation may eliminate readings associated with light that reflects off of structures such as bone. Optical fibers that are coupled to sources and are positioned in a sensor head in an offset orientation relative to optical fibers coupled to detectors may facilitate the transmission and reading of light that avoids structures such as bone. Hence, the use of offset source optical fiber orientations facilitate the creation of specialized sensor heads that may be used to measure oxygen saturation in many different parts of a body.

[0021] FIG. 1A is a block diagram representation of an optical imaging system with a sensor head that includes source arrangements arranged in an offset orientation relative to detector arrangements in accordance with an embodiment of the present invention. An optical imaging system 100 includes a unit 104 and a probe 108 that are coupled via a connection interface 112. Connection interface 112 is generally a light-tight interconnection with a laser safety interlock that is arranged to substantially prevent laser light from being emitted through connection interface 112 when probe 108 is not coupled to unit 104. Connection interface 112 typically includes a panel connector (not shown) attached to unit 104 and a cable connector (not shown) attached to probe 108.

[0022] Unit 104 includes a first light source 116 and a second light source 120. First light source 116 and second light source 120, in the described embodiment, are each dual wavelength light sources. In other words, first light source 116 provides two wavelengths of light and second light source 120 provides two wavelengths of light. First light source 116 and second light source 120 may each include a laser diode that provides a light beam or pulse at a lower frequency and a laser diode that provides a light beam or pulse at a higher frequency. By way of example, first light source 116 and second light source 120 may each include a laser diode that produces visible red light of an approximately 690 nanometer (nm) wavelength and a laser diode that produces near infra red light of an approximately 830 nm wavelength. It should be appreciated, however, that the wavelengths of light produced by laser diodes associated with first light source 116 and second light source 120 may vary widely.

[0023] Light emitted by first light source 116 and light emitted by second light source 120 is provided to a beam combiner 124 via optical fibers (not shown). Each laser diode associated with first light source 116 and each

laser diode associated with second light source 120 is provided on a separate optical fiber (not shown). Beam combiner 124 effectively merges the light from the laser diodes of first light source 116 and merges the light from the laser diodes of second light source 120. The merged light is then provided via output fibers (not shown) to connection interface 112. The output fibers are arranged to allow the merged or combined light to be homogenized to ensure that the light is substantially uniformly distributed across the output fibers when the light enters connection interface 112.

[0024] Through connection interface 112, light is provided to a sensor head 128 of probe 108. Within sensor head 128, optical fibers (not shown) provide the merged light associated with first light source 116 and the merged light associated with second light source 120 to a surface of sensor head 128 that is arranged to come into contact with tissue 132. The optical fibers (not shown) are positioned such that they have an offset orientation with respect to optical fibers (not shown) that are associated with photodetectors 136 within unit 104. The orientation of source optical fibers and detector optical fibers will be described below with respect to FIGS. 2A-2C.

[0025] When sensor head 128 causes light to be transmitted into tissue 132, the reflected light is collected by optical detector fibers (not shown) that are coupled to photodetectors 136. In general, at least two photodetectors 136 are included within unit 104 and are configured to be sensitive to the light which is transmitted by first light source 116 and second light source 120. An attenuation compensator 140 within unit 104 is generally arranged to compensate for any attenuation in the reflected light that results from the offset orientation of source optical fibers (not shown) relative to detector optical fibers (not shown). In one embodiment, attenuation compensator 140 effectively provides compensation using a mathematical algorithm that constructs ratios in which attenuation coefficients may be found in both a numerator and a denominator and hence, may be cancelled out. Such ratios may use light intensities as detected by photodetectors 136 in such a way that attenuation factors have little effect on the evaluation of optical properties of tissue 132 beneath sensor head 128. It should be appreciated that attenuation compensator 140 may generally be substantially incorporated into software or firmware that executes an algorithm that determines oxygen saturation levels.

[0026] FIG. 1B is a block diagram representation of optical imaging system 100 of FIG. 1A which shows the path of light emitted by light sources, *i.e.*, first light source 116 and second light source 120 of FIG. 1A, in accordance with an embodiment of the present invention. When first light source 116 emits light at two wavelengths, light of the first wavelength 152a and light of the second wavelength 152b are provided to beam combiner 124 which effectively merges the light into a light stream 152c that is provided to sensor head 128, *e.g.*, through optical source fibers. Similarly, when second light source 120

emits light at two wavelengths, light of the first wavelength 156a and light of the second wavelength 156b are merged into a light stream 156c by beam combiner 124 that is provided to sensor head 128. Light streams 152c, 156c are transmitted into tissue 132 reflect off of tissue 132, through sensor head 128 to photodetectors 136.

[0027] As previously mentioned, optical source fibers are arranged such that at a surface of a sensor head that is arranged to come into contact with tissue, the optical source fibers have an offset orientation relative to optical detector fibers. With reference to FIG. 2A, the orientation of source fibers with respect to detector fibers will be described in accordance with an embodiment of the present invention. A sensor head 200, which may be of substantially any shape or size, is a part of a probe that is a part of an overall system that measures oxygen saturation levels in tissue. Sensor head 200 is arranged to accommodate source arrangements 204a, 204b, and detector arrangements 208a, 208b. For ease of discussion, although source arrangements 204a, 204b are generally fiberoptic cables or optical fibers coupled to light sources and detector arrangements 208a, 208b are generally fiberoptic cables or optical fibers coupled to photodetectors, source arrangements 204a, 204b are referred to herein as sources and detector arrangements 208a, 208b are referred to herein as detectors.

[0028] Sources 204a, 204b are arranged such that they are in an offset arrangement relative to detectors 208a, 208b. That is, source 204a and source 204b are not equidistant to detectors 208a, 208b relative to at least one axis. Detectors 208a, 208b are arranged such that a centerline 214 of detectors 208a, 208b is approximately parallel to an x-axis 212a. Typically, centerline 214 passes through a centerpoint of each detector 208a, 208b. Sources 204a, 204b are arranged such that a centerline 216 of source 204a is parallel to a centerline 218 of source 204b, but is not coincident with centerline 218. Centerline 216 passes through a centerpoint of source 204a and is parallel to x-axis 212a, while centerline 218 passes through a centerpoint of source 204b and is parallel to x-axis 212a.

[0029] A distance y1 between centerline 214 and centerline 216 along a y-axis 212b differs from a distance y2 between centerline 214 and centerline 218. Although distance y2 is shown as being greater than distance y1, it should be appreciated that distance y1 may instead be greater than y2. The difference between distance y2 and distance y1 is generally characteristic of the offset arrangement, or substantially unbalanced arrangement, of sources 204a, 204b relative to detectors 208a, 208b. In other words, there is effectively a lack of symmetry in the placement of sources 204a, 204b.

[0030] In general, more than two detectors may be used in conjunction with a pair of detectors to monitor oxygen saturation in tissue. By way of example, three or four detectors may be used to detect light that is provided by a pair of sources and is reflected off of a tissue surface. It should be appreciated that some of the light may be

reflected from tissue at various depths beneath the tissue surface. That is, light may be reflected off the tissue surface and off of tissue that underlies the surface. The tissue that underlies the surface and allows light to be reflected may be as deep as approximately one centimeter below the surface of the tissue. FIG. 2B is a diagrammatic representation of a sensor head which is arranged to include a pair of sources or, more specifically, source arrangements and four detectors or, more specifically, detector arrangements, in accordance with an embodiment of the present invention. A sensor head 220 includes four detectors 228a-d which are arranged such that centerpoints of detectors 228a-d are substantially aligned along a centerline 234 that is substantially parallel to an x-axis 232a. Sensor head 220 also includes sources 224a, 224b which each include a centerpoint. A centerline 236 that is parallel to x-axis 232a passes through the centerpoint of source 224a, and a centerline 238 that is parallel to x-axis 232a passes through the centerpoint of source 224.

[0031] In the described embodiment, a distance y_1 along a y-axis 232b between centerline 234 and centerline 236 is not equal to a distance y_2 along y-axis 232b between centerline 234 and centerline 238. Distance y_1 may be approximately 0.2 millimeters (mm), as for example approximately 0.197 mm, while distance y_2 may be approximately 0.24 mm, as for example 0.236 mm. It should be appreciated that distance y_1 and distance y_2 may vary widely depending upon any number of factors. The factors include, but are not limited to, the overall size of sources 224a, 224b and detectors 228a-d, the overall size of sensor head 220, and the application for which sensor head 220 is intended. While distance y_2 is shown as being greater than distance y_1 , distance y_1 may instead be greater than distance y_2 . In general, the difference between distance y_2 and distance y_1 is at least approximately 0.3 mm. For example, distance y_2 and distance y_1 may differ by approximately 1.0 mm.

[0032] The positioning of sources 224a, 224b and detectors 228a-d may vary widely. By way of example, for an embodiment in which sources 224a, 224b and detectors 228a-d are each approximately one mm in diameter, centerpoints of sources 224a, 224b may be separated by a distance d_2 that is approximately 0.22 mm relative to x-axis 232a and by a distance y_4 that is approximately 0.04 mm. Detectors 228a-d may be arranged such that centerline 234 is offset from a top edge of sensor head 220 by a distance y_3 that is approximately 0.06 mm, and such that adjacent detectors 228a-d are separated by a distance d_1 that is between approximately 0.06 mm to approximately 0.07 mm. Sensor head 220 may have a width of approximately 0.34 mm along x-axis 232a and a height of approximately 0.49 mm along y-axis 232b when detectors 228a-d and sources 224a, 224b are spaced as described above. However, sensor head 220 generally has dimensions that may vary widely, e.g., dimensions which may vary depending upon the application for which sensor head 220 is intended.

[0033] While a lack of symmetry in the positioning of sensors relative to detectors has been described as being such that distances between sensors and detectors are not equal relative to a y-axis, a lack of symmetry may instead or additionally have a lack of symmetry relative to an x-axis. Referring next to FIG. 2C, a sensor head that includes a pair of sources which are in an offset arrangement relative to a set of four detectors with respect to an x-axis will be described. A sensor head 240 includes four detectors 248a-d, although the number of detectors 248a-d may vary. Detectors 248a-d are arranged such that a centerline 254 is substantially parallel to an x-axis 252a and passes through the centerpoint of each detector 248a-d. A first detector 248a and a last detector 248d, i.e., the detectors which are farthest apart relative to x-axis 252a, are used to define a central bisecting line 262 of detectors 248a-d. Central bisecting line 262 is parallel to a y-axis 252b, and is arranged such that a distance x_3 from the centerpoint of detector 248a to central bisecting line 262 is substantially equal to a distance x_4 from the centerpoint of detector 248d to central bisecting line 262. That is, central bisecting line 262 is arranged to pass through a central midpoint between the centerpoint of detector 248a and the centerpoint of detector 248d such that central bisecting line 262 is substantially perpendicular to centerline 254.

[0034] As shown, a centerpoint of a first source 244a and the centerpoint of first detector 248a are aligned along a centerline 257 that is substantially parallel to a y-axis 252b. Similarly, a centerpoint of a second source 244b and the centerpoint of last detector 248d may be aligned along a centerline 259 that is substantially parallel to y-axis 252b. It should be appreciated, however, that centerline 257 may not necessarily pass through the centerpoint of first detector 248a, and centerline 259 may not necessarily pass through the centerpoint of last detector 248d. That is, centerline 257 is effectively a line that is substantially parallel to y-axis 252b and passes through first source 244a, while centerline 259 is effectively a line that is substantially parallel to y-axis 252b and passes through second source 244b.

[0035] A distance x_1 between centerline 257 and central bisecting line 262 is not equal to a distance x_2 between centerline 259 and central bisecting line 262. In other words, first source 244a and second source 244b are not equidistant from central bisecting line 262. Hence, sources 244a, 244b are positioned in an offset or unbalanced orientation relative to x-axis 252a.

[0036] Sources are typically arranged to emit light of specific wavelengths. As discussed above, light of a lower wavelength emitted by a source may have a wavelength of approximately 690 nm, while light of a higher wavelength emitted by the source may have a wavelength of approximately 830 nm. FIG. 3 is a block diagram representation of light sources and detectors that are associated with a sensor head in accordance with an embodiment of the present invention. A first source may include a laser diode 302a that produces light at a wave-

length of approximately 690 nm as well as a laser diode 302b that produces light at a wavelength of approximately 830 nm. Similarly, a second source may include a laser diode 306a that produces light at a wavelength of approximately 690 nm as well as a laser diode 306b that produces light at a wavelength of approximately 830 nm.

[0037] A beam combiner 310 is arranged to enable light emitted by laser diodes 302a, 302b to be merged onto an optical fiber 312 that is provided to a sensor head 322. Beam combiner 310 is also arranged to enable light emitted by laser diodes 306a, 306b to be merged onto an optical fiber 316 that is provided to sensor head 322. Light transmitted by fibers 312, 316 through a tissue or other surface is reflected, and the reflected light is effectively captured on optical fibers 324 which provide the reflected light to photodetectors 318. Photodetectors 318 are arranged to be sensitive to light with wavelengths of approximately 690 nm and approximately 830 nm, and typically have a relatively high gain.

[0038] With reference to FIG. 4, one method of monitoring oxygen saturation in tissue using an oximeter with a sensor head in which sources are in an offset orientation relative to detectors will be described in accordance with an embodiment of the present invention not forming part of the claimed invention. A process 400 of using an oximeter begins at step 404 in which a probe, *i.e.*, a probe that includes a sensor head in which sources are positioned in an offset orientation relative to detectors, is applied against tissue. Once the sensor head is positioned in contact with tissue, a first source S1 associated with the probe sends a lower wavelength pulse of light into the tissue in step 408. The first source S1 may include a laser diode that produces an approximately 690 nm wavelength of visible red light, as discussed above, although the lower wavelength of light produced by the first source S1 may vary. In general, first source S1 is a source arrangement that produces light at two wavelengths. Hence, first source S1 may include two substantially separate laser diodes that produce light at two wavelengths.

[0039] In step 412, a detector arrangement associated with the probe detects the approximately 690 nm light. As discussed above, when the approximately 690 nm light is transmitted into the tissue, the approximately 690 nm light is reflected into the detector arrangement such that the detectors, *e.g.*, the photodetectors, included in the detector arrangement collect the reflected light. A second source S2 then sends a lower wavelength pulse of light in step 416 which, in the described embodiment, is an approximately 690 nm pulse of light. The detector arrangement detects and collects the approximately 690 nm reflected light in step 420.

[0040] Once the lower wavelength light is transmitted by both the first source S1 and the second source S2, the first source S1 sends a higher wavelength pulse of light into the tissue in step 424. The higher wavelength pulse of light may be an approximately 830 nm near infrared light produced by a laser diode included in first

source S1. After the approximately 830 nm pulse of light is transmitted into the tissue and reflected, then process flow moves to step 428 in which detector arrangement detects the reflected light.

[0041] The second source S2 sends a higher wavelength pulse of light, *e.g.*, light with an approximately 830 nm wavelength, in step 432 that is then reflected off of the tissue and reflected into the detector arrangement in step 436. Once the detector arrangement has received reflected light from both sensors at both the lower wavelength and the higher wavelength, the data acquisition arrangement of the oximeter processes information associated with the received reflected light in step 440. Processing the received reflected light may include executing software or firmware that accounts for or otherwise compensates for attenuation associated with the reflected light in order to determine an oxygen level associated with the tissue. Once the data acquisition arrangement process the information, the process of monitoring an oxygen saturation level of tissue is completed. It should be understood, however, the steps of FIG. 4 may be repeated to allow for the substantially continuous monitoring of an oxygen saturation level.

[0042] An oximeter which utilizes a probe with a sensor head of the present invention may include a portable console unit to which the probe may be coupled. As shown in FIG. 5, a console 500 may include a screen 504 that is arranged to display the oxygen saturation level of tissue that is being monitored. Screen 504, which may be a touchscreen, may also be arranged to indicate when a probe 520 is in use and to provide warnings to a user that indicate when a monitored oxygen saturation level is potentially problematic.

[0043] Console 500 includes a panel connector 508 to which a connector 528 of probe 520 may be connected to allow a sensor head 530 of probe 520 to be used to monitor oxygen saturation levels. Fiberoptic cables (not shown) which are used to allow light to pass between connector 528 and sensor head 530 of probe 520 are substantially encased in a cable jacket 534. Console 500 and probe 520 may be a part of the ODISsey Tissue Oximeter available commercially from ViOptix, Inc. of Fremont, California.

[0044] By way of example, the wavelengths emitted by light sources have been described as being approximately 690 nm and approximately 830 nm. However, substantially any wavelengths may be emitted by the light sources.

[0045] The probe on which a sensor head is mounted may have a variety of different configurations. For example, the probe may include a handpiece which facilitates spot measurements of tissue. Additionally, the configuration of a sensor head may also vary depending upon the particular application for which the sensor head is to be used.

[0046] A probe, *e.g.*, a fiberoptic probe, on which a sensor head is mounted uses fiberoptic cable to carry an optical signal to an from tissue. The fiberoptic cable may

be of any length, and may contain one dual wavelength source fibers for each source and one detector fiber for each detector. The fiberoptic cable may be approximately three meters long, and the source and detector fibers may each have diameters of approximately one mm.

[0047] A centerpoint of a source optical fiber and a centerpoint of a detector optical fiber have generally been described as being centerpoints of fibers that are substantially circular in orientation. It should be appreciated that in some instances, when a fiber is not substantially circular in orientation, the centerpoint may be an approximate centerpoint of the fiber.

Claims

1. A device comprising a sensor arrangement the sensor arrangement being suitable for use in an optical imaging system (100), the sensor arrangement being arranged to contact a body, the sensor arrangement comprising:

a first source structure (204a) comprising a first optical fiber, the first source structure being arranged to provide a first beam of light;

a second source structure (204b) comprising a second optical fiber, the second source structure being arranged to provide a second beam of light; and

a detector arrangement, the detector arrangement including a plurality of detector structures (208a, 208b) comprising optical fibers that each have a centerpoint, the detector arrangement being arranged to receive the first beam of light and the second beam of light after the first beam of light and the second beam of light are reflected off of at least the body,

wherein the detector arrangement is arranged to define a first axis (214) that passes through the centerpoint of each detector structure (208a, 208b) of the plurality of detector structures, a distance from a centerline (216) that passes through a centerpoint of the first source structure (204a) to the first axis (214) defines a first line segment, a distance from a centerline (218) that passes through a centerpoint of the second source structure (204b) to the first axis (214) defines a second line segment, which is parallel to the first line segment, wherein each of the centerlines and the first axis are approximately parallel to an x-axis (212a) and wherein the centerline (216) of the first source structure (204a) is parallel to, but not coincident with, the centerline (218) of the second source structure (204b) and the lengths of the first and second line segments along a y-axis (212b) are not equal, and wherein the first source structure is adapted to emit a first wavelength of light at a first time, the second

source structure is adapted to emit the first wavelength of light at a second time, the first source structure can emit a second wavelength of light, different from the first wavelength of light, at a third time, and the second source structure can emit the second wavelength of light at a fourth time.

2. The sensor arrangement of claim 1 wherein the sensor arrangement is part of a probe and wherein the optical imaging system is an oximeter.

3. The device of claim 1 further comprising:

a beam combiner (124), coupling each of the first optical fiber and the second optical fiber to two different light sources having different wavelengths.

4. The device of claim 1 wherein the first wavelength of light comprises a 690-nanometer wavelength of light and the second wavelength of light comprises an 830-nanometer wavelength of light.

5. The device of claim 1 wherein the plurality of detector structures includes four detector structures (228a, 228b, 228c, 228d).

6. A device comprising a sensor arrangement, the sensor arrangement being suitable for use in an optical imaging system (100), the sensor arrangement being arranged to contact a body, the sensor arrangement comprising:

a first source structure (244a) comprising a first optical fiber, the first source structure being arranged to provide a first beam of light;

a second source structure (244b) comprising a second optical fiber, the second source structure being arranged to provide a second beam of light; and

a detector arrangement, the detector arrangement including a first detector structure (248a) comprising a first detector optical fiber that has a first detector centerpoint and a second detector structure (248d) comprising a second detector optical fiber that has a second detector centerpoint, the detector arrangement being arranged to receive the first beam of light and the second beam of light after the first beam of light and the second beam of light are reflected off of at least the body,

wherein the first and second detector structures are arranged such that a centerline (254) passing through both the first detector centerpoint and the second detector centerpoint is substantially parallel to an x-axis (252a), a bisecting line (262) that is parallel to a y-axis (252b) and per-

pendicular to the centerline (254) passes through a midpoint between the first detector centerpoint and the second detector centerpoint, a distance from a first source centerpoint of the first source structure to the bisecting line (262) is not equal to a distance from a second source centerpoint of the second source structure to the bisecting line (262), and wherein the first source structure is adapted to emit a first wavelength of light at a first time, the second source structure is adapted to emit the first wavelength of light at a second time, the first source structure can emit a second wavelength of light, different from the first wavelength of light, at a third time, and the second source structure can emit the second wavelength of light at a fourth time.

7. The device of claim 6 further comprising:

a beam combiner, coupling each of the first optical fiber and the second optical fiber to two different light sources having different wavelengths.

8. The device of claim 6 wherein the sensor arrangement is part of a probe and wherein the optical imaging system is an oximeter.

Patentansprüche

1. Vorrichtung, umfassend eine Sensoranordnung, wobei die Sensoranordnung für den Gebrauch in einem optischen Abbildungssystem (100) geeignet ist, und die Sensoranordnung dafür ausgelegt ist, dass sie einen Körper berührt, wobei die Sensoranordnung umfasst:

eine erste Quellenstruktur (204a), die einen ersten Lichtleiter enthält, wobei die erste Quellenstruktur dafür ausgelegt ist, einen ersten Lichtstrahl zu liefern;

eine zweite Quellenstruktur (204b), die einen zweiten Lichtleiter enthält, wobei die zweite Quellenstruktur dafür ausgelegt ist, einen zweiten Lichtstrahl zu liefern; und

eine Detektoranordnung, wobei die Detektoranordnung eine Anzahl Detektorstrukturen (208a, 208b) enthält, die Lichtleiter umfassen, die jeweils einen Mittelpunkt haben, wobei die Detektoranordnung dafür ausgelegt ist, dass sie den ersten Lichtstrahl empfängt und den zweiten Lichtstrahl, nachdem der erste Lichtstrahl und der zweite Lichtstrahl zumindest an dem Körper reflektiert wurden,

wobei die Detektoranordnung dafür ausgelegt ist, eine erste Achse (214) zu definieren, die

durch den Mittelpunkt einer jeden Detektorstruktur (208a, 208b) der Anzahl Detektorstrukturen verläuft, und eine Entfernung von einer Mittellinie (216), die durch einen Mittelpunkt der ersten Quellenstruktur (204a) zu der ersten Achse (214) verläuft, ein erstes Liniensegment definiert, und eine Entfernung von einer Mittellinie (218), die durch einen Mittelpunkt der zweiten Quellenstruktur (204b) zu der ersten Achse (214) verläuft, ein zweites Liniensegment definiert, das parallel zu dem ersten Liniensegment ist, wobei jede Mittellinie und die erste Achse näherungsweise parallel zu einer X-Achse (212a) sind, und wobei die Mittellinie (216) der ersten Quellenstruktur (204a) parallel zur Mittellinie (218) der zweiten Quellenstruktur (204b) ist, jedoch nicht mit dieser zusammenfällt, und die Längen der ersten und zweiten Liniensegmente entlang einer Y-Achse (212b) nicht gleich sind, und wobei die erste Quellenstruktur dafür ausgelegt ist, Licht mit einer ersten Wellenlänge zu einer ersten Zeit auszusenden, und die zweite Quellenstruktur dafür ausgelegt ist, das Licht mit der ersten Wellenlänge zu einer zweiten Zeit auszusenden, und die erste Quellenstruktur zu einer dritten Zeit Licht mit einer zweiten Wellenlänge aussenden kann, die von der ersten Lichtwellenlänge verschieden ist, und die zweite Quellenstruktur das Licht mit der zweiten Wellenlänge zu einer vierten Zeit aussenden kann.

2. Sensoranordnung nach Anspruch 1, wobei die Sensoranordnung Teil einer Messsonde ist, und wobei das optische Abbildungssystem ein Oximeter ist.

3. Vorrichtung nach Anspruch 1, zudem umfassend:

einen Strahlverbinder (124), der sowohl den ersten Lichtleiter als auch den zweiten Lichtleiter mit zwei unterschiedlichen Lichtquellen verbindet, die verschiedene Wellenlängen haben.

4. Vorrichtung nach Anspruch 1, wobei das Licht mit der ersten Wellenlänge Licht mit einer Wellenlänge von 690 Nanometern ist, und das Licht mit der zweiten Wellenlänge Licht mit einer Wellenlänge von 830 Nanometern ist.

5. Vorrichtung nach Anspruch 1, wobei die Anzahl Detektorstrukturen vier Detektorstrukturen (228a, 228b, 228c 228d) enthält.

6. Vorrichtung, umfassend eine Sensoranordnung, wobei die Sensoranordnung für den Gebrauch in einem optischen Abbildungssystem (100) geeignet ist, und die Sensoranordnung dafür ausgelegt ist, dass sie einen Körper berührt, wobei die Sensoranordnung umfasst:

eine erste Quellenstruktur (244a), die einen ersten Lichtleiter enthält, wobei die erste Quellenstruktur dafür ausgelegt ist, einen ersten Lichtstrahl zu liefern;

eine zweite Quellenstruktur (244b), die einen zweiten Lichtleiter enthält, wobei die zweite Quellenstruktur dafür ausgelegt ist, einen zweiten Lichtstrahl zu liefern; und

eine Detektoranordnung, wobei die Detektoranordnung eine erste Detektorstruktur (248a) enthält, die einen ersten Detektorlichtleiter umfasst, der einen ersten Detektormittelpunkt hat, und eine zweite Detektorstruktur (248d), die einen zweiten Detektorlichtleiter umfasst, der einen zweiten Detektormittelpunkt hat, und die Detektoranordnung dafür ausgelegt ist, dass sie den ersten Lichtstrahl empfängt und den zweiten Lichtstrahl, nachdem der erste Lichtstrahl und der zweite Lichtstrahl zumindest an dem Körper reflektiert wurden,

wobei die erste und die zweite Detektorstruktur so angeordnet sind, dass eine Mittellinie (254), die sowohl den ersten Detektormittelpunkt als auch den zweiten Detektormittelpunkt durchläuft, im Wesentlichen parallel zu einer X-Achse (252a) ist, und eine Schnittlinie (262), die parallel zu einer Y-Achse (252b) ist und senkrecht zu der Mittellinie (254) verläuft, durch einen Mittelpunkt zwischen dem ersten Detektormittelpunkt und dem zweiten Detektormittelpunkt geht, und eine Entfernung vom ersten Quellenmittelpunkt der ersten Quellenstruktur zur Schnittlinie (262) nicht gleich der Entfernung von einem zweiten Quellenmittelpunkt der zweiten Quellenstruktur zur Schnittlinie (262) ist, und wobei die erste Quellenstruktur dafür ausgelegt ist, Licht mit einer ersten Wellenlänge zu einer ersten Zeit auszusenden, und die zweite Quellenstruktur dafür ausgelegt ist, das Licht mit der ersten Wellenlänge zu einer zweiten Zeit auszusenden, und die erste Quellenstruktur zu einer dritten Zeit Licht mit einer zweiten Wellenlänge aussenden kann, die von der ersten Lichtwellenlänge verschieden ist, und die zweite Quellenstruktur das Licht mit der zweiten Wellenlänge zu einer vierten Zeit aussenden kann.

7. Vorrichtung nach Anspruch 6, zudem umfassend:

einen Strahlverbinder, der sowohl den ersten Lichtleiter als auch den zweiten Lichtleiter mit zwei unterschiedlichen Lichtquellen verbindet, die verschiedene Wellenlängen haben.

8. Vorrichtung nach Anspruch 6, wobei die Sensoranordnung ein Teil einer Messsonde ist, und wobei das optische Abbildungssystem ein Oximeter ist.

Revendications

1. Dispositif comprenant un agencement de capteur, l'agencement de capteur étant approprié pour une utilisation dans un système d'imagerie optique (100), l'agencement de capteur étant agencé pour venir en contact avec un corps, l'agencement de capteur comprenant :

une première structure de source (204a) comprenant une première fibre optique, la première structure de source étant agencée pour fournir un premier faisceau de lumière ;

une deuxième structure de source (204b) comprenant une deuxième fibre optique, la deuxième structure de source étant agencée pour fournir un deuxième faisceau de lumière ; et

un agencement de détecteur, l'agencement de détecteur comprenant une pluralité de structures de détecteur (208a, 208b) comprenant des fibres optiques qui ont chacune un point central, l'agencement de détecteur étant agencé pour recevoir le premier faisceau de lumière et le deuxième faisceau de lumière après que le premier faisceau de lumière et le deuxième faisceau de lumière ont été réfléchis au moins hors du corps,

dans lequel l'agencement de détecteur est agencé pour définir un premier axe (214) qui passe par le point central de chaque structure de détecteur (208a, 208b) de la pluralité de structures de détecteur, une distance d'un axe central (216) qui passe par un point central de la première structure de source (204a) jusqu'au premier axe (214) définit un premier segment de droite, une distance d'un axe central (218) qui passe par un point central de la deuxième structure de source (204b) jusqu'au premier axe (214) définit un deuxième segment de droite, qui est parallèle au premier segment de droite, dans lequel chacun des axes centraux et le premier axe sont à peu près parallèles à un axe x (212a), et dans lequel l'axe central (216) de la première structure de source (204a) est parallèle, mais ne coïncide pas avec l'axe central (218) de la deuxième structure de source (204b) et les longueurs des premier et deuxième segments de droite le long d'un axe y (212b) ne sont pas égales, et dans lequel la première structure de source est conçue pour émettre une première longueur d'onde de lumière à un premier instant, la deuxième structure de source est conçue pour émettre la première longueur d'onde de lumière à un deuxième instant, la première structure de source peut émettre une deuxième longueur d'onde de lumière, différente de la première longueur d'onde de lumière, à un troisième instant, et la deuxième structure de source peut émettre

- la deuxième longueur d'onde de lumière à un quatrième instant.
2. Agencement de capteur selon la revendication 1, dans lequel l'agencement de capteur fait partie d'une sonde, et dans lequel le système d'imagerie optique est un oxymètre. 5
3. Dispositif selon la revendication 1, comprenant en outre : 10
- un combineur de faisceaux (124) couplant chacune de la première fibre optique et de la deuxième fibre optique à deux sources de lumière différentes ayant différentes longueurs d'onde. 15
4. Dispositif selon la revendication 1, dans lequel la première longueur d'onde de lumière comprend une longueur d'onde de lumière de 690 nanomètres et la deuxième longueur d'onde de lumière comprend une longueur d'onde de lumière de 830 nanomètres. 20
5. Dispositif selon la revendication 1, dans lequel la pluralité de structures de détecteur comprend quatre structures de détecteur (228a, 228b, 228c, 228d). 25
6. Dispositif comprenant un agencement de capteur, l'agencement de capteur étant approprié pour une utilisation dans un système d'imagerie optique (100), l'agencement de capteur étant agencé pour venir en contact avec un corps, l'agencement de capteur comprenant : 30
- une première structure de source (244a) comprenant une première fibre optique, la première structure de source étant agencée pour fournir un premier faisceau de lumière ;
- une deuxième structure de source (244b) comprenant une deuxième fibre optique, la deuxième structure de source étant agencée pour fournir un deuxième faisceau de lumière ; et 40
- un agencement de détecteur, l'agencement de détecteur comprenant une première structure de détecteur (248a) comprenant une première fibre optique de détecteur qui a un premier point central de détecteur et une deuxième structure de détecteur (248d) comprenant une deuxième fibre optique de détecteur qui a un deuxième point central de détecteur, l'agencement de détecteur étant agencé pour recevoir le premier faisceau de lumière et le deuxième faisceau de lumière après que le premier faisceau de lumière et le deuxième faisceau de lumière ont été réfléchis au moins hors du corps, 45
- dans lequel les première et deuxième structures de détecteur sont agencées de sorte qu'un axe central (254) passant à la fois par le premier point central de détecteur et le deuxième point 55
- central de détecteur est sensiblement parallèle à un axe x (252a), une bissectrice (262) qui est parallèle à un axe y (252b) et perpendiculaire à l'axe central (254) passe par un point central entre le premier point central de détecteur et le deuxième point central de détecteur, une distance d'un premier point central de source de la première structure de source à la bissectrice (262) n'est pas égale à une distance d'un deuxième point central de source de la deuxième structure de source à la bissectrice (262), et dans lequel la première structure de source est conçue pour émettre une première longueur d'onde de lumière à un premier instant, la deuxième structure de source est conçue pour émettre la première longueur d'onde de lumière à un deuxième instant, la première structure de source peut émettre une deuxième longueur d'onde de lumière, à un troisième instant, et la deuxième structure de source peut émettre la deuxième longueur d'onde de lumière à un quatrième instant.
7. Dispositif selon la revendication 6, comprenant en outre : 20
- un combineur de faisceaux, couplant chacune de la première fibre optique et de la deuxième fibre optique à deux sources de lumière différentes ayant des longueurs d'onde différentes.
8. Dispositif selon la revendication 6, dans lequel l'agencement de capteur est une partie d'une sonde, et dans lequel le système d'imagerie optique est un oxymètre. 25

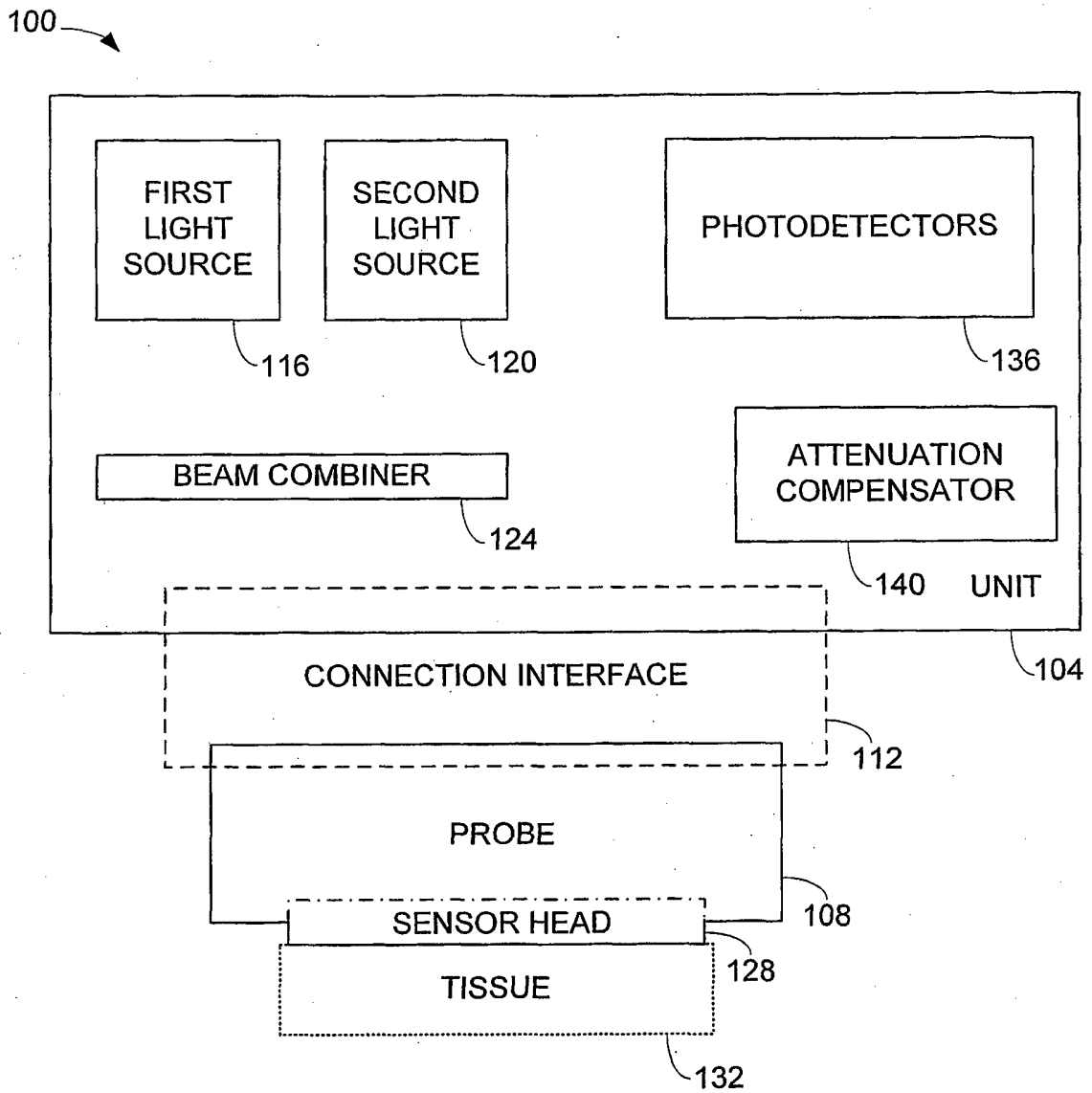

FIG. 1A

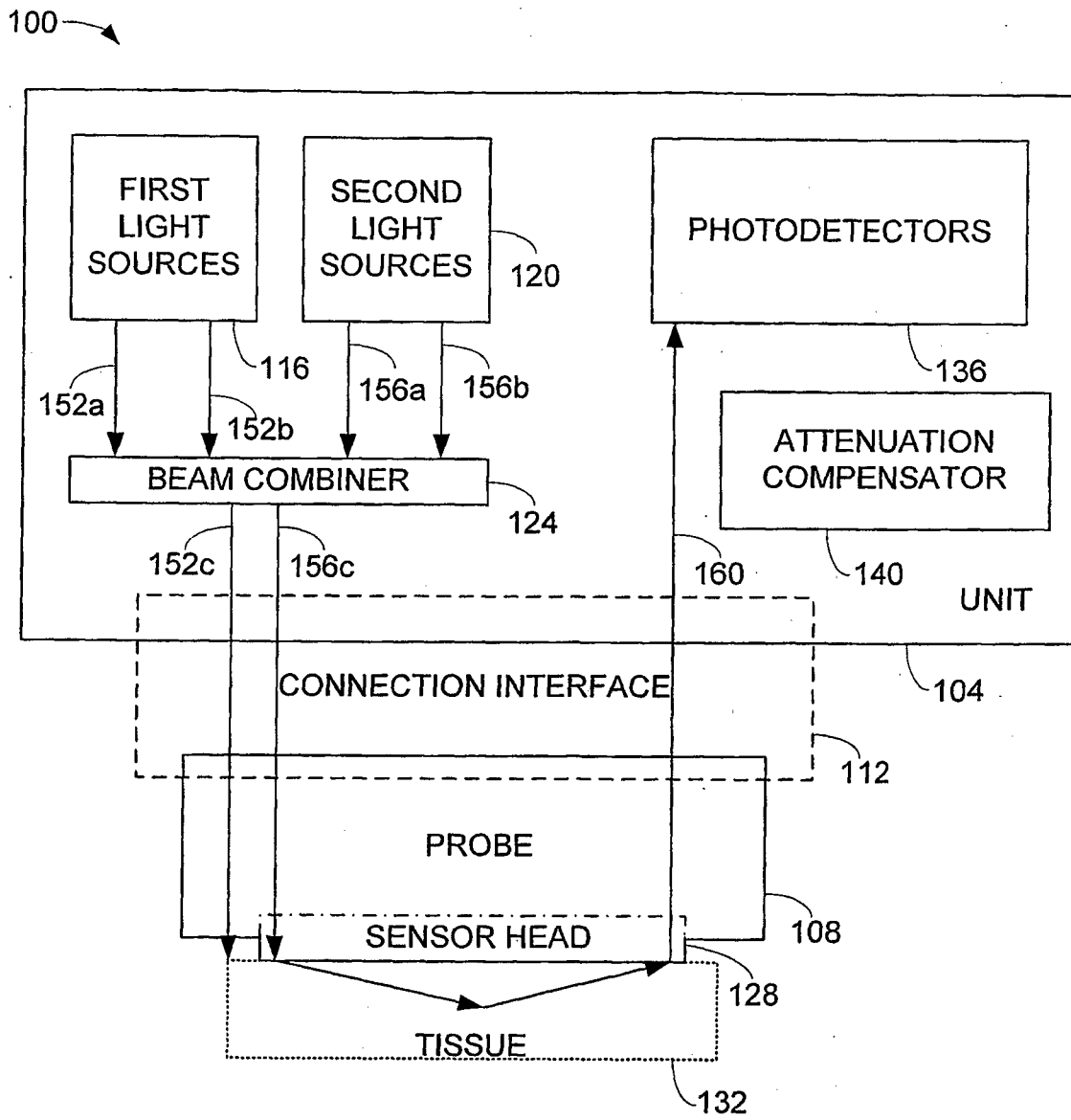
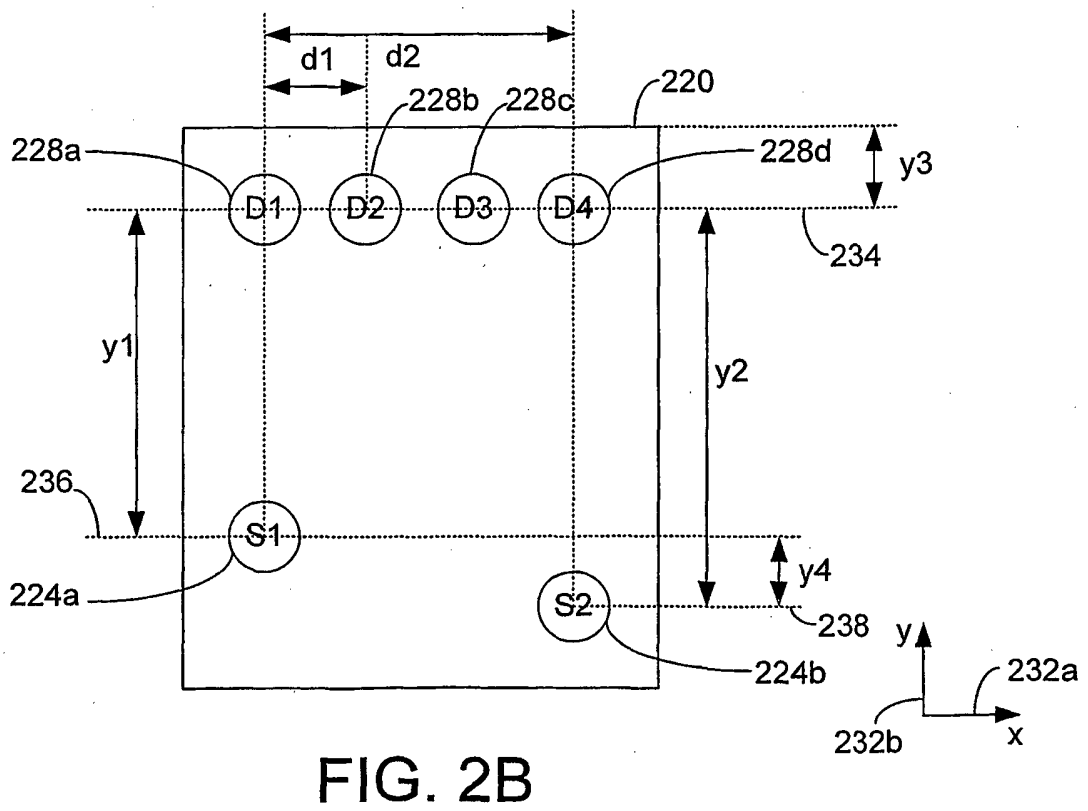
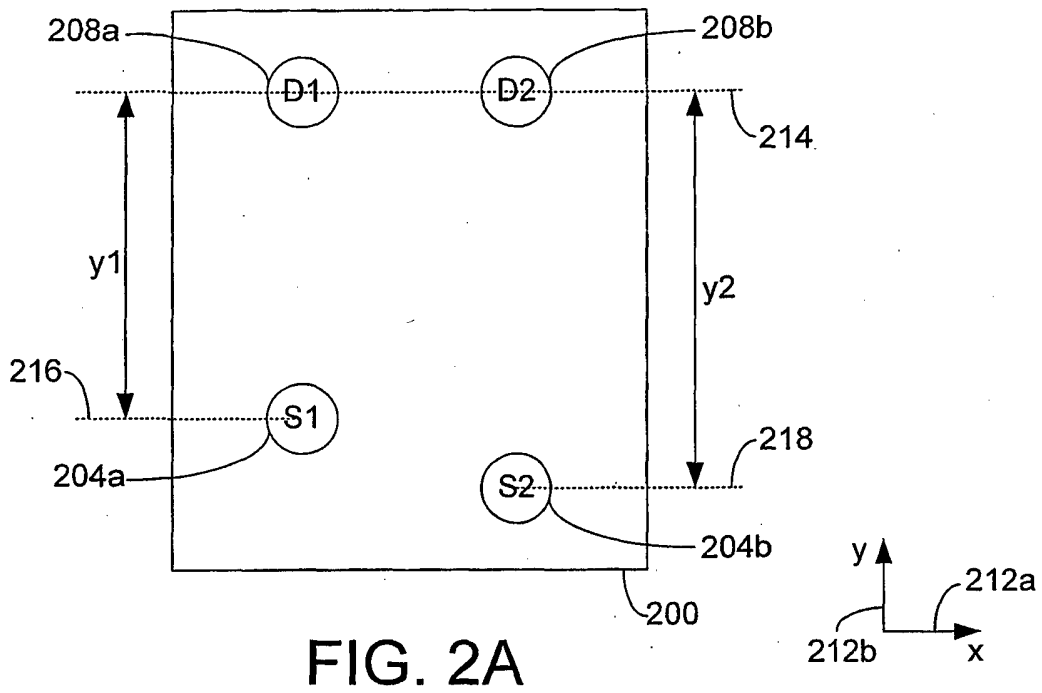

FIG. 1B



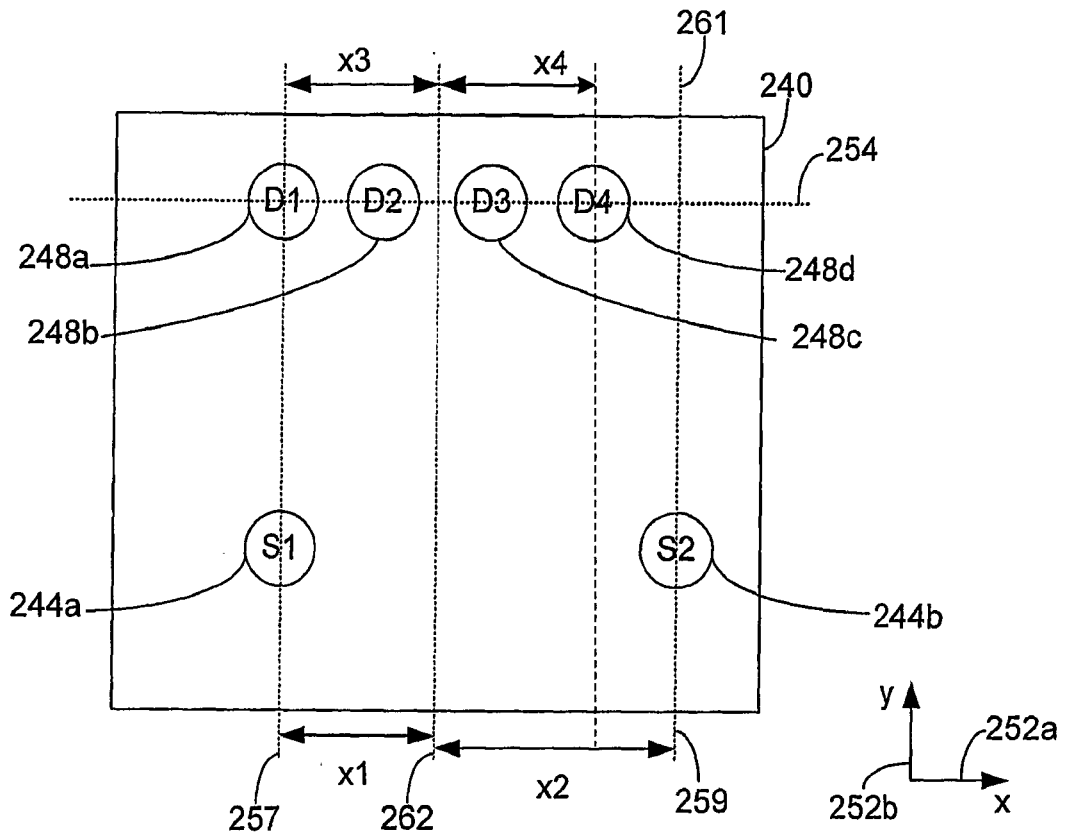

Figure 2C

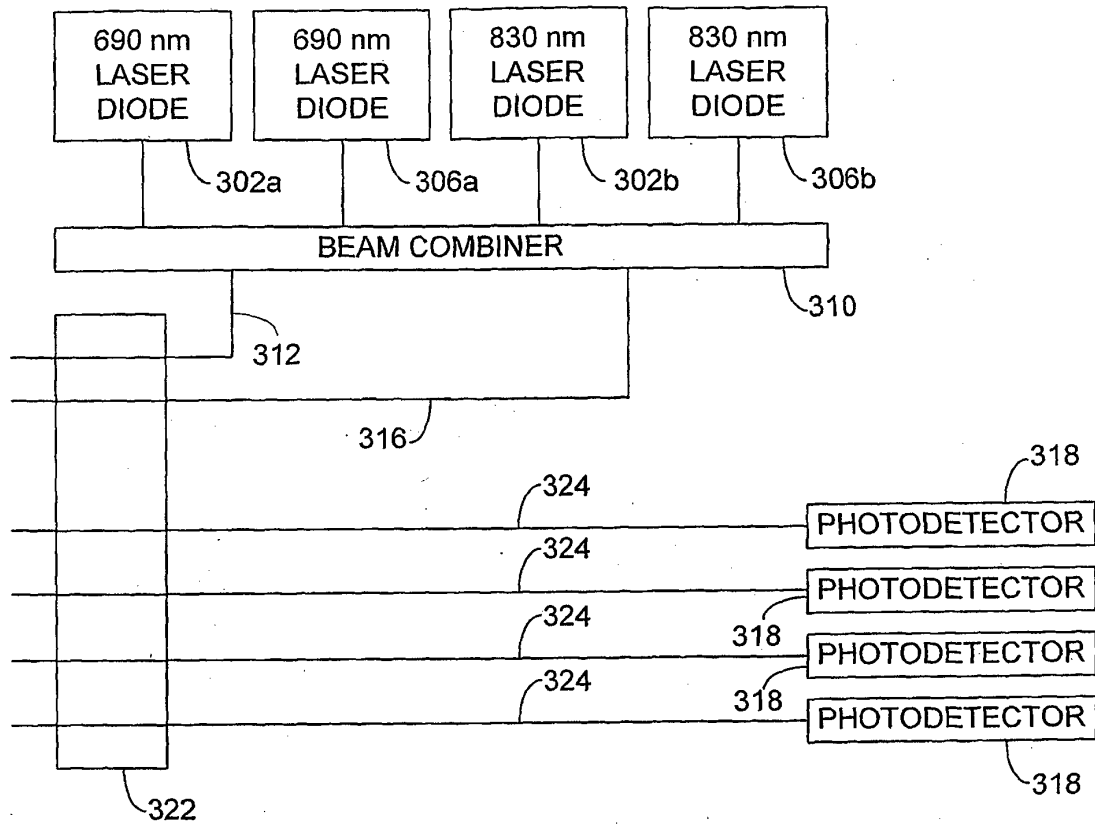

FIG. 3

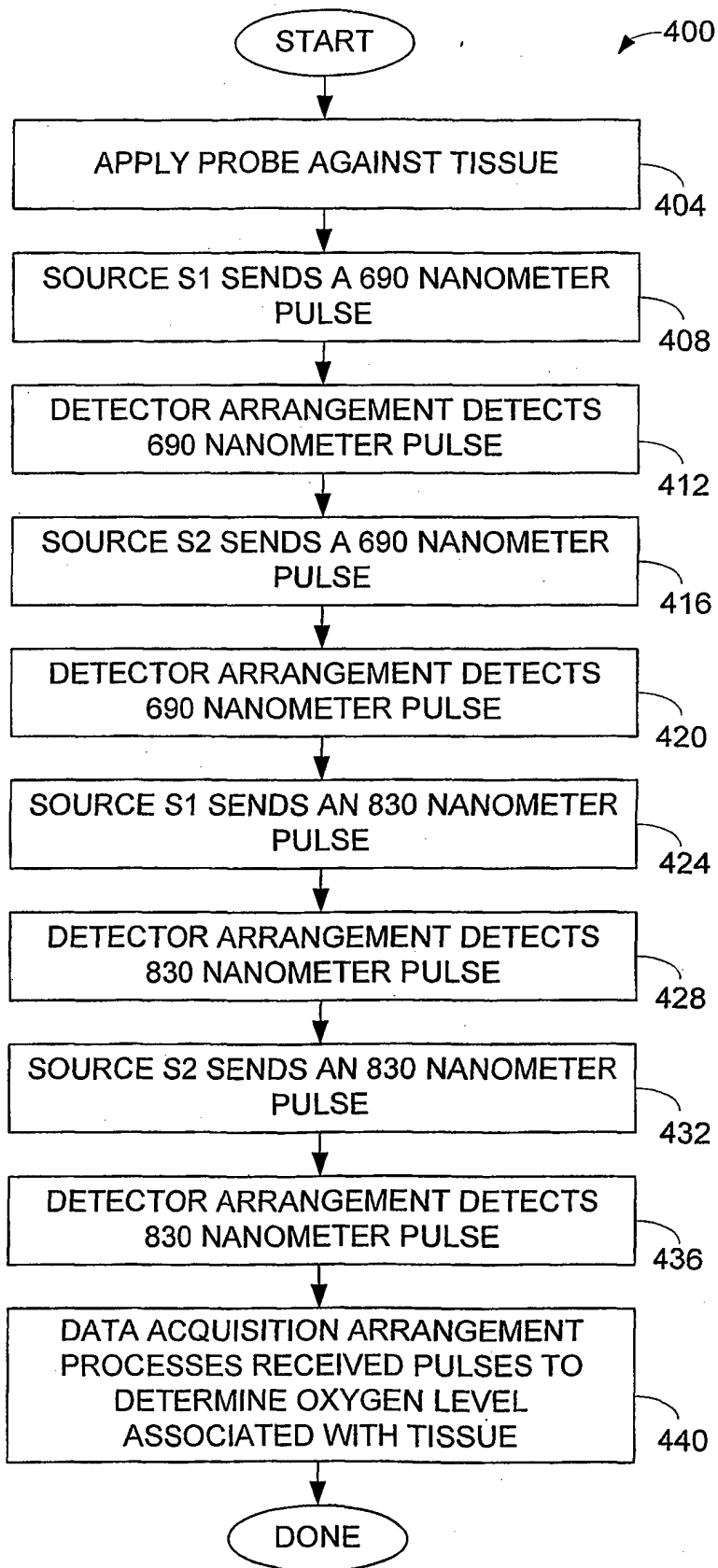

FIG. 4

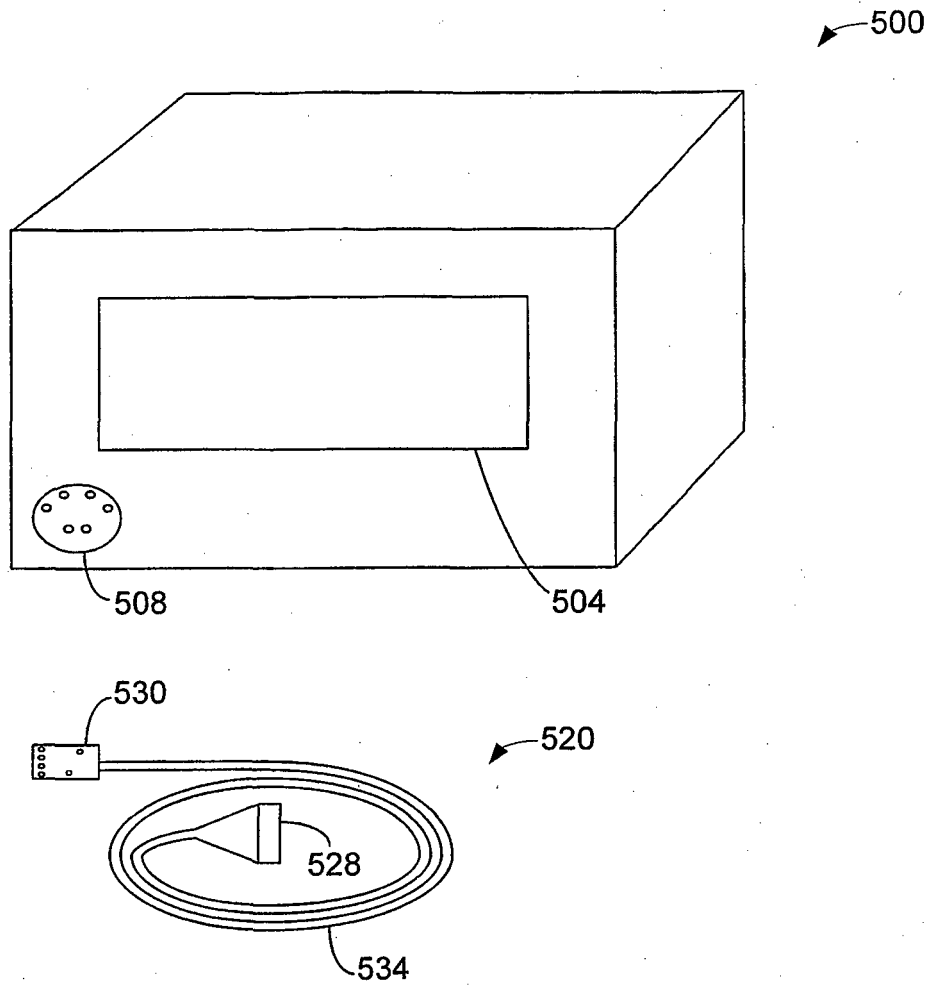

FIG. 5

REFERENCES CITED IN THE DESCRIPTION

This list of references cited by the applicant is for the reader's convenience only. It does not form part of the European patent document. Even though great care has been taken in compiling the references, errors or omissions cannot be excluded and the EPO disclaims all liability in this regard.

Patent documents cited in the description

- WO 0028887 A [0008]
- US 2003144583 A [0008]

专利名称(译)	用于光学成像系统的光学探针		
公开(公告)号	EP1921991B1	公开(公告)日	2013-10-09
申请号	EP2006802210	申请日	2006-08-24
[标]申请(专利权)人(译)	维奥普蒂克斯公司		
申请(专利权)人(译)	VIOPTIX INC.		
当前申请(专利权)人(译)	VIOPTIX INC.		
[标]发明人	LASH ROBERT MAO JIAN MIN LIN QIONG		
发明人	LASH, ROBERT MAO, JIAN-MIN LIN, QIONG		
IPC分类号	A61B5/1455 A61B5/00 A61B5/024 G01N21/31		
CPC分类号	A61B5/14552 G01N21/3151		
优先权	11/162376 2005-09-08 US		
其他公开文献	EP1921991A4 EP1921991A1		
外部链接	Espacenet		

摘要(译)

公开了用于监测组织中的氧饱和度水平的方法和设备。根据本发明的一个方面，一种用于光学成像系统的传感器装置包括第一源结构，第二源结构和检测器结构。第一源结构提供第一光束，第二源结构提供第二光束。该探测器装置包括具有中心点的探测器结构，并且在第一和第二光束被反射离开外表面之后接收第一和第二光束。探测器装置布置成限定穿过每个探测器结构的中心点的第一轴，并且从第一源结构的中心点到第一轴的距离不等于从第二源结构的中心点到第一轴的距离。第一轴。

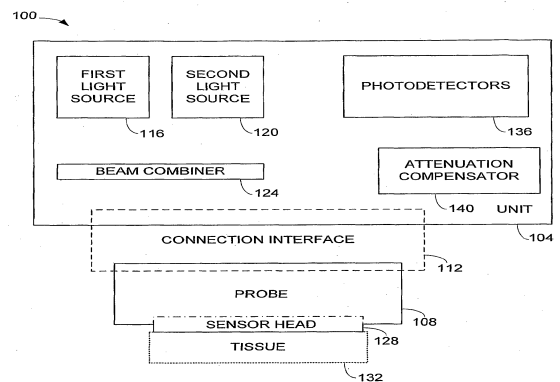

FIG. 1A