

(19)



(11)

**EP 2 621 333 B1**

(12)

**EUROPEAN PATENT SPECIFICATION**

(45) Date of publication and mention of the grant of the patent:  
**29.07.2015 Bulletin 2015/31**

(51) Int Cl.:  
**A61B 5/00 (2006.01) A61B 5/0478 (2006.01)**  
**A61B 5/1455 (2006.01)**

(21) Application number: **11768238.5**

(86) International application number:  
**PCT/US2011/053540**

(22) Date of filing: **27.09.2011**

(87) International publication number:  
**WO 2012/050847 (19.04.2012 Gazette 2012/16)**

---

(54) **DEPTH OF CONSCIOUSNESS MONITOR INCLUDING OXIMETER**

BEWUSSTSEINSTIEFENMONITOR MIT OXIMETER

APPAREIL DE SURVEILLANCE DU DEGRÉ DE CONSCIENCE AVEC OXYMÈTRE

(84) Designated Contracting States:  
**AL AT BE BG CH CY CZ DE DK EE ES FI FR GB GR HR HU IE IS IT LI LT LU LV MC MK MT NL NO PL PT RO RS SE SI SK SM TR**

- **ABDUL-HAFIZ, Yassir**  
**Irvine**  
**CA 92603 (US)**

(30) Priority: **28.09.2010 US 387457 P**

(74) Representative: **Vossius & Partner**  
**Patentanwälte Rechtsanwälte mbB**  
**Siebertstrasse 3**  
**81675 München (DE)**

(43) Date of publication of application:  
**07.08.2013 Bulletin 2013/32**

(73) Proprietor: **Masimo Corporation**  
**Irvine, CA 92618 (US)**

(56) References cited:  
**EP-A1- 0 541 393 WO-A1-00/21435**  
**US-A1- 2003 225 323 US-A1- 2007 208 269**

(72) Inventors:  
• **AL-ALI, Ammar**  
**San Juan Capristano**  
**CA 92675 (US)**

**EP 2 621 333 B1**

---

Note: Within nine months of the publication of the mention of the grant of the European patent in the European Patent Bulletin, any person may give notice to the European Patent Office of opposition to that patent, in accordance with the Implementing Regulations. Notice of opposition shall not be deemed to have been filed until the opposition fee has been paid. (Art. 99(1) European Patent Convention).

**Description**REFERENCE TO RELATED APPLICATIONS

**[0001]** This application is related to U.S. Provisional Patent Application No. 61/387426, titled "*Magnetic Electrical Connector For Patient Monitors*," filed on September 28, 2010.

FIELD OF THE DISCLOSURE

**[0002]** The present disclosure relates to the field of oximetry. More specifically, the disclosure relates to oximetry technologies for depth of consciousness monitoring.

BACKGROUND OF THE DISCLOSURE

**[0003]** General anesthesia is often used to put patients to sleep and block pain and memory during medical or diagnostic procedures. While extremely useful to caregivers, general anesthesia is not risk free, and thus, caregivers seek to maintain a depth of consciousness consistent with the needs of a particular medical procedure. In short, there is a desire to avoid over and under dosing. However, as a patient's depth of consciousness may change from minute to minute, caregivers often employ a host of monitoring technologies to attempt to periodically, sporadically, or continually ascertain the wellness and consciousness of a patient. For example, caregivers may desire to monitor one or more of a patient's temperature, electroencephalogram or EEG, brain oxygen saturation, stimulus response, electromyography or EMG, respiration, body oxygen saturation or other blood analytes, pulse, hydration, blood pressure, perfusion, or other parameters or combinations of parameters. For many of the foregoing, monitoring technologies are individually readily available and widely used, such as, for example, pulse oximeters, vital signs monitors, and the like.

**[0004]** In their depth of consciousness monitoring, caregivers may also use recording devices to acquire EEG signals. For example, caregivers place electrodes on the skin of the forehead to detect electrical activity produced by the firing of neurons within the brain. From patterns in the electrical activity, caregivers attempt to determine, among other things, the state of consciousness of the brain. Caregivers may also use cerebral oximeters to determine the percentage of oxygenation of the hemoglobin in the cerebral cavity inside the skull. Cerebral oximetry is different from conventional pulse oximetry, which detects the oxygenation of blood in the body arteries. However, like pulse oximetry, caregivers place sensors on the body, in this case on the forehead, that emit radiation and detect the radiation after attenuation by body tissue. This attenuated signal includes information relating to the blood oxygenation of the brain. Directly measuring the blood oxygenation of the brain, or at least measuring physiological parameters indicative of the blood oxygen-

ation of the brain, provides information about the state of brain function, such as, for example, brain oxygen consumption, not available by measurement parameters that determine only the oxygenation of the blood feeding the brain or by monitoring the brain's electrical activity.

**[0005]** Today, there are several approaches to implementing a cerebral oximeter. One approach includes placing emitters on the forehead and spacing detectors on the forehead at different distances from the emitters. The emitters emit radiation at two or four different wavelengths and the detectors output signals representing the detected attenuated radiation. An instrument compares a DC signal from the different detectors and uses the difference as a basis for measurement. The underlying assumption appears to be that the closer detector provides an indication of oxygen saturation of the tissue outside the cerebral cavity, while the further detector provides an indication of the oxygen saturation of the tissue outside and inside the cerebral cavity. Subtraction of the two is hoped to provide an indication of just cerebral oxygenation. In any event, caregivers use a rising or falling trend in this difference to make deductions about the cerebral oxygen status in the patient. In some cases, instruments employing four wavelength systems also seek an output value of oxygenation, as opposed to just a trend of the difference signal. The foregoing approaches appear to be consistent with commercially available instruments from Somanetics Corporation of Troy, MI and CAS Medical Systems, Inc. of Branford CT. A significant drawback to each of these approaches includes the cost of the instrumentation and sensors is often prohibitively high.

**[0006]** Another approach to a cerebral oximeter includes deep tissue imaging. For example, this type of research exposes high frequency light to the forehead and attempts to measure time of arrival and scattering/absorption coefficients. While primarily still in a research phase, it appears that the instrumentation could be less expensive than that disclosed above, perhaps even half the cost. However, even at that savings, this type of cerebral oximeter is still primarily in the research and development phase and still relatively costly. For example, the multiple optical benches provided in a single instrument generally associated with this type of design could cost more than three thousand dollars each. US 2007/208269 discloses a forehead sensor with a brain oxygenation sensor comprising a light source, a light detector and an EEG sensor.

**[0007]** Complicating the foregoing discussion is the realization that there is limited space on a patient's head for each of the different sensors. Particularly, where the forehead is the optimal measurement site in which to position EEG and brain oximetry sensors, drawbacks occur. For example, given the forehead's relatively small size, the forehead provides space for placement of a few sensors at the same time.

## SUMMARY OF THE DISCLOSURE

**[0008]** Based on at least the foregoing, the present disclosure seeks to overcome some or all of the drawbacks discussed above and provide additional advantages over any prior technologies. The present disclosure describes embodiments of noninvasive methods, devices, and systems for monitoring depth of consciousness through brain electrical activity and the oxygenation of the brain. Additional embodiments include monitoring of heartbeat, arterial oxygenation, venous oxygenation, temperature, and other physiological patient characteristics. For example, the present disclosure includes a combination forehead sensor having EEG and brain oximetry components. In an embodiment, the EEG components include electrical leads and the brain oximetry components include a plurality of light sources and detectors. Moreover, in an embodiment the forehead sensor includes a multi-site forehead sensor configured to be positioned above the eyebrows of a patient with connecting devices and cables traveling over the head and conveniently away from the body. Such positioning provides an ergonomic sensor along with increased safety from potential inadvertent interference by the patient or caregiver.

**[0009]** In an embodiment, a light source system of the sensor includes low cost optical benches having self contained internal emission detectors, light integrators or prisms, mirrors and the like. For example, in an embodiment, a light source includes a cap configured to reflect light toward a splitting mirror focusing light to both an internal emission detector for evaluation of the intensity of the emitted light and an aperture for directing the light into the patient's tissue. The light source may also include opaque or other surfaces or walls configured to appropriately direct emitted light.

**[0010]** Further embodiments may transform a commercially available pulse oximeter into a brain oximetry unit. For example, a processing device may advantageously connect to a sensor or other data input connection of a pulse oximeter to, for example, acquire power and open communication between the devices. In an embodiment, the sensor would include components for measuring the attenuation thereof. In an embodiment, the sensor would output a signal that represents the attenuated light. This signal would be similar to the output of a conventional pulse oximeter sensor in that both attempt to be indicative of light attenuation.

**[0011]** The signal could then be transmitted to the pulse oximeter for processing, conditioning and displaying of the brain oxygenation on a monitor of the pulse oximeter. A conventional pulse oximeter would be readily adaptable to process and display information from a brain oximeter sensor because the signals output by sensors of both devices are similar in nature (as both are output from photodiode light detectors detecting light attenuated by tissue). Modifications to the oximeter may advantageously include the algorithms used to analyze the signal from the sensors as cerebral oximeters may advantageously

use different wavelengths, frequencies, and different comparing and analysis techniques to determine oxygenation. However, one of ordinary skill will recognize from the disclosure herein that algorithm changes often are much more straightforward and price competitive than significant hardware changes. This is especially the case when updating an already-installed base of monitors.

**[0012]** In another embodiment, a forehead sensor for monitoring the depth of consciousness of a patient is disclosed comprising a brain oxygenation sensor that includes at least one light source and two detectors, an eeg sensor that includes electrical leads that make contact with the skin of the patient's forehead, a reusable portion that houses the light source and detectors of the brain oxygenation sensor and a disposable portion that houses a plurality of EEG electrodes and is removably connectable to the reusable portion. The connector of the forehead sensor may also connect to the disposable portion and the reusable portion and house the majority of the circuitry and processing components for the EEG sensor and the brain oxygenation sensor. In embodiment, an interface between the connector and the disposable portion may allow the disposable portion to be removably attached to the connector. The light source or detector may also have a lip around their edge. In an embodiment, the reusable portion is directly connected to the disposable portion.

**[0013]** In an embodiment, a system for monitoring the depth of consciousness of a patient is disclosed comprising a forehead sensor that includes a brain oxygenation sensor and a conventional pulse oximeter loaded with software for displaying data related to the blood oxygenation level of the brain cavity data processed by the forehead sensor. In an embodiment, the conventional pulse oximeter may provide power to the sensor and be capable of communicating data with the sensor or provide the drive signal and process the signal from the detector of the brain oxygenation sensor. The forehead sensor may also contain all of the components for processing the signal from detectors of the brain oxygenation sensor.

**[0014]** In another embodiment, a light source for a brain oxygenation sensor is disclosed comprising a substrate, emitters attached to the substrate for emitting light with at least two different wavelengths, a detector for detecting emitted light before it is attenuated by tissue, a cap connected to the substrate, and an aperture for the emitted light to exit the light source and enter the tissue site. The emitters may be LED's. In an embodiment a light diffusing material may be placed between the emitters and tissue site to scatter light. The light diffusing material may also be between the emitters and the detector and be made from a glass or epoxy that fills in around the emitters and detector. In an embodiment, the cap may be reflective or non-reflective. In another embodiment, a splitting mirror may direct light either to the detector or the aperture. In a further embodiment, a temperature sensor may be connected to the substrate.

**[0015]** For purposes of summarizing the disclosure, certain aspects, advantages and novel features of the disclosure have been described herein. Of course, it is to be understood that not necessarily all such aspects, advantages or features will be embodied in any particular embodiment of the disclosure.

#### BRIEF DESCRIPTION OF THE DRAWINGS

**[0016]** The following drawings and the associated descriptions are provided to illustrate embodiments of the present disclosure and do not limit the scope of the claims.

FIGURE 1A illustrates an embodiment of a forehead sensor communicating with a brain oximetry unit, which in turn communicates with a pulse oximeter now configured to monitor a state of consciousness through brain oxygenation.

FIGURE 1B illustrates an embodiment of the forehead sensor of FIGURE 1A including an ear pulse oximetry sensor.

FIGURE 2A - 2B illustrate block diagrams of embodiments of the brain oximetry unit of FIGURE 1A.

FIGURES 3A - 3O illustrate various embodiments of the forehead sensor of FIGURE 1A.

FIGURES 3A, 3N, and 3O illustrate embodiments of the forehead a sensor including reusable and disposable portions mated together.

FIGURES 3B - 3C illustrate embodiments of the reusable portion including various cerebral oximetry sensor components.

FIGURES 3D - 3M illustrate embodiments of the disposable portion including EEG, temperature and other parameter measuring components.

FIGURES 4A - 4O illustrate various embodiments and views of light sources of the forehead sensor of FIGURE 1A.

FIGURE 4A - D illustrate perspective and side views of a light source of the cerebral oximeter according to embodiments of the present disclosure.

FIGURE 4E illustrates a perspective view of the light source including light paths of a multi-faceted directing mirror according to an embodiment of the present disclosure.

FIGURE 4F - G illustrate more perspective views of the light source.

FIGURE 4H illustrates a further perspective view of the light source without a cap according to an embodiment of the present disclosure.

FIGURE 4I illustrates a bottom view of the light source towards the top reflective covering according to an embodiment of the present disclosure.

FIGURE 4J illustrates a perspective view of the light source with the reflective cover being composed of many portions according to an embodiment of the present disclosure.

FIGURES 4K - 4M illustrate side views of the light

source including a semi-reflectant mirror according to an embodiment of the present disclosure.

FIGURE 4N illustrates a side view of the light source including a light diffusing material filling inside a cap according to an embodiment of the present disclosure.

FIGURE 4O illustrates a side view of the light source with an angled substrate according to an embodiment of the present disclosure.

FIGURE 4P illustrates a side view of the light source with a relatively flat cap.

FIGURE 5 illustrates an exemplary graph showing the calibrated relationship of the emission detector output to the calibrated intensity of the emitter output according to an embodiment of the present disclosure.

FIGURE 6 illustrates an embodiment of a forehead sensor communicating with a brain oximetry unit contained inside a connector, which in turn communicates with a pulse oximeter configured to monitor and/or display a state of consciousness through brain oxygenation.

FIGURES 7A - 7E illustrate various embodiments and views of the forehead sensor of FIGURE 6.

FIGURE 7A illustrates a perspective view of the sensor and connector with the disposable portion of the forehead sensor detached from the connector.

FIGURE 7B illustrates a top view of the forehead sensor with the disposable and reusable portion of the sensor connected.

FIGURE 7C illustrates a side view of the forehead sensor with both the disposable and reusable portion of the sensor connected.

FIGURE 7D illustrates a front view of the forehead sensor with both the disposable and reusable portion of the sensor connected.

FIGURE 7E illustrates a bottom view of the forehead sensor with the disposable and reusable portion connected.

FIGURES 8A - 8D illustrate various embodiments and views of the forehead sensor that include an EEG sensor.

FIGURE 8A illustrates a perspective view of the sensor and connector with the disposable portion of the forehead sensor detached from the connector.

FIGURE 8B illustrates a top view of the forehead sensor with the disposable and reusable portion of the sensor connected.

FIGURE 8C illustrates a side view of the forehead sensor with both the disposable and reusable portion of the sensor connected.

FIGURE 8D illustrates a bottom view of the forehead sensor with the disposable and reusable portion connected.

FIGURES 9A - 9E illustrate various embodiments and views of the reusable portion of the forehead sensor.

FIGURE 9A illustrates a perspective view of the re-

usable portion and connector of the forehead sensor with the reusable portion detached from the connector.

FIGURE 9B illustrates a top view of the reusable portion of the forehead sensor.

FIGURE 9C illustrates a side view reusable portion of the forehead sensor.

FIGURE 9D illustrates a front view of the reusable portion of the forehead sensor.

FIGURE 9E illustrates a bottom view of the reusable portion of the forehead sensor.

FIGURES 10A - 10D illustrate various embodiments and views of the reusable portion of the forehead sensor.

FIGURE 10A illustrates a top view of the reusable portion of the forehead sensor.

FIGURE 10B illustrates a side view reusable portion of the forehead sensor.

FIGURE 10C illustrates a bottom view of the reusable portion of the forehead sensor.

FIGURE 10D illustrates an exploded perspective view showing an embodiment of the various layers of the reusable portion of the forehead sensor.

FIGURES 11A - 11E illustrate various embodiments and views of the connector of the forehead sensor.

FIGURE 11A illustrates an exploded perspective view of the various components of the connector.

FIGURE 11B illustrates a top view of the connector.

FIGURE 11C illustrates a front view of the connector.

FIGURE 11D illustrates a side view of the connector.

FIGURE 11E illustrates a bottom view of the connector.

FIGURES 12A - 12D illustrate various embodiments and views of the disposable portion of the forehead sensor.

FIGURE 12A illustrates a perspective view of the disposable portion of the forehead sensor with a detached adhesive layer.

FIGURE 12B illustrates a top view of the disposable portion of the forehead sensor.

FIGURE 12C illustrates a side view of the disposable portion of the forehead sensor.

FIGURE 12D illustrates a bottom view of the disposable portion of the forehead sensor that includes an attached adhesive layer.

FIGURES 13A - 13D illustrate various embodiments and views of the disposable portion of the forehead sensor that include an EEG sensor.

FIGURE 13A illustrates an exploded perspective view of the disposable portion of the forehead sensor with a detached adhesive layer.

FIGURE 13B illustrates a top view of the disposable portion of the forehead sensor.

FIGURE 13C illustrates a side view of the disposable portion of the forehead sensor.

FIGURE 13D illustrates a bottom view of the disposable portion of the forehead sensor that includes an attached adhesive layer.

FIGURE 14 illustrates an embodiment of an exemplary display showing potential brain oximetry parameters that could be displayed in an embodiment of the brain oximetry sensor.

5

#### DETAILED DESCRIPTION

**[0017]** The present disclosure generally relates to patient monitoring devices. In order to provide a complete and accurate assessment of the state of a patient's various physiological systems, in an embodiment, a sensor may advantageously monitor one, multiple or combinations of EEG, cerebral oximetry, temperature, pulse oximetry, and other physiological parameters. In various embodiments, the sensor includes a disposable portion and reusable portion. For example, the disposable portion may advantageously include components near a measurement site surface (the patient's skin), including, for example, an EEG, a temperature sensor, tape, adhesive elements, positioning elements, or the like. On the other hand, the reusable portion may advantageously include more expensive or other components, circuitry or electronics, which, in some embodiments include for example time-of-use restrictions for quality control or the like. The reusable portion, can be used multiple times for a single patient, across different patients, or the like, often depending upon the effectiveness of sterilization procedures. The reusable components may include, for example, cerebral oximetry components, pulse oximetry components and other components to measure other various parameters.

**[0018]** In an embodiment, the disposable portion of the sensor may include an inductance connection or other electrical connection to the reusable portion of the sensor, and the signal from both sensors could thereby be transmitted through a common cable to a brain oximetry unit. In an embodiment, the brain oximetry unit may include an analog to digital converter, various electrical filters, and a microcontroller for processing and controlling the various sensor components.

**[0019]** In an embodiment, a brain oximetry unit or additional signal processing unit could communicate with the forehead sensor disclosed herein and one or more host display and patient monitoring stations. In an embodiment, the patient monitoring station may be a pulse oximeter. In an embodiment, the pulse oximeter may perform integrated display, data monitoring, and processing of patient parameters including a connection for power and data communication. In an embodiment, some or all communication may be through wired, wireless, or other electrical connections. In an embodiment, the brain oximetry unit may advantageously be housed in a portable housing. In such embodiments, the unit may advantageously be physically associated with a monitored patient, such as, for example, attached in an arm band, a patient bed pouch, a hood or hat, a pocket of a shirt, gown, or other clothing, or the like. In other embodiments, the unit may be entirely or partially housed in a cable

connector. In an embodiment, the signal processing and condition unit could also monitor patient parameters through other sensors including, for example, ECG, SpO<sub>2</sub> from the earlobe, finger, forehead or other locations, blood pressure, respiration through acoustic or other monitoring technologies, or other clinically relevant physiological parameters.

**[0020]** In an embodiment, the pulse oximeter communicates with a sensor, such as a forehead sensor including one or more light sources configured to emit light at a patient's forehead. In an embodiment, the light source may include one or more emitters or emitter systems, such emitters or emitter systems may be embedded into a substrate. In various embodiments, the emitters could be either light emitting diodes ("LEDs"), lasers, superluminescent LEDs or some other light emitting components. These components could be arranged in any pattern on the substrate and could be either a single light emitting source or several light emitting sources. In an embodiment, the emitting components could emit light that deflects off of reflective surfaces associated with a cap of the substrate. The reflective cover could be any number of shapes or sizes and could be constructed to direct light to specific points or a point on the cap or substrate.

**[0021]** In an embodiment, a multi-faceted splitting mirror could reflect light to an opening in the substrate that would allow the light to escape and be emitted to an emission detector in an embodiment also housed in the light source substrate. The emission detector may advantageously sample the light providing feedback usable to create an optical bench or at least optical bench properties of the light source, including, for example, determinations of intensity, wavelength, or the like. In an embodiment, the light source may include a polarized filter for adjusting the emitter light, in some embodiments before exiting an opening in the emitter or being detected by the emission detector.

**[0022]** In an embodiment, a caregiver could analyze physiological information collected from the various sensors including a patient's temperature, EEG, brain oxygen saturation, stimulus response, electromyography or EMG, respiration monitor using acoustic sensor applied to the through, body oxygen saturation, glucose concentration, or other blood analytes, pulse, hydration, blood pressure, perfusion, or other parameters or combinations of parameters to determine relevant information about the state of a patient's well being. In another embodiment, a caregiver may advantageously analyze information collected from the various sensors to more completely assess the overall depth of a patient's sedation and obtain an assessment superior to an assessment derived from monitoring a single or a few of the parameters mentioned above.

**[0023]** Reference will now be made to the Figures to discuss embodiments of the present disclosure.

**[0024]** FIGURE 1A and 1B illustrate examples of a patient monitoring system 100. In certain embodiments, the

patient monitoring system 100 measures several physiological parameters including cerebral electrical activity, temperature, cerebral oxygenation, including venous and arterial oxygenation, arterial oxygenation at various other points on the body, various other blood analytes including total hemoglobin, glucose, lipids, stimulus response, electromyography or EMG, respiration, pulse, hydration, blood pressure, perfusion, or other parameters or combination of other physiologically relevant patient characteristics. The information from these physiological parameters can be evaluated using trend analysis, absolute and relative measures of certain parameters, combined or alone to evaluate the total wellness and current state of a patient at any point in time.

**[0025]** The patient monitoring system can include multiple or a single sensor 120, a brain oximetry unit 140, and a pulse oximeter 150. The sensor 120 can be any variety of shapes and sizes, and could be applied to a variety of measurement sites on a patient's skin including any location on the forehead and temples or other location of the head. Also, electrodes designed to be placed at a measurement site covered with a patient's hair may advantageously be implemented in order to apply the sensor to any part of a patient's head that is covered with hair. A caregiver or patient may fasten the sensor to the patient's head with a variety of mechanism including adhesive, straps, caps, combinations of the same, or other devices for fastening sensors to a patient's body or skin known in the art.

**[0026]** In an embodiment, the patient monitoring system 100 advantageously utilizes wireless communication to provide a portable unit to accommodate an ambulatory patient, or other patient in transit. For example, in one embodiment, the brain oximetry unit 140 may be attached to an arm band or included in an arm band or other device that is wearable by the patient, including in a cap, a hood, a sling or a pocket of a garment. In an embodiment, the sensor would communicate with the arm band brain oximetry unit 140 with a hard wired connection or a wireless connection for convenience and flexibility of the patient obtained by eliminating excess wires.

**[0027]** In an embodiment, the portable brain oximetry unit 140, such as an armband brain oximetry unit 140, could also communicate wirelessly with the pulse oximeter 150. This would allow the brain oximetry unit 140 to be transported between various caregiving facilities, each with their own stationary pulse oximeters 150 without unhooking and reinserting hardwired electrical connections. Instead, a brain oximetry unit 140 could establish a wireless communication link with a stationary pulse oximeter 150 as the brain oximetry unit 140 is brought into proximity of the pulse oximeter 150. In an embodiment, the devices could establish the connection automatically and patient data may be automatically sent from the brain oximetry unit 140 to the pulse oximeter 150 or the connection may require input from a caregiver in the user interface of either of the devices. This will advantageously facilitate portability and seamless monitoring of

a patient while being transported, for example, from an ambulance to a hospital room or from room to room in a hospital.

**[0028]** In an embodiment, the pulse oximeter 150 may be a multi-parameter patient monitoring station or other host device capable of monitoring a wide variety of vital signs and blood constituents and other parameters or combinations of parameters such as those monitors commercially available from Masimo Corporation of Irvine, CA, and disclosed herein with reference to U.S. Patent No. 6584336, 6661161, 6850788, and 7415297, among others assigned to Masimo Corporation, and U.S. Patent Publication No. 2006/0211924, 2010/0030040, among others assigned to Masimo Corporation or Masimo Laboratories, Inc. of Irvine CA.

**[0029]** FIGURE 1B illustrates an embodiment of the patient monitoring system 100 with a pulse oximeter 150 attached to a sensor 120 or through some physical electrical conduction connection, wireless, or other suitable electrical connection to the pulse oximeter 150. This will advantageously provide additional information about the state of the arterial oxygenation of the blood being transported to the head. In an embodiment, the pulse oximeter 150 branches off the wiring from the sensor 120.

**[0030]** In an embodiment, a caregiver or the patient may attach the brain oximetry unit 140 directly to the patient's arm or other part or clothing of the patient through an armband with straps or some other means known in the art to connect a portable monitoring unit to a patient. In an embodiment, a brain oximetry unit 140 may be integrated into a hat or other headgear wearable by the patient or some other structure near the patient. In an embodiment, brain oximetry unit 140 can rest on a table or other surface near the patient.

**[0031]** In some embodiments, a brain oximetry unit 140 can be integrated with the pulse oximeter 150. Alternatively, the brain oximetry unit 140 could be a module that is docked or somehow associated with a multi-parameter patient monitoring station.

**[0032]** FIGURE 2A and 2B show block diagrams of various embodiments of the brain oximetry unit 140, sensors 120, and pulse oximeter 150. In an embodiment, the brain oximetry unit 140 may utilize a processor 220 which may be a micro-controller or other processor, which may control or coordinate some or all of the functions of the various emitters 230 and detectors 260 and other sensors 120 and in an embodiment, may coordinate, process or condition, or manipulate the electronic data in some other manner, before communicating the data to the pulse oximeter 150. Also, the processor 220 may receive instructions or data control messages from the pulse oximeter 150 to provide the appropriate conditioning and controlling of the various front end components of the various sensors 120 associated the pulse oximeter 150. In an embodiment, data transmitted between the brain oximetry unit 140, the pulse oximeter 150, the sensors 120 and any other associated components of a patient monitoring system 100 may be communicated by the devices using

electrical wires, wireless communication, optical communication, RFID, LAN networks, or other electronic devices for communicating data known in the art.

**[0033]** The brain oximetry unit 140 may also include various front end components for the various sensors 120 that may be associated with the brain oximetry unit 140. In an embodiment, front end components may translate and transmit instructions and control signals for driving the various sensors. In an embodiment, the front end components may translate, process, or transmit instructions and control signals to the emitting or light producing components of the sensor. The front end components may also receive and transmit data acquired by the detectors of the sensors to the microcontroller 220 or other processor 220.

**[0034]** These front end components could include front end components for a variety of sensors 120 including for sensors that detect blood oxygenation, EEG, ECG, temperature, acoustic respiration monitoring ("ARM") sensors, such as those available from Masimo Corporation of Irvine, CA, acoustic throat respiratory sensor, and brain oxygenation. In an embodiment, a caregiver could advantageously utilize a device with the ability to monitor the plurality of above mentioned parameters to more accurately determine a depth of a patient's sedation. In an embodiment, a front end component that would be associated with a sensor 120 that detects brain oxygenation may have a sub component dedicated to driving emitters 230 associated with a light source of the brain oxygenation sensor and a sub-component associated with the detector 230 or detectors 230 of the brain oxygenation sensor 300 for receiving and transmitting the detected signals that pass through various body tissues.

**[0035]** In an embodiment, one of the various sensors associated with the front end components of the brain oximetry unit could be, for example, a blood oxygenation sensor 310 which may be placed at various measurement sites on a patient's skin, including the earlobe, finger, forehead or other places known in the art suitable for detecting blood oxygenation. Many suitable pulse oximeter sensors 310 are known in the art such as those blood oxygenation sensors 310 commercially available from Masimo Corporation of Irvine, CA, and disclosed herein with reference to U.S. Patent No. 5638818, 6285896, 6377829, 6580086, 6985764, 7341559, or others.

**[0036]** In an embodiment, another sensor 120 that may be associated with a front end component of the brain oximetry unit 140 could be a temperature sensor 320. The temperature sensor 320 could detect the temperature of the skin, the temperature inside the ear, the temperature under the tongue, or any other temperature measurement method known in the art. In an embodiment, the temperature sensor 320 could be any suitable thermistor, or any other temperature sensor 320 known in the art capable of detecting a surface temperature of a patient's skin. Additional temperature sensor may advantageously provide feedback to the unit 140 regarding

the performance or temperature of one, combinations of, or all of the emitters 230.

**[0037]** An EEG sensor 330 may also be associated with the front end components of the cerebral oximeter 140. In an embodiment, the EEG sensor 330 may be any of a variety of EEG sensors 330 known in the art. An EEG sensor 330 could be applied to a patient at any of a multitude of locations and measurement sites on the skin of the head of a patient. In an embodiment, the EEG sensor 330 may include electrode leads that may be placed on a measurement site in contact with the skin of the patient. In an embodiment, the EEG 330 may monitor the electrical activity of a patient's brain through any number of electrodes, electrode leads, and channels or other systems known in the art.

**[0038]** In an embodiment, the EEG sensor 330 may monitor and collect data from a patient's brain using 4 channels and 6 electrodes. In another embodiment, the EEG 330 may use 3 channels and 5 electrodes. In another embodiment, any variety or combination of sensors may be used that are suitable for obtaining an EEG signal, for example, such a system is disclosed in U.S. Patent No. 60164444, 6654626, 6128521, or the like.

**[0039]** A brain oxygenation sensor 300 may also be associated with the front end components of the brain oximetry unit 140. In an embodiment, the brain oxygenation sensor 300 includes a light source 230, and a detector 260. The light source 230 of the brain oxygenation sensor 300 includes emitter(s) that would emit light, sonic or other radiation into the forehead at one, two or other plurality of measurement sites located on the skin of the patient at a plurality of predetermined wavelengths. In an embodiment, the brain oxygenation sensor 300 would include a detector 260 with photodiodes or other radiation detection devices to detect the radiation emitting from the patient at a one or two or a plurality of measurement sites on the skin of the head of a patient. Many suitable brain oxygenation sensors 300 and cerebral oximeters are known in the art including those disclosed in U.S. Patent No. 7072701, 7047054, or similar sensors.

**[0040]** In an embodiment, the light source 230 of the brain oxygenation sensor 300 may include an emission detector 260. In an embodiment, the emission detector 260 would detect the light emitted from the light source 230 before passing through or contacting the measurement site of the patient. In an embodiment, an output from the emission detector 230 would be communicated to the micro-controller 220 in the brain oximetry unit 140, the processing unit in the cerebral oximeter 140 or, some other processing component associated with the patient monitoring system 100 in order to calculate an approximate output intensity of the light emitted by the emitter(s) 230. The micro-controller 220 or other processor 220 could calculate the output intensity based on the output of the emission detector 260 by comparing the data to calibration data. In an embodiment, the calibration data could include measurement of intensity of light emitted from the emitter(s) 230 and corresponding measure-

ments of output from the emission detector 260. This data could then be correlated to real time output from the emission detector 260 while the oxygenation sensor 230 is in use to determine an actual or approximate intensity of light or radiation being emitted by the emitter(s) 230 utilizing a calibration curve or other suitable calculation or processing method. In an embodiment, the calibration data may be stored in an EPROM or other memory module in the brain oximetry unit 140, the pulse oximeter 150, or other patient processing module associated with the patient monitoring system 100.

**[0041]** In an embodiment, the detector 260 will detect light or other radiation emitted from the light source 230 after, in an embodiment, some of the light has entered the measurement site on the patient and has been attenuated by a patient's tissue. In an embodiment, the detector 260 could be any number of detectors known in the art for detecting light or other radiation including photodiodes or other types of light or radiation detectors. In one embodiment, the detector 260 may convert detected light or other radiation into a signal, for example, an electrical output signal, which may represent the intensity or other attributes of the radiation. In an embodiment, the signal from the detector 260 may be sent to a brain oxygenation detector 260 front end located in the brain oximetry unit 140 for processing, conditioning or transmitting to the pulse oximeter 150 or other patient monitoring processor. In one embodiment, the signal may be converted into a digital format by an analog to digital converter located in either the brain oximetry unit 140 or the pulse oximeter 150. In an embodiment, the data from the detector 260 of the brain oxygenation sensor 300 may be processed to determine the cerebral oxygenation of a patient's brain tissue. In an embodiment, the processing of the data may include determining the changes of intensity between various wavelengths of emitted and detected light of the cerebral oxygenation sensor 300.

**[0042]** In an embodiment, the cerebral oximeter 150 or multi-parameter patient monitor acquires data from the brain oximetry unit 140 or sensor 120 derived from physiologically relevant parameters. In an embodiment, the pulse oximeter 150 could give visual quantitative or qualitative assessments of the patient's well being based on one or more of the various parameters or physiological attributes measured.

**[0043]** In an embodiment, a caregiver may utilize various physiological parameters to make a quantitative assessment of the patient's depth of sedation as indicated by an index based on for example, a patient's temperature, electroencephalogram or EEG, brain oxygen saturation, stimulus response, electromyography or EMG, respiration based on acoustic through sensors, body oxygen saturation or other blood analytes, pulse, hydration, blood pressure, perfusion, or other parameters or combinations of parameters. In another embodiment, various aspects of sedation could be assessed quantitatively or qualitatively based on a visual representation of the patient's sedation in the aspects including hypnosis, re-

sponsiveness, muscle relaxation or other clinically relevant facets of depth of anesthesia.

**[0044]** In an embodiment, the pulse oximeter 150 may supply power to brain oximetry unit 140 over a single line and data would be transferred back and forth between the brain oximetry unit 140 and pulse oximeter 150 over a separate line or lines. In another embodiment, both power and data could be transmitted over the same line or the same wire with multiple lines in the wire. In another embodiment, data and power could be transmitted wirelessly or through an inductance connection between the patient monitoring station and the signal processing unit or any other suitable connections or transmission techniques known in the art. Induction or magnetic connections are also disclosed in U.S. Pat. App. No. ###/###,###, titled "Magnetic Electrical Connector for Patient Monitors," filed herewith on Sept. 27, 2011.

**[0045]** In an embodiment, the functionality of the brain oximetry unit 140 could be optionally controlled by the pulse oximeter 150. In an embodiment, the data and qualitative and quantitative assessments of a patient's wellness being could be displayed on either or both the brain oximetry unit 140 and pulse oximeter 150. Also, audible alarms and other indicators could be displayed on either or both the brain oximetry unit 140 and pulse oximeter 150 in response to various threshold breaches based on the assessment of the patient's wellness determined from the various monitored parameters.

**[0046]** FIGURES 3A - 3F illustrate several embodiments of the sensor 120. FIGURE 3A shows an embodiment of the sensor 120 wherein disposable 410 and reusable portions 420 of the sensor 120 are connected and overlaid on top of one another. FIGURE 3A shows six EEG electrodes 440 with two reference electrodes and four active channel electrodes. FIGURE 3A also shows the light source 230 and detector 260 components of the brain oxygenation sensor 300. Any number of suitable light sources 230 and detectors 260 may be incorporated into the forehead sensor 120. All or some of the above mentioned sensor components including the EEG leads 440 and the brain oxygenation emitter 230 and detector 260 components may be linked to a single chip for transmission of acquired signals and drive signals or each component may be linked to its own individual chip through wires, or printed circuits, or other suitable electrical connections.

**[0047]** In one embodiment, the light source 230 may include one or more emitters. In one embodiment, the emitter could be a laser, or any suitable apparatus for emitting near-infrared or other spectrum of light including LEDs, super luminescent LEDs, or some other light emitting components. In one embodiment, the light source 230 may be incorporated with the brain oximetry unit 140 and the light or other radiation could be emitted from the light source 230 onto a fiber optic cable which would transmit the light from the light source 230 to the measurement site. In another embodiment, the emitter(s), including, for example, a laser or LED emitter(s), is em-

bedded in the emitter 230 directly in the forehead sensor. Other fiber optics may be used after emission of the light from the light source to equalize the intensity and distribution of the radiation over a cross sectional area of a beam of emitted light after it exits the emitter and before it enters the measurement site of the patient.

**[0048]** The detector 260 of the brain oxygenation sensor 300 may be any suitable device for detecting radiation including any combination of various photodiodes including InGas and Si photodiodes. In an embodiment, the detector 260 is a photodiode connected directly to the forehead sensor 120. In another embodiment, the forehead sensor 120 collects light that has passed through patient tissue with a fiber optic cable or other similar apparatus that is positioned at an appropriate measurement site, for example on the patient's forehead. In an embodiment, the fiber optic cable could then transmit the collected light to the detector 260 of the brain oxygenation sensor 300.

**[0049]** The EEG electrodes 440 may be any suitable electrodes for detecting the electro-potentials on the surface of the skin of a patient's head. In one embodiment, EEG electrodes 440 comprise a metal or other suitable conductor and utilize leads contacting the surface of the skin. In another embodiment, the electrodes 440 are gelled electrodes that make contact through the skin via gel and have metal leads that come into contact with the gel. In still yet another embodiment, the EEG electrodes 440 may be glued to the forehead with any suitable patient dermal adhesive for connecting the EEG electrodes 440 and may have electrical conductivity. In an embodiment, potentials from the EEG electrodes 440 are transmitted to the brain oximetry unit 140 for further conditioning, transmitting or processing.

**[0050]** FIGURES 3B and 3C show embodiments of a reusable portion 420 of the sensor 120. In an embodiment, the reusable portion 420 includes the potentially more expensive components, including, for example, the sensor light source(s) 230 and detector(s) 260. The reusable portion 420 may also include the temperature sensor 320. The temperature sensor 320 may be any suitable sensor that can detect the temperature of the surface of the skin or other patient temperatures. In an embodiment, the temperature sensor 320 may include a thermistor associated with the reusable portion 420 of the sensor 120.

**[0051]** In an embodiment, the reusable portion 420 includes an interface 510 that couples the reusable portion 420 of the sensor to the brain oximetry unit 140. The interface 510 may be any suitable electrical or data connection or communication port or device including, for example, a pin connector and receiver. Various other communication or electrical connections known in the art may be utilized. In an embodiment, the interface 510 is an inductance connection utilizing transformers to couple a data and electrical connection across an insulator. In another embodiment, the interface 510 provides a data or electronic coupling between the reusable portion 420 and the disposable portion 410 of the sensor.

**[0052]** [0107] FIGURES 3D - 3O illustrate various embodiments of a disposable portion 410 of a forehead sensor 120 that, in an embodiment, attaches to a measurement site of a patient's head and provides a base 520 to which the reusable portion 420 may be docked, mated or connected. FIGURES 3D - 3E illustrate an embodiment of a single chip disposable portion 410 of the sensor 120. The disposable portion 410 houses the components of the sensor 120 that may be less expensive than at least some of the components contained in the reusable portion 420 of the sensor 120 and therefore may be disposed after a single or multiple uses, either on the same patient or different patients. The disposable portion 410 of the sensor 120 includes a tape substrate 530 that provides a base or substrate to which at least some of the components of the disposable portion 410 may adhere or be integrated. In an embodiment, the tape 530 can be constructed from any suitable disposable material that will effectively hold the components includes in the disposable portion 410 to a patient's forehead or other measurement site. In an embodiment, the tape 530 includes a suitable dermal adhesive on a patient side of the disposable portion 410 for temporary adhesion of the sensor 120 to a patient's skin.

**[0053]** In an embodiment, the disposable portion 410 of the sensor 120 may incorporate various disposable components which may include, EEG electrodes 440. In one embodiment, the EEG electrodes 440 may be fastened to the tape 530 of the disposable portion 410. In an embodiment, the EEG electrodes 440 could be embedded in the tape 530 by any known adhesive. In the sensor arts or any other suitable means for connecting the EEG electrodes 440 that would allow the EEG electrode 440 leads to be exposed on a patient side of tape 530 in an appropriate position to come in close proximity to a measurement site of a patient's skin. In an embodiment, EEG electrodes 440 may be gelled so that the gel contacts the electrodes and a measurement site of a patient's skin to provide an electrical path between the measurement site of the patient's skin and the EEG electrodes 440. In an embodiment, the leads of the EEG electrodes 440 are connected to a single chip by wires or other suitable electrical connections, such as a printed circuit.

**[0054]** Figures 3H, 3I, and 3M, illustrate a temperature sensor 320 associated with the tape of the disposable portion 410 of the sensor 120. In an embodiment, the temperature sensor 320 is a thermistor with the thermistor leads exposed on a patient contacting side of the tape 530, in order to facilitate the contacting of the leads of temperature sensor 320 to a measurement site of a patient's skin. In an embodiment, the temperature sensor 320 is connected to single chip through wires or other suitable electrical connections such as a flexible printed circuit. In an embodiment, the temperature sensor 320 may be located anywhere on the tape 530, the disposable portion 410, or the reusable portion 420 of the sensor. In an embodiment, the leads for the temperature sensor

320 may be near the center of tape 530 or anywhere on the periphery of tape 530.

**[0055]** In an embodiment, the disposable portion 410 of sensor 120 may mate and connect to or overlay the reusable portion 420 of the sensor 120. In an embodiment, the non-patient side of the tape 530 could mate or connect to the reusable portion 420 of the sensor 120 through some suitable adhesive on the tape 530 or some physical connection or mating means. In an embodiment, the disposable portion 410 of the sensor 120 may also contain one or several sensory compartments 540. The sensory compartments 540 may contain a transparent window or a space for the light source 230 or the detectors 260 of the reusable portion 420 of the sensor 120 to emit and detect emitted light through the space or transparent window.

**[0056]** In one embodiment, the light source(s) 230 and detector(s) 260 of the reusable portion 420 may align with the sensory compartments 540 while the reusable 420 and disposable 410 portions physically connect at places other than the sensory compartments 540 and light sources 230 and detectors 260. In an embodiment, the light sources 230 and detectors 260 of the reusable portion 420 of the sensor 120 may physically snap into or somehow removably mate with the sensory compartments 540 of the disposable portion 410 of the sensor 120. In one embodiment, the windows of the sensory compartments 540 may contain certain filters to optimize the wavelengths intensity, or other characteristics of the light that passes through the windows in the sensory compartments 540.

**[0057]** In still other embodiments, care may be taken to ensure sterilization of the reusable components is more straightforward, such as, for example, implementing suitable electrical connections through magnetic, optical or other coupling mechanisms that can be mostly or entirely housed in separate housings that are easily sterilized and mostly void of cavities or the like that can trap contamination.

**[0058]** FIGURES 3A, and 3N show an embodiment with the disposable portion 410 of the sensor electrically connected directly to the reusable portion 420 of the sensor 120 through an interface 510. In an embodiment, the interface 510 may be any suitable electrical connection such as a pin connector, a snap in lead connector, an optical connection or an inductance connection.

**[0059]** FIGURES 3H and 3N show an embodiment of the sensor 120 with a pulse oximeter sensor 310 associated with the sensor 120. The pulse oximeter sensor 310 shown in FIGURES 3H and 3N is an ear pulse oximeter sensor 310 that emits and detects radiation to determine the oxygenation of the blood travelling through the arteries of the ear. Many suitable ear pulse oximeter sensors 310 are known in the art such as those sensors commercially available from Masimo Corporation and disclosed herein with reference to U.S. Patent No. 7,341,599. In another embodiment, the pulse oximeter sensor 310 may be a forehead pulse oximeter sensor

310 or any other suitable pulse oximeter known in the art or disclosed herein. The pulse oximeter sensor 310 may be connected to the sensor through electrical wires, wirelessly or other suitable electrical or data connection. Data collected from the pulse oximeter sensor 310 may be transmitted to the brain oximetry unit 140 or pulse oximeter 150 or both for conditioning, or processing.

**[0060]** FIGURE 3G illustrates a multi chip embodiment of the disposable portion 410 of the sensor. In an embodiment, the various EEG electrodes 440 each connect to a separate chip that transmits the detected signal to the interface 510. In an embodiment, the chip transmits the signal to various inductors integrated into interface 510 which transmit the signal to inductors integrated into the reusable portion of the interface 510.

**[0061]** FIGURES 3A, and 3N - 3O show the reusable portion 420 of the sensor 120 associated with or physically mated with the disposable portion 410 of the sensor 120. In an embodiment, the reusable 420 and disposable portions 410 of the sensor 120 physically mate at mating sections on the disposable 410 and reusable 420 portions. In one embodiment, the mating sections are located near the light source 230 and detectors 260 on the reusable portion 420 and the sensory compartments 540 on the disposable portion 410. In an embodiment, the mating sections have rims 550 into which cerebral oximeter 300 emitters 230 and detectors 260 may be placed, snapped into or mated. Rims 550 may be any suitable plastic or other flexible material, including metal that would allow the emitter 230 and detector 260 to press or squeeze fit into place. This would allow the rims to physically hold the emitters 230 and detectors 260 in the proper orientation.

**[0062]** FIGURES 4A - 4O illustrate various embodiments of a light source 230 that may be utilized in a cerebral oximeter sensor 300. FIGURE 4A shows an embodiment of the light source 230 which includes a substrate 610, guide walls 620, a dividing wall(s) 630, a cap 640, reflective portions 650 on the cap, a splitting mirror 660, and an aperture 670. In an embodiment, the light source 230 includes a substrate 610 to provide a base to associate or attach the remaining components. In an embodiment, the light source 230 includes at least one or a plurality of emitters 680, guide walls 620 attached to the substrate 610, and a dividing wall 630 rising from the substrate 610.

**[0063]** FIGURE 4B shows a perspective view of the light source 230 substrate 610 without the cap 640 and one of the guide walls 620, a dividing wall 630, four emitters 680, an emission detector 260 and an aperture 670. In an embodiment, the dividing wall 630 prevents light emitted from the emitters 680 from directly contacting the emission detector 260 or directly exiting through the aperture 670. In an embodiment, the aperture 670 and emission detector 260 may be located anywhere on the side of the dividing wall 630 opposite the side associated with the emitters 680. In one embodiment, the detector 260 is close to the dividing wall 630 and the aperture 670 is

spaced further from the dividing wall 630 than emission detector 260. The aperture 670 can be any suitable opening, slot, space, or gap in the substrate 610 of the light source 230, in order to allow at least some of the light reflected from the cap 640 or guide walls 620 to pass through the substrate 610 and exit the light source 230. In an embodiment, the aperture 670 may be a transparent section filled with material that may have optical properties, including a filter or the like.

**[0064]** FIGURES 4C and 4E illustrate an embodiment of the light source 230 with the substrate 610, emitters 680, cap 640, the splitting mirror 660, the dividing wall 630, the emission detector 260, the aperture 670 and the polarizer 690 in light path of the light exiting aperture 670. FIGURES 4C and 4E illustrate an example of one possible embodiment of the variety of potential light paths taken by light emitted from the emitters 680. First, the light is emitted from the emitters 680 and subsequently may be reflected or deflected by the cap 640 towards the splitting mirror 660. Next, as the splitting mirror 660 includes many smaller reflective components that are angled in different directions, a light beam hitting the splitting mirror 660, depending on its cross sectional area, may be broken into multiple beams. The reflective components will be angled either to direct some of the light taking a certain path toward the emission detector 260 and some of the light taking a path leading to the aperture 670 and out of the light source 230. In an embodiment, these smaller reflective components of the splitting mirror 660 may be randomly spaced on the angled mirror to provide an even distribution or sampling of emitted light from the various emitters 680 to both the emission detector 260 and the aperture 670. The cap 640 may have a reflective coating or be made of a reflective material in order to reflect light the emitters toward the splitting mirror 660.

**[0065]** In an embodiment, the cap 640 may have a curvature similar to the curvature illustrated in Figures 4A, 4C, 4E - 4G, and 4M and also a similar substrate 610, guide walls 620, splitting mirror 660, aperture 670, and emission detector 260 geometry to direct light emitted from the emitters 680 to the emission detector 260 and the aperture 670. This is accomplished by calculating the various angles and light paths of the curvature of the cap, the various angles of the splitting mirror 660, and the reflective components and the various distances between the various components to maintain optimal light paths as described herein.

**[0066]** FIGURE 4D shows an embodiment of the substrate 620 without the cap 640. In an embodiment, the substrate 610 can be manufactured by etching out depressions in a block of material to create the guide walls 620, the dividing wall 630, and the depressions for the emitter(s) 230, emission detector 260, and aperture 670. The substrate 610 may be made of any suitable material. In one embodiment, the substrate 610 is made from a material that provides an even distribution of temperature such as a ceramic material. FIGURE 4F shows an outside view of the light source 230 with dotted lines representing

the splitting mirror 660 and the aperture 670 associated with the substrate 610 of the light source 230. In an embodiment, the cap 640 includes back guide wall 625 attached to the cap 640, the substrate 610, and the splitting mirror 660.

**[0067]** FIGURES 4G and 4H, and 4I show embodiments of the light source 230 from different perspectives. In an embodiment, the cap 640 is supported at least in part by the guide walls 620 that extend down from the cap 640 to the substrate 610. In an embodiment, the cap 640 is dome shaped. Figure 4I illustrates a light source 260 with eight emitters 680. Also shown is an embodiment of the splitting mirror 660 with several different directing reflecting surfaces positioned in different orientations to angle the light rays either toward the aperture 670 or the emission detector 260. FIGURE 4H shows the splitting mirror 660 as viewed from below the substrate 610. The dotted lines represent the outline of the cap 640, the aperture 670, and the emission detector 260.

**[0068]** FIGURES 4J and 4K illustrate an embodiment of the cap 640 that is divided into different sections, with each section tilted at a predetermined angle to facilitate directing of the light paths from light emitted from the emitter(s) 680 to be directed toward the splitting mirror 660 which would then direct the light to the emission detector 260 or the aperture 670. In an embodiment, the sections of the cap 640 may be arced to form the guide walls 620. Also, the cap 640 may include straight segments that are attached to the guide walls 620. In an embodiment, the splitting mirror 660 may be formed in the cap 640, be the material of the cap 640, be fastened to the cap 640, partially to the cap 640, to the guide walls 620 or to the substrate 610 or any combination thereof.

**[0069]** FIGURE 4K illustrates the aperture 670 in the form of a semi-reflectant splitting mirror 660 that allows some of the light to pass through the mirror 660 and reflects the rest of the light to emission detector 260. In this embodiment, the aperture is behind the splitting mirror 660.

**[0070]** FIGURE 4L illustrates an embodiment of the light source 230 with a splitting mirror 660 that includes both a semi-reflectant component and a completely or more strongly reflective component. In one embodiment, the splitting mirror 660 includes a first semi-reflectant mirror positioned at a first angle that reflects a portion of the emitted light to the emission detector 260 or the aperture 670. The second reflective surface reflects the remaining light toward the aperture 670 or the emission detector 260, and in an embodiment, to the opposite of the two components that the first reflective surface direct the light.

**[0071]** FIGURES 4K - 4M also illustrate electrical connections 710 that power the emitters 680 and receive data from the emission detector 260 and are associated with or printed on the side of the substrate 610 or other components of the light source 260. These electrical connections 710 can be any suitable electrical connection and may be printed on any component of the light source

230 including the inside or outside of the cap 640.

**[0072]** FIGURE 4M illustrates an embodiment with light source 230 that includes a semi-reflectant mirror 660 with the emission detector 260 located behind the semi-reflectant mirror 660. In this embodiment, the emission detector 260 samples light that passes through the semi-reflectant mirror 660 and the aperture 670 emits light that is reflected from the semi-reflectant mirror 660.

**[0073]** FIGURE 4N illustrates an embodiment of the light source 230 where at least a part of the space defined by the cap 640, the substrate 610 and the guide walls 620 are filled with light diffusing material 720. The light diffusing material 720 could be any suitable light diffusing material 720 known in the art including an epoxy or other plastic material, fiber optics, any epoxy mixed with beads or other materials. In an embodiment, the light diffusing material 720 may cause the light emitted from the emitters 680 to become increasingly evenly distributed in the domains of at least range and intensity, as the path length of the light emitted from the emitter(s) 680 increases. In an embodiment, the light diffusing material 720 will more evenly distribute the intensity and range of the light that is incident on the emission detector 260 and the light exiting the light source through the aperture 670.

**[0074]** FIGURE 4O illustrates another embodiment of the light source 230 with emitters 680 on far sides of the substrate 610 and angled towards a semi reflectant mirror 660 attached to the cap 640 or guide walls 620. In this embodiment, when the light is emitted onto the semi-reflectant mirror 660, some of the rays will pass directly through the semi-reflectant mirror 660 and be detected by the emission detector 260. The other rays that do not pass directly through semi-reflectant mirror 660 will be reflected. A portion of the reflected rays that have the appropriate incident angle on the semi-reflectant mirror 660 will exit the light source 230 through the aperture 670 after reflecting off the semi-reflectant mirror 660.

**[0075]** FIGURE 4P illustrates another embodiment of the light source 230 that may not require splitting mirror 660. In this embodiment, light rays are instead directed to the detector 260 and the apertures 670 by the diffusion and scattering of the light through light diffusing material 720. The light diffusing material 720 may be any suitable diffuser for dispersing light throughout the inside of the light source 230 including glass, epoxy fill, glass beads, plastic, and any other diffuser, scatterer, mixer or combination known in the art. The light diffusing material 720 may be filled in around emitters 680 or may be a component in front of or around the emitters 680.

**[0076]** Additionally the cap 640 may reflect light diffused throughout the cavity back towards detector 260. The cap 640 may be reflective or non-reflective. In an embodiment, the cap 640 absorbs light so that the detector 260 senses light that has passed through the diffuser and has not reflected off the cap 260, so that it will be similar in quality, for example, intensity, to the light emitted through the apertures 670. The cap 640 may be made of a suitable metal including, for example, copper

and/or gold. In an embodiment, the cap 640 is relatively straight and does not have a rounded profile in order to reduce the cost and complexity of manufacturing and reduce the bulkiness of the light source 230. This is advantageous as a bulkier, larger sensor will add weight and make the sensor 120 more cumbersome on a patient's forehead.

**[0077]** In this embodiment, the apertures 670 may be directly above the emitters 680 or to the left and right of the emitters 680 so that the emitters will emit light directly outside the aperture 670 and most of the light will not have been reflected off of the cap 640 or other inside surfaces of the light source 230 before exiting the light source 230. This will provide for simpler construction of the light source 230 and other advantages.

**[0078]** The emitters 680 in an embodiment, may be LEDs, or any other suitable light emitting device known in the art. Also, in an embodiment, the temperature sensor 320 will provide feedback for regulating the intensity of the emitters 680 in addition to the information obtained from the detector 260 inside light source 230. The operator, therefore, will be able to maintain and determine an accurate intensity for the emitters 680, leading to more accurate results when processing the signals detected by the detectors 260 of the brain oxygenation sensor 300. In an embodiment, the embodiments disclosed with reference to FIGURE 4 comprise an optical bench whose manufacturing costs are significantly lower than those available to design manufacturers today. Diffusing, scattering, reflecting or mixing material, or combinations thereof, may advantageously be used to integrate emitted light, thereby providing an optical bench from comparatively low cost manufacturing materials.

**[0079]** FIGURE 5 illustrates an embodiment of the calibration curve 730 used to determine the intensity of the light emitted from the light source 230 through the aperture 670. In one embodiment, the intensity 740 of the emitted light is mapped with respect to the output 750 of the emission detector 260 of the light source 230. Measuring the output of emission detector 260 will allow the patient monitoring system 100 to calculate a close approximation of the intensity 740 of light being simultaneously emitted from the light source 230 through the aperture 670.

**[0080]** FIGURE 6 illustrates another embodiment of the patient monitoring system that incorporates that brain oximetry unit 140 into a connector 760 for the sensor 120. This advantageously allows for a streamlined profile and reduced manufacturing costs of the brain oximetry unit 140 and associated wires. In this embodiment, the circuitry for driving the front end and controlling the drive signal of the brain oxygenation sensor 300 may be in the brain oximetry unit 140 which may advantageously be partially or entirely housed by the connector 760, or may advantageously be partially or entirely housed by the pulse oximeter 150 or other multi-parameter patient monitor. Additionally, the circuitry for processing the signals detected by the detectors 260 of brain oxygenation sensor 300 may also be partially or entirely housed by the

connector 760.

**[0081]** In an embodiment, the connector 760 may also house various other components that control and process the signals from various sensors associated with a patient monitoring system 100. For example, the connector 760 may house the circuitry for a blood oxygenation sensor 310 in, for example, an embodiment where the sensor 120 incorporates an ear blood oxygenation sensor or other blood oxygenation sensor 310. In another embodiment, the circuitry for processing, detecting and/or driving the signals for the temperature sensor 320, or EEG sensor 330 may advantageously be incorporated into the sensor connector 760.

**[0082]** Also, the signal processing and conditioning circuitry processor for a patient sedation monitor capable of monitoring the EEG signals of a patient and providing feedback on the depth of sedation or awareness of a patient undergoing anesthesia may be partially or entirely incorporated into the connector. Sedation brain function monitors, including those similar to the SEDLine sedation monitor commercially available from Masimo Corporation of Irvine, CA, and disclosed herein with reference to U.S. Patent No. 6128521, 6301493, 6317627, 6430437, among others assigned to Masimo Corporation. The connector 760 may house the circuit board, with six channels for six detectors and the SEDLine algorithm. In this embodiment, a conventional pulse oximeter may include upgraded programming to recognize the connection of a brain oximetry unit 140, whether separate or housed inside connector 760, and provide communication and power to the unit 140. The unit 140 performs the processing and other functionality for the sensor 120, including storing various algorithms for the associated sensors 120.

**[0083]** Integration of all or the majority of the associated circuitry and processing components of several different patient monitoring sensors 120 in a single connector 760 advantageously provides a caregiver a simple device that can be attached to the patient's forehead or other areas on the patient, to provide minimal discomfort to the patient and minimal amount of wires and connections to cause electrical interference with instruments in the hospital environment. Additionally, the caregiver will need to spend less time hooking various sensors to a patient where each would otherwise require its own associated monitoring station. Furthermore, this integration of sensor 120 processing components allows some of the processing components to have shared functionality and therefore saves considerably on manufacturing costs. For example, memory chips, processors, or other electrical components may be shared by the various sensors in the connector 760.

**[0084]** FIGURES 7 - 13 illustrate various embodiments of the construction of the sensor 120. FIGURES 7A - 7E illustrate an embodiment of the sensor without the EEG sensor 330 incorporated and includes the disposable portion 410, reusable portion 420, interface 510, connector 760, sensor compartments 540, light sources 230 and

detectors 260. The part of the interface 510 on the disposable portion 410 slides into the interface 510 on the reusable portion 420. The interface 510 on the reusable portion 420 may be integrated into the connector 760 or may be separate and located elsewhere on the body of the sensor. In an embodiment, the interface 510 on the disposable portion 410 may slide into the interface 510 on the reusable portion 420 and lock or be somehow be held into place until it needs to be removed.

**[0085]** The interface 510 may include an EEPROM or other memory device from an authorized manufacturer in order to provide quality control. Also, the interface 510 may also include software programming or functionality for determining how many uses it has gone through, how many times it has been used or applied to a patient, or the date of manufacture to determine if it has expired. Also, the interface 510 may include an EEPROM for storing information unique to the electrodes that can be read by the patient monitoring system 100 or pulse oximeter 150. The pulse oximeter 150 or patient monitoring system 100 can then determine how many electrodes are contained on the disposable portion 410, for example, and other information.

**[0086]** FIGURE 7E illustrates the placement of the light sources 230 and the detectors 260 for the brain oxygenation sensor 300. The light source 230 may be at the outer end of the sensor 120 and emits light into the cerebral cavity of a patient. The two detectors 260 closest to each light source 230 detect light emitted from the light source 230. For example, the right side light source 230 emits light into the head of a patient and some of the light is returned to the detector 260 closest to the light source 230 and some returns to the detector that is just to the right of the center of the sensor 120. The path that the light travels through the head of a patient to the closer detector generally does not enter the cerebral cavity and travels as deep as the skull. The light path taken by light detected by the further detector 260 generally enters the cerebral cavity. In an embodiment, the signal from the first detector 260 can be subtracted from the second detector 260 in order to provide the information necessary to calculate the cerebral oxygenation as disclosed herein.

**[0087]** FIGURES 8A - 8D illustrate an embodiment of the sensor 120 with the EEG sensor 330 integrated into the sensor 120. In this embodiment, the disposable portion includes the EEG electrodes 440, which are electrically connected to the connector 760 through wires integrated into the body of the disposable portion 410. In another embodiment, the disposable portion 410 includes the EEG electrodes 440 for electrical contact with a patient's skin. In this embodiment, the disposable portion may not include any wiring except for electrically connecting the EEG electrodes 440 to the reusable portion 420.

**[0088]** FIGURES 9A - 9E illustrate an embodiment of the reusable portion 420 that allows the reusable portion to be disconnected from connector 760. In other embodiments, the reusable portion 430 may be permanently connected to the connector 760. In an embodiment, the

reusable portion 420 may be more difficult to disconnect from connector 760 than the disposable portion 410, and may require the operator to open or disassemble at least a part of connector 760.

**[0089]** FIGURE 9E illustrates an embodiment of the reusable portion 420 with light sources 230 and detectors 260 some or all of which may take advantage of several features to allow light piping. In an embodiment, the detectors 260 and light sources 230 may have a raised lip 800 that contacts the skin to create a barrier that prevents light from escaping from the light source 230 or detector 260 to the ambient. In an embodiment, the raised lip 800 may be black and absorbent, or reflective. The light sources 230 and detectors 260 may also have a valley or depression on the glass or other transparent or near transparent parts that increases in depth towards the middle of the component. This valley or depression will also advantageously assist with light piping as greater and firmer contact will be made around the edge of the light source 230 or detector 260 allowing less light to escape to the ambient from the light source 230 or emanating from the skin to the detector 230.

**[0090]** FIGURES 10A - 10D illustrate various embodiments of the reusable portion 420 of the sensor 120. In an embodiment, the reusable portion 420 has multiple layers that are overlaid and connected together. In an embodiment, the layers include a top flexible sleeve 810, a flex circuit support 820, a flex circuit 830 and a bottom flexible sleeve 840. In an embodiment, the top and bottom flex circuit sleeves 810, 840, may be bonded together or connected together either at the edges or through other means known in the art with the flex circuit support 820 and flex circuit 830 inside and in-between. The top flexible sleeve 810 may be made of silicone or another suitable material and may be white or another color. The bottom flexible sleeve 840 may be made from silicon or other material and may be black. The flex circuit support 820 may be made from cyrlex, polyester or another suitable material and provides support for flex circuit 830. Flex circuit 830 may include EEPROM(s), the flexible circuit, the light sources 230 and detectors 260 for the brain oxygenation sensor 300 and the interface 510. The bottom sleeve includes recesses 850 for the light sources 230, detectors 260 and temperature sensor 320.

**[0091]** FIGURES 11A - 11E illustrate an embodiment of the connector 760. The connector 760, in this embodiment, includes a housing 860 that houses the components of the connector 760, including for example, printed circuit boards 870 for various functions, such as, for example, SEDLine monitoring, brain oximetry, pulse oximetry, other blood parameter or physiological parameter calculators, combinations of the same or the like.. The connector 760 also includes the interface 510 for the disposable portion 410 and reusable portion 420. The interface 510 in the connector 760 includes a slot 880 for interface 510 on the disposable portion 410.

**[0092]** FIGURES 12A - 12D illustrate an embodiment of the disposable portion 410 that does not include the

components for the EEG sensor 330 but includes the components for the brain oxygenation sensor 300. In this embodiment, the sensor 120 includes the sensory compartments 540 and the interface 510 which may include an EEPROM for security. In an embodiment, the disposable portion 410 includes an adhesive layer 890 that includes a layer of adhesive and a base material to attach the adhesive layer to the main body of the disposable portion 410. The adhesive layer 890 includes the adhesive for attaching the sensor 120 to the patient's skin. In an embodiment, where the disposable portion 410 does not have the EEG sensor 330 components, the disposable portion 410 will not contain any wires or any other electrical components allowing it to be inexpensively manufactured.

**[0093]** FIGURES 13A - 13D illustrate an embodiment of the disposable portion 410 that includes the EEG sensor 330 components. In this embodiment, the disposable portion has the EEG electrodes 440 and wiring for the EEG electrodes 440. The EEG electrodes 440 may include pads 900 for contact with the patient's skin. The pads 900 fit into openings 910 in the adhesive layer 890 in order to make direct contact with the skin.

**[0094]** FIGURE 14 illustrates an example of a display 920 that may be utilized for the sensor 120. Shown is the brain oxygenation level (bO<sub>2</sub>), the heart rate, blood oxygenation, and the sedation level from the SEDLine brain function monitor. As other sensors have been described or could be integrated into the sensor 120 additional parameters may be shown on the display 920.

**[0095]** Although the foregoing disclosure has been described in terms of certain preferred embodiments, other embodiments will be apparent to those of ordinary skill in the art from the disclosure herein. Additionally, other combinations, omissions, substitutions and modifications will be apparent to the skilled artisan in view of the disclosure herein. Accordingly, the present disclosure is not intended to be limited by the reaction of the preferred embodiments, but is to be defined by reference to the appended claims.

**Claims**

1. A forehead sensor (120) for monitoring the depth of consciousness of a patient comprising:

a brain oxygenation sensor (300) including:

- a first light source (230) configured to transmit optical radiation into the cerebral cavity of a patient,
- a first detector (260) located on the forehead sensor at a first distance from the first light source, and
- a second detector (260) located on the forehead sensor at a second distance from the first light source, wherein the first distance

- is closer to the first light source than the second distance;
- a second light source (230) configured to transmit optical radiation into the cerebral cavity of a patient,
- a third detector (260) located on the forehead sensor at a first distance from the second light source, and
- a fourth detector (260) located on the forehead sensor at a second distance from the second light source, wherein the first distance is closer to the second light source than the second distance;

an EEG sensor that includes a plurality of EEG electrodes (440) adapted to make contact with the skin of the patient's forehead;

a reusable portion (420) that houses the brain oxygenation sensor; and

a disposable portion (410) that houses the plurality of EEG electrodes (440) and is removably connectable to the reusable portion.

- 2. The forehead sensor of claim 1 further comprising a connector that connects to the disposable portion and the reusable portion and houses circuitry and processing components for the EEG sensor and the brain oxygenation sensor.
- 3. The forehead sensor of claim 2 wherein an interface between the connector and disposable portion allows the disposable portion to be removably attached to the connector.
- 4. The forehead sensor of claim 1 wherein the light source has a lip around the edge.
- 5. The forehead sensor of claim 1 wherein the detector has a lip around the edge.
- 6. The forehead sensor of claim 1 wherein the reusable portion is directly connected to the disposable portion.

**Patentansprüche**

1. Stirnsensor (120) zum Überwachen der Tiefe des Bewusstseins eines Patienten, der aufweist:

einen Gehirnsauerstoffsättigungssensor (300), der aufweist:

- eine erste Lichtquelle (230), die konfiguriert ist, optische Strahlung in den Gehirnhohlraum eines Patienten zu übertragen,
- einen ersten Detektor (260), der am Stirnsensor in einem ersten Abstand von der ers-

- ten Lichtquelle angeordnet ist, und einen zweiten Detektor (260), der am Stirnsensor in einem zweiten Abstand von der ersten Lichtquelle angeordnet ist, wobei der erste Abstand näher zur ersten Lichtquelle als der zweite Abstand ist;
- eine zweite Lichtquelle (230), die konfiguriert ist, optische Strahlung in den Gehirnhohlraum eines Patienten zu übertragen, einen dritten Detektor (260), der am Stirnsensor in einem ersten Abstand von der zweiten Lichtquelle angeordnet ist, und einen vierten Detektor (260), der am Stirnsensor in einem zweiten Abstand von der zweiten Lichtquelle angeordnet ist, wobei der erste Abstand näher zur zweiten Lichtquelle als der zweite Abstand ist;
- einen EEG-Sensor, der mehrere EEG-Elektroden (440) aufweist, die eingerichtet sind, mit der Haut der Stirn des Patienten Kontakt aufzunehmen;
- einen wiederverwendbaren Abschnitt (420), der den Gehirnsauerstoffsättigungssensor beherbergt; und
- einen Einwegabschnitt (410), der die mehreren EEG-Elektroden (440) beherbergt und
- entfernbar mit dem wiederverwendbaren Abschnitt verbindbar ist.
2. Stirnsensor nach Anspruch 1, der ferner einen Verbinder aufweist, der den Einwegabschnitt und den wiederverwendbaren Abschnitt verbindet und Schaltkreise und Verarbeitungskomponenten für den EEG-Sensor und den Gehirnsauerstoffsättigungssensor beherbergt.
  3. Stirnsensor nach Anspruch 2, wobei es eine Schnittstelle zwischen dem Verbinder und dem Einwegabschnitt ermöglicht, dass der Einwegabschnitt entferntbar am Verbinder angebracht wird.
  4. Stirnsensor nach Anspruch 1, wobei die Lichtquelle eine Lippe um die Kante aufweist.
  5. Stirnsensor nach Anspruch 1, wobei der Detektor eine Lippe um die Kante aufweist.
  6. Stirnsensor nach Anspruch 1, wobei der wiederverwendbare Abschnitt direkt mit dem Einwegabschnitt verbunden ist.
- Revendications**
1. Capteur frontal (120) pour surveiller le degré de conscience d'un patient, comprenant :

un capteur d'oxygénation cérébrale (300) comportant :

une première source lumineuse (230) prévue pour émettre un rayonnement optique vers la cavité cérébrale d'un patient, un premier détecteur (260) disposé sur le capteur frontal à une première distance de la première source lumineuse, et un deuxième détecteur (260) disposé sur le capteur frontal à une deuxième distance de la première source lumineuse, la première distance étant plus proche de la première source lumineuse que la deuxième distance ;

une deuxième source lumineuse (230) prévue pour émettre un rayonnement optique vers la cavité cérébrale d'un patient, un troisième détecteur (260) disposé sur le capteur frontal à une première distance de la deuxième source lumineuse, et un quatrième détecteur (260) disposé sur le capteur frontal à une deuxième distance de la deuxième source lumineuse, la première distance étant plus proche de la deuxième source lumineuse que la deuxième distance ;

un capteur EEG présentant une pluralité d'électrodes EEG (440) adaptées pour être en contact avec la peau du front du patient ; une partie réutilisable (420) où est logé le capteur d'oxygénation cérébrale ; et une partie jetable (410) où sont logées les plusieurs électrodes EEG (440) et qui peut être raccordée de manière amovible à la partie réutilisable.

2. Capteur frontal selon la revendication 1, comprenant en outre un connecteur raccordé à la partie jetable et à la partie réutilisable et où sont logés les circuits et les composants de traitement pour le capteur EEG et le capteur d'oxygénation cérébrale.
3. Capteur frontal selon la revendication 2, où une interface entre le connecteur et la partie jetable permet à la partie jetable d'être fixée de manière amovible au connecteur.
4. Capteur frontal selon la revendication 1, où la source lumineuse présente une lèvre autour du bord.
5. Capteur frontal selon la revendication 1, où le détecteur présente une lèvre autour du bord.
6. Capteur frontal selon la revendication 1, où la partie réutilisable est directement raccordée à la partie jetable.

FIG. 1A

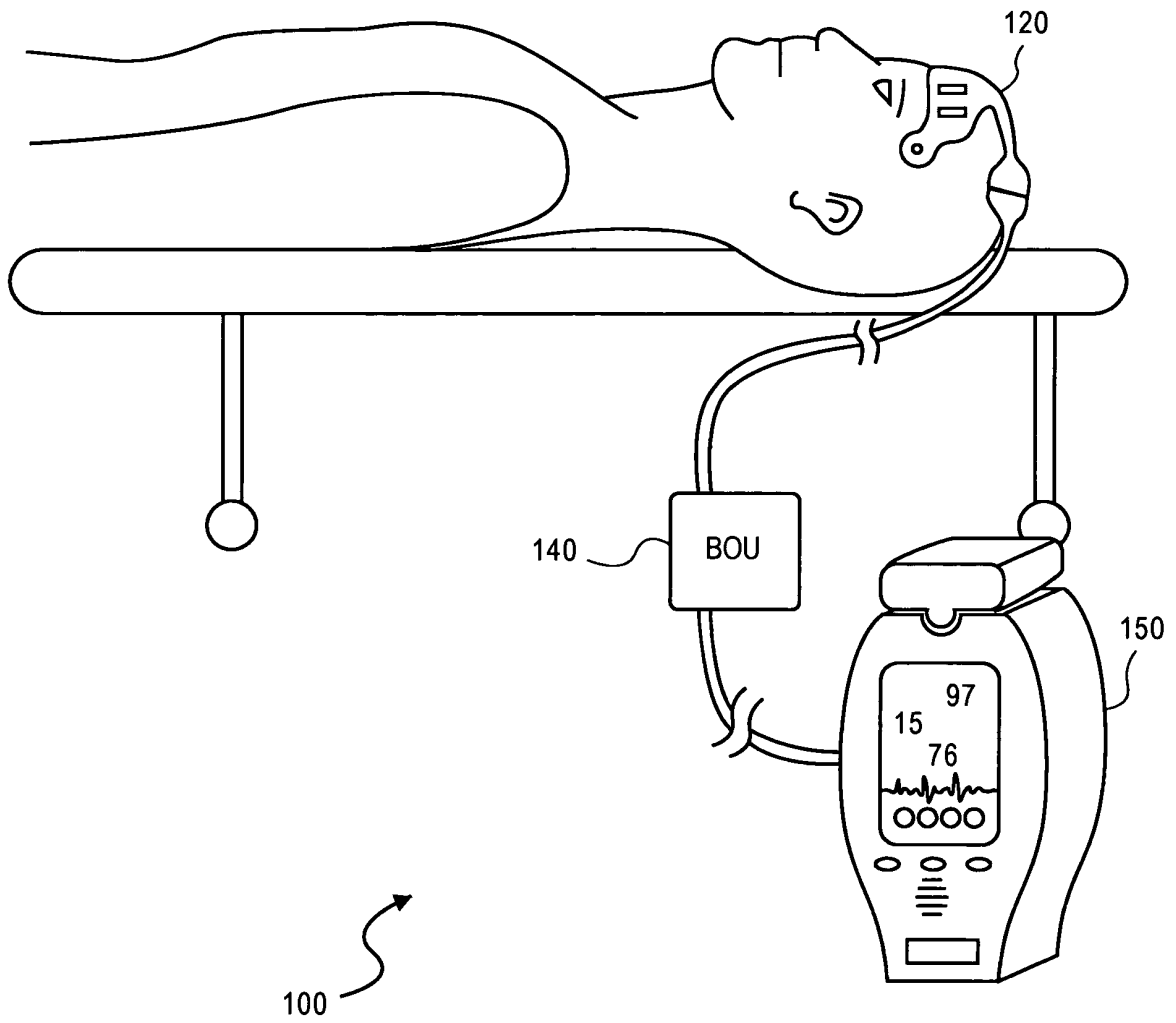
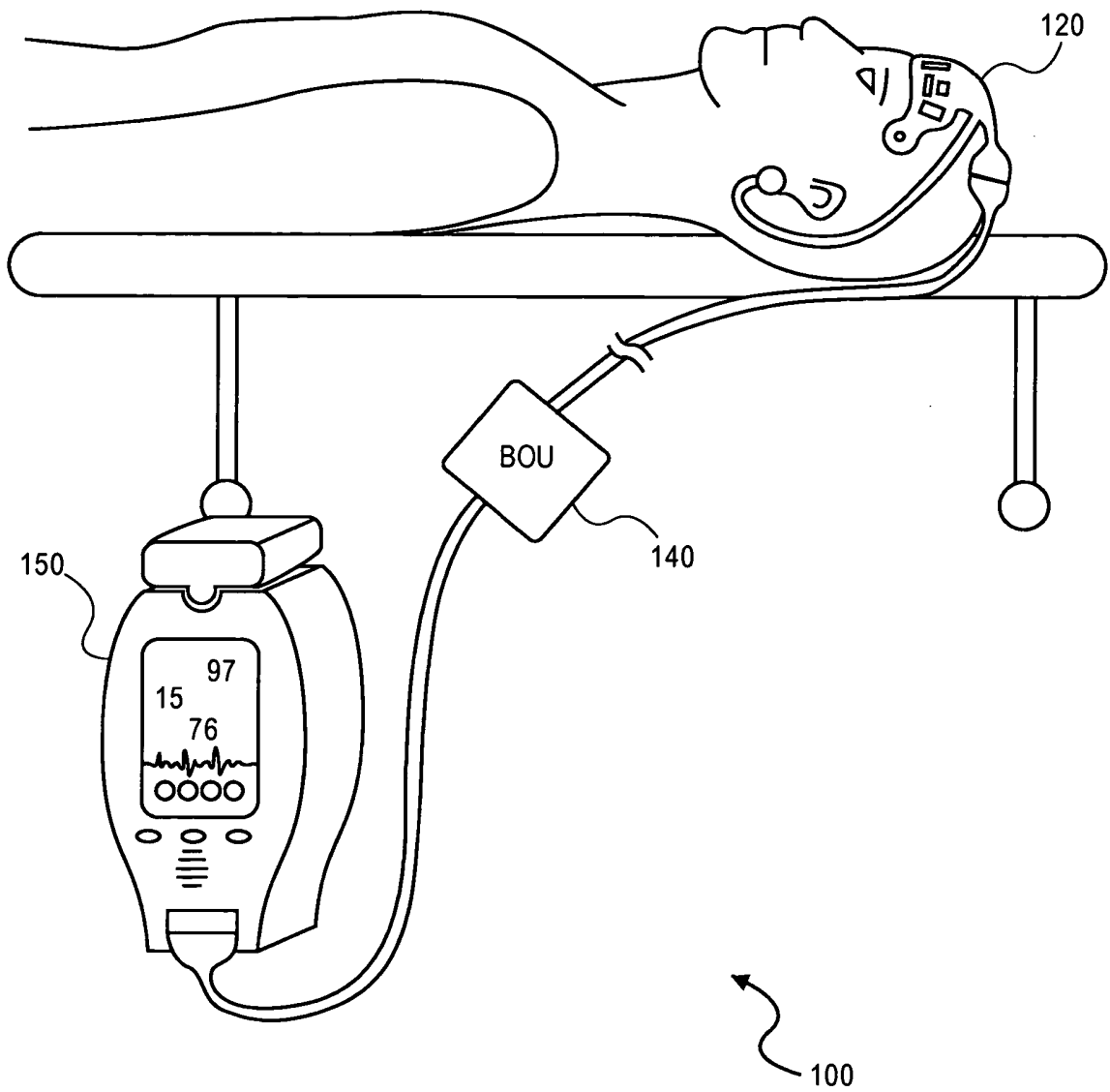


FIG. 1B



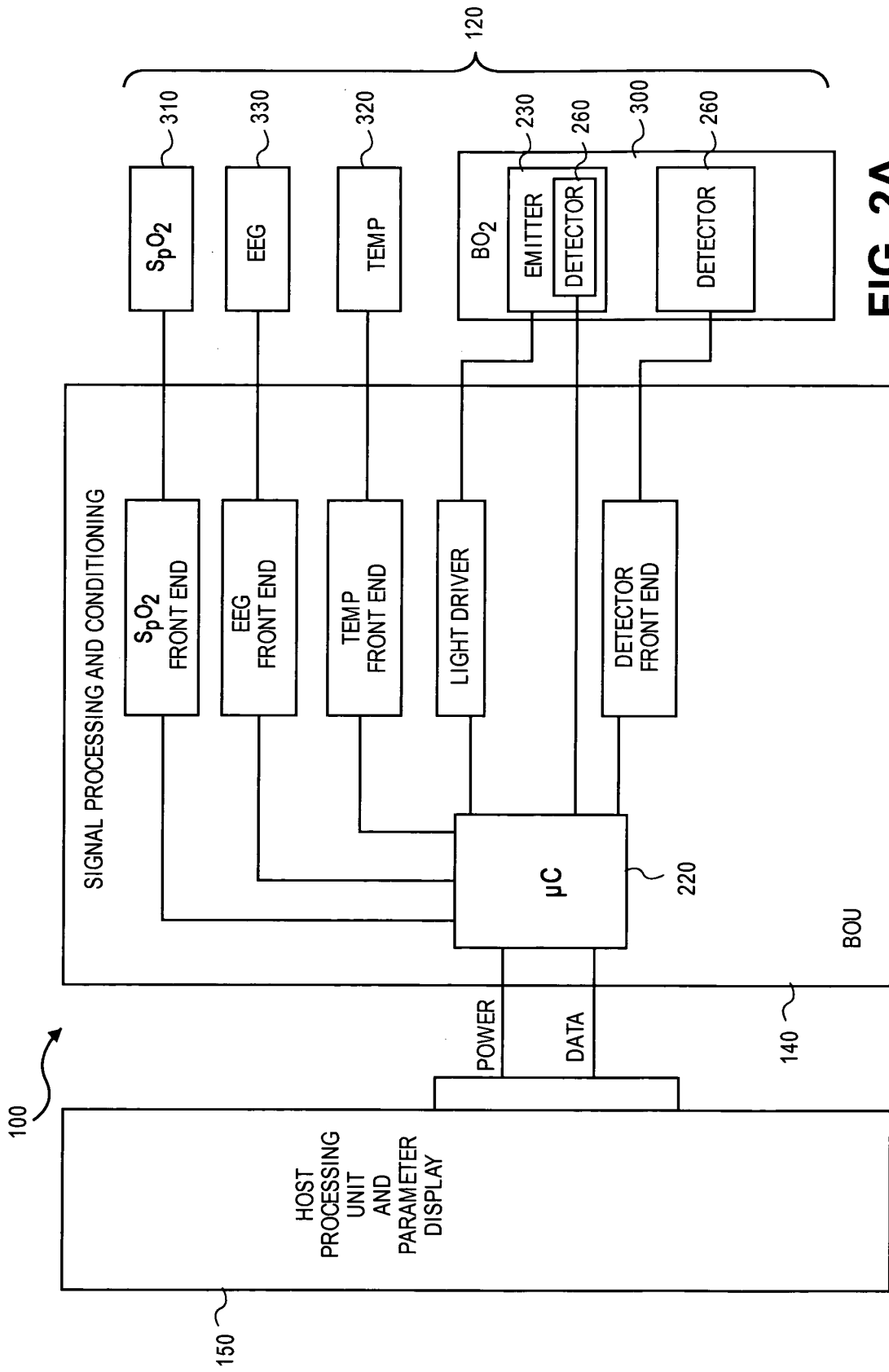
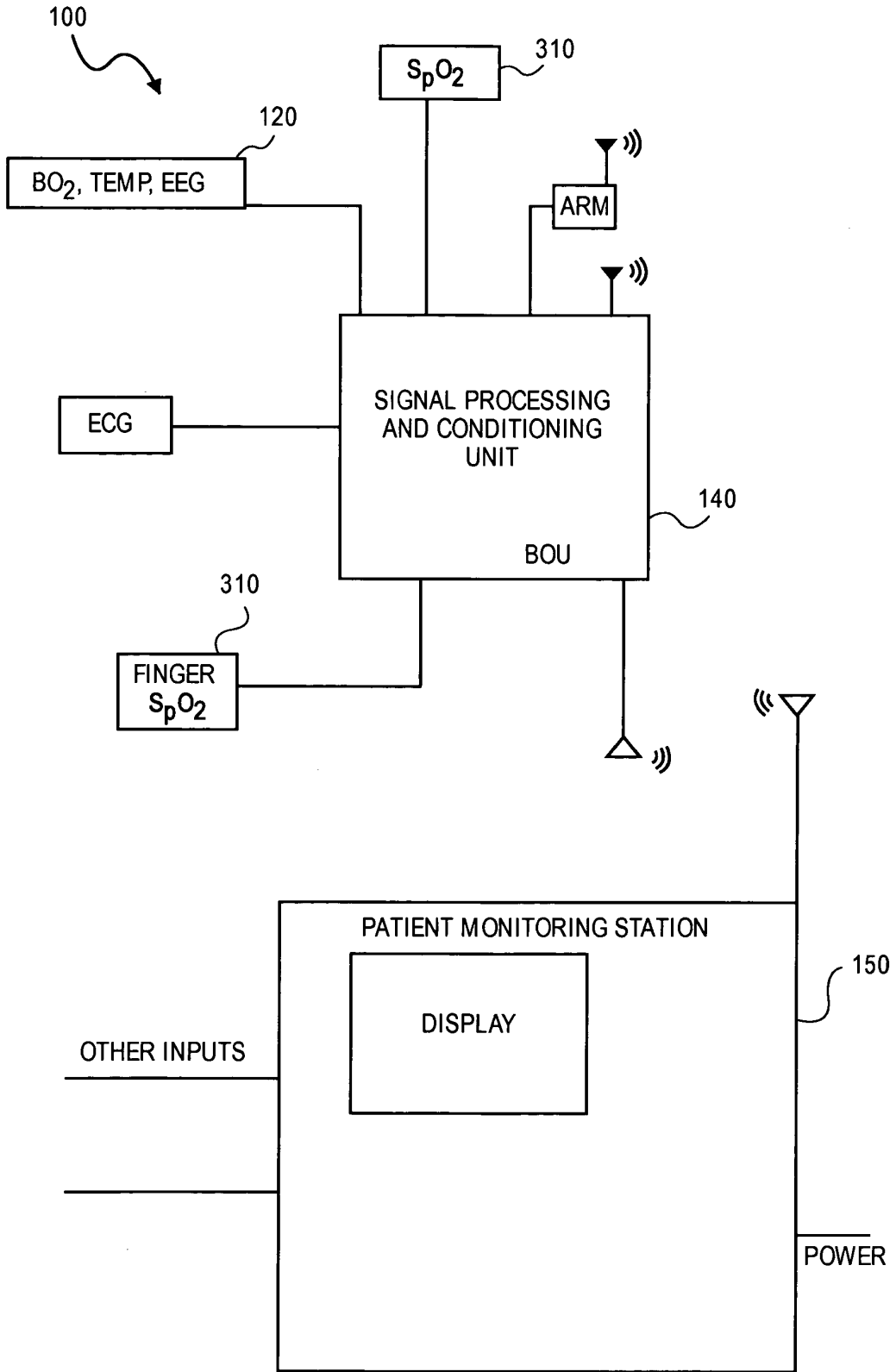


FIG. 2A



**FIG. 2B**

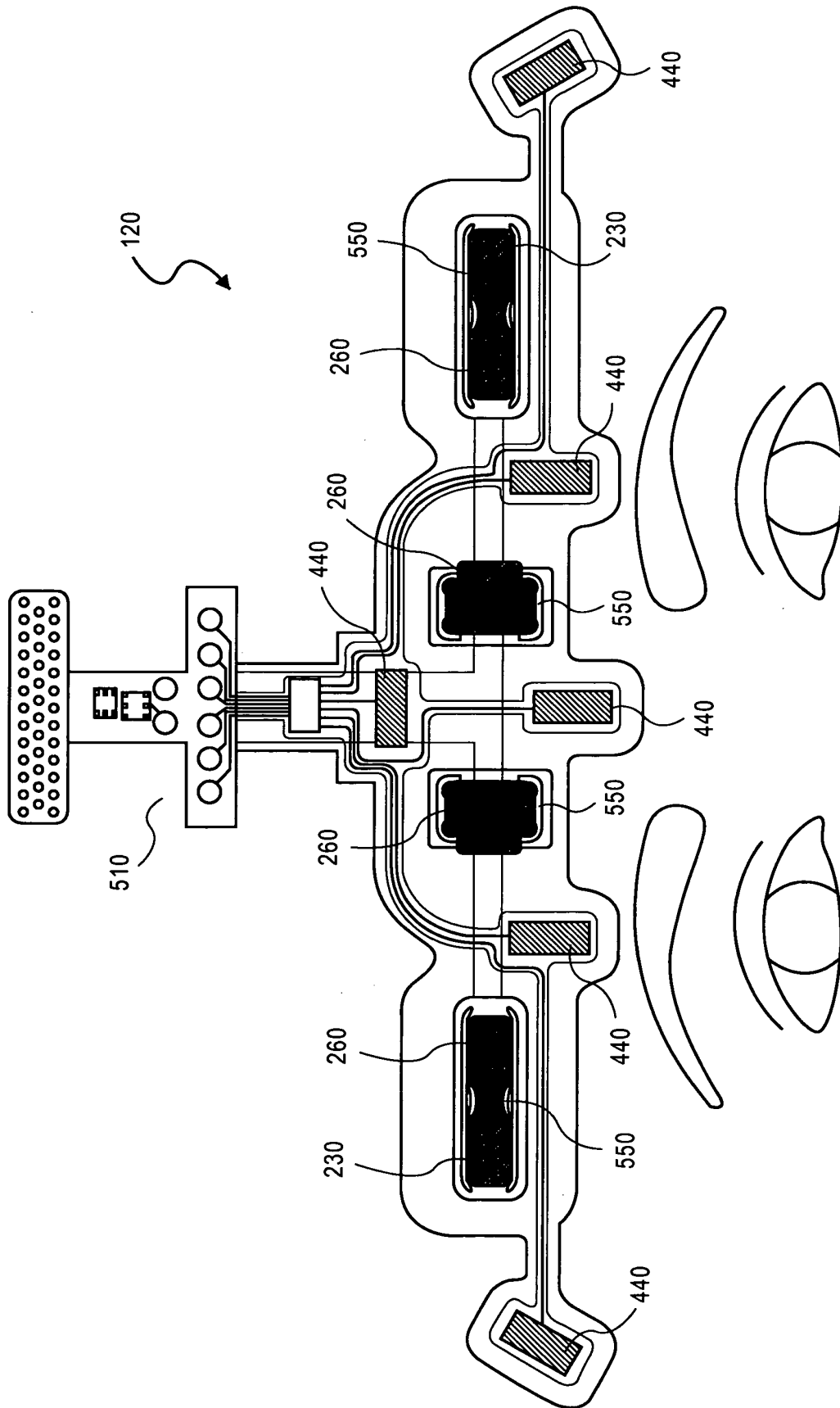


FIG. 3A

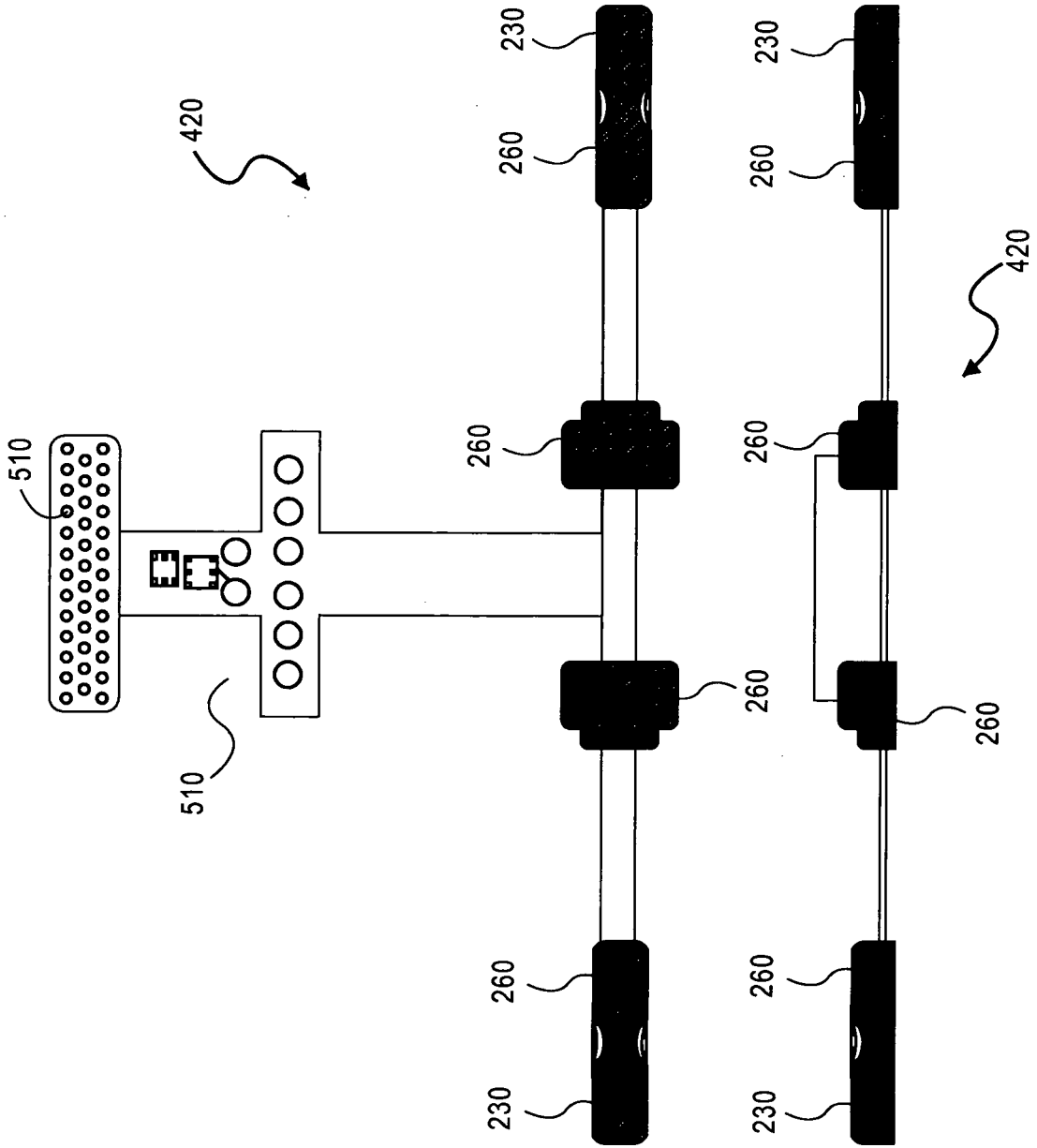


FIG. 3B

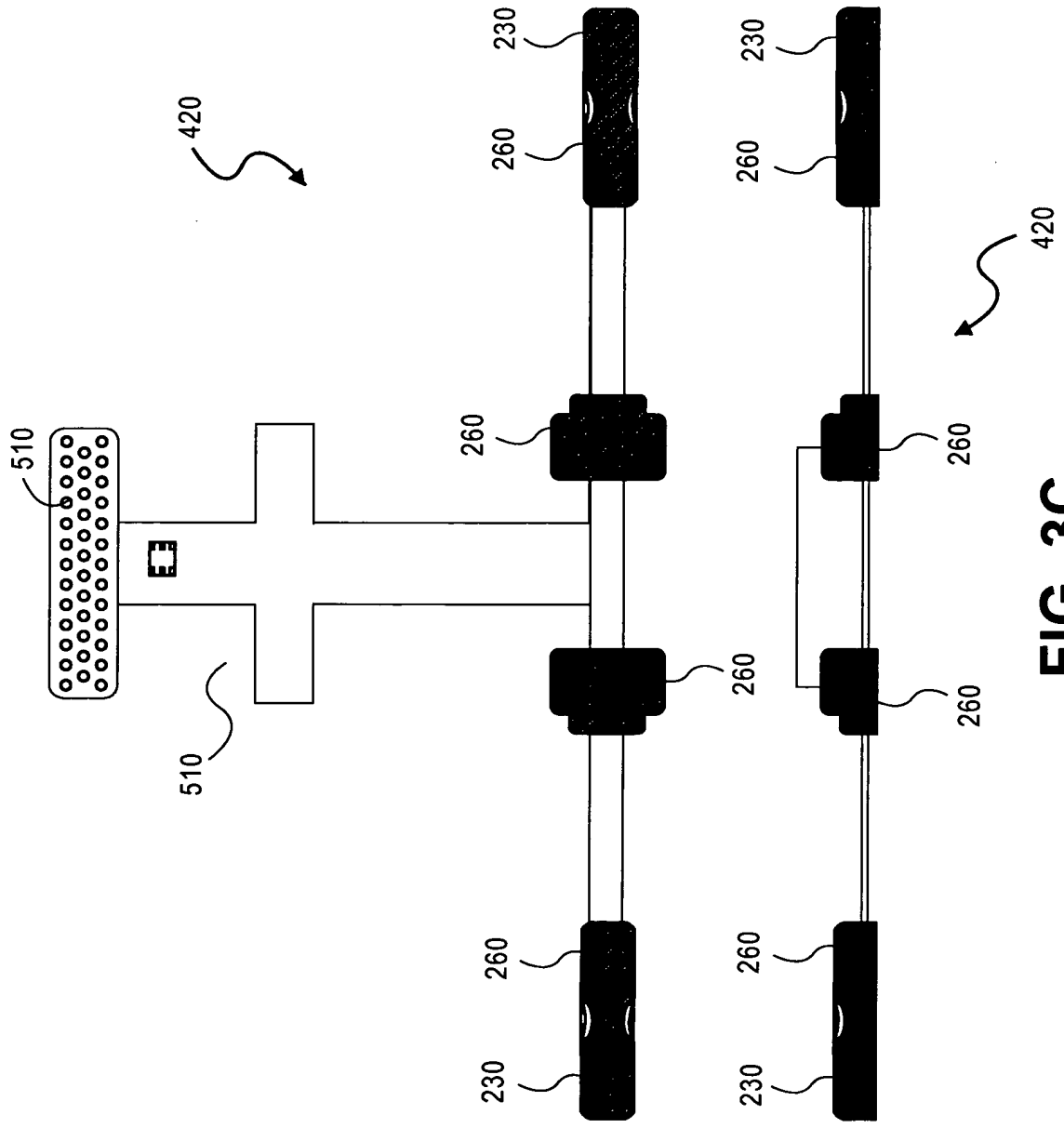


FIG. 3C

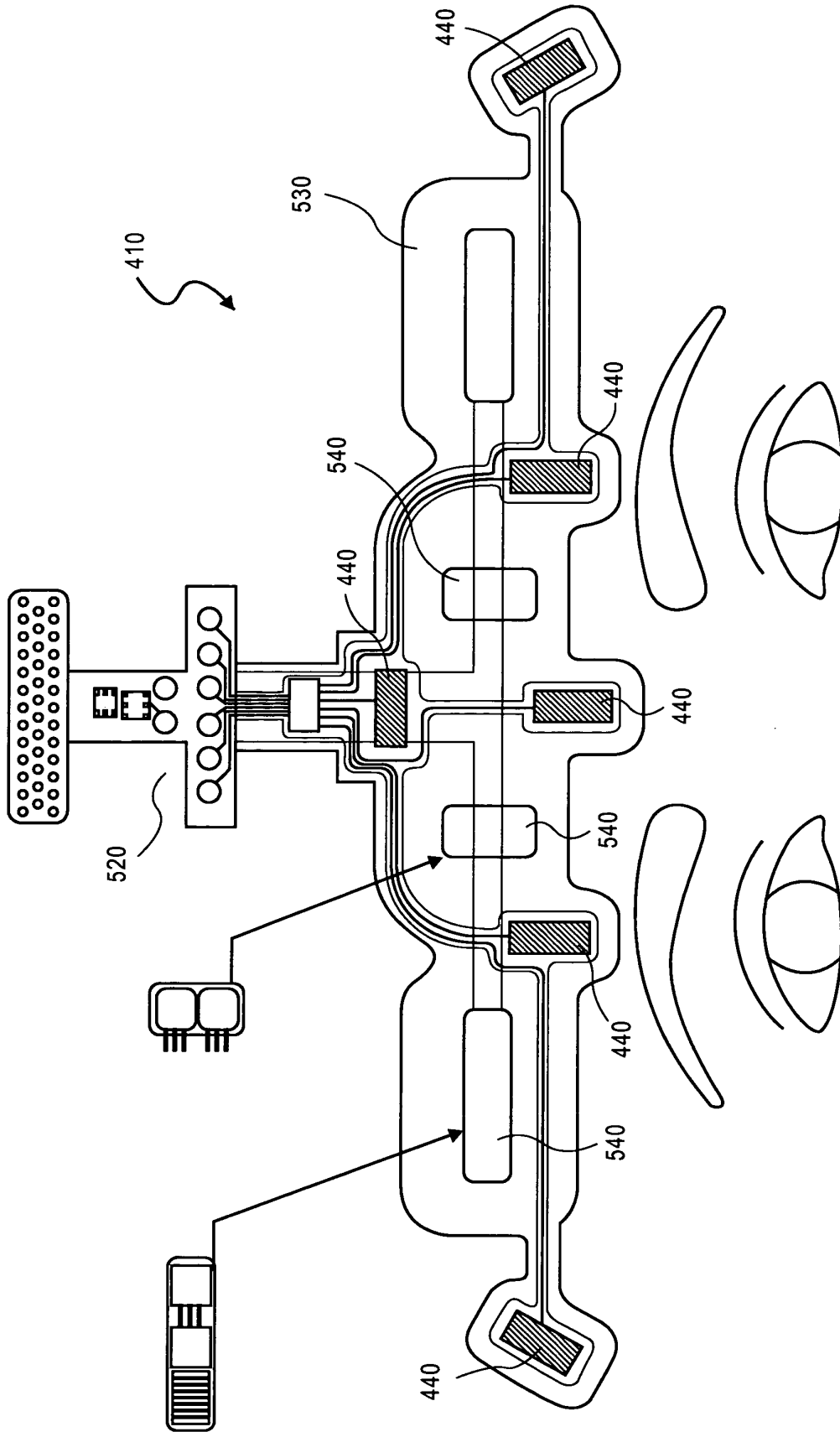
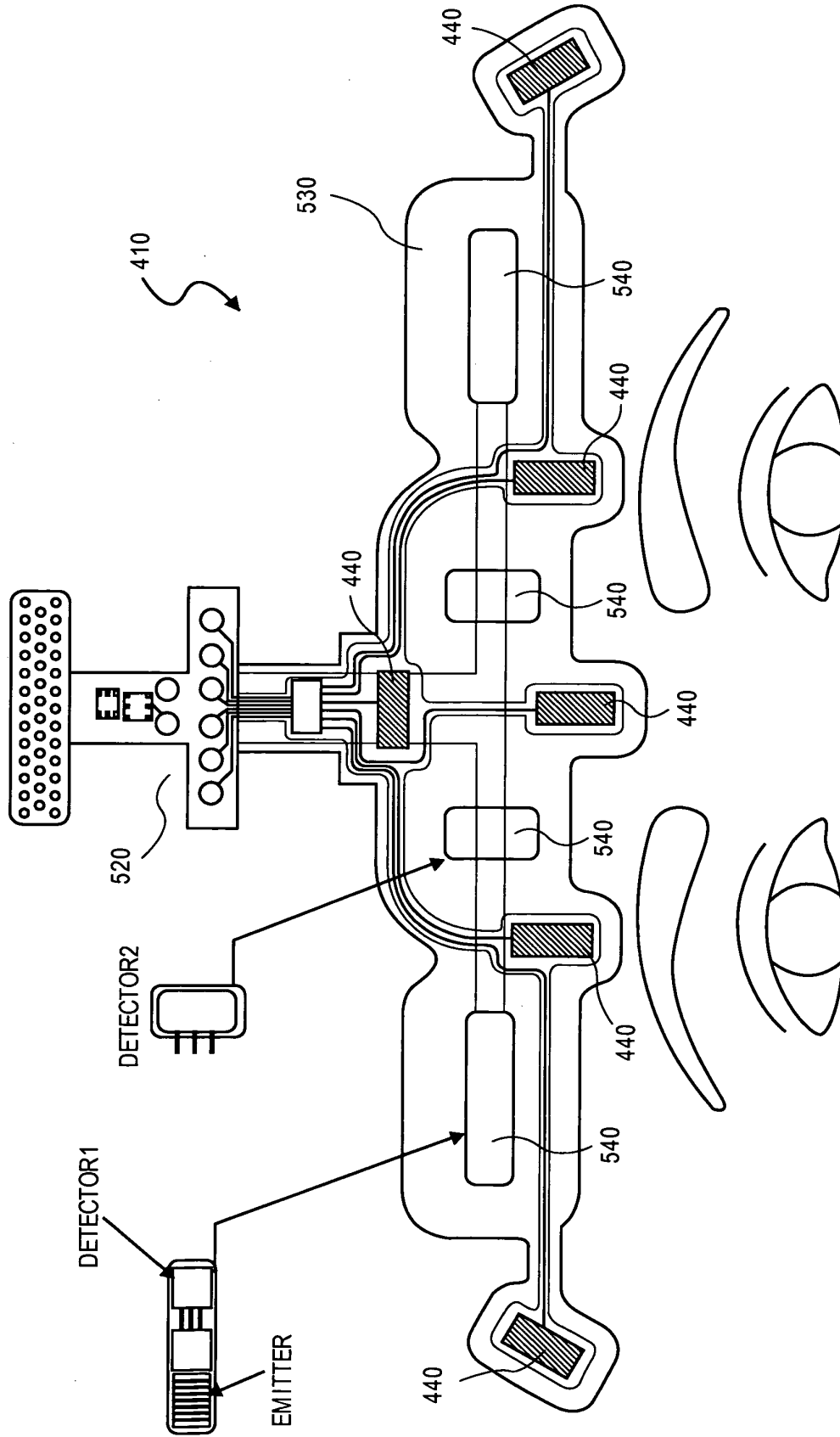


FIG. 3D



**FIG. 3E**

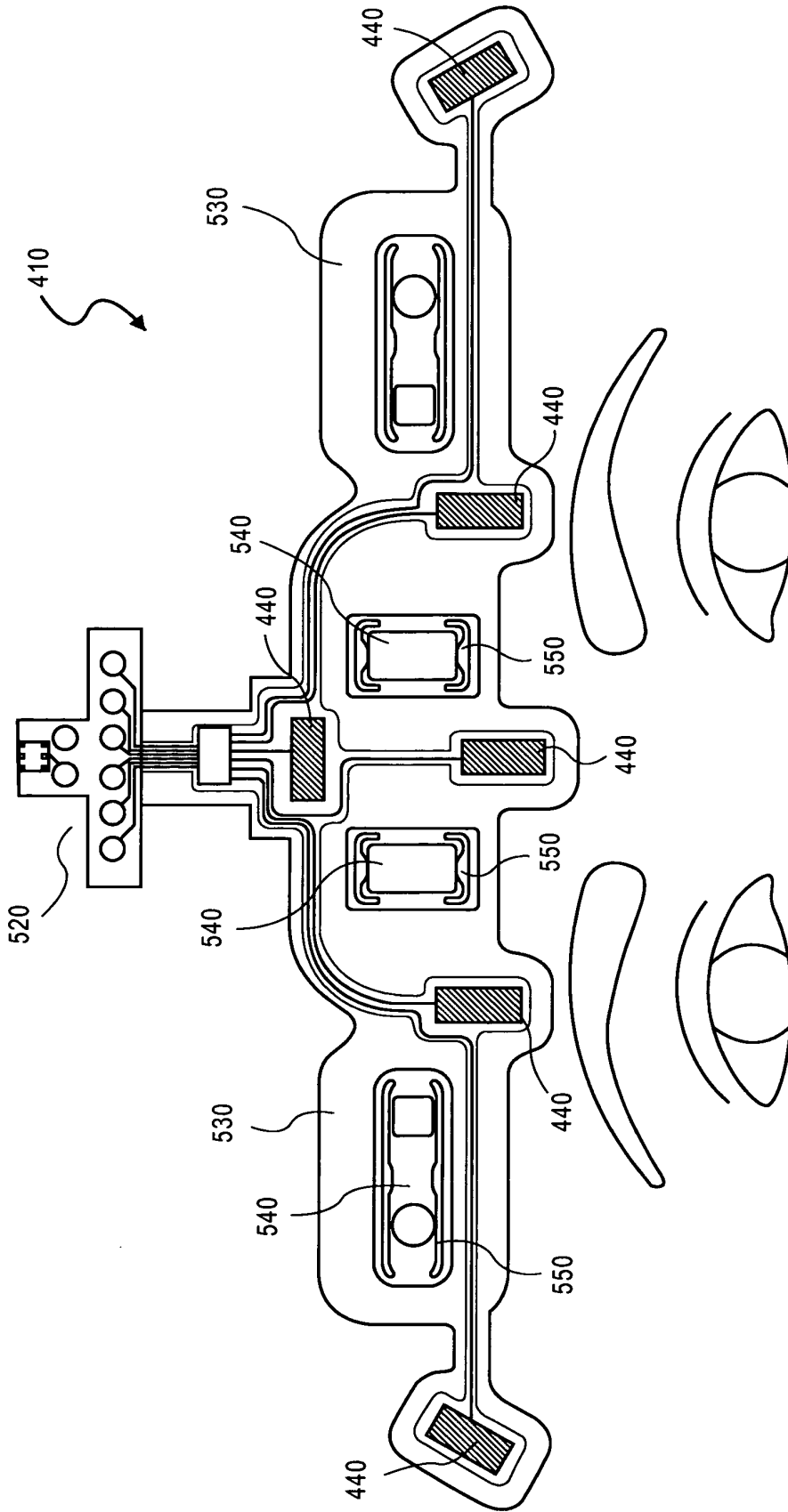


FIG. 3F

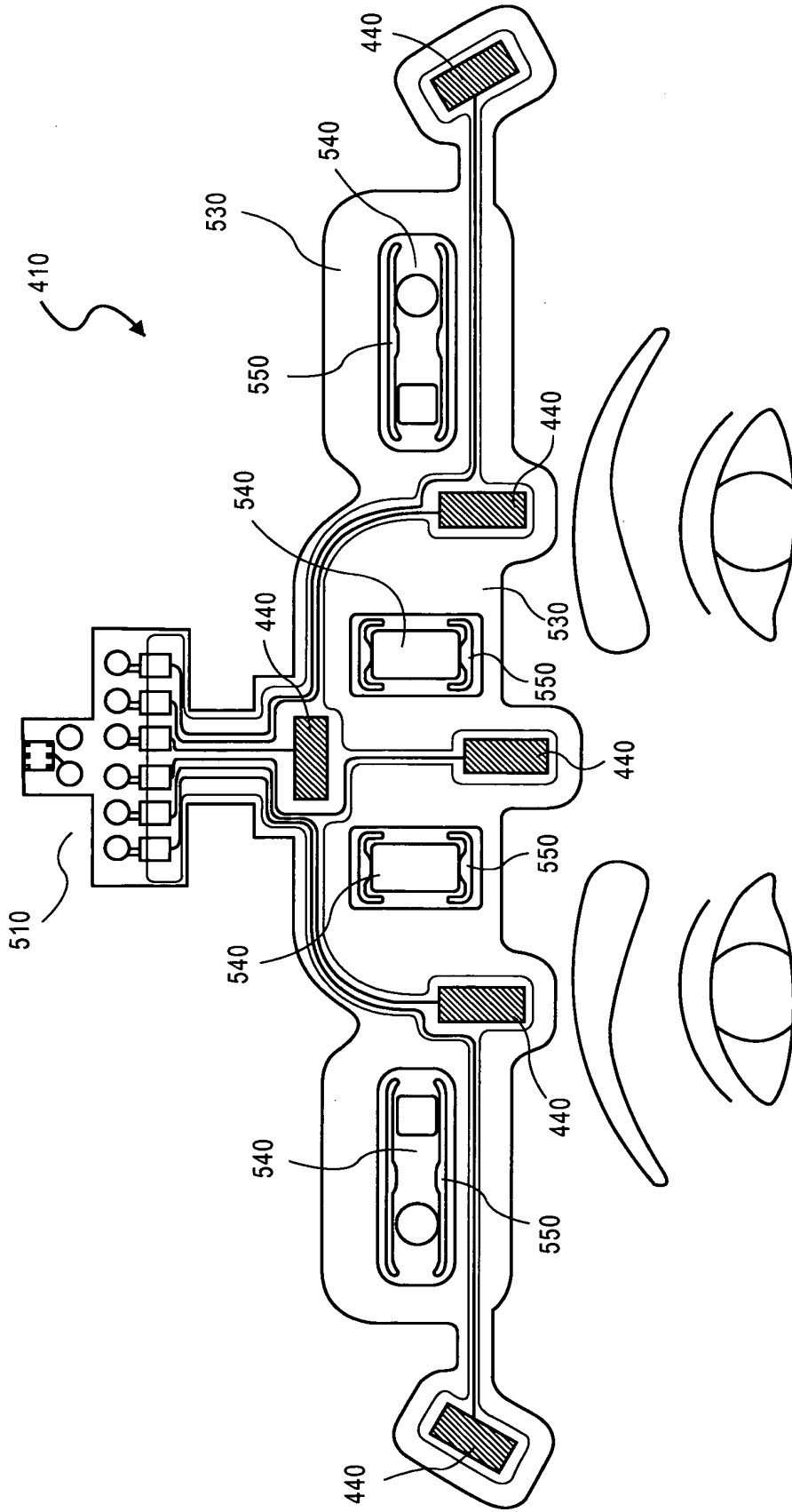


FIG. 3G

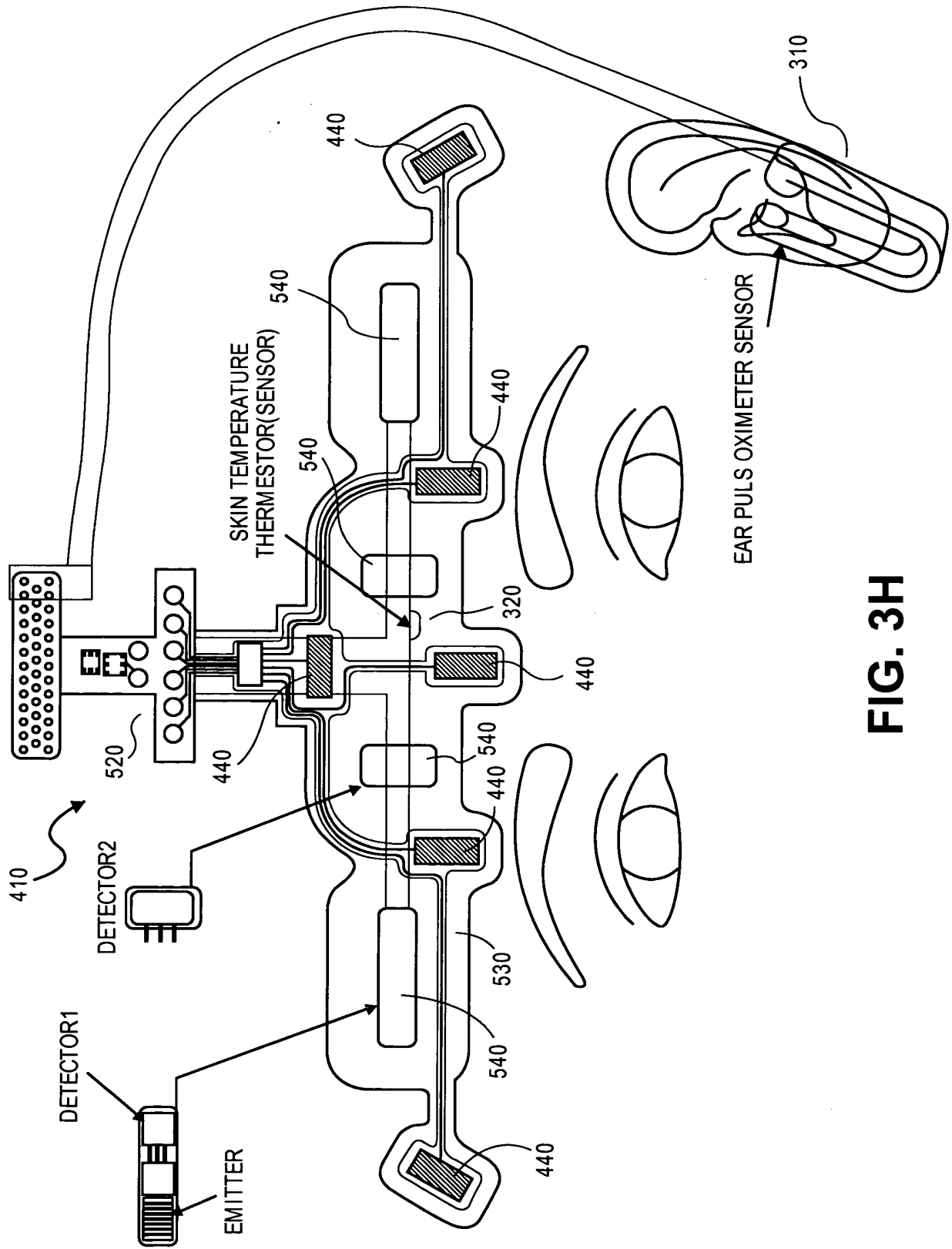
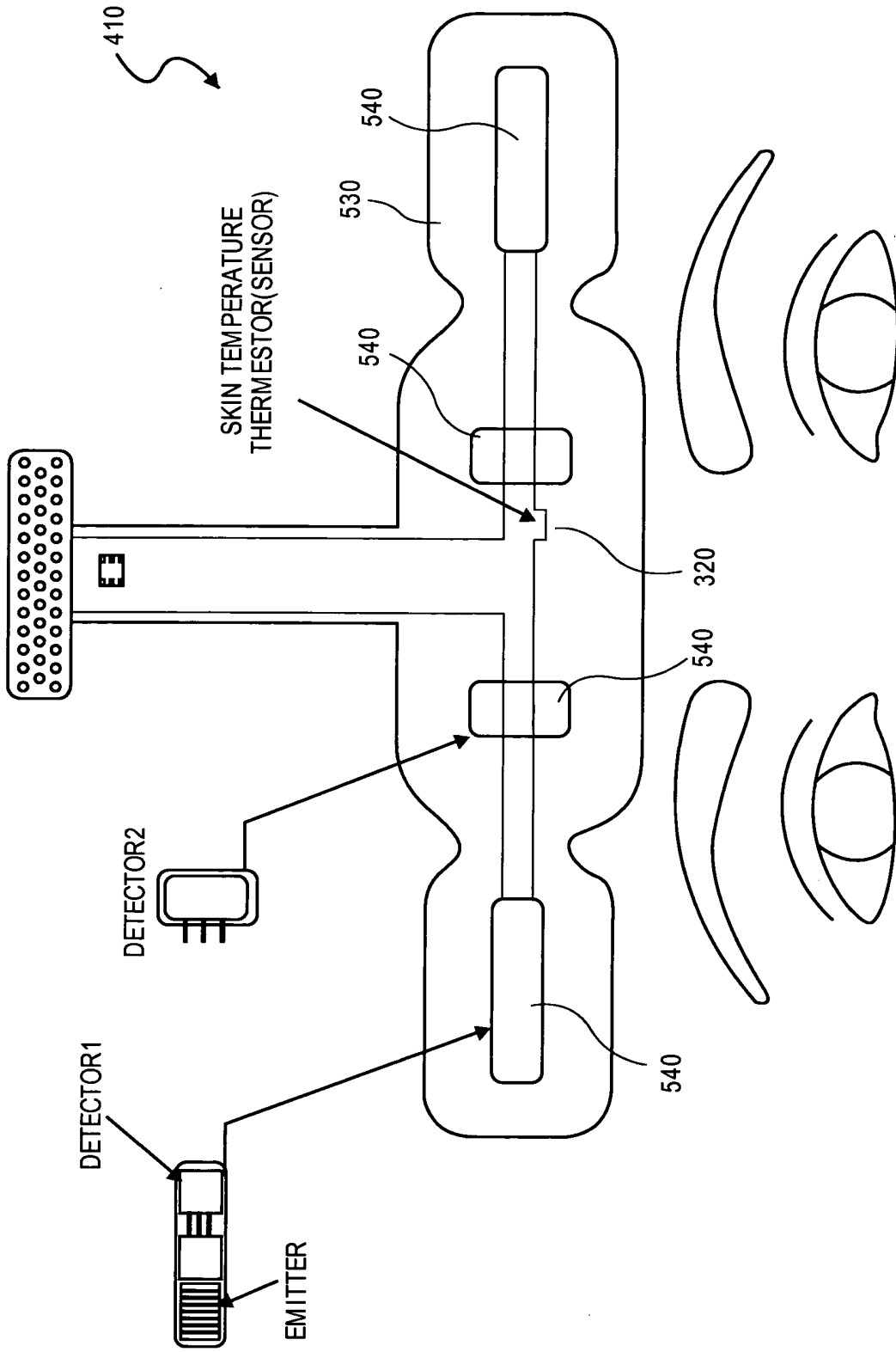


FIG. 3H



**FIG. 3I**

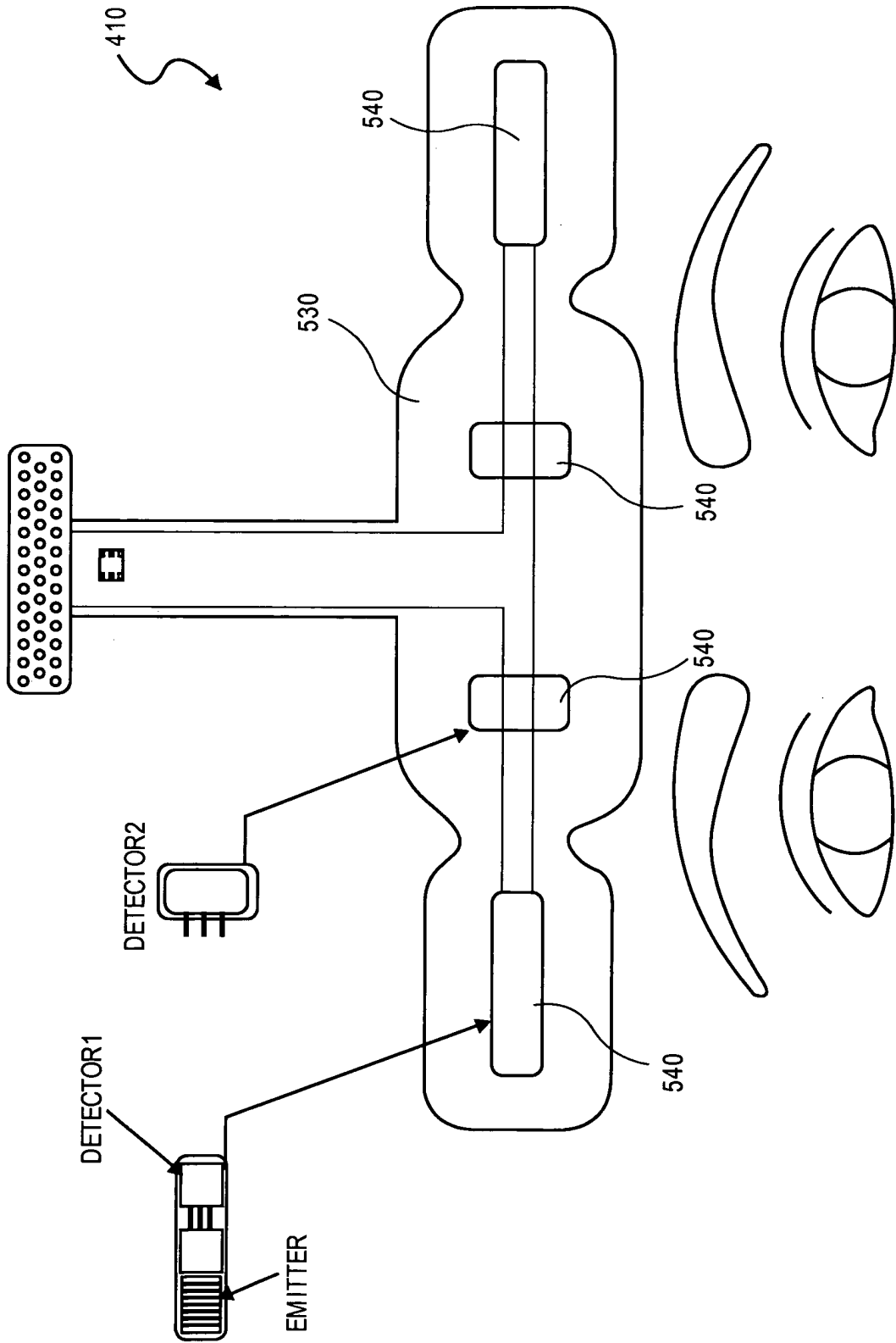


FIG. 3J

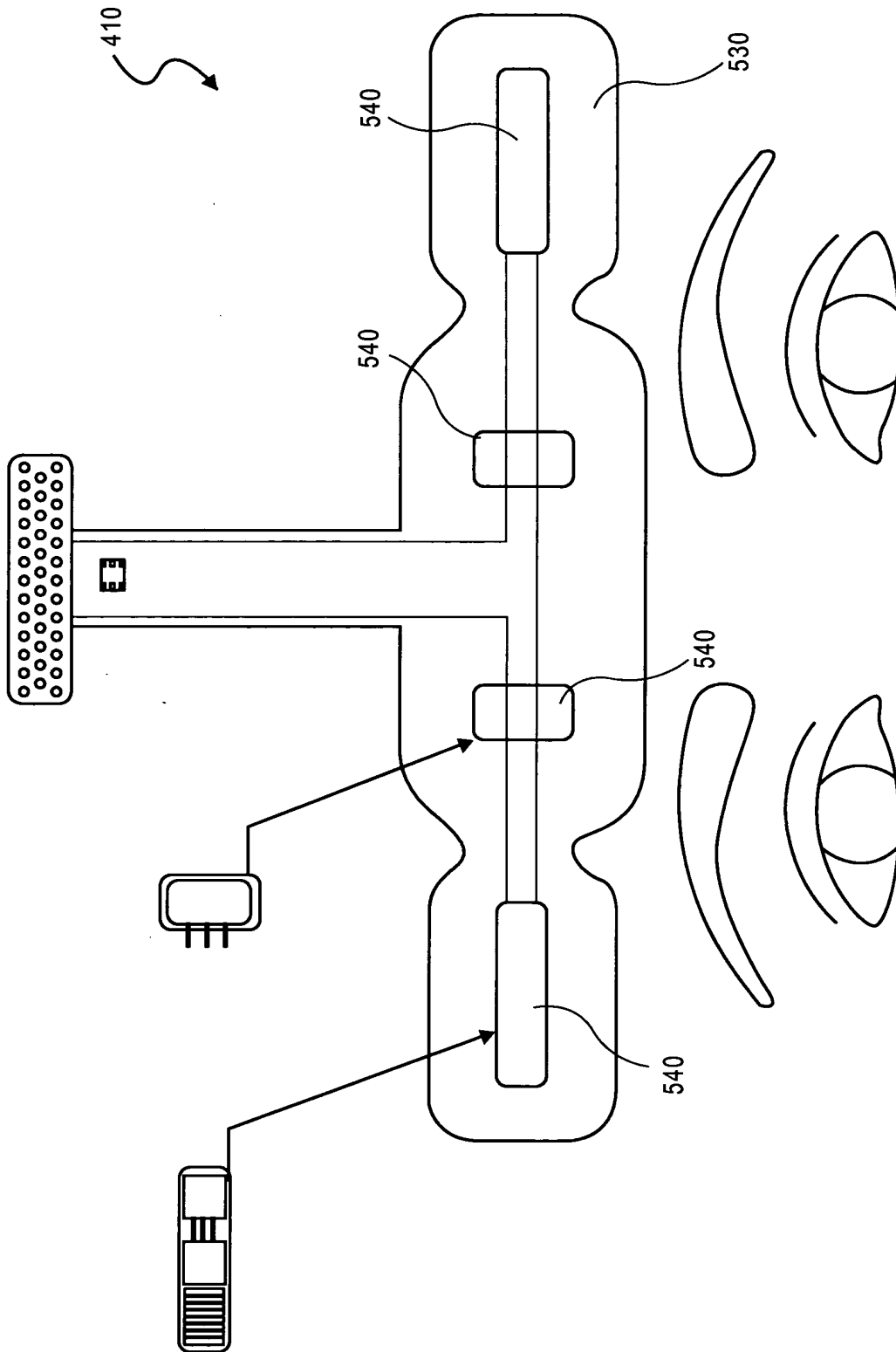


FIG. 3K

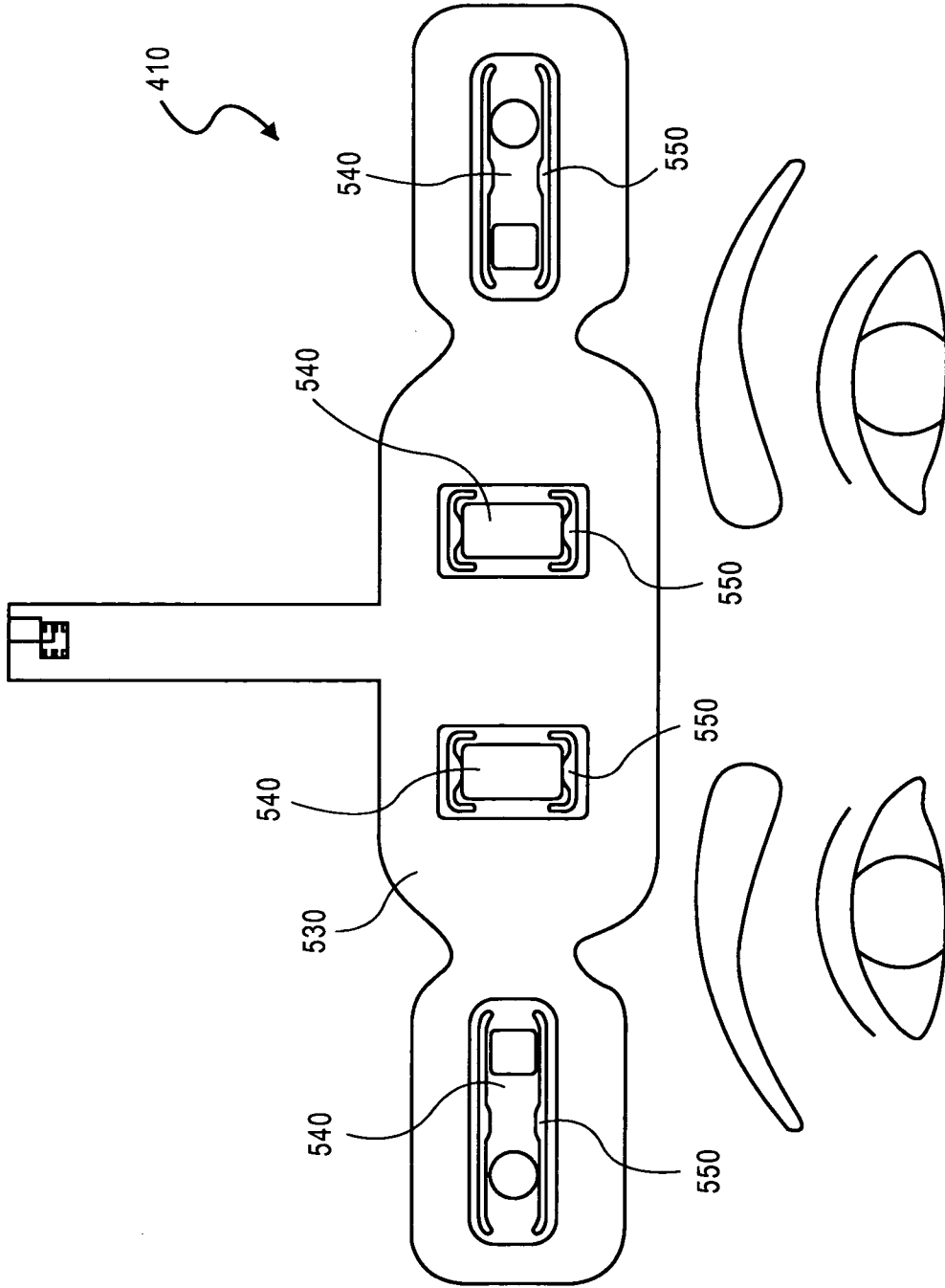
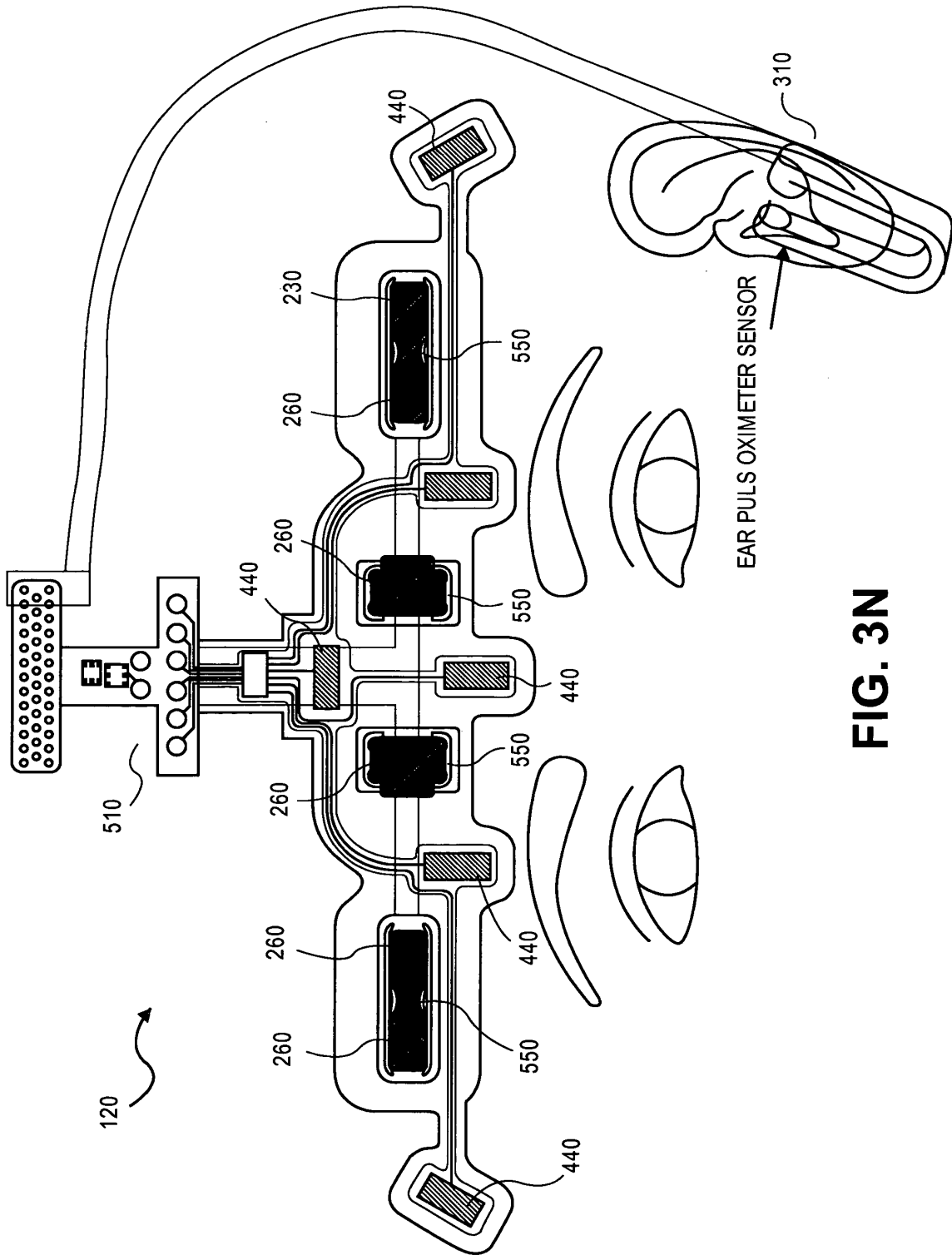


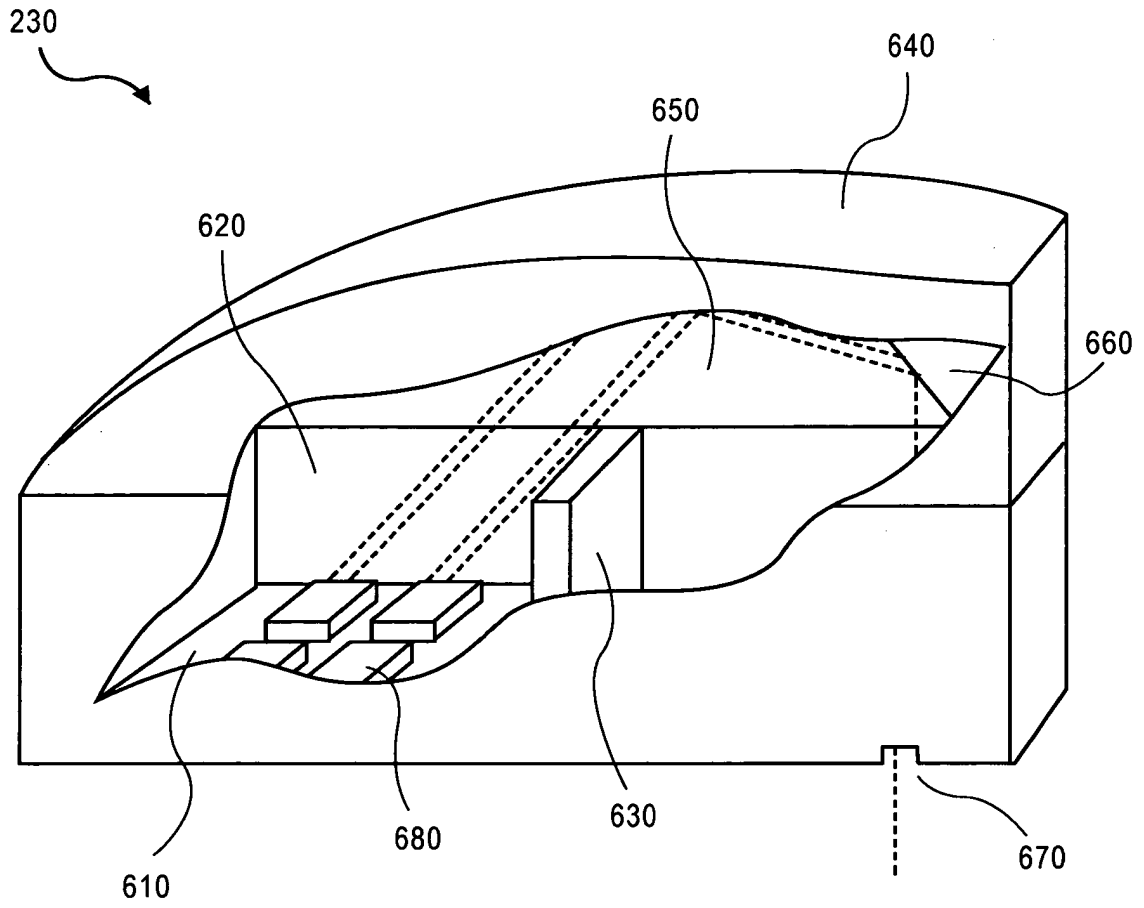
FIG. 3L



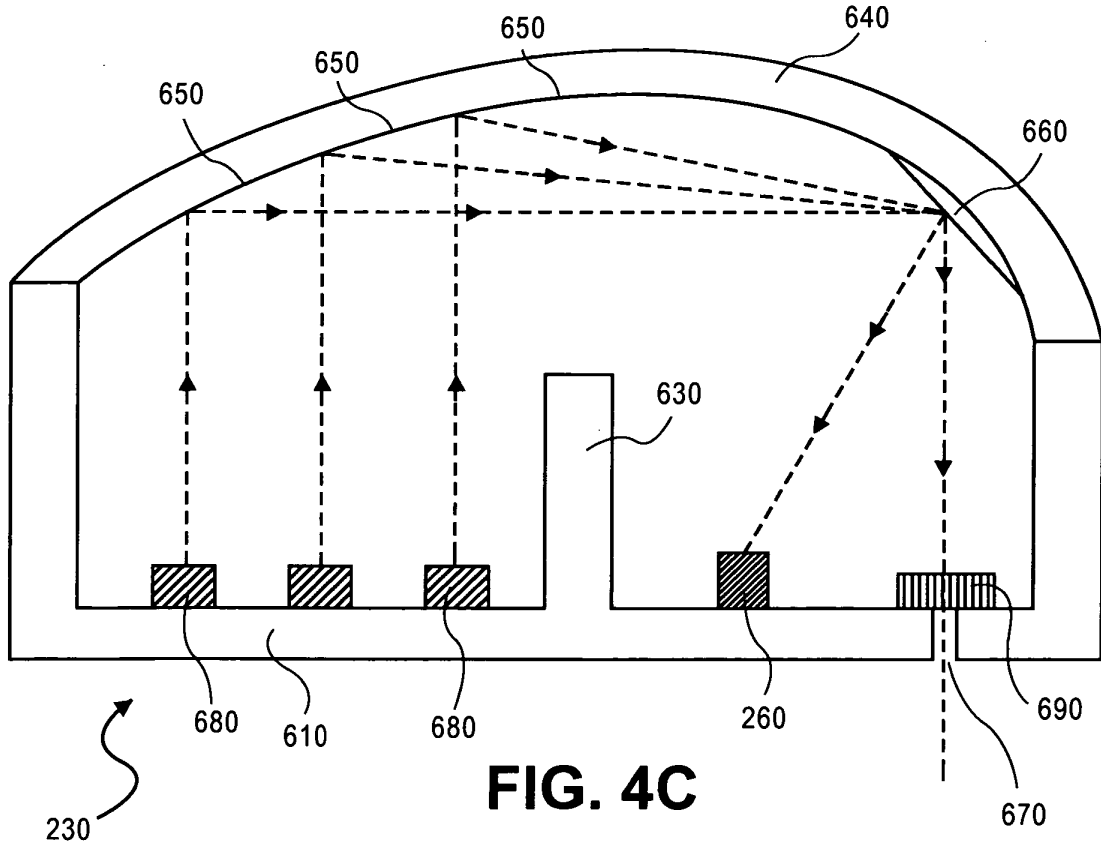
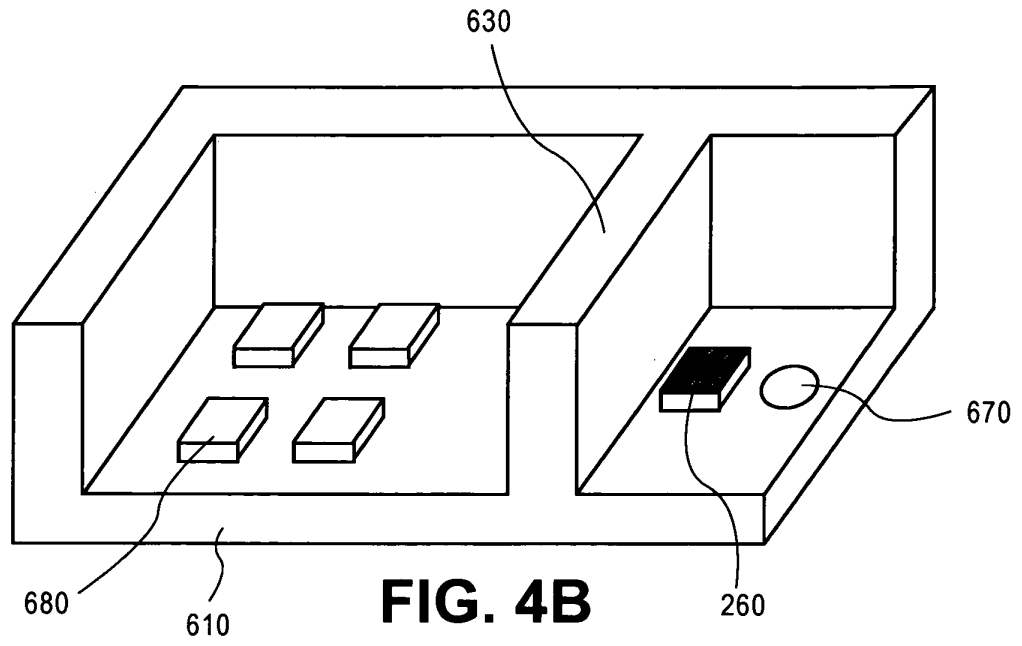


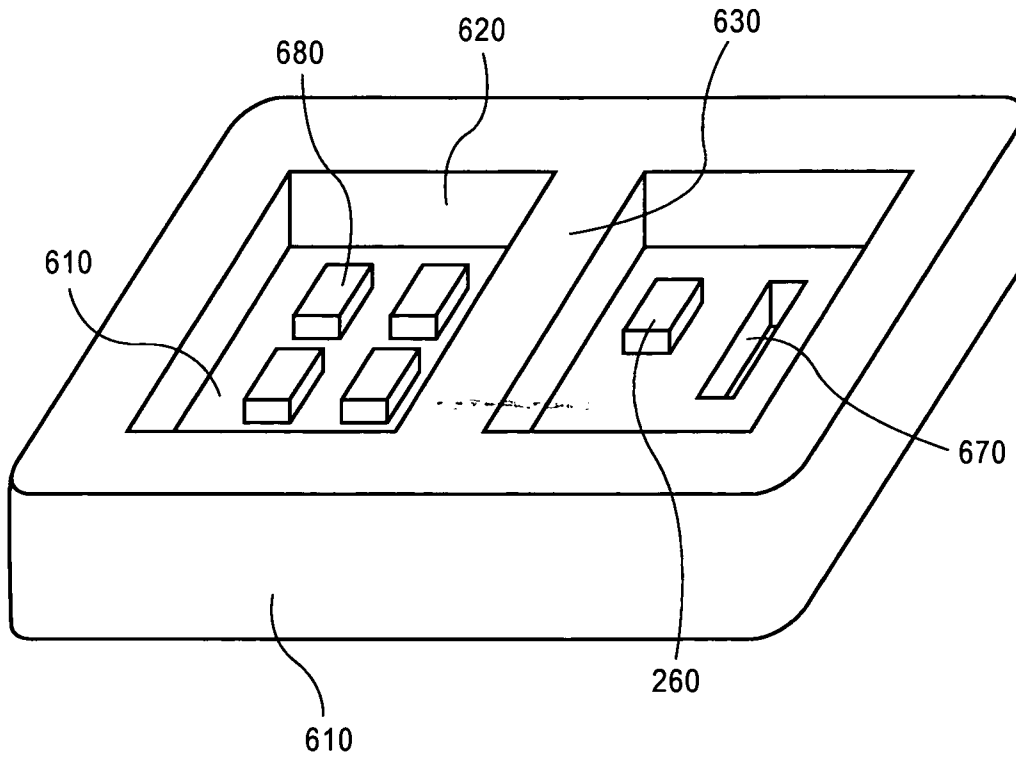
**FIG. 3N**



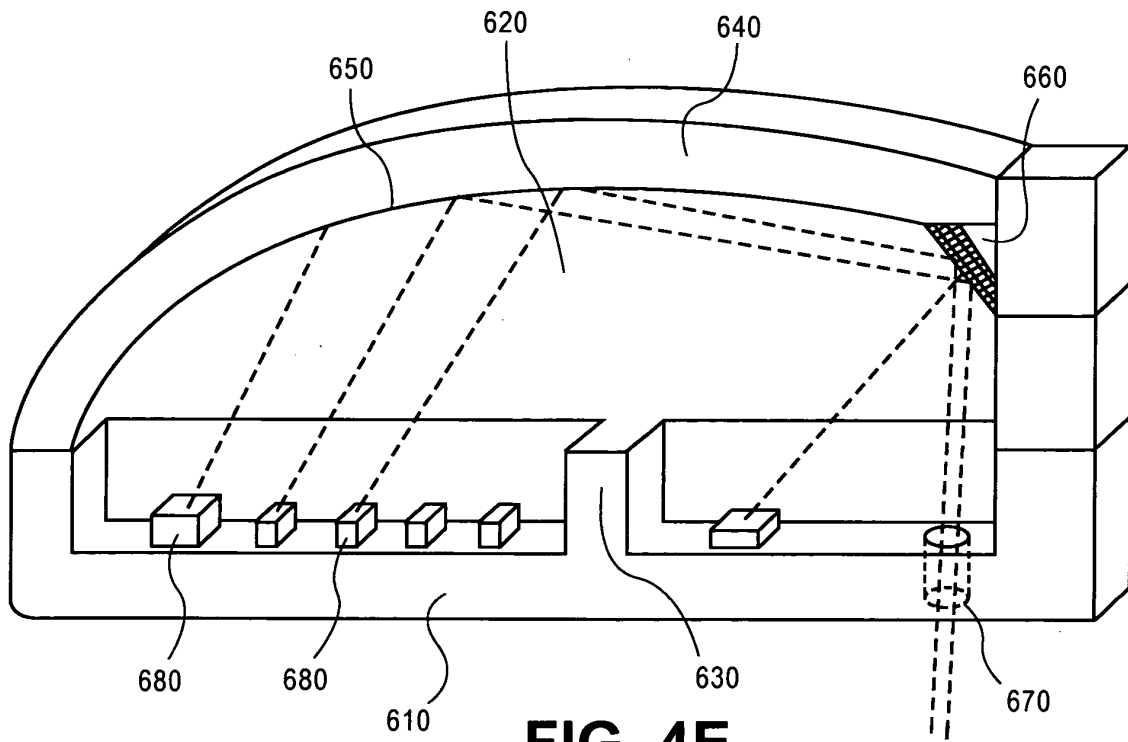


**FIG. 4A**

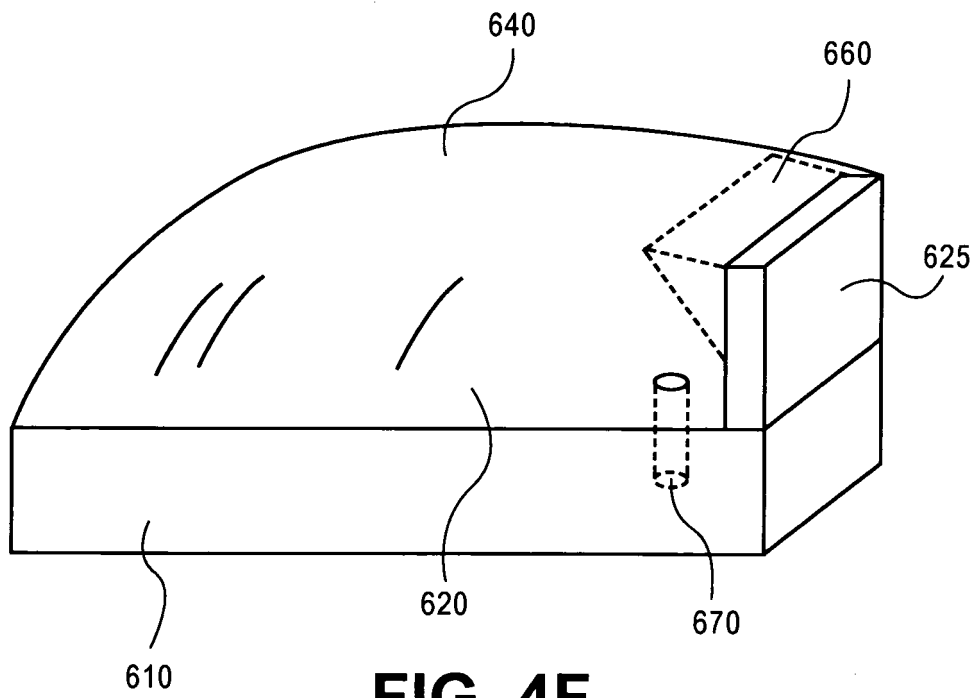




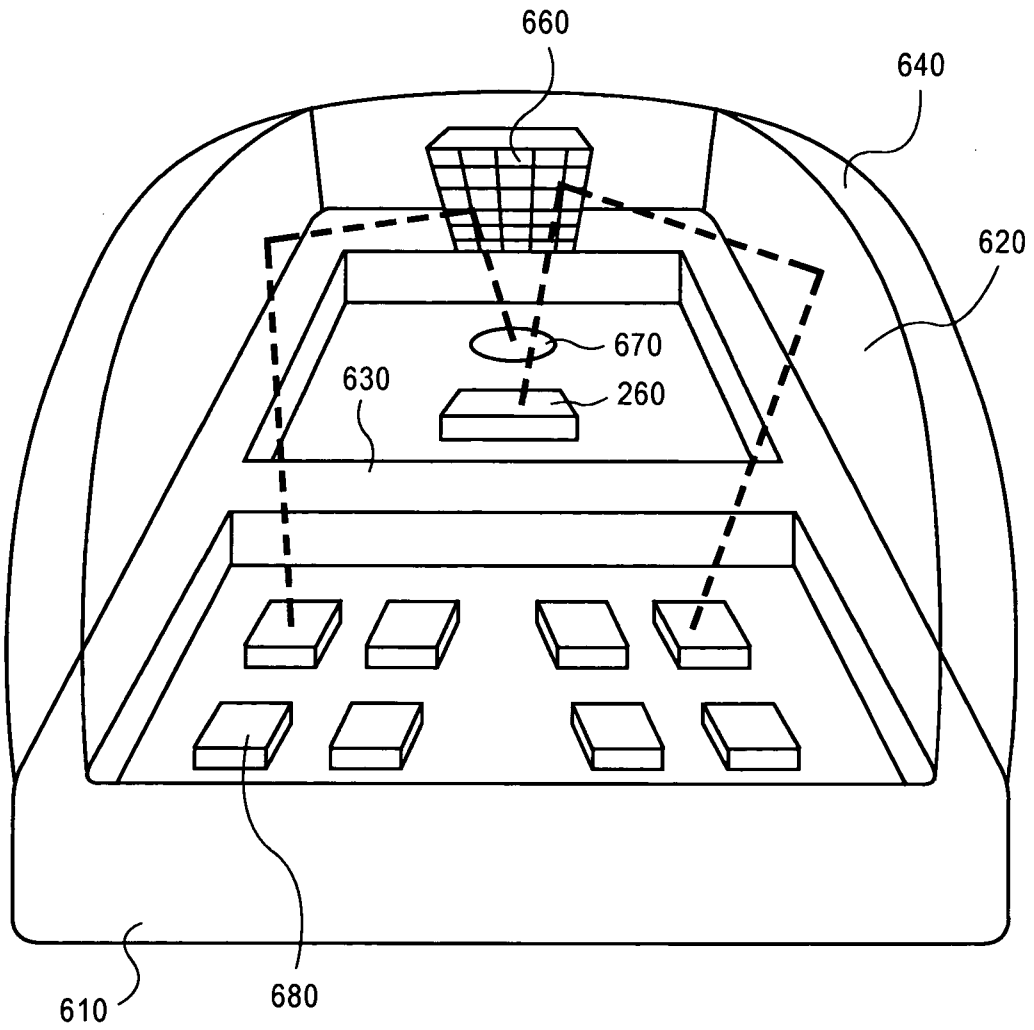
**FIG. 4D**



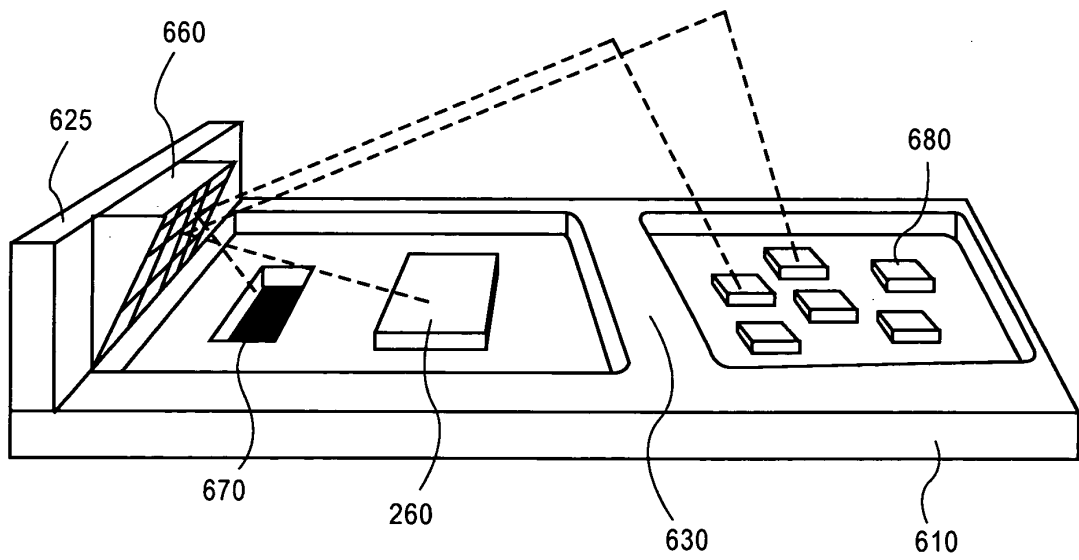
**FIG. 4E**



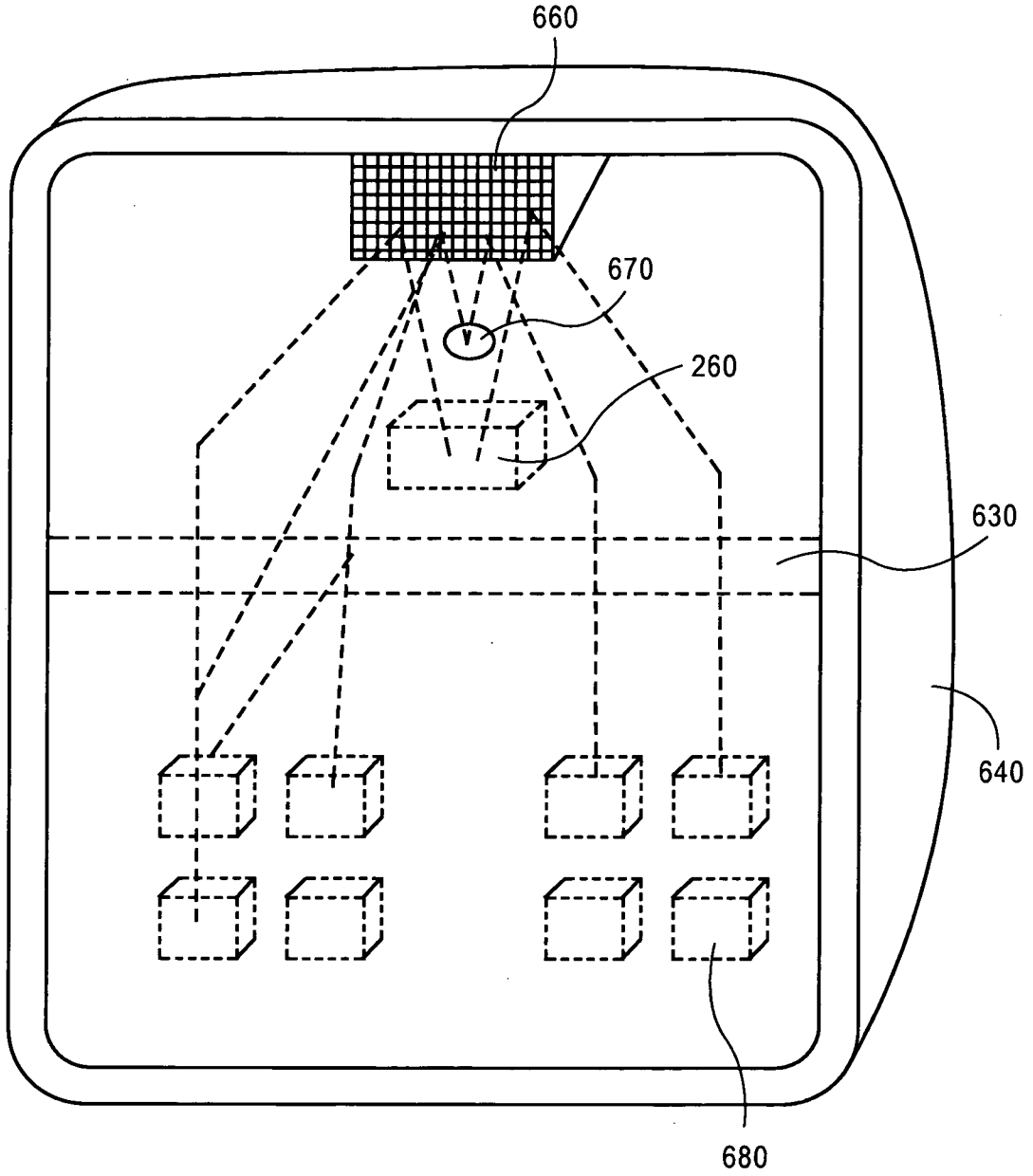
**FIG. 4F**



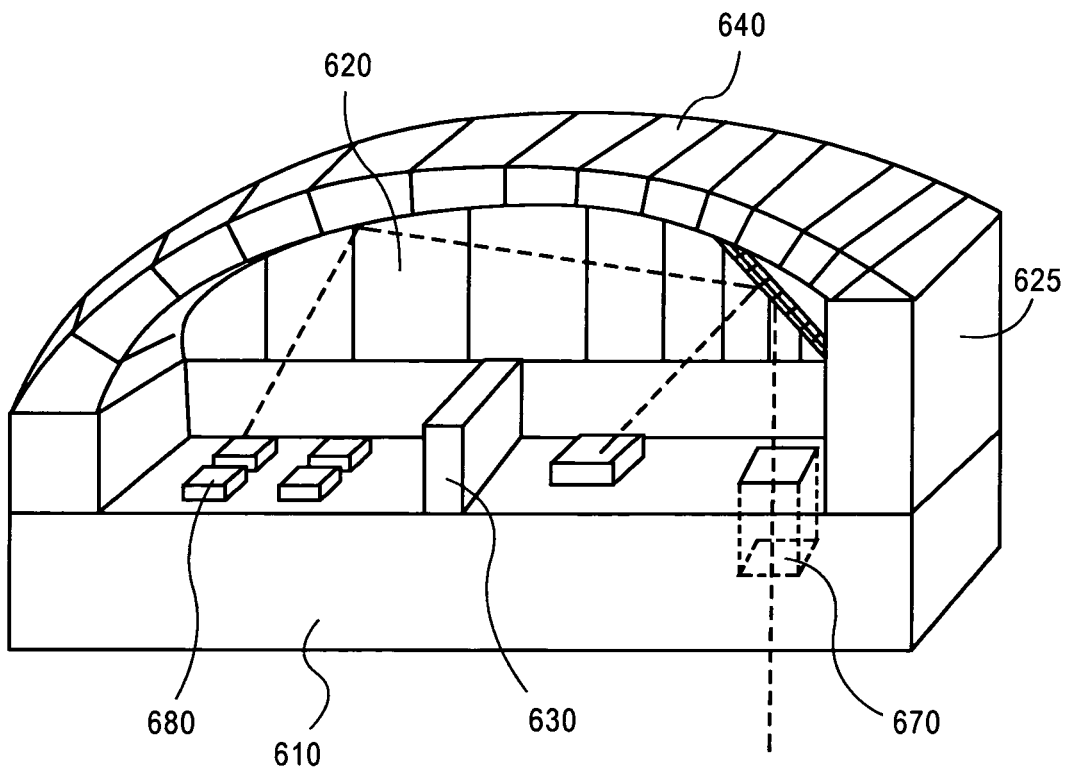
**FIG. 4G**



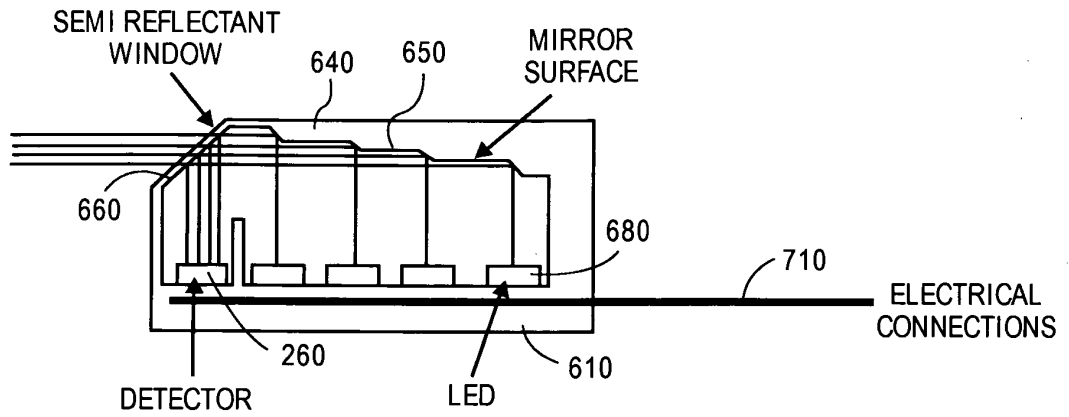
**FIG. 4H**



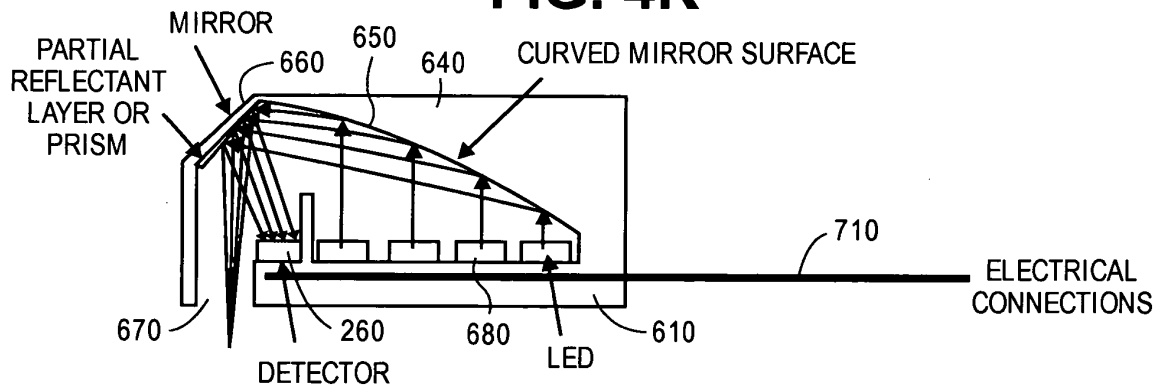
**FIG. 4I**



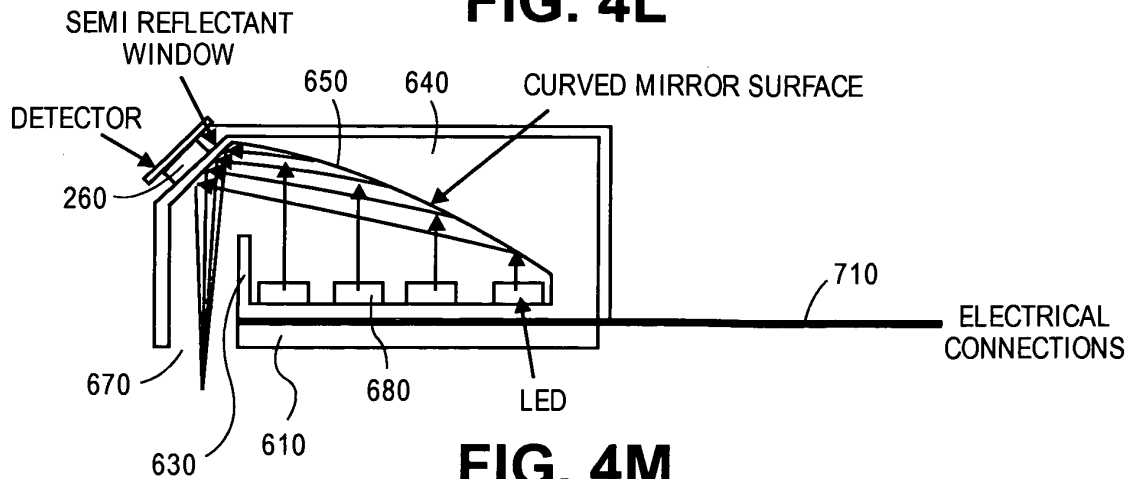
**FIG. 4J**



**FIG. 4K**



**FIG. 4L**



**FIG. 4M**

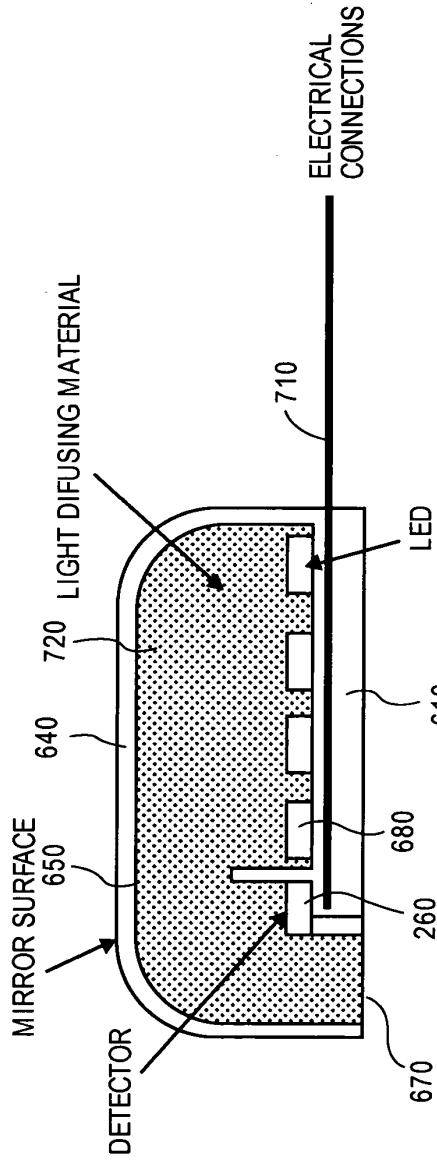


FIG. 4N

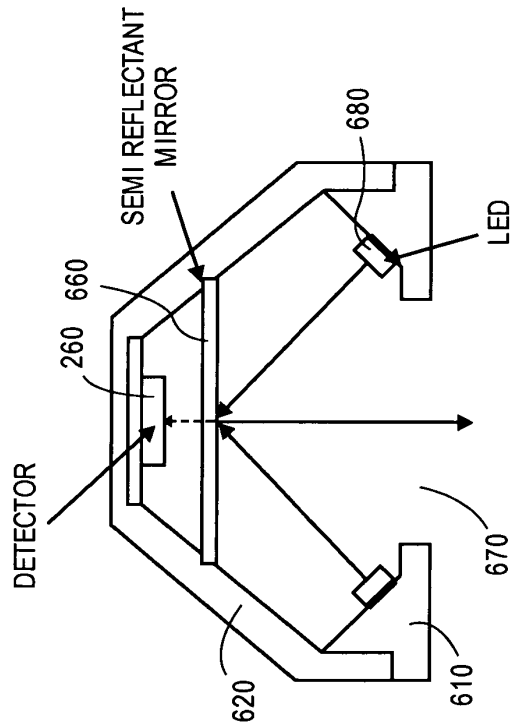
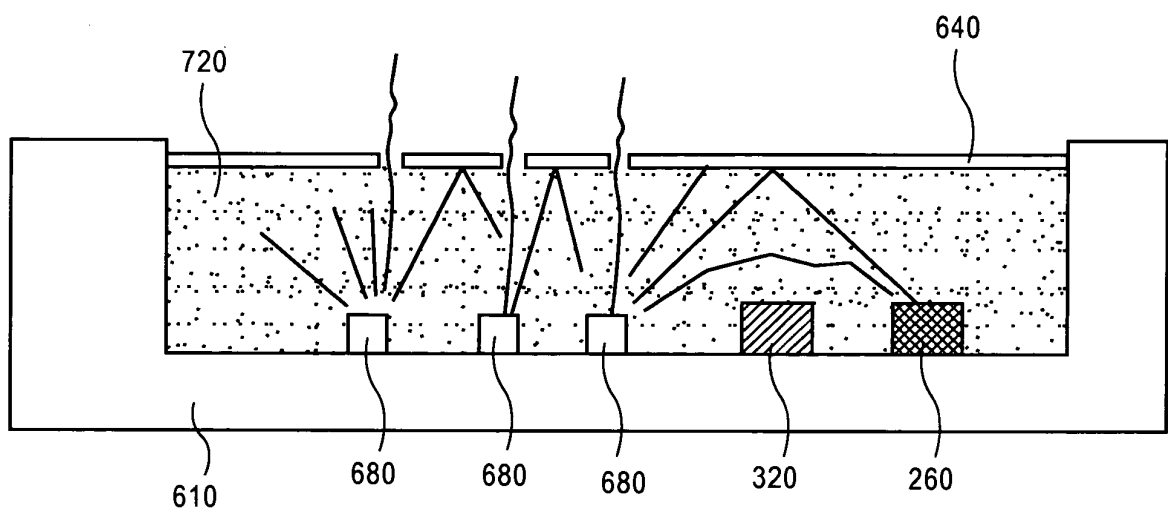
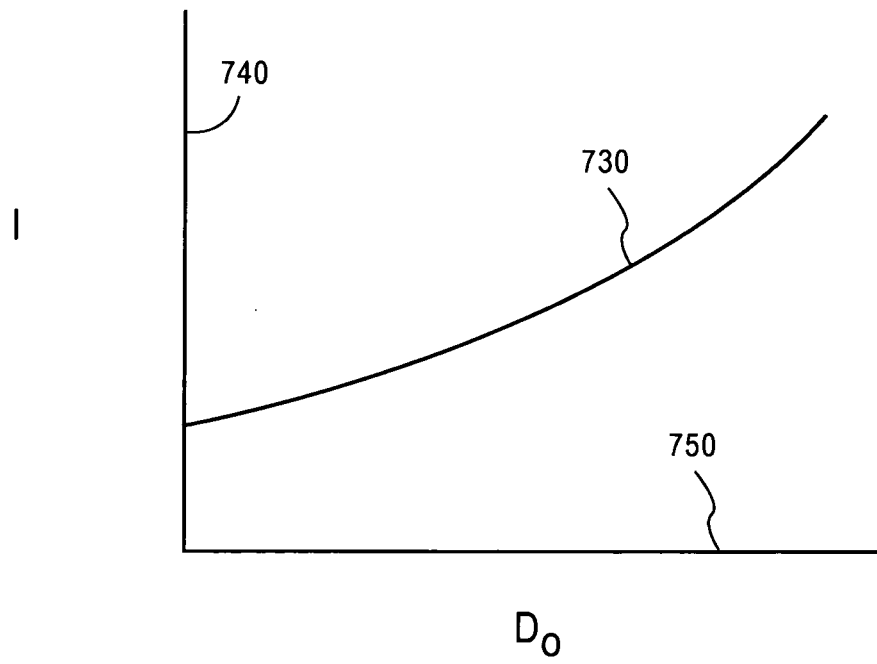


FIG. 4O

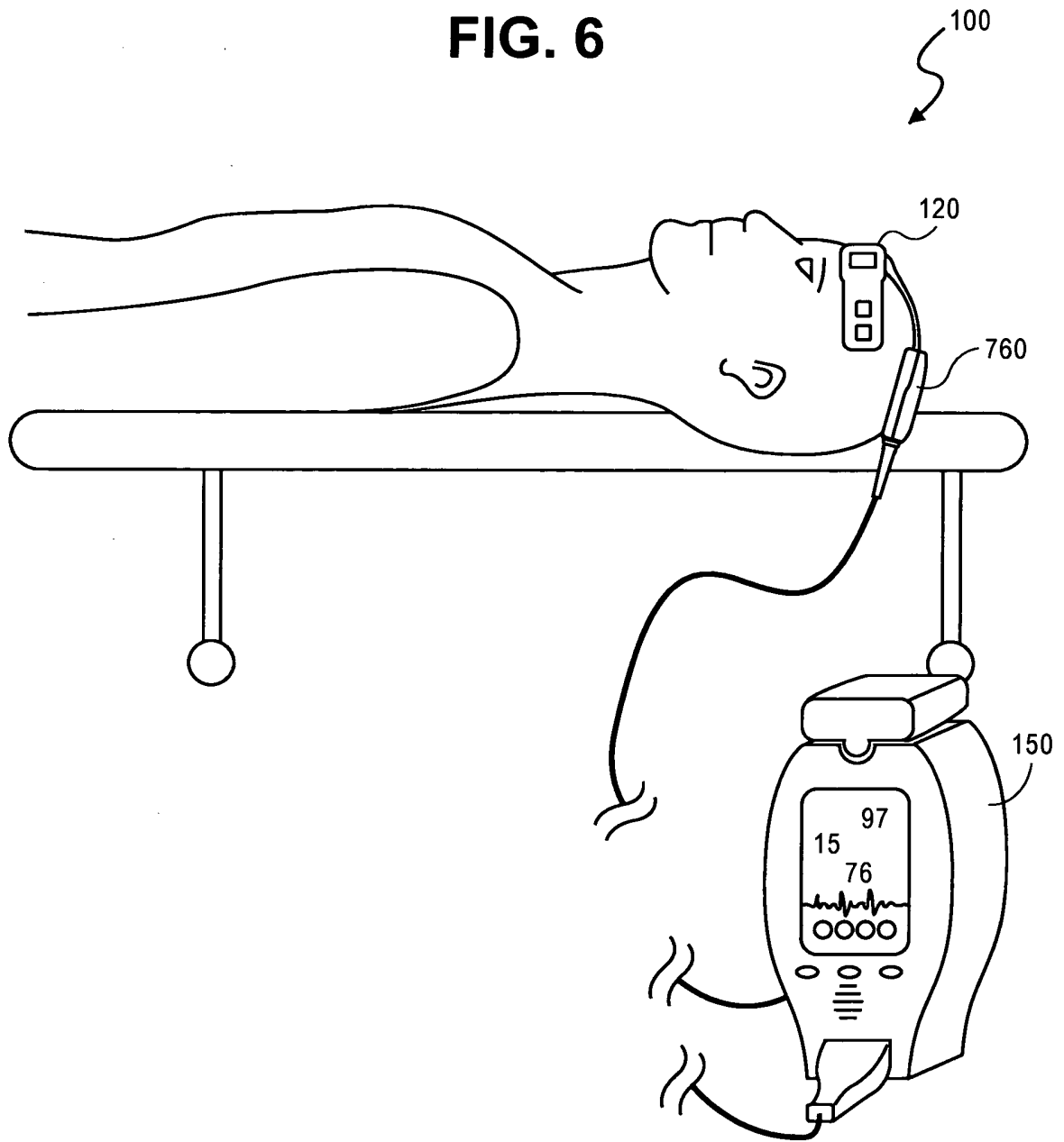


**FIG. 4P**



**FIG. 5**

FIG. 6



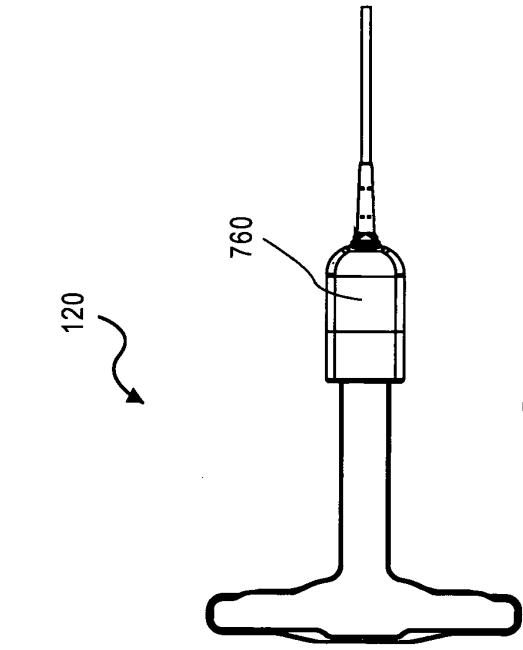


FIG. 7A

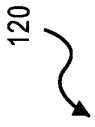


FIG. 7B

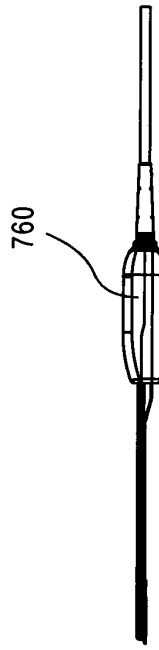


FIG. 7C

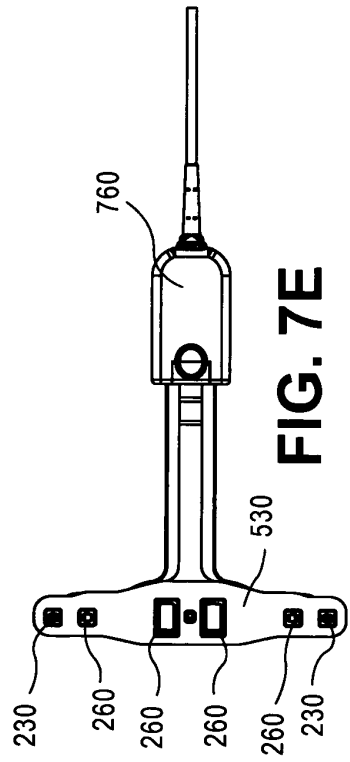


FIG. 7E

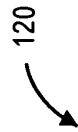
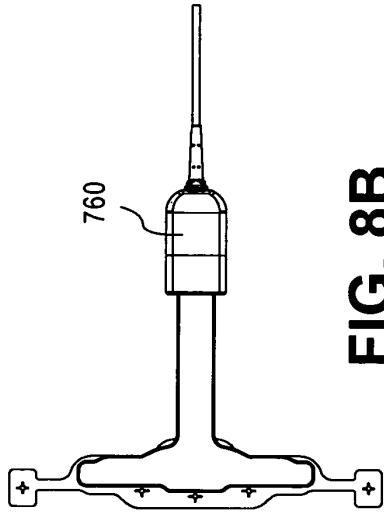
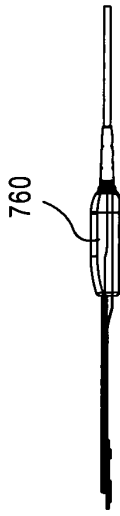


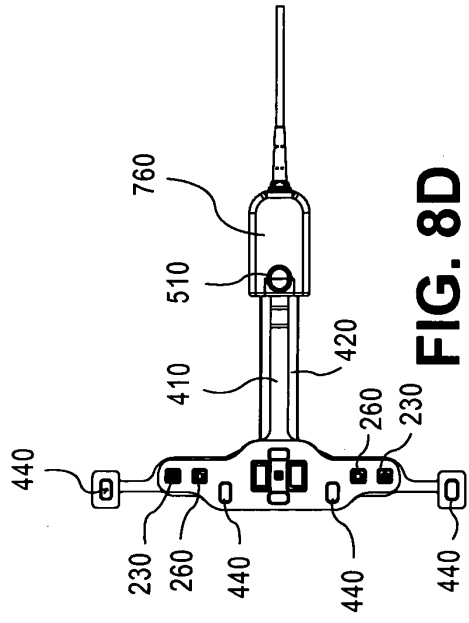
FIG. 7D



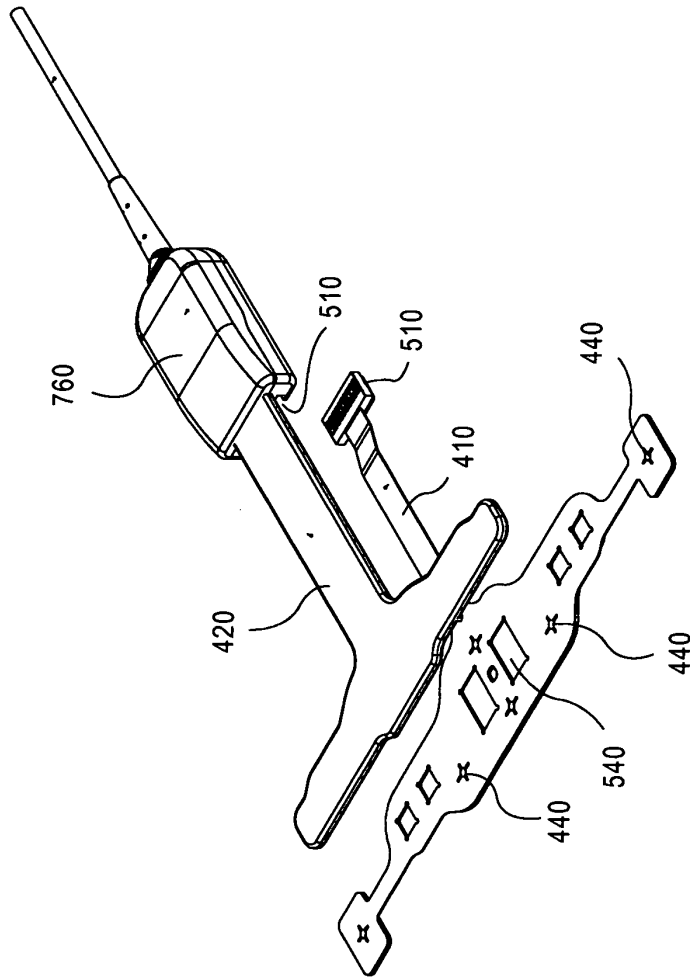
**FIG. 8B**



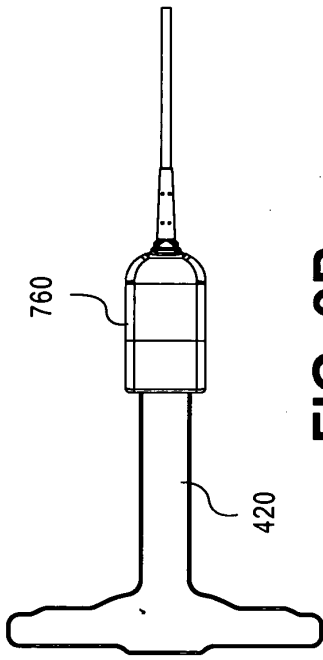
**FIG. 8C**



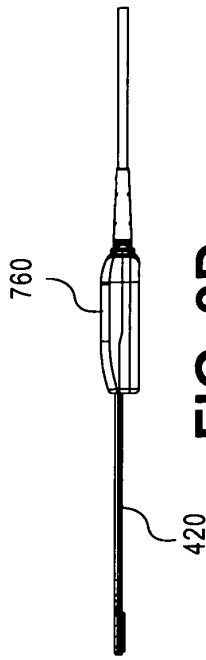
**FIG. 8D**



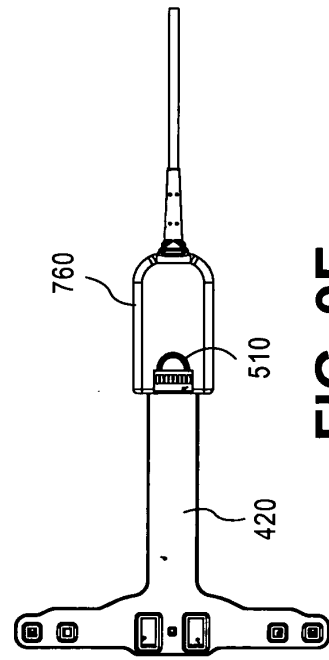
**FIG. 8A**



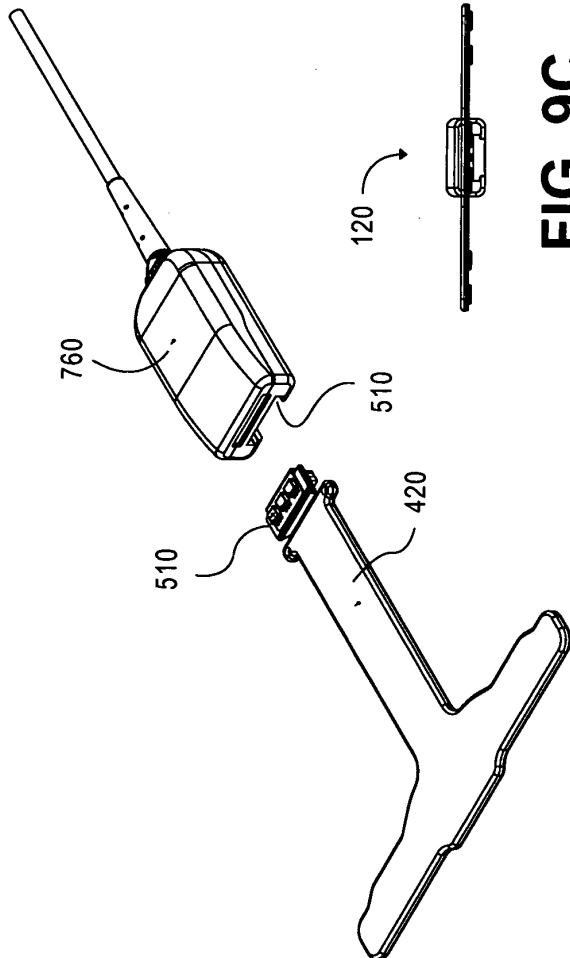
**FIG. 9B**



**FIG. 9D**



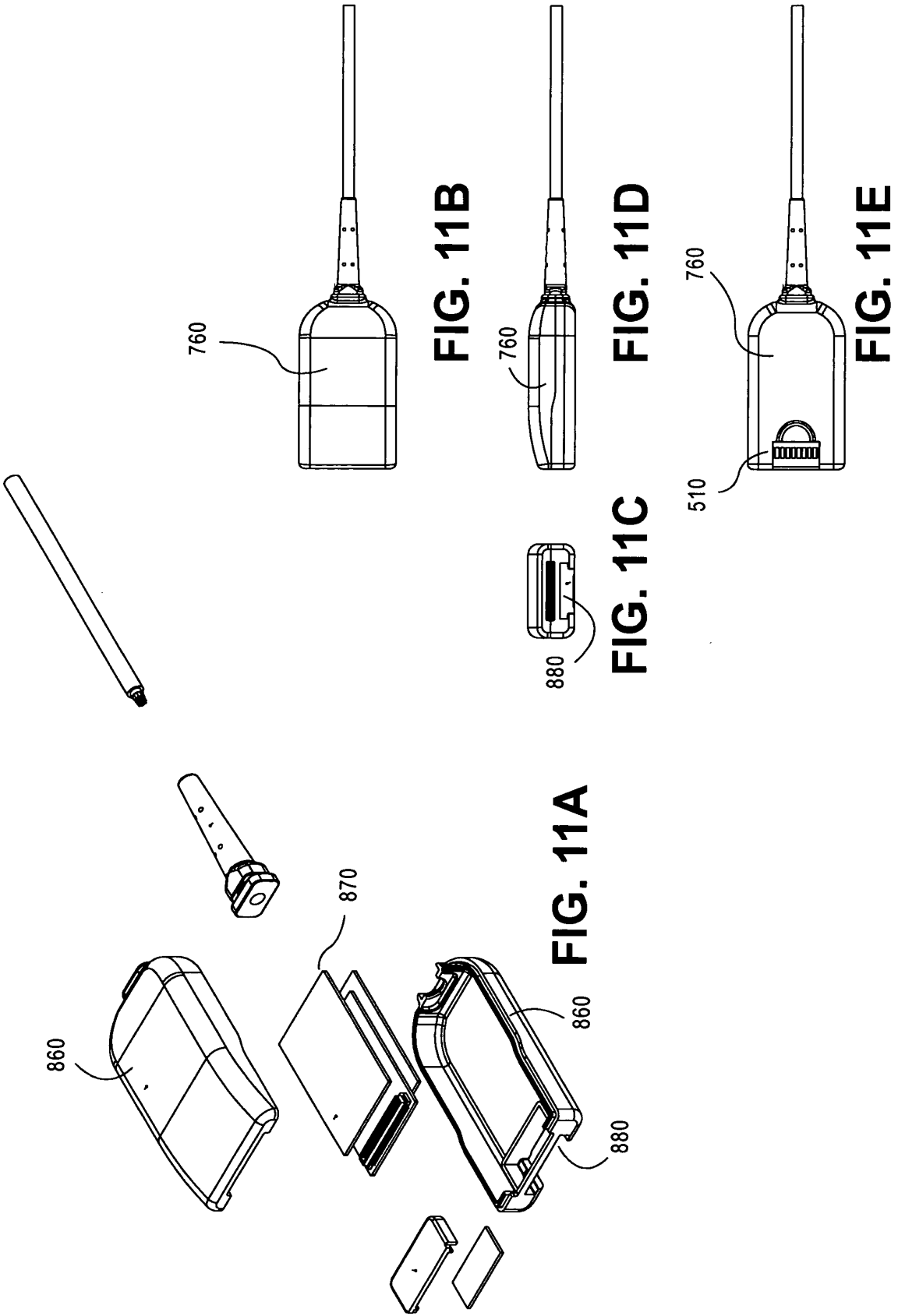
**FIG. 9E**

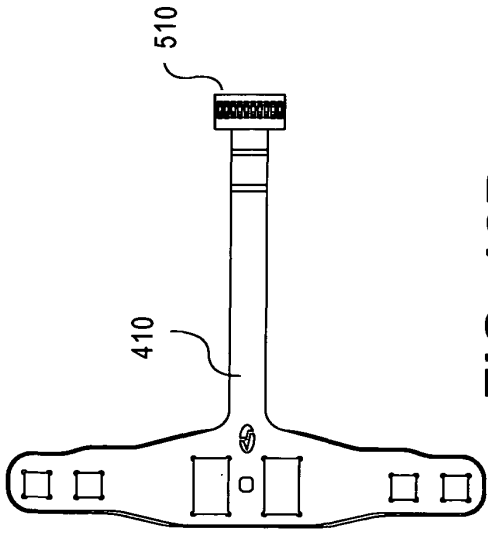


**FIG. 9C**

**FIG. 9A**



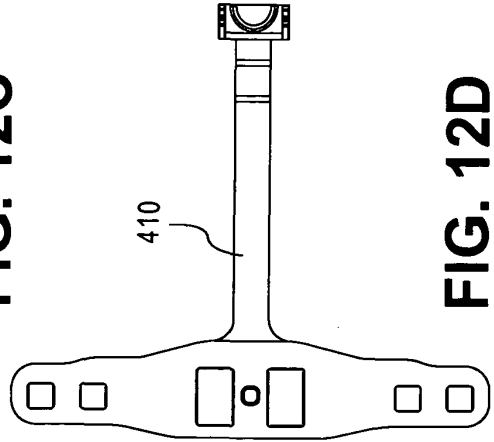




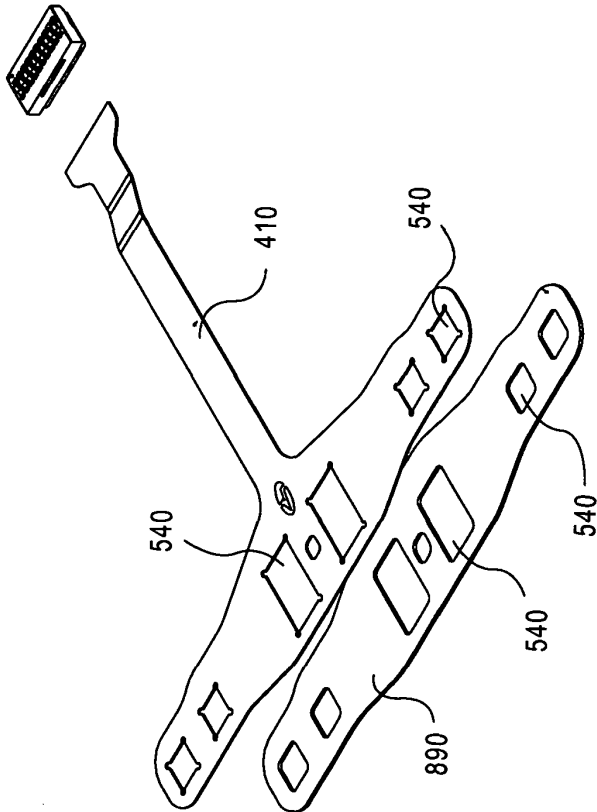
**FIG. 12B**



**FIG. 12C**



**FIG. 12D**



**FIG. 12A**



920 ↗

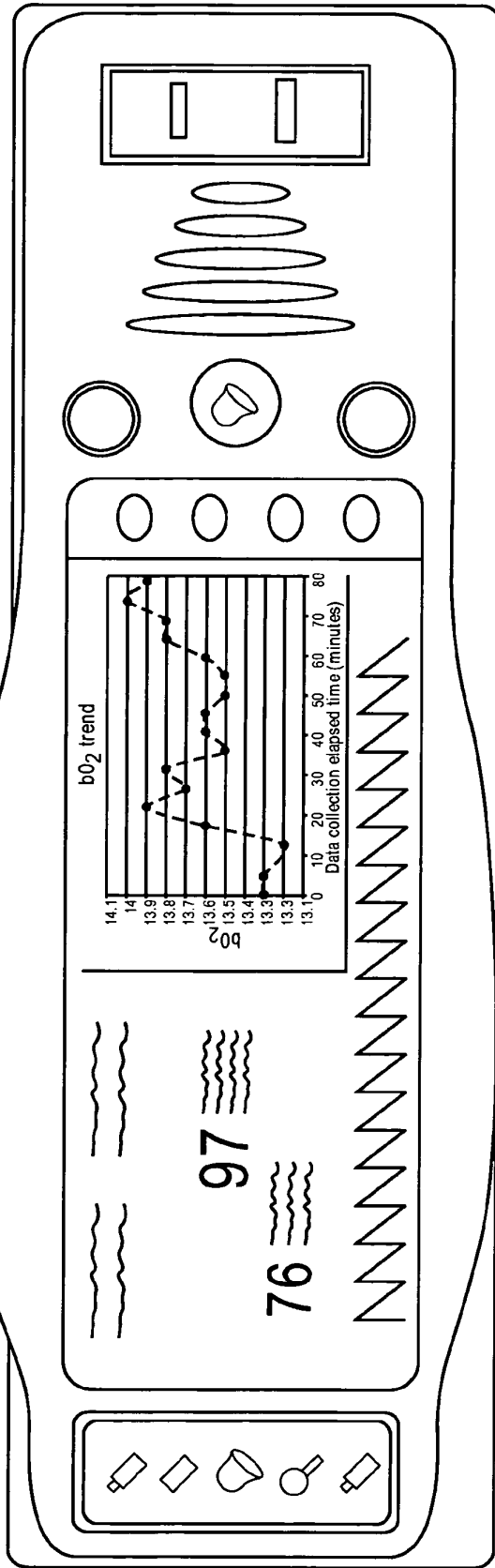


FIG. 14

**REFERENCES CITED IN THE DESCRIPTION**

*This list of references cited by the applicant is for the reader's convenience only. It does not form part of the European patent document. Even though great care has been taken in compiling the references, errors or omissions cannot be excluded and the EPO disclaims all liability in this regard.*

**Patent documents cited in the description**

- US 61387426 A [0001]
- US 2007208269 A [0006]
- US 6584336 B [0028]
- US 6661161 B [0028]
- US 6850788 B [0028]
- US 7415297 B [0028]
- US 20060211924 A [0028]
- US 20100030040 A [0028]
- US 5638818 A [0035]
- US 6285896 B [0035]
- US 6377829 B [0035]
- US 6580086 B [0035]
- US 6985764 B [0035]
- US 7341559 B [0035]
- US 60164444 B [0038]
- US 6654626 B [0038]
- US 6128521 A [0038] [0082]
- US 7072701 B [0039]
- US 7047054 B [0039]
- US 7341599 B [0059]
- US 6301493 B [0082]
- US 6317627 B [0082]
- US 6430437 B [0082]

专利名称(译)	意识深度监测包括血氧计		
公开(公告)号	<a href="#">EP2621333B1</a>	公开(公告)日	2015-07-29
申请号	EP2011768238	申请日	2011-09-27
[标]申请(专利权)人(译)	梅西莫股份有限公司		
申请(专利权)人(译)	Masimo公司		
当前申请(专利权)人(译)	Masimo公司		
[标]发明人	AL ALI AMMAR ABDUL HAFIZ YASSIR		
发明人	AL-ALI, AMMAR ABDUL-HAFIZ, YASSIR		
IPC分类号	A61B5/00 A61B5/0478 A61B5/1455		
CPC分类号	A61B5/0006 A61B5/0478 A61B5/14553 A61B5/6814 A61B5/0476 A61B5/048 A61B5/1455 A61B5/14551 A61B5/14552 A61B5/165 A61B5/4821 A61B5/6803 A61B5/6833 A61B5/742 A61B2562/164		
优先权	61/387457 2010-09-28 US		
其他公开文献	EP2621333A2		
外部链接	<a href="#">Espacenet</a>		

摘要(译)

本公开涉及一种用于监测患者意识深度的传感器。传感器包括多个光源，光检测器，并且在一些实施例中，包括电极。在一个实施例中，传感器包括可重复使用和一次性部分。

FIG. 1A

