



(12) **EUROPEAN PATENT APPLICATION**

(43) Date of publication:
10.04.2019 Bulletin 2019/15

(51) Int Cl.:
A61B 5/00 (2006.01) A61B 5/0408 (2006.01)

(21) Application number: **17382670.2**

(22) Date of filing: **06.10.2017**

(84) Designated Contracting States:
AL AT BE BG CH CY CZ DE DK EE ES FI FR GB GR HR HU IE IS IT LI LT LU LV MC MK MT NL NO PL PT RO RS SE SI SK SM TR
 Designated Extension States:
BA ME
 Designated Validation States:
MA MD

- **BLANCO SIERRA, Daniel**
08302 Mataró (ES)
- **NAVARRO GRUESO, Alberto**
28054 Madrid (ES)
- **GARCÍA PAREDES, Juan**
08191 Rubí (ES)

(71) Applicant: **Fundació Eurecat**
08290 Cerdanyola del Vallès (ES)

(74) Representative: **Juncosa Miró, Jaime et al**
Torner, Juncosa i Associats, S.L.
Gran Via de les Corts
Catalanes, 669 bis, 1^o, 2^a
08013 Barcelona (ES)

(72) Inventors:
 • **RODRÍGUEZ GUTIÉRREZ, Rosa**
08018 Barcelona (ES)

(54) **WEARABLE THORACIC ELEMENT FOR DETECTING, MONITORING AND REPORTING THE PHYSIOLOGICAL STATUS OF AN INDIVIDUAL**

(57) The thoracic element, in the shape of a band, comprises a support layer (5) including a first and second sensors (1),(2) and a processing unit (3) inside a casing (8). The first sensor (1) is a laminated strain gauge located on an elastic portion (5c) of the support layer (5) and the second sensor (2) is formed by a first and a second laminated electro-conductive elements (2a), (2b) cooperating to obtain an ECG measurement. Each of the

sensors (1), (2) includes at their ends a connector (21a, 21b, 11a, 11b) to be attached to terminals (4a), (4b) of the casing (8). The laminated electro-conductive elements are superimposed and separated by an electric insulating rigid laminar layer (6). The support layer has two openings (5a) and (5b) at a given distance, through which the electro-conductive elements (2a and 2b) can contact the skin of the individual.

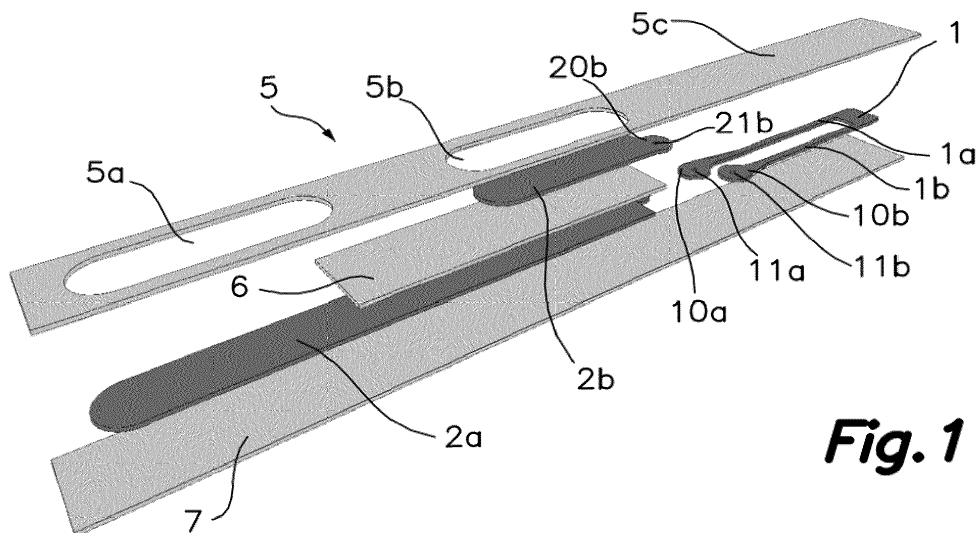

Fig. 1

Description

Technical field

[0001] The present invention relates to a wearable element, such as a wearable thoracic band for detecting, monitoring and reporting the physiological status of an individual by incorporating different sensors. The present device, in the form of a wearable thoracic band, hereby disclosed is destined, but not limited, to the monitoring of an individual's physiological parameters in an exercising environment. However it may also be used in order to monitor the physiological parameters of an individual from a medical point of view on a daily basis.

State of the Art

[0002] Many devices and systems, specifically related to wearable bands for the monitoring of physiological parameters relative to an individual, are known in the current state of the art and they are applicable to many fields: such as exercising or sport environments and medical or safety applications.

[0003] Document WO2005032366 discloses a device wherein sensors that detect predetermined physiological parameters such as: heart rate, respiratory rate, fluid balance in the body, among many other parameters have been coated or integrated onto a textile material of an outfit or accessory worn straight on the skin, such as a sensor band.

[0004] Furthermore, it states that the electro-conductive surfaces have been designed flexible such that the conductivity may not be weakened whilst the surface of the electro-conductive element stretches.

[0005] However, said document, discloses a very generic device without defining how the sensors are arranged on the textile material or the disposition of the different sensors relative to each other.

[0006] Document EP1639939, discloses a system for detecting, monitoring and reporting human physiological data. The system includes a sensor device which generates data indicative of one or more physiological parameters of an individual wherein said sensor is placed in proximity to a portion of the individual's body. Said system also includes a processing unit which is connected to a central monitoring unit which processes the data gathered by the sensor or sensors.

[0007] CN203662728U discloses a chest strap for detecting physiological parameters including one pair of EGG electrodes and an elastic portion with a breathing sensor. However, said document fails to disclose how the sensors are positioned on the wearable device and what kind of wearable device is used and how the different elements are arranged.

[0008] Document WO2017075703, discloses a bio-sensing garment apparatus and method for applying electrodes to a fabric substrate. The bio-sensing garments disclosed can be functional for a variety of appli-

cations, such as electrocardiography (ECG), electromyography (EMG) or Respiratory Inductance Plethysmography (RIP) among others.

[0009] The conductors and electrodes may be integrated into any kind of garment or textile fabric which can then be integrated into a garment or used independently.

[0010] Furthermore, some of the embodiments disclosed include scalable metal-based or carbon-based electrode systems to overcome disadvantages associated with textile-based electrodes.

[0011] The present device aims to solve several problems with the current wearable thoracic bands and other bio-sensing garments, known in the prior art through the use of a multi-layer configuration wherein some of the overlapping layers have specific functions, the materials used for the different layers which form said wearable band allowing the band to have different properties and the positioning of the sensors located inside the wearable band operating without connecting lines or cables among them.

Brief description of the invention

[0012] A wearable thoracic element is disclosed for detecting, monitoring and reporting the physiological status of an individual in an exercising environment but, it is not limited exclusively to this application. The thoracic element may also be used in order to monitor the status of an individual from a medical perspective such as the monitoring of elderly individuals or individuals with certain pathologies on a daily basis. It is known in the state of the art that said thoracic elements such as bands may comprise:

- 35 - A first sensor aimed to collect data regarding a physiological parameter of the individual wearing said thoracic band, used for determining the respiratory rate of the individual;
- 40 - a second sensor which collects data with regards to another physiological parameter of the individual wearing said thoracic band, for example used for determining the heart rate of the individual;
- 45 - a processing unit, situated inside a casing of small dimensions, to which both the first sensor and the second sensor are connected to process data from said sensors; and
- 50 - terminals for the first sensor and terminals for the second sensor, wherein said terminals are positioned in said casing to which the connectors of each sensor are connected in order for the processing unit to receive the data of the different physiological parameters being monitored.
- 55

[0013] The wearable thoracic element of this invention in the form of a band is characterised in that it is formed

by at least a primary layer.

[0014] The primary layer is a support layer that has two openings through which two electro-conductive laminated elements of one of the sensors are exposed resulting in the exposed portions of said electro-conductive elements acting as pads which can then be directly placed in contact with the individual in order to detect a physiological parameter. The support layer also includes an elastic portion onto which another sensor is placed which detects a second physiological parameter.

[0015] Both sensors are positioned adjacent to one another and on the same side of the band facing the user's body, of the support layer wherein the connectors of both sensors are in proximity to one another.

[0016] The casing containing the processing unit, which monitors and reports the data regarding the different parameters, is situated on the exterior side of a secondary layer, wherein said secondary layer acts as a covering layer.

[0017] In a preferred embodiment of this invention, a multi-layer configuration is used which may include a plurality of other layers such as: an electric insulating rigid laminar layer and a covering layer wherein said covering layer may act as an embellishment as well as a cover for the different sensors placed on the support band.

[0018] This multi-layer configuration and the positioning of the sensors inside of the thoracic band, substantially reduces the amount of cables or connections required.

[0019] The materials used for the different layers of the thoracic band may be either elastic, rigid, or in some cases the layers may be made up of several portions of different materials with different properties allowing any of the three layers to have both rigid and elastic portions according to the disposition of the different sensors.

[0020] In the case of the support layer, as it has previously been stated, it may be formed by a rigid or semi-rigid portion and an elastic portion which allows said portion to extend and adapt according to the individual's size and breathing.

[0021] The openings of the support layer, relative to the positioning of the second sensor, are located on the rigid portion of the support layer, which can be rigidized by placing an electric insulating rigid laminar layer in between the first and second electroconductive elements that form said second sensor, whereas the first sensor is positioned on the elastic portion of the support layer. In a preferred embodiment, the support layer is elastic throughout all its extension.

[0022] In a preferred embodiment, the materials used for the support and the covering layers of the thoracic band are elastic throughout all their extension wherein the covering layer covers the whole extension of the support layer and wherein said covering layer is an embellishment. As an example the material used for the support layer is a polyester fibre (PES), the material used for the covering layer is an elastomeric polyamide and the material used for the electric insulating rigid laminar layer is

a thermo-adhesive PVC which has electric insulating properties.

[0023] The casing, containing the processing unit is situated on the external side of the covering layer of the thoracic band with the terminals facing their respective connectors from both the first and second sensor respectively placed on the support layer.

[0024] In a preferred embodiment of the wearable thoracic band, the connectors and their respective terminals are snap connectors. However, the mechanism used to join the connectors of both sensors to their respective terminals connected to the processing unit may be any other kind of quick connect terminal known in the state of the art.

[0025] Furthermore, the wearable thoracic band is also characterised in that, the first sensor is a laminated strain gauge, located on an elastic portion of the support layer.

[0026] In an embodiment of the invention, said laminated strain gauge is made up of two parallel extended linear strips with a connector placed on connecting tabs at the end of each strip, wherein one of the strips is longer than the other and both strips are joined together at one end distal from said connectors and said linear strips are part of a single entity.

[0027] When the individual wearing the thoracic band breathes, the strain gauge expands and contracts which results in a variation of the resistivity of the sensor thus allowing the processing unit to monitor and report the breathing rate variations of the individual through the detection of the sensors resistivity variations.

[0028] The second sensor is formed by a first laminated electro-conductive element and a second laminated electro-conductive element each of them provided with connectors situated on connecting tabs at two adjacent ends. Said laminated electroconductive elements cooperate in performing an ECG measurement.

[0029] This second sensor is placed in a part of the support layer which must be positioned on a central part of the individual's chest area, wherein the support layer comprises a first opening and a second opening at a given distance, through which a portion of said electro-conductive elements are exposed so they are able to be in contact, functioning as pads, directly with the skin of the individual on the interior side of the support layer.

[0030] For the wearable thoracic band to function adequately, it must be worn in such a way that the two openings of the support layer are placed perpendicular to the mid-sagittal plane of the individual's body and the thoracic band must be placed approximately over the sternum with both openings positioned equidistantly from the sternum.

[0031] Therefore, the openings are located at both sides of a part of the support layer intended to be placed over a central part of the individual, so that the electro-conductive elements of the second sensor are located at both sides of said central part.

[0032] Once the thoracic band has been positioned in an optimal position, the two ECG laminated electro-con-

ductive elements detect the individual's heart rate by determining the potential difference between the two electro-conductive elements.

[0033] The first and second ECG electro-conductive elements are superimposed but separated by an electric insulating rigid laminar layer, in order to avoid any errors when the sensor is detecting the heart rate by determining the potential difference between both electro-conductive elements.

[0034] Both the first and second laminated sensors are covered, at least, by a portion of the covering layer.

[0035] In a preferred embodiment, the first and second sensors are made up of a thermoplastic polyurethane (TPU) material.

[0036] The wearable thoracic band, which integrates the first sensor (which monitors the respiratory rate of the individual) and the second sensor (which monitors the heart rate of the individual) is not limited exclusively to the use of these two sensors or the monitoring of the stated physiological parameters (respiratory and heart rate). The wearable thoracic band may include additional sensors which monitor other physiological parameters of the user or of his surroundings which are applicable to medical or exercising environments or the two mentioned sensors may detect and monitor different physiological parameters as the ones stated previously.

[0037] The connectors of both sensors are located in proximity and connected to terminals of the casing containing the processing unit, placed on the external side of the support layer.

[0038] It will be understood that references to geometric position, such as parallel, perpendicular, tangent, etc. allow deviations up to $\pm 5^\circ$ from the theoretical position defined by this nomenclature.

[0039] It will also be understood that any range of values given may not be optimal in extreme values and may require adaptations of the invention to these extreme values are applicable, such adaptations being within reach of a skilled person.

[0040] Other features of the invention appear from the following detailed description of an embodiment.

Brief description of the Figures

[0041] The foregoing and other advantages and features will be more fully understood from the following detailed description of an embodiment with reference to the accompanying drawings, to be taken in an illustrative and not limitative, in which:

- **Figure 1** illustrates a perspective view of the different elements that comprise the wearable thoracic band excluding the casing which includes the processing unit.
- **Figure 2** illustrates a front view of the different elements that comprise the wearable thoracic band excluding the casing.

- **Figure 3** illustrates a detailed view of the front of the covering layer and the rear side of the support layer.

- **Figure 4** illustrates a detailed view of the connection between the second sensors connectors and their respective terminals situated on the casing.

Detailed description of an embodiment

[0042] The foregoing and other advantages and features will be more fully understood from the following detailed description of an embodiment with reference to the accompanying drawings, to be taken in an illustrative and not limitative, in which:

Fig. 1 illustrates a perspective view, of one possible embodiment, of the different elements that comprise the wearable thoracic element in the form of a band although, the casing 8 containing the processing unit 3 and the terminals 4a and 4b, where the first sensor 1 and the second sensor 2 are connected, are not shown as they are positioned on the front side of the covering layer 7.

[0043] The first sensor 1, which is a laminated strain gauge, must be located on an elastic portion 5c of the support layer 5, if said support layer 5 is made up of several materials and not all of them are elastic and therefore there are different portions which comprise the support layer 5.

[0044] That is why, in order for the first sensor 1 to be able to expand and contract accordingly when the individual wearing the thoracic band inhales and exhales, allowing said first sensor 1 to detect the breathing rate of said individual, it must be located on an elastic portion 5c of the support layer.

[0045] According to a preferred embodiment, the support layer 5 is elastic throughout all its extension and the first sensor 1 of the wearable thoracic band is made up of two parallel extended strips 1 a and 1 b with a connector 11 a and 11 b placed on connecting tabs, 10a and 10b respectively, at the end of each strip, 1 a and 1 b respectively, wherein one of the strips 1 a is longer than the other strip 1 b and both strips 1 a, 1 b are joined together at one end distal from said connectors 11 a and 11 b and said linear strips 1 a, 1 b are part of a single entity.

[0046] The second sensor 2 is formed by a first ECG laminated electro-conductive element 2a and a second ECG laminated electro-conductive element 2b each of them provided with connectors 21 a and 21 b situated on connecting tabs, 20a and 20b respectively, at two adjacent ends, wherein the first 2a and second 2b ECG electro-conductive elements are superimposed but separated by an electric insulating rigid laminar layer 6, and the support layer 5 comprising a first opening 5a and a second opening 5b at a given distance, through which a portion of said electro-conductive elements 2a and 2b are exposed so they are able to be in contact, as pads, di-

rectly with the skin of the individual on the interior side of the support layer 5.

[0047] In order to improve the contact between the pads formed by electro-conductive elements 2a and 2b of the second sensor 2 and the individual, the pads may include membranes which absorb the individuals' perspiration as well as specialised hydrogel membranes which also improve the electro-conductive elements 2a and 2b contact.

[0048] The materials used for both the first 1 and second 2 sensors must be electrically conductive and at least the first sensor 1 must have good elasticity properties.

[0049] The materials used for the different layers 5 and 7 of the thoracic band are elastic albeit, they are not required to have the same properties or be the same elastic material and therefore, the positioning of the first and second sensors, 1 and 2 respectively, is irrelevant as long as they are adjacent to each other and on the same side of the support layer 5.

[0050] According to one embodiment, the covering layer 7 only covers the laminated sensors 1 and 2 although, in a preferred embodiment, the covering layer 7 covers the whole extension of the support layer 5 wherein said covering layer 7 also acts as an embellishment for the thoracic band.

[0051] Fig. 2 illustrates a front view of the wearable thoracic band where we can clearly observe the placement of the sensors 1 and 2 and the different layers 5, 6 and 7 that comprise the thoracic band. The casing 8 which includes the processing unit 3 and the terminals 4a and 4b for the first 1 and second 2 sensor respectively is not represented in this figure in order to simplify it.

[0052] According to one embodiment, the first sensor 1 and the second sensor 2 are situated on the front side of the support layer 5, as the rear side is in direct contact with the individual, and they are covered by the covering layer 7 wherein said covering layer 7 may cover the whole extension of the support layer 5 or only those portions of the support layer (5) where the first and second sensors 1 and 2 are placed.

[0053] The first sensor 1 is a strain gauge and the second sensor 2 is formed by the first laminated ECG electro-conductive element 2a and the second laminated ECG electro-conductive element 2b.

[0054] The support layer 5 has two openings: the first opening 5a through which the first laminated ECG electro-conductive element 2a is exposed and the second opening 5b through which the second laminated ECG electro-conductive element 2b is exposed. The shape of the openings 5a and 5b may be any shape known in the state of the art which allows an adequate contact between the electro-conductive elements 2a and 2b and the individual. The opening of the support layer 5 may also be formed by a single opening instead of multiple openings, as shown in this particular embodiment of the thoracic band.

[0055] Placed in between the first and second laminated ECG electro-conductive elements 2a and 2b is the

electric insulating rigid laminar layer 6.

[0056] The connectors 11 a, 11 b, 21 a and 21 b are placed at the end of connecting tabs 10a, 10b, 20a and 20b of both sensors 1 and 2 respectively located in proximity to each other with the connectors facing the terminals 4a and 4b located on the covering layer 7 relative to the position of the casing 8.

[0057] Fig. 3 illustrates a detailed view of the front of the covering layer 7 and the rear side of the support layer 5 in a preferred embodiment of the wearable thoracic band.

[0058] The front view of the covering layer (7) shows the disposition of the casing 8 wherein said casing 8 contains the processing unit 3 and is situated on the external (or front) side of the covering layer 7 of the thoracic band.

[0059] In a preferred embodiment, the casing 8 contains two terminals 4a for the first sensor 1 and its respective connectors 11 a and 11 b and two terminals 4b for the second sensor 2 and its respective connectors 21 a and 21 b wherein, the terminals 4a and 4b are located in proximity to each other.

[0060] The casing (8) should cover said terminals 4a and 4b of both the first 1 and second sensor 2, respectively, but the terminals 4a and 4b have been represented in order to visualize how they are positioned.

[0061] The rear view of the support layer 5, allows us to see the disposition of the first opening 5a relative to the first electro-conductive element 2a and the disposition of the second opening 5b relative to the second electro-conductive element 2b of the second sensor 2.

[0062] Fig. 4 illustrates an enlarged detailed view of the connection between the connectors 11 a and 11 b of the first sensor 1 and their respective terminals 4a situated on the casing 8. This detailed view of the connectors arrangement between the first sensor 1 and the terminals 4a of the casing 8 is applicable to the connection of the second sensor 2 to the terminals 4b of the casing 8.

[0063] The first connector 11 a placed on the connecting tab 10a relative to the extended strip 1 a and the second connector 11 b placed on the connecting tab 10b relative to the extended strip 1 b are connected to the terminals 4a situated on the casing 8.

[0064] The two extended strips 1 a and 1 b are parallel and wherein the extended strip 1 a is longer than the extended strip 1b corresponding to the first sensor 1 which is a laminated strain gauge.

[0065] In the case of the second sensor 2, the first connector 21 a is situated on the connecting tab 20a relative to the first electro-conductive element 2a and the second connector 21 b is situated on the connecting tab 20b relative to the second electro-conductive element (2b) which are connected to the terminals 4b situated on the casing 8 and wherein the terminals 4b are positioned on the same vertical axis.

[0066] The electric insulating rigid laminar layer 6 is placed in between the first and second electro-conductive elements 2a and 2b of the second sensor 2.

[0067] In a preferred embodiment of the wearable tho-

racic band, the connectors 11 a, 11 b, 21 a and 21 b and the terminals 4a and 4b are snap connectors.

[0068] It will be understood that various parts of one embodiment of the invention can be freely combined with parts described in other embodiments, even being said combination not explicitly described, provided there is no harm in such combination. Thus, the wearable thoracic element, in the form of a band previously disclosed, may be integrated into any kind of garment or textile fabric which can then be integrated into a garment or used independently.

Claims

1. Wearable thoracic element for detecting, monitoring and reporting physiological parameters of an individual, comprising the following elements integrated in said thoracic element:

- a first sensor (1) used for determining the respiratory rate of the individual;
- a second sensor (2) used for determining the heart rate of the individual;
- a processing unit (3), situated inside a casing (8) to which both the first sensor (1) and the second sensor (2) are connected, to process data from said sensors (1 and 2);
- terminals (4a) for the first sensor (1) and terminals (4b) for the second sensor (2), wherein said terminals (4a and 4b) are positioned in said casing (8);

characterised in that:

- the wearable thoracic element is formed by at least a support layer (5);
- the first sensor (1) is a laminated strain gauge located on an elastic portion (5c) of the support layer (5); and
- the second sensor (2) is formed by a first ECG laminated electro-conductive element (2a) and a second ECG laminated electro-conductive element (2b) each of them provided with connectors (21 a and 21 b) situated on connecting tabs (20a and 20b respectively) at two adjacent ends, wherein the first (2a) and second (2b) ECG electro-conductive elements are superimposed but separated by an electric insulating rigid laminar layer (6), and the support layer (5) comprising a first opening (5a) and a second opening (5b) at a given distance, through which a portion of said electro-conductive elements (2a and 2b) are exposed so they are able to be in contact, as pads, directly with the skin of the individual on the interior side of the support layer;

wherein said laminated sensors (1) and (2) are cov-

ered, at least, by a portion of a covering layer (7).

2. Wearable thoracic element according to claim 1 wherein, said laminated strain gauge is made up of two parallel extended linear strips (1 a and 1 b) with a connector (11 a and 11 b) placed on connecting tabs (10a and 10b respectively) at the end of each strip (1a and 1b respectively) wherein one of the strips (1a) is longer than the other strip (1b) and both strips (1 a, 1 b) are joined together at one end distal from said connectors (11 a and 11 b) and said linear strips (11 a, 11 b) are part of a single entity.
3. Wearable thoracic element according to claim 1 wherein, the connectors (11 a, 11 b, 21 a and 21 b) of both sensors (1 and 2 respectively) are located in proximity and connected to terminals (4a and 4b) of the casing (8) containing the processing unit.
4. Wearable thoracic element according to claim 3 wherein, the casing (8) containing the processing unit (3) is situated on the external side of the covering layer (7) of the thoracic element with the terminals (4a and 4b) facing their respective connectors (11 a, 11 b, 21 a and 21 b).
5. Wearable thoracic element according to claim 3 wherein, the connectors (11 a, 11 b, 21 a and 21 b) and the terminals (4a and 4b) are snap connectors.
6. Wearable thoracic element according to claim 1 wherein, the support layer (5) is elastic throughout all its extension.
7. Wearable thoracic element according to claim 6 wherein, the materials used for the support layer (5) and the covering layer (7) of the thoracic element are elastic throughout all their extension.
8. Wearable thoracic element according to claim 7 wherein, the material used for the support layer (5) is a polyester fibre (PES).
9. Wearable thoracic element according to claim 1 wherein, the material used for the electric insulating rigid laminar layer (6) is a thermo-adhesive PVC.
10. Wearable thoracic element according to claim 7 wherein, the material used for the covering layer (7) is an elastomeric polyamide.
11. Wearable thoracic element according to claim 10 wherein, the covering layer (7) covers the whole extension of the support layer (5) and wherein said covering layer (7) is an embellishment.
12. Wearable thoracic element according to any of the previous claims wherein, the first sensor (1) and the

second sensor (2) are made up of a thermoplastic polyurethane (TPU) material.

13. Wearable thoracic element according to claim 12 wherein, the openings (5a, 5b) are located at both sides of a part of the support layer (5) intended to be placed over a central part of the individual, so that the electro-conductive elements (2a and 2b) of the second sensor (2) are located at both sides of said central part.
14. Wearable thoracic element according to any of the previous claims wherein said element is a band.

5

10

15

20

25

30

35

40

45

50

55

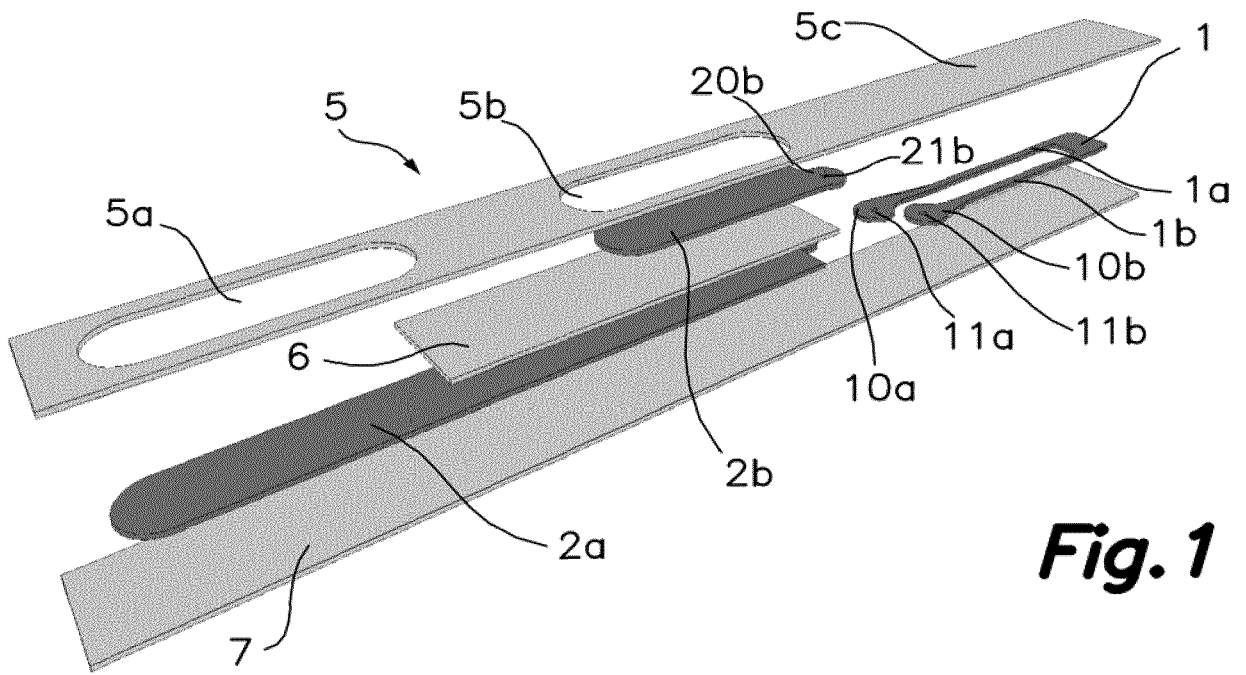

Fig. 1

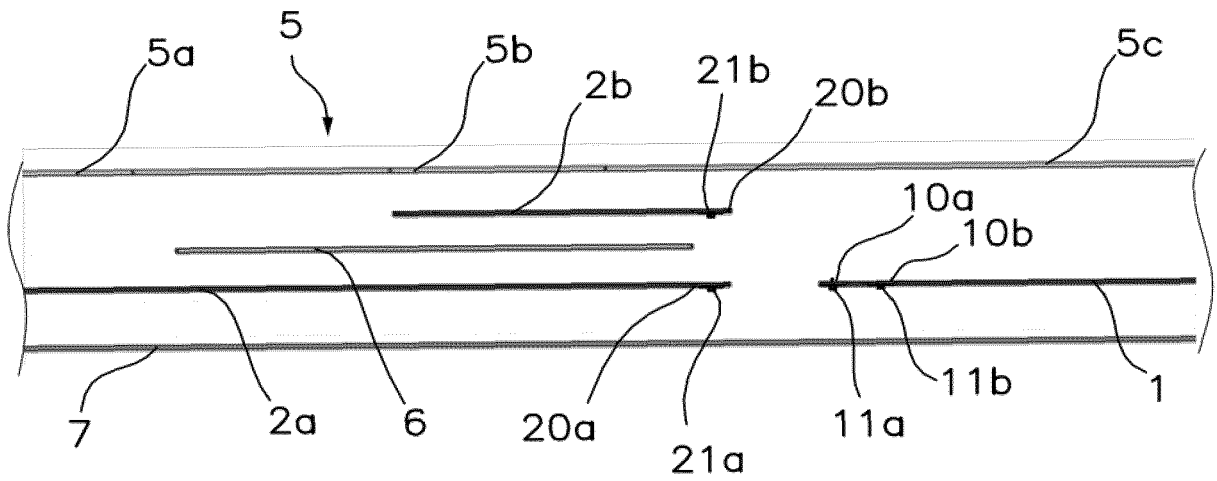

Fig. 2

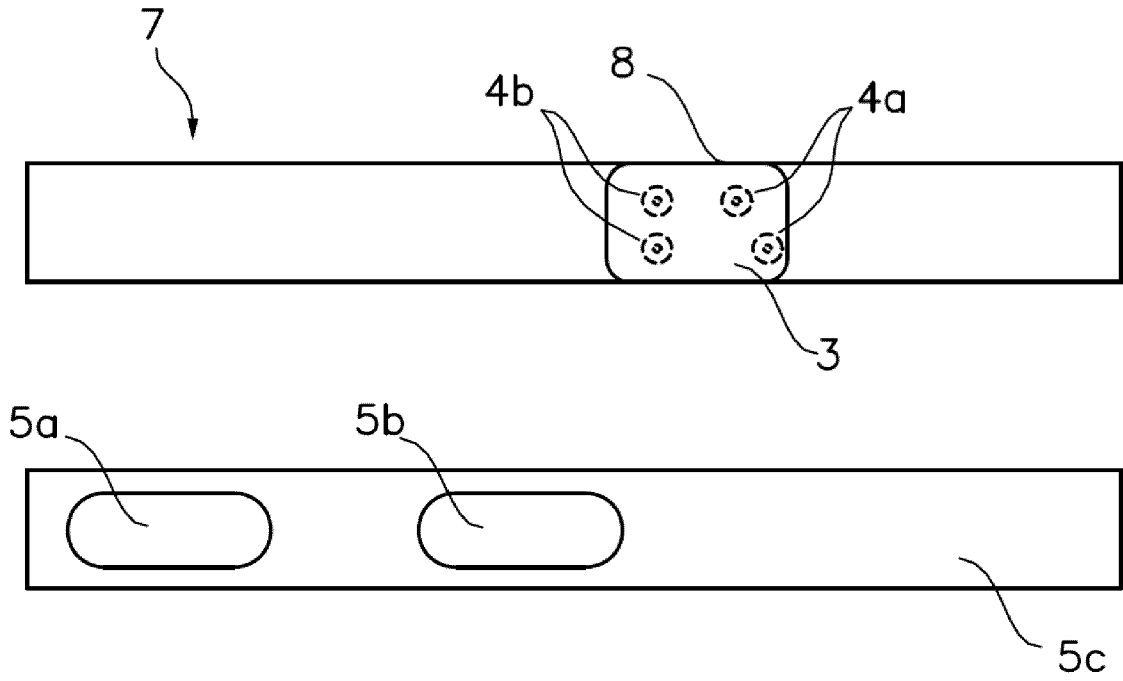

Fig. 3

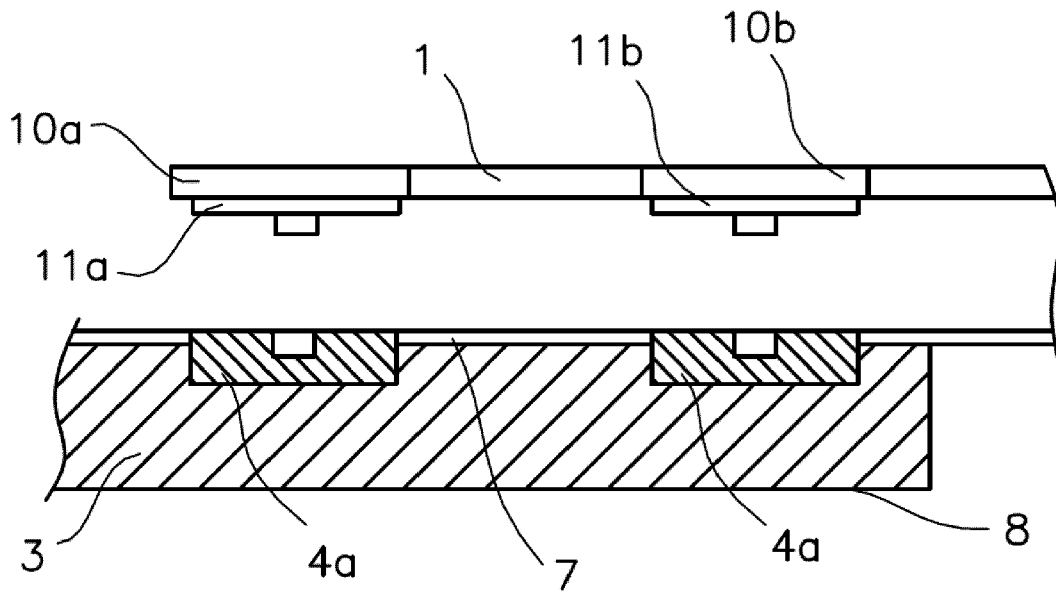

Fig. 4



EUROPEAN SEARCH REPORT

Application Number
EP 17 38 2670

5

10

15

20

25

30

35

40

45

50

55

DOCUMENTS CONSIDERED TO BE RELEVANT				
Category	Citation of document with indication, where appropriate, of relevant passages	Relevant to claim	CLASSIFICATION OF THE APPLICATION (IPC)	
X,D	WO 2017/075703 A1 (OM SIGNAL INC [CA]) 11 May 2017 (2017-05-11)	1,6-14	INV. A61B5/00 A61B5/0408	
Y	* paragraphs [1096], [1103], [1105], [1106]; figures 2A,3,6A,8 *	2-5		
Y	US 2014/343391 A1 (KORKALA SEPPO [FI] ET AL) 20 November 2014 (2014-11-20) * paragraphs [0027], [0029]; figure 3 *	1		
Y	JP H11 262476 A (NIPPON KODEN KOGYO KK) 28 September 1999 (1999-09-28) * figures 13,30,34 *	1,3-5		
A	US 2006/211934 A1 (HASSONJEE QAIZAR N [US] ET AL) 21 September 2006 (2006-09-21) * figure 2 *	1		
A	US 5 078 134 A (HEILMAN MARLIN S [US] ET AL) 7 January 1992 (1992-01-07) * column 7, line 67; figure 5 *	2		
Y	WO 2017/095861 A1 (UNIV DREXEL [US]) 8 June 2017 (2017-06-08) * last line of; page 5; figure 2 *	2		TECHNICAL FIELDS SEARCHED (IPC)
A	US 2008/091097 A1 (LINTI CARSTEN [DE] ET AL) 17 April 2008 (2008-04-17) * figure 1 *	2		A61B G06F
A	US 2016/120433 A1 (HUGHES NICHOLAS [US] ET AL) 5 May 2016 (2016-05-05) * figure 1 *	3		
A	US 6 141 575 A (PRICE MICHAEL A [US]) 31 October 2000 (2000-10-31) * figure 2 *	1		
The present search report has been drawn up for all claims				
Place of search The Hague		Date of completion of the search 20 March 2018	Examiner Visser, Robert	
CATEGORY OF CITED DOCUMENTS X : particularly relevant if taken alone Y : particularly relevant if combined with another document of the same category A : technological background O : non-written disclosure P : intermediate document T : theory or principle underlying the invention E : earlier patent document, but published on, or after the filing date D : document cited in the application L : document cited for other reasons & : member of the same patent family, corresponding document				

EPO FORM 1503 03 82 (P04C01)

ANNEX TO THE EUROPEAN SEARCH REPORT
ON EUROPEAN PATENT APPLICATION NO.

EP 17 38 2670

5 This annex lists the patent family members relating to the patent documents cited in the above-mentioned European search report.
The members are as contained in the European Patent Office EDP file on
The European Patent Office is in no way liable for these particulars which are merely given for the purpose of information.

20-03-2018

Patent document cited in search report	Publication date	Patent family member(s)	Publication date
WO 2017075703 A1	11-05-2017	NONE	
US 2014343391 A1	20-11-2014	EP 2803315 A1 US 2014343391 A1	19-11-2014 20-11-2014
JP H11262476 A	28-09-1999	JP 3656184 B2 JP H11262476 A	08-06-2005 28-09-1999
US 2006211934 A1	21-09-2006	AT 416818 T CA 2598705 A1 EP 1858581 A2 ES 2317533 T3 JP 4923038 B2 JP 2008536542 A KR 20070112387 A US 2006211934 A1 US 2007127187 A1 US 2008045808 A1 US 2009112079 A1 US 2011288394 A1 WO 2006101748 A2	15-12-2008 28-09-2006 28-11-2007 16-04-2009 25-04-2012 11-09-2008 23-11-2007 21-09-2006 07-06-2007 21-02-2008 30-04-2009 24-11-2011 28-09-2006
US 5078134 A	07-01-1992	CA 2043507 A1 DE 69121470 D1 DE 69121470 T2 EP 0459239 A2 JP H07541 A JP 3001301 B2 JP 3383611 B2 JP 3383612 B2 JP 3393092 B2 JP 2000051371 A JP 2000051372 A JP 2000051373 A US 5078134 A	30-11-1991 26-09-1996 09-01-1997 04-12-1991 06-01-1995 24-01-2000 04-03-2003 04-03-2003 07-04-2003 22-02-2000 22-02-2000 22-02-2000 07-01-1992
WO 2017095861 A1	08-06-2017	NONE	
US 2008091097 A1	17-04-2008	CN 1976632 A CN 101474002 A DE 102004030261 A1 EP 1773195 A2 EP 2036496 A2 ES 2642936 T3 ES 2643341 T3 JP 2008503287 A	06-06-2007 08-07-2009 19-01-2006 18-04-2007 18-03-2009 20-11-2017 22-11-2017 07-02-2008

EPO FORM P0459

For more details about this annex : see Official Journal of the European Patent Office, No. 12/82

55

ANNEX TO THE EUROPEAN SEARCH REPORT
ON EUROPEAN PATENT APPLICATION NO.

EP 17 38 2670

5 This annex lists the patent family members relating to the patent documents cited in the above-mentioned European search report.
The members are as contained in the European Patent Office EDP file on
The European Patent Office is in no way liable for these particulars which are merely given for the purpose of information.

20-03-2018

10

15

20

25

30

35

40

45

50

55

Patent document cited in search report	Publication date	Patent family member(s)	Publication date
		PT 1773195 T	16-10-2017
		PT 2036496 T	17-10-2017
		US 2008091097 A1	17-04-2008
		WO 2006000345 A2	05-01-2006

US 2016120433 A1	05-05-2016	AU 2015338967 A1	11-05-2017
		CA 2966180 A1	06-05-2016
		CN 107205679 A	26-09-2017
		EP 3212061 A1	06-09-2017
		JP 2018504148 A	15-02-2018
		KR 20170075012 A	30-06-2017
		US 2016120433 A1	05-05-2016
		US 2016120434 A1	05-05-2016
		US 2017188872 A1	06-07-2017
		WO 2016070128 A1	06-05-2016

US 6141575 A	31-10-2000	AU 9104398 A	08-03-1999
		CA 2300141 A1	25-02-1999
		DE 69832388 D1	22-12-2005
		DE 69832388 T2	03-08-2006
		EP 1003417 A1	31-05-2000
		EP 1637074 A1	22-03-2006
		US 6141575 A	31-10-2000
		WO 9908593 A1	25-02-1999

EPO FORM P0459

For more details about this annex : see Official Journal of the European Patent Office, No. 12/82

REFERENCES CITED IN THE DESCRIPTION

This list of references cited by the applicant is for the reader's convenience only. It does not form part of the European patent document. Even though great care has been taken in compiling the references, errors or omissions cannot be excluded and the EPO disclaims all liability in this regard.

Patent documents cited in the description

- WO 2005032366 A [0003]
- EP 1639939 A [0006]
- CN 203662728 U [0007]
- WO 2017075703 A [0008]

专利名称(译)	可穿戴胸部元件，用于检测，监测和报告个体的生理状态		
公开(公告)号	EP3466323A1	公开(公告)日	2019-04-10
申请号	EP2017382670	申请日	2017-10-06
[标]申请(专利权)人(译)	FUNDACIO EURECAT		
申请(专利权)人(译)	FUNDACIÓEURECAT		
当前申请(专利权)人(译)	FUNDACIÓEURECAT		
[标]发明人	ROIGUEZ GUTIERREZ ROSA		
发明人	RODRÍGUEZ GUTIÉRREZ, ROSA BLANCO SIERRA, DANIEL NAVARRO GRUESO, ALBERTO GARCÍA PAREDES, JUAN		
IPC分类号	A61B5/00 A61B5/0408		
外部链接	Espacenet		

摘要(译)

呈带状的胸部元件包括支撑层(5)，该支撑层(5)包括第一和第二传感器(1)，(2)以及壳体(8)内的处理单元(3)。第一传感器(1)是位于支撑层(5)的弹性部分(5c)上的层压应变仪，第二传感器(2)由第一和第二层压导电元件(2a)形成，(2b)合作以获得ECG测量。每个传感器(1)，(2)在其端部包括连接器(21a, 21b, 11a, 11b)，以连接到壳体(8)的端子(4a)，(4b)。层压的导电元件由电绝缘刚性层状层(6)叠加和分离。支撑层具有给定距离的两个开口(5a)和(5b)，导电元件(2a和2b)可以通过该开口接触个体的皮肤。

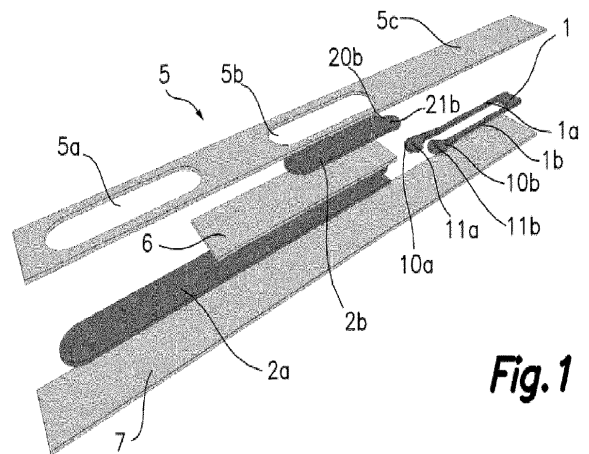

Fig. 1