



(11) **EP 1 188 412 B1**

(12) **EUROPEAN PATENT SPECIFICATION**

(45) Date of publication and mention of the grant of the patent:
04.04.2007 Bulletin 2007/14

(51) Int Cl.:
A61B 5/00 (2006.01)

(21) Application number: **01307734.2**

(22) Date of filing: **11.09.2001**

(54) **Portable ECG device with wireless communication interface to remotely monitor patients and method of use**

Tragbares EKG-Gerät mit drahtloser Kommunikationsschnittstelle zur Fernüberwachung von Patienten und zugehöriges Verfahren

Appareil d'électrocardiographie portable avec une interface de communication sans fil pour surveillance de patients à distance et méthode associée

(84) Designated Contracting States:
DE FI FR GB

(30) Priority: **13.09.2000 US 661064**

(43) Date of publication of application:
20.03.2002 Bulletin 2002/12

(73) Proprietor: **GE Medical Systems Information Technologies, Inc.**
Waukesha,
Wisconsin 53188 (US)

(72) Inventors:
• **Brodnick, Donald Eugene**
Cedarburg,
Wisconsin 53012 (US)

• **Rowlandson, Ian**
Fox Point,
Wisconsin 53217 (US)

(74) Representative: **Pedder, James Cuthbert**
London Patent Operation,
General Electric International, Inc.,
15 John Adam Street
London WC2N 6LU (GB)

(56) References cited:
WO-A-99/14882 **US-A- 5 544 661**
US-A- 5 704 364 **US-A- 6 102 856**

EP 1 188 412 B1

Note: Within nine months from the publication of the mention of the grant of the European patent, any person may give notice to the European Patent Office of opposition to the European patent granted. Notice of opposition shall be filed in a written reasoned statement. It shall not be deemed to have been filed until the opposition fee has been paid. (Art. 99(1) European Patent Convention).

Description

[0001] The invention relates generally to electrocardiograms (ECGs) and the use thereof, and more particularly to, a method and apparatus to remotely monitor patients using a portable ECG device with a wireless communication interface.

[0002] ECG analysis is a well established method for studying the function of the heart and identifying disorders of the heart. An ECG is a graphic tracing of the variations and the electrical potential caused by the excitation of the heart muscle as detected at the body surface by the leads of the ECG device. A normal electrocardiogram is a scale or representation that shows deflections resulting from cardiac activity as changes in the magnitude of voltage and polarity over time and includes a P-Wave, a QRS complex, a T-Wave, and a U-Wave. These waves are then analyzed using a set of rules and parameters to determine what is normal and what is not. Certain deviations are used to flag possible complications.

[0003] ECG is an important tool in diagnosing patients presented to an emergency room with chest pain. One particular disorder that is studied using ECG is acute cardiac syndromes (ACS), which includes, but is not limited to, acute myocardial infarction (AMI) and acute cardiac ischemia (ACI), the latter of which is commonly referred to as unstable angina. Acute ischemia, or unstable angina, includes the starvation of oxygen to a portion of the heart, commonly caused by a partial blockage, and acute infarction is the complete blockage of oxygen to a portion of the heart. Ischemia can lead to or be a symptom of myocardial infarction. It is well known that time is critical in diagnosing these conditions in a patient experiencing chest pain.

[0004] Unstable angina, or ischemia, is sometimes difficult to diagnose and differentiate from other causes of chest pain which are not life threatening. However, since ischemia can lead to AMI, and since time to treatment is critical once AMI sets in, it is advantageous to properly diagnose an ischemic patient as soon as possible. For example, once AMI sets in, the benefit of applying treatment is reduced significantly when the elapsed time from the onset of AMI chest pain to treatment exceeds six hours. Unfortunately, patients often delay in seeking treatment when they first experience chest pain, which compromises the opportunity that exists for salvaging the heart muscles affected via treatment, such as thrombolytic therapy. Further exasperating this problem, studies have shown that patients who are under the care of a physician, and/or have previously experienced AMI, delay the most in seeking care. This may be due to the fact that the patients do not wish to "bother" the physician for "mild" pain. It may also be due to the fact that the patients may have had false alarms in the past that resulted in a long wait at the hospital.

[0005] It would therefore be advantageous if a physician, or health care provider, could supply a device to

this type of patient that could expedite diagnosis and treatment by alleviating the embarrassment and time expense of showing up in an emergency department when in fact, no cardiac problem exists. This could eliminate not only the time involved in a patient going to the emergency room for indigestion, but also saves hospital resources and health insurance costs.

[0006] US 5,704,364 discloses a system comprising all the features of the preamble of claim 1 for the concurrent retrieval of medical data from a patient and communication between the patient and a remote healthcare provider.

[0007] A method and apparatus is disclosed herein to remotely monitor ECG data from a patient using a portable ECG device with a wireless communication interface that solves the aforementioned problems.

[0008] According to a first aspect of the present invention, there is provided a portable ECG device comprising an ECG monitor connected to a plurality of lead wires, each lead wire having a transducer capable of receiving an ECG signal from a patient, the ECG monitor having a processor to process the ECG signals from the plurality of lead wires and produce ECG data representative of cardiac condition of the patient; and a wireless communication interface coupled to receive patient ECG data from the ECG monitor and to transmit patient ECG data to a health care provider; wherein the processor is programmed to prompt the patient if assistance is needed to acquire an ECG, and if so, open a data transmission link to the health care provider; otherwise, receive and process the ECG signals, then open a data transmission link and transmit the ECG data to the health care provider.

[0009] In a further aspect, the present invention provides a method for remotely retrieving ECG data from a patient, in which an ECG device as defined hereinbefore is provided. Still a further aspect of the present invention provides an ECG monitor system comprising an ECG device as hereinbefore defined.

[0010] In general, the invention includes the use of a multi-lead, multi-channel ECG monitor that allows 24-hour surveillance by a qualified clinician at a central facility, or hospital, of a patient experiencing symptomatic ischemia without requiring costly hospitalization. The ECG monitor is coupled with a communications device that will automatically communicate with the centralized facility, which may be a hospital, or could be a separate facility providing a specialized service to a hospital. To provide simplicity of use, the system should not require the patient to remember a phone number and require dialing the phone number when the patient is in the middle of experiencing chest pains, and preferably, there should be no extra device to plug into a wall outlet which may be time-consuming and difficult for some patients when experiencing ischemic symptoms.

[0011] Therefore, in accordance with one aspect of the invention, a portable ECG apparatus is disclosed that includes an ECG monitor connected to a plurality of lead wires and a plurality of transducers, capable of receiving

a plurality of ECG signals from the patient. The ECG wireless communication device is coupled to receive patient ECG data from the ECG monitor and transmit the patient ECG data to a health care provider. The wireless communication interface can include a wireless mobile phone preconfigured to communicate directly with the health care provider and transmit voice and ECG data concurrently over a single connection. Audio communication will assist a clinician to ascertain the patient's symptoms and guide the patient in use of the device, if that is necessary. Another implementation for the wireless communication interface includes the use of an Internet appliance which has infrared communication capability to communicate with the remote ECG monitor and transmit data over the Internet. Transmission of ECG data then can also include video signals in addition to audio signals.

[0012] In accordance with another aspect of the invention, an ECG monitoring system is disclosed having a remote ECG monitor with multiple leads and multiple channels to acquire ECG signals from the patient. A remote communication and interface is coupled to the remote ECG monitor to receive the ECG signals from the remote ECG monitor and transmit the ECG signals over a public communication system to a centralized facility. A local communication interface is provided to receive the ECG signals from the public communications system at the centralized facility. A local ECG device is located in the centralized facility to connect to the local communication interface and receive the ECG signals and provide the ECG signals to a clinician or doctor in human discernable form.

[0013] In accordance with yet another aspect of the invention, a method of remotely monitoring ECG data from a patient includes providing an ECG device to a patient experiencing symptomatic ischemia for use remotely from a health care facility. The ECG device has communication capabilities to transmit ECG signals/data to a centralized facility. The method includes acquiring a multi-channel ECG from the patient at a location remote from a health care facility, transmitting the multi-channel ECG to the centralized facility, and assessing the multi-channel ECG at the centralized facility by a trained clinician or a doctor. The method also includes providing instructions to the patient based on the ECG assessment, which can include dispatching an ambulance in critical care situations. The method can also include offering remote interactive assistance in the use of the ECG device, if requested by the patient. Additionally, the patient's location can be confirmed if the patient becomes unconscious and the patient's exact location cannot be confirmed through the remote communication interface.

[0014] The invention will now be described in greater detail, by way of example, with reference to the drawings, in which:-

Fig. 1 is a block diagram of an electrocardiogram device incorporating the apparatus of the present invention.

Fig. 2 is a high level flow chart depicting an algorithm at least partially incorporated into the apparatus of Fig. 1 and showing the method of the present invention.

Fig. 3 is a functional block diagram of one implementation of the present invention.

Fig. 4 is a functional block diagram of another implementation of the present invention.

Fig. 5 is a detailed flow chart of an algorithm programmed into the electrocardiogram device of Fig. 1.

[0015] Referring to Fig. 1, an electrocardiograph device 10, in accordance with the present invention, is shown optionally connected to an information management system 12 through a communications link 14. A commonly used device for acquiring an ECG is a 12-lead ECG, such as the GE Marquette MacVu or Seer-MC equipped with 12SL™. The ECG device 10 and the information management system 12 receives power 16 from an external source. Among other things, the information management system 12 includes a central processing unit 18 connected to a memory unit, or database, 20 via a data link 22. The memory unit 20 may be RAM, ROM, a mass storage unit, a floppy disk, or any other computer readable storage medium, or a combination thereof. The CPU 18 processes data and is connected to an output, such as printer 24 and/or display 26. Alternatively, the electrocardiograph 10 can be connected directly to a printer 24 or display 26 through communications link 14 if the optional information management system 12 is not utilized.

[0016] The ECG device 10 is connected to a plurality of patient lead wires 28, each having a transducer 30 to receive ECG signals from a patient 32 in a known manner. The ECG device 10 has a signal conditioner 34 that receives the ECG signals and filters noise, sets thresholds, segregates signals, and provides the appropriate number of ECG signals for the number of leads 28 to an A/D converter 36 which converts the analog signals to digital signals for processing by a microcontroller 38, or any other type of processing unit. Microcontroller 38 is connected to a memory unit 40, similar to memory unit 20, or any other computer readable storage medium. In a preferred embodiment, memory unit 40 is a combination of ROM and RAM, wherein the ROM is used for static data, such as computer programs, and the RAM is used for dynamic data, such as the ECG signals received from patient 32.

[0017] A power supply 42 is provided to supply isolated power 44 to the signal conditioner 34 and the A/D converter 36 and provide an isolation barrier 46 to isolate the lead wires 28 from un-isolated power 48 and line voltage 16. Such electrical isolation is typically provided by a medical grade isolation transformer, an optical device, or battery operation.

[0018] The ECG device 10 also includes a wireless communication device, such as wireless phone 50, which may be built into the ECG device 10, or may be an external module. The wireless phone 50 receives signals 52 from the microcontroller 38 and is capable of transmitting voice and ECG data 54 concurrently. The wireless phone 50 is powered by the uninsulated power source 48. The wireless phone may be, what is commonly known as, a cellular phone, a digital phone, or a multi-mode phone. ECG device 10 can also include an interactive Internet appliance 56 connected to a television 58, to provide interactive audio and visual communication with patient 32. The ECG device 10 includes an infrared transmitter 60 to communicate with an infrared receiver 62 of the Internet appliance 56. The Internet appliance 56 is also equipped with an infrared transmitter 64 to communicate with an infrared receiver 66 of the ECG 10. Operation of this ECG monitor system will be further described with reference to Figs. 2-5. Alternatively, the Internet appliance 56 and television 58 can equivalently be integrated into a single unit or a personal computer with an Internet connection could equivalently serve the function of an "Internet appliance." Generally then, the "Internet appliance" is any device capable of transmitting such data over an interconnected communication system, such as the Internet.

[0019] Referring now to Fig. 2, a high level flow chart of the process 100 and use of a system incorporating the apparatus of Fig. 1 is shown. The process 100 begins with providing an ECG device, such as that described with reference to Fig. 1, to a patient experiencing symptomatic ischemia for use remotely from a health care facility 102. As will be described with further detail with reference to Figs. 3 and 4, the ECG device includes communication capabilities to transmit raw ECG signals, or process ECG data to a centralized facility. The use of the ECG device starts when the patient experiences symptoms 104. If the patient is not familiar with using the device and the overall process 106, 108, the patient telephones the hospital 110 to acquire step by step instructions once symptoms appear. It is believed that some patients will need this service, while others will not. While all patients will receive instructions when they acquire the ECG device, it is understandable that once the patient begins to experience the symptoms of ischemia, the patient may become less likely to remember the steps and the process. Also, first time users may feel the need to be given step by step instructions by human interaction.

[0020] Once this call is initiated 110, a trained clinician will instruct the patient 112 on attaching the electrodes 114 and activating the ECG device 116. At this time the process becomes automated. The ECG signals are then acquired 118 and transmitted to the centralized facility 120. Alternatively, if the patient is familiarized with the apparatus and the process 106, 122, the patient attaches the electrodes 124 and activates the ECG device 126, which then begins to acquire the ECG signals 118 from the patient at a location remote from the health care fa-

cility. The ECG device then automatically transmits the ECG signals, or the processed ECG data 120 to the centralized facility, as will be further described with reference to Figs. 3-5. It is noted that the ECG device can transmit either raw ECG signals to be processed later, or it can process the ECG signals and transmit the results of the multi-channel ECG.

[0021] The centralized facility then receives the ECG signals or the ECG processed data 128, and the signals/data are processed at 130. The processing can include either processing the raw ECG signals to produce a graph of the ECG, or simply decoding the transmitted processed ECG data. The trained clinician then analyzes the ECG 132, and if it is clear that there is no cardiac cause for the symptoms 134, 136, the clinician can rule out a cardiac cause for this particular episode 138. The clinician then reassures the patient 140, prints the ECG graph for the patient's file 142 and instructs the patient to disconnect the electrodes 144. The ECG device is then disabled and the process is ended at 146.

[0022] However, if the clinician suspects a cardiac cause for the symptoms the patient is experiencing 134, 148, the clinician can re-evaluate the ECG graph 150 and print the graph 152 for the patient's file while simultaneously activating an automatic repeat feature of the ECG activation and transmission at 154. The clinician then analyzes the new ECG 156 and determines if the cause is cardiac related and if care is needed 158. If the cause is determined not to be cardiac after further ECG acquisitions 158, 160, the clinician can rule out a cardiac cause 138, reassure the patient 140, print and file the ECG 142 and instruct the patient to disconnect the electrodes 144 to end the process 146. On the other hand, if the cause is determined to be cardiac related 158, 162, the clinician determines whether or not critical care is needed 164. If it is not 166, the clinician instructs the patient to go to the patient's health care facility 168. The process then concludes with the patient going to the health care facility 170, 146. Conversely, if it is determined that critical care is necessary immediately 164, 172, the centralized facility dispatches an ambulance 174 to pick up the patient and the system continues to monitor the ECG of the patient at 176 until the patient arrives at the hospital 178, which concludes the process 146.

[0023] Fig. 3 shows a block diagram of one embodiment of the present invention in which a patient 180 is located at a remote location 182. The patient 180 is shown connected to the portable ECG device 184, of the present invention to receive multiple channels of ECG signals from patient 180. The ECG device 184 is coupled to automatically communicate with a wireless communication device, in this case, a cellular or digital mobile phone 186. The mobile phone 186 is connected to the ECG device 184 to receive patient ECG data and to transmit the patient ECG data through electromagnetic waves 188 to a centralized health care facility 190. In this manner, both voice 192 and ECG signals 194 can be communicated in real time, or in very near real time, from the

remote location 182 by electromagnetic waves 188 to the centralized health care facility 190. This transmission, occurring over a single connection, is defined herein as being a concurrent voice and ECG data transmission. The wireless phone 186 can be constructed integral with the ECG device 184, or it can include infrared transmitter and receivers to communicate therebetween.

[0024] The centralized health care facility 190 may be a hospital, a health care provider, or a separate centralized facility providing a service of monitoring and assessing the ECG results for hospitals and health care providers and transmitting the results to the hospital or health care provider 196 through a data line 197. At the centralized facility 190, a local communication interface 198 includes a phone connection to allow voice transmissions 200 with a doctor/clinician 202, who has access to the patient's file or chart 204. The local communication interface 198 is also connected to an ECG and/or an ECG display 206 to process and/or display an ECG graph. The ECG/display 206 is connected to a printer 208 so that the ECG graph can be printed and placed in the patient's file 204. The file 204 may be an electronic chart accessible to the centralized facility 190 and/or a separate health care provider 196 via data line 197. Similarly, the doctor/clinician may communicate directly with the health care provider 196 to alert the health care provider of the results of the ECG. In accordance with the aforementioned process, the doctor/clinician 202 can talk with the patient 180 and observe the patient's ECG waveforms in real time, or in near real time, to assess the patient's condition. Fig. 3 shows one particular embodiment for dividing the functions between a centralized facility 190 and a health care provider 196, however, it is contemplated that multiple different configurations can be arranged, each of which are embodied in the appended claims.

[0025] Referring to Fig. 4, a second embodiment of the present invention is disclosed. Again, patient 180 is connected to the ECG device 184, of the present invention, which preferably includes a 12-channel ECG device, such as the aforementioned GE Marquette MacVu or Seer-MC equipped with 12SL™. However, in this embodiment, the wireless communication device is an interactive Internet appliance such as an interactive Web TV appliance 210, capable of allowing voice, video and ECG data transmission through an interconnected global computer system, such as the Internet 212. The ECG device 184 and the Web TV appliance 210 transmits data therebetween through an infrared transmission 214. Accordingly, the ECG device 184 is equipped with an infrared transmitter and the Web TV appliance is equipped with an infrared receiver, as described with reference to Fig. 1. The Web TV appliance 210 can also receive data instructions from the centralized facility or health care provider 190 through the Web TV appliance 210. The Web TV appliance 210 is connected to a television 216 to display visual signals 218 and audio signals 220 to patient 180.

[0026] Preferably, the Web TV appliance 210 is equipped with a video camera 222 and a microphone 224 to receive and transmit audio and video signals from patient 180 to the centralized facility 190. In this manner, the processor in the ECG device 184 is programmed to allow concurrent transmission of ECG data, voice data, and video data, wherein the video and audio transmissions may be bi-directional. That is, since the voice, video, and ECG signals are communicated in real time, or near real time, from the remote location 182 to the centralized facility 190, which may be a hospital, the centralized facility 190 is thereby equipped with a Web computer 226 that is, in turn, connected to a television 228, also equipped with a microphone 230 and a video camera 232 to transmit images and audio from a doctor or clinician 240. Similar to the embodiment of Fig. 3, the doctor or clinician at the centralized facility 190, Fig. 4, can listen to and talk to the patient 180 remotely while observing the patient's ECG waveforms. Also similar to the embodiment of Fig. 3, the ECG/display 206 receives data from the local communication interface 226. If the data has already been processed, it can go directly to the printer 208, or if the ECG of the centralized facility is processing the data, the signals go through the ECG 206, then to the printer 208. The patient's file is then updated 204.

[0027] Referring to Fig. 5, a detailed flow chart of the software programmed into the portable ECG device is shown. Once the ECG is initiated 250, the program checks to see if the patient requests assistance with using the ECG device 252. If so 254, the auto-dial feature of the mobile phone is initiated or the Web TV interface is prompted 256, at which time communication is permitted between the health care provider, or centralized facility, and the patient 258. Once the assistance is complete 260, or the patient did not require assistance 252, 262, the ECG signals are acquired 264, processed 266, and prepared for transmission at 268. The desired mode of transmission is then selected at 270 to allow concurrent transmission of ECG data and at least voice communication.

[0028] If the Web TV mode is selected 270, 272, the ECG transmits the data to the Web TV device 274 and allows audiovisual communication 276. Conversely, if the wireless phone transmission mode is selected 270, 278, the auto-dial feature is enabled, if not already connected 280, and the ECG transmits the data at 282, thereby allowing bi-directional voice communication 284. At this point, regardless of whether the wireless phone transmission mode is selected 278 or the Web TV mode is selected 272, the ECG device is enabled to receive instructions 286 from the centralized facility. If the ECG is instructed to acquire more data 288, 290 the process is repeated. If not 288, 292, the ECG subroutine is complete 294.

[0029] Accordingly, the present invention includes an ECG monitoring system having a remote ECG monitor with multiple leads and multiple channels to acquire ECG signals from a patient. A remote communication interface

is also provided to receive the ECG signals from the remote ECG monitor and transmit the ECG signals over a public communication system to a health care provider or centralized facility. A local communication interface is provided at the centralized facility to receive ECG signals from the public communication system and is connected to a local ECG device to receive the ECG signals and provide the ECG signals in human discernable form. The ECG signals can be processed and digitally analyzed in either the remote ECG monitor, the remote communication interface, the local communication interface, or the local ECG device. As previously discussed, the remote communication interface can either be a wireless phone or an interactive Internet appliance having a video camera or microphone to allow bi-directional communication between the patient and the health care provider. Although it may be considered redundant, an embodiment may include both.

[0030] The device can also include an information management system that includes a data link port connectable to maintain ECG monitoring during patient transport to a health care facility. The information management system can include a portable computer with data storage that is downloadable at the health care facility for recording the ECG data during transit. The information management system includes a communication system to broadcast ECG data as the patient is in transit to a health care facility.

[0031] The invention also includes a method of remotely monitoring ECG data from a patient that includes providing an ECG device to a patient experiencing symptomatic ischemia for use remotely from a health care facility. The ECG device includes the aforementioned communication capabilities to transmit ECG signals/data to a centralized facility. The method includes acquiring a multi-channel ECG from the patient at a location remote from a health care facility and transmitting the multi-channel ECG data to the centralized facility. After assessing the multi-channel ECG at the centralized facility, the method includes providing instructions to the patient based on the assessment. The method can also include offering remote interactive assistance in the use of the ECG device, if requested by the patient.

[0032] It is contemplated that the method can be conducted by a centralized facility as a service to a health care facility. That is, personnel at the centralized facility can coordinate the ECG monitoring and advise the health care facility as needed. Alternatively, the centralized facility can be integrated with the health care facility. The method also includes repeating the acquiring, transmitting, and assessing steps, as dictated by the centralized facility, or health care provider, and if an ECG assessment results in a determination that immediate medical care is needed, the method includes dispatching emergency personnel to the patient. The method can include continuing, acquiring, transmitting, and assessing the ECG while the patient is in transit to the health care facility.

[0033] With the use of a Web TV appliance, the centralized facility can be relatively assured that the patient is located at the patient's house during use. However, the same cannot be said for the wireless phone transmission mode. In this instance, the method can include confirming a location of the patient before dispatching emergency personnel. This can be done through telephone communication, but if the patient should experience a heart attack and become unconscious, an alternative method must be provided. In this instance, the confirmation step includes receiving a GPS guidance signal from the ECG device indicative of the location of the patient. Accordingly, the ECG device optionally includes a GPS guidance system. The guidance system is initialized by the centralized facility which sends the GPS initialization signal to the ECG device, and once received, the ECG device transmits a GPS guidance signal from the ECG device to a global satellite system, which in turn, transmits a location of the patient to the centralized facility.

Claims

1. A portable ECG device (184) comprising:

an ECG monitor (10) connected to a plurality of lead wires (28), each lead wire having a transducer (30) capable of receiving an ECG signal from a patient (32), the ECG monitor (10) having a processor (38) to process the ECG signals from the plurality of lead wires (28) and produce ECG data (52, 194) representative of a cardiac condition of the patient (32); and a wireless communication interface (50) coupled to receive the patient ECG data (52, 194) from the ECG monitor (10) and to transmit the patient ECG data to a health care provider (190);

characterised in that the processor (38) is programmed to:

prompt the patient (32) if assistance is needed to acquire an ECG, and if so, open a data transmission link to the health care provider (190); otherwise, receive and process the ECG signals, then open a data transmission link via the wireless communication interface to transmit the ECG data to the health care provider (190).

2. The portable ECG device (184) of claim 1 wherein the wireless communication interface (50) is a wireless phone (50, 186) capable of allowing voice (192) and ECG data (194) transmission concurrently.

3. The portable ECG device (184) of claim 1 wherein the wireless communication interface (50) is an interactive Web TV appliance (58, 210) capable of al-

lowing voice, video and ECG data transmission concurrently.

4. An ECG monitor system comprising:

a portable ECG device (184) according to any preceding claim;
 the wireless communication interface (50, 186, 210) transmitting the ECG data (194) over a public communication system (GPS) to the health care provider (190);
 a local communication interface (198, 226) to receive the ECG signals (194) from the public communication system (GPS) at the health care provider (190); and
 a local ECG device (206) connected to the local communication interface (198, 226) to receive the ECG data (194) and provide the ECG data (194) in human discernable form.

5. The system of claim 4 wherein the ECG monitor (10) includes an infrared transmitter to transmit the ECG data (194) to the wireless communication interface (50, 185, 210).

6. The system of claim 4 or 5 wherein the ECG signals are processed and digitally analyzed by the processor (38) of the ECG monitor (10).

7. A method (100) of remotely monitoring ECG data (194) from a patient comprising the steps of:

providing a portable ECG device (184) according to any of claims 1 to 3 to a patient (32, 180) experiencing symptomatic ischemia (104) for use remotely from the health care provider (190), the ECG monitor (10);
 acquiring ECG signals from the patient (32, 180) and producing ECG data;
 transmitting (120) the ECG data from the wireless communication interface to the health care provider (190);
 assessing (132) the ECG data at the health care provider (190); and
 providing instructions (140, 168) to the patient (32, 180) based on the assessment of the ECG data.

8. The method (100) of claim 7 further comprising the step of offering remote interactive assistance (140, 168) in the use of the portable ECG device (184), if requested by the patient.

9. The method (100) of claim 7 wherein the steps of assessing the ECG data and providing instructions are conducted by the health care provider (190) as a service to another health care provider (196).

Patentansprüche

1. Mobiles EKG-Gerät (184), das aufweist :

einen EKG-Monitor (10), der mit einer Anzahl von Kabelverbindungen (28) verbunden ist, wobei jede Kabelverbindung einen Wandler (30) aufweist, der in der Lage ist ein EKG-Signal von einem Patienten (32) zu empfangen, wobei der EKG-Monitor (10) einen Prozessor (38) zum Verarbeiten der EKG-Signale von der Anzahl der Kabelverbindungen (28) aufweist und EKG-Daten (50, 194), die einen Zustand des Herzens des Patienten (32) repräsentieren, erzeugt; und ein drahtlos verbundenes Kommunikationsinterface (50), um die EKG-Daten (52, 194) von dem EKG-Monitor (10) zu empfangen und die EKG-Daten an eine Gesundheitsüberwachungseinrichtung (190) zu übertragen;

dadurch gekennzeichnet, dass der Prozessor (38) programmiert ist:

den Patienten (32) abzufragen, um, wenn Assistenz notwendig ist, ein EKG zu akquirieren, und, wenn dies der Fall ist, eine Datenübertragungsverbindung zu der Gesundheitsüberwachungseinrichtung (190) aufzubauen; ansonsten die EKG-Signale zu empfangen und zu verarbeiten, und dann eine Datenübertragungsverbindung mittels eines drahtlosen Kommunikationsinterfaces zu öffnen, um die EKG-Daten zu der Gesundheitsüberwachungseinrichtung (190) zu übertragen.

2. Mobiles EKG-Gerät (184) gemäß Anspruch 1, worin das drahtlose Kommunikationsinterface (50) ein drahtloses Telefon (50, 186) ist, das gleichzeitig die Übertragung von Stimme (192) und EKG-Daten (194) erlaubt.

3. Mobiles EKG-Gerät (184) gemäß Anspruch 1, worin das drahtlose Kommunikationsinterface (50) ein interaktives Web-TV-Gerät (58, 210) ist, das Stimm-, Video- und EKG-Datenübertragung gleichzeitig erlaubt.

4. EKG-Überwachungs-System, das aufweist:

ein mobiles EKG-Gerät (184) gemäß einem der vorhergehenden Ansprüche, das drahtlose Kommunikationsinterface (50, 186, 210), das die EKG-Daten (194) mittels eines öffentlichen Kommunikationssystems (GPS) zu der Gesundheitsüberwachungseinrichtung (190) überträgt; ein lokales Kommunikationsinterface (198, 226), um die EKG-Signale (194) aus dem öffent-

- lichen Kommunikationssystem (GPS) in der Gesundheitsüberwachungseinrichtung (190) zu empfangen; und ein lokales EKG-Gerät (206), das mit dem lokalen Kommunikationsinterface (198, 226) verbunden ist, um die EKG-Daten (194) zu empfangen und die EKG-Daten (194) in einer vom Menschen erkennbaren Form zur Verfügung zu stellen.
5. System gemäß Anspruch 4, worin der EKG-Monitor (10) einen Infrarot-Übertrager enthält, um die EKG-Daten (194) zu dem drahtlosen Kommunikationsinterface (50, 185, 210) zu übertragen.
6. System gemäß Anspruch 4 oder 5, worin die EKG-Signale durch den Prozessor (38) des EKG-Monitors (10) aufbereitet und digital analysiert werden.
7. Verfahren (100) zum drahtlosen Überwachen von EKG-Daten (194) eines Patienten, das die folgenden Schritte aufweist:
- Bereitstellen eines mobilen EKG-Gerätes (184) gemäß einem der Ansprüche 1 bis 3 für einen Patienten (32, 180) mit symptomatischer Ischämie (104) zur drahtlosen Verwendung durch eine Gesundheitsüberwachungseinrichtung (190), wobei der EKG-Monitor (10) die EKG-Signale des Patienten (32, 180) akquiriert und EKG-Daten erzeugt; Übertragen (120) der EKG-Daten zur Gesundheitsüberwachungseinrichtung (190); Bewerten der EKG-Daten in der Gesundheitsüberwachungseinrichtung (190); und Bereitstellen von Anweisungen (140, 168) an den Patienten (32, 180) auf der Basis der Bewertung der EKG-Daten.
8. Verfahren (100) gemäß Anspruch 7, das ferner den Schritt aufweist, drahtlose interaktive Hilfe (140, 168) bei der Verwendung des mobilen EKG-Gerätes (184) anzubieten, wenn diese von dem Patienten angefordert wird.
9. Verfahren (100) gemäß Anspruch 7, worin die Schritte Bewertung der EKG-Daten und Bereitstellung von Anweisungen durch die Gesundheitsüberwachungseinrichtung (190) als Service für eine andere Gesundheitsüberwachungseinrichtung (196) ausgeführt werden.

Revendications

1. Appareil ECG portable (184) comprenant :
- un moniteur ECG (10) connecté à une pluralité

de fils de dérivation (28), chaque fil de dérivation comportant un transducteur (30) capable de recevoir un signal ECG d'un patient (32), le moniteur ECG (10) ayant un processeur (38) pour traiter les signaux ECG provenant de la pluralité de fils de dérivation (28) et produire des données ECG (52, 194) représentatives d'un état cardiaque du patient (32) ; et une interface de communication sans fil (50) couplée pour recevoir les données ECG du patient (52, 194) du moniteur ECG (10) et pour transmettre les données ECG du patient à un prestataire de soins de santé (190) ;

caractérisé en ce que le processeur (38) est programmé pour :

inviter le patient (32) si une assistance est nécessaire pour acquérir un ECG, et le cas échéant, ouvrir une liaison de transmission de données vers le prestataire de soins de santé (190) ; autrement, recevoir et traiter les signaux ECG, puis ouvrir une liaison de transmission de données, via l'interface de communication sans fil, pour transmettre les données ECG au prestataire de soins de santé (190).

2. Appareil ECG portable (184) selon la revendication 1, dans lequel l'interface de communication sans fil (50) est un téléphone sans fil (50, 186) capable d'autoriser simultanément la transmission de la voix (192) et de données ECG (194).
3. Appareil ECG portable (184) selon la revendication 1, dans lequel l'interface de communication sans fil (50) est un terminal de télévision par Internet interactive (58, 210) capable d'autoriser simultanément la transmission de la voix, de la vidéo et de données ECG.
4. Système de moniteur ECG comprenant :

un appareil ECG portable (184) selon l'une quelconque des revendications précédentes ; l'interface de communication sans fil (50, 186, 210) transmettant les données ECG (194) au prestataire de soins de santé (190) par le biais d'un système de communication public (GPS) ; une interface de communication locale (198, 226) pour recevoir les signaux ECG (194) du système de communication public (GPS) chez le prestataire de soins de santé (190) ; et un appareil ECG local (206) connecté à l'interface de communication locale (198, 226) pour recevoir les données ECG (194) et fournir les données ECG (194) sous une forme compréhensible par les humains.

5. Système selon la revendication 4, dans lequel le moniteur ECG (10) comprend un émetteur infrarouge pour transmettre les données ECG (194) à l'interface de communication sans fil (50, 185, 210). 5
6. Système selon la revendication 4 ou 5, dans lequel les signaux ECG sont traités et analysés numériquement par le processeur (38) du moniteur ECG (10).
7. Procédé (100) de surveillance à distance de données ECG (194) provenant d'un patient comprenant les étapes consistant à : 10
- fournir un appareil ECG portable (184) selon l'une quelconque des revendications 1 à 3 à un patient (32, 180) atteint d'ischémie symptomatique (104) pour être utilisé à distance depuis le prestataire de soins de santé (190), le moniteur ECG (10) acquérant des signaux ECG du patient (32, 180) et produisant des données ECG ; 15 20
- transmettre (120) les données ECG de l'interface de communication sans fil au prestataire de soins de santé (190) ;
- évaluer (132) les données ECG chez le prestataire de soins de santé (190) ; et 25
- fournir des instructions (140, 168) au patient (32, 180) basées sur l'évaluation des données ECG.
8. Procédé (100) selon la revendication 7, comprenant en outre l'étape consistant à offrir une assistance interactive à distance (140, 168) pour l'utilisation de l'appareil ECG portable (184), si le patient le demande. 30
9. Procédé (100) selon la revendication 7, dans lequel les étapes d'évaluation des données ECG et de fourniture d'instructions sont exécutées par le prestataire de soins de santé (190) en tant que service fourni à un autre prestataire de soins de santé (196). 35 40

40

45

50

55

FIG. 1

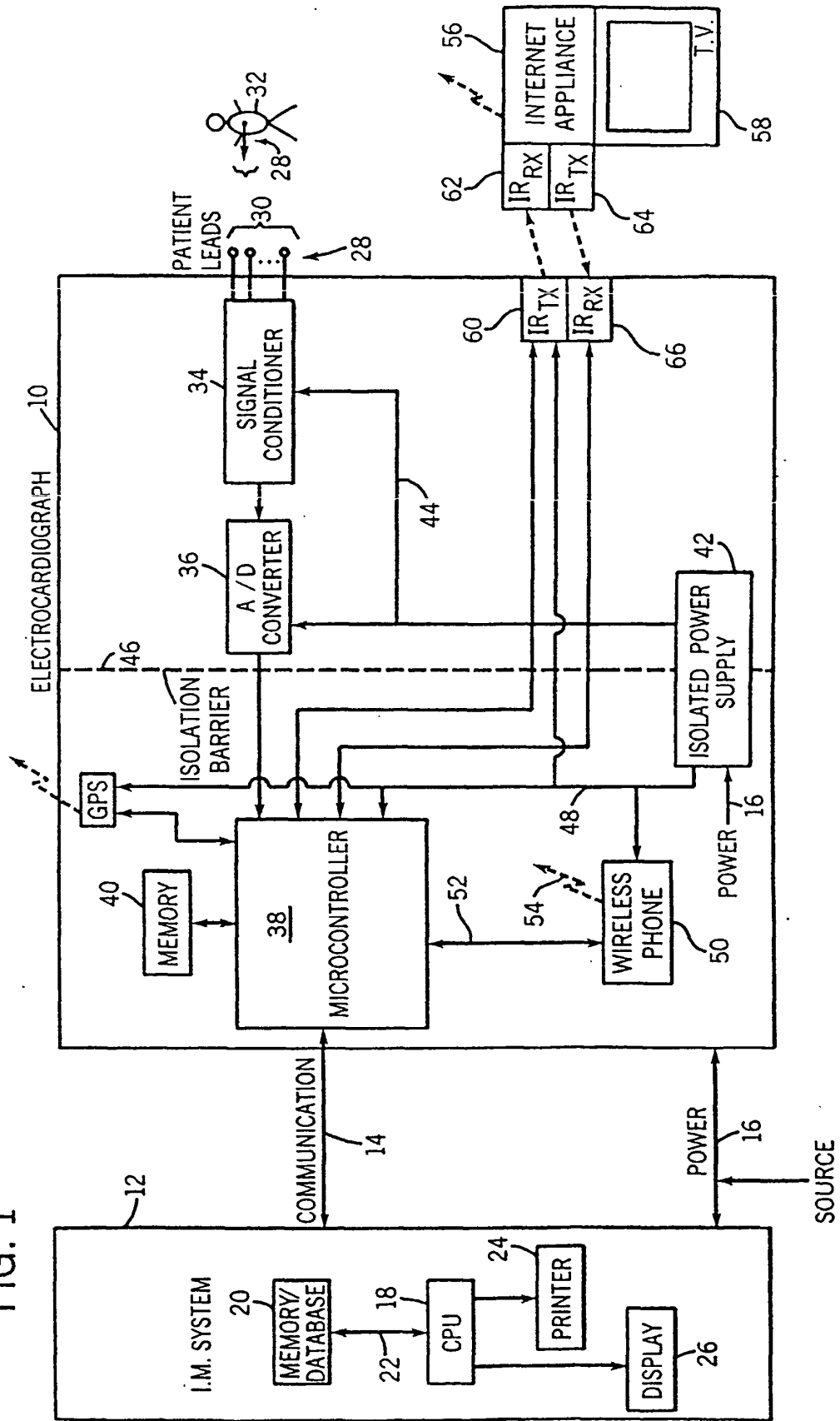
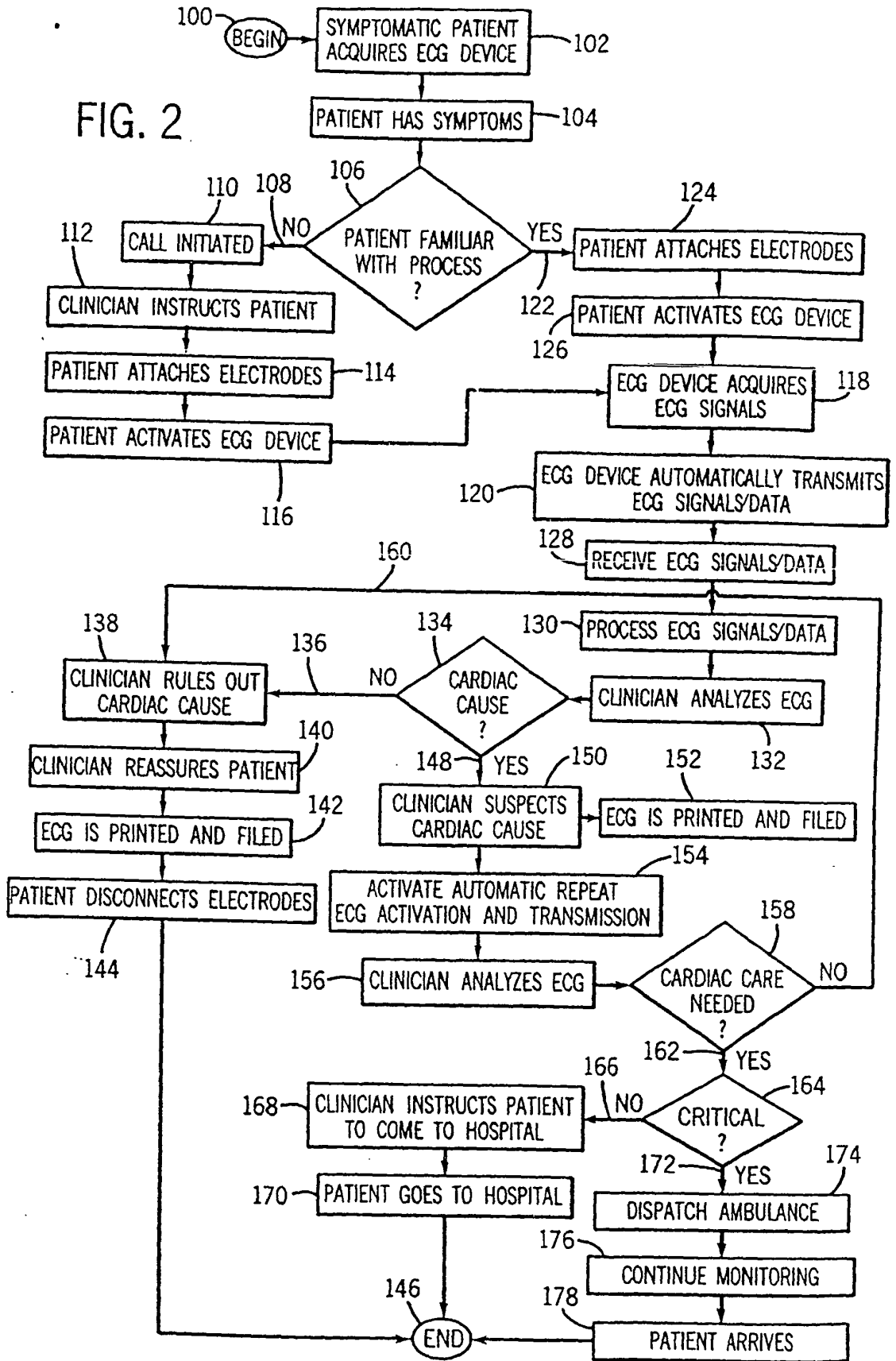

FIG. 2



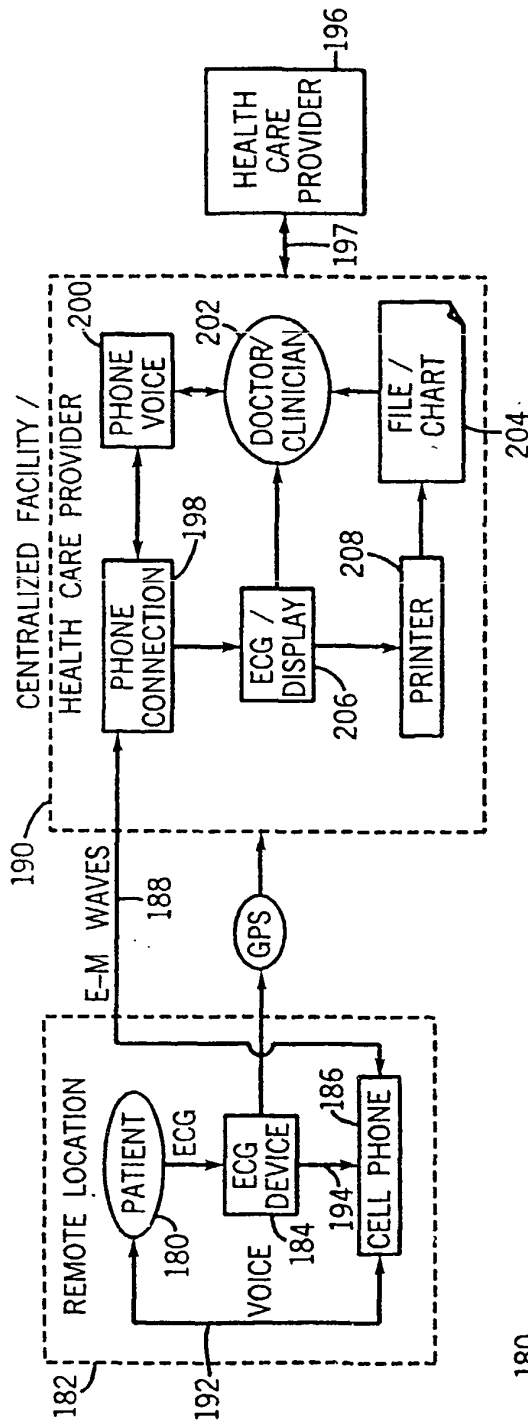

FIG. 3

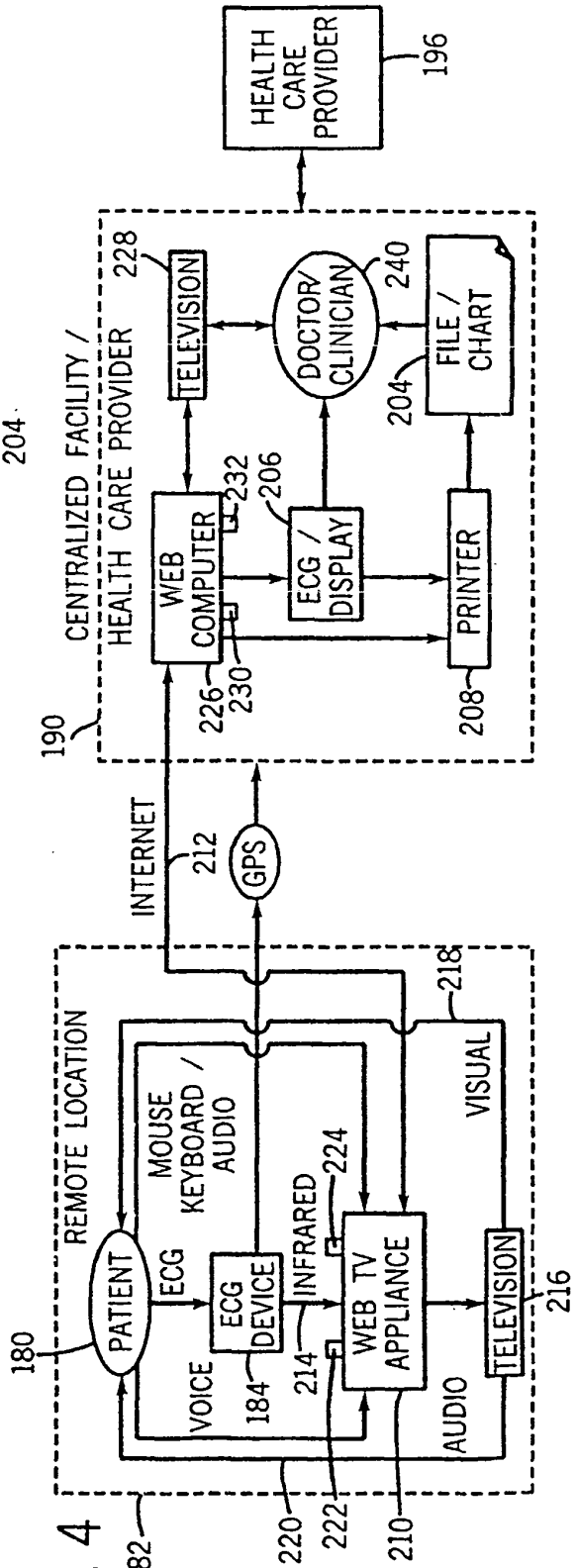
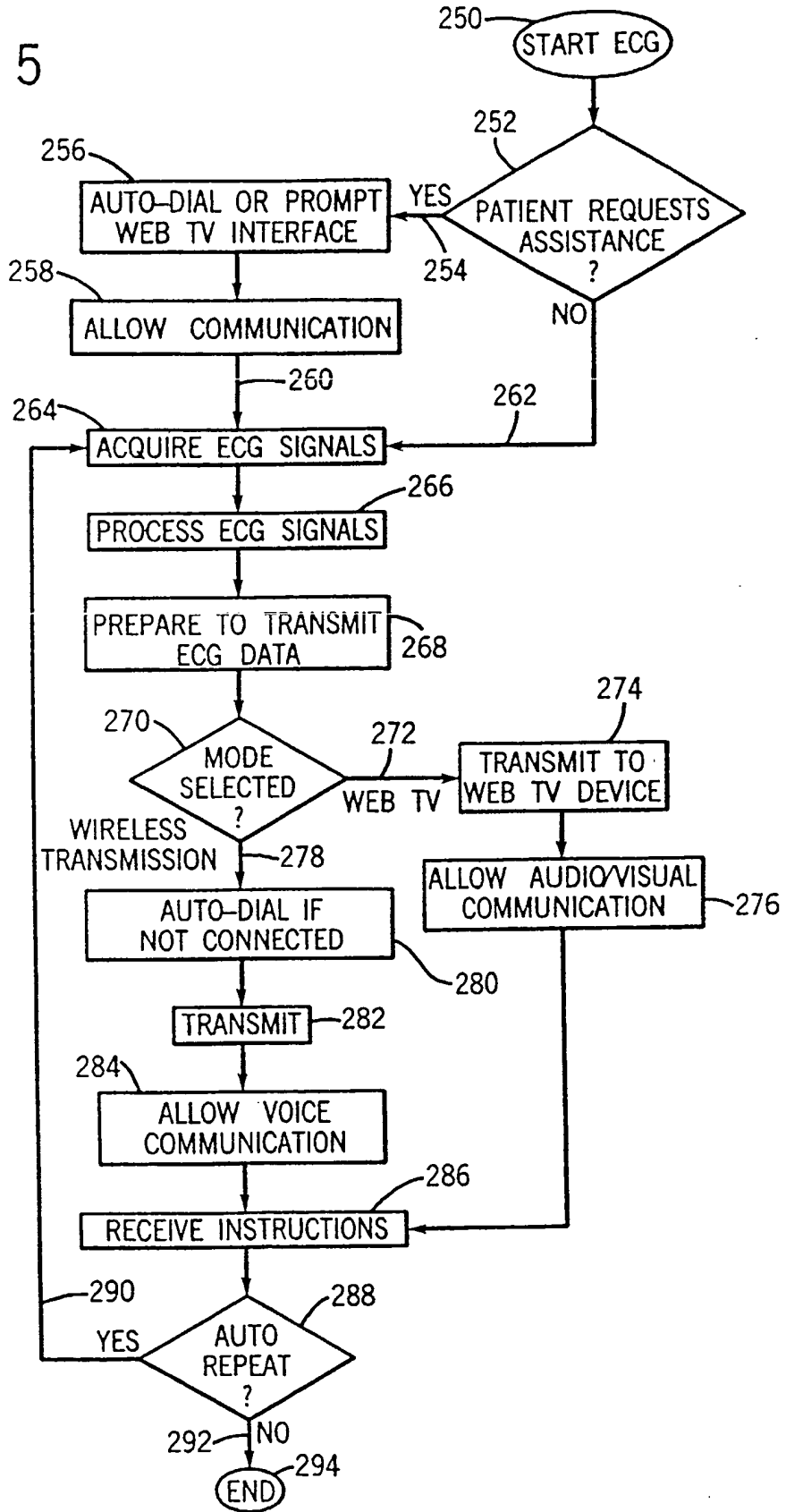

FIG. 4

FIG. 5



专利名称(译)	具有无线通信接口的便携式ECG设备，用于远程监控患者和使用方法		
公开(公告)号	EP1188412B1	公开(公告)日	2007-04-04
申请号	EP2001307734	申请日	2001-09-11
[标]申请(专利权)人(译)	GE医疗系统信息技术公司		
申请(专利权)人(译)	GE医疗系统信息技术股份有限公司.		
当前申请(专利权)人(译)	GE医疗系统信息技术股份有限公司.		
[标]发明人	BRODNICK DONALD EUGENE ROWLANDSON IAN		
发明人	BRODNICK, DONALD EUGENE ROWLANDSON, IAN		
IPC分类号	A61B5/00 A61B5/04 A61B5/0404 H04B7/26 H04M11/00		
CPC分类号	A61B5/0006 G16H40/67 G16H50/20		
优先权	09/661064 2000-09-13 US		
其他公开文献	EP1188412A2 EP1188412A3		
外部链接	Espacenet		

摘要(译)

公开了一种便携式ECG监视器 (184) 和用于远程监视患者 (180) 的心脏功能的整体系统以及使用方法。便携式ECG (184) 包括多引线，多通道ECG监视器和连接到ECG监视器的无线通信设备 (186)，以接收患者ECG数据 (194) 并将患者ECG数据 (194) 发送到集中式设施 (190)，例如医院。无线通信设备可以包括移动电话 (186) 和/或交互式互联网设备。还公开了一种远程监测ECG数据的方法 (194)。该方法包括向这样的患者 (180) 提供具有无线通信 (186) 能力的便携式ECG设备 (184)，在远离医疗机构的位置 (182) 从患者 (180) 获取ECG数据 (194)。(196)，然后将ECG数据 (194) 发送到集中设施 (190)，并评估集中设施 (190) 处的ECG数据 (194)。然后向患者 (180) 提供基于ECG评估的指令。集中设施 (190) 和医疗保健设施 (196) 可以是同一个，或者可以是两个不同且不同的设施。

