

(19)



(11)

EP 3 503 803 B1

(12)

EUROPEAN PATENT SPECIFICATION

(45) Date of publication and mention of the grant of the patent:
27.05.2020 Bulletin 2020/22

(51) Int Cl.:
A61B 5/113 ^(2006.01) **A61B 5/00** ^(2006.01)
A61B 5/087 ^(2006.01) **A61B 5/01** ^(2006.01)

(21) Application number: **17751778.6**

(86) International application number:
PCT/EP2017/070821

(22) Date of filing: **17.08.2017**

(87) International publication number:
WO 2018/036896 (01.03.2018 Gazette 2018/09)

(54) **DEVICE, SYSTEM AND COMPUTER PROGRAM FOR DETECTION OF AN ASTHMA ATTACK OR ASTHMA OF A SUBJECT**

VORRICHTUNG, SYSTEM UND COMPUTERPROGRAMM ZUR ERKENNUNG EINES ASTHMAANFALLS ODER VON ASTHMA EINER PERSON

DISPOSITIF, SYSTÈME ET PROGRAMME D'ORDINATEUR DE DÉTECTION D'UNE ATTAQUE D'ASTHME OU DE L'ASTHME D'UN SUJET

(84) Designated Contracting States:
AL AT BE BG CH CY CZ DE DK EE ES FI FR GB GR HR HU IE IS IT LI LT LU LV MC MK MT NL NO PL PT RO RS SE SI SK SM TR

(30) Priority: **23.08.2016 EP 16185302**

(43) Date of publication of application:
03.07.2019 Bulletin 2019/27

(73) Proprietor: **Koninklijke Philips N.V. 5656 AG Eindhoven (NL)**

(72) Inventors:
 • **MENA BENITO, Maria, Estrella 5656 AE Eindhoven (NL)**
 • **KIRENKO, Ihor, Olehovych 5656 AE Eindhoven (NL)**
 • **AARTS, Ronaldus, Maria 5656 AE Eindhoven (NL)**

(74) Representative: **Tassignon, Tom Philips International B.V. Intellectual Property & Standards High Tech Campus 5 5656 AE Eindhoven (NL)**

(56) References cited:
US-A1- 2012 289 850 US-A1- 2015 265 187
US-A1- 2016 206 216

- **PEREIRA CARINA BARBOSA ET AL: "Remote monitoring of breathing dynamics using infrared thermography.", BIOMEDICAL OPTICS EXPRESS, vol. 6, no. 11, 1 November 2015 (2015-11-01), pages 4378-4394, XP002766331, ISSN: 2156-7085**
- **MURTHY JAYASIMHAN ET AL: "Thermal infrared imaging: a novel method to monitor airflow during polysomnography.", SLEEP, vol. 32, no. 11, November 2009 (2009-11), pages 1521-1527, XP002766332, ISSN: 0161-8105**
- **FEI J ET AL: "Analysis of breathing air flow patterns in thermal imaging", CONFERENCE PROCEEDINGS. ANNUAL INTERNATIONAL CONFERENCE OF THE IEEE ENGINEERING IN MEDICINE AND BIOLOGY SOCIETY (IEEE CAT. NO. 06CH37748) IEEE PISCATAWAY, NJ, USA, 2006, pages 946-952, XP002766333, ISSN: 1557-170X, DOI: 10.1109/IEMBS.2006.260117 ISBN: 1-4244-0032-5**
- **DIXIT, VIKAS MITTAL, YUVRAJ SHARMA: "Voice Parameter Analysis for the disease detection", IOSR JOURNAL OF ELECTRONICS AND COMMUNICATION ENGINEERING (IOSR-JECE), vol. 9, no. 3, June 2014 (2014-06), pages 48-55, XP002767743, ISSN: 2278-8735**

EP 3 503 803 B1

Note: Within nine months of the publication of the mention of the grant of the European patent in the European Patent Bulletin, any person may give notice to the European Patent Office of opposition to that patent, in accordance with the Implementing Regulations. Notice of opposition shall not be deemed to have been filed until the opposition fee has been paid. (Art. 99(1) European Patent Convention).

- **KHUSHBOO BATRA, SWATI BHASIN, AMANDEEP SINGH: "Acoustic Analysis of voice samples to differentiate Healthy and Asthmatic persons", INTERNATIONAL JOURNAL OF ENGINEERING AND COMPUTER SCIENCE, vol. 4, 7 July 2015 (2015-07-07), pages 13161-13164, XP002767744, ISSN: 2319-7242**

Description

FIELD OF THE INVENTION

[0001] The present invention relates to a device, system and computer program for detection of an asthma attack or asthma of a subject.

BACKGROUND OF THE INVENTION

[0002] Asthma is an inflammatory disease of the lungs. It makes breathing difficult and brings on attacks of coughing, wheezing, tightness in the chest and shortness of breath. According to the Centers for Disease Control and Prevention (CDC), approximately 25 million Americans suffer from asthma. It is the most common chronic condition among American children. About one in every 10 children has asthma.

[0003] Bronchial asthma is a multifactorial disease in which environmental, infectious, allergic, and psychological elements all play a part. This complex, multidimensional condition affects patients in many ways. Having asthma is inherently stressful and psychological problems are common and associated with poor asthma outcomes.

[0004] Although most patients in clinical trials can achieve high levels of control with optimized pharmacotherapy, in "real-life" practice, poor control is common, with over-reliance on rescue bronchodilator medication and ongoing symptoms and quality-of-life impairment. Asthma's increasing prevalence, severity and associated medical costs have triggered interest in new physiological and psychological intervention strategies including self-management, breathing-exercise techniques and mental relaxation.

[0005] An asthma attack can be terrifying for both children and adults. For people with asthma, having an "asthma management plan" is the best strategy to prevent an asthma attack. Effective self-management practices to control asthma symptoms and prevent flare-ups are known. These strategies include regular treatment with anti-inflammatory medication, regular medical review, and provision of support for people with asthma to self-regulate their asthma treatment and health related behaviors. Effective self-management practices include self-monitoring of asthma symptoms and/or lung function, medication adherence, and ownership of asthma action plans.

[0006] Prediction of an asthma attack is based on recognizing early warning signs, however sometimes it is not possible or reliable. Earlier, the only way to detect impending asthma attacks in advance was to conduct expensive pulmonary examinations. The best way to predict asthma attacks is to use a peak flow meter regularly and record the readings.

[0007] Many studies have focused just on physiological health even when an intervention has both physiological and psychological components. Stress and psy-

chological factors have been shown by a growing body of evidence to trigger and exacerbate asthmatic conditions. Whatever precipitates an asthmatic attack, anxiety is likely to accompany it. For example, asthmatic children have been described as reacting to stressful situations and emotional distress in terms of anxiety, depression, and irritability. Furthermore, almost one-third of all children with asthma meet the criteria for comorbid anxiety disorders meaning that stress should be viewed as both a trigger and a consequence of this chronic disease. Relaxation training and relaxation techniques have been shown to make positive contributions to asthma management.

[0008] Asthma's increasing prevalence, severity and associated medical costs have triggered interest in new physiological and psychological intervention strategies including self-monitoring and self-management. Effective self-management practices include self-monitoring of asthma symptoms and /or lung function and ownership of asthma action plans. Self-monitoring of asthma is based on prediction and recognition of early warning signs. Unfortunately, sometimes it is not possible or reliable.

[0009] Asthma guidelines include pharmacotherapy strategy, but more and more physicians encourage the use of breathing-exercise techniques and mental relaxation for dealing with asthma. Many patients are interested in non-pharmacological treatments to improve asthma control, particularly breathing control exercises. A problem for many clinicians and patients is accessing therapists who can provide this training. Currently many patients who are interested in this type of treatment can only access it by paying unregulated therapists or by self-help books, internet pages or videos of unknown efficacy. Hence, there is a need for non-pharmacological approach to (self-) manage asthma and prevent serious asthma attacks.

[0010] US 9,131,902 B2 discloses apparatus and methods for predicting an onset of a clinical episode. The apparatus includes a sensor, configured to sense at least one parameter of a subject substantially continuously during a period having a duration of at least one hour, and a control unit, configured to predict, at least one hour prior to the onset of the clinical episode, the onset at least in part responsively to the sensed parameter. Other applications are also described. The disclosed idea is based on using motion and other (non-camera) sensors for extraction of heart rate, respiration rate, motion and body temperature, performs an analysis of long term (at least one hour) pattern of heart rate, respiration rate, and compares it with the "normal" patterns to predict the offsets.

[0011] PEREIRA CARINA BARBOSA ET AL: "Remote monitoring of breathing dynamics using infrared thermography" BIOMEDICAL OPTICS EXPRESS 1 NOV 2015, vol. 6, no. 11, 1 November 2015 (2015-11-01), pages 4378-4394, ISSN: 2156-7085 discloses remote monitoring of breathing dynamics using infrared thermography. In particular, D1 presents a new robust algo-

rhythm to remotely monitor breathing rate by thermal imaging. This approach permits to detect and to track the region of interest as well as to estimate breathing rate.

[0012] FEI J ET AL: "Analysis of breathing air flow patterns in thermal imaging", CONFERENCE PROCEEDINGS. ANNUAL INTERNATIONAL CONFERENCE OF THE IEEE ENGINEERING IN MEDICINE AND BIOLOGY SOCIETY (IEEE CAT. NO. 06CH37748) IEEE PISCATAWAY, NJ, USA, 2006, page 7 pp, ISBN: 1-4244-0032-5 discloses a methodology to characterize breathing patterns based on thermal infrared imaging. The system disclosed is used to record the radiation information from within the breathing flow region. The method opens the way for desktop, unobtrusive monitoring of human respiration.

[0013] US 2016/206216 A1 discloses a device, system and method for skin detection. To enable a reliable, accurate and fast detection the proposed device comprises a thermal sensor input for obtaining thermal sensor data of a scene, a light sensor input for obtaining light sensor data of the scene, and an evaluation unit for analyzing the obtained thermal sensor data and the obtained light sensor data and for detecting skin areas within the scene based on said analysis.

SUMMARY OF THE INVENTION

[0014] It is an object of the present invention to provide a device, system and method for detection of an asthma attack or asthma of a subject allowing (self-) management of asthma and prevention of serious asthma attacks.

[0015] In a first aspect of the present invention a device for detection of an asthma attack or asthma of a subject is presented, said device comprising

- a light sensor input for obtaining light sensor data of the scene, said light sensor data comprising images in the visible and/or infrared light spectrum,
- a thermal sensor input for obtaining thermal sensor data of a scene including a subject while breathing, said thermal sensor data comprising thermal images in the longwave infrared spectrum, and
- an analysis unit for deriving respiratory effort information indicating respiratory efforts of the subject from the obtained light sensor data and for deriving airflow information indicating airflow during respiration of the subject from the obtained thermal sensor data and for predicting or detecting an asthma attack or asthma based on analysis of the respiratory effort information and the airflow information, said analysis evaluating deviations from predetermined or healthy correlations between respiratory efforts and airflow.

[0016] In a further aspect of the present invention a system for detection of an asthma attack or asthma of a subject is presented, said system comprising

- a light sensor for acquiring light sensor data of the scene, said light sensor data comprising images in the visible and/or infrared light spectrum,
- a thermal sensor for acquiring thermal sensor data of a scene, said thermal sensor data comprising thermal images in the longwave infrared spectrum, and
- a device as disclosed herein for detection of an asthma attack or asthma of a subject based on the acquired light sensor data and the acquired thermal sensor data.

[0017] In yet a further aspect of the present invention, there is provided a computer program which comprises program code means for causing a computer to perform the steps of the method disclosed herein when said computer program is carried out on a computer as well as a non-transitory computer-readable recording medium that stores therein a computer program product, which, when executed by a processor, causes the method disclosed herein to be performed.

[0018] Preferred embodiments of the invention are defined in the dependent claims. It shall be understood that the claimed computer program has similar and/or identical preferred embodiments as the claimed system, in particular as defined in the dependent claims and as disclosed herein.

[0019] The present invention is based on the idea to make use of the advantages of light sensor data (e.g. RGB camera data) and thermal sensor data (e.g. infrared camera data) to provide a reliable device, system and method for helping to recognize, control and manage asthma attacks and asthma in general. The sensor data may be acquired by a vital signs camera, as generally known in the field of remote photoplethysmography (rPPG) for unobtrusively and remotely acquiring vital signs of a subject. The advantages of such a vital signals camera can thus be combined with the effectiveness of a biofeedback-assisted personalized relaxation system. Those can be technologies that facilitate effective self-management practices (e.g. personal devices to self-monitor, platform systems for control asthma) and support patients to provide best practice asthma care.

[0020] With the present invention it may be possible to estimate the probability of developing an asthma attack and subsequently to provide biofeedback-assisted personalized treatment to the asthma patient. This could help to contribute to a personal way to manage asthma, and also to prevent serious asthma attacks that potentially require treatment in a hospital.

[0021] Camera-based monitoring of respiration and the acquisition of respiratory effort information indicating respiratory efforts of the subject can be provided in multiple ways. For instance, by using a thermal camera, breathing can be measured by monitoring changes of air temperature around nose or mouth. Moreover, by analyzing specific movements of a chest and/or a belly, breathing efforts can be measured, and the breathing rate can be extracted. By combining two sensor (e.g.

camera) modalities (thermal and 2D motion), the combined analysis of the effort and airflow (indicating efficiency) of breathing can be achieved. These data can then be evaluated to reliably predict or detect an asthma attack or asthma.

[0022] Compared to the apparatus and methods disclosed in US 9,131,902 B2, the device, system and method according to the present invention uses a different sensor (preferably camera) modalities (contrary to contact sensors) for remotely monitoring of several pieces of information simultaneously. Further, deviations, in particular instantaneous deviations, from predetermined or healthy correlations between an airflow (detected from the thermal sensor data) and respiratory efforts (detected by the light sensor data; optionally in addition by the thermal sensor data) may be identified to detect mismatches for predicting or detecting an asthma attack or asthma, i.e. no long term patterns of respiration rate are required.

[0023] In another embodiment said analysis unit is configured to evaluate, in the obtained light sensor data, motion of a body part, in particular the chest and/or belly portion, of the subject caused by respiration to derive the respiratory effort information. This provides an efficient way of obtaining the respiratory effort information, e.g. from camera data as light sensor data.

[0024] The analysis unit may further be configured to estimate a stress level of the subject from the obtained light sensor data and/or the obtained thermal sensor data and to take the estimated stress level into account in predicting or detecting an asthma attack or asthma. For instance, one or more vital signs, in particular heart rate and/or heart rate variability, of the subject may be determined from the obtained light sensor data and/or the obtained thermal sensor data to estimate a stress level of the subject. This information may also be used to check whether stress (e.g. detected from heart rate variability) is the reason for an asthma attack.

[0025] The device may further comprise an audio input for obtaining speech data of the subject representing speech of the subject, wherein said analysis unit is configured to estimate a stress level and/or derive respiratory information of the subject from the obtained speech data and to take the estimated stress level and/or the derived respiratory information into account in predicting or detecting an asthma attack or asthma. Thus, the efforts of the subject to speak loudly may be observed and evaluated.

[0026] The audio input may be configured to obtain speech data representing speech of the subject reading a text, in particular a predetermined text, wherein said analysis unit may be configured to derive reading information indicating reading difficulties and to take the derived reading information into account in predicting or detecting an asthma attack or asthma. If a person is not able to speak more than short phrases due to shortness of breath, or respiratory rate is increased significantly, that would indicate the beginning of the asthma attack. The severity of the attack can be evaluated objectively

by analyzing the amount of breathing efforts, and/or the complexity of the text on which the person starts to experience problems with reading loudly.

[0027] Further, in an embodiment said analysis unit may be configured to derive air temperature change information indicating air temperature changes around mouth and/or nose of the subject from the obtained thermal sensor data and to take the derived air temperature change information into account in predicting or detecting an asthma attack or asthma. By measuring air temperature changes around mouth and nose breathing information can be easily obtained from the thermal sensor data.

[0028] The device may further comprise an output unit for issuing feedback information indicating feedback about a result of the detection and/or guidance information indicating guidance about actions to be performed to the subject. This supports self-management, treatment and/or prevention of an asthma attack.

[0029] Still further, the device may further comprise a data input for obtaining environmental data indicating the environment of the subject and/or medication data indicating medication, in particular allergens, administered to the subject, wherein said analysis unit is configured to take the obtained environmental data and/or the obtained medication data into account in predicting or detecting an asthma attack or asthma. This may particularly help to understand if an asthma event may be caused by a certain reason or if there is no real asthma event, but e.g. an allergic reaction caused by a medication or an environmental situation.

[0030] As explained above, the proposed system comprises a thermal sensor and a light sensor. The thermal sensor may comprise a longwave camera unit for acquiring thermal images in the longwave infrared spectrum. The light sensor may comprise an imaging unit for acquiring images in the visible and/or infrared light spectrum. The system may further comprise one or more of a microphone for generating speech data representing the speech of the subject, an environmental sensor for generating environmental data indicating the environment of the subject and/or a medication unit for generating medication data indicating medication, in particular allergens, administered to the subject.

[0031] According to an aspect a method for enabling detection of an asthma attack or asthma of a subject is presented, said method comprising:

- obtaining light sensor data of the scene, said light sensor data comprising images in the visible and/or infrared light spectrum,
- obtaining thermal sensor data of a scene including a subject while breathing, said thermal sensor data comprising thermal images in the longwave infrared spectrum,
- deriving respiratory effort information indicating respiratory efforts of the subject from the obtained light sensor data,
- deriving airflow information indicating airflow during

respiration of the subject from the obtained thermal sensor data, and

- analyzing the respiratory effort information and the airflow information by evaluating deviations from predetermined or healthy correlations between respiratory efforts and airflow allowing to predict or detect an asthma attack or asthma based on said analysis.

[0032] The result of the evaluation of the deviations enables a practitioner, e.g. a doctor, to predict or detect an asthma attack or asthma. In an embodiment of the method the result of the evaluation of the deviations may additionally be used to automatically predict or detect an asthma attack or asthma.

BRIEF DESCRIPTION OF THE DRAWINGS

[0033] These and other aspects of the invention will be apparent from and elucidated with reference to the embodiment(s) described hereinafter. In the following drawings

Fig. 1 shows a schematic diagram of a first embodiment of a device and a system according to the present invention,

Fig. 2 shows a schematic diagram of a second embodiment of a device and a system according to the present invention, and

Fig. 3 shows a schematic diagram of a third embodiment of a device and a system according to the present invention.

DETAILED DESCRIPTION OF THE INVENTION

[0034] Fig. 1 shows a schematic diagram of a first embodiment of a device 10 and a system 1 according to the present invention. According to this embodiment the system 1 comprises a light sensor 20, e.g. a video camera (such as an RGB camera), for acquiring light sensor data 21 of the scene, a thermal sensor 30, e.g. an infrared camera, for acquiring thermal sensor data 31 of a scene, and a device 10 detection of an asthma attack or asthma of a subject based on the acquired light sensor data 21 and the acquired thermal sensor data 31.

[0035] The device 10 comprises a light sensor input 11, e.g. a wireless or wired interface for connection with the light sensor 20, for obtaining the light sensor data 21 of the scene and a thermal sensor input 12, e.g. a wireless or wired interface for connection with the thermal sensor 30, for obtaining the thermal sensor data 31 of the scene including a subject while breathing. The device 10 further comprises an analysis unit 13, e.g. a processor, for deriving respiratory effort information indicating respiratory efforts of the subject from the obtained light sensor data and/or the obtained thermal sensor data and for deriving airflow information indicating airflow during respiration of the subject from the obtained thermal sensor data and

for predicting or detecting an asthma attack or asthma based on analysis of the respiratory effort information and the airflow information.

[0036] The device 10 and the corresponding method may be implemented in hard- and/or software, e.g. on a computer or processor loaded with corresponding software (e.g. an application ('app')). For instance, a user device comprising a processor, such as a smartphone, tablet, laptop, PC, glasses, goggles (like a Google Glass-type of device) or wristwatch, may implement the device so that the user directly obtains the result of the detection, e.g. as feedback on the screen of the user device. In other embodiments the device 10 may be implemented as dedicated device specifically configured for the purpose of detecting an asthma attack or asthma of a subject.

[0037] In a practical implementation, the thermal sensor 30 comprises a longwave camera unit for acquiring thermal images in the longwave infrared spectrum and the light sensor 20 comprises an imaging unit, such as an RGB camera or an IR camera, for acquiring images in the visible and/or infrared (IR) light spectrum. If such a camera (or a vital signs camera as used in the field of remote photoplethysmography (rPPG)) is used as light sensor 20, various vital signs may be remotely acquired by use of the commonly known technique of rPPG, such as respiration rate, breathing patterns and (optionally) heart rate, which may be used separately or which may be evaluated by the analysis unit 13.

[0038] Fig. 2 shows a schematic diagram of a second embodiment of a device 10a and a system 2 according to the present invention. In this embodiment the system 2 further a microphone 40 for generating speech data 41 representing the speech of the subject 100. The device 10a comprises a corresponding audio input 14 for obtaining said speech data and providing them to the analysis unit 13, where the speech data are additionally used for predicting asthma or an asthma attack.

[0039] In an embodiment, a stress level is estimated and/or respiratory information of the subject is derived from the obtained speech data 41 and the estimated stress level and/or the derived respiratory information is taken into account in predicting or detecting an asthma attack or asthma.

[0040] In another embodiment the speech data 41 represent speech of the subject 100 reading a text, in particular a predetermined text. The analysis unit 13 may then derive reading information indicating reading difficulties and to take the derived reading information into account in predicting or detecting an asthma attack or asthma.

[0041] The microphone 40 can further record breathing signals, detect coughs and wheezing, which information may additionally be evaluated by the analysis to further improve the prediction of asthma or asthma attacks.

[0042] The proposed device, system and method enable an evaluation of the possibility of developing asthma attack or estimate the severity of the attack. In an em-

bodiment the subject 100 may be asked to undergo a set of tests, which involves breathing according to various breathing pattern and reading a certain text. For the first part of the test, a person is asked to follow respiratory patterns with various depths, frequency and type (chest vs. abdomen) of breathing. During this test, 2D and thermal camera-based monitoring is performed to analyze the correlation between the respiratory effort that a person has to take and the efficiency of breathing (amount of airflow) detected by a thermal camera. In the second part of the test, the person is asked to read loudly the sentences with increasing complexity. Meanwhile, the camera unit (including the 2D camera, as an embodiment of the light sensor 20) and/or the thermal camera (as an embodiment of the thermal sensor 30) and an audio microphone 40 monitor the efforts a person has to put to read loudly the complex text. If a person is not able to speak more than short phrases due to shortness of breath, or respiratory rate is increased significantly, that would indicate the beginning of the asthma attack. The severity of the attack can be evaluated objectively by analyzing the amount of breathing efforts and/or the complexity of the text on which the patient starts to experience problems with reading loudly.

[0043] All data is collected by the device (which may e.g. be configured as a smartphone, tablet, laptop, glasses, goggles (like a Google Glass-type of device), etc., in general as a user device), and may additionally be issued via an output unit 15, as shown in Fig. 2 as part of the device 10a, as feedback information indicating feedback about a result of the detection. Further, guidance information indicating guidance about actions to be performed to the subject 100 may be issued via the output unit 15. The output unit 15 may, for instance, be configured as user interface, e.g. as display or touchscreen. In another embodiment, the output unit 15 may be configured as transmission unit, e.g. for wireless (or wired) data transmission, preferably in real time, for instance using a WiFi network, a communication network, Bluetooth, Zigbee, or any other data transmission technique, to another entity, such as the subject's PC, a caregiver's PC or handheld device, a hospital workstation or archive, etc. For instance, the device 10a can be connected to an electronic health record of a hospital and may be able to send relevant information to a doctor, such as an asthma specialist at the hospital. This information can help to provide a more correct and feasibility diagnosis. This can be especially beneficial for those patients living in regional, rural and remote areas.

[0044] The complete multimodal system may thus be regarded as a biofeedback-assisted personalized relaxation system. The biofeedback-assisted personalized relaxation system may comprise a guided breathing exercise to reduce the stress level (as a possible source of the asthma attack) and the sensors to collect the information on the changes in respiratory effort, respiratory flow, and optionally Heart Rate Variability (HRV) measured by camera-based methods. Further, the collected

information may be analyzed to monitor whether the personalized relaxation exercise makes a positive impact and whether stress was a major source of the asthma attack.

[0045] In a further embodiment, as also shown in Fig. 2, an environmental sensor 50 for generating environmental data 51 indicating the environment of the subject and/or a medication unit 60 for generating medication data 61 indicating medication, in particular allergens, administered to the subject may be provided. Accordingly, the device 10a further comprises a data input 16 for obtaining the environmental data 51 and/or the medication data 61.

[0046] The environmental data 51 may e.g. include data about the surrounding of the subject, such as air pollution, pollen, etc. The environmental sensor 50 could thus include a sensor that collects such environmental data, such as an air pollution sensor, pollen sensor, etc.

[0047] The device 10a is thus able to monitor the environmental situation of the asthma patient and consequently estimating the probability that triggers can activate asthma attack and therefore helping to avoid asthma attack.

[0048] The medication data 61 may e.g. include information about the kind, dose, timing, etc. of medication, in particular allergens, administered to the subject, which may have an influence on the subject's health, i.e. which particularly contribute to causing asthma or an asthma attack or which may be the source of the subject's condition looking like an asthma attack but being in fact a different reaction, e.g. an allergic reaction of the subject 100 in response to a certain medication. The medication unit 60 could thus be a unit where information about the medication is entered by a user or a medication dispenser which automatically registers dispensed medication. The device 10a can thus improve the reliability by monitoring the amount of e.g. allergen materials applied and therefore helping to avoid inappropriate or incorrect diagnosis for the individual patient, but also a much more feasible way in the comparison of patch test results.

[0049] The analysis unit 13 is thus preferably configured to take the obtained environmental data 51 and/or the obtained medication data 61 into account in predicting or detecting an asthma attack or asthma.

[0050] Fig. 3 shows a schematic diagram of a third embodiment of a device 10b and a system 3 according to the present invention. Fig. 3 shows particularly more details of an embodiment of the processing chain for the prediction of the asthma attack and evaluation of its severity.

[0051] This embodiment of the proposed system 3 comprises three main elements:

- Registration of the breathing pattern condition on normal state: objective baseline estimation and comparison of breathing pattern to the registered baseline.
- Real-time guidance on evolution: personalized bio-

feedback.

- Spot-check or continuous monitoring of breathing rate during onset.

[0052] The system 3 comprises at least a set of cameras 20, 30 or a camera unit integrating these cameras 20, 30 for 2D and thermal image acquisition and an audio microphone 40, the data of which are used for predicting the probability of having an asthma attack and for estimating its severity.

[0053] The analysis unit 13 can evaluate when an asthma suffer is close to have an asthma attack by combined analysis of heat flow during breathing and respiratory effort. For this purpose the analysis unit 13, in this embodiment, comprises a motion analysis unit 130 for analyzing motion in the light sensor data 21 (in this case 2D image data) and respiratory effort estimation unit 131 for estimating the respiratory effort from the analyzed motion. From the 2D image data it is further possible to analyze the subject's breathing pattern (chest or belly breathing), respiratory rate, respiratory effort and the air flow, which information may also be evaluated for the final prediction and detection.

[0054] A heat flow analysis unit 132 is provided for analyzing heat flow from the thermal sensor data 31 and an air flow estimation unit 133 for estimating the respiratory air flow from the analyzed heat flow. In a breathing efficiency analysis unit 134 the estimated respiratory effort and the estimated air flow are analyzed to obtain information on the breathing efficiency.

[0055] Moreover, the analysis unit 13 comprises a voice analysis unit 135 for analyzing the speech data 41 of the subject, e.g. to detect the disruption of a speech during a stimulus (e.g. reading a complex text loudly). Further, a stress level estimation unit 136 is provided for estimating the stress level of the subject during the stimulus based on the analysis of the speech data.

[0056] A prediction unit 137 is provided for detecting or predicting asthma or an asthma attack and/or for estimating the severity/level of an asthma attack based on the result of the prior analyses.

[0057] In an embodiment a display may be provided, as an output unit 15 (as shown in Fig. 2) to show the breathing patterns, which should be followed by a subject during a personalized relaxation exercise.

[0058] The proposed way of analysis automatically performed by the device has the advantages of being much easier to use for asthma patients compared to the actual ways to predict asthma attacks. The optionally provided relaxation exercise helps to normalize the breathing patterns to a monitored base line. On the basis of this deviation, the device can decide if the relaxation exercise needs to be activated. Further on, the device can finalize the relaxation exercise when it estimates that the breathing rate is controlled and consequently the asthma episode is over. Additionally, the proposed device can provide help to adopt a slower respiratory rate with longer expiration and reduction in overall ventilation. This can

be done at the onset of and/or during asthma attacks.

[0059] The present invention thus provides a self-monitoring system, device and method having several advantages, including allowing patients to analyze their breath themselves and also helping to be less anxious of having an asthma attack. The device, system and method according to the present invention are aimed to be used for self-monitoring, control and management of asthma attacks and asthma in general. Further, they can be used for people suffering for hyperventilation or for those experience breathing problems, i.e. while suffering from influenza.

[0060] While the invention has been illustrated and described in detail in the drawings and foregoing description, such illustration and description are to be considered illustrative or exemplary and not restrictive; the invention is not limited to the disclosed embodiments. Other variations to the disclosed embodiments can be understood and effected by those skilled in the art in practicing the claimed invention, from a study of the drawings, the disclosure, and the appended claims.

[0061] In the claims, the word "comprising" does not exclude other elements or steps, and the indefinite article "a" or "an" does not exclude a plurality. A single element or other unit may fulfill the functions of several items recited in the claims. The mere fact that certain measures are recited in mutually different dependent claims does not indicate that a combination of these measures cannot be used to advantage.

[0062] A computer program may be stored/distributed on a suitable non-transitory medium, such as an optical storage medium or a solid-state medium supplied together with or as part of other hardware, but may also be distributed in other forms, such as via the Internet or other wired or wireless telecommunication systems.

[0063] Any reference signs in the claims should not be construed as limiting the scope.

40 Claims

1. Device (10, 10a, 10b) for detection of an asthma attack or asthma of a subject, said device comprising:

- a light sensor input (11) for obtaining light sensor data of the scene, said light sensor data comprising images in the visible and/or infrared light spectrum,
- a thermal sensor input (12) for obtaining thermal sensor data of a scene including a subject while breathing, said thermal sensor data comprising thermal images in the longwave infrared spectrum, and
- an analysis unit (13) for deriving respiratory effort information by evaluating in the obtained light sensor data motion of a body part of the subject caused by respiration, and for deriving air temperature change information indicating

- air temperature changes during respiration of the subject from the obtained thermal sensor data and for predicting or detecting an asthma attack or asthma based on analysis of the respiratory effort information and the air temperature change information, said analysis evaluating deviations from predetermined or healthy correlations between respiratory efforts and air temperature changes.
2. Device as claimed in claim 1, wherein the analysis unit (13) is configured to derive respiratory effort information indicating respiratory efforts of the subject from the obtained light sensor data and the obtained thermal sensor data.
 3. Device as claimed in claim 1, wherein said analysis unit (13) is configured to evaluate, in the obtained light sensor data, motion of the chest and/or belly portion of the subject caused by respiration to derive the respiratory effort information.
 4. Device as claimed in claim 1, wherein said analysis unit (13) is configured to estimate a stress level of the subject from the obtained light sensor data and/or the obtained thermal sensor data and to take the estimated stress level into account in predicting or detecting an asthma attack or asthma.
 5. Device as claimed in claim 4, wherein said analysis unit (13) is configured to determine one or more vital signs, in particular heart rate and/or heart rate variability, of the subject from the obtained light sensor data and/or the obtained thermal sensor data to estimate a stress level of the subject.
 6. Device as claimed in claim 1, further comprising an audio input (14) for obtaining speech data of the subject representing speech of the subject, wherein said analysis unit (13) is configured to estimate a stress level and/or derive respiratory information of the subject from the obtained speech data and to take the estimated stress level and/or the derived respiratory information into account in predicting or detecting an asthma attack or asthma.
 7. Device as claimed in claim 6, wherein said audio input (14) is configured to obtain speech data representing speech of the subject reading a text, in particular a predetermined text, and wherein said analysis unit (13) is configured to derive reading information indicating reading difficulties and to take the derived reading information into account in predicting or detecting an asthma attack or
- asthma.
8. Device as claimed in claim 1, further comprising an output unit (15) for issuing feedback information indicating feedback about a result of the detection and/or guidance information indicating guidance about actions to be performed to the subject.
 9. Device as claimed in claim 1, further comprising a data input (16) for obtaining environmental data indicating the environment of the subject and/or medication data indicating medication, in particular allergens, administered to the subject, wherein said analysis unit (13) is configured to take the obtained environmental data and/or the obtained medication data into account in predicting or detecting an asthma attack or asthma.
 10. System (1, 2, 3) for detection of an asthma attack or asthma of subject, said system comprising:
 - a light sensor (20) for acquiring light sensor data of the scene, said light sensor data comprising images in the visible and/or infrared light spectrum,
 - a thermal sensor (30) for acquiring thermal sensor data of a scene, said thermal sensor data comprising thermal images in the longwave infrared spectrum, and
 - a device (10, 10a, 10b) as claimed in claim 1 for detection of an asthma attack or asthma of a subject based on the acquired light sensor data and the acquired thermal sensor data.
 11. System as claimed in claim 10, wherein said thermal sensor (30) comprises a longwave camera unit for acquiring said thermal images in the longwave infrared spectrum and/or said light sensor (20) comprises an imaging unit for acquiring said images in the visible and/or infrared light spectrum.
 12. System as claimed in claim 10, further comprising one or more of a microphone (40) for generating speech data representing the speech of the subject, an environmental sensor (50) for generating environmental data indicating the environment of the subject and/or a medication unit (60) for generating medication data indicating medication, in particular allergens, administered to the subject.
 13. Computer program comprising program code means for causing a computer to carry out the steps of a method for enabling detection of an asthma attack or asthma of a subject, when said computer program is carried out on the computer, said method compris-

ing the steps of:

- receiving light sensor data of the scene, said light sensor data comprising images in the visible and/or infrared light spectrum,
- receiving thermal sensor data of a scene including a subject while breathing, said thermal sensor data comprising thermal images in the longwave infrared spectrum,
- deriving respiratory effort information by evaluating in the obtained light sensor data motion of a body part of the subject caused by respiration,
- deriving air temperature change information indicating air temperature changes during respiration of the subject from the obtained thermal sensor data, and
- analyzing the respiratory effort information and the air temperature change information by evaluating deviations from predetermined or healthy correlations between respiratory efforts and air temperature changes allowing to predict or detect an asthma attack or asthma based on said analysis.

Patentansprüche

1. Vorrichtung (10, 10a, 10b) zur Erkennung eines Asthmaanfalls oder von Asthma einer Person, wobei die Vorrichtung umfasst:
 - einen Lichtsensoreingang (11) zum Erhalten von Lichtsensordaten der Szene, wobei die Lichtsensordaten Bilder im sichtbaren und/oder infraroten Lichtspektrum umfassen,
 - einen Wärmesensoreingang (12) zum Erhalten von Wärmesensordaten einer Szene einschließlich einer Person während des Atmens, wobei die Wärmesensordaten Wärmebilder im langwelligen Infrarotspektrum umfassen, und
 - eine Analyseeinheit (13) zum Ableiten von Atmungsanstrengungsinformationen durch Bewertung der durch die Atmung verursachten Bewegung eines Körperteils der Person in den erhaltenen Lichtsensordaten und zum Ableiten von Lufttemperaturänderungsinformationen, die Lufttemperaturänderungen während der Atmung der Person anzeigen, aus den erhaltenen Wärmesensordaten und zum Vorhersagen oder Erkennen eines Asthmaanfalls oder von Asthma basierend auf der Analyse der Atmungsanstrengungsinformationen und der Lufttemperaturänderungsinformationen, wobei die Analyse Abweichungen von vorbestimmten oder gesunden Korrelationen zwischen Atemanstrengungen und Lufttemperaturänderungen bewertet.
2. Vorrichtung nach Anspruch 1, wobei die Analyseeinheit (13) konfiguriert ist, um Atmungsanstrengungsinformationen abzuleiten, die die Atemanstrengungen der Person aus den erhaltenen Lichtsensordaten und den erhaltenen Wärmesensordaten anzeigen.
3. Vorrichtung nach Anspruch 1, wobei die Analyseeinheit (13) konfiguriert ist, um in den erhaltenen Lichtsensordaten die Bewegung des Brust- und/oder Bauchabschnitts der Person zu bewerten, die durch Atmung verursacht wird, um die Atmungsanstrengungsinformationen abzuleiten.
4. Vorrichtung nach Anspruch 1, wobei die Analyseeinheit (13) konfiguriert ist, um ein Stressniveau der Person aus den erhaltenen Lichtsensordaten und/oder den erhaltenen Wärmesensordaten zu schätzen und das geschätzte Stressniveau bei der Vorhersage oder Erkennung eines Asthmaanfalls oder von Asthma zu berücksichtigen.
5. Vorrichtung nach Anspruch 4, wobei die Analyseeinheit (13) konfiguriert ist, um ein oder mehrere Vitalzeichen, insbesondere Herzfrequenz und/oder Herzfrequenzvariabilität, der Person aus den erhaltenen Lichtsensordaten und/oder den erhaltenen Wärmesensordaten zu bestimmen, um ein Stressniveau der Person zu schätzen.
6. Vorrichtung nach Anspruch 1, zudem umfassend einen Audioeingang (14) zum Erhalten von Sprachdaten der Person, die die Sprache der Person darstellen, wobei die Analyseeinheit (13) konfiguriert ist, um ein Stressniveau zu schätzen und/oder Ateminformationen der Person aus den erhaltenen Sprachdaten abzuleiten und das geschätzte Stressniveau und/oder die abgeleiteten Ateminformationen bei der Vorhersage oder Erkennung eines Asthmaanfalls oder von Asthma zu berücksichtigen.
7. Vorrichtung nach Anspruch 6, wobei der Audioeingang (14) konfiguriert ist, um Sprachdaten zu erhalten, die die Sprache der Person darstellen, das einen Text, insbesondere einen vorbestimmten Text, liest und wobei die Analyseeinheit (13) konfiguriert ist, um Leseinformationen abzuleiten, die Leseschwierigkeiten anzeigen und um die abgeleiteten Leseinformationen bei der Vorhersage oder Erkennung eines Asthmaanfalls oder von Asthma zu berücksichtigen.
8. Vorrichtung nach Anspruch 1, zudem umfassend eine Ausgangseinheit (15) zum Ausgeben von Rückmeldungsinformationen, die eine Rückmeldung über ein Ergebnis der Erkennung und/oder Anleitungsinformationen anzeigen, die ei-

ne Anleitung zu Aktionen anzeigen, die an der Person ausgeführt werden sollen.

9. Vorrichtung nach Anspruch 1, zudem umfassend einen Dateneingang (16) zum Erhalten von Umgebungsdaten, die die Umgebung der Person und/oder Medikationsdaten anzeigen, die Medikamente, insbesondere Allergene, anzeigen, die der Person verabreicht werden, wobei die Analyseeinheit (13) konfiguriert ist, um die erhaltenen Umgebungsdaten und/oder die erhaltenen Medikationsdaten bei der Vorhersage oder Erkennung eines Asthmaanfalls oder von Asthma zu berücksichtigen. 5 10
10. System (1, 2, 3) zur Erkennung eines Asthmaanfalls oder von Asthma einer Person, wobei das System umfasst: 15
- einen Lichtsensor (20) zum Erfassen von Lichtsensordaten der Szene, wobei die Lichtsensordaten Bilder im sichtbaren und/oder infraroten Lichtspektrum umfassen, 20
 - einen Wärmesensor (30) zum Erfassen von Wärmesensordaten einer Szene, wobei die Wärmesensordaten Wärmebilder im langwelligen Infrarotspektrum umfassen, und 25
 - eine Vorrichtung (10, 10a, 10b) nach Anspruch 1 zur Erkennung eines Asthmaanfalls oder von Asthma einer Person basierend auf den erfassten Lichtsensordaten und der erfassten Wärmesensordaten. 30
11. System nach Anspruch 10, wobei der Wärmesensor (30) eine langwellige Kameraeinheit zum Erfassen der Wärmebilder im langwelligen Infrarotspektrum umfasst und/oder der Lichtsensor (20) eine Abbildungseinheit zum Erfassen der Bilder im sichtbaren und/oder infraroten Lichtspektrum umfasst. 35 40
12. System nach Anspruch 10, zudem umfassend ein oder mehrere Elemente unter Mikrofonen (40) zum Erzeugen von Sprachdaten, die die Sprache der Person darstellen, einem Umgebungssensor (50) zum Erzeugen von Umgebungsdaten, die die Umgebung der Person anzeigen, und/oder einer Medikationseinheit (60) zum Erzeugen von Medikationsdaten, die Medikamente, insbesondere Allergene, anzeigen, die der Person verabreicht werden. 45 50
13. Computerprogramm umfassend Programmcode-mittel, um zu bewirken, dass ein Computer die Schritte eines Verfahrens ausführt, um das Erkennen eines Asthmaanfalls oder von Asthma einer Person zu ermöglichen, wenn das Computerprogramm auf dem Computer ausgeführt wird, wobei das Ver-

fahren die Schritte umfasst zum:

- Empfangen von Lichtsensordaten der Szene, wobei die Lichtsensordaten Bilder im sichtbaren und/oder infraroten Lichtspektrum umfassen, 5
- Empfangen von Wärmesensordaten einer Szene einschließlich einer Person während des Atmens, wobei die Wärmesensordaten Wärmebilder im langwelligen Infrarotspektrum umfassen, 10
- Ableiten von Atmungsanstrengungsinformationen durch Bewertung der durch die Atmung verursachten Bewegung eines Körperteils der Person in den erhaltenen Lichtsensordaten, 15
- Ableiten von Lufttemperaturänderungsinformationen, die Lufttemperaturänderungen während der Atmung der Person anzeigen, aus den erhaltenen Wärmesensordaten und 20
- Analysieren der Atmungsanstrengungsinformationen und Lufttemperaturänderungsinformationen durch Bewertung von Abweichungen von vorbestimmten oder gesunden Korrelationen zwischen Atmungsanstrengungen und Lufttemperaturänderungen, um basierend auf dieser Analyse einen Asthmaanfall oder Asthma vorherzusagen oder zu erkennen. 25

Revendications

1. Dispositif (10, 10a, 10b) de détection d'une attaque d'asthme ou de l'asthme chez un sujet, ledit dispositif comprenant : 30
- une entrée de capteur lumineux (11) pour obtenir des données du capteur lumineux de la scène, lesdites données du capteur lumineux comprenant des images dans le spectre lumineux visible et/ou infrarouge, 35
- une entrée de capteur thermique (12) pour obtenir des données du capteur thermique d'une scène incluant un sujet en train de respirer, lesdites données du capteur thermique comprenant des images thermiques dans le spectre infrarouge à ondes longues, et 40
 - une unité d'analyse (13) pour déduire des informations sur l'effort respiratoire en évaluant dans les données obtenues par le capteur lumineux le mouvement d'une partie du corps du sujet provoqué par la respiration, et pour déduire des informations sur les variations de température de l'air indiquant les variations de température de l'air pendant la respiration du sujet à partir des données obtenues par le capteur thermique et pour prédire ou détecter une attaque d'asthme ou de l'asthme sur la base de l'analyse des informations sur l'effort respiratoire et des informations sur les variations de température 45 50 55

- de l'air, ladite analyse évaluant des écarts à partir de corrélations prédéterminées ou asymptomatiques entre les efforts respiratoires et les variations de température de l'air.
2. Dispositif selon la revendication 1, dans lequel l'unité d'analyse (13) est configurée pour déduire des informations sur l'effort respiratoire indiquant les efforts respiratoires du sujet à partir des données obtenues par le capteur lumineux et des données obtenues par le capteur thermique.
 3. Dispositif selon la revendication 1, dans lequel ladite unité d'analyse (13) est configurée pour évaluer, dans les données obtenues par le capteur lumineux, le mouvement de la partie de la poitrine et/ou de la ventre du sujet provoqué par la respiration pour en déduire des informations sur l'effort respiratoire.
 4. Dispositif selon la revendication 1, dans lequel ladite unité d'analyse (13) est configurée pour évaluer un niveau de stress du sujet à partir des données obtenues par le capteur lumineux et/ou des données obtenues par le capteur thermique et pour prendre en compte le niveau de stress évalué dans la prévision ou la détection d'une attaque d'asthme ou de l'asthme.
 5. Dispositif selon la revendication 4, dans lequel ladite unité d'analyse (13) est configurée pour déterminer un ou plusieurs signes vitaux, en particulier la fréquence cardiaque et/ou la variabilité de la fréquence cardiaque du sujet à partir des données obtenues par le capteur lumineux et/ou des données obtenues par le capteur thermique pour évaluer un niveau de stress du sujet.
 6. Dispositif selon la revendication 1, comprenant de plus une entrée audio (14) servant à obtenir des données vocales du sujet représentant l'élocution du sujet, dans lequel ladite unité d'analyse (13) est configurée pour évaluer un niveau de stress et/ou déduire des informations respiratoires du sujet à partir des données vocales obtenues et pour prendre en compte le niveau de stress évalué et/ou les informations respiratoires déduites dans la prévision ou la détection d'une attaque d'asthme ou de l'asthme.
 7. Dispositif selon la revendication 6, dans lequel ladite entrée audio (14) est configurée pour obtenir des données vocales représentant l'élocution du sujet en train de lire un texte, en particulier un texte prédéterminé, et dans lequel ladite unité d'analyse (13) est configurée pour déduire des informations de lecture indiquant des difficultés de lecture et pour prendre en compte les informations de lecture déduites dans la prévision ou la détection d'une attaque d'asthme ou de l'asthme.
 8. Dispositif selon la revendication 1, comprenant de plus une unité de sortie (15) pour émettre des informations indiquant un retour d'informations sur un résultat de la détection et/ou des informations d'orientation indiquant des conseils sur les actions à effectuer chez le sujet.
 9. Dispositif selon la revendication 1, comprenant de plus une entrée de données (16) servant à obtenir des données environnementales indiquant l'environnement du sujet et/ou des données sur la médication indiquant les médicaments, en particulier les allergènes, administrés au sujet, dans lequel ladite unité d'analyse (13) est configurée pour prendre en compte les données environnementales obtenues et/ou les données de médication obtenues pour prédire ou détecter une attaque d'asthme ou l'asthme.
 10. Système (1, 2, 3) de détection d'une attaque d'asthme ou de l'asthme chez un sujet, ledit système comprenant :
 - un capteur lumineux (20) servant à acquérir des données du capteur lumineux de la scène, lesdites données du capteur lumineux comprenant des images dans le spectre lumineux visible et/ou infrarouge,
 - un capteur thermique (30) servant à acquérir des données du capteur thermique d'une scène, lesdites données de capteur thermique comprenant des images thermiques dans le spectre infrarouge à ondes longues, et
 - un dispositif (10, 10a, 10b), selon la revendication 1, destiné à la détection d'une attaque d'asthme ou de l'asthme chez un sujet sur la base des données acquises par le capteur lumineux et des données acquises par le capteur thermique.
 11. Système selon la revendication 10, dans lequel ledit capteur thermique (30) comprend une caméra à ondes longues servant à acquérir lesdites images thermiques dans le spectre infrarouge à ondes longues et/ou ledit capteur lumineux (20) comprend une unité d'imagerie servant à acquérir lesdites images dans le spectre lumineux visible et/ou infrarouge.
 12. Système selon la revendication 10, comprenant de plus un ou plusieurs éléments parmi un microphone (40) pour générer des données vocales représentant l'élocution du sujet, un capteur environnemental (50) servant à générer des données environnementales indiquant l'environnement

du sujet et/ou une unité de médication (60) pour générer des données de médication indiquant les médicaments, en particulier les allergènes, administrés au sujet.

5

13. Programme informatique comprenant des moyens de code de programme pour qu'un ordinateur exécute les étapes d'un procédé permettant d'activer la détection d'une attaque d'asthme ou de l'asthme chez un sujet, lorsque ledit programme informatique est exécuté sur l'ordinateur, ledit procédé comprenant les étapes de :

10

- recevoir des données du capteur lumineux de la scène, lesdites données du capteur lumineux comprenant des images dans le spectre lumineux visible et/ou infrarouge,

15

- recevoir les données du capteur thermique d'une scène incluant un sujet en train de respirer, lesdites données du capteur thermique comprenant des images thermiques dans le spectre infrarouge à ondes longues,

20

- déduire des informations sur l'effort respiratoire en évaluant, dans les données obtenues par le capteur lumineux, le mouvement d'une partie du corps du sujet provoqué par la respiration,

25

- déduire des données obtenues par le capteur thermique des informations sur les variations de température de l'air indiquant les variations de température de l'air pendant la respiration du sujet, et

30

- analyser des informations sur l'effort respiratoire et aux variations de la température de l'air en évaluant les écarts par rapport à des corrélations prédéterminées ou asymptotiques entre les efforts respiratoires et les variations de la température de l'air, permettant de prévoir ou de détecter une attaque d'asthme ou l'asthme sur la base de ladite analyse.

35

40

45

50

55

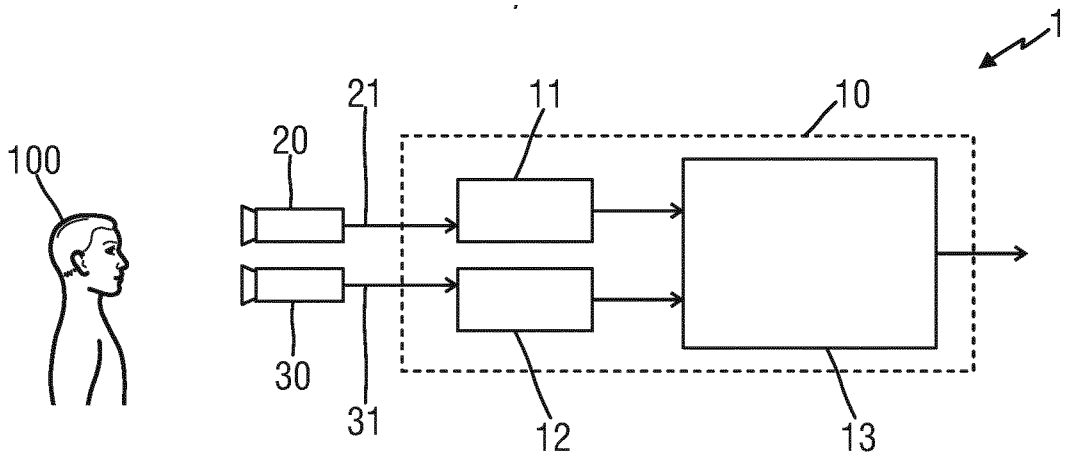

FIG. 1

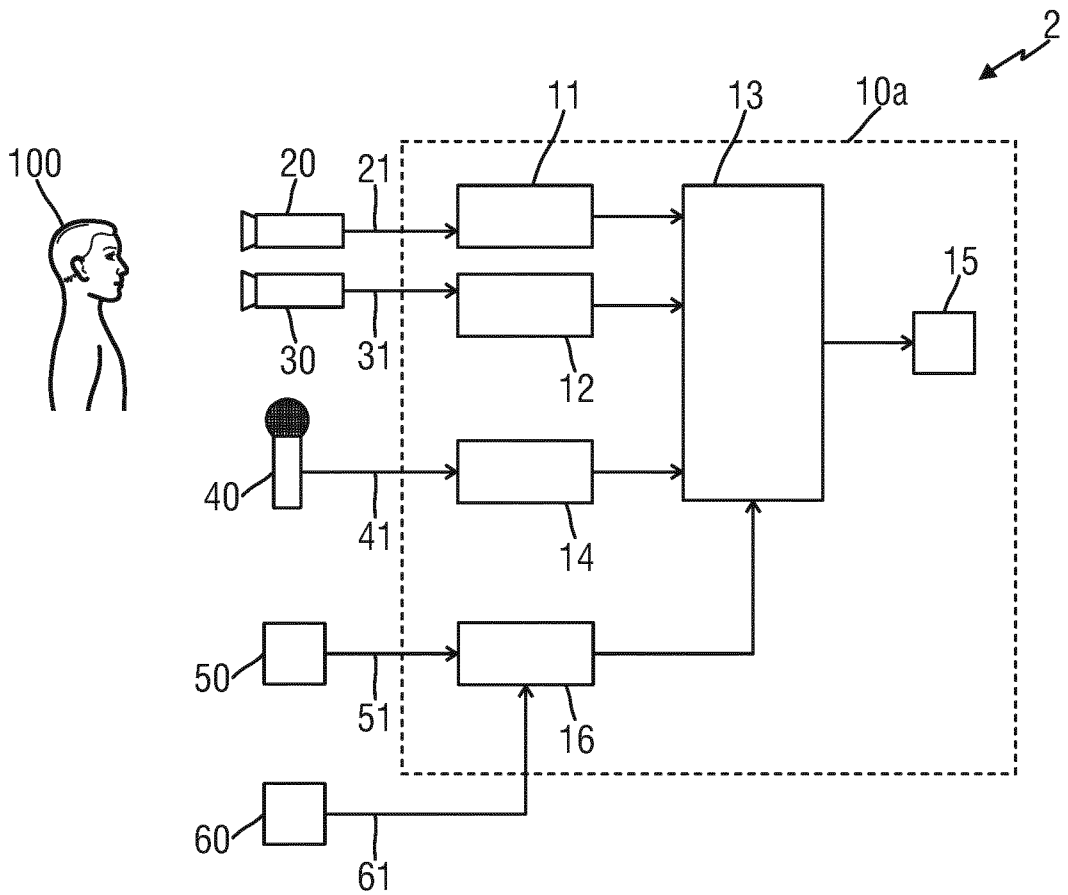

FIG. 2

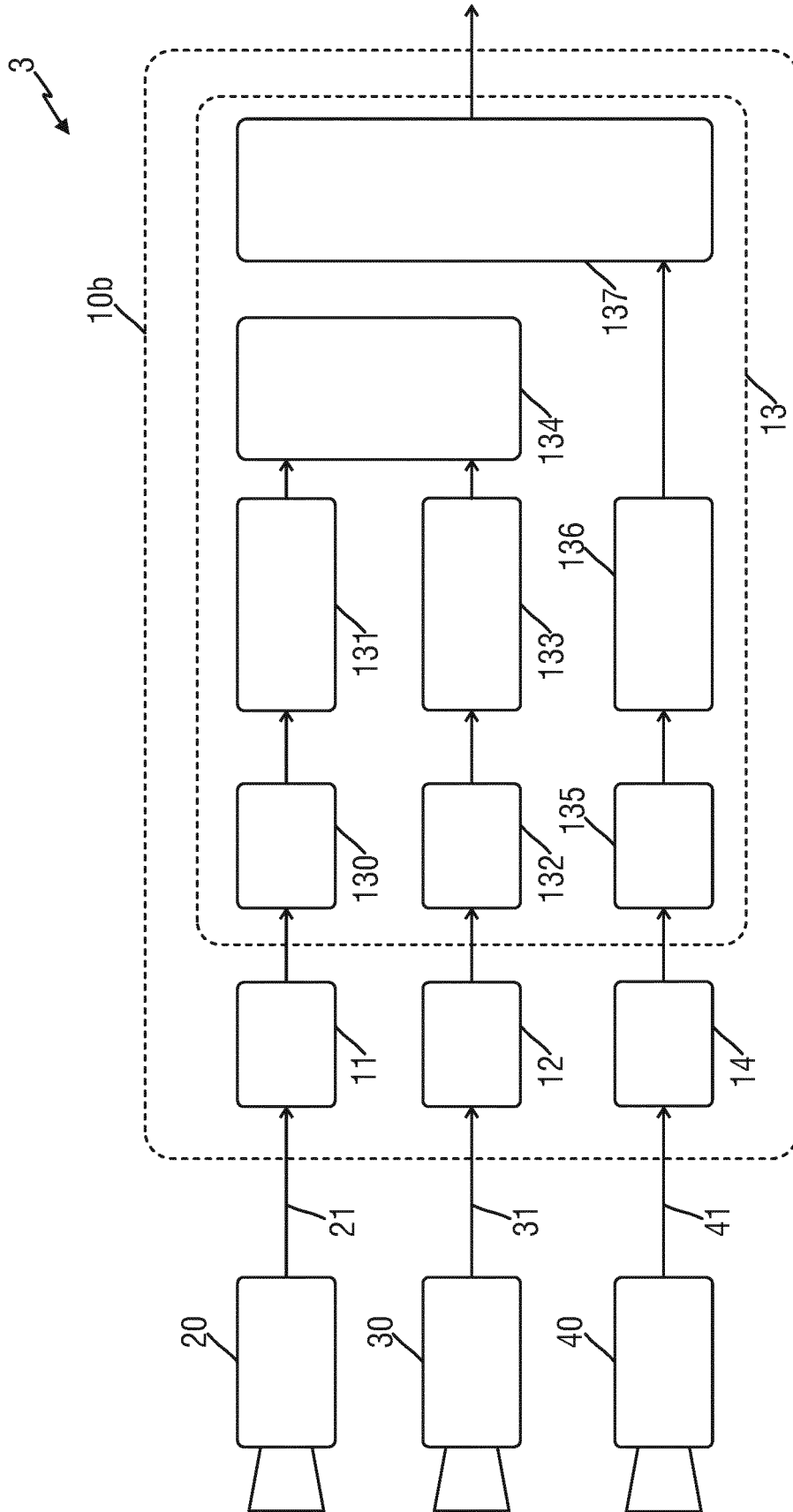

FIG.3

REFERENCES CITED IN THE DESCRIPTION

This list of references cited by the applicant is for the reader's convenience only. It does not form part of the European patent document. Even though great care has been taken in compiling the references, errors or omissions cannot be excluded and the EPO disclaims all liability in this regard.

Patent documents cited in the description

- US 9131902 B2 [0010] [0022]
- US 2016206216 A1 [0013]

Non-patent literature cited in the description

- **PEREIRA CARINA BARBOSA et al.** Remote monitoring of breathing dynamics using infrared thermography. *BIOMEDICAL OPTICS EXPRESS* 1 NOV 2015, 01 November 2015, vol. 6, ISSN 2156-7085, 4378-4394 [0011]
- Analysis of breathing air flow patterns in thermal imaging. **FEI J et al.** CONFERENCE PROCEEDINGS. ANNUAL INTERNATIONAL CONFERENCE OF THE IEEE ENGINEERING IN MEDICINE AND BIOLOGY SOCIETY (IEEE CAT. NO. 06CH37748). IEEE, 2006, 7 [0012]

专利名称(译)	用于检测受试者的哮喘发作或哮喘的装置，系统和方法		
公开(公告)号	EP3503803A1	公开(公告)日	2019-07-03
申请号	EP2017751778	申请日	2017-08-17
[标]申请(专利权)人(译)	皇家飞利浦电子股份有限公司		
申请(专利权)人(译)	皇家飞利浦N.V.		
当前申请(专利权)人(译)	皇家飞利浦N.V.		
[标]发明人	MENA BENITO MARIA ESTRELLA KIRENKO IHOR OLEHOVYCH AARTS RONALDUS MARIA		
发明人	MENA BENITO, MARIA, ESTRELLA KIRENKO, IHOR, OLEHOVYCH AARTS, RONALDUS, MARIA		
IPC分类号	A61B5/113 A61B5/00 A61B5/087 A61B5/01		
CPC分类号	A61B5/0077 A61B5/015 A61B5/087 A61B5/1135 A61B5/4803 A61B5/486 A61B5/7275 G16H30/40 G16H50/20 A61B5/0075 A61B5/01 A61B5/02055 A61B5/02405 A61B5/0873 A61B5/165 A61B5/4848 A61B5/7278 A61B2560/0252 A61B2562/0204 A61B2562/0271 G16H30/20 G16H50/30		
优先权	2016185302 2016-08-23 EP		
其他公开文献	EP3503803B1		
外部链接	Espacenet		

摘要(译)

本发明涉及用于检测对象的哮喘发作或哮喘的装置 (10、10a, 10b) , 系统 (1、2、3) 和方法。为此目的, 该设备包括光传感器输入 (11) , 例如, 光传感器输入 (11) 。2D相机, 用于获取场景的光传感器数据和热传感器输入 (12) , 例如 热像仪, 用于获取呼吸时包括被摄体在内的场景的热传感器数据。分析单元 (13) 获得这些数据, 并且从所获得的光传感器数据和/或所获得的热传感器数据中获得指示对象的呼吸努力的呼吸努力信息, 并且从所获得的热传感器中获得指示对象在呼吸期间的气流的气流信息。数据。此外, 分析单元 (13) 基于对呼吸力信息和气流信息的分析来预测或检测哮喘发作或哮喘, 所述分析评估与呼吸力和气流之间的预定或健康相关性的偏差。