



(19)

Europäisches Patentamt
European Patent Office
Office européen des brevets



(11)

EP 1 317 902 B1

(12)

EUROPEAN PATENT SPECIFICATION

(45) Date of publication and mention
of the grant of the patent:
09.11.2005 Bulletin 2005/45

(51) Int Cl.⁷: **A61B 5/0285**, G06F 17/00,
A61B 5/021

(21) Application number: **02027552.5**

(22) Date of filing: **09.12.2002**

(54) **Biological data observation apparatus**

Vorrichtung zur Beobachtung biologischer Daten

Système d'observation de données biologiques

(84) Designated Contracting States:
DE FR GB

(30) Priority: **10.12.2001 JP 2001375925**
11.12.2001 JP 2001377083
07.01.2002 JP 2002000856
16.04.2002 JP 2002113656
30.10.2002 JP 2002316337

(43) Date of publication of application:
11.06.2003 Bulletin 2003/24

(73) Proprietor: **Kabushiki Gaisha K-and-S**
Kariya-shi Aichi 448-0001 (JP)

(72) Inventors:
• **Kondo Shinji**
Igaya-cho Kariya-shi Aichi 448-0001 (JP)

• **Sakakibara Noriaki**
Igaya-cho Kariya-shi Aichi 448-0001 (JP)
• **Takemoto Toru**
Toyota-shi Aichi 471-8515 (JP)
• **Honda Toshihiro**
Toyota-shi Aichi 471-8515 (JP)

(74) Representative: **Müller-Boré & Partner**
Patentanwälte
Grafinger Strasse 2
81671 München (DE)

(56) References cited:
EP-A- 0 804 899 **EP-A- 1 046 373**
WO-A-00/55579 **US-A- 5 309 916**

EP 1 317 902 B1

Note: Within nine months from the publication of the mention of the grant of the European patent, any person may give notice to the European Patent Office of opposition to the European patent granted. Notice of opposition shall be filed in a written reasoned statement. It shall not be deemed to have been filed until the opposition fee has been paid. (Art. 99(1) European Patent Convention).

Description

[0001] This invention relates to a biological data measuring apparatus which measures biological data such as blood pressure, pulses, etc.

[0002] In one conventional method of continuously measuring blood pressure values, a cuff is used to measure a blood pressure value of a subject at an initial stage of measurement and thereafter, a blood pressure value is calculated on the basis of transition of a photoelectric volume pulse wave obtained from a photoelectric sensor. Thus, both the cuff and the photoelectric sensor are commonly used at the initial stage of the measurement. Calibration is carried out to correlate each one of a photoelectric pulse wave (relative value) and a pressure pulse wave (absolute value) with the other. Once the calibration is carried out, a blood pressure value of the subject can subsequently be calculated only from the measurement by the photoelectric sensor without measurement by the cuff.

[0003] However, several times of pressure application against an artery of the subject inflict pain on him or her when the measurement with the cuff is done over again.

[0004] US-A-5 309 916 discloses a device for measuring blood pressure, including a sensor arrangement which is releasably attached to the exterior of a body and which is electrically conductively connected with electronic circuit. The sensor arrangement and the circuit are configured to determine, in at least one measuring region of the body, a valve which is a measure for a variable that changes periodically over time in the rhythm of the pulse beat and which is correlated with the blood pressure. This variable may, for example, be the flow velocity and/or flow quantity and/or the volume of the arterial blood and/or a cross-sectional dimension and/or the flow cross section area of an arterial blood vessel. The sensor and circuit further determine a value which is a measure for the pulse wave velocity. By linking the two values together and including at least one calibration value, at least one value that is characteristic for of the blood pressure can be determined. The device makes it possible to measure the blood pressure of a person at least quasi-continuously with relatively little bother for the person.

[0005] Therefore, an object of the present invention is to provide a biological data observation apparatus which can calculate a blood pressure value without the preparatory measurement with the cuff. This object is solved by a biological data observation apparatus having the features according to claim 1. Preferred embodiments of the invention are defined in the dependent claims. A biological data observation apparatus is provided comprising a measuring unit including at least a photoelectric sensor including a light emitting element for emitting light with a predetermined wavelength onto a blood vessel of a subject and a light detecting element for detecting, as a photoelectric volume pulse wave, a change in an amount of transmitted or reflected light resulting from the light emitted from the light emitting element, an operational unit into which a result of measurement by the measuring unit is supplied so that the operational unit carries out an operational process based on the supplied result of measurement, a storage area storing data of the result of measurement or the like, and a display unit displaying a result of calculation performed by the operational unit, characterized in that the storage area stores blood pressure conversion data correlating a pulse wave area and a blood pressure value in order that a pulse wave area may be converted to a blood pressure value as an absolute value, the pulse wave area being obtained by integrating a waveform of the photoelectric volume pulse wave per heartbeat, and the operational unit calculates the pulse wave area on the basis of the photoelectric volume pulse wave obtained from the subject and further calculates a blood pressure value of the subject on the basis of the calculated pulse wave area and the blood pressure conversion data.

[0006] According to the above-described biological data observation apparatus, the storage area stores the blood pressure conversion data in which the pulse-wave area of the photoelectric volume pulse-wave and blood pressure value are correlated with each other. Accordingly, when a photoelectric volume pulse wave of the subject is measured by the photoelectric sensor, a blood pressure value of the subject is obtained from the pulse wave area of the photoelectric volume pulse wave and the blood pressure conversion data. Consequently, the above-described apparatus can eliminate the measurement of pressure pulse wave by a cuff in the initial stage of measurement and resultant calibration, whereupon the measuring procedure can be simplified.

[0007] The invention will be described, merely by way of example, with reference to the accompanying drawings, in which:

FIG. 1 is a block diagram of a biological data observation apparatus in accordance with a first embodiment of the present invention;

FIG. 2 is a sectional view of a pulse-wave measuring device;

FIG. 3 is a block diagram of a measurement artificial human body model;

FIG. 4A is a waveform chart of photoelectric volume pulse-wave;

FIG. 4B is a graph showing a correlation between a pulse-wave area and a flow velocity value;

FIG. 4C is a graph showing a correlation between the pulse-wave area and a blood pressure value;

FIG. 5 is a flowchart showing a procedure for calculating a blood pressure value of a subject;

FIG. 6 is a flowchart showing another procedure for calculating a blood pressure value of a subject;

FIG. 7 is a block diagram of a measuring artificial human body model including an animal constituting an artificial human body part;

FIG. 8 illustrates a concept of another photoelectric sensor employed in the biological data observation apparatus in accordance with a second embodiment of the invention;

FIGS. 9A to 9C are graphs showing transition of the photoelectric volume pulse waves;

FIG. 10 is a block diagram of the biological data observation apparatus in accordance with a third embodiment of the invention;

FIG. 11 is a flowchart showing a procedure for calculating a blood pressure value;

FIGS. 12A and 12B are graphs showing transition of photoelectric volume pulse wave before and after substitution respectively;

FIG. 13 is a flowchart showing a procedure for calculating an oxygen saturation of arterial blood;

FIG. 14 is a block diagram of the biological data observation apparatus in accordance with a fourth embodiment of the present invention;

FIG. 15 is a partially broken perspective view of a capsule of a sweat amount measuring device;

FIG. 16A is a graph showing transition of peak value data of a photoelectric volume pulse wave;

FIG. 16B is a graph showing transition of sweat amount data;

FIG. 16C is a graph showing transition of composite data A2;

FIG. 17 is a graph showing transition of anesthesia depth;

FIGS. 18A and 18B are graphs showing transition of primary biological data;

FIGS. 19A and 19B are graphs showing transition of other biological data;

FIG. 20 is a graph showing the anesthesia depth;

FIG. 21 is a block diagram of the biological data observation apparatus to which an electrocardiograph and an electroencephalograph are added; and

FIGS. 22A and 22B are graphs showing correlations between skin temperature and sweat amount, and blood flow amount respectively.

[0008] A first embodiment of the present invention will be described with reference to FIGS. 1 to 7. Referring to FIG. 1, a biological data observation apparatus in accordance with the first embodiment of the invention is shown. The biological data observation apparatus comprises a pulse-wave measuring device 20, a data processing device 10 connected to an output line of the pulse-wave measuring device 20 to carry out operational processing, and a monitor 30 (serving as a display unit in the invention) displaying results of operational processing by the data processing device 10. The pulse-wave measuring device 20 includes a photoelectric sensor (serving as a measuring unit in the invention) irradiating light with a predetermined wavelength onto a blood vessel of a subject 5 thereby to detect, as a photoelectric volume pulse wave, a change in amount of resultant transmitted or reflected light.

[0009] The data processing device 10 includes an A/D converter 11, a CPU 12 (serving as an operational unit in the invention) and a storage area 13. The photoelectric volume pulse wave detected by the pulse wave measuring device 20 is continuously supplied via an A/D converter 11 into the CPU 12. The CPU 12 carries out operational processing on the basis of the digitized photoelectric volume pulse wave data, blood pressure conversion data written in the storage area 13, flow velocity conversion data, etc., thereby calculating a blood pressure value of the subject per heartbeat. The monitor 30 displays a blood pressure waveform and photoelectric volume pulse wave each in the unit of heartbeat.

[0010] Referring to FIG. 2, the pulse-wave measuring device 20 comprises a wrist band 21 and a body 22. The wrist band 21 has both ends adapted to be joined with each other so that the pulse-wave measuring device 20 is fixed around a wrist of the subject 5. The body 22 includes a casing 23 having an open side applied onto an arm of the subject 5 and a plate 24 closing the open side. The plate 24 is elastically supported by a coil spring 25 disposed between the casing 23 and the plate, so that the plate is usually pressed against a skin of the subject 5.

[0011] The plate 24 has a plurality of through holes into which a plurality of light emitting elements 26A and light detecting elements 26B are inserted from inside the casing 23 to be fixed. The light emitting elements 26A and light detecting elements 26B constitute a photoelectric sensor 26 for detecting a relative change in blood flow of the subject 5 as a change in an amount of light. Each light emitting element comprises a light-emitting diode (LED), whereas each light detecting element comprises a phototransistor. Each LED obtains output according to an amount of blood flow from the phototransistor. For example, light used for this purpose belongs to a wavelength range allowing light to be absorbed into and reflected on both oxyhemoglobin and deoxyhemoglobin in blood or light having a wavelength of about 640 nm is used. In this case, since output of the phototransistor changes with a change in the content of hemoglobin in blood, output obtained corresponds to a relative change in an amount of blood flow. The pulse-wave measuring device 20 includes a drive circuit (not shown) for driving the light emitting elements 26A and a receiving circuit (not shown) for processing an output signal delivered from the light detecting element 26B. Data of an obtained photoelectric volume pulse wave is transmitted via an output line to the data processing device 10.

[0012] A blood pressure value P_t of the subject is calculated mainly by operational processing in the embodiment

as will be described later. The operational processing requires reference data of a blood pressure value P_o and a flow velocity value V_o . For this purpose, the storage area 13 stores blood pressure conversion data for calculation of the blood pressure value P_o and flow velocity conversion data for calculation of the flow velocity value V_o . Both data are obtained from experiments using a measuring artificial human body model 40 as will be described in detail later.

5 **[0013]** The measuring artificial human body model 40 reproduces a rested state of a sampling object with a standard form. The model 40 comprises a tank 41 storing an equivalent 49 to human blood (hereinafter, "blood equivalent"), a tube 42 through which the blood equivalent 49 is re-circulated and transferred, and a pump 43 pressure-feeding the blood equivalent 49 for every standard heartbeat time which is one of the sample person at rest, for example, 0.75 sec. The blood equivalent preferably has a similar composition as the human blood, and blood of any animal may be used, for example. The tube 42 serves as a pipe in the invention and corresponds to a blood vessel. The pressure of the pump 43 is adjustable. A flow rate sensor 44 is provided in the middle of the tube 42 for measuring a flow rate of the blood equivalent 49 per standard heartbeat time. The flow rate sensor 44 serves as a flow rate measuring section in the invention. A photoelectric sensor 45 is provided for detecting, as a change in an amount of light, a change in the flow rate of the blood equivalent 49 in the tube. A pressure measuring section 46 includes a container 47 partitioned by a rubber pressure valve 47A into upper and lower chambers and a pressure sensor 48 connected to the lower chamber side of the container 47. The tube 42 is connected to the upper chamber so that the blood equivalent can be re-circulated therein.

10 **[0014]** The tube 42 has an inner diameter approximately equal to one of a blood vessel in a wrist of the sample person in the rested state. The inner diameter of the tube 42 is set at $\phi 2.5$ mm in the embodiment. The foregoing "rested state" is set because the artificial model 40 reproduces the rested state of the sample person. The blood vessel in the wrist is selected because a part of the subject where measurement actually is carried out is a wrist. It is desirable that the photoelectric sensor 26 of the pulse-wave measuring device 20 and the photoelectric sensor 45 of the artificial model 40 should be of the same type.

15 **[0015]** The pressure valve 47A is displaced downward upon pressure feed of the blood equivalent 49, whereby the pressure at the lower chamber side is varied to be rendered maximum. The pressure corresponding to a systolic blood pressure of the human body at rest is measured by the pressure sensor 48. On the other hand, the pressure valve 47A is moved to the upper chamber side after pressure feed of the blood equivalent 49, whereby the pressure at the lower chamber side is varied to be rendered minimum. The pressure corresponding to a diastolic blood pressure of the human body at rest is measured by the pressure sensor 48. Further, output lines of the photoelectric sensor 45, flow-rate sensor 44, pressure sensor 48 are connected to the A/D converter 11. In the artificial model 40 constructed as described above, the pressure at which the blood equivalent 49 is pressure-fed by the pump 43 is changed to various values so that the photoelectric volume pulse wave and the pressure value of the blood equivalent 49 are measured by the photoelectric sensor 45 and the pressure sensor 48 every time of setting respectively, whereupon the subsequent blood pressure conversion data and flow rate conversion data are calculated. See FIGS. 4A to 4C.

20 **[0016]** In the blood pressure conversion data, a pulse wave area obtained by integrating the photoelectric volume pulse wave regarding the tube 42 per heartbeat and the blood pressure value of the blood equivalent obtained from the pressure sensor 48 are correlated with each other. The blood pressure conversion data is calculated at every systolic blood pressure and every diastolic blood pressure. See FIG. 4C. On the other hand, the pulse wave area and flow velocity value are correlated with each other in the flow velocity conversion data. See FIG. 4B. The flow velocity value is obtained by dividing a flow rate measured by the flow rate sensor 44 by a sectional area of the tube 42.

25 **[0017]** A manner of calculating a blood pressure value P_t in any period will be described with reference to FIG. 5. Firstly, a wrist band 21 is fastened around an arm of the subject 5, and the pulse-wave measuring device 20 is set so that the photoelectric sensor 26 is located above a blood vessel of the subject 5. When the photoelectric sensor 26 has been set, a photoelectric volume pulse wave is measured by the sensor 26 while the subject 5 is in a temporally rested state or measurement reference state (measurement reference time). The measured photoelectric volume pulse wave is delivered via the A/D converter 11 to CPU 12 (step a).

30 **[0018]** The subject 5 is rested under the above-noted condition. Accordingly, a mean value of the inner diameter of the subject's blood vessel takes approximately the same value as the inner diameter of the tube 42 although the inner diameter value of the subject's blood vessel varies to some extent. Consequently, reference blood pressure and flow velocity values P_o and V_o can be calculated on the basis of the blood pressure data and flow velocity conversion data respectively. However, both data cannot be used when the subject changes from a rested state to a non-rested state such that the inner diameter of the blood vessel differs from the inner diameter of the tube 42 as the result of expansion and contraction of the blood vessel.

35 **[0019]** The procedure for calculation of the blood pressure value P_o and flow velocity value V_o will be described more concretely. A pulse wave area per heartbeat is calculated on the basis of the photoelectric volume pulse wave (relative value) of the subject 5. The pulse wave area per heartbeat is converted to a value per above-mentioned standard heartbeat time (step b). For example, a pulse wave area s_2 is converted to a value per standard heartbeat time t_2 as follows:

EP 1 317 902 B1

$$s_2 = s_1 \times t_2 / t_1$$

where t_1 is a heartbeat time of the subject, t_2 is a standard heartbeat time and s_1 is a pulse wave area of the subject 5 per heartbeat. Reference symbol "S" will hereinafter designate the converted pulse wave area s_2 .

[0020] A flow velocity value (absolute value) in the measurement reference state is calculated from the converted pulse wave area S and flow velocity conversion data as shown in FIG. 4B (step c). For example, the flow velocity value is represented by V_o when the converted pulse wave area S is represented by S_o . Further, the blood pressure value (absolute value) of the subject 5 in the measurement reference state is calculated from the converted pulse wave area S and the blood pressure conversion data as shown in FIG. 4C (step c). When the converted pulse wave area is represented by S_o , the blood pressure value P_o is represented as systolic blood pressure value P_{ho} and diastolic blood pressure value P_{Lo} .

[0021] When the reference blood pressure value P_o and flow velocity V_o are obtained in the above-described manner, the blood pressure value P_t is thereafter calculated by the following operational processing in a suitable period. The inventors have found that there is a correlation between an inner diameter of a blood vessel and a peak value of a photoelectric volume pulse wave. For example, the following relationship holds:

$$D_o / D_t = k \times \phi_o / \phi_t \quad (1)$$

where D_o is a peak value of the photoelectric volume pulse wave at the measurement reference time, ϕ_o is an inner diameter of blood vessel, D_t is a peak value of the photoelectric volume pulse wave in any period after the measurement reference time, and ϕ_t is an inner diameter of a blood vessel. Accordingly, the inner diameter ϕ_t of the subject's blood vessel can be calculated on the basis of the peak values D_o and D_t of the photoelectric volume pulse wave. Further, since the product of a sectional area of a tube and a flow velocity of a liquid flowing through the tube is constant, the following relationship holds between a flow velocity value V_o of the blood at a measurement reference time and a flow velocity V_t of the blood in any period:

$$\pi(\phi_o/2)^2 \times V_o = \pi(\phi_t/2)^2 \times V_t \quad (2)$$

[0022] Accordingly, the following equation (3) is obtained on the basis of the equations (1) and (2) such that the flow velocity value V_t of the subject 5 in any period can be calculated:

$$V_t = (D_o / k D_t)^2 \times V_o \quad (3)$$

[0023] A blood pressure variation ΔP refers to a variation in the blood pressure value in any period relative to the value at a measurement reference time. The blood pressure variation ΔP is calculated on the basis of the calculated flow velocity value V_t in any period, the flow velocity value V_o at the measurement reference time and the blood pressure value P_o at the measurement reference time (step d). More specifically, a relation expressed by the following equation (4) holds between the flow velocity and blood pressure values V_o and P_o at the measurement reference time and the flow velocity and blood pressure values V_t and P_t in any period. Equation (5) is obtained from the equation (4). Reference symbol ρ designates a density of blood.

$$P_o + \rho V_o^2 / 2 = P_t + \rho V_t^2 / 2 \quad (4)$$

$$\Delta P = P_t - P_o = \rho / 2 (V_o^2 - V_t^2) \quad (5)$$

$$P_t = P_o + \Delta P \quad (6)$$

[0024] Accordingly, the blood pressure variation amount ΔP can be calculated on the basis of equation (5). As a result, the systolic blood pressure value P_{ho} in the measurement reference state is substituted for " P_o " in equation (6) in order that a systolic blood pressure P_{ht} per heartbeat in any period may be calculated. In order that a diastolic blood

pressure PL_t per heartbeat in any period may be calculated, the diastolic blood pressure value PL_o in the measurement reference state is substituted for " P_o " in equation (6)(step e).

[0025] As obvious from the foregoing, the storage area 13 stores the blood pressure conversion data and flow rate conversion data. When the subject is in the measurement reference state (rested state), the reference flow velocity and blood pressure values V_o and P_o are calculated on both conversion data respectively. Further, in any period after calculation of the reference flow velocity and blood pressure values V_o and P_o , the blood pressure variation amount ΔP , which is a variation in the blood pressure value in any period relative to the value at a measurement reference time, can be obtained by operation from the peak values D_o and D_t of the photoelectric volume pulse wave and the flow velocity value V_o at the measurement reference time. The blood pressure value P_t in any period is calculated on the basis of the obtained blood pressure variation amount ΔP . Consequently, once the reference flow velocity and blood pressure values V_o and P_o are calculated, the blood pressure value P_t can be obtained by operation whether the subject 5 is in a rested state or not. Thus, the blood pressure value P_t in any period can be calculated on the basis of only the measurement of the photoelectric volume pulse wave by the photoelectric sensor 26 without measurement of pressure pulse wave by the cuff etc. As a result, the blood pressure measuring procedure can be simplified.

[0026] The "non-rested state" refers to a case where physical conditions of the subject 5 change with course of measurement such that the inner diameter of blood vessel of the subject is contracted or expanded as compared with the rested state.

[0027] The artificial model 40 includes a laser displacement meter 95 built therein as shown in FIG. 3. The laser displacement meter 95 irradiates laser beams onto the tube 42. Light reflected on the tube 42 is condensed through a lens onto a light-receiving plane so as to be focused on it. The laser displacement meter 95 further measures an amount of displacement of a focal point on the light-receiving surface thereby to measure a variation in the inner diameter of the tube 42. More specifically, although the inner diameter of the tube 42 is $\phi 2.5$ before the experiment, the tube 42 is expanded and contracted with variations in the pressure since the blood equivalent 49 is force-fed through the tube in the experiment. Accordingly, even when the inner diameter of the tube 42 is $\phi 2.5$ in the natural state, there is a possibility that a mean value of the inner diameter of the tube under the experiment may not be $\phi 2.5$. In view of the problem, the inner diameter of the tube 42 is measured by the laser displacement meter 95 during the experiment, and a mean value of the inner diameter is obtained. When the obtained mean value is not $\phi 2.5$, the blood pressure and flow velocity conversion data measured using the tube 42 are amended or converted so that the data correspond to the inner diameter of $\phi 2.5$. As a result, an error in the inner diameter of the tube due to variations in the pressure applied to the tube 42 can be eliminated, whereupon an accurate blood pressure value can be obtained.

[0028] Further, the laser displacement meter 95 can be used to verify the blood pressure value obtained in any period (particularly in a non-rested state) from the equation (6). More specifically, the blood vessel is expanded or contracted in the non-rested state as compared with the rested state. For example, consider the case where a mean inner diameter value of the subject's blood vessel is $\phi 2.5$ in the rested state. In this case, when the mean value changes from $\phi 2.5$ to $\phi 4.0$ with the subject's change from the rested state to the non-rested state, a tube 42 having the inner diameter of $\phi 2.5$ is provided in the artificial model 40, and pressure is adjusted by a pump so that the mean value of the tube's inner diameter becomes $\phi 4.0$. A flow rate and pressure of the blood equivalent 49 are measured by the flow rate sensor 44 and the pressure sensor 48 respectively. The results of measurement are compared with the blood pressure value calculated on the basis of equation (6), whereby whether the blood pressure value is correct can experimentally be verified. Further, a correction factor or the like can be obtained when the blood pressure value calculated on the basis of equation (6) is compared with a blood pressure value actually measured in the experiment.

[0029] The blood pressure and flow velocity conversion data are based on data obtained when the tube has the inner diameter of $\phi 2.5$. However, in consideration of differences in the bodies of the subjects 5, blood pressure and flow velocity conversion data may be provided so as to correspond to different inner diameters of tubes. For example, the storage area 13 may store a plurality of data table, and tubes 42 for the respective sizes of $\phi 2.0$, $\phi 2.5$, $\phi 3.0$, etc. are prepared for the artificial model 40. Measurement is carried out with the tube 42 changed from one to another. The blood pressure data and flow velocity data are calculated for each tube 42 to be written onto the respective data table. Further, a blood vessel diameter measuring section serving as a measuring unit may be provided for measuring an inner diameter of blood vessel of the subject 5. In this case, a data table of tube diameter corresponding to the subject's blood vessel inner diameter is selected on the basis of the results of calculation. See step g in FIG. 6. Consequently, the differences in the bodies of the subjects 5 can be eliminated and accordingly, a more accurate blood pressure value can be obtained.

[0030] As the above-mentioned blood vessel diameter measuring section, the photoelectric sensor 26 may be attached to a finger tip so that light with a predetermined wavelength is irradiated onto a regular pulse in the finger tip. The blood vessel diameter measuring section detects the resultant transmitted light. In this case, output to be obtained corresponds to the variations in the blood vessel diameter when the transmitted light belongs to a wavelength range in which the light is absorbed into a component in the blood vessel such as hemoglobin. Further, the inner diameter of the blood vessel can be measured on the basis of the variations in the flow velocity V_t . More specifically, the flow

velocity value V_t varies with variations in the inner diameter of the blood vessel. The flow velocity is increased in a part of the blood vessel where the inner diameter thereof is reduced. The flow velocity is reduced in a part of the blood vessel where the inner diameter thereof is increased. Accordingly, when the flow velocity is measured at a plurality of parts of a single blood vessel, the inner diameter of the blood vessel can be obtained on the basis of the differences

5

[0031] The above-described biological data observation apparatus can be used in the following manner. The photoelectric sensor 26 is disposed on different parts of a single blood vessel of the subject 5. A photoelectric volume pulse wave is measured at each part by the light emitting element 26A and the light detecting element 26B. A blood flow rate is then calculated for every measured part by the CPU 12. If the blood vessel is narrowed by arteriosclerosis, the flow rate of blood is reduced to a large degree at the narrowed part of the vessel. Accordingly, arteriosclerosis can be detected when the flow rates of blood calculated by the CPU 12 are compared with one another. In order that a flow rate of blood may be obtained by calculation, the flow velocity is firstly calculated on the basis of the photoelectric volume pulse wave and flow velocity conversion data. The obtained flow velocity is multiplied by a sectional area of the blood vessel.

10

15

[0032] Further, the wrist band 21 of the pulse-wave measuring device 20 is modified so as to be fastened around the head and is set so that the photoelectric sensor 26 is directed to the skull. In this case, when light belonging to a predetermined wavelength range is irradiated from the light emitting element 26A of the photoelectric sensor 26, the irradiated light is transmitted through the skull so that the photoelectric volume pulse wave according to the blood flow rate in the blood vessel can be measured in a noninvasive manner. Additionally, when the photoelectric sensor 26 is used to irradiate light onto another artery such as the radial artery or antebrachial artery, a photoelectric volume pulse wave can be measured according to a change in the blood flow rate in the artery.

20

25

[0033] The photoelectric sensor 26 constitutes the measuring unit in the foregoing embodiment. In a second embodiment, a second photoelectric sensor 96 is further provided in addition to the photoelectric sensor 26. Furthermore, the flow velocity values V_o and V_t of the subject 5 are calculated on the basis of the flow velocity conversion data in the foregoing embodiment. In the second embodiment, however, the second photoelectric sensor 96 detects a plurality of photoelectric volume pulse waves, and the flow velocity values V_o and V_t are calculated on the basis of a phase difference between the detected photoelectric volume pulse waves. The other arrangement in the second embodiment is similar to that in the foregoing embodiment and accordingly, detailed description of the other arrangement will be eliminated. The photoelectric sensor 26 serves as a first photoelectric sensor in the invention.

30

35

[0034] The second photoelectric sensor 96 is applied around the wrist of the subject 5, for example, and comprises a single light emitting element 97 and a plurality of light detecting elements 98A, 98B and 98C. The light detecting elements 98A-98C are disposed at regular intervals L along the blood vessel and simultaneously detect light irradiated by the light emitting element 97 to be reflected (a transmitted light for convenience in explanation in FIG. 8). The interval L between the light detecting elements is set at a value ranging from several mm to several tens mm. Thus, when the interval between the light detecting elements is set at such a small value as mentioned above, a moving time required for the blood flow to move from the element 98A to the element 98C can be set at an equal value to a period of the photoelectric volume pulse wave. When the moving time of the blood flow is set in this manner, a moving time required for the blood flow to move between the light detecting elements can be obtained from a phase difference on graphs. FIGS. 9A to 9C illustrate transition of photoelectric volume pulse waves obtained from the light detecting elements 98A to 98C respectively. For example, reference symbols t_a , t_b and t_c designate peak values of the photoelectric volume pulse waves respectively. A time required for the blood flow to move from the light detecting element 98A to the light detecting element 98B is expressed as " t_a-t_b " and the distance between the elements 98A and 98B is L . Accordingly, a flow velocity value V_t can be obtained from the following equation (7):

40

45

$$V=(t_a-t_b)/L \quad (7)$$

[0035] The values V_o and V_t can be obtained when the phase difference between the photoelectric volume pulse waves at the measurement reference time and in any period is substituted for (t_a-t_b) in equation (7). Additionally, three light detecting elements 98A to 98C are provided in the second embodiment. A flow velocity value between the elements 98A and 98B is obtained, and a flow velocity between the elements 98B and 98C is also obtained. A mean value of both flow velocity values serves as a flow velocity value in the second embodiment.

50

55

[0036] On the other hand, the blood pressure value P_o at the measurement reference time can be obtained, as in the foregoing embodiment, on the basis of both converted pulse wave area S_o obtained from the photoelectric volume pulse wave and blood pressure conversion data. Accordingly, when the values P_o , V_o and V_t are obtained, a blood pressure variation amount ΔP and accordingly, a blood pressure value P_t in any period can be obtained on the basis of equation (5):

$$\Delta P = P_t - P_o = \rho / 2 (V_o^2 - V_t^2) \quad (5)$$

5 [0037] Furthermore, the inventors have found that there is a correlation between the flow velocity value V_t and a period of the photoelectric volume pulse wave detected by each of the photoelectric sensors 26 and 96. Accordingly, when turning our attention to the period of the photoelectric volume pulse wave (for example, t_w in FIG. 9B), the transition of the flow velocity value can be obtained from the period of the photoelectric volume pulse wave without provision of a plurality of light detecting elements.

10 [0038] Both foregoing embodiments are directed to the measurement of blood pressure of the subject 5. However, a blood flow rate of the subject 5 can also be calculated on the basis of the blood pressure and flow velocity conversion data, for example. More specifically, a pressure sensor serving as the blood pressure measuring section in the invention is provided as the measuring unit in stead of the photoelectric sensor 26. Firstly, a blood pressure value P_o is obtained from the pressure sensor at the measurement reference time and furthermore, a converted pulse wave area and accordingly flow velocity values S_o and V_o are calculated on the basis of the blood pressure and flow velocity conversion data. Continuously, in any period after start of the measurement, the value V_t is calculated by substituting values for P_t , P_o and V_o in equation (4) respectively. The value ϕ_t is further calculated by substituting values for ϕ_t , V_o and V_t . Consequently, a blood flow rate of the subject 5 in any period can be obtained on the basis of the inner diameter of the blood vessel of the subject 5 and the flow velocity V_t of the blood.

20 [0039] A third embodiment of the invention will now be described with reference to FIGS. 10 to 12B. In the third embodiment, a body motion sensor 51 serving as the measuring unit is added for detecting a slight motion of the subject 5. Furthermore, a pulse wave regenerating circuit 57 and a body motion detecting section 59 are added to the data processing device 10. The body motion detecting section 59 constitutes part of the operational unit in the invention. A substituting process which will be described in detail later is carried out on the basis of determination of the waveform data of the photoelectric volume pulse wave and the results of determination. The other arrangement in the third embodiment is similar to that in the first embodiment and accordingly, detailed description of the other arrangement will be eliminated.

25 [0040] The body motion sensor 51 is disposed side by side with the photoelectric sensor 26 and comprises a blue LED (light emitting element) irradiating light with a wavelength of 420 nm, for example and a phototransistor (light detecting element) detecting the light reflected. The light emitted from the blue LED is reflected on a skin surface of the subject, and output of the phototransistor is detected as slight body movement of the subject 5.

30 [0041] The photoelectric sensor 26 is connected via an amplifier 52 to a low-pass filter 53 and a high-pass filter 54 so that output of the sensor 26 is supplied to the data processing device 10. The low-pass filter 53 cuts off frequencies at or below 30 Hz in order to eliminate low-frequency components as noise. Further, the high-pass filter 54 cuts off high-frequency components or frequencies at or above 150 Hz. The body motion sensor 51 is connected via an amplifier 55 to an active filter 56 (bandpass filter). The active filter 56 transmits a predetermined band of frequencies to the data processing device 10 while rejecting all other frequencies.

35 [0042] The data processing device 10 comprises a multiplexer 58, a pulse wave reproducing circuit 57 and a body motion detecting section 59 in addition to the storage area 13, CPU 12 and A/D converter 12. An input signal from the photoelectric sensor 26 is supplied via the pulse wave regenerating circuit 57 to the multiplexer 58 and CPU 12. An input signal from the body motion sensor 51 is supplied via the body motion detecting section 59 and multiplexer 58 to CPU 12.

40 [0043] The pulse wave reproducing circuit 57 is connected further to the body motion detecting section 59. In the pulse wave reproducing circuit 57, an output waveform of the body motion sensor 51 is subtracted from an output waveform delivered from the photoelectric sensor 26 to be passed through the filters 53 and 54. Thus, the pulse wave regenerating circuit 57 generates a waveform in which the body motion components (particularly slight body motion of the subject) have been eliminated from the output of the photoelectric sensor 26. The processing carried out by the pulse wave reproducing circuit 57 constitutes a modifying process in the invention. Output data of the photoelectric sensor 26 is thus processed through the noise eliminating process by the low-pass and high-pass filters 53 and 54 and the modifying process in which the body motion sensor 51 detects slight body motion of the subject 5 and body motion components are subtracted from the output of the photoelectric sensor 26, whereupon only pure pulse wave components are continuously extracted. Consequently, since error components are eliminated from the photoelectric volume pulse waveform, an accurate photoelectric volume pulse wave can be obtained.

45 [0044] Determination of the photoelectric volume pulse wave by the data processing device 10 will now be described with reference to FIG. 11. In the third embodiment, the determination of the photoelectric volume pulse wave depends upon whether a period of the photoelectric volume pulse wave is within a predetermined allowed range (step j). The predetermined allowed range is a normal range of the period of the photoelectric volume pulse wave, for example, a range of 0.75 to 1.5 sec. When a large body motion occurs in the subject 5 during measurement of a photoelectric

volume pulse wave, the waveform of the photoelectric volume pulse wave disturbs such that the period thereof is out of the allowed range. When determining that the period of the photoelectric volume pulse wave is within the allowed range, the data processing device 10 advances to a first blood pressure calculating step (step k), whereas the data processing device 10 advances to a step in which the substitution of the photoelectric volume pulse wave is carried out (step n) when determining that the period of the photoelectric volume pulse signal is out of the allowed range.

[0045] In the first blood pressure calculation step, a blood pressure variation amount ΔP and a blood pressure value P_t of the subject in the non-rested state are calculated on the calculated basis of the flow velocity value V_o and blood pressure value P_o in the rested state, the peak value of the photoelectric volume pulse wave etc. The data processing device 10 then collates the obtained blood pressure value P_t with the blood pressure reference value, thereby checking it (step m). The blood pressure reference value is a range of blood pressure obtained by a normal measurement (for example, range of 50 to 140 mmHg). When the obtained blood pressure value is within the reference value range, the data processing device 10 determines that the measurement has normally been carried out, displaying the transition of blood pressure P_t . On the other hand, when the obtained blood pressure value is out of the reference value range, the data processing device 10 determines that measurement is erroneous, returning to the pulse wave measuring step (step a) for re-calculation of the blood pressure value P_t .

[0046] When determining that the period of photoelectric volume pulse wave is out of the allowed range, the data processing device 10 executes a substitution processing for the photoelectric volume pulse wave. In the substitution processing, as shown in FIGS. 12A and 12B, a mean waveform model (a hatched portion in FIG. 12B) which will be described later is substituted for abnormal wave form part of the measured photoelectric volume pulse wave or part of waveform data out of the allowed range. Thereafter, a blood pressure value is calculated in a second blood pressure value calculating step (step o). More specifically, regarding part of the waveform data within the allowed range, a flow velocity value V_o and blood pressure value P_o in the subject's rested state are calculated, and a blood pressure variation amount ΔP is calculated on the basis of a peak value of the photoelectric volume pulse wave etc. A blood pressure value P_t in the subject's non-rested state is lastly calculated. Regarding the part of waveform data out of the allowed range, a blood pressure variation amount ΔP and a blood pressure value P_t in the subject's non-rested state are calculated on the basis of the substituted peak value of photoelectric volume pulse wave. Thereafter, the data processing device 10 advances to step m to check the blood pressure value.

[0047] The mean waveform model is calculated on the basis of waveform data of the subject 5 within the allowed range. More specifically, waveform data of photoelectric volume pulse wave is supplied into the storage area 13 at any time after start of measurement. On the other hand, CPU 12 calculates a mean value on the basis of a peak value and period etc. regarding the waveform data which has been measured until detection of waveform data which is out of the allowed range. CPU 12 then obtains a mean wave form model based on the results of calculation.

[0048] As obvious from the foregoing, since the data processing device 10 carries out determination of the photoelectric volume pulse wave, error due to such a large body motion that cannot be detected by the body motion sensor 51 can be eliminated and furthermore, an accurate photoelectric volume pulse wave can be obtained. Accordingly, a reliable diagnosis can be made when data analysis (for example, calculation of a mean blood pressure value) is carried out about a blood pressure value after detection of the blood pressure value.

[0049] The photoelectric volume pulse wave is measured at the wrist of the subject 5 (measurement part) in the embodiment. However, an error sometimes occurs in the measurement because a vertical distance between the measurement part and the heart of the subject differs depending upon an angle of the subject's arm. An angular compensation can be made by the CPU 12 when an angle sensor is provided for detecting an angle of the subject's arm as a measure to prevent the foregoing error.

[0050] The data processing device 10 can calculate an oxygen saturation of arterial blood SaO_2 as well as the above-described blood pressure value. A calculating procedure will be described with reference to FIG. 13. The data processing device 10 calculates a blood flow rate Q on the basis of the blood pressure and flow velocity conversion data and photoelectric volume pulse wave and further calculates a pulsation E on the basis of a period of the photoelectric volume pulse wave. The data processing device 10 further calculates a cardiac output Co and a cardiac index Cx from the following equations (8) and (9):

$$Co = E \times Q \quad (8)$$

$$Cx = Co / S \quad (9)$$

where E is pulsation and S is body surface area ($S=3.4L/min/m^2$ in the embodiment). The data processing device 10 further calculates an arterial oxygen content CaO_2 and a mixed venous oxygen content CvO_2 from a known algorithm on the basis of the photoelectric volume pulse wave and further calculates an oxygen saturation of arterial blood SaO_2

from the following equation (10) :

$$SaO_2 = (CaO_2 - CvO_2) \times Cx \quad (10)$$

5 [0051] A fourth embodiment of the invention will be described with reference to FIGS. 14 to 21. Although only the pulse-wave measuring device 20 constitutes the measuring unit and measures mainly a blood pressure in the first embodiment, the measuring unit comprises a sweat amount measuring device 70 serving as a sweat amount measuring section and a temperature sensor 60 for detecting a skin temperature and serving as skin temperature measuring section, in addition to the pulse-wave measuring device 20. A degree of anesthesia, which will hereinafter be referred to as "anesthesia depth"), is calculated on the basis of the results of detection by the afore-mentioned devices. The other arrangement in the fourth embodiment is similar to that in the first embodiment and accordingly, detailed description of the other arrangement will be eliminated. Biological data obtained by each measuring devices will hereinafter be referred to as "primary biological data."

15 [0052] Firstly, the sweat amount measuring device 70 will be described. The sweat amount measuring device 70 has the same operating principle as a sweat amount measuring device disclosed in JP-A-10-262958 filed by the assignee of the present application. More specifically, the sweat amount measuring device 70 includes a capsule 71 having a recess 72. The capsule 71 is attached to the skin surface of the subject with an opening of the recess 72 being closed by the skin surface. The capsule 71 includes a side formed with a supply opening 73 and a discharge opening 74 both communicating with the recess 72. A low-humidity nitrogen gas reserved in a cylinder (not shown) is supplied at a predetermined flow rate into the recess 72 through a rubber tube 73A communicating with the supply opening 73. On the other hand, a humidifier (not shown) is provided in the middle of a rubber tube 74A communicating with the discharge opening 74 for measuring a humidity of air discharged. Furthermore, the capsule 71 includes a thermometer and a heater-cooler (for example, Peltier element) both built therein so that an interior of the recess 72 is maintained at a constant temperature. The sweat amount measuring device 70 has an output line connected via the A/D converter 11 to the CPU 12 so that output of the humidifier and thermometer is supplied into the data processing device 10. The data processing device 10 executes an operation on the basis of the supplied output, obtaining a sweat amount of the subject (sweat amount data).

25 [0053] The temperature sensor 60 for the detection of skin temperature may be of the thermal expansion type, thermocouple type or thermistor type. The temperature sensor 60 is attached to an arm of the subject 5 etc. for measuring purpose, thereby detecting a skin temperature of the subject. The temperature sensor 60 also has an output line connected via the A/D converter to the CPU 12. Output of the temperature sensor 60 is supplied into the data processing device 10, which then executes an operation on the basis of the supplied output to obtain a skin temperature of the subject 5 (skin temperature data).

30 [0054] Furthermore, the data processing device 10 calculates peak value data regarding a peak value and pulsation data on the basis of the photoelectric volume pulse wave obtained from the pulse-wave measuring device 20. The data processing device 20 further calculates a flow velocity value on the basis of flow velocity conversion data and further calculates an oxygen saturation of arterial blood (oxygen saturation data) on the basis of the obtained flow velocity value. The data processing device 10 calculates an anesthesia depth T based on the obtained primary biological data.

35 [0055] Two methods for measurement of anesthesia depth T will be described. In a first method, the data processing device 10 obtains composite data from the primary biological data and calculates an anesthesia depth T based on the obtained composite data. Firstly, peak value data y1 serves as reference data. The other primary biological data (sweat amount data y2, oxygen saturation data y3, skin temperature data y4 and pulsation data y5) are added to the reference data on the basis of an algorithm as shown in the following equation (11) so that composite data A is obtained:

$$A = h1 \times y1 + h2 \times F(y2) + h3 \times G(y3) + h4 \times H(y4) + h5 \times I(y5) \quad (11)$$

40 [0056] where y1 is peak value data, y2 is sweat amount data, y3 is oxygen saturation data, y4 is skin temperature data, y5 is pulsation data, h1 to h5 are constants, and F to I are functions. The peak value data is selected as the reference data as described above. The reason for this selection is that the peak value data shows a best correlation with the degree of anesthesia when the anesthesia depth is represented as numeric.

45 [0056] Composite data is obtained as will be described below. Firstly, the sweat amount data y2 and peak value data are formed into composite data. More specifically, composite data A2 of the sweat amount data y2 and peak value data y1 is obtained from equation (11):

EP 1 317 902 B1

$$A2=h1 \times y1+h2 \times F(y2)$$

Since

$$F(y2)=1-\text{EXP}(-h6 \times y2),$$

$$A2=h1 \times y1+h2 \times (1-\text{EXP}(-h6 \times y2))$$

where h6 is a constant. In the obtained composite data A2 of the peak value data y1 and the sweat amount data y2, transition of the peak value data serves as a base, to which transition of the sweat amount data y2 is added, as shown in FIG. 16C. More specifically, small transition in the sweat amount data y2 have less effect on transition in the peak value data y1, and only a large transition in the sweat amount data y2 appears on the peak value data y1 with a reduced scale (hatched portion in FIG. 16C).

[0057] Each of the oxygen saturation data y3, skin temperature data y4 and pulsation data y5 is synthesized into the composite data A2 as in the same manner as described above, whereupon the composite data is calculated. See FIG. 17. The anesthetic depth T is calculated on the basis of the composite data obtained as described above:

$$T=At/Ao \times 100 \quad (12)$$

where Ao is a reference value of composite data A (the value before application of anesthesia), and At is a value At of the composite data A after application of anesthesia. The anesthetic depth T is thus obtained as an absolute value on the basis of a ratio of the reference value Ao of the composite data A to the value At of composite data after application of anesthesia. Furthermore, transition of the calculated anesthesia depth is displayed on the monitor 30 with the composite data A.

[0058] In the fourth embodiment, a plurality of primary biological data closely related with a degree of anesthesia are put together into a signal data for the purpose of measuring the anesthesia depth. Accordingly, since a plurality of primary biological data are compensated by one another, a more accurate anesthetic depth T can be obtained as compared with the case where the anesthetic depth is calculated on the basis of a single primary biological data.

[0059] The calculated composite data A is stored in the storage area 13. Even if measurement of the primary biological data about the subject 5 starts after application of anesthesia, the anesthetic depth T can be calculated. More specifically, the data processing device 10 collates a change pattern (transition from start of measurement to stabilization of composite data) of composite data B calculated on the basis of the primary biological data with change patterns of accumulated previous composite data, thereby extracting similar composite data R. The reference value Ro of the extracted composite data R is substituted for the composite data B. The anesthetic depth of the subject 5 is calculated on the basis of the substituted reference value Ro and a value Bt of the composite data B:

$$T=Bt/Ro \times 100$$

[0060] In the embodiment, a reference value Ao used for calculation of the anesthetic depth is the one obtained after application of anesthesia. However, any value composing composite data A maybe used. Foreexample, a peak value obtained after application of anesthesia may be used.

[0061] A second calculating method will now be described with reference to FIGS. 18A to 20. In this method, an anesthetic depth is calculated for each primary biological data. Thereafter, the anesthetic depth values calculated on the basis of the respective primary biological data are added together, so that a synthetic anesthetic depth is obtained. Calculation exemplified here is based on the peak value data y1, sweat amount data y2, oxygen saturation data y3 and pulsation data y5. However, the calculation may be based on only the peak value data y1, sweat amount data y2 and pulsation data y5.

[0062] Firstly, when the peak value data y1, sweat amount data y2, oxygen saturation data y3 and pulsation data y5 are supplied into the data processing device 10, the CPU 12 calculates a mean value of each primary biological data before application of anesthesia, that is, a mean value y1o of peak value data y1, mean value y2o of sweat amount data y2, mean value y3o of oxygen saturation data y3 and mean value y5o of pulsation data y5. Thereafter, the CPU 12 calculates a pulse-wave anesthetic depth T1, sweat-amount anesthetic depth T2 and oxygen-saturation anesthetic depth T3 on the basis of the respective primary biological data according to the respective equations:

EP 1 317 902 B1

$$T1=(y1t \times y5t - k1 \times y1o \times y5o) / (k2 \times y1o \times y5o) \quad (13)$$

$$T2=(y2t - k3 \times y2o) / (k4 \times y2o) \quad (14)$$

$$T3=(y3t - k5 \times y3o) / (k6 \times y3o) \quad (15)$$

10 where $k1$ to $k6$ are constants, $y1o$ is a mean value of peak value data $y1$ before application of anesthesia, $y1t$ is a value of peak value data $y1$ at any time, $y5o$ is a mean value of pulsation data $y5$ before application of anesthesia, $y5t$ is a value of pulsation data $y5$ at any time, $y2o$ is a mean value of sweat amount data $y2$ before application of anesthesia, $y2t$ is a value of sweat amount data $y2$ at any time, $y3o$ is a mean value of oxygen saturation data $y3$ before application of anesthesia, and $y3t$ is a value of oxygen saturation data $y3$ at any time.

15 **[0063]** Successively, the pulse-wave anesthetic depth $T1$, sweat-amount anesthetic depth $T2$ and oxygen-saturation anesthetic depth $T3$ are added together, whereupon an anesthetic depth T ($T=T1+T2+T3$) can be calculated. In this case, too, a plurality of primary biological data related with an anesthetic depth are put together into a single data in the same manner as described above. Accordingly, since a plurality of primary biological data are compensated with one another, a more accurate anesthetic depth T can be obtained as compared with the case where the anesthetic depth is calculated on the basis of a single primary biological data.

20 **[0064]** Transition of the obtained anesthetic depth T is displayed on the monitor 30 (see FIG. 20). While confirming transition of anesthetic depth T on the monitor 30, the doctor adjusts an amount of anesthesia applied to the subject 5. The doctor starts operation when understanding that the anesthetic depth T is stable at a suitable value. On the other hand, in a case where the subject 5 has an abnormal symptom, the doctor learns the abnormal symptom when viewing transition of anesthetic depth on the monitor 30. In this case, when alarming means is provided in the data processing device 10, the doctor can be informed of the abnormal symptom of the subject 5 without depending upon the contents displayed on the monitor 30.

25 **[0065]** An electrocardiograph 80 serving as a heartbeat measuring section and an electroencephalograph 90 serving as a brain wave measuring section may be provided in addition to the above-described measuring unit as shown in FIG. 21. The electrocardiograph 80 includes electrodes applied to the body surface of the subject 5 for detecting a feeble electric signal generated when the heart beats. The electric signal is amplified by an amplifier to be delivered as heart-beat data $y6$.

30 **[0066]** The electroencephalograph 90 has the same operating principle as the electrocardiograph 80 and includes electrodes applied to the head of the subject 5 for detecting a feeble electric signal generated in the brain as the result of working of the brain. The signal is amplified by the amplifier to be delivered as brain wave data $y7$.

35 **[0067]** The data processing device 10 calculates the anesthetic depth T based on the seven primary biological data, that is, the peak value data $y1$, sweat amount data $y2$, oxygen saturation data $y3$, skin temperature data $y4$, pulsation data $y5$, heart-beat data $y6$ and brain wave data $y7$. Further accurate anesthetic depth T can be calculated since the heart beat and brain wave are parameters closely related with the anesthetic depth T .

40 **[0068]** A fifth embodiment of the invention will be described with reference to FIGS. 22A and 22B. Although the anesthetic depth T of the subject 5 is calculated in the fourth embodiment, a total calorie of the subject 5 is calculated.

45 **[0069]** In the fifth embodiment, the biological data observation apparatus includes a temperature sensor 60 serving as the measuring unit and detecting a skin temperature. On the other hand, the storage area 13 stores body surface area conversion data which will be described below. The body surface area conversion data contains a correlation between a person's figure and body surface area. For example, a person's body surface area is calculated when data of height, weight, age and sex of the person is entered. Accordingly, when a skin temperature of the subject 5 is measured by the temperature sensor 60 and a mean value of the measured skin temperatures per predetermined time is calculated by the CPU, a total calorie of the subject 5 can be calculated on the basis of the mean skin temperature value and the body surface area.

50 **[0070]** Furthermore, when the pulse-wave measuring device 20 and the temperature sensor 60 are used together, the skin temperature of the subject 5 can also be calculated on the basis of the photoelectric volume pulse wave. More specifically, the inventors have found that a skin temperature has a relation with a blood flow rate. Accordingly, a photoelectric volume pulse wave is measured by the pulse wave measuring device 20 so that a peak value of the photoelectric volume pulse wave is obtained. A flow velocity value is calculated on the basis of flow velocity conversion data, and a blood flow rate is calculated. Skin temperature and blood flow conversion data is calculated on the obtained blood flow rate and skin temperature (see FIGS. 22A and 22B.). The skin temperature and the blood flow rate are correlated with each other in the calculated conversion data. The skin temperature and blood flow conversion data is written into the storage area 13 for every subject 5. As a result, after the conversion data has been written, the skin

temperature of the subject 5 can be calculated on the basis of the skin temperature and blood flow conversion data written in the storage area 13 when the photoelectric volume pulse wave is measured by the pulse wave measuring device 20 without direct measurement by the temperature sensor 60. When the skin temperature and blood flow conversion data is written into the storage area 13, it is desirable that the data should be written together with data of environment (humidity, temperature, etc.) at the time of measurement. Consequently, factors which result in errors are eliminated and accordingly, accurate data can be obtained.

[0071] Furthermore, the inventors have found that a sweat amount also has a relation with a blood flow rate. Accordingly, a sweat amount of the subject 5 can be calculated without direct measurement of sweat amount when both primary biological data of sweat amount and blood flow rate are obtained and sweat amount and blood flow rate conversion data is calculated on the basis of the primary biological data.

[0072] In modified forms, an animal may be used although the artificial measurement human body model 40 is used in the first embodiment. Furthermore, the blood flow rate per heart-beat is measured by the photoelectric sensor 26 in the first embodiment. However, the heart-beat may be measured using laser beams, other light sources or an ultrasonic sensor or pressure sensor.

[0073] In the first embodiment, the blood flow rate of the subject 5 is measured by the photoelectric sensor 26 of the fixed type in order that the arteriosclerosis may be detected. However, a photoelectric sensor of the scanner type may be used, instead.

[0074] The photoelectric sensor 26 of the single waveform type is used in each of the first to fifth embodiments. However, the photoelectric sensor may be of multiple wavelength type (dual or triple wavelength).

Claims

1. A biological data observation apparatus comprising:

a measuring unit including at least a photoelectric sensor (26) including a light emitting element (26A) for emitting light with a predetermined wavelength onto a blood vessel of a subject (5) and a light detecting element (26B) for detecting, as a photoelectric volume pulse wave, a change in an amount of transmitted or reflected light resulting from the light emitted from the light emitting element;

an operational unit (10) into which a result of measurement by the measuring unit is supplied so that the operational unit (10) carries out an operational process based on the supplied result of measurement;

a storage area (13) storing data of the result of measurement or the like; and

a display unit (30) displaying a result of calculation performed by the operational unit (10),

the storage area (13) stores blood pressure conversion data correlating a pulse wave area and a blood pressure value in order that a pulse wave area may be converted to a blood pressure value as an absolute value, the pulse wave area being obtained by integrating a waveform of the photoelectric volume wave per heartbeat; and

the operational unit (10) calculates the pulse wave area on the basis of the photoelectric volume pulse wave obtained from the subject (5) and further calculates a blood pressure value of a subject (5) on the basis of the calculated pulse wave area and the blood pressure conversion data, **characterized in that:**

the blood pressure conversion data is calculated on the basis of a measuring artificial human body model (40) including a liquid feeding unit (43) pressure-feeding blood or an equivalent (49) thereof per heartbeat time obtained while a sampling object having a predetermined form is in a rested state, the liquid feeding unit (43) having a pressure adjustable in pressure feed, a transfer tube (42) through which the blood or equivalent thereof is transferred, the transfer tube (42) having an inner diameter substantially equal to an inner diameter of a blood vessel of the sampling object near which blood pressure is measured by the photoelectric sensor (26) while the object (5) is in the rested state, a pressure measuring section measuring pressure of the blood or equivalent thereof in the transfer tube, and a photoelectric sensor irradiating light with a predetermined wavelength onto the transfer tube for detecting, as a photoelectric volume pulse wave, a change in an amount of transmitted or reflected light resulting from the irradiated light, and wherein the pressure applied to the blood or equivalent thereof during the pressure feed is varied into various values, and the photoelectric volume pulse wave and the pressure applied to the blood or equivalent thereof during the pressure feed are measured by the photoelectric sensor and the pressure measuring section respectively so that the pulse wave area per heartbeat time and the pressure value of the blood or equivalent (49) thereof both obtained by the photoelectric sensor (26) and the pressure measuring section respectively are correlated with each other.

2. An apparatus according to claim 1, **characterized in that** the measuring model (40) has a flow rate measuring section measuring a flow rate of the blood or equivalent (49) thereof per heartbeat time, the storage area (13) stores flow velocity conversion data in which a flow velocity value obtained by dividing a flow velocity measured by the flow rate measuring section by a sectional area of the transfer tube (42), and the pulse wave area of the photoelectric volume pulse wave measured relative to the transfer tube (42), the flow velocity and the pulse wave area being correlated with each other, the measuring unit (26) calculates a pulse wave area S_o on the basis of a photoelectric volume pulse wave obtained from the subject that is in a reference state prior to start of measurement, the measuring unit (26) further calculating a reference pressure value P_o and a reference flow velocity value V_o on the basis of the obtained pulse wave area S_o , blood pressure conversion data, flow velocity conversion data, the measuring model (40) further calculating, from an algorithm, a blood pressure variation amount ΔP indicative of a variation in a blood pressure in a predetermined time after calculation of the reference pressure value P_o and the reference flow velocity value V_o on the basis of a change rate in a peak value of the photoelectric volume pulse wave and the reference flow velocity value V_o at the reference time, the algorithm being determined so that a flow velocity V_t at any time is calculated by substituting the flow velocity value V_o , a peak value D_o of the photoelectric volume pulse wave, a peak value D_t of the photoelectric volume pulse wave at any time, and a constant k are substituted into equation (a) and the blood pressure variation amount ΔP is obtained by substituting the reference flow velocity value V_o at the reference time, a flow velocity V_t at any time, and a blood density ρ into equation (b):

$$V_t = (D_o / k D_t)^2 \times V_o \quad (a)$$

$$P_t - P_o = \rho / 2 (V_o^2 - V_t^2) \quad (b)$$

3. A biological data observation apparatus according to any one of the preceding claims, **characterized in that** a plurality of the transfer tubes (42) are provided having different diameters according to differences in individual subjects (5), the blood pressure conversion data and the flow velocity conversion data being calculated for each transfer tube;

the storage area (13) stores a plurality of data tables so that the blood pressure conversion data and the flow velocity conversion data with respect to the transfer tubes (42) with the different diameters are written into the data tables respectively;

the measuring unit (26) includes a blood vessel diameter measuring section measuring a diameter of a blood vessel of the subject (5) in a rested state in addition to the photoelectric sensor (26); and

based on results of measurement by the blood vessel diameter measuring section, the operational unit (10) selects the data table storing the blood pressure conversion data and the flow velocity conversion data with respect to the transfer tube (42) with the diameter approximate to the measured diameter of blood vessel of the subject (5).

4. A biological data observation apparatus according to any one of the preceding claims, **characterized in that:**

the measuring unit (26) further has another photoelectric sensor (96) including a single light emitting element (97) and a plurality of light detecting elements (98A, 98B, 98C) which are disposed along the blood vessel of the subject (5) so as to be spaced each one from the other;

the operational unit (10) calculates a pulse wave area S_o on the basis of a photoelectric volume pulse wave obtained from the subject (5) who is temporarily under the measuring reference state prior to measurement, further calculates a blood pressure value P_o on the basis of the calculated pulse wave area S_o and the blood pressure conversion data, and still further calculates a flow velocity V_o in the measuring reference state on the basis of a phase difference between the photoelectric volume pulse waves obtained from the light detecting elements and distances between the light detecting elements;

the operational unit (10) calculates a flow velocity V_t in any period on the basis of a phase difference between the photoelectric volume pulse waves obtained from the light detecting elements (98A, 98B, 98C) and distances between the light detecting elements (98A, 98B, 98C), and substitutes the flow velocity values V_o and V_t and the blood density ρ for those in the equation (b) thereby to calculate a blood pressure variation amount ΔP representative of variations in the blood pressure in any period:

$$\Delta P = P_t - P_o = \rho / 2 (V_o^2 - V_t^2) \quad (b)$$

EP 1 317 902 B1

and calculates the blood pressure value P_t in any period from the calculated blood pressure variation amount ΔP and the blood pressure value P_o at the measurement reference time.

- 5 5. A biological data observation system according to any one of the preceding claims, **characterized in that:**

the measuring unit (26) further includes a sweat amount measuring section measuring an amount of sweat given forth by the subject (5) and a skin temperature measuring section measuring a temperature of a skin of the subject;

10 the operational unit (10) calculates a pulse wave area on the basis of the supplied the photoelectric volume pulse wave of the subject (5) when the photoelectric volume pulse wave of the subject (5) is supplied thereto, further calculating an amount of blood flowing in the subject (5) on the basis of the calculated pulse wave area and the flow velocity conversion data and further calculates sweat amount conversion data correlating the amount of blood flowing and the sweat amount with each other from the calculated amount of blood flowing and the sweat amount measured by the sweat amount measuring section and skin temperature conversion data correlating the amount of blood flowing and the skin temperature with each other on the basis of the calculated amount of blood flowing and the skin temperature measured by the sweat amount measuring section, the sweat amount conversion and skin temperature conversion data being calculated for every subject (5); and

15 the operational unit (10) calculates mean values of the sweat amount and skin temperature of each subject (5) on the basis of the sweat amount and skin temperature conversion data and the amount of blood of the subject (5) without using the sweat amount and skin temperature measuring sections after the sweat amount and skin temperature data have been written into the storage area (13).

- 25 6. A biological data observation apparatus according to any one of the preceding claims, **characterized in that:**

the storage area is written with body surface area conversion data which correlates personal form data including data of personal height, weight, age, sex, and the like and data of body surface area with each other so that a body surface area of the subject (5) is calculated; and

30 when at least one piece of personal form data regarding the subject (5) has been supplied to the operational unit (10), the operational unit (10) calculates a body surface area of the subject (5) on the basis of the supplied personal form data and the body surface area conversion data, the operational unit (10) further calculating calorie consumption required of the subject (5) on the basis of the calculated body surface area or the skin temperature and a mean value thereof.

- 35 7. A biological data observation apparatus according to any one of the preceding claims, **characterized in that:**

the storage area (13) includes a waveform data storage section storing waveform data of the supplied photoelectric volume pulse wave;

40 the operational unit (10) sets an allowed range the waveform data normally takes, based on the waveform data accumulated in the waveform data storage section;

the operational unit determines whether new waveform data is within the allowed range upon supply of the waveform data thereto; and

45 when part of the waveform data is out of the allowed range, the operational unit (10) carries out a substituting process in which any waveform data is substituted for said part of the waveform data, said any waveform data being measured until the waveform data out of the allowed range has been detected from start of measurement and determined to be within the allowed range.

- 50 8. A biological data observation apparatus according to claim 7, **characterized in that** the operational unit (10) calculates the allowed range on the basis of a period of past waveform data written onto the waveform data storage section.

- 55 9. A biological data observation apparatus according to claim 7 or 8, **characterized in that** in the substituting process, the operational unit (10) calculates a mean waveform model on the basis of the periods and peak values of the waveform data measured until the waveform data out of the allowed range has been detected from start of measurement and determined to be within the allowed range.

10. A biological data observation apparatus according to any one of the preceding claims, **characterized in that:**

EP 1 317 902 B1

the measuring unit (26) includes a body motion sensor irradiating light having a wavelength shorter than a wavelength of the light irradiated by the photoelectric sensor (26) in order to continuously detect an amount of light reflected on the skin surface of the subject (5); and
the operational unit (10) carries out a modifying process in which an output waveform of the body motion sensor is subtracted from an output waveform of the photoelectric sensor (26) in order that a measurement error due to body motion of the subject (5) may be eliminated.

11. A biological data observation apparatus according to any one of the preceding claims, **characterized in that** in addition to the photoelectric sensor (26), the measuring unit (26) further includes at least any one of:

a sweat amount measuring section (70) measuring an amount of sweat given forth by the subject (5);
a skin temperature measuring section (60) measuring a temperature of a skin of the subject (5);
an arterial oxygen saturation measuring section measuring an arterial oxygen saturation of the subject (5);
a heartbeat measuring section (80) measuring a heartbeat of the subject; and
a brain wave measuring section (90) measuring a brain wave of the subject; and further **in that**:
the operational unit (10) calculates an anesthetic depth of the subject on the basis of primary biological data measured by the photoelectric sensor (26) and said at least any one of the measuring sections selected.

12. A biological data observation apparatus according to any one of the preceding claims, **characterized in that**:

the storage area (13) stores data of an algorithm synthesizing different pieces of primary biological data so that a temporal transition is obtained, and the operational unit (10) synthesizes a plurality of pieces of primary biological data obtained by the measuring unit (26), on the basis of the algorithm, thereby calculating composite data A, the operational unit (10) further selecting, as a reference value Ro, a value at a time approximately before or immediately after application of anesthesia from the calculated composite data A and compares a value At of the composite data A at a time after selection of the reference value Ao, thereby calculating an anesthetic depth.

13. A biological data observation apparatus according to any one of the preceding claims, **characterized in that**:

the storage area stores data of change patterns of the composite data A;
when measurement of primary biological data of the subject (5) is started after a time when the reference value Ao is to be selected, the operational unit (10) collates a change pattern of composite data B based on said biological data with a change pattern of past composite data stored in the storage area (13) thereby to extract similar composite data R and substitute the composite data B for a reference value Ro of the composite data R, the operational unit (10) further calculating an anesthetic depth of the subject (5) on the basis of the substituted reference value Ro and a value Bt of the composite data B.

14. A biological data observation apparatus according to any one of the preceding claims, **characterized in that**:

the measuring unit (26) includes the photoelectric sensor (26) and the sweat amount measuring section (70); and
the operational unit (10) incorporates peak value data y1 of the photoelectric volume pulse wave obtained from the photoelectric sensor (26), heartbeat data y5 and sweat amount data y2 obtained from the sweat amount measuring section (70) thereby to calculate a mean value y1o of the peak value data in a predetermined period before application of anesthesia, a mean value y5o of the heartbeat data y5 in the predetermined period and a mean value y2o of the sweat amount data y2 in the predetermined period, the operational unit (10) further obtaining a pulse-wave anesthetic depth T1 and a sweat amount anesthetic depth T2 from following equations (13) and (14) respectively on the basis of the mean values y1o, y5o and y2o and a value y1t of the peak value data y1 in a predetermined period after application of anesthesia, a value y5t of the heartbeat data y5 in the predetermined period and a value y2t of the sweat amount data y2, further calculating an anesthetic depth T (T=T1+T2) on the basis of the obtained pulse-wave anesthetic depth T1 and sweat amount anesthetic depth T2:

$$T1=(y1t \times y5t - k1 \times y1o \times y5o) / (k2 \times y1o \times y5o) \quad (13)$$

$$T2=(y2t-k3 \times y2o)/(k4 \times y2o) \quad (14)$$

where k_1 , k_2 and k_3 are constants.

5
15. A biological data observation apparatus according to any one of the preceding claims, **characterized in that** the operational unit (10) calculates a cardiac output and arterial oxygen saturation on the basis of the photoelectric volume pulse wave obtained by the photoelectric sensor and blood pressure conversion data.

10
16. An apparatus according to any one of the preceding claims, **characterized in that:**

a storage area (13) stores blood pressure and blood flow conversion data in which the blood pressure and an amount of blood flow are correlated with each other; and

15
the operational section (10) calculates a blood flow amount of the subject (5) from a blood pressure value of the subject (5) and the blood pressure and blood flow conversion data.

Patentansprüche

20
1. Vorrichtung zur Beobachtung biologischer Daten, umfassend:

eine Meßeinheit, beinhaltend wenigstens einen photoelektrischen Sensor (26), beinhaltend ein Licht emittierendes Element (26A) zum Emittieren von Licht mit einer vorbestimmten Wellenlänge auf ein Blutgefäß eines Subjekts bzw. einer Person (5) und ein Licht detektierendes Element (26B) zum Detektieren, als eine photoelektrische Volumenpulswelle, einer Änderung in einer Größe von transmittiertem oder reflektiertem Licht, das aus dem Licht resultiert, das von dem Licht emittierenden Element emittiert wurde;

25
eine Betätigungs- bzw. Betriebseinheit (10), in welche ein Ergebnis einer Messung durch die Meßeinheit so zugeführt ist, daß die Betriebseinheit (10) ein Betriebsverfahren basierend auf dem zugeführten Meßergebnis ausführt;

30
einen Speicherbereich (13), der Daten des Ergebnisses einer Messung oder dgl. speichert; und

eine Anzeigeeinheit (30), die ein Ergebnis einer Berechnung anzeigt, die durch die Betriebseinheit ausgeführt wurde (10);

wobei der Speicherbereich bzw. die Speichereinheit (13) Blutdruckumwandlungsdaten speichert, die einen Pulswellenbereich und einen Blutdruckwert korrelieren, so daß ein Pulswellenbereich in einen Blutdruckwert als ein Absolutwert umgewandelt werden kann, wobei der Pulswellenbereich durch Integrieren einer Wellenform der photoelektrischen Volumenpulswelle pro Herzschlag erhalten ist;

35
die Betriebseinheit (10) den Pulswellenbereich auf der Basis der photoelektrischen Volumenpulswelle berechnet, die von dem Subjekt (5) erhalten ist, und weiters einen Blutdruckwert eines Subjekts (5) auf der Basis des berechneten Pulswellenbereichs und der Blutdruckumwandlungsdaten berechnet, **dadurch gekennzeichnet,**

40
daß die Blutdruckumwandlungsdaten auf der Basis einer Messung eines künstlichen menschlichen Körpermodells (40) berechnet sind bzw. werden, beinhaltend eine Flüssigkeitszufuhreinheit (43), die Blut oder ein Äquivalents (49) davon pro Herzschlagzeit unter Druck zuführt, die erhalten ist, während ein Probenobjekt, das eine vorbestimmte Form aufweist, in einem Ruhezustand ist, wobei die Flüssigkeitszufuhreinheit (43) einen in der Druckzufuhr einstellbaren Druck aufweist, ein Übertragungsrohr (42), durch welches das Blut oder Äquivalent davon transferiert ist bzw. wird, wobei das Transfer- bzw. Übertragungsrohr (42) einen Innendurchmesser im wesentlichen gleich einem Innendurchmesser eines Blutgefäßes des Probengegenstands bzw. -objekts aufweist, nahe welchem Blutdruck durch den photoelektrischen Sensor (26) gemessen ist, während sich der Gegenstand (5) in dem Ruhezustand befindet, einen Druckmeßabschnitt, der den Druck des Bluts oder Äquivalents davon in dem Übertragungsrohr mißt, und einen photoelektrischen Sensor, der Licht mit einer vorbestimmten Wellenlänge auf das Übertragungsrohr bestrahlt, um als eine photoelektrische Volumenpulswelle eine Änderung in einer Größe von transmittiertem bzw. übertragenem oder reflektiertem Licht zu detektieren, das aus dem bestrahlten Licht resultiert, und wobei der Druck, der auf das Blut oder Äquivalent davon während der Druckzufuhr aufgebracht ist, in verschiedene Werte variiert ist, und die photoelektrische Volumenpulswelle und der Druck, der auf das Blut oder Äquivalente davon während der Druckzufuhr aufgebracht sind, durch den photoelektrischen Sensor und den Druckmeßabschnitt gemessen sind, so daß der Pulswellenbereich pro Herzschlagzeit und der Druckwert des Bluts oder des Äquivalents (49) davon, welche beide durch den photoelektrischen Sensor (26) und den Druckmeßabschnitt erhalten sind, jeweils miteinander korreliert sind.

2. Vorrichtung nach Anspruch 1, **dadurch gekennzeichnet, daß** das Meßmodell (40) einen Strömungs- bzw. Flußraten-Meßabschnitt aufweist, der eine Flußgeschwindigkeit bzw. -rate des Bluts oder des Äquivalents (49) davon pro Herzschlagzeit mißt, der Speicherbereich (13) Flußgeschwindigkeits-Umwandlungsdaten speichert, in welchen ein Flußgeschwindigkeitswert, der durch ein Dividieren einer Flußgeschwindigkeit, die durch den Flußraten-Meßabschnitt gemessen ist, durch eine Querschnittsfläche des Übertragungsrohrs (42) erhalten ist, und der Pulswellenbereich der photoelektrischen Volumenpulswelle, die relativ zu dem Übertragungsrohr (42) gemessen ist, die Flußgeschwindigkeit und der Pulswellenbereich miteinander korreliert sind, die Meßeinheit (26) einen Pulswellenbereich So auf der Basis einer photoelektrischen Volumenpulswelle berechnet, die von dem Subjekt erhalten ist, welches sich in einem Bezugszustand vor einem Start einer Messung befindet, wobei die Meßeinheit (26) weiters einen Bezugsdruckwert Po und einen Bezugsflußgeschwindigkeitswert Vo auf der Basis des erhaltenen Pulswellenbereichs So, Blutdruckumwandlungsdaten, Flußgeschwindigkeits-Umwandlungsdaten berechnet, wobei das Meßmodell (40) weiters aus einem Algorithmus, eine Blutdruckvariationsgröße ΔP berechnet, die für eine Änderung bzw. Variation in einem Blutdruck in einer vorbestimmten Zeit nach einer Berechnung des Bezugsdruckwerts Po und des Bezugsflußgeschwindigkeitswerts Vo auf der Basis einer Änderungsrate in einem Spitzenwert der photoelektrischen Volumenpulswelle und der Referenzflußgeschwindigkeitswert Vo zu der Referenzzeit anzeigend ist, wobei der Algorithmus so bestimmt ist, daß eine Flußgeschwindigkeit Vt zu jedem Zeitpunkt durch ein Substituieren des Flußgeschwindigkeitswerts Vo berechnet ist, ein Spitzenwert Do der photoelektrischen Volumenpulswelle, ein Spitzenwert Dt der photoelektrischen Volumenpulswelle zu jeder Zeit und eine Konstanten k in eine Gleichung (a) substituiert sind und die Blutdrucksänderungsgröße ΔP durch Substituieren des Bezugsflußgeschwindigkeitswerts Vo zu der Bezugszeit, einer Flußgeschwindigkeit Vt zu jeder Zeit und einer Blutdicke p in Gleichung (b) erhalten ist:

$$V_t = (D_o/kDt)^2 \times V_o \quad (a)$$

$$P_t - P_o = \rho/2(V_o^2 - V_t^2) \quad (b)$$

3. Vorrichtung zur Beobachtung biologischer Daten nach einem der vorhergehenden Ansprüche, **dadurch gekennzeichnet, daß** eine Mehrzahl von Übertragungsrohren (42) zur Verfügung gestellt sind; die unterschiedliche Durchmesser entsprechend Unterschieden in individuellen bzw. einzelnen Subjekten (5) aufweisen, wobei die Blutdruckumwandlungsdaten und die Flußgeschwindigkeits-Umwandlungsdaten für jedes Übertragungsrohr berechnet sind;

der Speicherbereich (13) eine Mehrzahl von Datentabellen so speichert, daß die Blutdruckumwandlungsdaten und die Flußgeschwindigkeits-Umwandlungsdaten in bezug auf die Übertragungsrohre (42) mit den unterschiedlichen Durchmessern jeweils in die Datentabellen geschrieben sind;

die Meßeinheit (26) einen Blutgefäßdurchmesser-Meßabschnitt beinhaltet, der einen Durchmesser eines Blutgefäßes des Subjekts (5) in einem Ruhezustand zusätzlich zu dem photoelektrischen Sensor (26) mißt; und basierend auf Meßergebnissen durch den Blutgefäßdurchmesser-Meßabschnitt die Betriebseinheit (10) die Datentabelle wählt, die die Blutdruckumwandlungsdaten und die Flußgeschwindigkeits-Umwandlungsdaten in bezug auf das Übertragungsrohr (42) mit dem Durchmesser ungefähr gleich dem gemessenen Durchmesser des Blutgefäßes des Subjekts (5) auswählt.

4. Vorrichtung zur Beobachtung biologischer Daten nach einem der vorhergehenden Ansprüche, **dadurch gekennzeichnet, daß:**

die Meßeinheit (26) weiters einen weiteren photoelektrischen Sensor (96), beinhaltend ein einziges Licht emittierendes Element (97), und eine Mehrzahl von Licht detektierenden Elementen (98A, 98B, 98C) aufweist, welche entlang des Blutgefäßes des Subjekts (5) so angeordnet sind, daß sie voneinander beabstandet sind; die Betriebseinheit (10) einen Pulswellenbereich So auf der Basis einer photoelektrischen Volumenpulswelle berechnet, die von dem Subjekt (5) erhalten ist, welches sich temporär unter dem Meßbezugszustand vor einer Messung befindet, weiters einen Blutdruckwert Po auf der Basis des berechneten Pulswellenbereichs So und den Blutdruckumwandlungsdaten berechnet, und noch weiters eine Strömungs- bzw. Flußgeschwindigkeit Vo in dem Meßbezugszustand auf der Basis einer Phasendifferenz zwischen den photoelektrischen Volumenpulswellen, die von Licht detektierenden Elementen erhalten sind, und Abständen zwischen den Licht detektierenden Elementen berechnet;

die Betriebseinheit (10) eine Flußgeschwindigkeit Vt in jedem Zeitpunkt auf der Basis einer Phasendifferenz

EP 1 317 902 B1

zwischen den photoelektrischen Volumenpulswellen, die von den Licht detektierenden Elementen (98A, 98B, 98C) erhalten sind, und Abständen zwischen den Licht detektierenden Elementen (98A, 98B, 98C) berechnet und die Flußgeschwindigkeitswerte V_0 und V_t und die Blutdichte p für diese in der Gleichung (b) substituiert, um **dadurch** eine Blutdruckabweichungsgröße ΔP zu berechnen, die Variationen in dem Blutdruck zu jedem Zeitpunkt repräsentativ ist:

$$\Delta P = P_t - P_0 = \rho/2(V_0^2 - V_t^2) \quad (b)$$

und den Blutdruckwert P_t zu jedem Zeitpunkt bzw. in jeder Periode aus der berechneten Blutdruckvariationsgröße ΔP und dem Blutdruckwert P_0 zur Meßbezugszeit berechnet.

5. Vorrichtung zur Beobachtung biologischer Daten nach einem der vorhergehenden Ansprüche, **dadurch gekennzeichnet, daß:**

die Meßeinheit (26) weiters einen Schweißmengenmeßabschnitt, der eine Menge an Schweiß mißt, die durch das Subjekt (5) abgegeben ist, und einen Hauttemperaturmeßabschnitt beinhaltet, der eine Temperatur einer Haut des Subjekts bzw. der Person mißt;

die Betriebseinheit (10) einen Pulswellenbereich auf der Basis der photoelektrischen Volumenpulswelle des Subjekts (5) berechnet, wenn die photoelektrische Volumenpulswelle des Subjekts (5) dazu zugeführt wird, wobei weiters eine Größe bzw. Menge von Blut, das in dem Subjekt (5) strömt bzw. fließt, auf der Basis des berechneten Pulswellenbereichs und der Flußgeschwindigkeits-Umwandlungsdaten berechnet wird, und weiters Schweißmengen-Umwandlungsdaten, die die Menge an fließendem Blut und die Schweißmenge miteinander aus der berechneten Menge von fließendem Blut und der Schweißmenge korrelieren, die durch den Schweißmengenmeßabschnitt gemessen ist, und Hauttemperatur-Umwandlungsdaten berechnet, die die Menge an fließendem Blut und die Hauttemperatur miteinander auf der Basis der berechneten Menge an fließendem Blut und der Hauttemperatur korrelieren, die durch den Schweißmengenmeßabschnitt gemessen ist, wobei die Schweißmengen-Umwandlung und die Hauttemperatur-Umwandlungsdaten für jedes Subjekt (5) berechnet sind; und

die Betriebseinheit (10) Mittelwerte der Schweißmenge und der Hauttemperatur von jedem Subjekt (5) auf der Basis der Schweißmenge der Hauttemperatur-Umwandlungsdaten und der Größe bzw. Menge von Blut des Subjekts (5) berechnet, ohne die Schweißmengen- und Hauttemperatur-Meßabschnitte zu verwenden, nachdem die Schweißmenge und die Hauttemperaturdaten in den Speicherbereich (13) geschrieben wurden.

6. Vorrichtung zur Beobachtung biologischer Daten nach einem der vorhergehenden Ansprüche, **dadurch gekennzeichnet, daß:**

der Speicherbereich mit dem Körperoberflächenbereichs-Umwandlungsdaten beschrieben ist, welche persönliche bzw. Personenformdaten, beinhaltend Daten der Personengröße, Gewicht, Alter, Geschlecht und dgl. und Daten eines Körperoberflächenbereichs miteinander korrelieren, so daß ein Körperoberflächenbereich des Subjekts (5) berechnet ist; und

wenn wenigstens ein Stück von Persönlichkeitsformdaten betreffend das Subjekt (5) zu der Betriebseinheit (10) zugeführt wurden, die Betriebseinheit (10) einen Körperoberflächenbereich des Subjekts (5) auf der Basis der zugeführten Personenformdaten und der Körperoberflächenbereich-Umwandlungsdaten berechnet, wobei die Betriebseinheit (10) weiters einen Kalorienverbrauch, der von dem Subjekt (5) gefordert ist, auf der Basis des berechneten Körperoberflächenbereichs oder der Hauttemperatur und eines Mittelwerts davon berechnet.

7. Vorrichtung zur Beobachtung biologischer Daten nach einem der vorhergehenden Ansprüche, **dadurch gekennzeichnet, daß:**

der Speicherbereich (13) einen Wellenformdaten-Speicherabschnitt beinhaltet, der Wellenformdaten der zugeführten photoelektrischen Volumenpulswelle speichert;

die Betriebseinheit (10) einen erlaubten Bereich, den die Wellenformdaten normalerweise einnehmen, basierend auf den Wellenformdaten festlegt, die in dem Wellenformdaten-Speicherabschnitt akkumuliert sind; die Betriebseinheit bestimmt, ob sich neue Wellenformdaten innerhalb des erlaubten Bereichs befinden, nach

Zufuhr der Wellenformdaten dazu; und

wenn ein Teil der Wellenformdaten außerhalb des erlaubten Bereichs liegt, die Betriebseinheit (10) ein Substitutionsverfahren ausführt, in welchem jegliche Wellenformdaten für das Teil der Wellenformdaten substituiert sind bzw. werden, wobei die jeweiligen Wellenformdaten gemessen sind, bis die Wellenformdaten außerhalb des erlaubten Bereichs von dem Beginn der Messung detektiert wurden und innerhalb des erlaubten Bereichs fallend bestimmt wurden.

8. Vorrichtung zur Beobachtung biologischer Daten nach Anspruch 7, **dadurch gekennzeichnet, daß** die Betriebseinheit (10) den erlaubten Bereich auf der Basis einer Periode von vergangenen Wellenformdaten berechnet, die auf den Wellenformdaten-Speicherabschnitt geschrieben wurden.

9. Vorrichtung zur Beobachtung biologischer Daten nach Anspruch 7 oder 8, **dadurch gekennzeichnet, daß** in dem Substitutionsverfahren die Betriebseinheit (10) ein mittleres Wellenformmodell auf der Basis der Perioden und Spitzenwerte der Wellenformdaten berechnet, die gemessen sind, bis die Wellenformdaten außerhalb des erlaubten Bereichs vom Beginn einer Messung detektiert wurden und als innerhalb des erlaubten Bereichs fallend bestimmt wurden.

10. Vorrichtung zur Beobachtung biologischer Daten nach einem der vorhergehenden Ansprüche, **dadurch gekennzeichnet, daß:**

die Meßeinheit (26) einen Körperbewegungssensor umfaßt, der Licht bestrahlt, das eine Wellenlänge kürzer als eine Wellenlänge des Lichts aufweist, das durch den photoelektrischen Sensor (26) bestrahlt ist, um kontinuierlich eine Lichtmenge zu detektieren, die auf der Hautoberfläche des Subjekts (5) reflektiert ist; und die Betriebseinheit (10) ein Modifikationsverfahren ausführt, in welchem eine Ausgabewellenform des Körperbewegungssensors von einer Ausgabewellenform des photoelektrischen Sensors (26) abgezogen ist, damit ein Meßfehler aufgrund einer Körperbewegung des Subjekts (5) eliminiert werden kann.

11. Vorrichtung zur Beobachtung biologischer Daten nach einem der vorhergehenden Ansprüche, **dadurch gekennzeichnet, daß** zusätzlich zu dem photoelektrischen Sensor (26) die Meßeinheit (26) wenigstens einen umfaßt aus:

einem Schweißmengenmeßabschnitt (70), der eine Schweißmenge mißt, die durch das Subjekt (5) abgegeben ist;
einen Hauttemperaturmeßabschnitt (60), der eine Temperatur einer Haut des Subjekts (5) mißt;
einen arteriellen Sauerstoffsättigungs-Meßabschnitt, der eine arterielle Sauerstoffsättigung des Subjekts (5) mißt;
einen Herzschlagmeßabschnitt (80), der einen Herzschlag des Subjekts mißt; und
einen Hirnwellenmeßabschnitt (90), der eine Hirnwelle des Subjekts mißt; und
weilers **dadurch, daß:**

die Betriebseinheit (10) eine anästhetische Tiefe des Subjekts auf der Basis von primären, biologischen Daten berechnet, die durch den photoelektrischen Sensor (26) und den wenigstens einen aus den gewählten Meßabschnitten gemessen sind.

12. Vorrichtung zur Beobachtung biologischer Daten nach einem der vorhergehenden Ansprüche, **dadurch gekennzeichnet, daß:**

der Speicherbereich (13) Daten eines Algorithmus speichert, der unterschiedliche Stücke von primären, biologischen Daten synthetisiert, so daß ein temporärer Übergang erhalten ist, und die Betriebseinheit (10) eine Mehrzahl von Stücken von primären, biologischen Daten, die durch die Meßeinheit (26) erhalten sind, auf der Basis des Algorithmus synthetisiert, wodurch zusammengesetzte Daten A berechnet sind bzw. werden, die die Betriebseinheit (10) weiters als einen Bezugswert R_0 einen Wert zu einem Zeitpunkt unmittelbar vor oder unmittelbar nach einer Anwendung einer Anästhesie von den berechneten zusammengesetzten Daten A auswählt und einen Wert A_t der zusammengesetzten Daten A zu einem Zeitpunkt nach einer Auswahl des Bezugswerts A_0 vergleicht, wodurch eine anästhetische Tiefe berechnet ist.

13. Vorrichtung zur Beobachtung biologischer Daten nach einem der vorhergehenden Ansprüche, **dadurch gekennzeichnet, daß:**

der Speicherbereich Daten von Änderungsmustern der zusammengesetzten Daten A speichert; wenn eine Messung von primären, biologischen Daten des Subjekts (5) nach einem Zeitpunkt gestartet ist bzw. wird, wenn der Bezugswert A_0 auszuwählen ist, die Betriebseinheit (10) eines Änderungsmusters von zusammengesetzten Daten B basierend auf den biologischen Daten mit einem Änderungsmuster von vergan-
 5
 10
 15
 20
 25
 30
 35
 40
 45
 50
 55
 60
 65
 70
 75
 80
 85
 90
 95
 100
 105
 110
 115
 120
 125
 130
 135
 140
 145
 150
 155
 160
 165
 170
 175
 180
 185
 190
 195
 200
 205
 210
 215
 220
 225
 230
 235
 240
 245
 250
 255
 260
 265
 270
 275
 280
 285
 290
 295
 300
 305
 310
 315
 320
 325
 330
 335
 340
 345
 350
 355
 360
 365
 370
 375
 380
 385
 390
 395
 400
 405
 410
 415
 420
 425
 430
 435
 440
 445
 450
 455
 460
 465
 470
 475
 480
 485
 490
 495
 500
 505
 510
 515
 520
 525
 530
 535
 540
 545
 550
 555
 560
 565
 570
 575
 580
 585
 590
 595
 600
 605
 610
 615
 620
 625
 630
 635
 640
 645
 650
 655
 660
 665
 670
 675
 680
 685
 690
 695
 700
 705
 710
 715
 720
 725
 730
 735
 740
 745
 750
 755
 760
 765
 770
 775
 780
 785
 790
 795
 800
 805
 810
 815
 820
 825
 830
 835
 840
 845
 850
 855
 860
 865
 870
 875
 880
 885
 890
 895
 900
 905
 910
 915
 920
 925
 930
 935
 940
 945
 950
 955
 960
 965
 970
 975
 980
 985
 990
 995

14. Vorrichtung zur Beobachtung biologischer Daten nach einem der vorhergehenden Ansprüche, **dadurch gekennzeichnet, daß:**

die Meßeinheit (26) den photoelektrischen Sensor (26) und den Schweißmengenmeßabschnitt (70) beinhaltet; und
 die Betriebseinheit (10) Spitzenwertdaten y_1 der photoelektrischen Volumenpulswelle, die von dem photoelektrischen Sensor (26) erhalten sind, Herzschlagdaten y_5 und Schweißmengendaten y_2 aufnimmt, die von dem Schweißmengenmeßabschnitt (70) erhalten sind, um **dadurch** einen Mittelwert y_{1o} der Spitzenwertdaten in einem vorbestimmten Zeitraum vor einem Anwenden einer Anästhesie, einen Mittelwert y_{5o} der Herzschlagdaten y_5 in dem vorbestimmten Zeitraum und einen Mittelwert y_{2o} der Schweißmengendaten y_2 in dem vorbestimmten Zeitraum zu berechnen, wobei die Betriebseinheit (10) weiters eine anästhetische Tiefe T_1 einer Pulswelle und eine anästhetische Tiefe T_2 einer Schweißmenge aus den folgenden Gleichungen (13) und (14) jeweils auf der Basis der Mittelwerte y_{1o} , y_{5o} und y_{2o} und eines Werts y_{1t} der Spitzenwertdaten y_1 in einem vorbestimmten Zeitraum nach einem Anwenden einer Anästhesie, eines Werts y_{5t} der Herzschlagdaten y_5 in dem vorbestimmten Zeitraum und eines Werts y_{2t} der Schweißmengendaten y_2 erhält, wobei weiters eine anästhetische Tiefe T ($T=T_1+T_2$) auf der Basis der erhaltenen anästhetischen Tiefe T_1 der Pulswelle und der anästhetischen Tiefe T_2 der Schweißmenge berechnet wird:

$$T_1 = (y_{1t} - k_1 y_{1o} - k_2 y_{5o}) / (k_3 y_{1o} - k_4 y_{5o}) \quad (13)$$

$$T_2 = (y_{2t} - k_5 y_{2o}) / (k_6 y_{2o}) \quad (14)$$

wobei k_1 , k_2 und k_3 Konstante sind.

15. Vorrichtung zur Beobachtung biologischer Daten nach einem der vorhergehenden Ansprüche, **dadurch gekennzeichnet, daß** die Betriebseinheit (10) eine Herzschlagdaten und eine arterielle Sauerstoffsättigung auf der Basis der photoelektrischen Volumenpulswelle, die durch den photoelektrischen Sensor erhalten ist, und Blutdruckumwandlungsdaten berechnet.

16. Vorrichtung zur Beobachtung biologischer Daten nach einem der vorhergehenden Ansprüche, **dadurch gekennzeichnet, daß:**

ein Speicherbereich (13) Blutdruck- und Blutflußumwandlungsdaten speichert, in welchen der Blutdruck und die Menge an Blutstrom miteinander korreliert sind; und
 der Betätigungsabschnitt (10) eine Blutflußmenge des Subjekts (5) aus einem Blutdruckwert des Subjekts (5) und den Blutdruck- und Blutflußumwandlungsdaten berechnet.

Revendications

1. Appareil d'observation de données biologiques, qui comprend :

une unité de mesure qui comprend au moins un détecteur photoélectrique (26) qui comprend un élément d'émission de lumière (26A) qui émet de la lumière d'une longueur d'onde prédéterminée sur un vaisseau sanguin d'un sujet (5) et un élément (26B) de détection de lumière qui détecte sous la forme d'une onde photoélectrique pulsée en volume une modification de la quantité de lumière émise ou réfléchi qui résulte

EP 1 317 902 B1

de la lumière émise par l'élément d'émission de lumière,
une unité de traitement (10) qui reçoit le résultat de mesure de l'unité de mesure de telle sorte que l'unité de
traitement (10) effectue une opération en fonction du résultat de mesure qui lui a été délivré,
une zone de mémoire (13) qui conserve les données des résultats de mesure ou similaires et
une unité d'affichage (30) qui affiche le résultat du calcul effectué par l'unité de traitement (10),
la zone de mémoire (13) conservant des données de conversion de pression sanguine qui établissent une
corrélacion entre une zone d'onde pulsée et une valeur de pression sanguine de telle sorte que la zone d'onde
pulsée peut être convertie en une valeur de pression sanguine sous la forme d'une valeur absolue, la zone
d'onde pulsée étant obtenue en intégrant la forme d'onde de l'onde photoélectrique pulsée en volume par
battement du coeur,
l'unité de traitement (10) calculant la zone d'onde pulsée en fonction de l'onde photoélectrique pulsée en
volume émise par le sujet (5) et calculant en outre la valeur de pression sanguine du sujet (5) en fonction de
la zone d'onde pulsée calculée et des données de conversion de pression sanguine, **caractérisé en ce que** :

les données de conversion de pression sanguine sont calculées en fonction d'un modèle de mesure de
corps humain artificiel (40) qui comprend une unité d'alimentation en liquide (43) qui délivre du sang sous
pression ou l'un de ses équivalents (49) par durée de battement du coeur obtenue pendant qu'un objet
d'échantillonnage qui présente une forme prédéterminée est à l'état de repos, la pression d'alimentation
de l'unité (43) d'alimentation en liquide pouvant être ajustée, un tube de transfert (42) par lequel le sang
ou l'un de ses équivalents sont transférés, le diamètre intérieur du tube de transfert (42) étant essentielle-
ment égal au diamètre intérieur d'un vaisseau sanguin de l'objet d'échantillonnage à proximité duquel
le détecteur photoélectrique (26) mesure la pression sanguine pendant que l'objet (5) est à l'état de repos,
une partie de mesure de pression qui mesure la pression du sang ou de l'un de ses équivalents dans le
tube de transfert et un détecteur photoélectrique qui émet de la lumière d'une longueur d'onde prédéter-
minée sur le tube de transfert pour détecter sous la forme d'une onde photoélectrique pulsée en volume
une modification de la quantité de lumière émise ou réfléchie qui résulte de la lumière émise, la pression
appliquée sur le sang ou l'un de ses équivalents pendant l'alimentation sous pression étant modifiée à
différentes valeurs, l'onde photoélectrique pulsée en volume et la pression appliquée sur le sang ou l'un
de ses équivalents pendant l'alimentation par pression étant mesurées respectivement par le détecteur
photoélectrique et par la partie de mesure de pression de telle sorte qu'une corrélation soit établie entre
la zone d'onde pulsée par durée de battement du coeur et la valeur de pression du sang ou de l'un de
ses équivalents (49) qui sont obtenues respectivement à l'aide du détecteur photoélectrique (26) et de la
partie de mesure de pression.

2. Appareil selon la revendication 1, **caractérisé en ce que** le modèle de mesure (40) comprend une partie de mesure
de débit qui mesure le débit du sang ou de l'un de ses équivalents (49) par durée de battement du coeur, **en ce
que** la zone de mémoire (13) conserve des données de conversion de débit, la valeur de débit étant obtenue en
divisant le débit mesuré par la partie de mesure de débit par la superficie de la section transversale du tube de
transfert (42), la zone d'onde pulsée de l'onde photoélectrique pulsée en volume étant mesurée par rapport au
tube de transfert (42), une corrélation étant établie entre le débit et la zone d'onde pulsée, **en ce que** l'unité de
mesure (26) calcule la zone d'onde pulsée So en fonction de l'onde photoélectrique pulsée en volume émise par
le sujet qui est à un état de référence avant le début de la mesure, l'unité de mesure (26) calculant en outre la
valeur de la pression de référence Po et la valeur du débit de référence Vo en fonction de la zone d'onde pulsée
obtenue So, des données de conversion de pression sanguine et des données de conversion de débit, le modèle
de mesure (40) calculant en outre à l'aide d'un algorithme la valeur de la modification de pression sanguine ΔP
qui indique une modification de la pression sanguine pendant une durée prédéterminée après le calcul de la valeur
de la pression de référence Po et de la valeur du débit de référence Vo en fonction du taux de modification de la
valeur de pointe de l'onde photoélectrique pulsée en volume et de la valeur du débit de référence Vo à l'instant
de référence, l'algorithme étant déterminé de telle sorte que le débit Vt à un instant quelconque est calculé en
introduisant dans l'équation (a) la valeur du débit Vo, la valeur de pointe Do de l'onde photoélectrique pulsée en
volume, la valeur de pointe Dt de l'onde photoélectrique pulsée en volume à un instant quelconque et la constante
k, la valeur de la modification de pression sanguine ΔP étant obtenue en introduisant dans l'équation (b) la valeur
du débit de référence Vo à l'instant de référence, le débit Vt à un instant quelconque et la densité ρ du sang :

$$V_t = (D_o/kDt)^2 \times V_o \quad (a)$$

$$P_t - P_o = \rho/2(V_o^2 - V_t^2) \quad (b)$$

3. Appareil d'observation de données biologiques selon l'une quelconque des revendications précédentes, **caractérisé en ce qu'**on prévoit plusieurs tubes de transfert (42) dont le diamètre diffère en fonction des différences entre des sujets individuels (5), les données de conversion de pression sanguine et les données de conversion de débit étant calculées pour chaque tube de transfert,

en ce que la zone de mémoire (13) conserve plusieurs tableaux de données de telle sorte que les données de conversion de pression sanguine et les données de conversion de débit relatives aux tubes de transfert (42) dont le diamètre diffère sont conservées dans les tableaux de données respectifs,

en ce que, en plus du détecteur photoélectrique (26), l'unité de mesure (26) comprend une partie de mesure de diamètre de vaisseau sanguin qui mesure le diamètre d'un vaisseau sanguin du sujet (5) à l'état de repos et

en ce que, en fonction des résultats de mesure de la partie de mesure de diamètre de vaisseau sanguin, l'unité de traitement (10) sélectionne le tableau de données qui conserve les données de conversion de pression sanguine et les données de conversion de débit relatives aux tubes de transfert (42) dont le diamètre approche le diamètre mesuré du vaisseau sanguin du sujet (5).

4. Appareil d'observation de données biologiques selon l'une quelconque des revendications précédentes, **caractérisé en ce que** :

l'unité de mesure (26) comprend en outre un autre détecteur photoélectrique (96) qui comprend un unique élément d'émission de lumière (97) et plusieurs éléments de détection de lumière (98A, 98B, 98C) qui sont disposés le long du vaisseau sanguin du sujet (5) de manière à être distants les uns des autres,

en ce que l'unité de traitement (10) calcule la zone d'onde pulsée S_o en fonction de l'onde photoélectrique pulsée en volume délivrée par le sujet (5) qui est temporairement à l'état de référence de mesure qui précède la mesure, calcule en outre la valeur de la pression sanguine P_o en fonction de la zone d'onde pulsée calculée S_o et des données de conversion de pression sanguine et calcule encore en outre le débit V_o à l'état de référence de mesure en fonction de la différence de phase entre les ondes photoélectriques pulsées en volume délivrées par les éléments de détection de lumière et la distance qui sépare les éléments de détection de lumière,

en ce que l'unité de traitement (10) calcule le débit V_t pendant une durée quelconque en fonction de la différence de phase entre les ondes photoélectriques pulsées en volume délivrées par les éléments de détection de lumière (98A, 98B, 98C) et la distance qui sépare les éléments de détection de lumière (98A, 98B, 98C), introduit les valeurs de débit V_o et V_t et la densité ρ du sang dans l'équation (b), ce qui permet de calculer la valeur de la modification de pression sanguine ΔP qui représente les modifications de la pression sanguine pendant une durée quelconque :

$$\Delta P = P_t - P_o = \rho/2(V_o^2 - V_t^2) \quad (b)$$

et calcule la valeur de la pression sanguine P_t pendant une durée quelconque à partir de la valeur de la modification de pression sanguine ΔP et de la valeur de pression sanguine P_o à l'instant de référence de mesure.

5. Appareil d'observation de données biologiques selon l'une quelconque des revendications précédentes, **caractérisé en ce que** :

l'unité de mesure (26) comprend en outre une partie de mesure de la quantité de sueur qui mesure la quantité de sueur rejetée par le sujet (5) et une partie de mesure de la température de la peau qui mesure la température de la peau du sujet,

en ce que l'unité de traitement (10) calcule la zone d'onde pulsée en fonction de l'onde photoélectrique pulsée en volume délivrée par le sujet (5) lorsque l'onde photoélectrique pulsée en volume du sujet (5) lui est délivrée, calcule en outre la quantité de sang qui s'écoule dans le sujet (5) en fonction de la zone d'onde pulsée calculée et des données de conversion de débit et calcule en outre des données de conversion de quantité de sueur qui établissent une corrélation entre la quantité de sang qui s'écoule et la quantité de sueur en fonction de la quantité calculée de sang qui s'écoule et de la quantité de sueur mesurée par la partie de mesure de quantité de sueur, et des données de conversion de température de peau, qui établissent une corrélation entre la

EP 1 317 902 B1

quantité de sang qui s'écoule et la température de la peau en fonction de la quantité calculée de sang qui s'écoule et la température de la peau mesurée par la partie de mesure de quantité de sueur, les données de conversion de quantité de sueur et les données de conversion de température de peau étant calculées pour chaque sujet (5), et

en ce que l'unité de traitement (10) calcule les valeurs moyennes de la quantité de sueur et de la température de la peau de chaque sujet (5) en fonction des données de conversion de quantité de sueur, des données de conversion de température de peau et de la quantité de sang du sujet (5) sans utiliser la partie de mesure de quantité de sueur ni la partie de mesure de température de peau après que les données relatives à la quantité de sueur et les données relatives à la température de la peau ont été conservées dans la zone de mémoire (13).

6. Appareil d'observation de données biologiques selon l'une quelconque des revendications précédentes, **caractérisé en ce que** :

la zone de mémoire conserve des données de conversion de superficie corporelle qui établissent une corrélation entre des données personnelles de forme, notamment des données relatives à la taille, au poids, à l'âge, au sexe d'un individu et similaires, et des données de superficie corporelle de telle sorte que la superficie corporelle du sujet (5) est calculée et

en ce que, lorsqu'au moins une partie des données personnelles de forme relatives au sujet (5) a été délivrée à l'unité de traitement (10), l'unité de traitement (10) calcule la superficie corporelle du sujet (5) en fonction des données de forme personnelles et des données de conversion de superficie corporelle qui lui ont été délivrées, l'unité de traitement (10) calculant en outre la consommation de calories dont le sujet (5) a besoin en fonction de la superficie corporelle ou de la température de la peau calculées et de leur valeur moyenne.

7. Appareil d'observation de données biologiques selon l'une quelconque des revendications précédentes, **caractérisé en ce que** :

la zone de mémoire (13) comprend une partie de conservation de données de forme d'onde qui conserve les données de forme d'onde de l'onde photoélectrique pulsée en volume qui lui a été délivrée,

en ce que l'unité de traitement (10) règle la plage permise dans laquelle les données de forme d'onde sont situées normalement en fonction des données de forme d'onde conservées dans la partie de conservation de données de forme d'onde,

en ce que l'unité de traitement détermine si de nouvelles données de forme d'onde sont dans la plage permise lorsque les données de forme d'onde lui ont été délivrées et

en ce que, lorsqu'une partie des données de forme d'onde est en dehors de la plage permise, l'unité de traitement (10) effectue une opération de remplacement qui consiste à remplacer des données de forme d'onde quelconques par ladite partie des données de forme d'onde, lesdites données de forme d'onde quelconques étant mesurées jusqu'à avoir détecté les données de forme d'onde situées en dehors de la plage permise depuis le début de la mesure et avoir déterminé qu'elles sont dans la plage permise.

8. Appareil d'observation de données biologiques selon la revendication 7, **caractérisé en ce que** l'unité de traitement (10) calcule la plage permise en fonction de la durée de données antérieures de forme d'onde conservées dans la partie de conservation de données de forme d'onde.

9. Appareil d'observation de données biologiques selon les revendications 7 ou 8, **caractérisé en ce que**, dans l'opération de remplacement, l'unité de traitement (10) calcule un modèle de forme d'onde moyenne en fonction des durées et des valeurs de pointe des données de forme d'onde mesurées jusqu'à avoir détecté les données de forme d'onde situées dans la plage permise depuis le début de la mesure et avoir déterminé qu'elles se situent dans la plage permise.

10. Appareil d'observation de données biologiques selon l'une quelconque des revendications précédentes, **caractérisé en ce que** :

l'unité de mesure (26) comprend un détecteur de déplacement corporel qui émet de la lumière dont la longueur d'onde est plus courte que la longueur d'onde de la lumière émise par le détecteur photoélectrique (26) de manière à détecter en continu la quantité de lumière réfléchie par la surface de la peau du sujet (5) et

en ce que l'unité de traitement (10) effectue une opération de modification qui consiste à soustraire la forme d'onde de sortie du détecteur de déplacement corporel de la forme d'onde de sortie du détecteur photoélectrique (26) de manière à pouvoir éliminer l'erreur de mesure due au déplacement corporel du sujet (5).

11. Appareil d'observation de données biologiques selon l'une quelconque des revendications précédentes, **caractérisé en ce qu'**en plus du détecteur photoélectrique (26), l'unité de mesure (26) comprend en outre au moins l'une quelconque parmi :

5 une partie (70) de mesure de quantité de sueur qui mesure la quantité de sueur rejetée par le sujet (5),
 une partie (60) de mesure de température de peau qui mesure la température de la peau du sujet (5),
 une partie de mesure de saturation en oxygène artériel qui mesure la saturation en oxygène artériel du sujet (5),
 une partie de mesure des battements du coeur qui mesure les battements de coeur du sujet et
 10 une partie (90) de mesure d'onde cérébrale qui mesure l'onde cérébrale du sujet (5), et en outre **en ce que** :

l'unité de traitement (10) calcule la profondeur anesthésique du sujet en fonction des données biologiques primaires mesurées par le détecteur photoélectrique (26) et par au moins l'une quelconque parmi lesdites parties de mesure sélectionnées.

15 12. Appareil d'observation de données biologiques selon l'une quelconque des revendications précédentes, **caractérisé en ce que** :

la zone de mémoire (13) conserve les données d'un algorithme qui synthétise différentes parties de données biologiques primaires de telle sorte qu'une transition temporelle est obtenue et **en ce que** l'unité de traitement (10) synthétise en fonction de l'algorithme plusieurs parties de données biologiques primaires délivrées par l'unité de mesure (26), ce qui permet de calculer des données composites A, l'unité de traitement (10) sélectionnant en outre, comme valeur de référence V_0 , la valeur à un instant situé approximativement avant ou immédiatement après l'application de l'anesthésie à partir des données composites calculées A et comparant la valeur A_t des données composites A après la sélection de la valeur de référence A_0 , ce qui permet de
 20 calculer la profondeur anesthésique.
 25

13. Appareil d'observation de données biologiques selon l'une quelconque des revendications précédentes, **caractérisé en ce que** :

la zone de mémoire (13) conserve des données de motifs de modification des données composites A, **en ce que**, lorsque la mesure des données biologiques primaires du sujet (5) commence après l'instant où la valeur de référence A_0 doit être sélectionnée, l'unité de traitement (10) rassemble le motif de modification de données composites B en fonction desdites données biologiques et le motif de modification des données composites précédentes conservées dans la zone de mémoire (13), ce qui permet d'extraire des données composites similaires R et de remplacer les données composites B par la valeur de référence R_0 des données composites R, l'unité de traitement (10) calculant en outre la profondeur anesthésique du sujet (5) en fonction de la valeur de référence remplacée R_0 et de la valeur B_t des données composites B.
 30
 35

40 14. Appareil d'observation de données biologiques selon l'une quelconque des revendications précédentes, **caractérisé en ce que** :

l'unité de mesure (26) comprend le détecteur photoélectrique (26) et la partie (70) de mesure de quantité de sueur et **en ce que** l'unité de traitement (10) incorpore les données de valeur de pointe y_1 de l'onde photoélectrique pulsée en volume qui lui ont été délivrées par le détecteur photoélectrique, les données de battement du coeur y_5 et les données de quantité de sueur y_2 qui lui ont été délivrées par la partie (70) de mesure de quantité de sueur, ce qui permet de calculer la valeur moyenne y_{10} des données de valeur de pointe pendant une durée prédéterminée avant l'application de l'anesthésie, la valeur moyenne y_{50} des données de battement du coeur y_5 pendant la durée prédéterminée et la valeur moyenne y_{20} des données de quantité de sueur y_2 pendant la durée prédéterminée, l'unité de traitement (10) obtenant en outre la profondeur anesthésique d'onde pulsée T_1 et la profondeur anesthésique de quantité de sueur T_2 à partir des équations (13) et (14) ci-dessous, respectivement en fonction des valeurs moyennes y_{10} , y_{50} et y_{20} , de la valeur y_{1t} des données de valeur de pointe y_1 pendant une durée prédéterminée après l'application de l'anesthésie, de la valeur y_{5t} des données de battements de coeur y_5 pendant la durée prédéterminée et de la valeur y_{2t} des données de quantité de sueur y_2 , et calculant en outre la profondeur anesthésique T ($T = T_1 + T_2$) en fonction de la profondeur anesthésique d'onde pulsée T_1 et de la profondeur anesthésique de quantité de sueur T_2 obtenues :
 45
 50
 55

EP 1 317 902 B1

$$T1 = (y1t \times y5t - k1 \times y1o \times y5o) / (k2 \times y1o \times y5o) \quad (13)$$

5

$$T2 = (y2t - k3 \times y2o) / (k4 \times y2o) \quad (14)$$

dans lesquelles k1, k2 et k3 sont des constantes.

- 10 **15.** Appareil d'observation de données biologiques selon l'une quelconque des revendications précédentes, **caracté-**
risé en ce que :

l'unité de traitement (10) calcule la sortie cardiaque et la saturation en oxygène artériel en fonction de l'onde photoélectrique pulsée en volume qui lui a été délivrée par le détecteur photoélectrique et des données de conversion de pression sanguine.

- 15 **16.** Appareil selon l'une quelconque des revendications précédentes, **caractérisé en ce que :**

20 une zone de mémoire (13) conserve des données de pression sanguine et des données de conversion de débit sanguin, une corrélation étant établie entre la pression sanguine et la valeur du débit sanguin, et
en ce que l'unité de traitement (10) calcule la valeur du débit sanguin du sujet (5) à partir de la valeur de pression sanguine du sujet (5), des données de pression sanguine et des données de conversion de débit sanguin.

25

30

35

40

45

50

55

Fig. 1

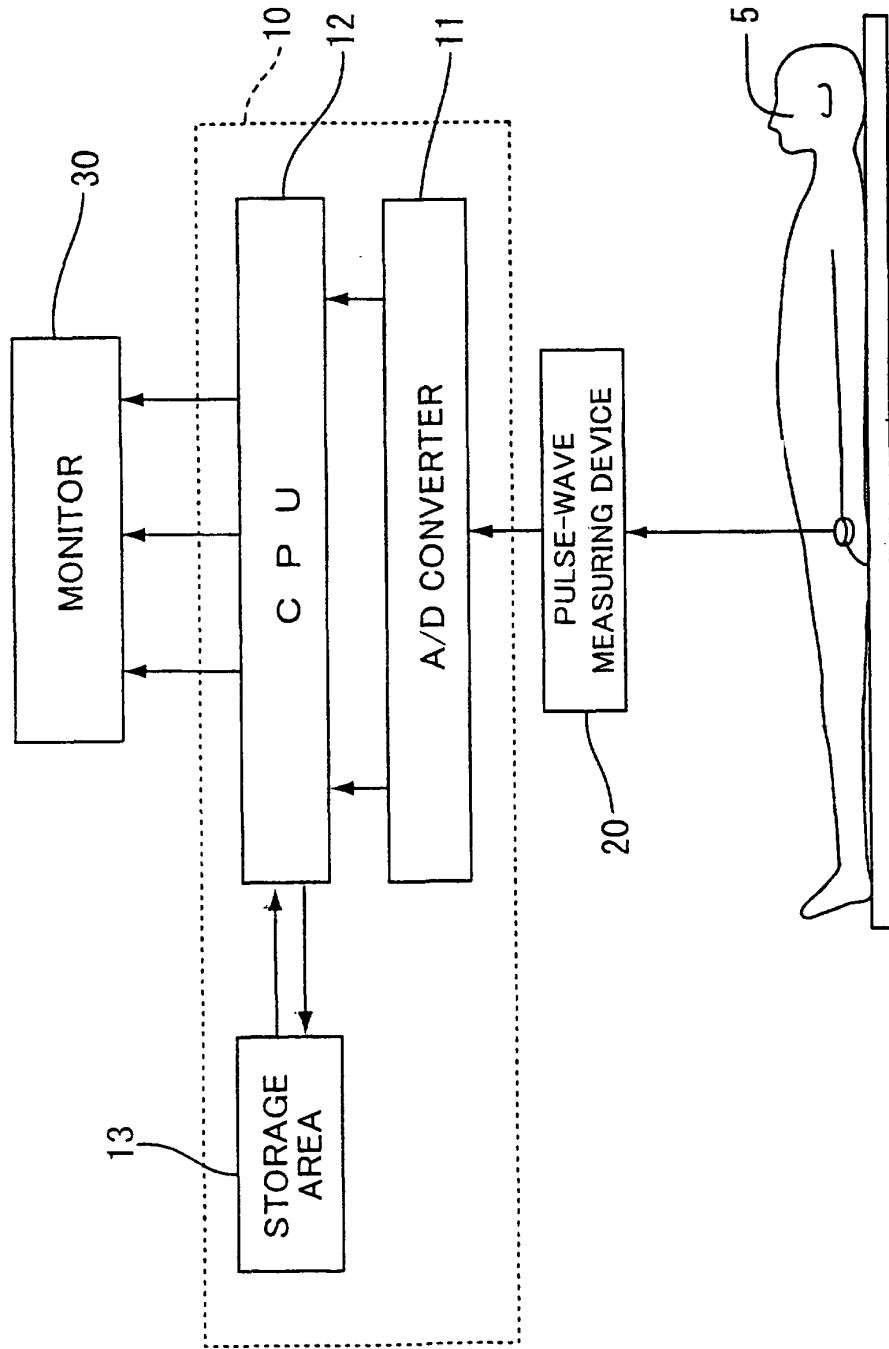

Fig. 2

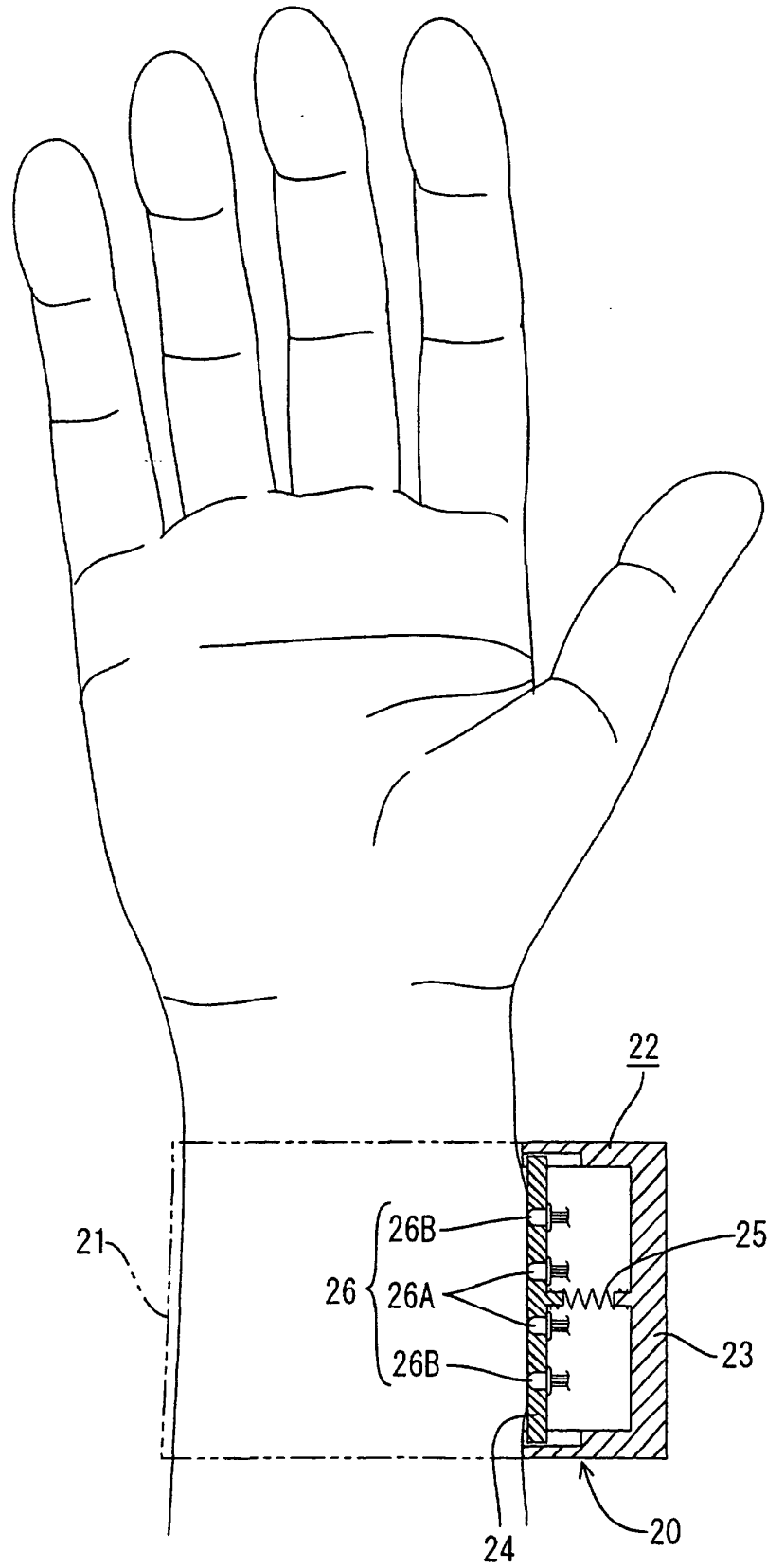

Fig. 3

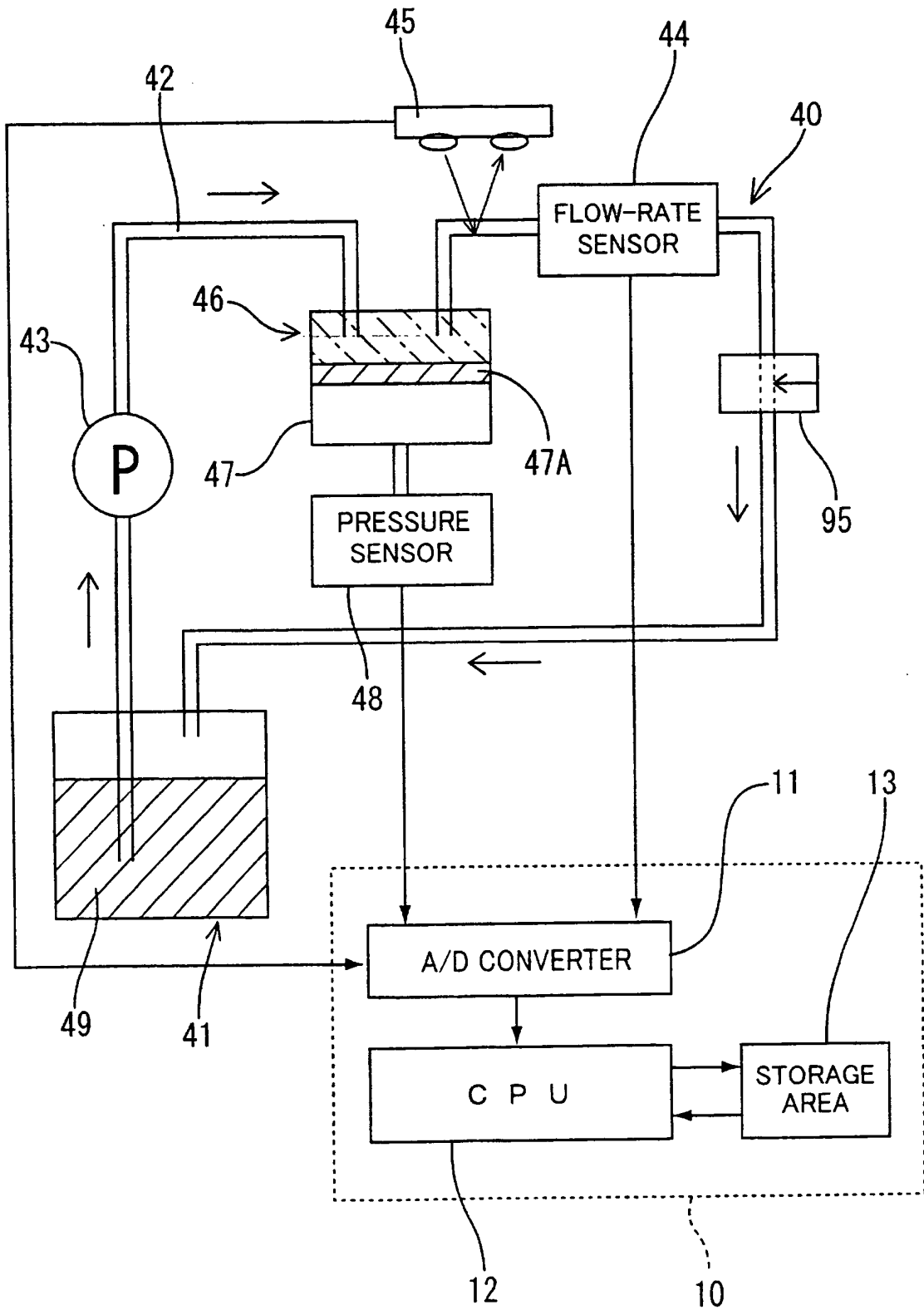

Fig. 4A

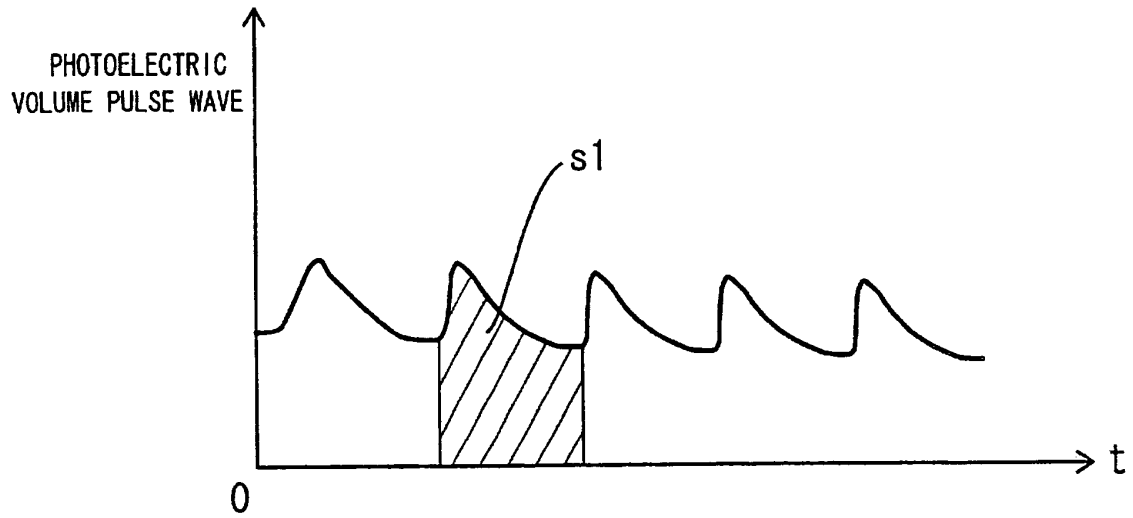

Fig. 4B

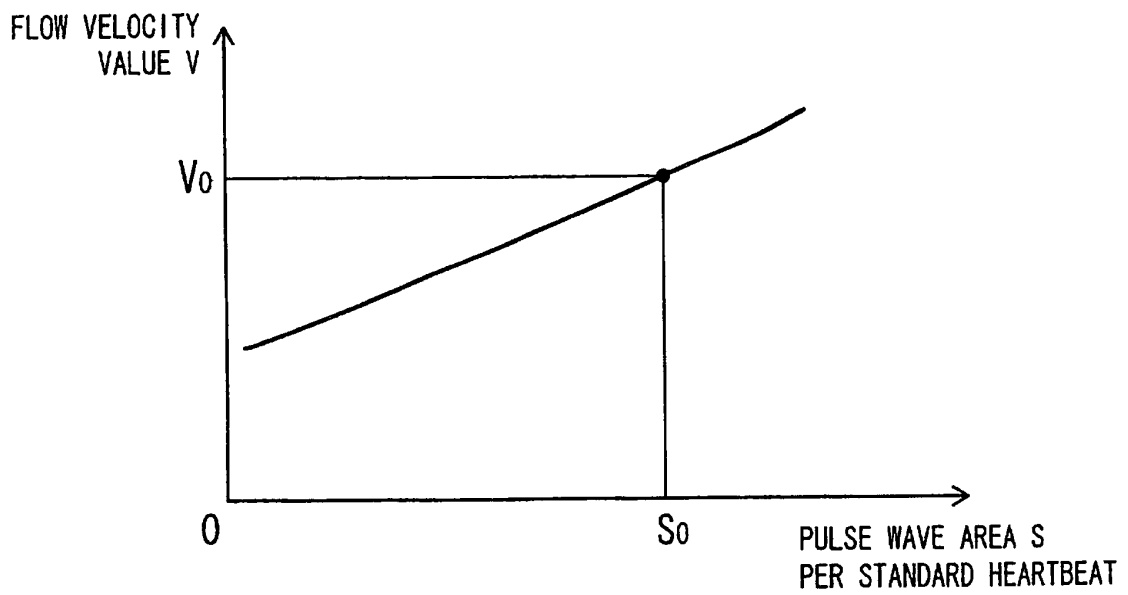

Fig. 4C

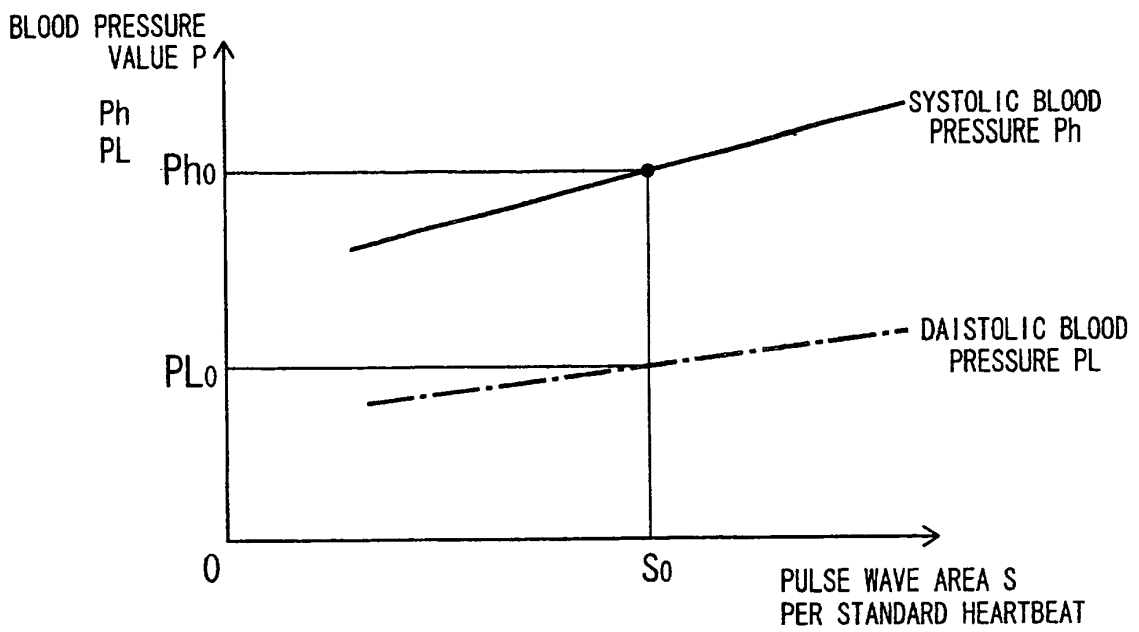

Fig. 5

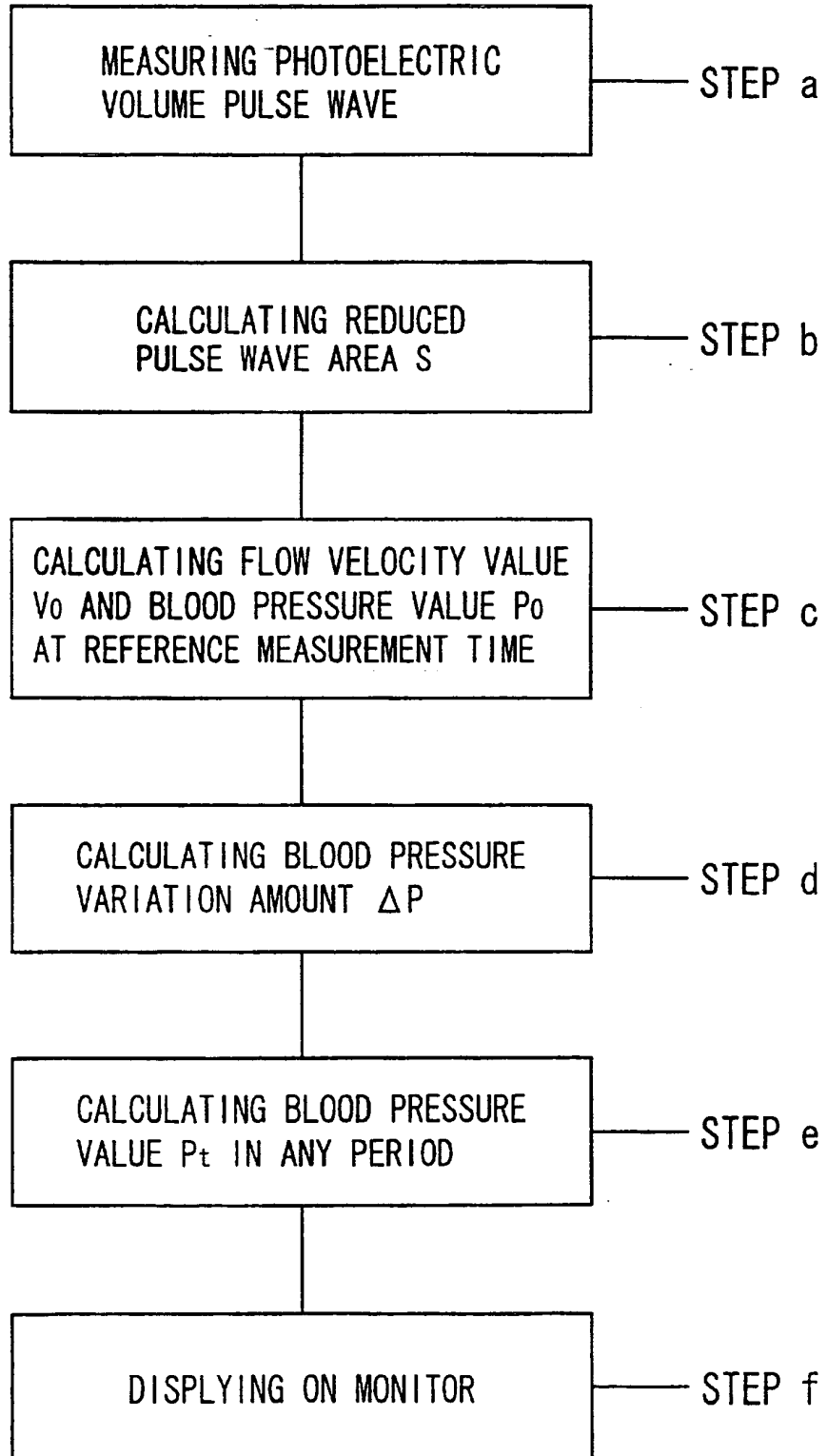

Fig. 6

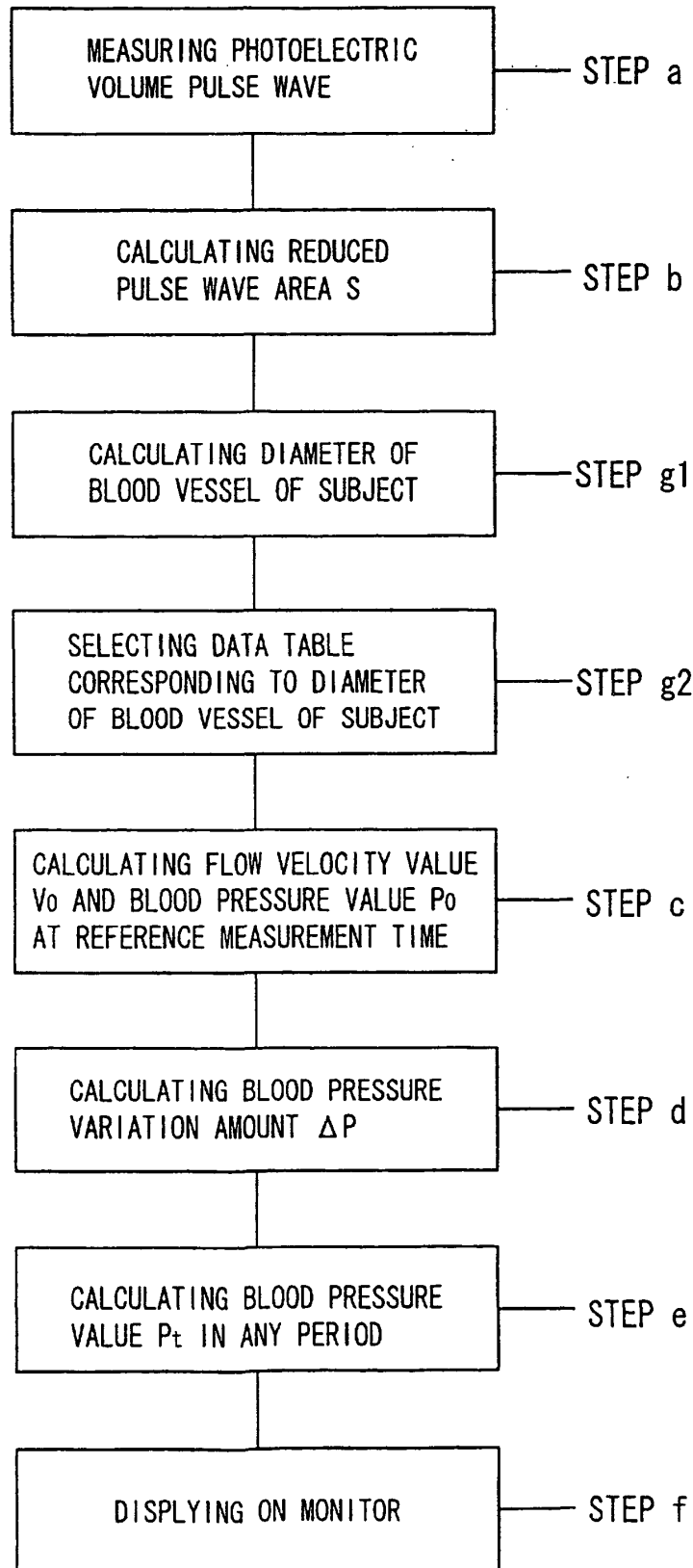

Fig. 7

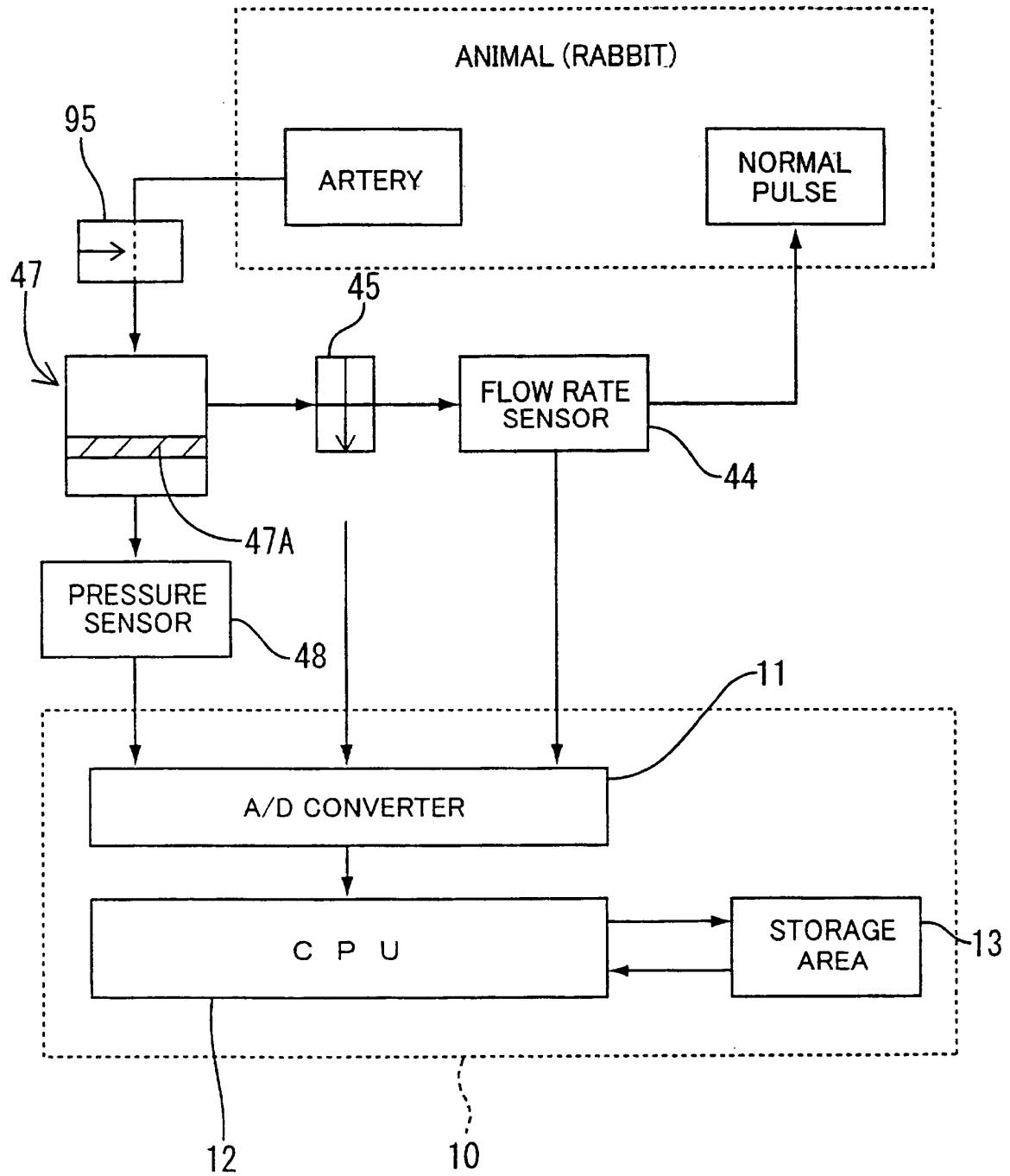

Fig. 8

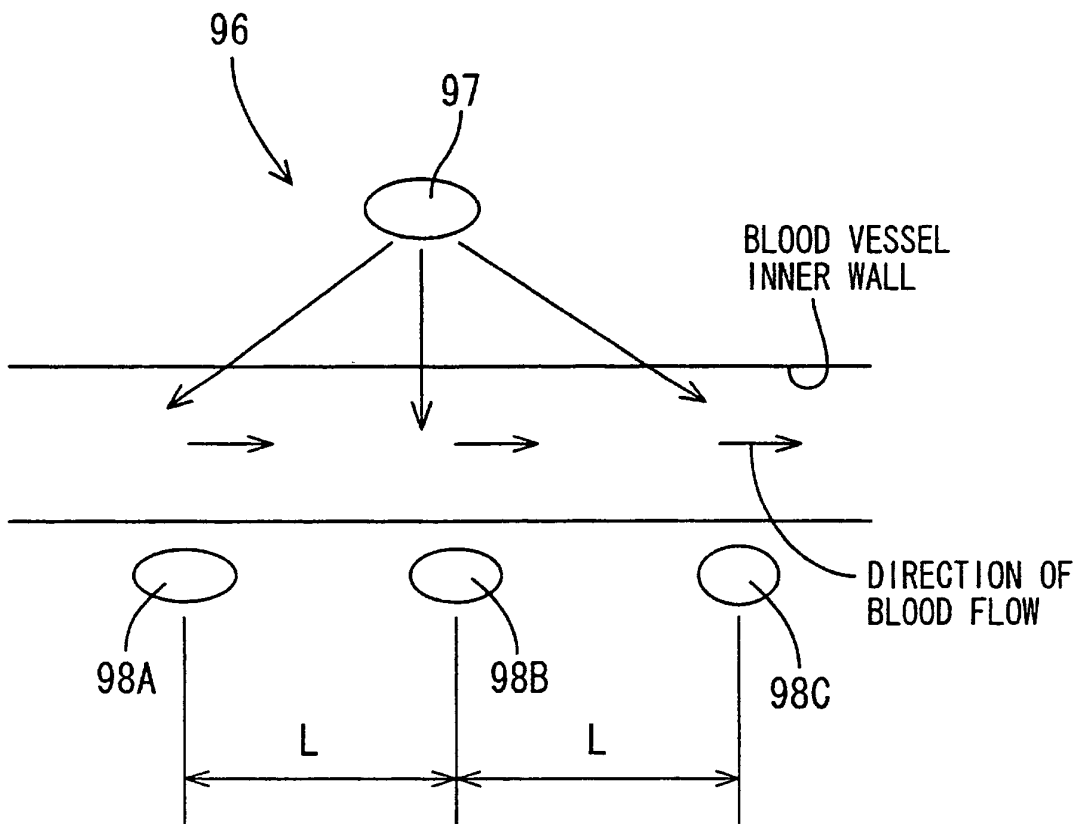

Fig. 9C

LIGHT DETECTING ELEMENT 98C

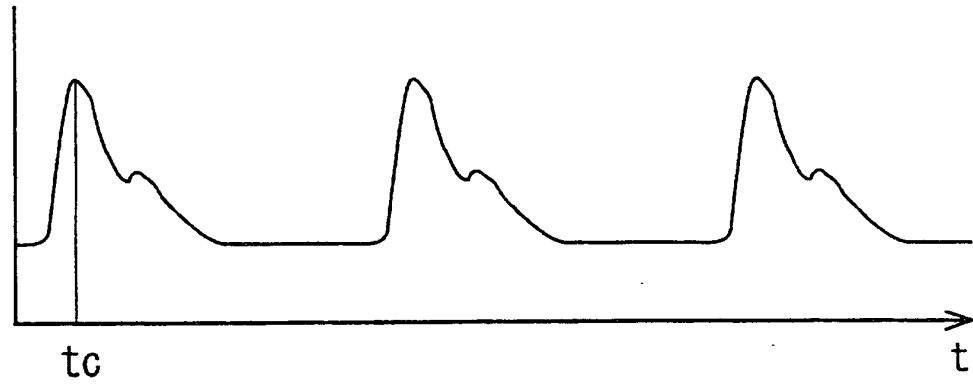

Fig. 9B

LIGHT DETECTING ELEMENT 98B

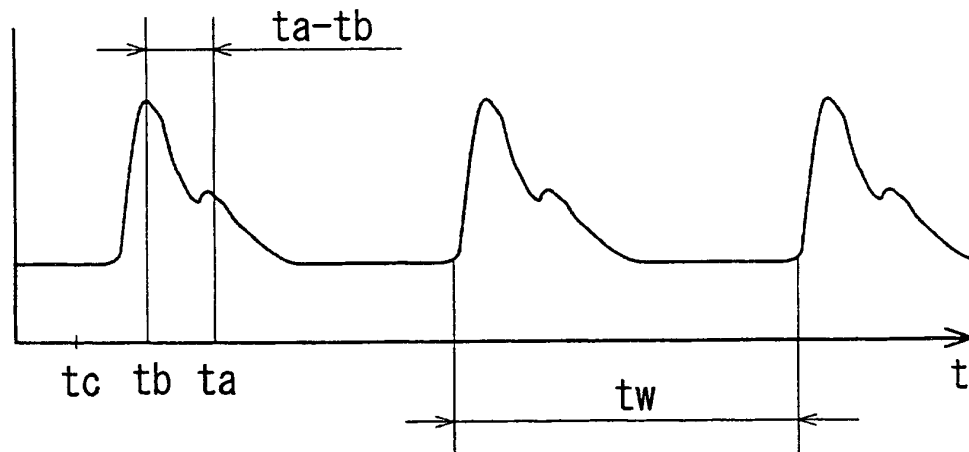

Fig. 9A

LIGHT DETECTING ELEMENT 98A

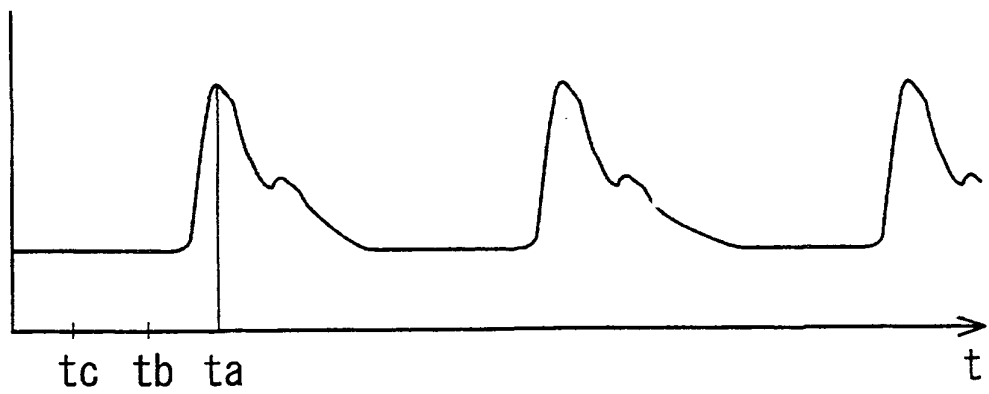

Fig. 10

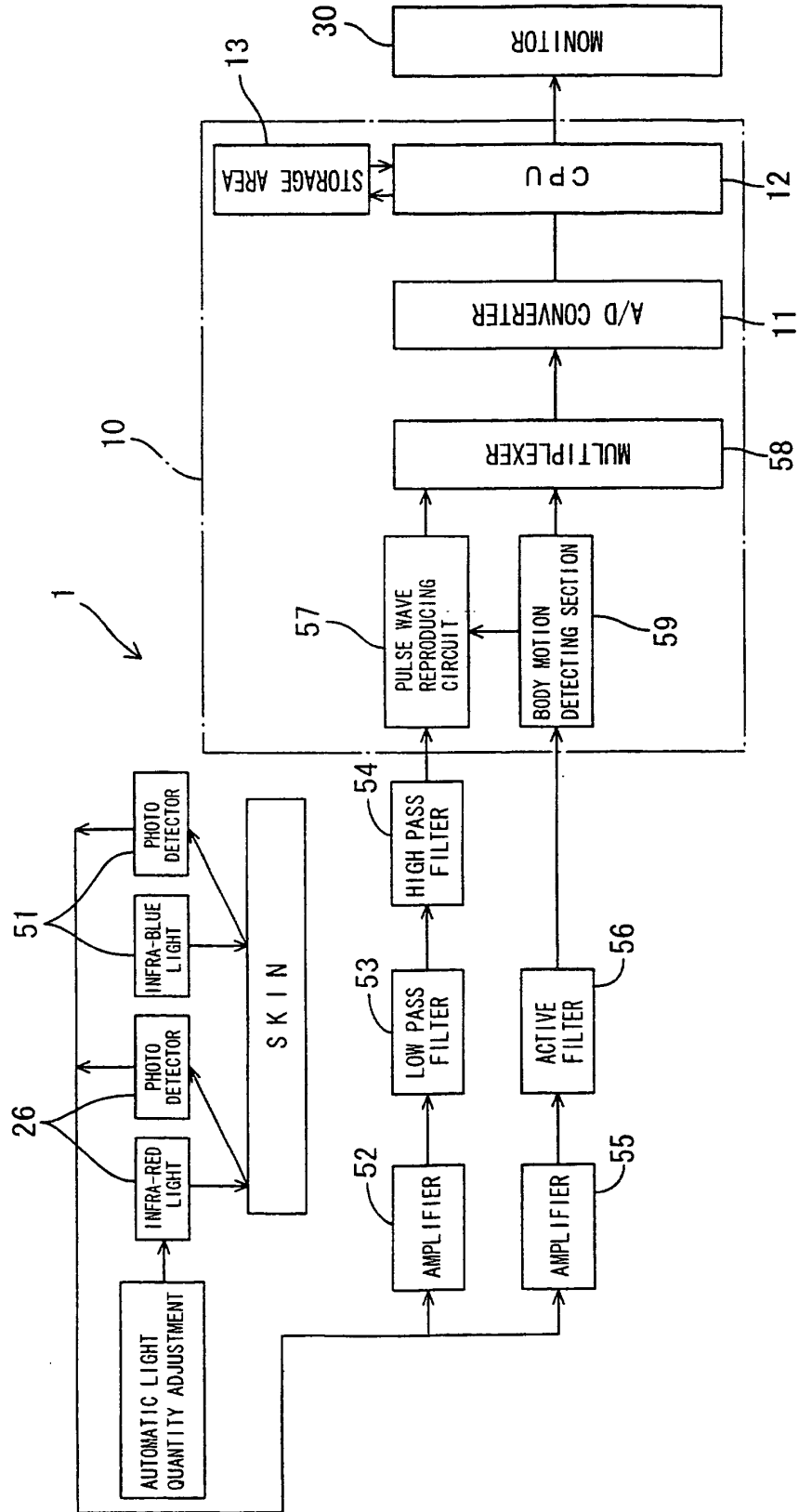

Fig. 11

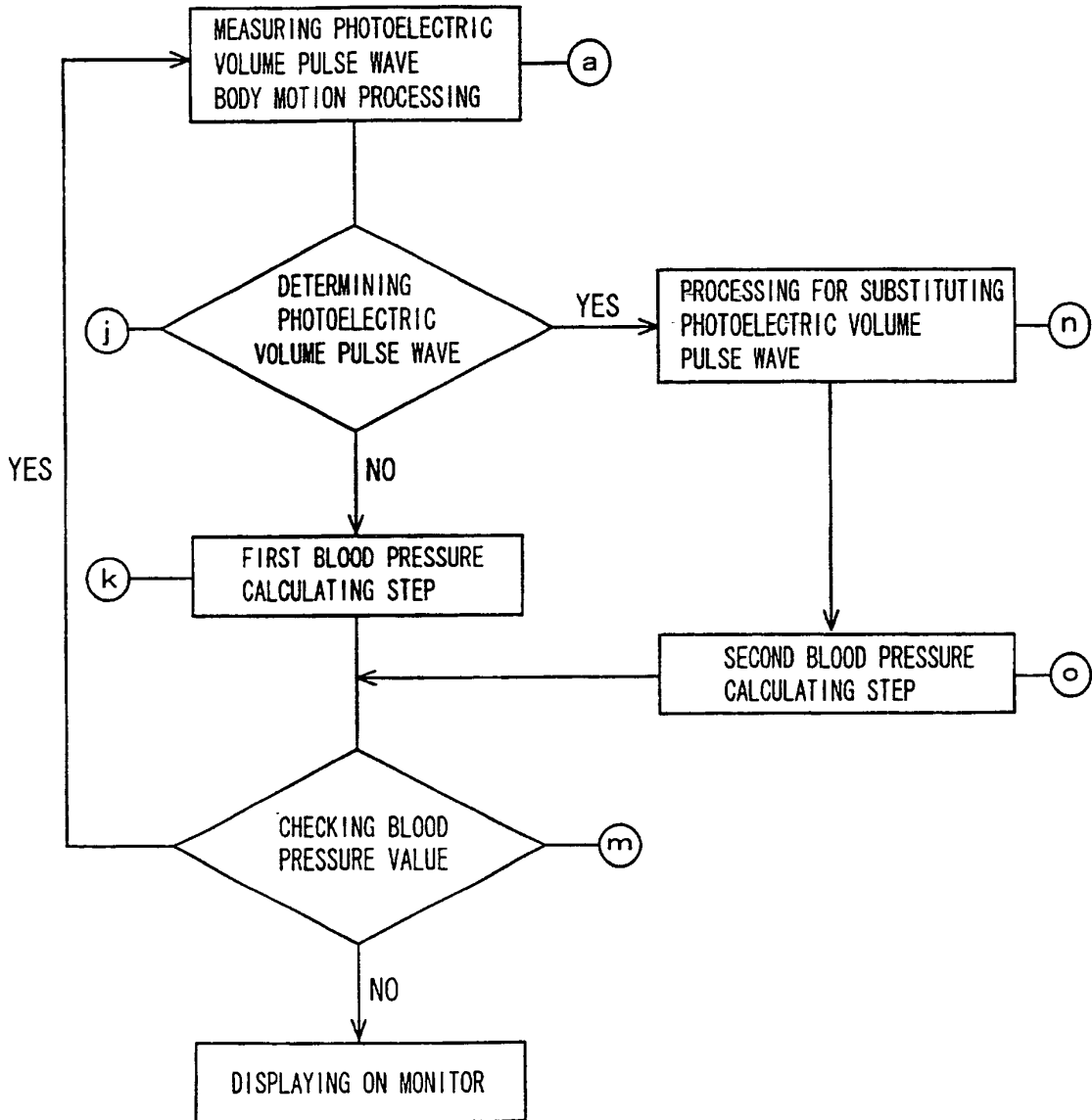

Fig. 12A

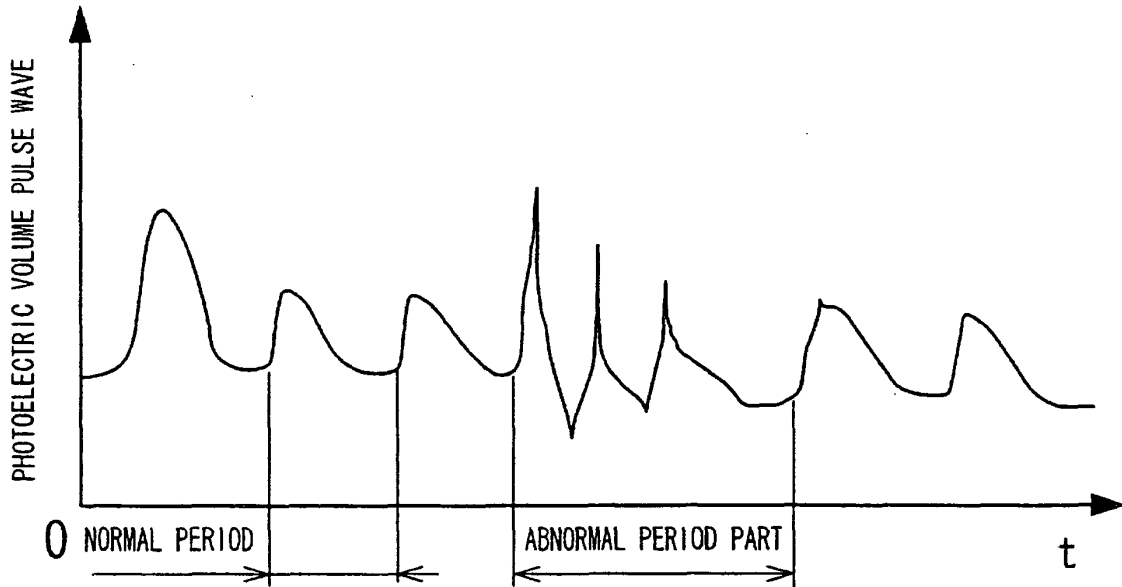

Fig. 12B

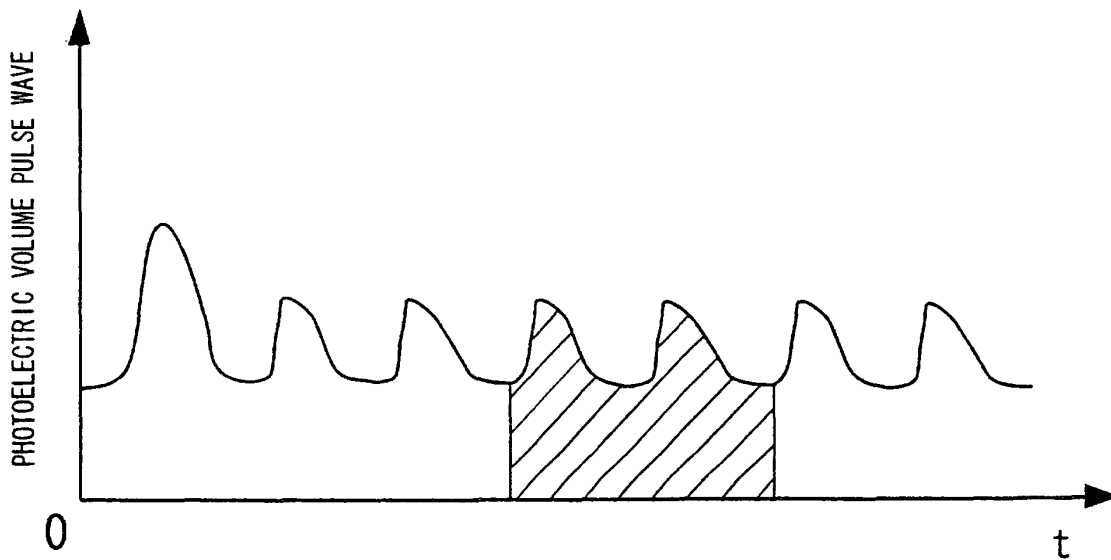

Fig. 13

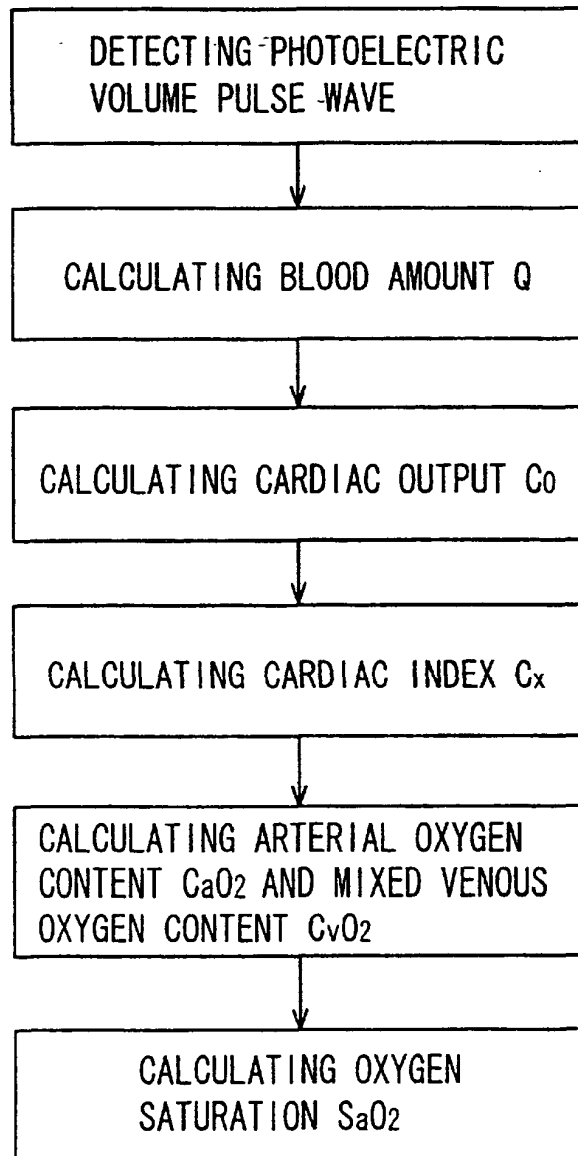

Fig. 14

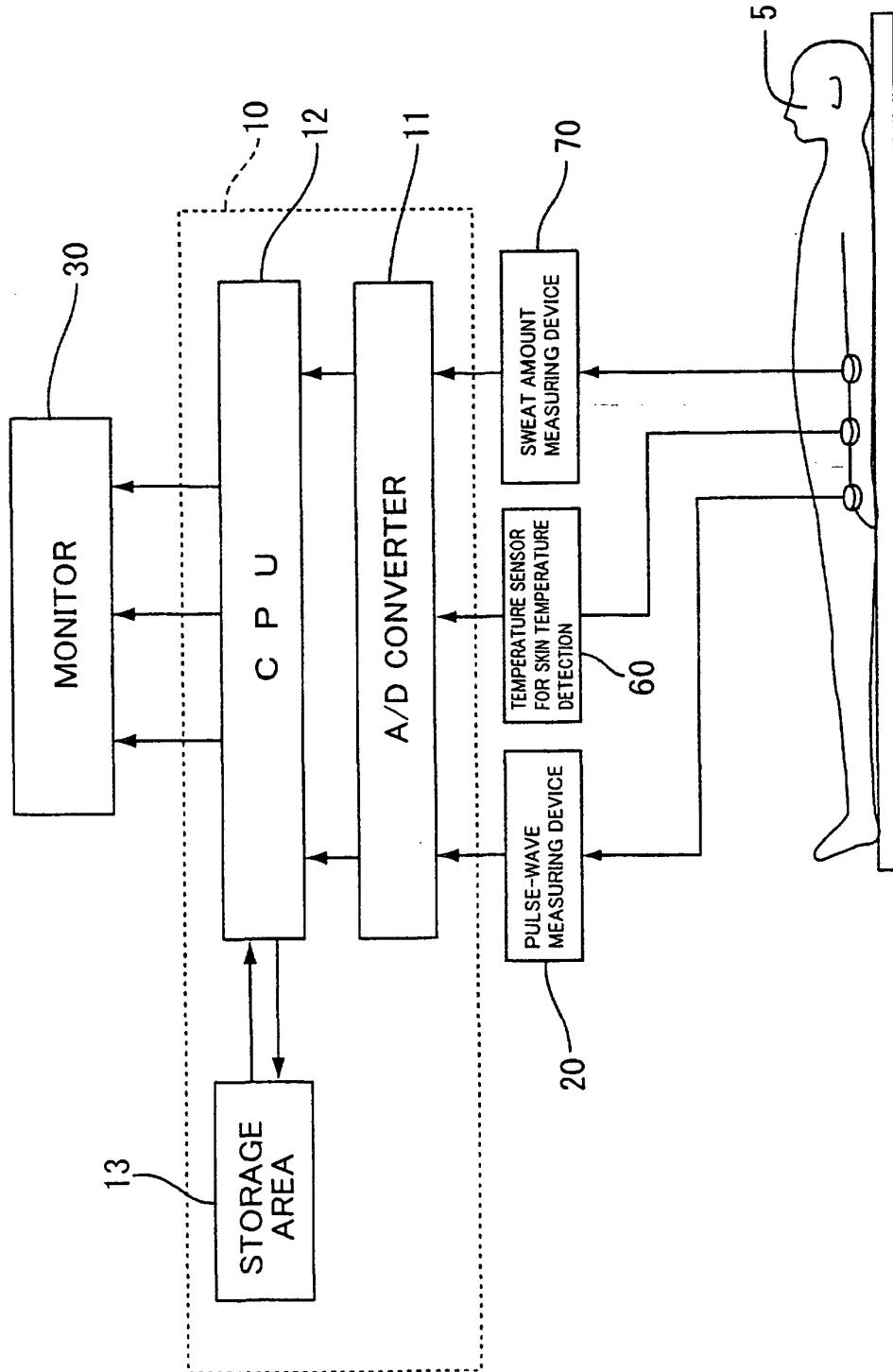

Fig. 15

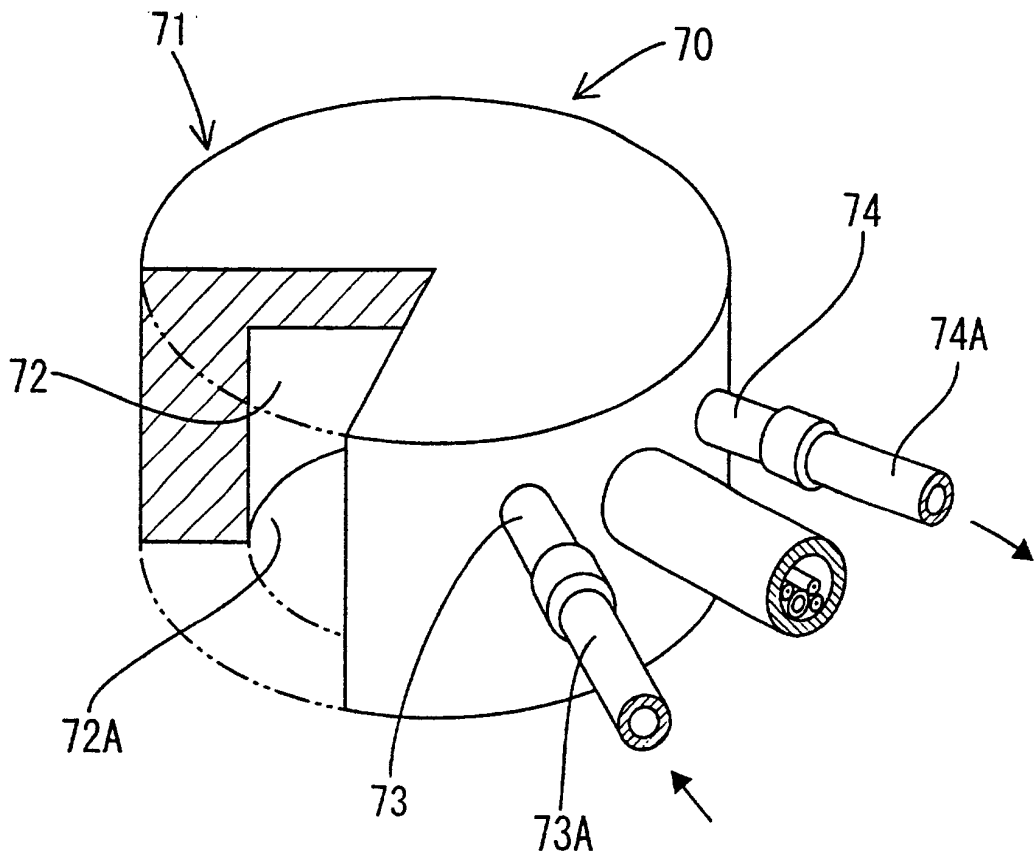

Fig. 16A

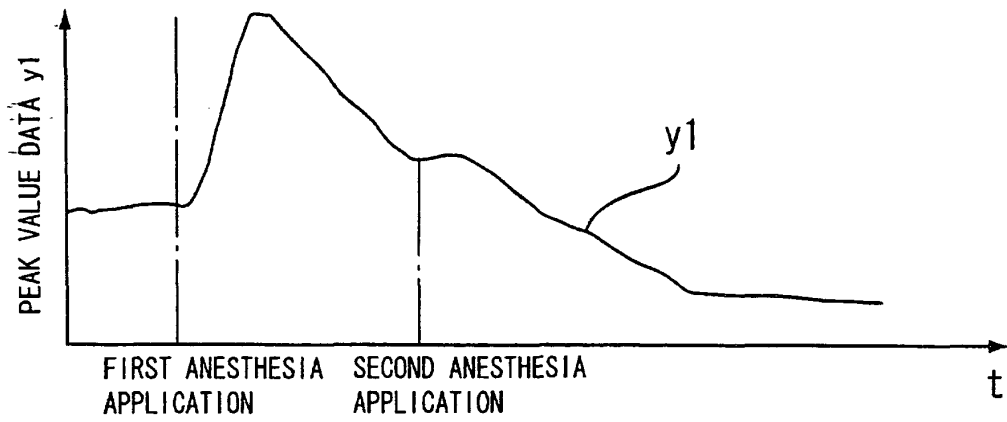

Fig. 16B

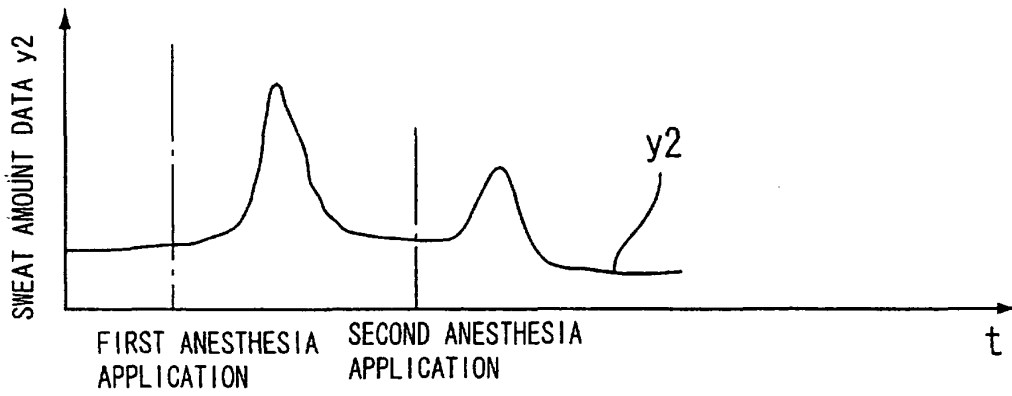

Fig. 16C

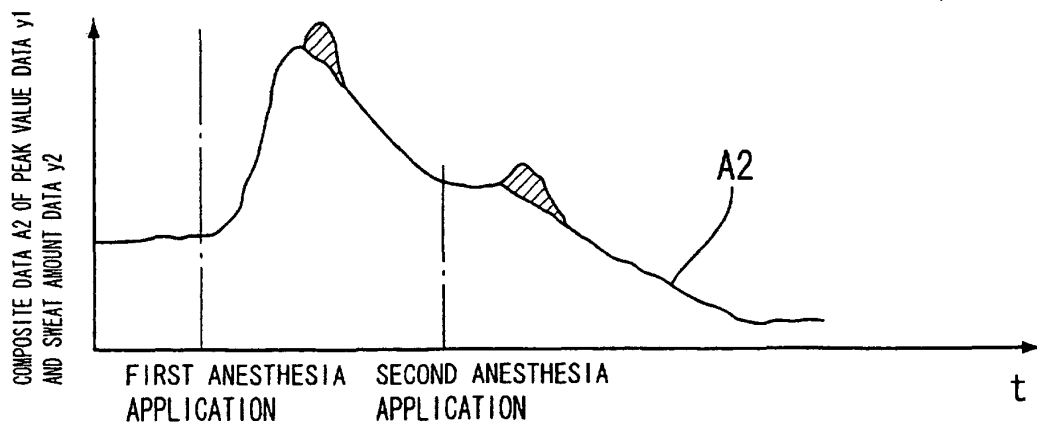
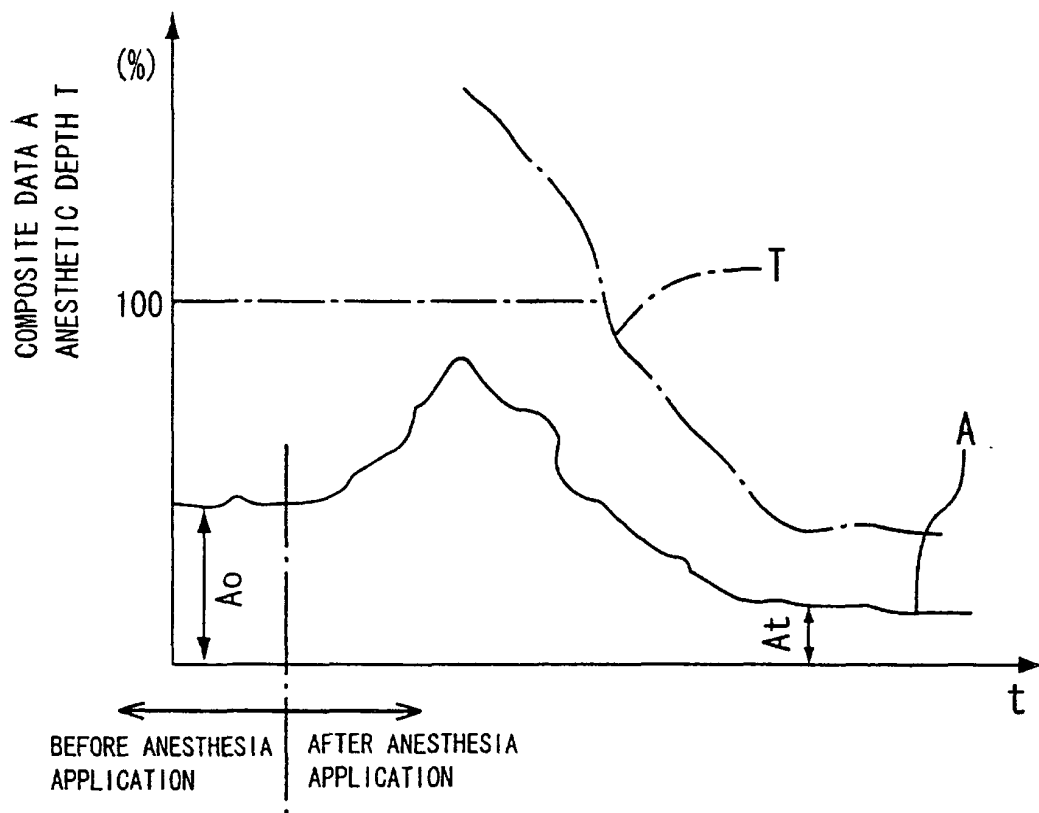

Fig. 17



$$\text{ANESTHETIC DEPTH } T = (A_0/A_t) \times 100$$

Fig. 18A

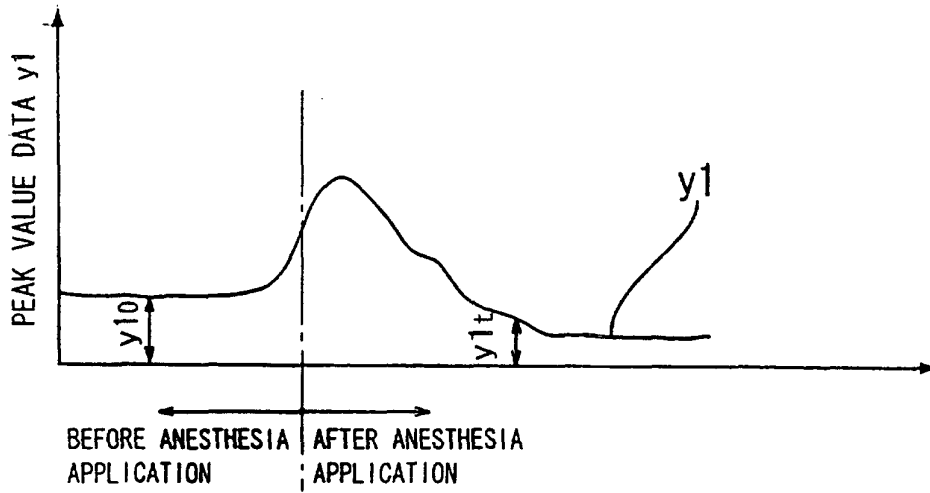
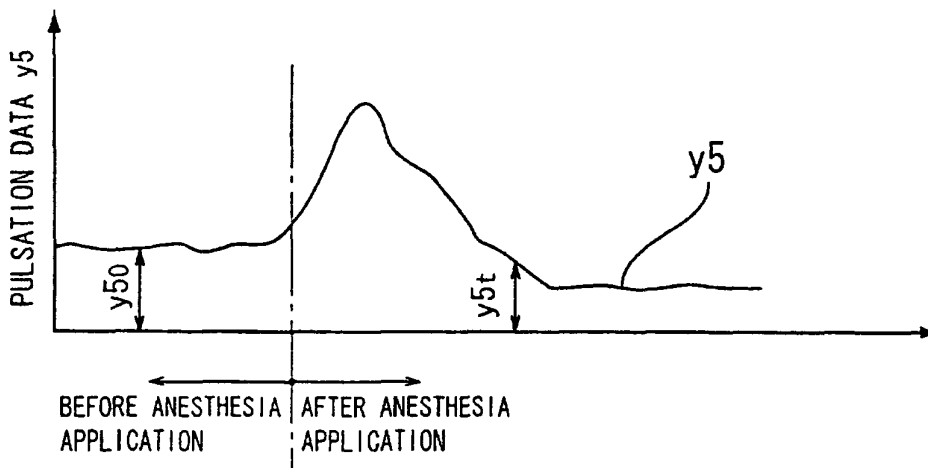

Fig. 18B



PULSATION ANESTHETIC DEPTH $T_1 = (y_{1t} \times y_{5t} - k_1 \times y_{10} \times y_{50}) / (k_2 \times y_{10} \times y_{50})$
 WHERE k_1 AND k_2 ARE CONSTANTS.

Fig. 19A

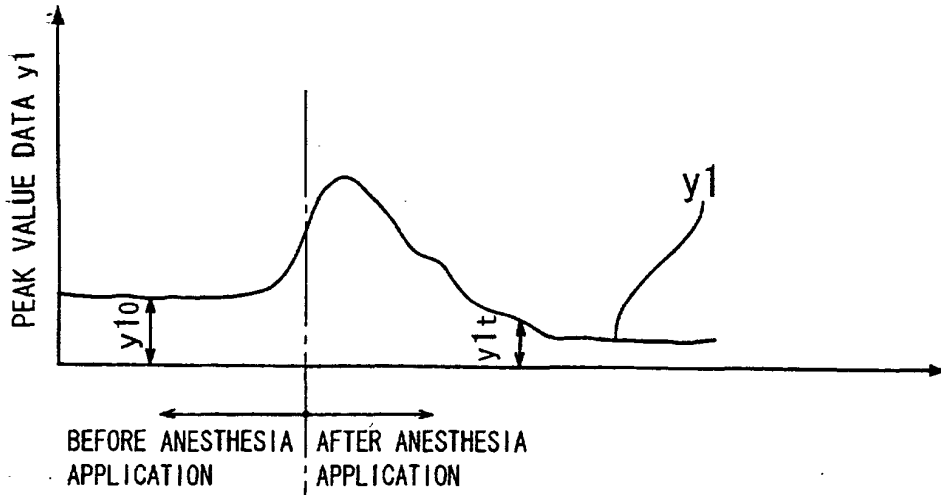
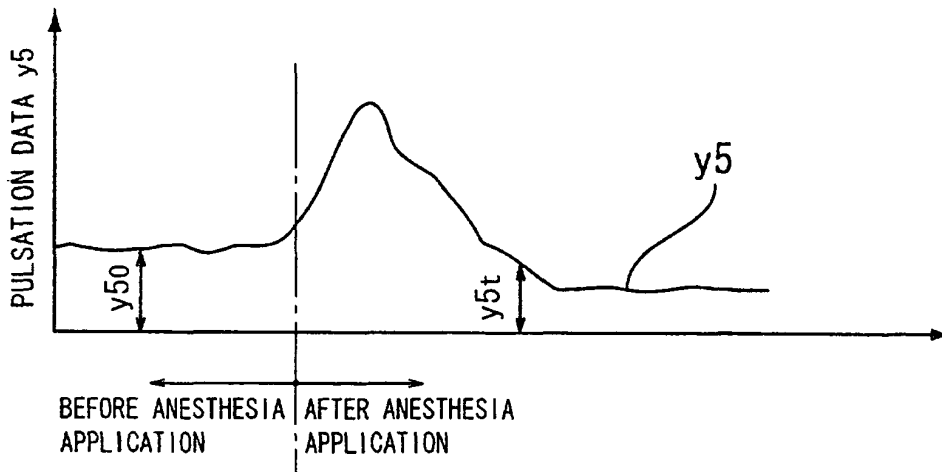

Fig. 19B



PULSATION ANESTHETIC DEPTH $T_1 = (y_{1t} \times y_{5t} - k_1 \times y_{10} \times y_{50}) / (k_2 \times y_{10} \times y_{50})$
 WHERE k_1 AND k_2 ARE CONSTANTS.

Fig. 20

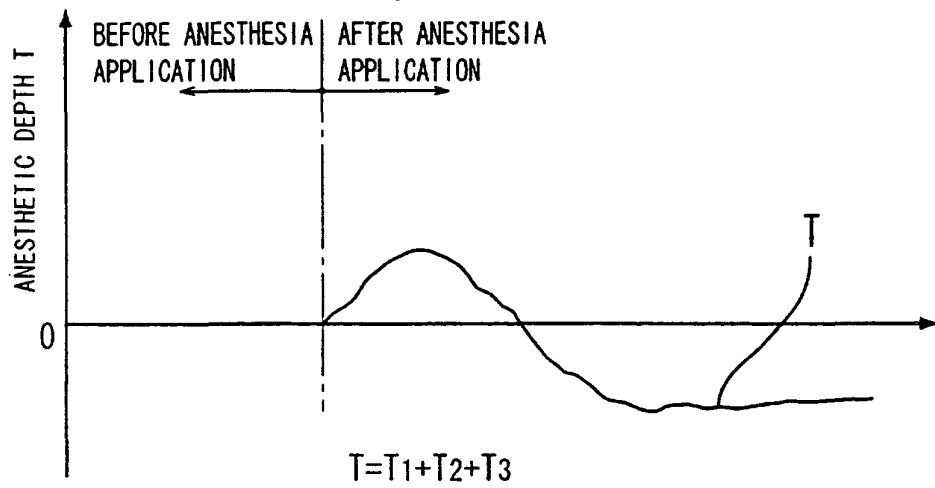

Fig. 21

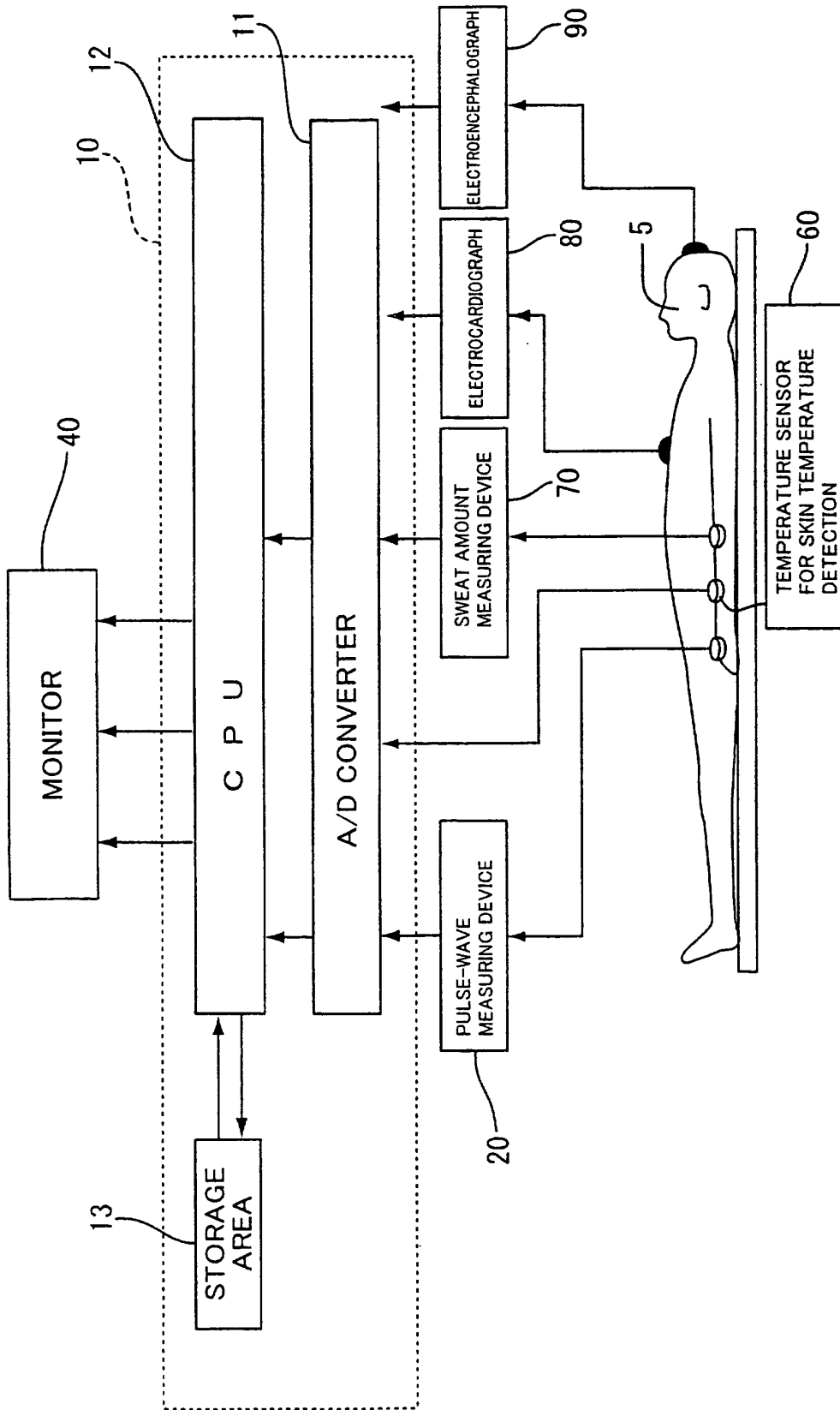

Fig. 22A

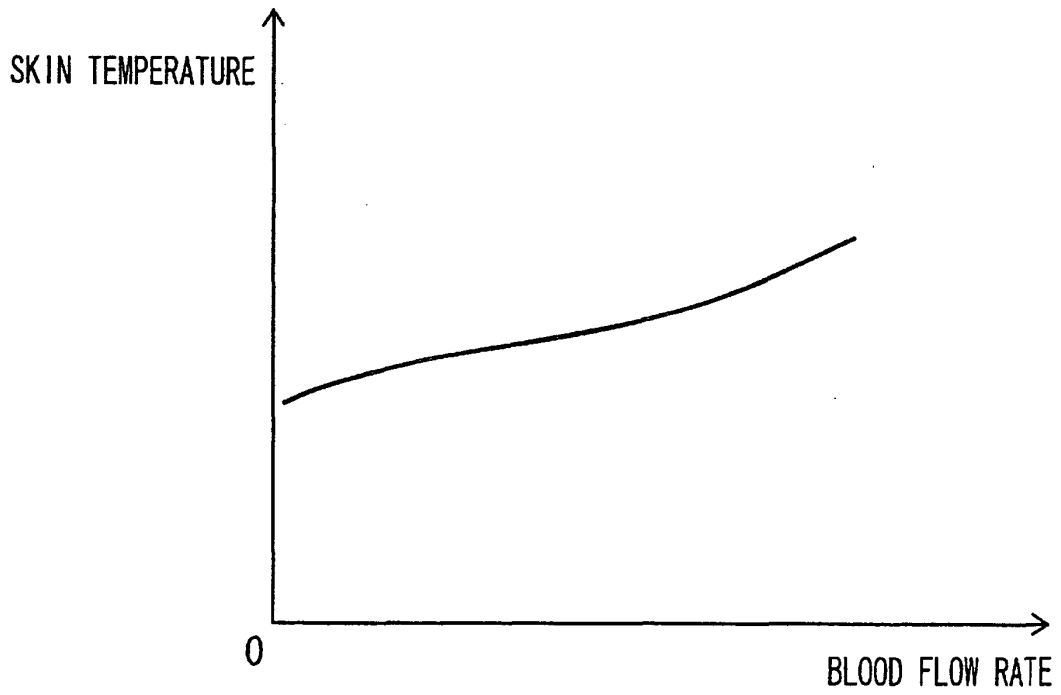
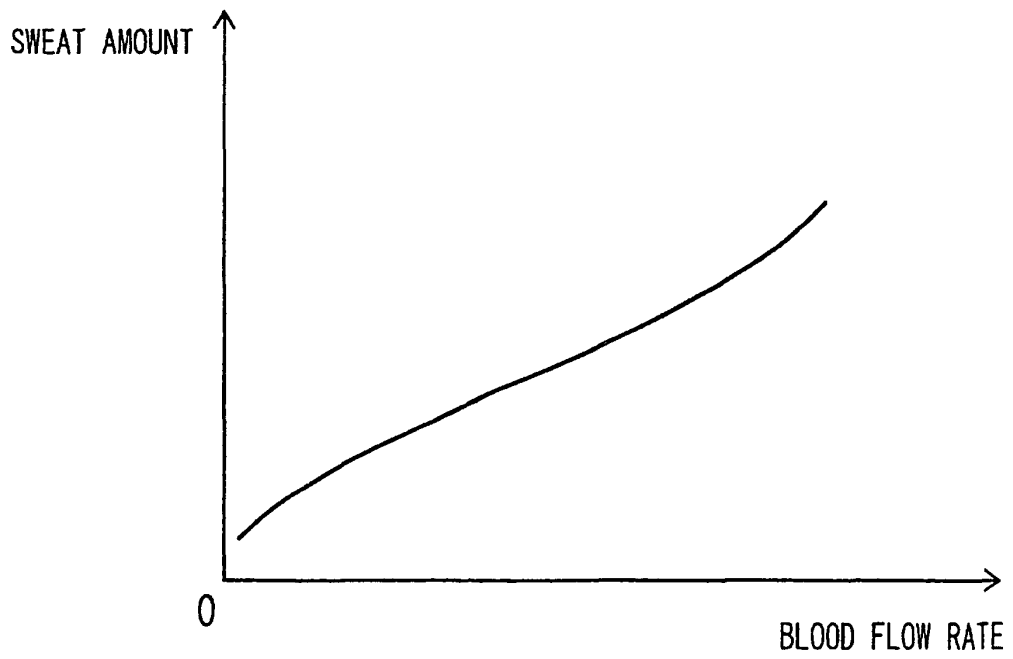

Fig. 22B



专利名称(译)	生物数据观察仪器		
公开(公告)号	EP1317902B1	公开(公告)日	2005-11-09
申请号	EP2002027552	申请日	2002-12-09
[标]申请(专利权)人(译)	KABUSHIKI GAISYA钾和硫		
申请(专利权)人(译)	KABUSHIKI该杀K-AND-S		
当前申请(专利权)人(译)	KABUSHIKI该杀K-AND-S		
[标]发明人	KONDO SHINJI SAKAKIBARA NORIAKI TAKEMOTO TORU HONDA TOSHIHIRO		
发明人	KONDO SHINJI SAKAKIBARA NORIAKI TAKEMOTO TORU HONDA TOSHIHIRO		
IPC分类号	A61B5/00 A61B5/021 A61B5/0285 G06F17/00		
CPC分类号	A61B5/0285 A61B5/021 A61B5/02108 A61B5/4266 A61B5/4821		
优先权	2001377083 2001-12-11 JP 2001375925 2001-12-10 JP 2002113656 2002-04-16 JP 2002316337 2002-10-30 JP 2002000856 2002-01-07 JP		
其他公开文献	EP1317902A1		
外部链接	Espacenet		

摘要(译)

一种生物数据观察装置，包括测量单元（26），所述测量单元至少包括光电传感器（26），所述光电传感器（26）包括用于将具有预定波长的光发射到对象（5）的血管上的发光元件（26A）和光检测元件（26B），用于检测由发光元件（26A）发出的光产生的透射或反射光量的变化作为光电体积脉冲波，存储区域（13），其中压力转换数据相关脉搏波区域和血压值，以便脉搏波区域可以转换为血压值作为绝对值，脉搏波区域是通过对每次心跳的光电体积脉冲波的波形进行积分得到的，可操作的单元根据从对象（5）获得的光电体积脉冲波计算脉搏波面积，并进一步计算基底上的对象的血压值计算出的脉搏波区域和血压转换数据的s，以及显示由操作单元（10）执行的计算结果的显示单元（30）。

