



(11) **EP 1 309 270 B1**

(12) **EUROPEAN PATENT SPECIFICATION**

(45) Date of publication and mention of the grant of the patent:  
**01.07.2009 Bulletin 2009/27**

(21) Application number: **01962370.1**

(22) Date of filing: **14.08.2001**

(51) Int Cl.:  
**A61B 5/00 (2006.01)**

(86) International application number:  
**PCT/US2001/041705**

(87) International publication number:  
**WO 2002/015781 (28.02.2002 Gazette 2002/09)**

(54) **DUAL-MODE PULSE OXIMETER**  
PULSOXIMETER MIT ZWEI BETRIEBSARTEN  
SPHYGMO-OXYMETRE BI-MODE

(84) Designated Contracting States:  
**AT BE CH CY DE DK ES FI FR GB GR IE IT LI LU MC NL PT SE TR**

(30) Priority: **18.08.2000 US 641542**

(43) Date of publication of application:  
**14.05.2003 Bulletin 2003/20**

(60) Divisional application:  
**09002646.9 / 2 064 989**

(73) Proprietor: **Masimo Corporation**  
**Irvine, CA 92614 (US)**

(72) Inventors:  
• **ALI, Ammar, Al**  
**Tustin, CA 92782 (US)**  
• **CAROTHERS, Don**  
**Mission Viejo, CA 92691 (US)**  
• **DALKE, David**  
**Irvine, CA 92614 (US)**

- **DIAB, Mohamed, K.**  
**Mission Viejo, CA 92692 (US)**
- **GOLDMAN, Julian**  
**Irvine, CA 92604 (US)**
- **KIANI, Massi, E.**  
**Laguna Niguel, CA 92677 (US)**
- **LEE, Michael**  
**Aliso Viejo, CA 92656 (US)**
- **NOVAK, Jerome**  
**Aliso Viejo, CA 92656 (US)**
- **SMITH, Robert**  
**Lake Forest, CA 92630 (US)**
- **VADEN, Val, E.**  
**Hillsborough, CA 94010 (US)**

(74) Representative: **Vossius & Partner**  
**Siebertstrasse 4**  
**81675 München (DE)**

(56) References cited:  
**EP-A- 0 601 589** **WO-A-00/42911**  
**US-A- 5 687 717** **US-A- 5 931 791**

**EP 1 309 270 B1**

Note: Within nine months of the publication of the mention of the grant of the European patent in the European Patent Bulletin, any person may give notice to the European Patent Office of opposition to that patent, in accordance with the Implementing Regulations. Notice of opposition shall not be deemed to have been filed until the opposition fee has been paid. (Art. 99(1) European Patent Convention).

**Description**

**[0001]** This invention relates in general to optical probes, and in particular to low-noise, disposable and reusable optical probes applied to the side of a digit.

**[0002]** Energy is often transmitted through or reflected from a medium to determine characteristics of the medium. For example, in the medical field, instead of extracting material from a patient's body for testing, light or sound energy may be caused to be incident to the patient's body, and transmitted or reflected energy may be measured to determine information about the material through which the energy is passed. This type of non-invasive measurement is more comfortable for the patient and can be performed more quickly.

**[0003]** Non-invasive measurements of bodily functions are often performed with optical probes. Typically, the optical probe is housed in an adhesive bandage, a reusable clip, a Velcro securing mechanism, or the like. Moreover, typically the optical probes are housed such that an emitter vertically opposes a detector over the nail of a digit, such as, for example, a finger or toe.

**[0004]** Drawbacks arise during the use of conventional optical probes during motion, or patient agitation, such as tapping or other physical depression of the digit being monitored. Such drawbacks relate to the strong reliance of optical probe technology on the optical path length. The optical path length is defined as the distance between the emitter and the detector, such as, for example, the thickness of the material through which the optical energy must pass before reaching the detector. Thus, when a patient moves in a manner that distorts or compresses the tissue of the digit through which measurement is being taken, the optical path length may change dramatically. Moreover, since patients may generally move in an erratic fashion, the compression of digits is often also erratic, resulting in an erratic change in the optical path length. Thus, patient movement often makes the absorption of optical energy erratic, resulting in difficulty with signal interpretation.

**[0005]** In addition, the conventional attachment of the emitter and the detector such that the optical path length is defined through the nail of the digit, fails to optimize the volume through which perfusion may take place. For example, the placement of the emitter and the detector defines a volume of tissue through which some optical energy will pass, and it is the perfusion through that volume that is measured by the optical probe. When the volume is defined vertically through the nail portion of the digit, the perfusion is unnecessarily limited. The limited perfusion fails to optimize the eventual signal-to-noise ratio obtained. Similar to the erratic absorption of optical energy, lower signal-to-noise ratios result in difficulty with signal interpretation.

**[0006]** Therefore, a need exists for an optical probe applied to a digit in a manner which reduces the change in optical path length during movement, increases the measured perfusion, and increases the eventual signal-to-noise ratio.

**[0007]** Oximetry is the measurement of the oxygen level status of blood. Early detection of low blood oxygen level is critical in the medical field, for example in critical care and surgical applications, because an insufficient supply of oxygen can result in brain damage and death in a matter of minutes. Pulse oximetry is a widely accepted noninvasive procedure for measuring the oxygen saturation level of arterial blood, an indicator of oxygen supply. A pulse oximetry system generally consists of a sensor applied to a patient, a pulse oximeter, and a patient cable connecting the sensor and the pulse oximeter.

**[0008]** The pulse oximeter may be a standalone device or may be incorporated as a module or built-in portion of a multiparameter patient monitoring system, which also provides measurements such as blood pressure, respiratory rate and EKG. A pulse oximeter typically provides a numerical readout of the patient's oxygen saturation, a numerical readout of pulse rate, and an audible indicator or "beep" that occurs in response to each pulse. In addition, the pulse oximeter may display the patient's plethysmograph, which provides a visual display of the patient's pulse contour and pulse rate.

**[0009]** WO-A-00142911 (MASIMO CORPORATION) discloses a pulse oximeter which has an integrated mode in which it operates as a plug-in module for a multiparameter patient monitoring system (MPMS). The pulse oximeter also has a portable mode in which operates separately from the MPMS as a battery-powered handheld or standalone instrument. The pulse oximeter has a sensor port that receives a photo-plethysmographic signal as input to an internal processor. The pulse oximeter processes this sensor signal to derive oxygen saturation and pulse rate measurements. In the portable mode, this information is provided on its display, and stored in memory for trend capability. A keypad provides a user interface for operational control in the portable mode. In the integrated mode, the pulse oximeter provides oxygen saturation and pulse rate measurements to the MPMS through a communications interface, along with previously stored trend data, and displayed on the MPMS monitor. The MPMS also provides external power and operational control of the pulse oximeter in the integrated mode. A docking station operates as a plug-in module that provides the mechanical and electrical interface between a portable pulse oximeter and MPMS instruments from a variety of manufacturers. In the integrated mode, the portable pulse oximeter docks to the docking station, which in turn is inserted in one or more MPMS slots. The docking station can function as a simple electrical pass-through device between the docked portable pulse oximeter and the MPMS or it can provide a MPMS communications interface.

**[0010]** FIG. 1 illustrates a prior art pulse oximeter **100** and associated sensor **110**. Conventionally, a pulse oximetry sensor **110** has LED emitters **112**, typically one at a red-wavelength and one at an infrared wavelength, and a photodiode

detector **114**. The sensor **110** is typically attached to an adult patient's finger or an infant patient's foot. For a finger, the sensor **110** is configured so that the emitters **112** project light through the fingernail and through the blood vessels and capillaries underneath. The LED emitters **112** are activated by drive signals **122** from the pulse oximeter **100**. The detector **114** is positioned at the fingertip opposite the fingernail so as to detect the LED emitted light as it emerges from the finger tissues. The photodiode generated signal **124** is relayed by a cable to the pulse oximeter **100**.

**[0011]** The pulse oximeter **100** determines oxygen saturation ( $SpO_2$ ) by computing the differential absorption by arterial blood of the two wavelengths emitted by the sensor **110**. The pulse oximeter **100** contains a sensor interface **120**, an  $SpO_2$  processor **130**, an instrument manager **140**, a display **150**, an audible indicator (tone generator) **160** and a keypad **170**. The sensor interface **120** provides LED drive current **122** which alternately activates the sensor red and IR LED emitters **112**. The sensor interface **120** also has input circuitry for amplification and filtering of the signal **124** generated by the photodiode detector **114**, which corresponds to the red and infrared light energy attenuated from transmission through the patient tissue site. The  $SpO_2$  processor **130** calculates a ratio of detected red and infrared intensities, and an arterial oxygen saturation value is empirically determined based on that ratio. The instrument manager **140** provides hardware and software interfaces for managing the display **150**, audible indicator **160** and keypad **170**. The display **150** shows the computed oxygen status, as described above. The audible indicator **160** provides the pulse beep as well as alarms indicating desaturation events. The keypad **170** provides a user interface for such things as alarm thresholds, alarm enablement, and display options.

**[0012]** Computation of  $SpO_2$  relies on the differential light absorption of oxygenated hemoglobin,  $HbO_2$ , and deoxygenated hemoglobin,  $Hb$ , to determine their respective concentrations in the arterial blood. Specifically, pulse oximetry measurements are made at red and IR wavelengths chosen such that deoxygenated hemoglobin absorbs more red light than oxygenated hemoglobin, and, conversely, oxygenated hemoglobin absorbs more infrared light than deoxygenated hemoglobin, for example 660 nm (red) and 905 nm (IR).

**[0013]** To distinguish between tissue absorption at the two wavelengths, the red and IR emitters **112** are provided drive current **122** so that only one is emitting light at a given time. For example, the emitters **112** may be cycled on and off alternately, in sequence, with each only active for a quarter cycle and with a quarter cycle separating the active times. This allows for separation of red and infrared signals and removal of ambient light levels by downstream signal processing. Because only a single detector **114** is used, it responds to both the red and infrared emitted light and generates a time-division-multiplexed ("modulated") output signal **124**. This modulated signal **124** is coupled to the input of the sensor interface **120**.

**[0014]** In addition to the differential absorption of hemoglobin derivatives, pulse oximetry relies on the pulsatile nature of arterial blood to differentiate hemoglobin absorption from absorption of other constituents in the surrounding tissues. Light absorption between systole and diastole varies due to the blood volume change from the inflow and outflow of arterial blood at a peripheral tissue site. This tissue site might also comprise skin, muscle, bone, venous blood, fat, pigment, etc., each of which absorbs light. It is generally assumed that the background absorption due to these surrounding tissues is relatively invariant over short time periods and can be easily removed. Thus, blood oxygen saturation measurements are based upon a ratio of the time-varying or AC portion of the detected red and infrared signals with respect to the time-invariant or DC portion:

$$RD/IR = (Red_{AC}/Red_{DC})/(IR_{AC}/IR_{DC})$$

The desired  $SpO_2$  measurement is then computed from this ratio. The relationship between  $RD/IR$  and  $SpO_2$  is most accurately determined by statistical regression of experimental measurements obtained from human volunteers and calibrated measurements of oxygen saturation. In a pulse oximeter device, this empirical relationship can be stored as a "calibration curve" in a read-only memory (ROM) look-up table so that  $SpO_2$  can be directly read-out of the memory in response to input  $RD/IR$  measurements.

**[0015]** Pulse oximetry is the standard-of-care in various hospital and emergency treatment environments. Demand has led to pulse oximeters and sensors produced by a variety of manufacturers. Unfortunately, there is no standard for either performance by, or compatibility between, pulse oximeters or sensors. As a result, sensors made by one manufacturer are unlikely to work with pulse oximeters made by another manufacturer. Further, while conventional pulse oximeters and sensors are incapable of taking measurements on patients with poor peripheral circulation and are partially or fully disabled by motion artifact, advanced pulse oximeters and sensors manufactured by the assignee of the present invention are functional under these conditions. This presents a dilemma to hospitals and other caregivers wishing to upgrade their patient oxygenation monitoring capabilities. They are faced with either replacing all of their conventional pulse oximeters, including multiparameter patient monitoring systems, or working with potentially incompatible sensors and inferior pulse oximeters manufactured by various vendors for the pulse oximetry equipment in use at the installation.

**[0016]** Hospitals and other caregivers are also plagued by the difficulty of monitoring patients as they are transported

from one setting to another. For example, a patient transported by ambulance to a hospital emergency room will likely be unmonitored during the transition from ambulance to the ER and require the removal and replacement of incompatible sensors in the ER. A similar problem is faced within a hospital as a patient is moved between surgery, ICU and recovery settings. Incompatibility and transport problems are exacerbated by the prevalence of expensive and non-portable multi-

parameter patient monitoring systems having pulse oximetry modules as one measurement parameter.  
**[0017]** One aspect of the present invention is a dual-mode physiological measurement system as defined in claim 1 having a portable mode and an integrated mode. In the integrated mode, the measurement apparatus operates in conjunction with a multiparameter patient monitoring system (MPMS). In the portable mode, the measurement apparatus operates separately from the MPMS. The measurement apparatus has a physiological measurement processor, a display, a MPMS interface and a management processor. The physiological measurement processor has a sensor input and provides a physiological measurement output. In the portable mode, the display indicates a physiological parameter according to the physiological measurement output. In the integrated mode, the MPMS interface provides a communications link between the measurement apparatus and the MPMS. The management processor has as an input the physiological measurement output. The management processor controls the display in the portable mode and communicates the measurement output to the MPMS via the MPMS interface in the integrated mode.

**[0018]** In one embodiment, the measurement apparatus described in the previous paragraph further comprises a plug-in module. The plug-in module comprises the measurement processor and the MPMS interface and possibly the display and management processor and is configured to be removably retained by and electrically connected to the MPMS in the integrated mode. The plug-in module may further comprise a patient cable connector providing the sensor input, a keypad accepting user inputs in the portable mode, and a module connector mating with a corresponding MPMS back-plane connector in the integrated mode. According to the invention, the measurement apparatus further comprises a docking station and a portable portion. The docking station has a docking portion, a plug-in portion and the MPMS interface. The plug-in portion is configured to be removably retained by and electrically connected to the MPMS. The portable portion comprises the measurement processor, the display and the management processor. In the integrated mode, the portable portion is configured to be removably retained by and electrically connected to the docking portion. In the portable-mode, the portable portion is separated from the docking station and operated as a standalone patient monitoring apparatus. The portable portion may further comprise a patient cable connector providing the sensor input, a keypad accepting user inputs in the portable mode, and a portable connector mating with a corresponding docking station connector in the integrated mode.

**[0019]** Another aspect of the present invention is a patient monitoring method as defined in claim 8 utilizing a standalone measurement apparatus and a multiparameter patient monitoring system (MPMS) comprising the steps of performing a first physiological measurement with the standalone apparatus physically and electrically isolated from the MPMS and presenting information related to the first measurement on a display portion of the standalone apparatus. Further steps include performing a second physiological measurement with the standalone apparatus interfaced to the MPMS, communicating the second physiological measurement to the MPMS, and presenting information related to the second measurement on a monitor portion of the MPMS.

**[0020]** One embodiment of the patient monitoring method described in the previous paragraph further comprises the step of plugging the measurement apparatus into a module slot portion of the MPMS so that the measurement apparatus is in electrical communications with the MPMS. Another embodiment further comprises the steps of plugging a docking station into a module slot portion of the MPMS so that the docking station is in electrical communications with the MPMS, and attaching the standalone apparatus to the docking station so that the standalone apparatus is in electrical communications with the docking station.

**[0021]** There is furthermore described a physiological measurement apparatus comprising a sensor responsive to a physiological state, a measurement processor means for calculating a physiological parameter based upon the physiological state, which presents the physiological parameter to a person, a packaging means for housing the measurement processor and the display and for providing a connection between the sensor and the measurement processor means, and an interface means for electrically connecting the packaging means to a multiparameter patient monitoring system (MPMS) in an integrated mode and for disconnecting the packaging means from the MPMS in a portable mode. In a particular embodiment, the packaging means comprises a module means for plugging into a slot portion of the MPMS. In another particular embodiment, the physiological measurement apparatus further comprises a docking station means for plugging into a slot portion of the MPMS. In the integrated mode, the packaging means is configured to attach to the docking station.

FIG. 1 is a block diagram of a prior art pulse oximeter;

FIG. 2 is a diagram illustrating a patient monitoring system incorporating a universal/upgrading pulse oximeter (UPO) according to the present invention;

FIG. 3 is top level block diagram of a UPO embodiment;

FIG. 4 is a detailed block diagram of the waveform generator portion of the UPO embodiment shown in FIG. 3;

FIG. 5 is an illustration of a handheld embodiment of the UPO;

FIG. 6 is a top level block diagram of another UPO embodiment incorporating a portable pulse oximeter and a docking station;

FIG. 7 is a detailed block diagram of the portable pulse oximeter portion of FIG. 6;

FIG. 8A is an illustration of the portable pulse oximeter user interface, including a keyboard and display;

FIGS. 8B-C are illustrations of the portable pulse oximeter display showing portrait and landscape modes, respectively;

FIG. 9 is a detailed block diagram of the docking station portion of FIG. 6;

FIG. 10 is a schematic of the interface cable portion of FIG. 6;

FIG. 11A is a front view of an embodiment of a portable pulse oximeter;

FIG. 11B is a back view of a portable pulse oximeter;

FIG. 12A is a front view of an embodiment of a docking station;

FIG. 12B is a back view of a docking station;

FIG. 13 is a front view of a portable docked to a docking station;

FIG. 14 is a block diagram of one embodiment of a local area network interface for a docking station;

FIG. 15 is a perspective view of a patient care bed incorporating a docking station;

FIG. 16 is a block diagram of a docking station integrated into a patient care bed;

FIGS. 17A-B are front and back perspective views of a dual-mode pulse oximeter module according to the present invention;

FIG. 18 is a block diagram of the dual-mode pulse oximeter module;

FIG. 19 is a perspective view of a docking station module according to the present invention;

FIG. 20 is a perspective view of the docking station module of FIG. 19 attached to a multiparameter patient monitoring system (MPMS);

FIG. 21 is a block diagram of a pass-through docking station module; and

FIG. 22 is a block diagram of a docking station module providing an MPMS interface.

**[0022]** FIG. 2 depicts the use of a Universal/Upgrading Pulse Oximeter ("UPO") 210 to perform patient monitoring. A pulse oximetry sensor 110 is attached to a patient (not illustrated) and provides the UPO 210 with a modulated red and IR photo-plethysmograph signal through a patient cable 220. It should be understood that while a pulse oximeter is illustrated, the present invention has applicability to other physiological parameter such as ECG, blood pressure, respiration, etc. The UPO 210 computes the patient's oxygen saturation and pulse rate from the sensor signal and, optionally, displays the patient's oxygen status. The UPO 210 may incorporate an internal power source 212, such as common alkaline batteries or a rechargeable power source. The UPO 210 may also utilize an external power source 214, such as standard 110V AC coupled with an external step-down transformer and an internal or external AC-to-DC converter.

**[0023]** In addition to providing pulse oximetry measurements, the UPO 210 also separately generates a signal, which is received by a pulse oximeter 260 external to the UPO 210. This signal is synthesized from the saturation calculated by the UPO 210 such that the external pulse oximeter 260 calculates the equivalent saturation and pulse rate as computed by the UPO 210. The external pulse oximeter receiving the UPO signal may be a multiparameter patient monitoring system (MPMS) 250 incorporating a pulse oximeter module 260, a standalone pulse oximeter instrument, or any other host instrument capable of measuring SpO<sub>2</sub>.

**[0024]** As shown in FIG. 2, a MPMS 250 typically has a chassis 270, a multiparameter monitor 280, a processor 1894 (FIG. 18) and a power supply 1892 (FIG. 18), which derives power from a standard external AC power source. The monitor 280 typically incorporates a display 282. The chassis 270 typically has various slots 290 each configured to receive a plug-in module 298. A module connector, e.g. the connector 1750 (FIG. 17B) on the dual-mode pulse oximeter module described with respect to FIGS. 17A-B, below, mates and electrically connects with a corresponding backplane connector (not shown) within the chassis 270. A variety of modules having various patient monitoring functions, such as blood pressure, EKG, respiratory gas and pulse oximetry 260 can be plugged into the slots 290 so that the associated patient parameters can be jointly monitored by the MPMS 250 and logged on the multiparameter display 282.

**[0025]** Also shown in FIG. 2, the UPO 210 is connected to an existing MPMS 250 with a cable 230, advantageously integrating the UPO oxygen status measurements with other MPMS measurements. This allows the UPO calculations to be shown on a unified display of important patient parameters, networked with other patient data, archived within electronic patient records and incorporated into alarm management, which are all MPMS functions convenient to the caregiver.

**[0026]** FIG. 3 depicts a block diagram of the major functions of the UPO 210, including an internal pulse oximeter 310, a waveform generator 320, a power supply 330 and an optional display 340. Attached to the UPO 210 is a sensor 110 and an external pulse oximeter 260. The internal pulse oximeter 310 provides the sensor 110 with a drive signal 312 that alternately activates the sensor's red and IR LEDs, as is known in the art. A corresponding detector signal 314 is received by the internal pulse oximeter 310. The internal pulse oximeter 310 computes oxygen saturation, pulse rate,

and, in some embodiments, other physiological parameters such as pulse occurrence, plethysmograph features and measurement confidence. These parameters **318** are output to the waveform generator **320**. A portion of these parameters may also be used to generate display drive signals **316** so that patient status may be read from, for example, an LED or LCD display module **340** on the UPO.

**[0027]** The internal pulse oximeter **310** may be a conventional pulse oximeter or, for upgrading an external pulse oximeter **260**, it may be an advanced pulse oximeter capable of low perfusion and motion artifact performance not found in conventional pulse oximeters. An advanced pulse oximeter for use as an internal pulse oximeter **310** is described in U.S. Patent No. 5,632,272 assigned to the assignee of the present invention. An advanced pulse oximetry sensor for use as the sensor **110** attached to the internal pulse oximeter **310** is described in U.S. Patent No. 5,638,818 assigned to the assignee of the present invention. Further, a line of advanced Masimo SET<sup>®</sup> pulse oximeter OEM boards and sensors are available from the assignee of the present invention.

**[0028]** The waveform generator **320** synthesizes a waveform, such as a triangular waveform having a sawtooth or symmetric triangle shape, that is output as a modulated signal **324** in response to an input drive signal **322**. The drive input **322** and modulation output **324** of the waveform generator **320** are connected to the sensor port **262** of the external pulse oximeter **260**. The synthesized waveform is generated in a manner such that the external pulse oximeter **260** computes and displays a saturation and a pulse rate value that is equivalent to that measured by the internal pulse oximeter **310** and sensor **110**. In the present embodiment, the waveforms for pulse oximetry are chosen to indicate to the external pulse oximeter **260** a perfusion level of 5%. The external pulse oximeter **260**, therefore, always receives a strong signal. In an alternative embodiment, the perfusion level of the waveforms synthesized for the external pulse oximeter can be set to indicate a perfusion level at or close to the perfusion level of the patient being monitored by the internal pulse oximeter **310**. As an alternative to the generated waveform, a digital data output **326**, is connected to the data port **264** of the external pulse oximeter **260**. In this manner, saturation and pulse rate measurements and also samples of the unmodulated, synthesized waveform can be communicated directly to the external pulse oximeter **260** for display, bypassing the external pulse oximeter's signal processing functions. The measured plethysmograph waveform samples output from the internal pulse oximeter **310** also may be communicated through the digital data output **326** to the external pulse oximeter **260**.

**[0029]** It will be understood from the above discussion that the synthesized waveform is not physiological data from the patient being monitored by the internal pulse oximeter **310**, but is a waveform synthesized from predetermined stored waveform data to cause the external pulse oximeter **260** to calculate oxygen saturation and pulse rate equivalent to or generally equivalent (within clinical significance) to that calculated by the internal pulse oximeter **310**. The actual physiological waveform from the patient received by the detector is not provided to the external pulse oximeter **260** in the present embodiment. Indeed, the waveform provided to the external pulse oximeter will usually not resemble the plethysmographic waveform of physiological data from the patient being monitored by the internal pulse oximeter **310**.

**[0030]** The cable **230** (FIG. 2) attached between the waveform generator **320** and external pulse oximeter **260** provides a monitor ID **328** to the UPO, allowing identification of predetermined external pulse oximeter calibration curves. For example, this cable may incorporate an encoding device, such as a resistor, or a memory device, such as a PROM **1010** (FIG. 10) that is read by the waveform generator **320**. The encoding device provides a value that uniquely identifies a particular type of external pulse oximeter **260** having known calibration curve, LED drive and modulation signal characteristics. Although the calibration curves of the external pulse oximeter **260** are taken into account, the wavelengths of the actual sensor **110** need not correspond to the particular calibration curve indicated by the monitor ID **328** or otherwise assumed for the external pulse oximeter **260**. That is, the wavelength of the sensor **110** attached to the internal pulse oximeter **310** is not relevant or known to the external pulse oximeter **260**.

**[0031]** FIG. 4 illustrates one embodiment of the waveform generator portion **320** of the UPO **210** (FIG. 3). Although this illustration may suggest a hardware implementation, the functions of the waveform generator may be implemented in software or firmware or a combination of hardware, software and firmware. The waveform generator **320** performs waveform synthesis with a waveform look-up table ("LUT") **410**, a waveform shaper **420** and a waveform splitter **430**. The waveform LUT **410** is advantageously a memory device, such as a ROM (read only memory) that contains samples of one or more waveform portions or segments containing a single waveform. These stored waveform segments may be as simple as a single period of a triangular waveform, having a sawtooth or symmetric triangle shape, or more complicated, such as a simulated plethysmographic pulse having various physiological features, for example rise time, fall time and dicrotic notch.

**[0032]** The waveform shaper **420** creates a continuous repeated waveform from the waveform segments provided by the waveform LUT **410**. The waveform shaper **420** has a shape parameter input **422** and an event indicator input **424** that are buffered **470** from the parameters **318** output from the internal pulse oximeter **310** (FIG. 3). The shape parameter input **422** determines a particular waveform segment in the waveform LUT **410**. The chosen waveform segment is specified by the first address transmitted to the waveform LUT **410** on the address lines **426**. The selected waveform segment is sent to the waveform shaper **420** as a series of samples on the waveform data lines **412**.

**[0033]** The event indicator input **424** specifies the occurrence of pulses in the plethysmograph waveform processed

by the internal pulse oximeter **310** (FIG. 3). For example, the event indicator may be a delta time from the occurrence of a previously detected falling pulse edge or this indicator could be a real time or near real time indicator or flag of the pulse occurrence. The waveform shaper **420** accesses the waveform LUT **410** to create a corresponding delta time between pulses in the synthesized waveform output **428**. In one embodiment, the waveform shaper is clocked at a predetermined sample rate. From a known number of samples per stored waveform segment and the input delta time from the event indicator, the waveform shaper **420** determines the number of sequential addresses to skip between samples and accesses the waveform LUT **410** accordingly. This effectively "stretches" or "shrinks" the retrieved waveform segment so as to fit in the time between two consecutive pulses detected by the UPO.

**[0034]** The waveform splitter **430** creates a first waveform **432** corresponding to a first waveform (such a red wavelength) expected by the external pulse oximeter **260** (Fig. 3) and a second waveform (such as infrared) **434** expected by the external pulse oximeter **260**. The relative amplitudes of the first waveform **432** and second waveform **434** are adjusted to correspond to the ratio output **444** from a calibration curve LUT **440**. Thus, for every value of measured oxygen saturation at the sat input **442**, the calibration curve LUT **440** provides a corresponding ratio output **444** that results in the first waveform **432** and the second waveform **434** having an amplitude ratio that will be computed by the external pulse oximeter **260** (FIG. 3) as equivalent to the oxygen saturation measured by the internal pulse oximeter **310** (FIG. 3).

**[0035]** As described above, one particularly advantageous aspect of the UPO is that the operating wavelengths of the sensor **110** (FIG. 3) are not relevant to the operating wavelengths required by the external pulse oximeter **260** (FIG. 3), i.e. the operating wavelengths that correspond to the calibration curve or curves utilized by the external pulse oximeter. The calibration curve LUT **440** simply permits generation of a synthesized waveform as expected by the external oximeter **260** (FIG. 3) based on the calibration curve used by the external pulse oximeter **260** (FIG. 3). The calibration curve LUT **440** contains data about the known calibration curve of the external pulse oximeter **260** (FIG. 3), as specified by the monitor ID input **328**. In other words, the waveform actually synthesized is not a patient plethysmographic waveform. It is merely a stored waveform that will cause the external pulse oximeter to calculate the proper oxygen saturation and pulse rate values. Although this does not provide a patient plethysmograph on the external pulse oximeter for the clinician, the calculated saturation and pulse rate values, which is what is actually sought, will be accurate.

**[0036]** A modulator **450** responds to an LED drive input **322** from the external pulse oximeter to generate a modulated waveform output **324** derived from the first waveform **432** and second waveform **434**. Also, a data communication interface **460** transmits as a digital data output **326** the data obtained from the sat **442**, pulse rate **462** and synthesized waveform **428** inputs.

**[0037]** FIG. 5 depicts a handheld UPO **500** embodiment. The handheld UPO **500** has keypad inputs **510**, an LCD display **520**, an external power supply input **530**, an output port **540** for connection to an external pulse oximeter and a sensor input **550** at the top edge (not visible). The display **520** shows the measured oxygen saturation **522**, the measured pulse rate **524**, a pulsating bar **526** synchronized with pulse rate or pulse events, and a confidence bar **528** indicating confidence in the measured values of saturation and pulse rate. Also shown are low battery **572** and alarm enabled **574** status indicators.

**[0038]** The handheld embodiment described in connection with FIG. 5 may also advantageously function in conjunction with a docking station that mechanically accepts, and electrically connects to, the handheld unit. The docking station may be co-located with a patient monitoring system and connected to a corresponding SpO<sub>2</sub> module sensor port, external power supply, printer and telemetry device, to name a few options. In this configuration, the handheld UPO may be removed from a first docking station at one location to accompany and continuously monitor a patient during transport to a second location. The handheld UPO can then be conveniently placed into a second docking station upon arrival at the second location, where the UPO measurements are displayed on the patient monitoring system at that location.

**[0039]** FIG. 6 shows a block diagram of a UPO embodiment, where the functions of the UPO **210** are split between a portable pulse oximeter **610** and a docking station **660**. The portable pulse oximeter **610** ("portable") is a battery operated, fully functional, stand-alone pulse oximeter instrument. The portable **610** connects to a sensor **110** (FIG. 2) through a UPO patient cable **220** (FIG. 2) attached to a patient cable connector **618**. The portable **610** provides the sensor **110** with a drive signal **612** that alternately activates the sensor's red and IR LEDs, as is well-known in the art. The portable also receives a corresponding detector signal **614** from the sensor. The portable can also input a sensor ID on the drive signal line **612**, as described in U.S. Patent No. 5,758,644 entitled Manual and Automatic Probe Calibration, assigned to the assignee of the present invention.

**[0040]** The portable **610** can be installed into the docking station **660** to expand its functionality. When installed, the portable **610** can receive power **662** from the docking station **660** if the docking station **660** is connected to external power **668**. Alternately, with no external power **668** to the docking station **660**, the portable **610** can supply power **662** to the docking station **660**. The portable **610** communicates to the docking station with a bi-directional serial data line **664**. In particular, the portable **610** provides the docking station with SpO<sub>2</sub>, pulse rate and related parameters computed from the sensor detector signal **614**. When the portable **610** is installed, the docking station **660** may drive a host instrument **260** (FIG. 2) external to the portable **610**. Alternatively, the portable **610** and docking station **660** combination

may function as a standalone pulse oximeter instrument, as described below with respect to FIG. 13.

[0041] In one embodiment, the docking station 660 does not perform any action when the portable 610 is not docked. The user interface for the docking station 660, i.e. keypad and display, is on the portable 610 in the present embodiment. An indicator LED on the docking station 660 is lit when the portable is docked. The docking station 660 generates a detector signal output 674 to the host instrument 260 (FIG. 2) in response to LED drive signals 672 from the host instrument and SpO<sub>2</sub> values and related parameters, received from the portable 610. The docking station 660 also provides a serial data output 682, a nurse call 684 and an analog output 688.

[0042] An interface cable 690 connects the docking station 660 to the host instrument. The LED drive signals 672 and detector signal output 674 are communicated between the docking station 660 and the host instrument 260 (FIG. 2) via the interface cable 690. The interface cable 690 provides a sync data output 692 to the docking station 660, communicating sensor, host instrument (e.g. monitor ID 328, FIG. 3) and calibration curve data. Advantageously, this data allows the docking station 660 to provide signals to a particular host instrument on which it can operate.

[0043] FIG. 7 provides further detail of the portable 610. The portable components has a pulse oximeter processor 710, a management processor 720, a power supply 730, a display 740 and a keypad 750. The pulse oximeter processor 710 functions as an internal pulse oximeter, interfacing the portable to a sensor 110 (FIG. 2) and deriving SpO<sub>2</sub>, pulse rate, a plethysmograph and a pulse indicator. An advanced pulse oximeter for use as the pulse oximeter processor 710 is described in U.S. Patent No. 5,632,272, referenced above. An advanced pulse oximetry sensor for use as the sensor 110 (FIG. 2) attached to the pulse oximeter processor 710 is described in U.S. Patent No. 5,638,818, also referenced above. Further, a line of advanced Masimo SET<sup>®</sup> pulse oximeter OEM boards and sensors are available from the assignee of the present invention. In one embodiment, the pulse oximeter processor 710 is the Masimo SET<sup>®</sup> MS-3L board or a low power MS-5 board available from Masimo Corporation.

[0044] The management processor 720 controls the various functions of the portable 610, including asynchronous serial data communications 724 with the pulse oximeter processor 710 and synchronous serial communications 762 with the docking station 660 (FIG. 6). The physical and electrical connection to the docking station 660 (FIG. 6) is via a docking station connector 763 and the docking station interface 760, respectively. The processor 720 utilizes a real-time clock 702 to keep the current date and time, which includes time and date information that is stored along with SpO<sub>2</sub> parameters to create trend data. In one embodiment, the processor of the portable 610 and the docking station 660 (FIG. 6) can be from the same family of processors to share common routines and minimize code development time.

[0045] The processor 720 also controls the user interface 800 (FIG. 8A) by transferring display data 742 to the display 740, including display updates and visual alarms, and by interpreting keystroke data 752 from the keypad 750. The processor 720 generates various alarm signals, when required, via an enable signal 728, which controls a speaker driver 770. The speaker driver 770 actuates a speaker 772, which provides audible indications such as, for example, alarms and pulse beeps. The processor 720 also monitors system status, which includes battery status 736, indicating battery levels, and docked status 764, indicating whether the portable 610 is connected to the docking station 660 (FIG. 6). When the portable 610 is docked and is on, the processor 720 also decides when to turn on or off docking station power 732.

[0046] Advantageously, the caregiver can set (i.e. configure or program) the behavior of the portable display 740 and alarms when the docked portable 610 senses that an interface cable 690 has connected the docking station 660 to an external pulse oximeter, such as a multiparameter patient monitoring system. In one user setting, for example, the portable display 740 stops showing the SpO<sub>2</sub> 811 (FIG. 8) and pulse rate 813 (FIG. 8) values when connected to an external pulse oximeter to avoid confusing the caregiver, who can read equivalent values on the patient monitoring system. The display 740, however, continues to show the plethysmograph 815 (FIG. 8) and visual pulse indicator 817 (FIG. 8) waveforms. For one such user setting, the portable alarms remain active.

[0047] Another task of the processor 720 includes maintenance of a watchdog function. The watchdog 780 monitors processor status on the watchdog data input 782 and asserts the :P reset output 784 if a fault is detected. This resets the management processor 720, and the fault is indicated with audible and visual alarms.

[0048] The portable 610 gets its power from batteries in the power supply 730 or from power 766 supplied from the docking station 660 (FIG. 6) via the docking station interface 760. A power manager 790 monitors the on/off switch on the keypad 750 and turns-on the portable power accordingly. The power manager 790 turns off the portable on command by the processor 720. DC/DC converters within the power supply 730 generate the required voltages 738 for operation of the portable 610 and docking station power 732. The portable batteries are preferably rechargeable batteries or another renewable power source. The batteries of the power supply 730 supply docking station power 732 when the docking station 660 (FIG. 6) is without external power. A battery charger within the docking station power supply provides charging current 768 to rechargeable batteries within the power supply 730. The docking station power supply 990 (FIG. 9) monitors temperature 734 from a thermistor in the rechargeable battery pack, providing an indication of battery charge status.

[0049] A non-volatile memory 706 is connected to the management processor 720 via a high-speed bus 722. In the present embodiment, the memory 706 is an erasable and field re-programmable device used to store boot data, man-

ufacturing serial numbers, diagnostic failure history, adult SpO<sub>2</sub> and pulse rate alarm limits, neonate SpO<sub>2</sub> and pulse rate alarm limits, SpO<sub>2</sub> and pulse rate trend data, and program data. Other types of non-volatile memory are well known. The SpO<sub>2</sub> and pulse rate alarm limits, as well as SpO<sub>2</sub> related algorithm parameters, may be automatically selected based on the type of sensor **110** (FIG. 2), adult or neonate, connected to the portable **610**.

**[0050]** The LCD display **740** employs LEDs for a backlight to increase its contrast ratio and viewing distance when in a dark environment. The intensity of the backlight is determined by the power source for the portable **610**. When the portable **610** is powered by either a battery pack within its power supply **730** or a battery pack in the docking station power supply **990** (FIG. 9), the backlight intensity is at a minimum level. When the portable **610** is powered by external power **668** (FIG. 6), the backlight is at a higher intensity to increase viewing distance and angle. In one embodiment, a button on the portable permits overriding these intensity settings, and provides adjustment of the intensity. The backlight is controlled in two ways. Whenever any key is pressed, the backlight is illuminated for a fixed number of seconds and then turns off, except when the portable is docked and derives power from an external source. In that case, the backlight is normally on unless deactivated with a key on the portable **610**.

**[0051]** FIG. 8A illustrates the portable user interface **800**, which includes a display **740** and a keypad **750**. In one embodiment, the display **740** is an LCD device having **160** pixels by **480** pixels. The display **740** can be shown in portrait mode, illustrated in FIG. 8B, or in landscape mode, illustrated in FIG. 8C. A tilt (orientation) sensor **950** (FIG. 9) in the docking station **660** (FIG. 6) or a display mode key on the portable **610** (FIG. 6) determines portrait or landscape mode. The tilt sensor **950** (FIG. 9) can be a gravity-activated switch or other device responsive to orientation and can be alternatively located in the portable **610** (FIG. 6). In a particular embodiment, the tilt sensor **950** (FIG. 9) is a non-mercury tilt switch, part number CW 1300-1, available from Comus International, Nutley, NJ ([www.comus-intl.com](http://www.comus-intl.com)). The tilt sensor **950** (FIG. 9) could also be a mercury tilt switch.

**[0052]** Examples of how the display area can be used to display SpO<sub>2</sub> **811**, pulse rate **813**, a plethysmographic waveform **815**, a visual pulse indicator **817** and soft key icons **820** in portrait and landscape mode are shown in FIGS. 8B and 8C, respectively. The software program of the management processor **720** (FIG. 7) can be easily changed to modify the category, layout and size of the display information shown in FIGS. 8B-C. Other advantageous information for display is SpO<sub>2</sub> limits, alarm limits, alarm disabled, exception messages and battery status.

**[0053]** The keypad **750** includes soft keys **870** and fixed keys **880**. The fixed keys **880** each have a fixed function. The soft keys **870** each have a function that is programmable and indicated by one of the soft key icons **820** located next to the soft keys **870**. That is, a particular one of the soft key icons **820** is in proximity to a particular one of the soft keys **870** and has a text or a shape that suggests the function of that particular one of the soft keys **870**. In one embodiment, the button portion of each key of the keypad **750** is constructed of florescent material so that the keys **870**, **880** are visible in the dark.

**[0054]** In one embodiment, the keypad **750** has one row of four soft keys **870** and one row of three fixed keys **880**. Other configurations are, of course, available, and specific arrangement is not significant. In one embodiment, the functions of the three fixed keys **880** are power, alarm silence and light/contrast. The power function is an on/off toggle button. The alarm silence function and the light/contrast function have dual purposes depending on the duration of the key press. A momentary press of the key corresponding to the alarm silence function will disable the audible alarm for a fixed period of time. To disable the audible alarm indefinitely, the key corresponding to the alarm silence function is held down for a specified length of time. If the key corresponding to the alarm silence function is pressed while the audible alarm has been silenced, the audible alarm is reactivated. If the key corresponding to the light/contrast function is pressed momentarily, it is an on/off toggle button for the backlight. If the key corresponding to the light/contrast function is held down, the display contrast cycles through its possible values.

**[0055]** In the present embodiment, the default functions of the four soft keys **870** are pulse beep up volume, pulse beep down volume, menu select, and display mode. These functions are indicated on the display by the up arrow, down arrow, "menu" and curved arrow soft key icons **820**, respectively. The up volume and down volume functions increase or decrease the audible sound or "beep" associated with each detected pulse. The display mode function rotates the display **740** through all four orthogonal orientations, including portrait mode (FIG. 8B) and landscape mode (FIG. 8C), with each press of the corresponding key. The menu select function allows the functionality of the soft keys **870** to change from the default functions described above. Examples of additional soft key functions that can be selected using this menu feature are set SpO<sub>2</sub> high/low limit, set pulse rate high/low limit, set alarm volume levels, set display to show trend data, print trend data, erase trend data, set averaging time, set sensitivity mode, perform synchronization, perform rechargeable battery maintenance (deep discharge/recharge to remove battery memory), and display product version number.

**[0056]** FIG. 9 provides further details of the docking station **660**, which includes a docking station processor **910**, a non-volatile memory **920**, a waveform generator **930**, a PROM interface **940**, a tilt sensor **950**, a portable interface **970** and associated connector **972**, status indicators **982**, a serial data port **682**, a nurse call output **684**, an analog output **688** and a power supply **990**. In one embodiment, the docking station **660** is intended to be associated with a fixed (non-transportable) host instrument, such as a multiparameter patient monitoring instrument in a hospital emergency room.

In a transportable embodiment, the docking station **660** is movable, and includes a battery pack within the power supply **990**.

**[0057]** The docking station processor **910** orchestrates the activity on the docking station **660**. The processor **910** provides the waveform generator **930** with parameters **932** as discussed above for Figures **3** and **4**. The processor **910** also provides asynchronous serial data **912** for communications with external devices and synchronous serial data **971** for communications with the portable **610** (FIG. **6**). In addition, the processor **910** determines system status including sync status **942**, tilt status **952** and power status **992**. The portable management processor **720** (FIG. **7**) performs the watchdog function for the docking station processor **910**. The docking station processor **910** sends watchdog messages to the portable processor **720** (FIG. **7**) as part of the synchronous serial data **972** to ensure the correct operation of the docking station processor **910**.

**[0058]** The docking station processor **910** can also perform resource downloading to the portable processor **720** (FIG. **7**) as part of the synchronous serial data **971**. That is, according to the invention, the docking station **660** provides functionality not present in the portable **610** (FIG. **6**), and, when docked, that added capability can be reflected by the portable user interface, i.e. the soft keys **870** (FIG. **8A**) and the display **740** (FIG. **8A**). For example, a portable **610** (FIG. **6**) providing only pulse oximetry measurements can be docked to a docking station **660** having the added functionality of blood pressure measurements. The docking station **660** can download a blood pressure measurement menu and an associated user interface to the portable **610** (FIG. **6**) upon docking, allowing the portable **610** (FIG. **6**) to control and display this additional docking station functionality. Docking station resource downloading would apply to other physiological measurements as well, such as respiration rate, EEG, ECG and EtCO<sub>2</sub> to name a few.

**[0059]** The docking station processor **910** accesses non-volatile memory **920** over a high-speed bus **922**. The non-volatile memory **920** is re-programmable and contains program data for the processor **910** including instrument communication protocols, synchronization information, a boot image, manufacturing history and diagnostic failure history.

**[0060]** The waveform generator **930** generates a synthesized waveform that a conventional pulse oximeter can process to calculate SpO<sub>2</sub> and pulse rate values or exception messages, as described above with respect to FIG. **4**. However, in the present embodiment, as explained above, the waveform generator output does not reflect a physiological waveform. It is merely a waveform constructed from stored memory data to cause the external pulse oximeter to calculate the correct saturation and pulse rate. In an alternative arrangement, physiological data could be scaled or otherwise mathematically converted and provided to the external pulse oximeter, but the external pulse oximeter would often not be able to calculate the proper saturation values, and the upgrading feature would be lost. This is particularly true due to the likely mismatch in the actual sensor wavelength and the calibration curves in the external pulse oximeter. The waveform generator **930** is enabled if an interface cable **690** (FIG. **6**), described below with respect to FIG. **10**, with valid synchronization information is connected. Otherwise, the power to the waveform generator **930** is disabled, thereby rendering the waveform generator inoperable.

**[0061]** The status indicators **982** are a set of LEDs on the front of the docking station **660** used to indicate various conditions including external power (AC), portable docked, portable battery charging, docking station battery charging and alarm. The serial data port **682** is used to interface with either a computer, a serial port of conventional pulse oximeters or serial printers via a standard RS-232 OB-9 connector **962**. This port **682** can output trend memory, SpO<sub>2</sub> and pulse rate and support the system protocols of various manufacturers. The analog output **688** is used to interface with analog input chart recorders via a connector **964** and can output "real-time" or trend SpO<sub>2</sub> and pulse rate data. The nurse call output **684** from a connector **964** is activated when alarm limits are exceeded for a predetermined number of consecutive seconds. In another embodiment, data, including alarms, could be routed to any number of communications ports, and even over the Internet, to permit remote use of the upgrading pulse oximeter.

**[0062]** The PROM interface **940** accesses synchronization data **692** from the PROM **1010** (FIG. **10**) in the interface cable **690** (FIGS. **6**, **10**) and provides synchronization status **942** to the docking station processor **910**. The portable interface **970** provides the interconnection to the portable **610** (FIG. **6**) through the docking station interface **760** (FIG. **7**).

**[0063]** As shown in FIG. **9**, external power **668** is provided to the docking station **660** through a standard AC connector **968** and on/off switch **969**. When the docking station **660** has external power **668**, the power supply **990** charges the battery in the portable power supply **730** (FIG. **7**) and the battery, if any, in the docking station power supply **990**. When the portable **610** (FIG. **6**) is either removed or turned off, the docking station power **973** is removed and the docking station **660** is turned off, except for the battery charger portion of the power supply **990**. The docking station power **973** and, hence, the docking station **660** powers on whenever a docked portable **610** (FIG. **6**) is switched on. The portable **610** (FIG. **6**) supplies power for an embodiment of the docking station **660** without a battery when external power **668** is removed or fails.

**[0064]** FIG. **10** provides further detail regarding the interface cable **690** used to connect between the docking station **660** (FIG. **6**) and the host instrument **260** (FIG. **2**). The interface cable **690** is configured to interface to a specific host instrument via the sensor input to the host instrument. A PROM **1010** built into the interface cable **690** contains information identifying a sensor type, a specific host instrument, and the calibration data (if necessary) of the specific host instrument. This PROM information can be read by the docking station **660** (FIG. **6**) as synchronization data **692**. Advantageously,

the synchronization data **692** allows the docking station **660** (FIG. 6) to generate a waveform to the host instrument that causes the host instrument to display SpO<sub>2</sub> values equivalent to those calculated by the portable **610** (FIG. 6). The interface cable **690** includes an LED drive path **672**. In the embodiment shown in FIG. 10, the LED drive path **672** is configured for common anode LEDs and includes IR cathode, red cathode and common anode signals. The interface cable **690** also includes a detector drive path **674**, including detector anode and detector cathode signals.

**[0065]** A menu option on the portable **610** (FIG. 6) also allows synchronization information to be calculated in the field. With manual synchronization, the docking station **660** (FIG. 6) generates a waveform to the host instrument **260** (FIG. 2) and displays an expected SpO<sub>2</sub> value. The user enters into the portable the SpO<sub>2</sub> value displayed on the host instrument using the portable keypad **750** (FIG. 7). These steps are repeated until a predetermined number of data points are entered and the SpO<sub>2</sub> values displayed by the portable and the host instrument are consistent.

**[0066]** FIGS. 11A-B depict an embodiment of the portable **610**, as described above with respect to FIG. 6. FIGS. 12A-B depict an embodiment of the docking station **660**, as described above with respect to FIG. 6. FIG. 13 depicts an embodiment of the UPO **210** where the portable **610** is docked with the docking station **660**, also as described above with respect to FIG. 6.

**[0067]** FIG. 11A depicts the portable front panel **1110**. The portable **610** has a patient cable connector **618**, as described above with respect to FIG. 6. Advantageously, the connector **618** is rotatably mounted so as to minimize stress on an attached patient cable (not shown). In one embodiment, the connector **618** can freely swivel between a plane parallel to the front panel **1110** and a plane parallel to the side panel **1130**. In another embodiment, the connector **618** can swivel between, and be releasably retained in, three semi-locked positions. The connector **618** can be rotated from a semi-locked position with moderate force. A first locked position is as shown, where the connector is in a plane parallel to the front panel **1110**. A second locked position is where the connector **618** is in a plane parallel to the side panel **1130**. The connector **618** also has an intermediate locked position 45° between the first and the second locked positions. The connector **618** is placed in the first locked position for attachment to the docking station **660**.

**[0068]** Shown in FIG. 11A, the portable front panel **1110** also has a speaker **772**, as described with respect to FIG. 7. Further, the front panel **1110** has a row of soft keys **870** and fixed keys **880**, as described above with respect to FIG. 8. In addition, the front panel **1110** has a finger actuated latch **1120** that locks onto a corresponding catch **1244** (FIG. 12A) in the docking station **660**, allowing the portable **610** to be releasably retained by the docking station **660**. An OEM label can be affixed to a recessed area **1112** on the front panel **1110**.

**[0069]** FIG. 11B depicts the portable back panel **1140**. The back panel **1140** has a socket **763**, a pole clamp mating surface **1160**, and a battery pack compartment **1170**. The socket **763** is configured to mate with a corresponding docking station plug **972** (FIG. 12A). The socket **763** and plug **972** (FIG. 12A) provide the electrical connection interface between the portable **610** and the docking station **660** (FIG. 12A). The socket **763** houses multiple spring contacts that compress against plated edge-connector portions of the docking station plug **972** (FIG. 12A). A conventional pole clamp (not shown) may be removably attached to the mating surface **1160**. This conveniently allows the portable **610** to be held to various patient-side or bedside mounts for hands-free pulse oximetry monitoring. The portable power supply **730** (FIG. 7) is contained within the battery pack compartment **1170**. The compartment **1170** has a removable cover **1172** for protection, insertion and removal of the portable battery pack. Product labels, such as a serial number identifying a particular portable, can be affixed with the back panel indent **1142**.

**[0070]** FIG. 12A depicts the front side **1210** of the docking station **660**. The front side **1210** has a docking compartment **1220**, a pole clamp recess **1230**, pivots **1242**, a catch **1244**, a plug connector **972** and LED status indicators **982**. The docking compartment **1220** accepts and retains the portable **610** (FIGS. 11A-B), as shown in FIG. 13. When the portable **610** (FIGS. 11A-B) is docked in the compartment **1220**, the pole clamp recess **1230** accommodates a pole clamp (not shown) attached to the portable's pole clamp mating surface **1160** (FIG. 11B), assuming the pole clamp is in its closed position. The portable **610** (FIGS. 11A-B) is retained in the compartment **1220** by pivots **1242** that fit into corresponding holes in the portable's side face **1130** and a catch **1244** that engages the portable's latch **1120** (FIG. 11A). Thus, the portable **610** (FIGS. 11A-B) is docked by first attaching it at one end to the pivots **1242**, then rotating it about the pivots **1242** into the compartment **1220**, where it is latched in place on the catch **1244**. The portable **610** (FIGS. 11A-B) is undocked in reverse order, by first pressing the latch **1120** (FIG. 11A), which releases the portable from the catch **1244**, rotating the portable **610** (FIGS. 11A-B) about the pivots **1242** out of the compartment **1220** and then removing it from the pivots **1242**. As the portable is rotated into the compartment, the docking station plug **972** inserts into the portable socket **763** (FIG. 11B), providing the electrical interface between the portable **610** and the docking station **660**. The status indicators **982** are as described above with respect to FIG. 9.

**[0071]** FIG. 12B depicts the back side **1260** of the docking station **660**. The back side **1260** has a serial (RS-232 or USB) connector **962**, an analog output and nurse call connector **964**, an upgrade port connector **966**, an AC power plug **968**, an on/off switch **969** and a ground lug **1162**. A handle **1180** is provided at one end and fan vents **1170** are provided at the opposite end. A pair of feet **1190** are visible near the back side **1260**. A corresponding pair of feet (not visible) are located near the front side **1210** (FIG. 12A). The feet near the front side **1210** extend so as to tilt the front side **1210** (FIG. 12A) upward, making the display **740** (FIG. 13) of a docked portable **610** (FIG. 13) easier to read.

[0072] FIG. 13 illustrates both the portable 610 and the docking station 660. The portable 610 and docking station 660 constitute three distinct pulse oximetry instruments. First, the portable 610 by itself, as depicted in FIGS. 11A-B, is a handheld pulse oximeter applicable to various patient monitoring tasks requiring battery power or significant mobility, such as ambulance and ER situations. Second, the portable 610 docked in the docking station 660, as depicted in FIG. 13, is a standalone pulse oximeter applicable to a wide-range of typical patient monitoring situations from hospital room to the operating room. Third, the portable 610 docked and the upgrade port 966 (FIG. 12B) connected with an interface cable to the sensor port of a conventional pulse oximeter module 260 (FIG. 2) within a multiparameter patient monitoring instrument 250 (FIG. 2) or other conventional pulse oximeter, is a universal/upgrading pulse oximeter (UPO) instrument 210, as described herein. Thus, the portable 610 and docking station 660 configuration of the UPO 210 advantageously provides a three-in-one pulse oximetry instrument functionality.

[0073] Another embodiment of the docking station 660 incorporates an input port that connects to a blood pressure sensor and an output port that connects to the blood pressure sensor port of a multiparameter patient monitoring system (MPMS). The docking station 660 incorporates a signal processor that computes a blood pressure measurement based upon an input from the blood pressure sensor. The docking station 660 also incorporates a waveform generator connected to the output port that produces a synthesized waveform based upon the computed measurement. The waveform generator output is adjustable so that the blood pressure value displayed on the MPMS is equivalent to the computed blood pressure measurement. Further, when the portable 610 is docked in the docking station 660 and the blood pressure sensor is connected to the input port, the portable displays a blood pressure value according to the computed blood pressure measurement. Thus, in this embodiment, the docking station 660 provides universal/upgrading capability for both blood pressure and SpO<sub>2</sub>.

[0074] Likewise, the docking station 660 can function as an universal/upgrading instrument for other vital sign measurements, such as respiratory rate, EKG or EEG. For this embodiment, the docking station 660 incorporates related sensor connectors and associated sensor signal processors and upgrade connectors to an MPMS or standalone instrument. In this manner, a variety of vital sign measurements can be incorporated into the docking station 660, either individually or in combination, with or without SpO<sub>2</sub> as a measurement parameter, and with or without the portable 610. In yet another embodiment, the docking station 660 can be configured as a simple SpO<sub>2</sub> upgrade box, incorporating a SpO<sub>2</sub> processor and patient cable connector for an SpO<sub>2</sub> sensor that functions with or without the portable 610.

[0075] Unlike a conventional standalone pulse oximeter, the standalone configuration shown in FIG. 13 has a rotatable display 740 that allows the instrument to be operated in either a vertical or horizontal orientation. A tilt sensor 950 (FIG. 9) indicates when the bottom face 1310 is placed along a horizontal surface or is otherwise horizontally-oriented. In this horizontal orientation, the display 740 appears in landscape mode (FIG. 8C). The tilt sensor 950 (FIG. 9) also indicates when the side face 1320 is placed along a horizontal surface or is otherwise horizontally oriented. In this vertical orientation, the display 740 appears in portrait mode (FIG. 8B). A soft key 870 on the portable 610 can override the tilt sensor, allowing the display to be presented at any 90° orientation, i.e. portrait, landscape, "upside-down" portrait or "upside-down" landscape orientations. The handheld configuration (FIG. 11A), can also present the display 740 at any 90° orientation using a soft key 870. In the particular embodiment described above, however, the portable 610 does not have a separate tilt sensor and, hence, relies on a soft key 870 to change the orientation of the display when not docked.

[0076] FIG. 14 illustrates the docking station 660 incorporated within a local area network (LAN). The LAN shown is Ethernet-based 1460, using a central LAN server 1420 to interconnect various LAN clients 1430 and other system resources such as printers and storage (not shown). In this embodiment, an Ethernet controller module 1410 is incorporated with the docking station 660. The controller module 1410 can be incorporated within the docking station 660 housing or constructed as an external unit. In this manner, the UPO, according to the present invention, can communicate with other devices on the LAN or over the Internet 1490.

[0077] The Ethernet controller module 1410 can be embedded with web server firmware, such as the Hewlett-Packard (HP) BFOOT-10501. The module 1410 has both a 10 Base-T Ethernet interface for connection to the Ethernet 1460 and a serial interface, such as RS-232 or USB, for connection to the docking station 660. The module firmware incorporates HTTP and TCP/IP protocols for standard communications over the World Wide Web. The firmware also incorporates a micro web server that allows custom web pages to be served to remote clients over the Internet, for example. Custom C++ programming allows expanded capabilities such as data reduction, event detection and dynamic web page configuration.

[0078] As shown in FIG. 14, there are many applications for the docking station 660 to Ethernet interface. Multiple UPOs can be connected to a hospital's LAN, and a computer on the LAN could be utilized to upload pulse rate and saturation data from the various UPOs, displaying the results. Thus, this Ethernet interface could be used to implement a central pulse oximetry monitoring station within a hospital. Further, multiple UPOs from anywhere in the world can be monitored from a central location via the Internet. Each UPO is addressable as an individual web site and downloads web pages viewable on a standard browser, the web pages displaying oxygen saturation, pulse rate and related physiological measurements from the UPO. This feature allows a caregiver to monitor a patient regardless of where the patient or caregiver is located. For example a caregiver located at home in one city or at a particular hospital could

download measurements from a patient located at home in a different city or at the same or a different hospital. Other applications include troubleshooting newly installed UPOs or uploading software patches or upgrades to UPOs via the Internet. In addition alarms could be forwarded to the URL of the clinician monitoring the patient.

5 [0079] The UPO may have other configurations besides the handheld unit described in connection with FIG. 5 or the portable 610 and docking station 660 combination described in connection with FIGS. 11-13. The UPO may be a module, with or without a display, that can be removably fastened to a patient via an arm strap, necklace or similar means. In a smaller embodiment, this UPO module may be integrated into a cable or connector used for attaching a sensor to a pulse oximeter. The UPO may also be a circuit card or module that can externally or internally plug into or mate with a standalone pulse oximeter or multiparameter patient monitoring system. Alternatively, the UPO may be configured as  
10 a simple standalone upgrade instrument.

[0080] FIG. 15 illustrates a UPO configuration utilizing a patient care bed 1500. The bed 1500 includes a bed frame and mattress 1502, lower rails 1506 and upper rails 1508. One of the upper rails 1508 incorporates an instrument panel 1510 and the docking station 1540 is incorporated into the instrument panel 1510. The instrument panel 1510 typically has keypad controls 1520, a display 1530, and a power supply 1550. The power supply 1550 has a power cord 1552 that plugs into an AC power source. The docking station 1540 includes a docking station compartment that accepts and electrically connects to the portable 610. In this manner, UPO can monitor a patient as a portable 610 during transport and then dock at the patient's destination as an integral part of the bedside instrument panel 1510.

15 [0081] FIG. 16 is block diagram of the instrument panel 1510 and incorporated docking station 1540. The instrument panel 1510 has a processor 1694, which, in conjunction with a display driver 1696 and a keypad interface 1697, drives the display 1530 and receives commands from the keypad controls 1520. The processor 1694 also communicates with a docked portable 610 (FIG. 6) via the docking station interface 1691 and a portable connector 1610 within the docking station receptacle. In one embodiment, the docking station 1540 simply provides a communications path and a DC power path between the docked portable 610 (FIG. 6) and the instrument panel 1510 via the portable connector 1610 and the docking station interface 1690. In that embodiment, the portable management processor 720 (FIG. 7) is programmed with the communications protocol of the instrument panel processor 1694. In another embodiment, the docking station 1540 provides communications and upgrade capability in a manner similar to that shown in FIG. 9. In that embodiment, the bed-integrated UPO could also connect to and upgrade a MPMS pulse oximeter module 260 (FIG. 2) or other external pulse oximeter located near the patient bed 1500, in a manner as described with respect to FIG. 2, above.

20 [0082] Although a universal/upgrading apparatus and method have been mainly described in terms of a pulse oximetry measurement embodiment, the present invention is equally applicable to other physiological measurement parameters such as blood pressure, respiration rate, EEG, ECG and EtCO<sub>2</sub> (capnography) to name a few. In addition, a universal/upgrading instrument having a single physiological measurement parameter or a multiple measurement parameter capability and configured as a handheld, standalone, portable, docking station, module, plug-in, circuit card, to name a few, is also within the scope of the present invention.

25 [0083] FIGS. 17A-B illustrate one embodiment of a dual-mode pulse oximeter module according to the present invention. As shown in FIG. 17A, a dual-mode pulse oximeter module 1700 is contained within a case 1710 having dimensions that conform to a multiparameter patient monitoring system (MPMS) slot 290 (FIG. 2). The dual-mode module 1700 has a display 1720, a keypad 1730, and a patient cable connector 1740. A module connector 1750 (FIG. 17B) mates and electrically connects with a corresponding backplane connector (not shown) within an MPMS slot 292 (FIG. 2).

30 [0084] In reference to FIGS. 17A-B, the dual-mode pulse oximeter module 1700 has a portable mode, separate from MPMS 250 (FIG. 2), and an integrated mode, plugged into an MPMS slot 292 (FIG. 2). In the portable mode, the pulse oximeter module 1700 functions as a handheld or standalone pulse oximeter, in a manner similar to that described with respect to FIG. 6, above. Specifically, the portable module 1700 is a battery-powered, pulse oximeter instrument. The portable module 1700 connects to a sensor through a patient cable attached to the patient cable connector 1740. The module 1700 provides the sensor with a drive signal that alternately activates the sensor's red and IR LEDs, as is well-known in the art. The pulse oximeter module 1700 also receives a corresponding photo-plethysmographic detector signal from the sensor, also well-known in the art. The portable module 1700 processes this sensor signal to derive oxygen saturation and pulse rate measurements. In the portable mode, this information is provided on the module display 1720, and a keypad 1730 provides a user interface for operational control of the portable module 1700.

35 [0085] Also in reference to FIGS. 17A-B, in the integrated mode, the pulse oximeter module 1700 is a plug-in module that functions in conjunction with the MPMS 250 (FIG. 2). When installed in a MPMS slot 290 (FIG. 2), the integrated module 1700 receives power from the MPMS 250 (FIG. 2), drives a sensor, receives a corresponding photo-plethysmographic sensor signal, and processes this sensor signal to derive oxygen saturation and pulse rate measurements, as described with respect to the portable mode, above. The integrated module 1700, however, communicates oxygen saturation, pulse rate and related measurements to the MPMS 250 (FIG. 2) via the module connector 1750. Typically, the integrated module display 1720 and keypad 1730 are disabled, and the MPMS monitor 280 (FIG. 2) displays the physiological measurements made by the integrated module 1700.

40 [0086] FIG. 18 is a block diagram of the dual-mode pulse oximeter module 1700. The pulse oximeter module 1700

includes a pulse oximeter processor **1810**, management processor **1820**, power supply **1830**, power manager **1840**, keypad interface **1850**, speaker driver **1860**, display driver **1870**, clock **1802**, watch dog timer **1804**, and MPMS interface **1880**. These components function in a manner similar to that described with respect to FIG. 7, above. Specifically, the pulse oximeter processor **1810** functions as an internal pulse oximeter, interfacing the pulse oximeter module **1700** to a sensor and deriving oxygen saturation, pulse rate, a plethysmograph and a pulse indicator.

**[0087]** As shown in FIG. 18, the management processor **1820** controls the various functions of the pulse oximeter module **1700**, including data communications with the pulse oximeter processor **1810** and communications with the MPMS **250** via the MPMS interface **1880**. The physical connection to the MPMS **250** is via the module connector **1750** (FIG. 17B) and a corresponding MPMS backplane connector. The electrical connection is via a module interface 1898. The management processor **1820** utilizes a real-time clock **1802** to keep the current date and time, which includes time and date information that is stored in nonvolatile memory **1806** along with oxygen saturation related parameters to create trend data. The management processor **1820** also controls a user interface by transferring data to a display driver **1870** and from a keypad interface **1850**. The management processor **1820** generates various alarm signals, which control a speaker driver **1860**. The management processor **1820** also monitors system status, which includes battery status, indicating battery levels, and plug-in status, indicating whether the pulse oximeter module **1700** is connected to the MPMS **250**. Another task of the management processor **1820** includes maintenance of a watchdog function. A watchdog **1804** monitors processor status on the watchdog data input and asserts a management processor reset if a fault is detected, along with audible and visual alarms.

**[0088]** Also shown in FIG. 18, the pulse oximeter module **1700** gets its power from batteries in the power supply **1830** or from power supplied on line **1884** from the MPMS **250** via the MPMS interface **1880**. A power manager **1840** monitors the keypad on/off switch via the keypad interface **1850** and turns-on module power **1830** accordingly. The power manager **1840** turns off module power **1830** on command by the management processor **1820**. DC/DC converters within the power supply **1830** generate the required voltages for module operation. A battery charger within the module power supply **1830** provides charging current to recharge the internal batteries. A non-volatile memory **1806** is connected to the management processor **1820** and used to store boot data, alarm limits trend data and program data.

**[0089]** FIG. 19 illustrates another embodiment of a dual-mode pulse oximeter according to the present invention. A docking station module **1900** has a docking portion **1910** and a plug-in portion **1920**. The docking portion **1910** has a docking compartment **1930** and a portable socket **1940**. The docking compartment **1930** is configured to accept and retain a portable pulse oximeter **610**, such as described with respect to FIGS. 6 and 11A-B, above. In particular, the portable **610** has a socket **763** (FIG. 11B) that mates with a corresponding plug **1940**, providing an electrical connection between the portable pulse oximeter **610** and the docking station module **1900**. The plug-in portion **1920** has dimensions that conform to an MPMS slot **290** (FIG. 2). A module connector similar to that of the pulse oximeter module connector **1750** (FIG. 17B) mates and electrically connects with a corresponding backplane connector (not shown) within an MPMS slot **290** (FIG. 2).

**[0090]** In reference to FIG. 19, the docking station module **1900** allows the portable **610** to function as a dual-mode pulse oximeter. That is, the portable **610** has a portable mode separate from the MPMS **250** (FIG. 2) and an integrated mode connected to an MPMS slot **290** (FIG. 2) via the docking station module **1900**. In this manner, the portable **610** functions much as the dual-mode module **1700** (FIGS. 17A-B) described with respect to FIGS. 17A-B, above. In the portable mode, the portable **610** functions as a handheld or standalone pulse oximeter as described with respect to FIG. 6, above. In the integrated mode, the portable **610** is docked to the docking station module **1900** and functions in conjunction with the MPMS **250** (FIG. 2). When installed in an MPMS slot **290** (FIG. 2), the portable receives power from a MPMS **250** (FIG. 2), drives a sensor, receives a corresponding photo-plethysmographic sensor signal, and processes this sensor signal to derive oxygen saturation and pulse rate measurements, as described with respect to FIG. 6, above. The integrated portable **610**, however, communicates oxygen saturation, pulse rate and related measurements to the MPMS **250** (FIG. 2) via the docking station module **1900**, as described below. Typically, the portable display **740** and keys **750** are disabled, and the MPMS monitor **280** (FIG. 2) controls and displays the physiological measurements made by the integrated portable **610**.

**[0091]** Also in reference to FIG. 19, in an alternative embodiment, the docking compartment **1930** is configured to accept and retain a pulse oximeter module **1700** (FIGS. 17A-B). In that embodiment, the docking compartment **1930** has a docking connector (not shown) that mates with the module connector **1750** (FIG. 17B), providing an electrical connection between the pulse oximeter module **1700** (FIGS. 17A-B) and the docking station module **1900**.

**[0092]** FIG. 20 illustrates the docking station module **1900** attached to the MPMS **250**. The plug-in portion **1920** (FIG. 19) plugs into at least one of the MPMS slots **290** (FIG. 2) and electrically connects to the MPMS backplane as described with respect to FIG. 19, above. In the portable mode (shown), the portable pulse oximeter **610** functions in a manner similar to the portable module **1700** (FIGS. 17A-B), i.e. as handheld or standalone pulse oximeter. In the integrated mode, the portable **610** is installed into the docking compartment **1930**, providing an electrical connection and communications interface between the MPMS **250** and the portable pulse oximeter **610**. In the integrated mode, the combination of the portable pulse oximeter **610** and the docking station module **1900** functions in a manner similar to the integrated

module **1700** (FIGS. **17A-B**).

**[0093]** FIG. **21** is a block diagram of a pass-through embodiment of a docking station module **1900**, which includes a portable connector **2110**, an MPMS connector **2160** and a direct electrical path between the two connectors **2110**, **2160**. In this embodiment, the docking station module **1900** simply provides a physical interface between the portable **610** (FIG. **20**) and the MPMS **250**. A MPMS communications path **1882** is directly routed to the portable communications path **2112**. MPMS power **1884** is also directly routed to the portable input power line **2114**. The docking station module **1900**, with various configurations of the plug-in portion **1920** (FIG. **19**) and associated module connector can be adapted to the slots **290** (FIG. **2**) of various MPMS manufacturer. In this manner, the docking station module **1900** can function as a universal interface between the portable pulse oximeter **610** or, alternatively, the pulse oximeter module **1700** and various multiparameter patient monitoring systems.

**[0094]** FIG. **22** is a block diagram of another embodiment of a docking station module **1900a**, which includes a portable interface **2210**, docking station processor **2220**, power supply **2230** and monitor interface **2260**. These components function in a manner similar to that described with respect to FIG. **9**, above. Specifically, the docking station processor **2220** orchestrates the activity of the docking station module **1900**. The processor **2220** provides synchronous serial data for communications with the portable **610** (FIG. **6**) and sends watchdog messages to the portable processor **720** (FIG. **7**) as part of the synchronous serial data to ensure the correct operation of the docking station processor **2220**. The docking station processor **2220** accesses non-volatile, re-programmable memory **2206** over a high-speed bus to obtain program data for the processor **2220**. In one embodiment, the status display **2240** is a set of LEDs on the front of the docking station module **1900** used to indicate various conditions including portable docked, portable battery charging and alarm. The portable interface **2210** interconnects with the docking station interface **760** (FIG. **7**) of the portable **610** (FIG. **6**). External power **1884** is provided to the docking station module **1900a** from the MPMS **250**. The docking station power supply **2230** charges the battery in the portable power supply **730** (FIG. **7**). When the portable **610** (FIG. **6**) is either removed or turned off, the docking station power **2232** is removed and the docking station **1900** is turned off, except for the battery charger portion of the power supply **2230**. The docking station power **2232** and, hence, the docking station **1900** turns on whenever a docked portable **610** (FIG. **6**) is turned on.

**[0095]** Although the dual-mode physiological measuring apparatus and method of the present invention is described in detail with respect to pulse oximetry measurements, one of ordinary skill in the art will recognize that a dual-mode MPMS plug-in module or a portable apparatus that docks to a MPMS plug-in docking station module could incorporate physiological measurement capabilities other than or in addition to pulse oximetry, such as blood pressure, respiration rate, EEG, ECG and EtCO<sub>2</sub> (capnography) to name a few.

**[0096]** The dual-mode pulse oximeter has been disclosed in detail in connection with various embodiments of the present invention. These embodiments are disclosed by way of examples only and are not to limit the scope of the present invention, which is defined by the claims that follow. One of ordinary skill in the art will appreciate many variations and modifications within the scope of this invention.

## Claims

### 1. A patient monitoring system comprising:

a portable physiological measurement device (**610**) comprising a first local display and capable of operating in a portable mode, said portable mode providing portable monitoring of one or more physiological parameters of a patient through communication with one or more sensors, and capable of operating in an integrated mode, said integrated mode providing integrated monitoring of said one or more physiological parameters of a patient; and

a docking station (**660**), said docking station configured to mate with the portable physiological measurement device when the portable physiological measurement device is operating in at least the integrated mode, wherein the portable physiological measurement device is in electrical communication with the docking station, and further wherein the docking station is configured to provide additional functionality to the portable physiological measurement device, said additional functionality comprising the measurement of at least one additional physiological parameter, and further wherein the docking station is in electrical communication with a second local display.

### 2. The patient monitoring system of Claim 1, wherein the portable physiological measurement device further comprises a management processor.

### 3. The patient monitoring system of Claim 2, wherein the management processor is adapted to generate an output usable by said patient monitoring system to cause to be displayed at least one of the monitored one or more

physiological parameters of the patient when the portable physiological measurement device is operating in at least the integrated mode.

- 5 4. The patient monitoring system of Claim 3, wherein the patient monitoring system is adapted to communicate with a display device.
5. The patient monitoring system of Claim 1, wherein the docking station comprises the second local display.
- 10 6. The patient monitoring system of Claim 1, wherein the one or more physiological parameters comprises one or more of blood oxygen content, respiratory gas, blood pressure, ECG, and pulse rate.
7. The patient monitoring system of Claim 1, wherein the docking station and the portable physiological measurement device are electrically connected.
- 15 8. A patient monitoring method utilizing a portable measurement apparatus comprising the steps of:
  - performing as first physiological measurement with a portable measurement apparatus physically and electrically isolated from a docking station, said portable measurement apparatus and said docking station forming a patient monitoring system, wherein, said docking station is configured to mate with the portable measurement apparatus when the portable physiological measurement apparatus is operating in at least an integrated mode, wherein the portable physiological measurement device is in electrical communication with the docking station, wherein the portable measurement apparatus is configured to perform additional functions when said portable measurement apparatus is disclosed with said docking station, said additional functions comprising the measurement of at least one additional physiological parameter, and further wherein the docking station is in electrical communication with a second local display
  - 20 presenting information related to said first measurement on a display portion of said portable measurement apparatus;
  - performing a second physiological measurement with said portable measurement apparatus mated with said docking station;
  - 25 communicating said second physiological measurement to said docking station; and
  - presenting information related to said second measurement on a monitor in communication with said docking station.
- 35 9. The method of Claim 8, further comprising presenting information related to said first measurement on a monitor in communication with said docking station when said portable physiological measurement apparatus is mated with said docking station.
- 40 10. The method of Claim 8, wherein the physiological measurement comprises a measurement of one or more of blood oxygen content, respiratory gas, blood pressure, ECG, and pulse rate.
11. The patient monitoring system of Claim 1 or the method of claim 8, wherein the at least one physiological parameter comprises one or more of blood pressure, respiration rate, EEG, ECG and EtCO<sub>2</sub>.

#### 45 Patentansprüche

1. Patientenüberwachungssystem mit:

50 einer tragbaren physiologischen Meßvorrichtung (610), die eine erste lokale Anzeige aufweist und in einem tragbaren Modus arbeiten kann, wobei der tragbare Modus für tragbare Überwachung eines oder mehrerer physiologischer Parameter eines Patienten durch Kommunikation mit einem oder mehreren Sensoren sorgt, sowie in einem integrierten Modus arbeiten kann, wobei der integrierte Modus für integrierte Überwachung des einen oder der mehreren physiologischen Parameter eines Patienten sorgt; und

55 einer Docking-Station (660), wobei die Docking-Station so konfiguriert ist, daß sie sich mit der tragbaren physiologischen Meßvorrichtung verbindet, wenn die tragbare physiologische Meßvorrichtung mindestens im integrierten Modus arbeitet, wobei die tragbare physiologische Meßvorrichtung in elektrischer Kommunikation mit der Docking-Station steht, und wobei ferner die Docking-Station so konfiguriert ist, daß sie der tragbaren physiologischen Meßvorrichtung zusätzliche Funktionalität verleiht, wobei die zusätzliche Funktionalität die

## EP 1 309 270 B1

Messung mindestens eines weiteren physiologischen Parameters aufweist, und wobei ferner die Docking-Station in elektrischer Kommunikation mit einer zweiten lokalen Anzeige steht.

- 5 2. Patientenüberwachungssystem nach Anspruch 1, wobei die tragbare physiologische Meßvorrichtung ferner einen Leitprozessor aufweist.
- 10 3. Patientenüberwachungssystem nach Anspruch 2, wobei der Leitprozessor geeignet ist, eine durch das Patientenüberwachungssystem verwendbare Ausgabe zu erzeugen, um zu veranlassen, daß mindestens einer des einen oder der mehreren überwachten physiologischen Parameter des Patienten angezeigt wird, wenn die tragbare physiologische Meßvorrichtung mindestens im integrierten Modus arbeitet.
- 15 4. Patientenüberwachungssystem nach Anspruch 3, wobei das Patientenüberwachungssystem geeignet ist, mit einer Anzeigevorrichtung zu kommunizieren.
- 20 5. Patientenüberwachungssystem nach Anspruch 1, wobei die Docking-Station die zweite lokale Anzeige aufweist.
6. Patientenüberwachungssystem nach Anspruch 1, wobei der eine oder die mehreren physiologischen Parameter Blutsauerstoffgehalt, Atemgas, Blutdruck, EKG und/oder Pulsfrequenz aufweisen.
7. Patientenüberwachungssystem nach Anspruch 1, wobei die Docking-Station und die tragbare physiologische Meßvorrichtung elektrisch verbunden sind.
8. Patientenüberwachungsverfahren unter Nutzung einer tragbaren Meßvorrichtung mit den Schritten:
  - 25 Durchführen einer ersten physiologischen Messung mit einer tragbaren Meßvorrichtung, die von einer Docking-Station physisch und elektrisch isoliert ist, wobei die tragbare Meßvorrichtung und die Docking-Station ein Patientenüberwachungssystem bilden, wobei die Docking-Station so konfiguriert ist, daß sie sich mit der tragbaren Meßvorrichtung verbindet, wenn die tragbare physiologische Meßvorrichtung mindestens in einem integrierten Modus arbeitet, wobei die tragbare physiologische Meßvorrichtung in elektrischer Kommunikation mit der Docking-Station steht, wobei die tragbare Meßvorrichtung so konfiguriert ist, daß sie zusätzliche Funktionen durchführt, wenn die tragbare Meßvorrichtung an die Docking-Station angedockt ist, wobei die zusätzlichen Funktionen die Messung mindestens eines weiteren physiologischen Parameters aufweisen, und wobei ferner die Docking-Station in elektrischer Kommunikation mit einer zweiten lokalen Anzeige steht;  
30 Darstellen von Informationen, die sich auf die erste Messung beziehen, auf einem Anzeigeabschnitt der tragbaren Meßvorrichtung;  
35 Durchführen einer zweiten physiologischen Messung mit der tragbaren Meßvorrichtung, wobei sie mit der Docking-Station verbunden ist;  
Übertragen der zweiten physiologischen Messung zur Docking-Station; und  
40 Darstellen von Informationen, die sich auf die zweite Messung beziehen, auf einem Monitor, der in Kommunikation mit der Docking-Station steht.
  9. Verfahren nach Anspruch 8, ferner mit Darstellen von Informationen, die sich auf die erste Messung beziehen, auf einem Monitor, der in Kommunikation mit der Docking-Station steht, wenn die tragbare physiologische Meßvorrichtung mit der Docking-Station verbunden ist.
  - 45 10. Verfahren nach Anspruch 8, wobei die physiologische Messung eine Messung von Blutsauerstoffgehalt, Atemgas, Blutdruck, EKG und/oder Pulsfrequenz aufweist.
  - 50 11. Patientenüberwachungssystem nach Anspruch 1 oder Verfahren nach Anspruch 8, wobei der mindestens eine weitere physiologische Parameter Blutdruck, Atemfrequenz, EEG, EKG und/oder endexpiratorische CO<sub>2</sub>-Konzentration aufweist.

### Revendications

- 55 1. Système de surveillance de patient comprenant :

un dispositif de mesure physiologique portable (610) comprenant un premier afficheur local et capable de

- fonctionner dans un mode portable, ledit mode portable permettant une surveillance portable d'un ou de plusieurs paramètres physiologiques d'un patient par une communication avec un ou plusieurs capteurs, et capable de fonctionner dans un mode intégré, ledit mode intégré permettant une surveillance intégrée desdits un ou plusieurs paramètres physiologiques d'un patient ; et
- 5 une station d'accueil (660), ladite station d'accueil étant configurée pour s'accoupler avec le dispositif de mesure physiologique portable lorsque le dispositif de mesure physiologique portable fonctionne au moins dans le mode intégré, dans lequel le dispositif de mesure physiologique portable est en communication électrique avec la station d'accueil, et
- 10 en outre dans lequel la station d'accueil est configurée pour fournir une fonctionnalité supplémentaire au dispositif de mesure physiologique portable, ladite fonctionnalité supplémentaire comprenant la mesure d'au moins un autre paramètre physiologique, et en outre dans lequel la station d'accueil est en communication électrique avec un deuxième afficheur local.
- 15 **2.** Système de surveillance de patient selon la revendication 1, dans lequel le dispositif de mesure physiologique portable comprend en outre un processeur de gestion.
- 3.** Système de surveillance de patient selon la revendication 2, dans lequel le processeur de gestion est adapté pour générer une sortie utilisable par ledit système de surveillance de patient pour provoquer l'affichage d'au moins l'un
- 20 desdits un ou plusieurs paramètres physiologiques surveillés du patient lorsque le dispositif de mesure physiologique portable fonctionne au moins dans le mode intégré.
- 4.** Système de surveillance de patient selon la revendication 3, dans lequel le système de surveillance de patient est adapté pour communiquer avec un dispositif d'affichage.
- 25 **5.** Système de surveillance de patient selon la revendication 1, dans lequel la station d'accueil comprend le deuxième afficheur local.
- 6.** Système de surveillance de patient selon la revendication 1, dans lequel lesdits un ou plusieurs paramètres physiologiques comprennent un ou plusieurs de la teneur en oxygène du sang, du gaz respiratoire, de la tension artérielle, de l'ECG et du rythme cardiaque.
- 30 **7.** Système de surveillance de patient selon la revendication 1, dans lequel la station d'accueil et le dispositif de mesure physiologique portable sont connectés électriquement.
- 35 **8.** Procédé de surveillance de patient utilisant un dispositif de mesure portable comprenant les étapes consistant à :
- effectuer une première mesure physiologique avec un dispositif de mesure portable isolé physiquement et électriquement d'une station d'accueil, ledit dispositif de mesure portable et ladite station d'accueil formant un
- 40 système de surveillance de patient, dans lequel ladite station d'accueil est configurée pour s'accoupler avec le dispositif de mesure portable lorsque le dispositif de mesure physiologique portable fonctionne au moins dans un mode intégré, dans lequel le dispositif de mesure physiologique portable est en communication électrique avec la station d'accueil, dans lequel le dispositif de mesure portable est configuré pour mettre en oeuvre des fonctions supplémentaires lorsque ledit dispositif de mesure portable est branché à ladite station d'accueil,
- 45 lesdites fonctions supplémentaires comprenant la mesure d'au moins un autre paramètre physiologique, et en outre dans lequel la station d'accueil est en communication électrique avec un deuxième afficheur local ; présenter les informations associées à ladite première mesure sur une partie d'affichage dudit dispositif de mesure portable ;
- effectuer une deuxième mesure physiologique avec ledit dispositif de mesure portable accouplé à ladite station
- 50 d'accueil ; communiquer ladite deuxième mesure physiologique à ladite station d'accueil ; et présenter les informations associées à ladite deuxième mesure sur un moniteur en communication avec ladite station d'accueil.
- 55 **9.** Procédé selon la revendication 8, comprenant en outre la présentation des informations associées à ladite première mesure sur un moniteur en communication avec ladite station d'accueil lorsque ledit dispositif de mesure physiologique portable est accouplé à ladite station d'accueil.

## EP 1 309 270 B1

10. Procédé selon la revendication 8, dans lequel la mesure physiologique comprend une mesure d'un ou de plusieurs de la teneur en oxygène du sang, du gaz respiratoire, de la tension artérielle, de l'ECG et du rythme cardiaque.
11. Système de surveillance de patient selon la revendication 1 ou procédé selon la revendication 8, dans lequel ledit au moins un autre paramètre physiologique comprend un ou plusieurs de la tension artérielle, du rythme respiratoire, de l'EEG, de l'ECG et de l'EtCO<sub>2</sub>.

5

10

15

20

25

30

35

40

45

50

55

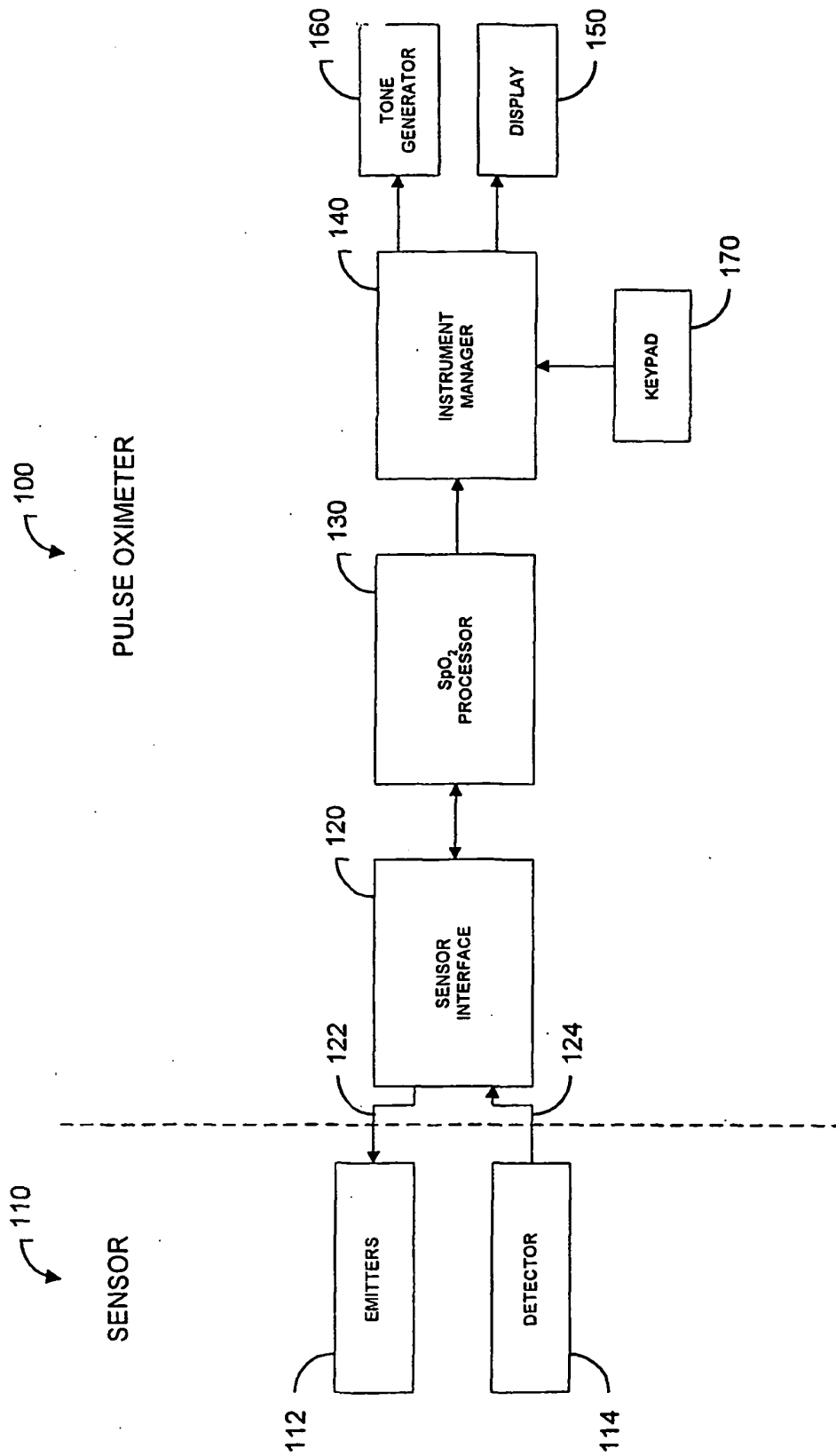

FIG. 1 (prior art)

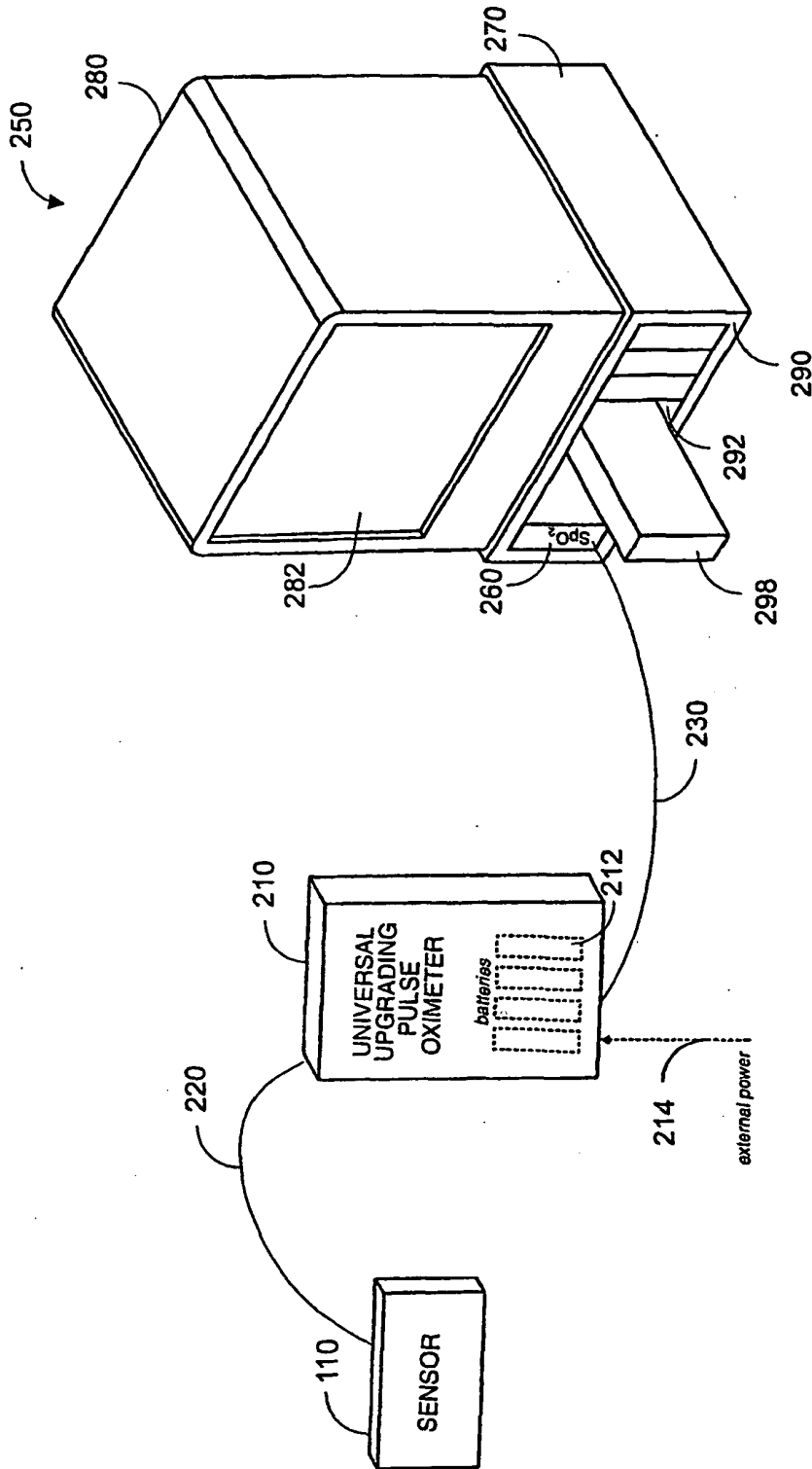

FIG. 2

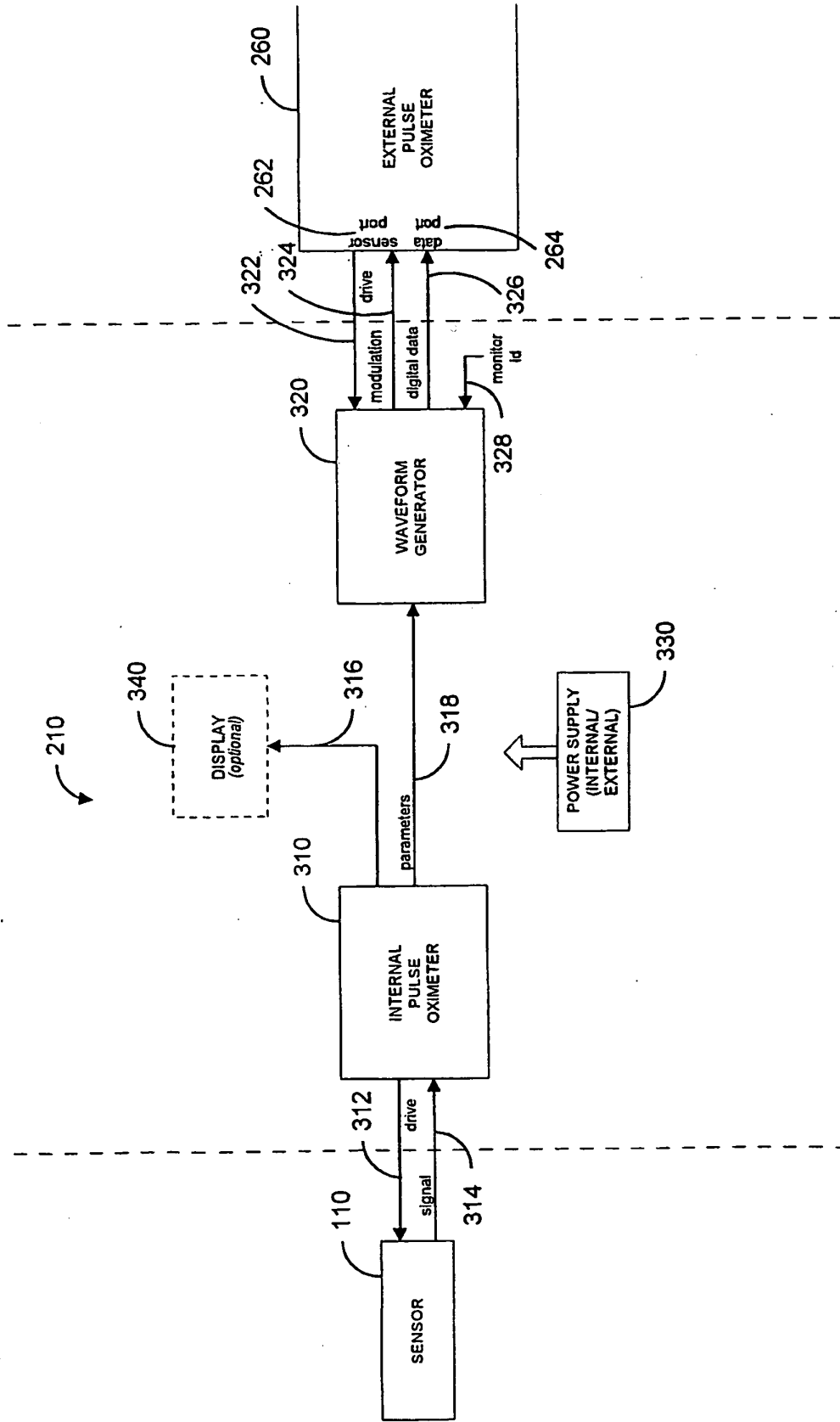

FIG. 3

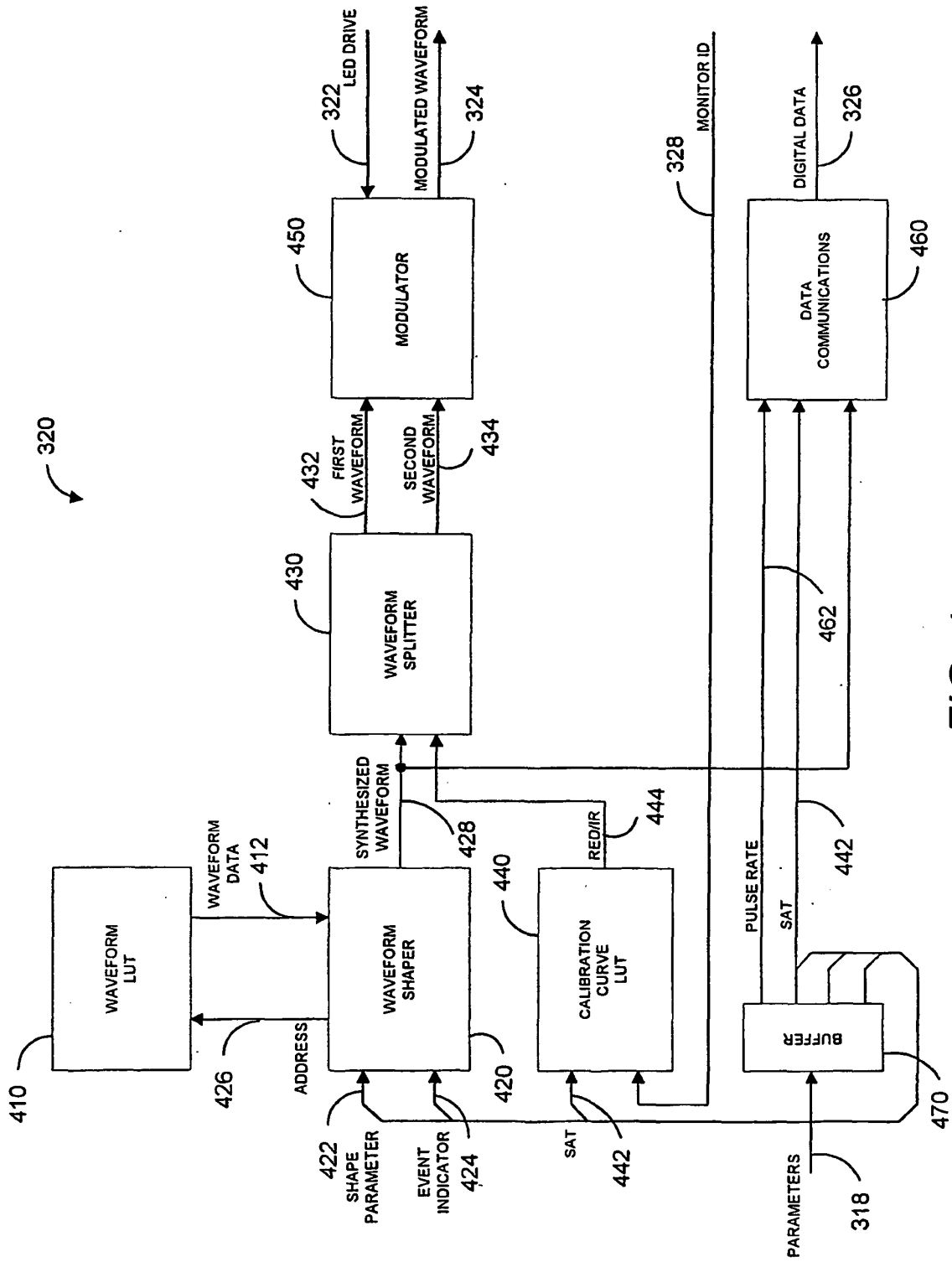

FIG. 4

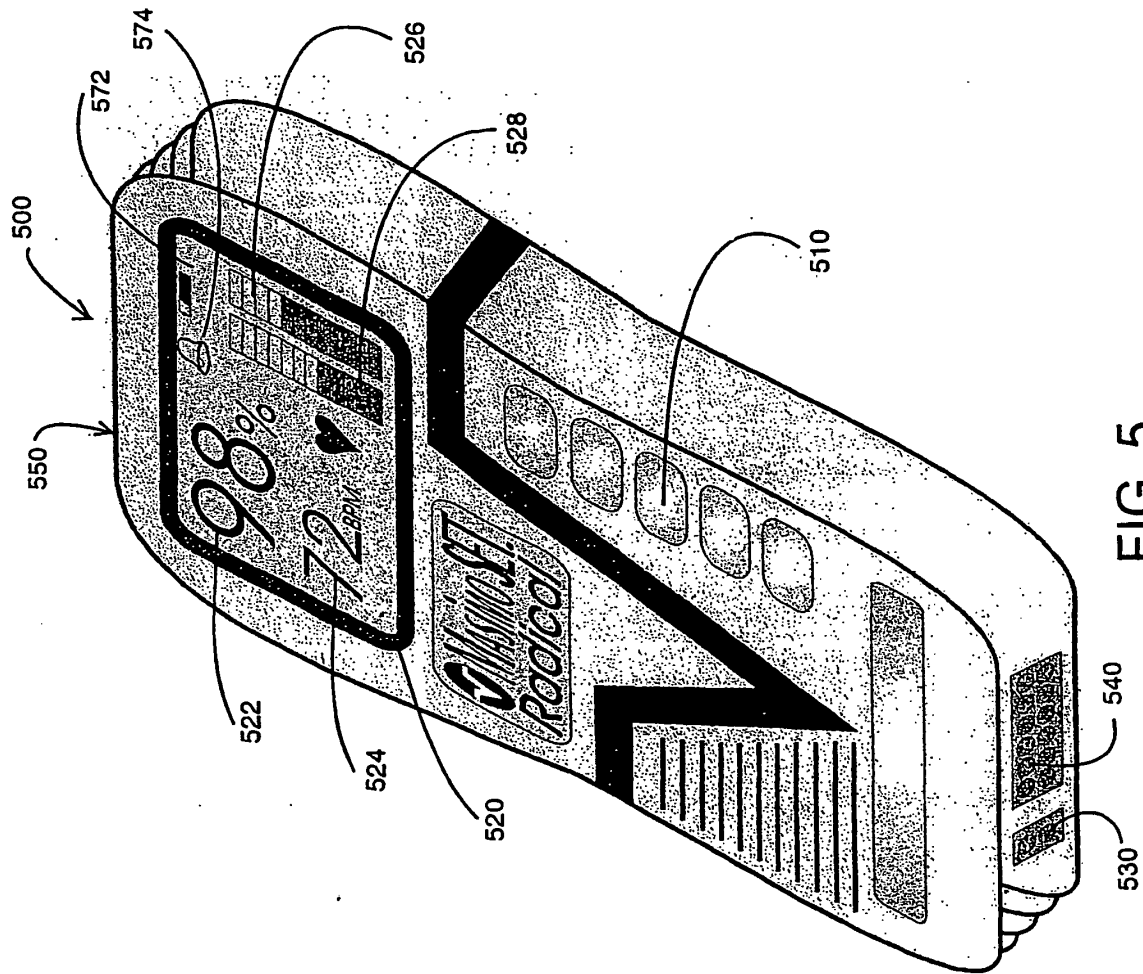

FIG. 5

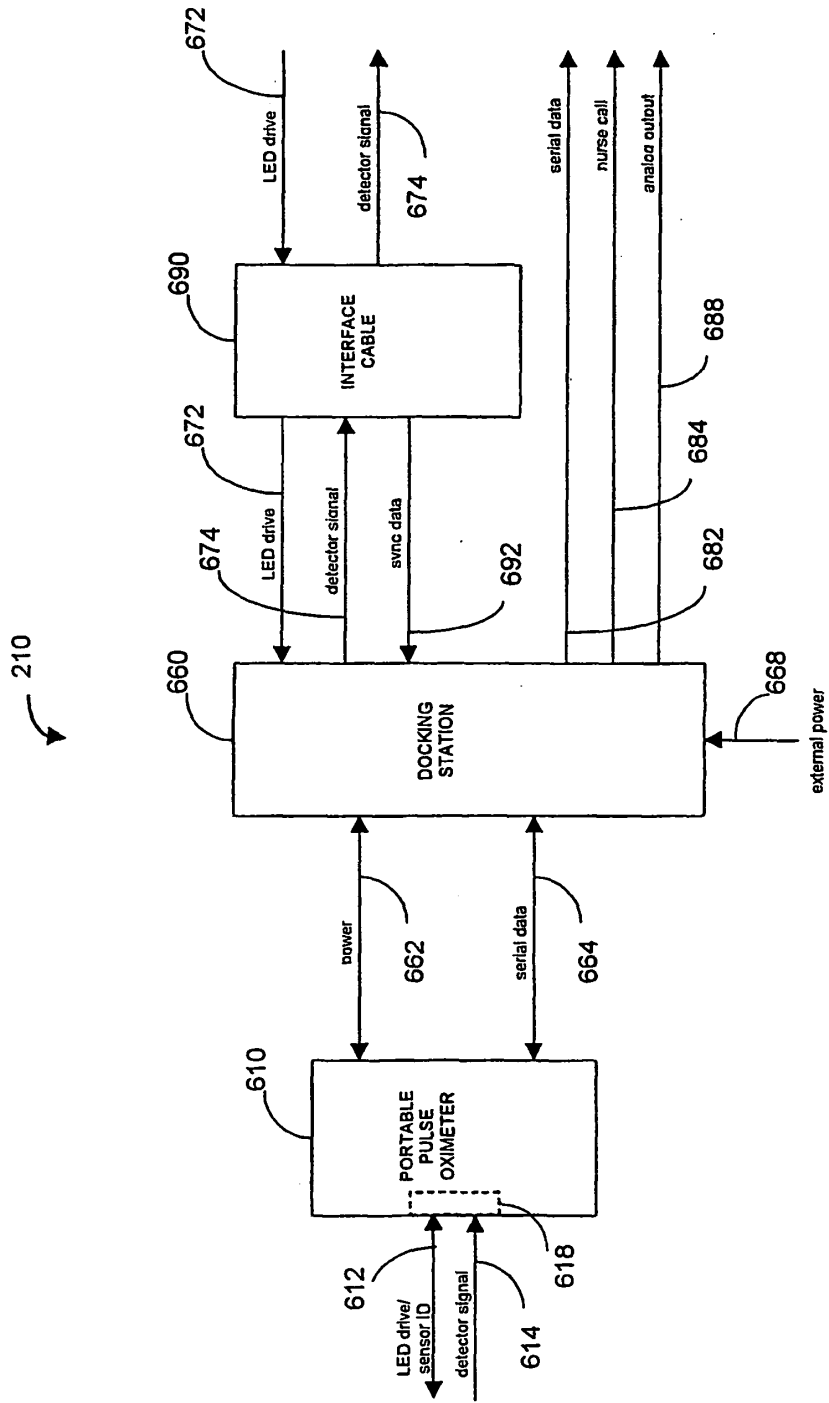

FIG. 6

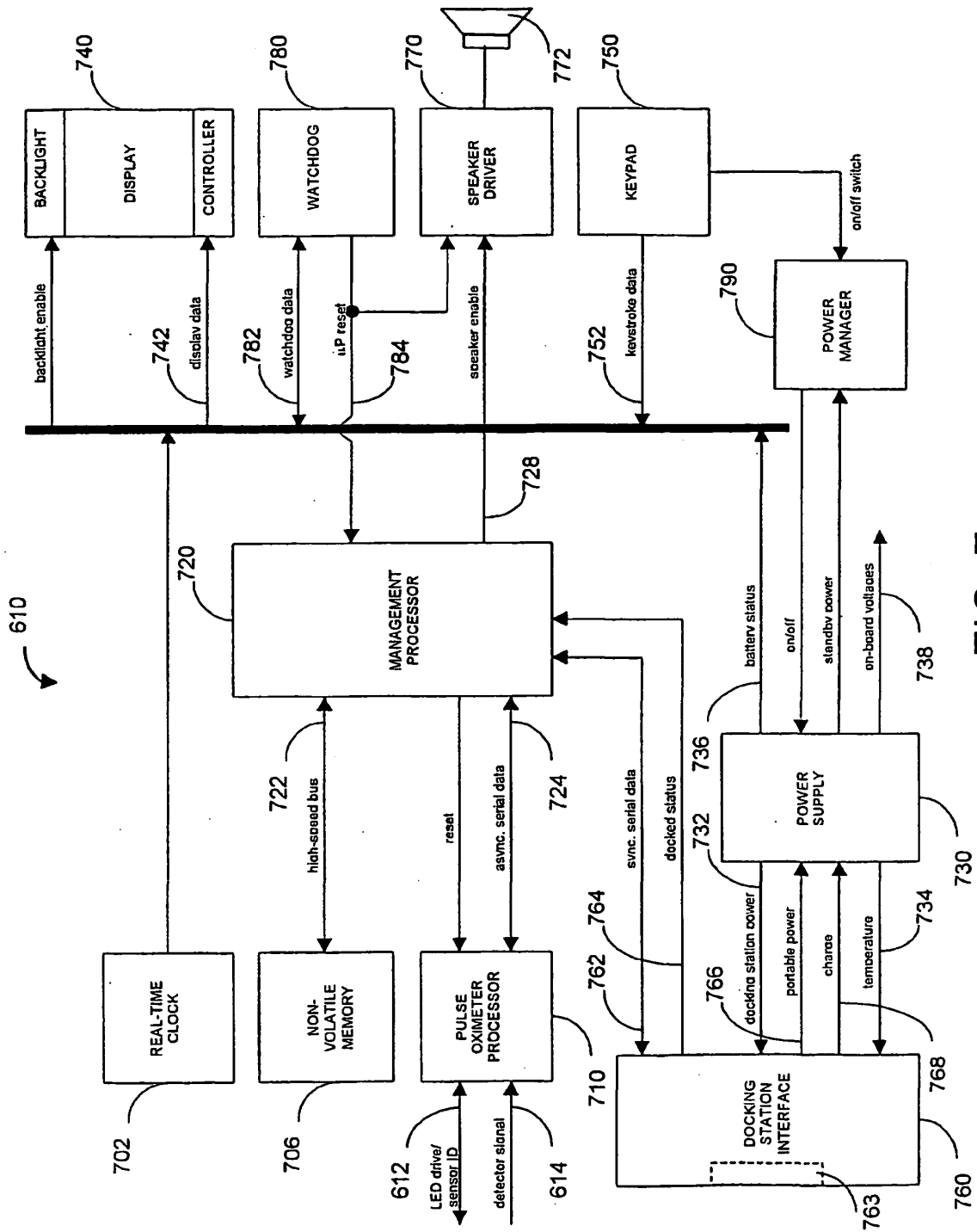

FIG. 7

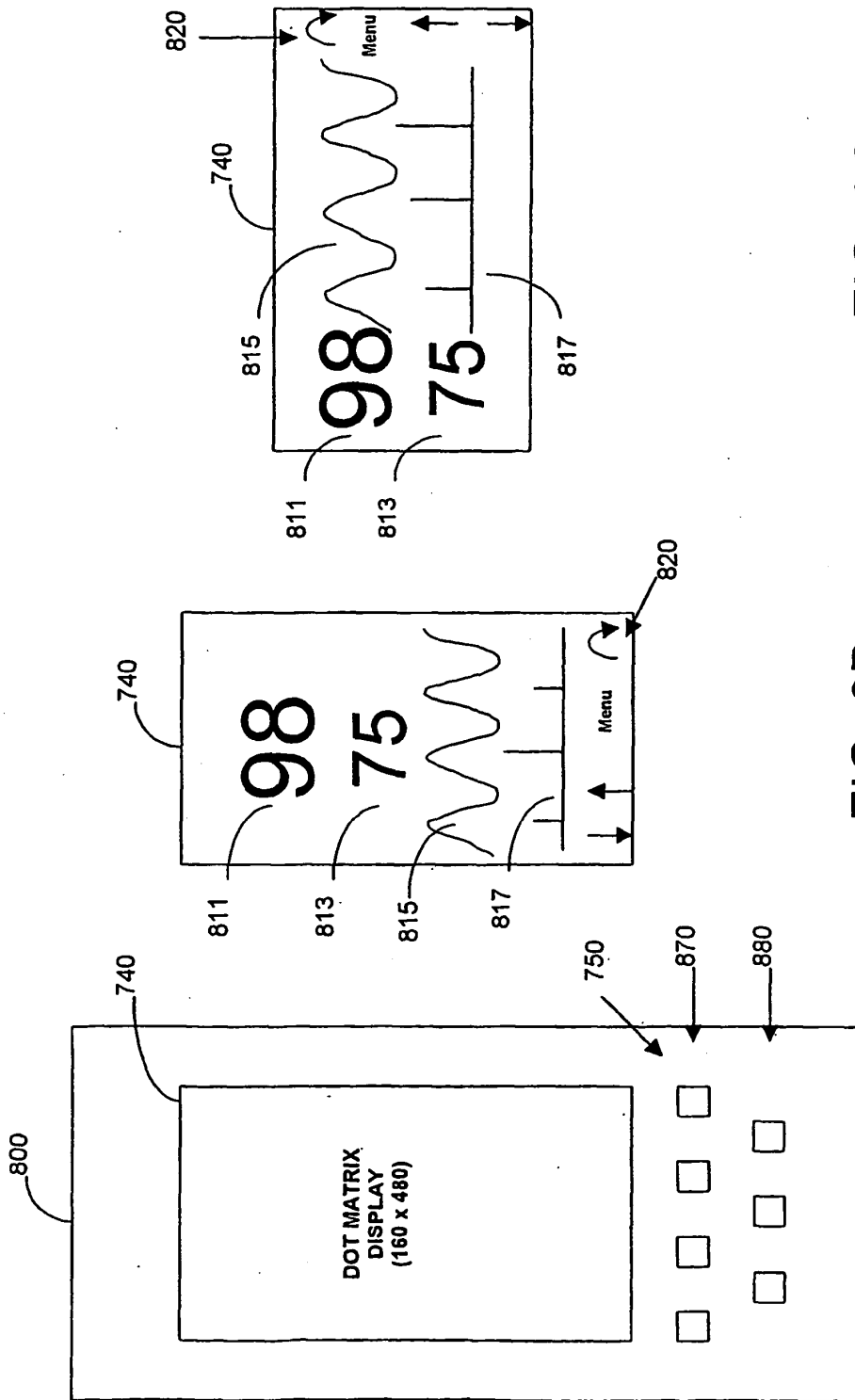

FIG. 8C

FIG. 8B

FIG. 8A

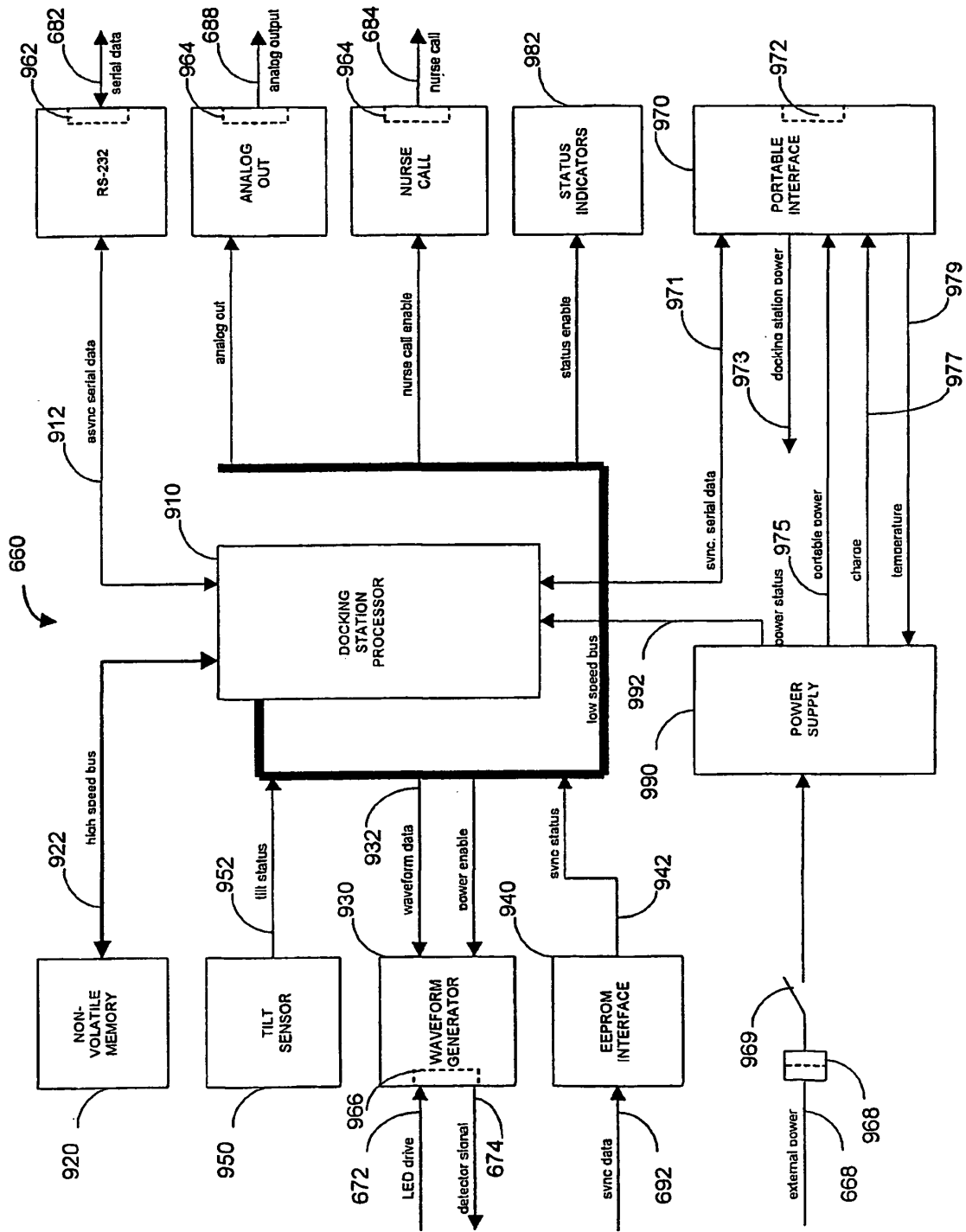

FIG. 9

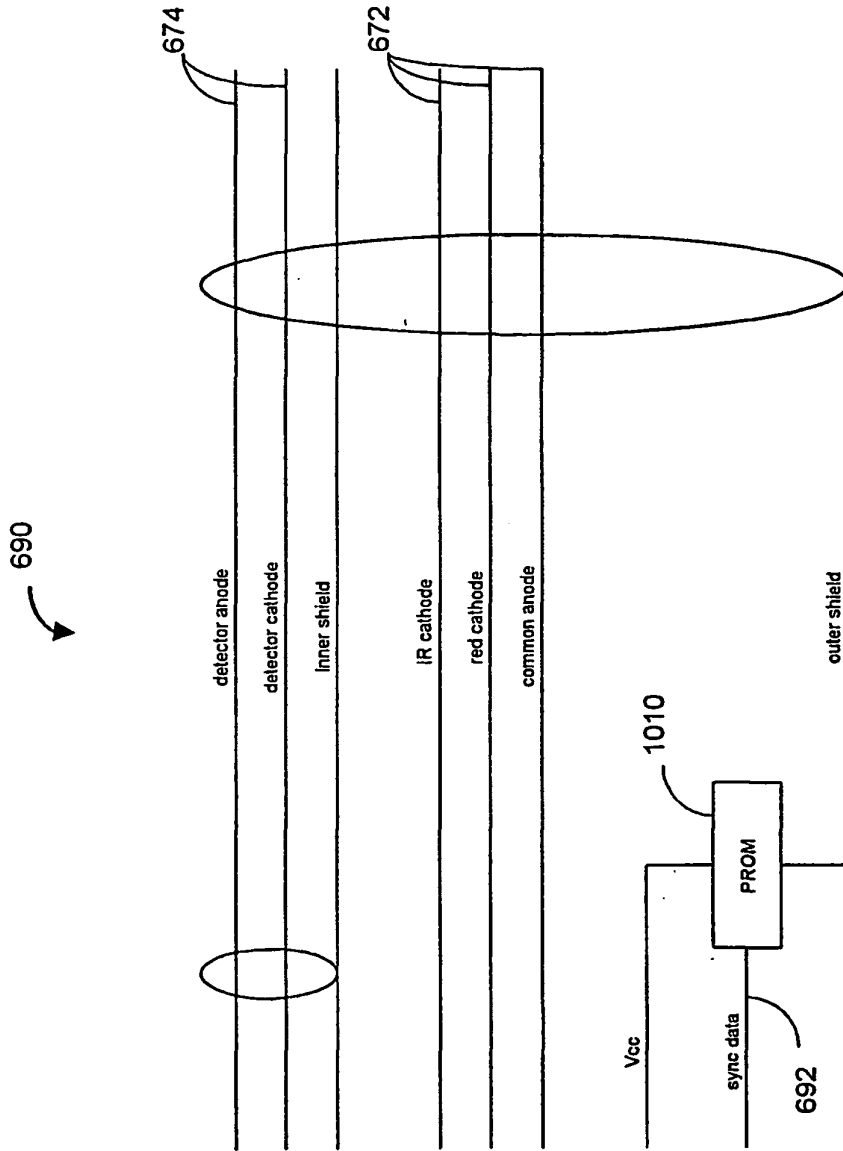

FIG. 10

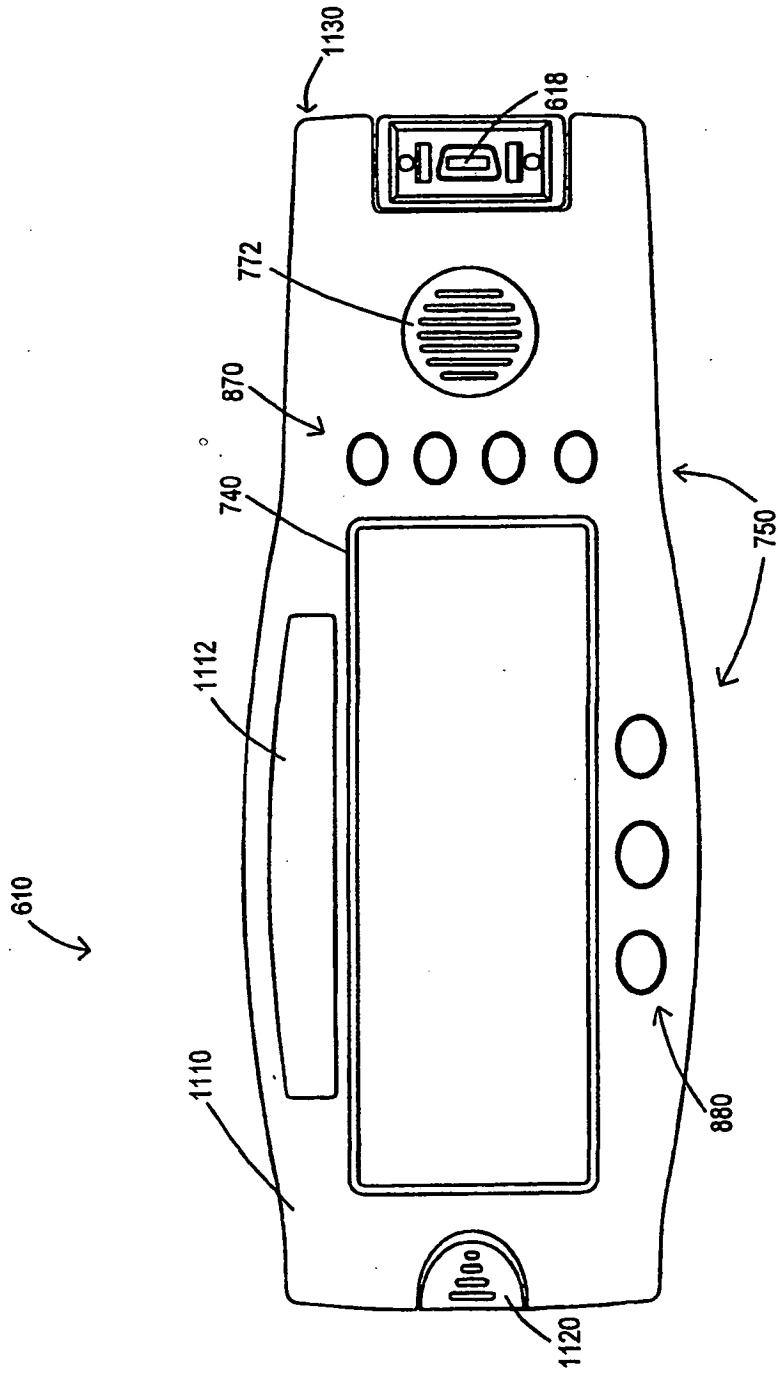

FIG. 11A

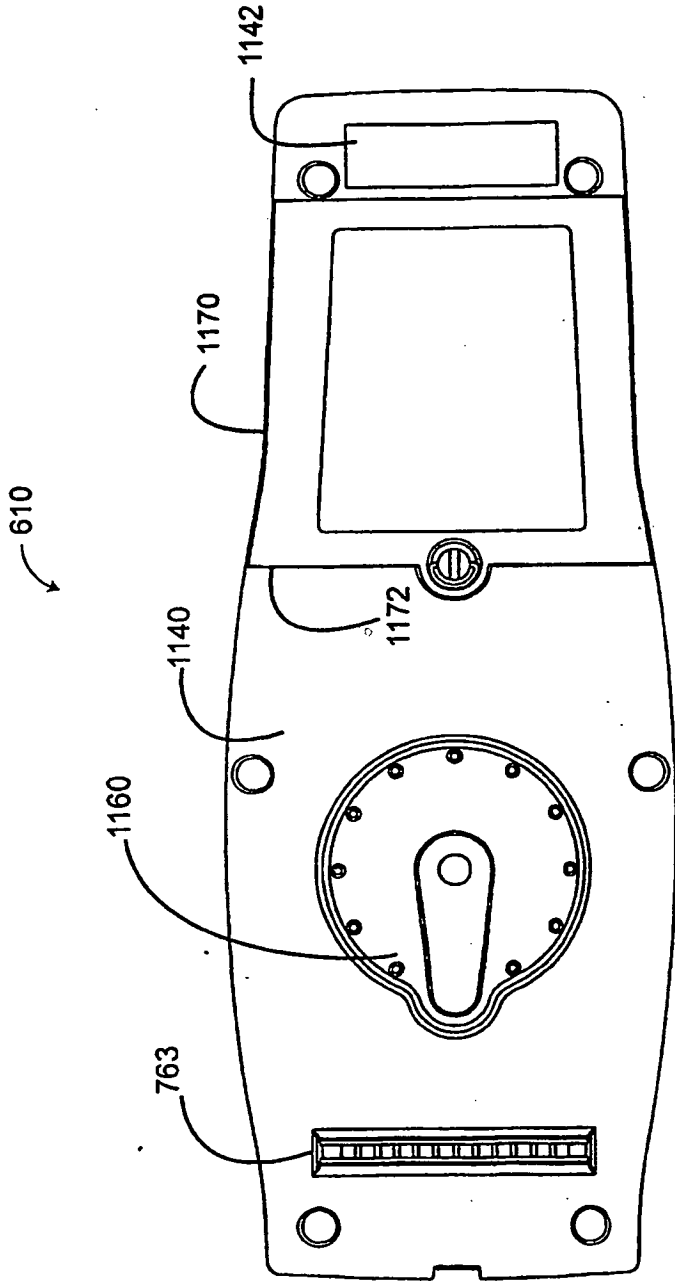

FIG. 11B

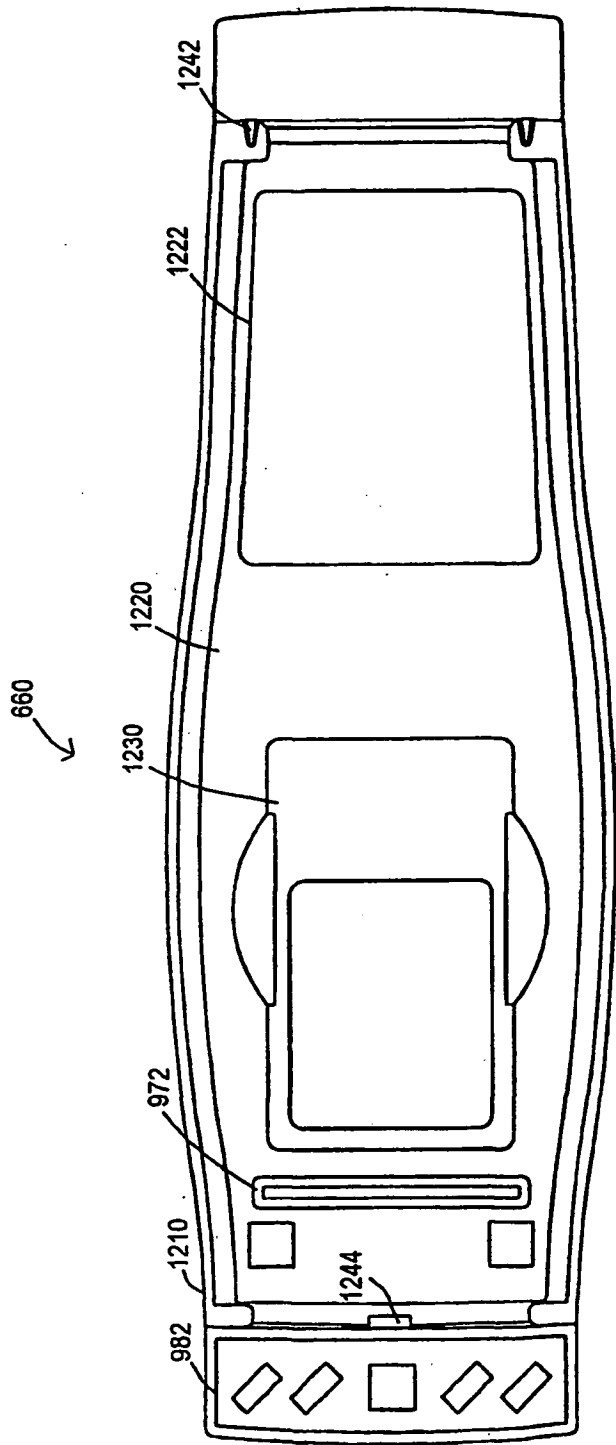

FIG. 12A

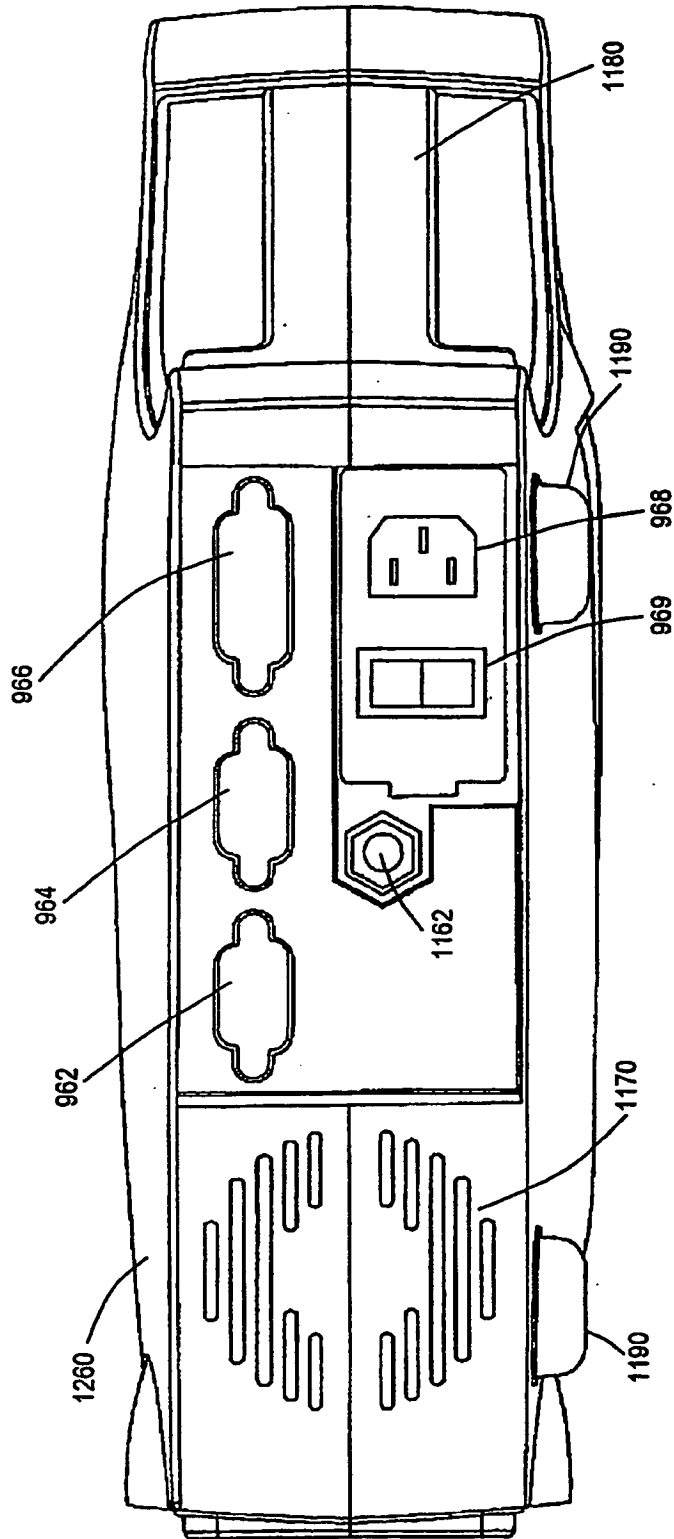

FIG. 12B

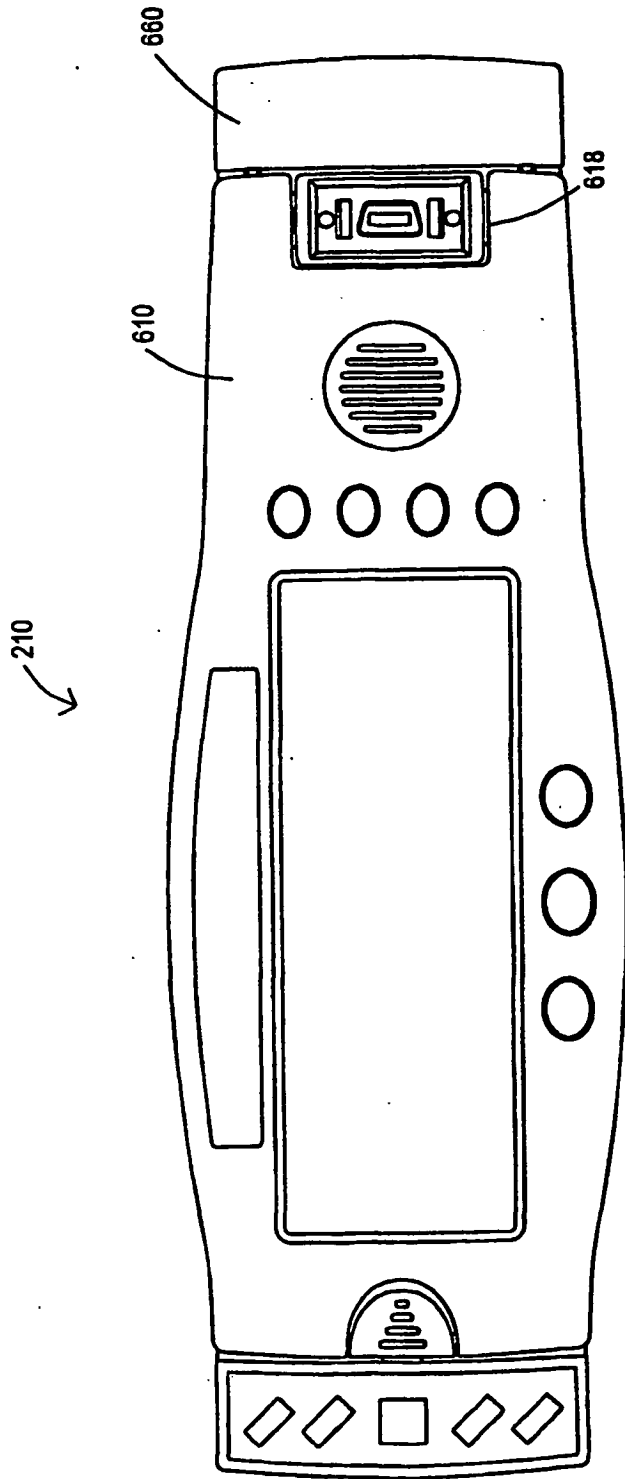

FIG. 13

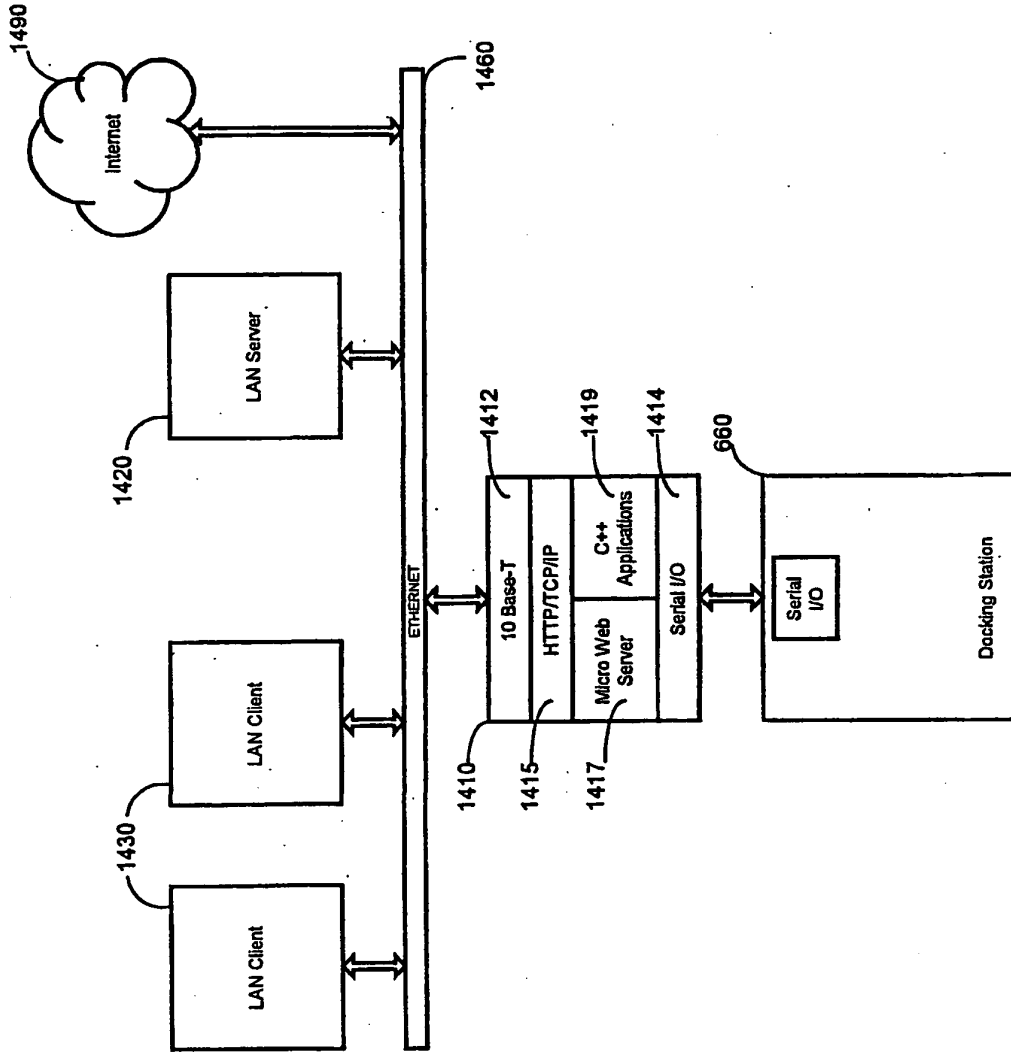

FIG. 14

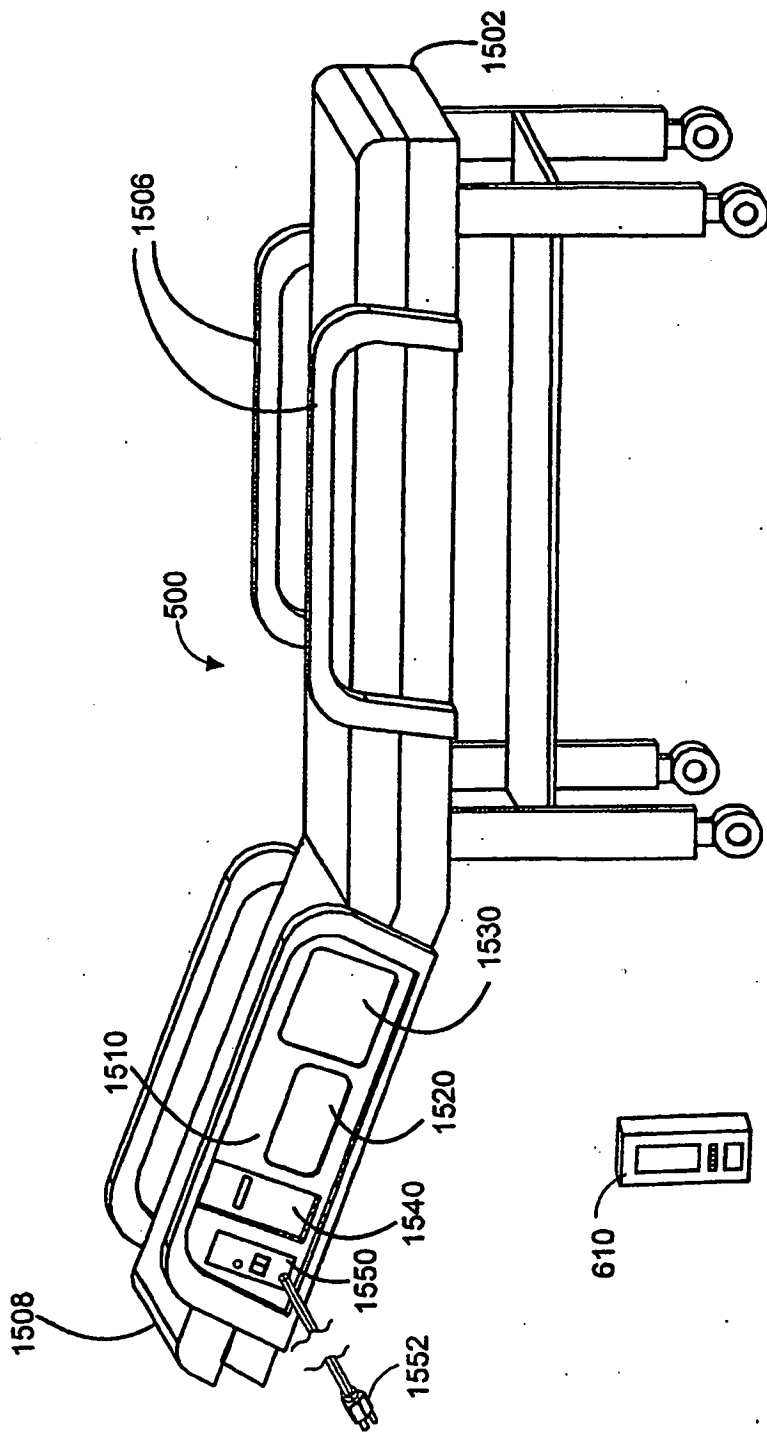

FIG. 15

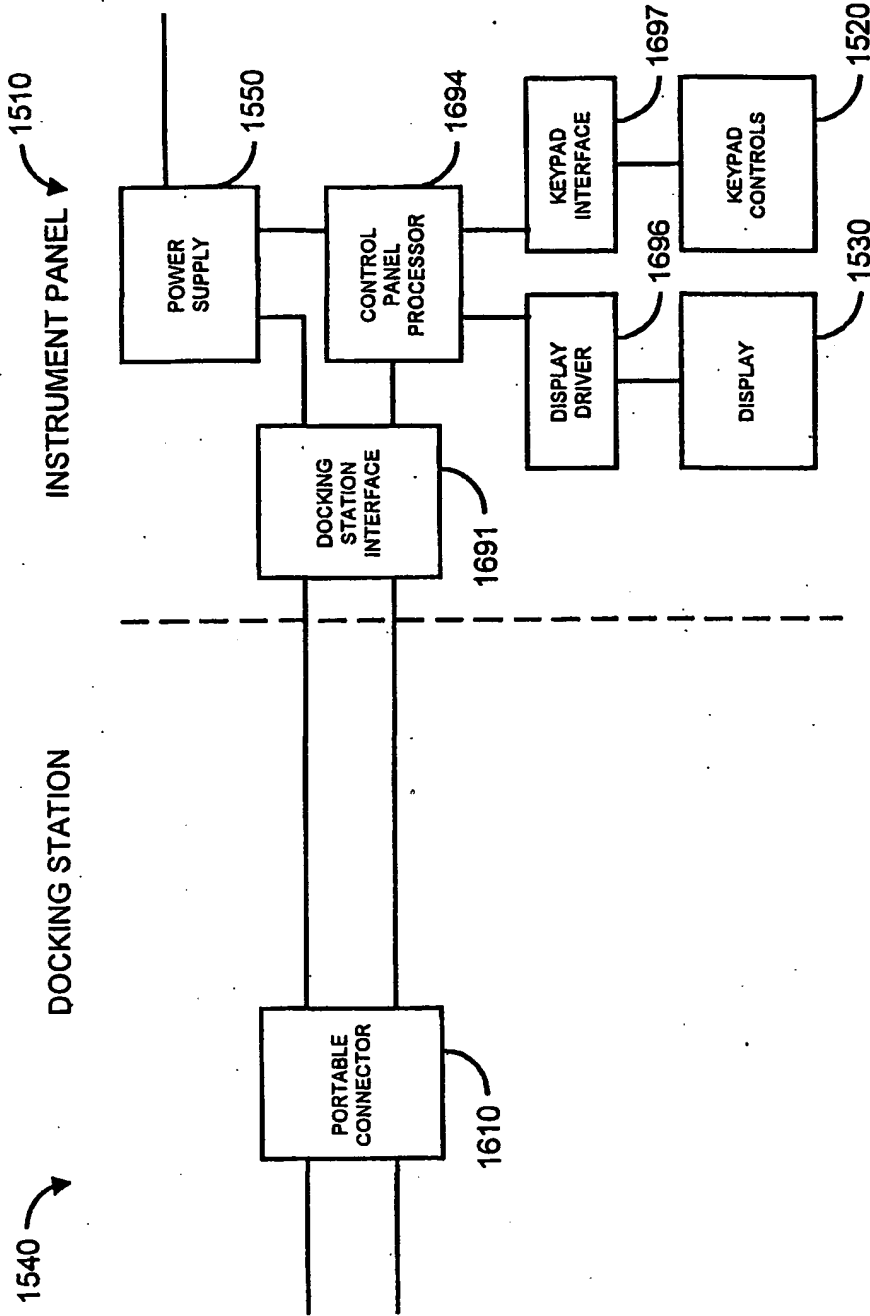

FIG. 16

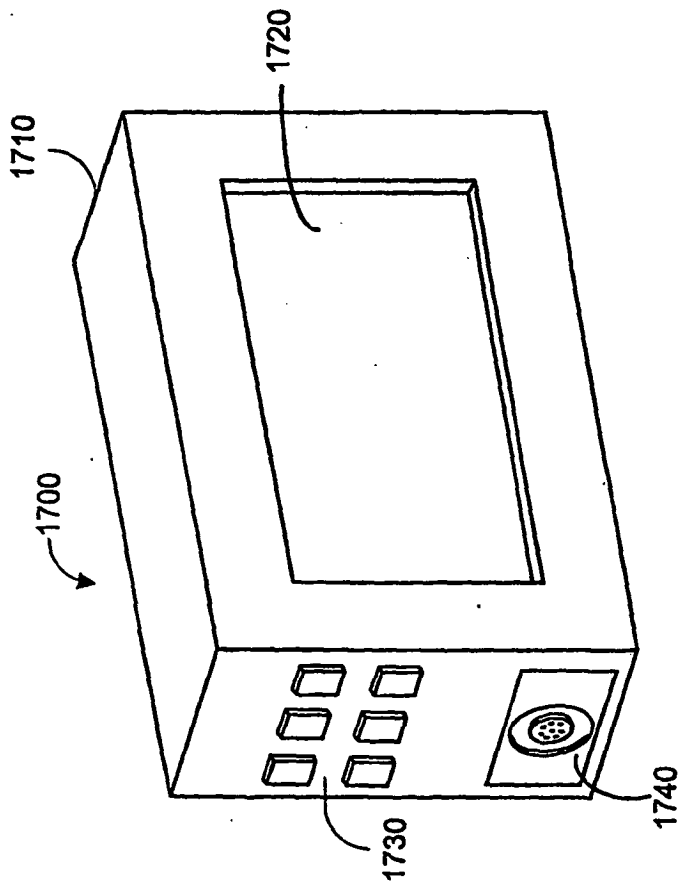

FIG. 17A

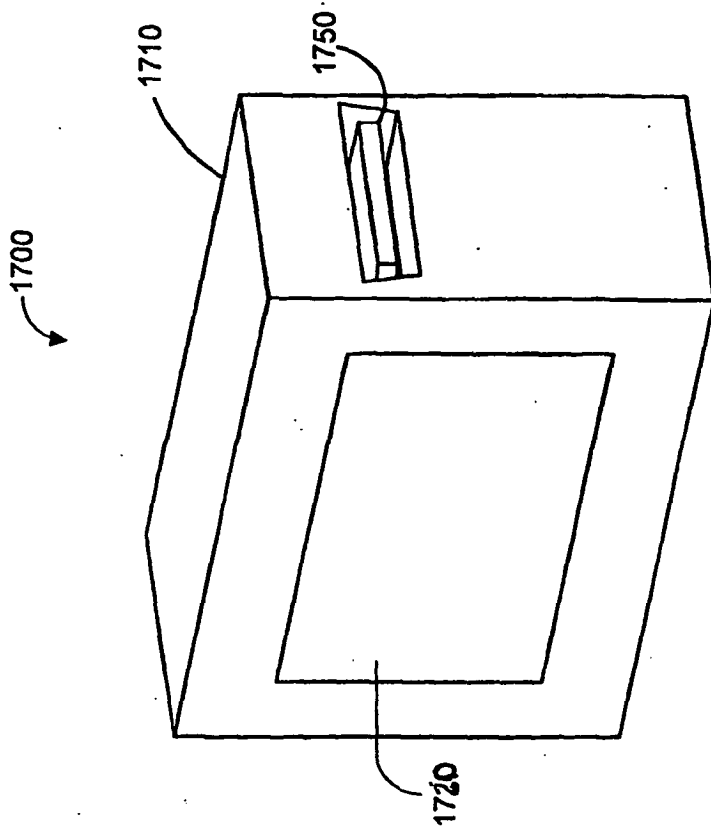

FIG. 17B

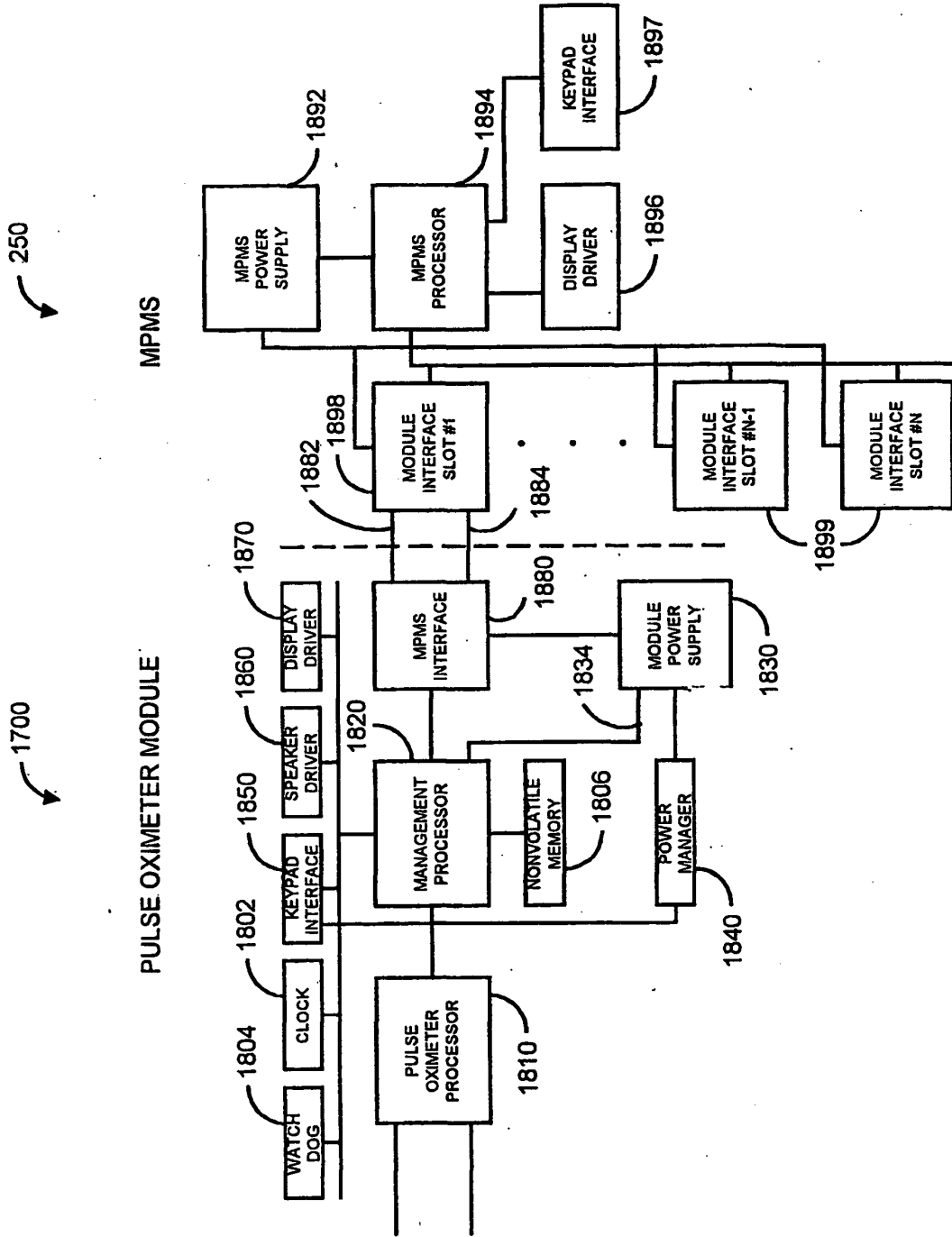

FIG. 18

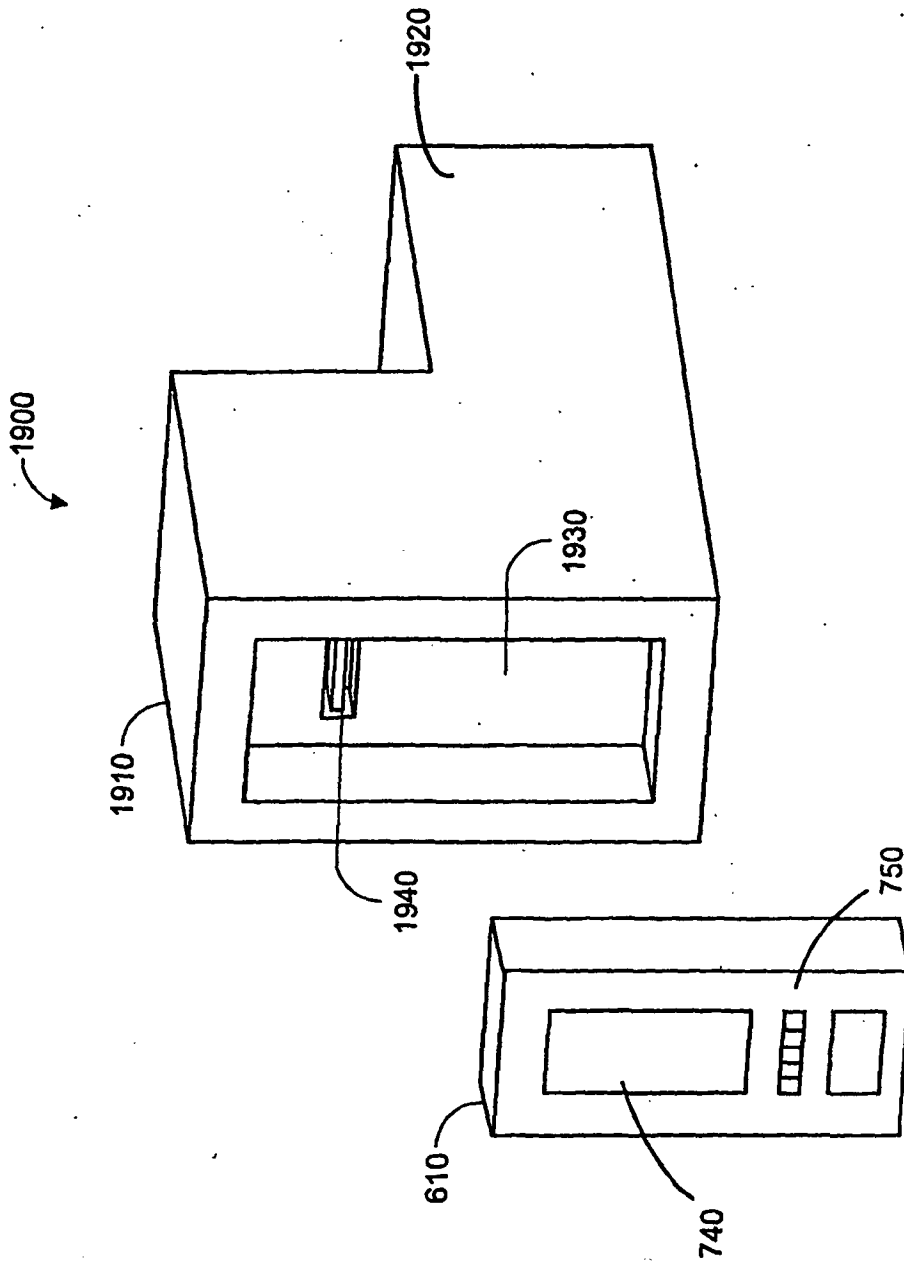

FIG. 19

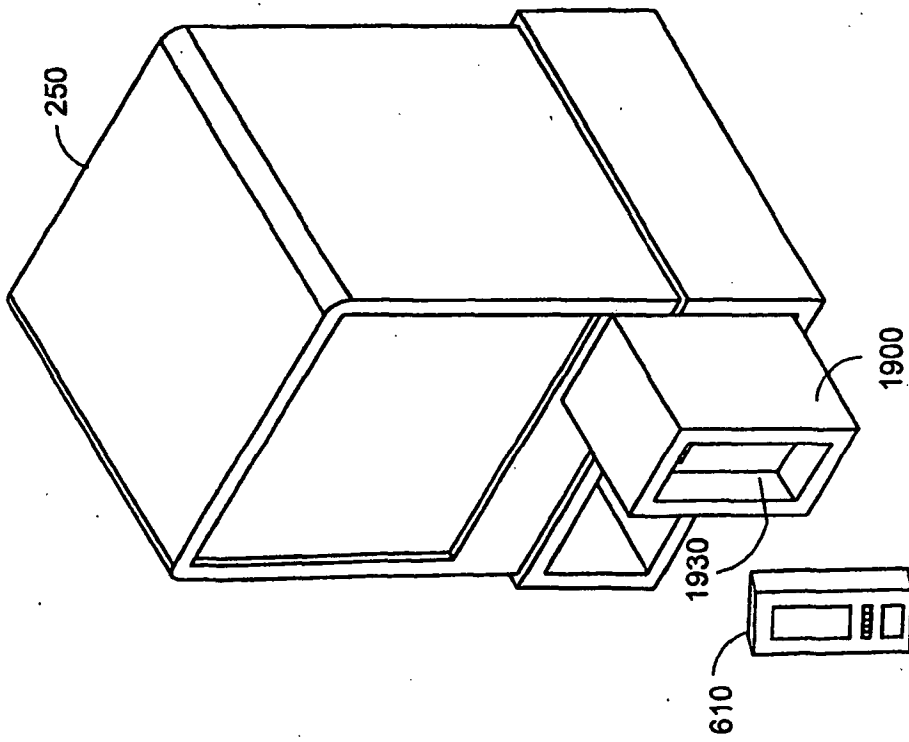

FIG. 20

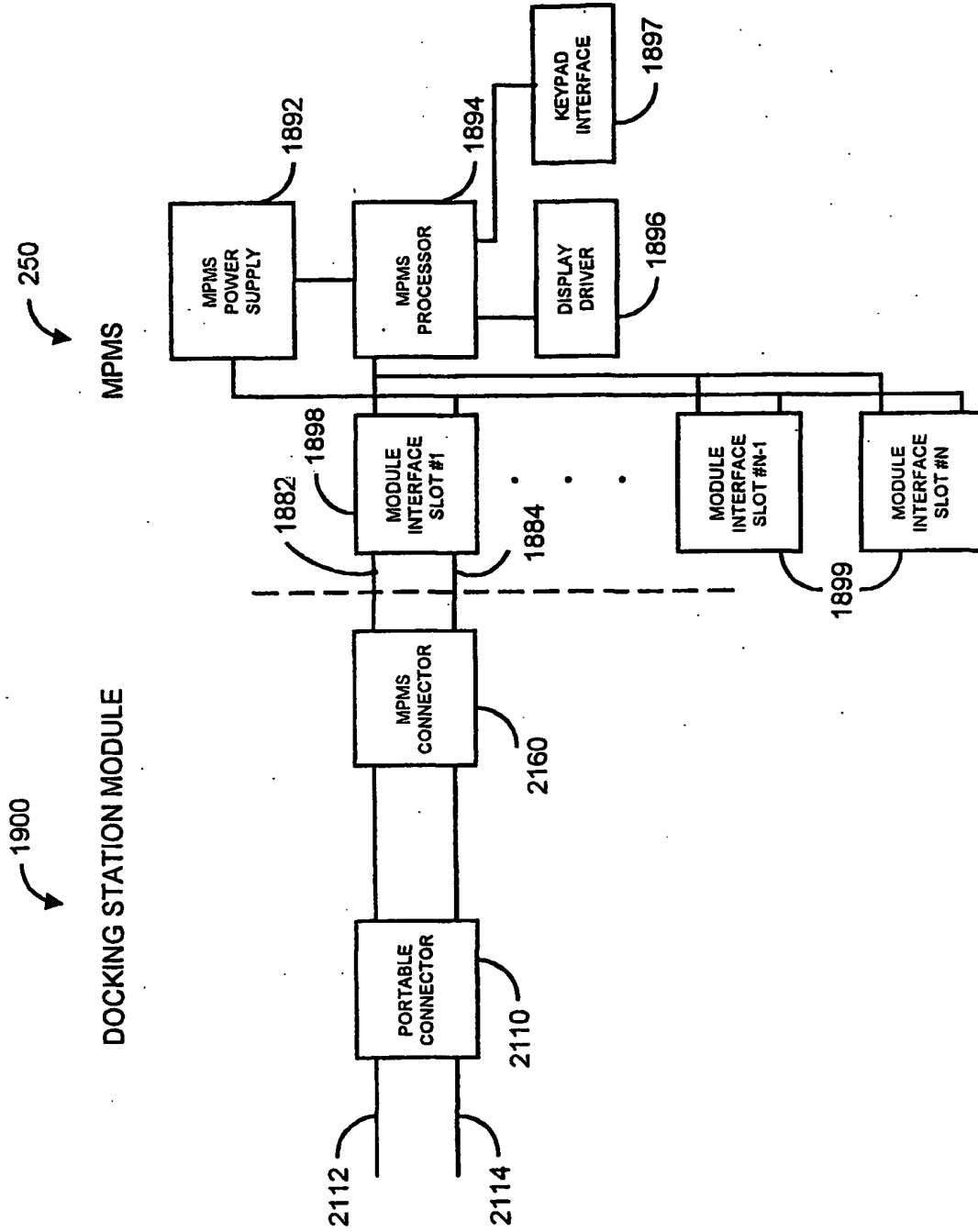

FIG. 21

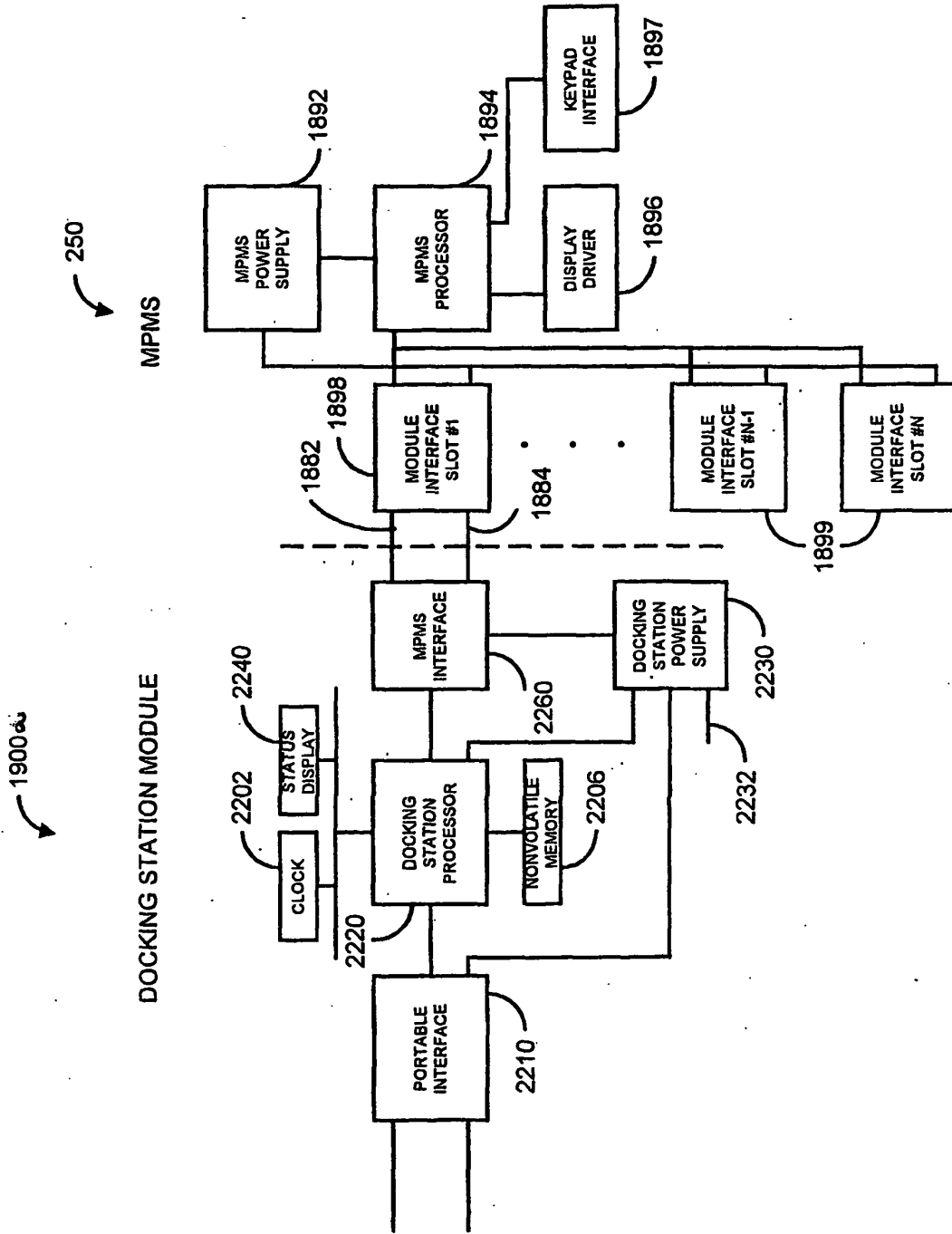

FIG. 22

**REFERENCES CITED IN THE DESCRIPTION**

*This list of references cited by the applicant is for the reader's convenience only. It does not form part of the European patent document. Even though great care has been taken in compiling the references, errors or omissions cannot be excluded and the EPO disclaims all liability in this regard.*

**Patent documents cited in the description**

- WO 00142911 A [0009]
- US 5632272 A [0027] [0043]
- US 5638818 A [0027] [0043]
- US 5758644 A [0039]

专利名称(译)	双模式脉搏血氧仪		
公开(公告)号	<a href="#">EP1309270B1</a>	公开(公告)日	2009-07-01
申请号	EP2001962370	申请日	2001-08-14
[标]申请(专利权)人(译)	梅西莫股份有限公司		
申请(专利权)人(译)	Masimo公司		
当前申请(专利权)人(译)	Masimo公司		
[标]发明人	ALI AMMAR AL CAROTHERS DON DALKE DAVID DIAB MOHAMED K GOLDMAN JULIAN KIANI MASSI E LEE MICHAEL NOVAK JEROME SMITH ROBERT VADEN VAL E		
发明人	ALI, AMMAR, AL CAROTHERS, DON DALKE, DAVID DIAB, MOHAMED, K. GOLDMAN, JULIAN KIANI, MASSI, E. LEE, MICHAEL NOVAK, JEROME SMITH, ROBERT VADEN, VAL, E.		
IPC分类号	A61B5/00		
CPC分类号	A61B5/7445 A61B5/0002 A61B5/0205 A61B5/021 A61B5/0402 A61B5/0476 A61B5/14551 A61B5/742 A61B2560/0271 A61B2560/0443 A61B2560/0456		
代理机构(译)	法思博事务所		
优先权	09/641542 2000-08-18 US		
其他公开文献	EP1309270A1		
外部链接	<a href="#">Espacenet</a>		

#### 摘要(译)

脉冲血氧计 ( 210 ) 具有集成模式, 其中其作为用于多参数患者监测系统 ( MPMS ) ( 250 ) 的插入模块操作。脉冲血氧计 ( 210 ) 还具有便携模式, 其中作为电池供电的手持式或独立式仪器与MPMS ( 250 ) 分开操作。脉冲血氧计 ( 210 ) 具有传感器端口, 其接收光 - 体积描记信号作为内部处理器的输入。脉冲血氧计处理该传感器信号以获得氧饱和度和脉搏率测量值。在便携式模式中, 该信息在其显示器 ( 340 ) 上提供, 并存储在存储器中以用于趋势能力。键盘 ( 510 ) 提供用于便携式模式下的操作控制的用户界面。在集成模式中, 脉搏血氧仪提供氧饱和度和脉搏率通过通信接口与MPMS ( 250 ) 一起测量, 以及先前存储的趋势数据, 并显示在MPMS监视器上。MPMS ( 250 ) 还在集成模式下提供脉冲血氧计 ( 210 ) 的外部电源和操作控制。或者, 对接站 ( 660 ) 作为插入式模块操作, 该插入式模块在便携式脉冲血氧计 ( 610 ) 和来自各种制造商的MPMS仪器之间提供机械和电气接口。在集成模式中, 便携式脉搏血氧计 ( 610 ) 对接到对接站 ( 660 ), 对接站 ( 660 ) 又插入一个或多个MPMS插槽 ( 290 ) 中。对接站

( 660 ) 可以用作对接的便携式脉搏血氧计 ( 610 ) 和 MPMS ( 250 ) 之间的简单电通道装置，或者它可以提供 MPMS 通信。接口。

$$RD/IR = (Red_{AC}/Red_{DC}) / (IR_{AC}/IR_{DC})$$