

(19)  
(12)

(KR)  
(A)

(51) Int. Cl.<sup>7</sup>  
C09K 11/06

(11)  
(43)

10-2004-0011312  
2004 02 05

(21) 10-2002-0045095  
(22) 2002 07 30

(71) ( ) 7 1661-4 408

(72) 8-2 A308-710

820 305

(74)

:

(54)

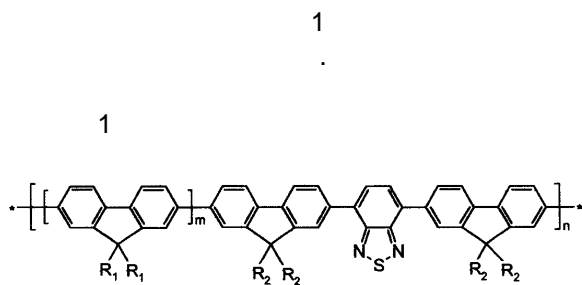

1, R1, R2, C 1-20, C 1-20, C 1-20, C 6-20, C 1-20, C 6-20, C 1-20, C 6-20, R 1, R 2, P, S, O, N, C-9, C 3-12, m, 0, 1, n, 5

2

1

2

11... 12...

13... 14...

15... 16...

17...

가

1

Tang

[Tang et al., Applied Physics Letters 51, 913(1987)]

Kido 40,000cd/m2

[Kido et al., IEEE Transactions on Electron Devices 40, 1342(1993)]

0]

(photoluminescence)

(electroluminescence)

가 가 (1,4-), PPV[Burroughs et al., Nature 347, 539(1990)], MEH-PPV 가 PPV [5,189,136], PPP V [Heeger et al., Synthetic Metal 62. 35(1994)], 가 [Braun et al., Journal of Applied Physics, 72, 564(1992)], 가 [Yoshino et al., Jpn. J. Appl. Phys., L587 (1995)], [Heeger et al., Synthetic Metal 62. 35(1994), J. Electron. Mater., 23, 45

3(1994)]

가 [5,408,109]

가

가

Yoshino

hino et al., Japanese Journal of Applied Physics 30, L1941(1991)]

[Fukuda et al., 02,269,734, Yos

(Alternate)

가

가

(Random)

가



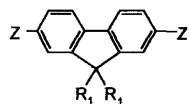

2, R<sub>1</sub>, Z, -B(OH)<sub>2</sub>, -B(OR)<sub>2</sub>,



Z, R<sub>3</sub>, C<sub>1-10</sub>, R<sub>4</sub>, C<sub>2-10</sub>.

(2) [Remmers et al., Macromolecularr Rapid Communicatons, Vol. 17, pp.239-2539(1986)]

Z=B(OH)<sub>2</sub>.

3

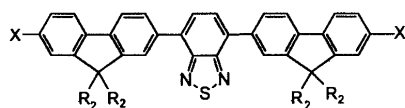

3, R<sub>2</sub>

2483(1995)]

'Suzuki Reaction'

[N. Miyaua, A. Suzuki, Chemical Reviews, Vol. 95, pp. 457-2483(1995)]

1

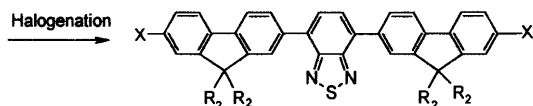
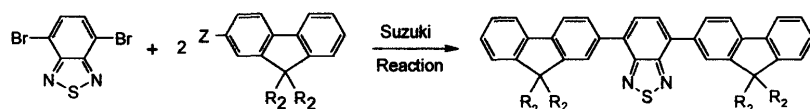

1, R<sub>1</sub>, R<sub>2</sub>, X, Z

[ Colon et al., Journal of Polymer Science, Part A, Polymer Chemistry edition, vol 28, p.367 (1990), Journal of Organic Chemistry,51,p.2627 (1986)]

2-

p.1991-2003(1990)]

70

10

100

[Rehalin et al., makromoleculaire Chemie, vol. 191,

995)]

[N. Miyaua, A. Suzuki, Chemical Reviews, Vol. 95, pp. 457-2483(1

2

70 120

3

HBr

2 100  
(chain-terminator)

가  
 [Colon et al., Journal of Polymer Science, Part A, Polymer Chemistry Edition, Vol. 28, p.367(1990), Journal of Organic Chemistry, Vol.51, p.2627(1986)]

가

[Ioyada et al., Bulletin of the Chemical Society of Japan, vol 63, p.80(1990)]

2가  
 10mol% 가 20 100 1 24 가

[Yamamoto et al., Progress in Polymer Science, vol.17, p.1153(1992)]

(1,5- )  
 1,5- 70 2  
 (chain-terminator)

가 가

1

1

UV- (ITO) 가 5eV , SiO2, SiNx 가

(3,4- - ),

(3,4- - )

가

(3,4- - ) 가 (3,4- - ) 가 (3,4- - ) 가

3,4- - ) 2 가 (3,4- - ) 가 (3,4- - ) 가

1,3,4- 8- PPV 1,3,4-

1

가

0.5 10 0.5 5.0 가 가

가

가

가 %

가

%

1

9,9- 2,7- (10mmol) 50ml 2.5M ( )  
 (8ml, 20mmol) -78 가 .-78 1  
 (7.5g, 40mmol) 가 -78 1 16  
 , 25ml 300ml 30 (150m  
 l x 2) NaCl (MgSO<sub>4</sub>),  
 50ml 30mmol(1.86g) 가 - 2~  
 3 85%) 95 99% (HPLC ) (70

2

4,7-Bis(7- )-2,1,3-  
 9,9- -2- (144mmol), 4,7- -2,1,3- (21.0g, 71.4mmol), ( )  
 ) (180mg, 0.156mmol), (2M, 100ml) (350ml)  
 14 (50%)  
 ol) 가 (30.6mmol), 가 (60ml) (13.7g, 77.5mm  
 가 2 (70%)

3

2 (10mmol), 9,9- -2,7- (10mmol), (30ml)  
 ( ) (180mg, 0.156mmol) (2M,  
 17ml) 15 (30mol%) 가 15 (30mol%) 가 15 (30ml)  
 , 100ml (90%) 가 . GPC , 500ml  
 5 (90%) . GPC , 12,000g/mol , 60 가 13

4

20mg , 1ml 85% . 480(1mg/100ml ) 93%

5

ITO, Mg/Ag(9/1), PEDOT(Bayer ),  
 30mg/ml ITO/PEDOT/ /Mg/Ag(9/1)  
 2500rpm .  
 2 . 10V 520cd/m2

가 ,

(57)

1.

1

1

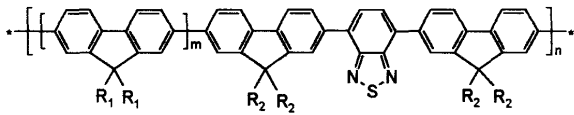

1, R1, R2, C<sub>1-20</sub>, C<sub>1-20</sub>, C<sub>1-20</sub>, C<sub>1-20</sub>, C<sub>6-20</sub>, C<sub>1-20</sub>, C<sub>6-20</sub>, R1, R2, C-9, P, S, O, N, m 0, 1, n 1

2.

1, R<sub>1</sub>, R<sub>2</sub>, C<sub>1-10</sub>, C<sub>1-10</sub>, C<sub>1-10</sub>, C<sub>1-10</sub>, C<sub>6-12</sub>, C<sub>1-10</sub>, C<sub>6-12</sub>, m 0 1, n 1, 500

3.

1, R1, R2, C<sub>1-8</sub>, C<sub>1-10</sub>

4.

1

5.

4, 가 , , , , , 1

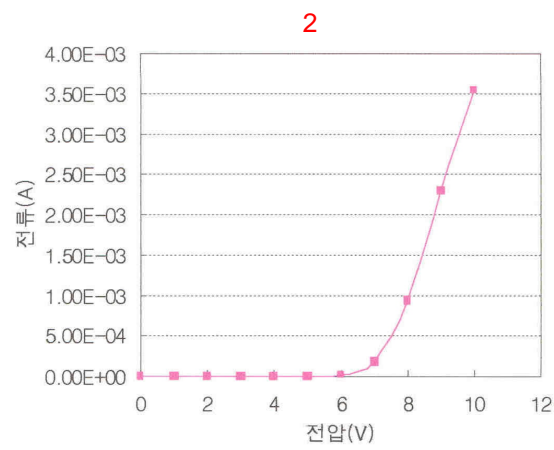
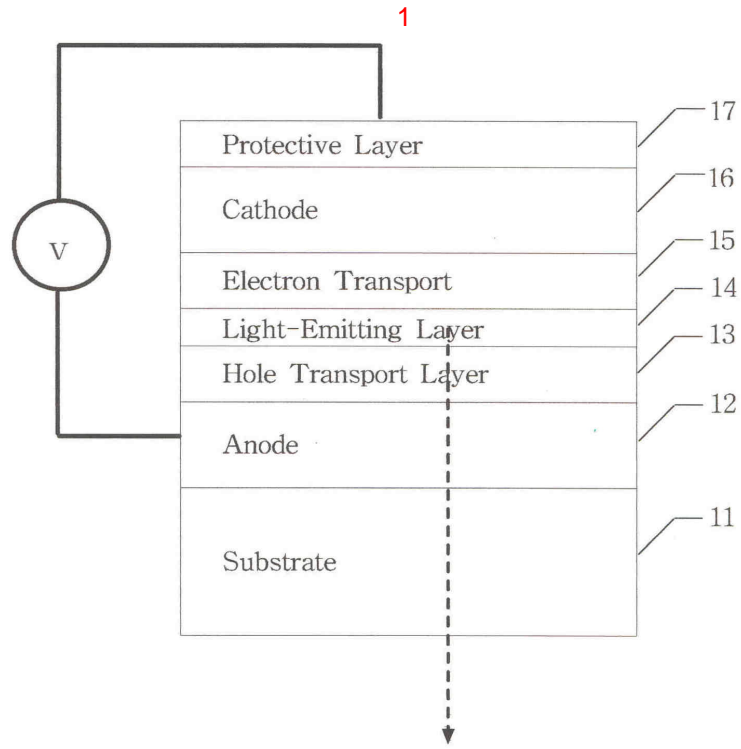

专利名称(译)	芴聚合物和含有它们的有机电致发光器件		
公开(公告)号	<a href="#">KR1020040011312A</a>	公开(公告)日	2004-02-05
申请号	KR1020020045095	申请日	2002-07-30
[标]申请(专利权)人(译)	Redgiant		
申请(专利权)人(译)	(株)红色巨人		
[标]发明人	LEE SEONGJAE 이성재 KIM CHIWOON 김치운		
发明人	이성재 김치운		
IPC分类号	C09K11/06		
CPC分类号	C08G61/123 H01L51/0039 C09K11/06 H01L51/5012 H05B33/14 C08G2261/3142 C09K2211/1416 C09K2211/1483 Y10S428/917		
代理人(译)	Gimjinhak		
其他公开文献	KR100453876B1		
外部链接	<a href="#">Espacenet</a>		

摘要(译)

用途：提供芴聚合物和含有芴聚合物的有机电致发光元件，其具有优异的发光效率和热稳定性并且可以发出绿色。组成：芴聚合物由式1表示，其中R1和R2是独立地为氢，C1-C20烃基，或C1-C20烷氧基/烷氧基，硫代烷氧基/硫代芳氧基，仲/叔胺，羟基，羧酸/磺酸，氰基和酯取代的C1-C20烃基，C6-C20芳基或C1-C20烷氧基/烷氧基，硫代烷氧基/硫代芳氧基，仲/叔胺，羟基，羧酸/磺酸，氰基和酯取代的C6-C20芳基，m为0,1和n为大于1的整数。并且有机电致发光元件含有有机电致发光元件含有芴聚合物的发光层。©KIPO 2004

