

(19)  
(12)

(KR)  
(B1)

(51) Int. Cl.<sup>7</sup>  
C09K 11/07

(45)  
(11)  
(24)

2003 11 17  
10-0406185  
2003 11 06

(21) 10-2001-0042555  
(22) 2001 07 14

(65) 2003-0006682  
(43) 2003 01 23

(73) 557-6

(72) ( )66404 904

(74)

:

(54)

가 1 2 , 가 2 ,

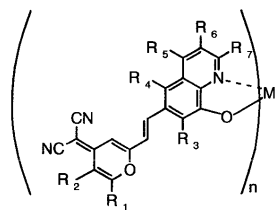

, R<sub>1</sub> 1-10 , R<sub>1</sub> 5 6 (aryl), (heteroaryl) , R<sub>2</sub> ,  
1-10 , R<sub>1</sub> 3가 , n 1,2 3 , (aryl) , R<sub>3</sub> R<sub>7</sub> (heteroaryl) , M 1,2

1

, DCM,

1  
2

가 (Organic Electroluminescence device; OELD) EL (Electroluminescence device) (Liquid Crystal Display ; LCD), (Plasma Display Panel; PDP), (Field Emission Display; FED) 가 가 가 ITO 가 Mg 가 가 가 가 가 가 가 (conjugated) (host) 가 가 가 (anthracene), (phenanthrene), (pyrene), (benzopyrene), (chrysene), (picene), (carbazole), (fluorene), (biphenyl), (terphenyl), (quaterphenyl), (triphenylene oxide), (dihalobiphenyl), (transstilbene), 1,4- (diphenyl butadiene) 가 1μm 가 ZnPBO, Balq (550nm) (Alq3), BeBq2, Almq, (460nm) -6-(p-pyran: DCM), 630nm )-4H- (4-(dicyanomethylene)-2-methyl-6-(p-dimethyl aminostyryl)-4H-DCM DCJTБ - (guest-host) - (8- ) (tris-(8-hydroxy quinolinato) aluminum: Alq3) 4,769,292 1 ne)-2-methyl-6-(p-dimethylaminostyryl)-4H-pyran: DCM )-4H- (4-(dicyanomethylene)-2-methyl-6-(p-dimethylaminostyryl)-4H-pyran: DCM) , Alq3 DCM

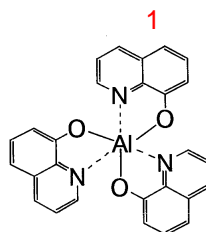

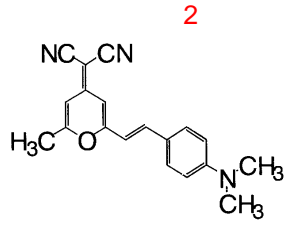

2 DCM 590nm 가 , 5,935,720 D  
 , CM , 3 .

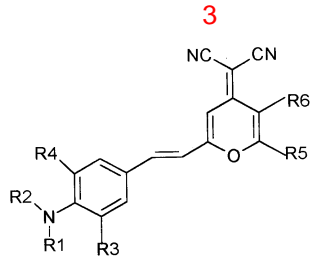

3 R 4 (ring) 1-10 , R 1 R 2 1-20 , R 1 R 2 5 6 , R 6  
 , R 5 2-20 5 6 , R 5 DCM 가 , / ,

2 가 1 , 가 2 , 4 , 4 , 1

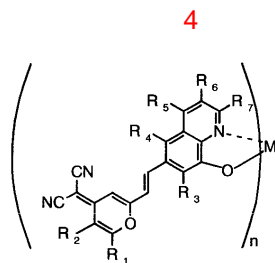

1-10 , R 1 1-10 (aryl), (heteroaryl) , R 2 ,  
 , R 1 5 6 , R 3 R 7 (heteroaryl) , M 1, 2  
 3가 , n 1, 2 3 .

가

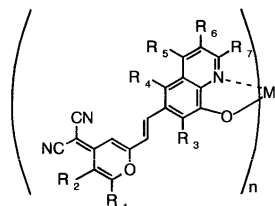

R<sub>1</sub>, R<sub>2</sub>, R<sub>3</sub>, R<sub>4</sub>, R<sub>5</sub>, R<sub>6</sub>, R<sub>7</sub> (aryl), (heteroaryl), t-  
 1-10, 1-10, 5, 6, (a  
 (heteroaryl), M 1, 2, 3가, Li, Na, K, Be, Mg,  
 Zn, Al, n 1, 2, 3, M Li, Be, Zn, Al, n 1, 2, 가

DCM

1

1

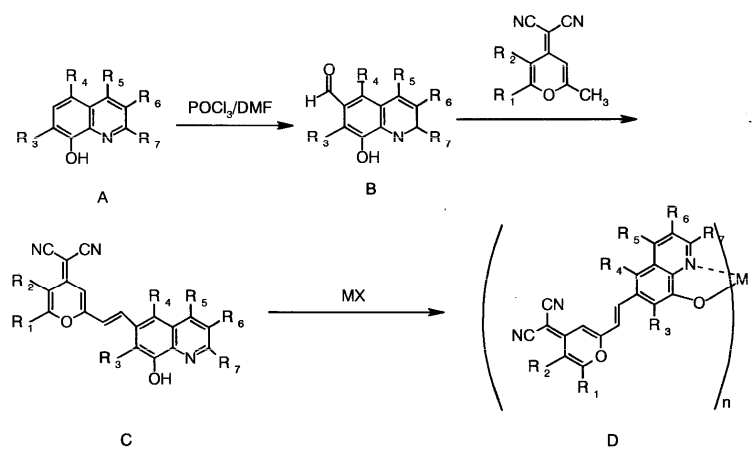

1 (ice bath)  
 가 (DMF), POCl<sub>3</sub> 가 (vilsmeier reagent), 8-  
 C B 가 4,4- -4H- C  
 D AICI<sub>3</sub>, MgCl<sub>2</sub>  
 1 (10) 가 1 (12) (hole injection, )  
 1 (12) (14) 가 2 (16) (electron inject  
 4) ) 가 1 2 (12, 16) 가 (14) (1  
 12, 16) 가 1 2 (12, 16) 가 (14) (1  
 4) (12) (10) 1 2 (12, 16) (14)  
 (guest) (dopant) 가 HOMO LUMO (14)  
 lq3) (14) (14) (A  
 - (8- ) )  
 (14) ) (A  
 1 10 % ) 10  
 %

(10) , 1 (12)

(12) (hole injection, ) , 가 (I  
 ndium Tin Oxide; ITO), (Ag) , 2 (16) (electron  
 injection, ) , 가 Al, Mg, Ca LiAl, Mg-Ag

2  
 1 2 (12, 16) 가 (14) , 2 (12,  
 16) (14) (21, 22) (25, 26) , 1 2 (12,  
 1 (21, 22) (12)

(21) 4,356,429 (porphyrinic)  
 (22) 가 , N,N'-(1-  
 )-N,N'-(25,  
 26) (16) 가 (8- ) (

, Alq3) (14), (21, 22) (25, 26)  
 5 500nm 가 .  
 (21, 22) / (25, 26)

1 2

[ 1 ]  
 $(R_4 = CH_3, R_2 = R_7, M=Al, n=3)$   
 1: (DMF) (ice-bath) 10 , 3mmol (0.4  
 58g) POCl<sub>3</sub> (drop) , 2mmol (0.29g) 8- , 40 45 12  
 (sodium acetate) pH < 8

2: 1 가 , 0.173g (1mmol) 4,4- -2,6- -4H- 0.172g (1mmol)  
 5ml 가 , 0.12g , 5-6

3: 2 가 , 0.327g (1mmol) AlCl<sub>3</sub> 0.044g (0.33mmol)

[ 2 ]  
 $(R_4 = , R_2 = R_7, M=Li, n=1)$   
 4,4- -2,6- -4H- 0.234g (1mmol) 4,4- -2- -6-  
 -4H- 1 2 , AlCl<sub>3</sub>  
 0.389g (1mmol) LiOH 0.023g (1mmol) 1

[ 3 ]  
 (ITO)가 , ITO 150 ,  
 N,N'-(1- )-N,N'- 600  
 Alq3 95 % 1 5  
 % , 380 Alq3  
 (Ag) 2000

(57)

1.

[ 4 ] , 4 .

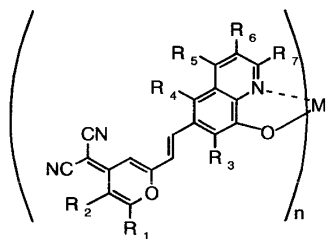

, R<sub>1</sub> 1-10 , (aryl), (heteroaryl) , R<sub>2</sub> ,  
 1-10 , R<sub>1</sub> 5 6 , R<sub>3</sub> R<sub>7</sub>  
 , (aryl) , (heteroaryl) , M 1, 2  
 3가 , n 1, 2 3 .

2.

1 , R<sub>1</sub> t- , , M Al , n 3

3.

가 1 ;  
 가 2 ;  
 1 2 , 4

[ 4 ]

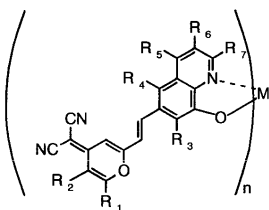

, R<sub>1</sub> 1-10 , (aryl), (heteroaryl) , R<sub>2</sub> ,  
 1-10 , R<sub>1</sub> 5 6 , R<sub>3</sub> R<sub>7</sub>  
 , (aryl) , (heteroaryl) , M 1, 2  
 3가 , n 1, 2 3 .

4.

3 , 1 ,

5.

3 , 2 ,

6.

3 ,

1

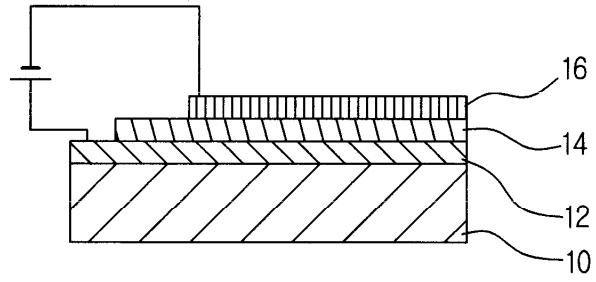

2

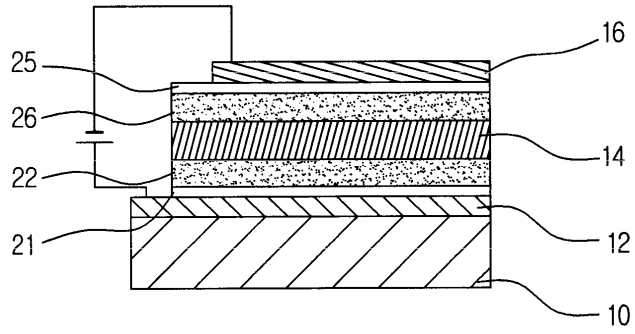

|                |   |         |            |
|----------------|---|---------|------------|
| 专利名称(译)        | 有机发光化合物和使用其的有机电致发光器件  |         |            |
| 公开(公告)号        | <a href="#">KR100406185B1</a>   | 公开(公告)日 | 2003-11-17 |
| 申请号            | KR1020010042555   | 申请日     | 2001-07-14 |
| [标]申请(专利权)人(译) | 娜我比可隆株式会社   |         |            |
| 申请(专利权)人(译)    | Neoview的隆有限公司   |         |            |
| 当前申请(专利权)人(译)  | kolon弟弟士有限公司  |         |            |
| [标]发明人         | SEOK JAI HAN<br>석재한   |         |            |
| 发明人            | 석재한   |         |            |
| IPC分类号         | C09K11/07   |         |            |
| CPC分类号         | C09K11/06 H01L51/0061 H01L51/5012 C09K2211/1029 C09K2211/1088 Y10S428/917 |         |            |
| 代理人(译)         | 이상헌<br>Gimyongdong  |         |            |
| 其他公开文献         | KR1020030006682A  |         |            |
| 外部链接           | <a href="#">Espacenet</a>   |         |            |

摘要(译)

用途：提供一种有机发光化合物和使用该化合物的有机电致发光器件，以改善耐热性并使发光颜色易于控制。组成：有机发光化合物由式4表示，其中R1是烷基C1-C10基团，芳基或杂芳基；R2为H，C1-C10的烷基或与R1连接的五元或六元碳环；R3，R4，R5，R6和R7彼此独立，并且是H，C1-C10的烷基或烷氧基，芳基或杂芳基；M是单价，二价或三价金属；有机电致发光器件包括具有高功函数的第一电极；以及n为1,2或3。具有低功函数的第二电极；和至少一个含有式4的有机发光化合物的有机电致发光层。©KIPO 2003

