

(19)



Europäisches Patentamt
European Patent Office
Office européen des brevets



(11)

EP 1 506 693 B1

(12)

EUROPEAN PATENT SPECIFICATION

(45) Date of publication and mention
of the grant of the patent:
27.09.2006 Bulletin 2006/39

(51) Int Cl.:
H05B 33/04 (2006.01)

(21) Application number: **03715192.5**

(86) International application number:
PCT/IB2003/001480

(22) Date of filing: **17.04.2003**

(87) International publication number:
WO 2003/096751 (20.11.2003 Gazette 2003/47)

(54) **ELECTROLUMINESCENT PANEL**

ELEKTROLUMINESZIERENDE VORRICHTUNG
PANNEAU ELECTROLUMINESCENT

(84) Designated Contracting States:
**AT BE BG CH CY CZ DE DK EE ES FI FR GB GR
HU IE IT LI LU MC NL PT RO SE SI SK TR**

- **VAN HAL, Henricus, A., M.**
NL-5656 AA Eindhoven (NL)
- **HASKAL, Eliav, I.**
NL-5656 AA Eindhoven (NL)

(30) Priority: **10.05.2002 EP 02076847**

(74) Representative: **Rolfes, Johannes Gerardus
Albertus et al
Philips
Intellectual Property & Standards
P.O. Box 220
5600 AE Eindhoven (NL)**

(43) Date of publication of application:
16.02.2005 Bulletin 2005/07

(73) Proprietor: **Koninklijke Philips Electronics N.V.**
5621 BA Eindhoven (NL)

(72) Inventors:
• **HIKMET, Rifat, A., M.**
NL-5656 AA Eindhoven (NL)

(56) References cited:
EP-A- 1 014 757 EP-A- 1 014 758
EP-A- 1 021 070 EP-A- 1 079 666

EP 1 506 693 B1

Note: Within nine months from the publication of the mention of the grant of the European patent, any person may give notice to the European Patent Office of opposition to the European patent granted. Notice of opposition shall be filed in a written reasoned statement. It shall not be deemed to have been filed until the opposition fee has been paid. (Art. 99(1) European Patent Convention).

Description

[0001] The present invention relates to an electroluminescent panel comprising:

- 5 - a closed casing;
- an organic device received in the casing and defining a plurality of pixels; the organic device including an organic luminescent layer between a lower and an upper electrode layer; and
- a getter means disposed in the casing.

10 **[0002]** US 5,124,204 describes (in conjunction with Fig. 1) a conventional organic electroluminescent device which is prepared by forming on a glass base plate (2) a lower transparent electrode (4), an electroluminescent layer (3), an upper electrode (5) in this order. In order to prevent moisture from reaching the EL element, it is covered by a sealing plate (7) which is adhered to the glass base plate (2) by an adhesive (6), such as an epoxy resin. Underneath the sealing plate (7) moisture absorbing material (9) is placed.

15 **[0003]** EP 1 014 757, EP 1 014 758 and EP 1 021 070 disclose an organic electroluminescent device comprising a substrate, an organic electroluminescent structure on the substrate, and a sealing member or sheet enclosing the organic electroluminescent structure. The device of EP 1 014 757 further comprises a mixture of a desiccant and an organic compound disposed on the inside surface of the sealing member and having a melting point of 70 to 200°C. The device of EP 1 014 758 further comprises a mixture of a desiccant and a high molecular weight organic compound disposed
20 on the inside surface of the sealing member and having a water absorption of up to 1.0% as measured at 23°C for 24 hours according to ASTM D570. The device of EP 1 021 070 further comprises a desiccant located on the inside of a junction for fixing the sealing sheet onto the substrate and on the outside of a space in which the organic electroluminescent structure is formed.

25 **[0004]** In order to obtain a highly reliable organic electroluminescent device, a large quantity of moisture absorbing material should be present in order to be able to absorb moisture during the whole lifetime of the organic electroluminescent device. This is due to the fact that the device is not hermetically sealed as the epoxy glue is permeable to moisture and also other gases.

[0005] Various oxide substances such as phosphorus pentoxide (P₂O₅), alkaline metal oxide, alkaline earth metal oxide, have been suggested as water absorbing material.

30 **[0006]** The invention is based on the insight that alkaline metals and alkaline earth metals can work as high capacity moisture absorbers. Such materials work effectively only when they have a large surface area. Thus they need to be in the form of small particles. However when such particles have a large surface area they are not safe and cause explosions when they come in contact with air.

35 **[0007]** It is an object of the present invention to provide a new and improved organic electroluminescent panel which is provided with a high capacity alkaline (earth) metal based getter with reduced reactivity in air.

40 **[0008]** According to the invention an organic electroluminescent panel of the type described in the preamble is characterized in that the getter means includes a non-oxidic compound or alloy comprising at least one alkaline metal or alkaline earth metal element, excluding alkaline metal hydride and alkaline earth metal hydride, dispersed on a molecular scale whereby it is still an active reactant with oxygen, hydrogen and water. Preferred embodiments of the above getter means comprise a getter material selected from the following groups:

- a) an alloy of at least one alkaline metal or alkaline earth metal with an other metal;
- b) alkaline (earth) metal carbide,
alkaline (earth) metal silicide,
- 45 alkaline (earth) metal nitride;
- c) alkaline (earth) metal intercalated in C, Si, Ge, Sn or Pb.

50 **[0009]** By containing the inventive getter means, and in particular a getter material of one of the above groups, the inventive EL panel is significantly increased in lifetime, while the danger that the alkaline (earth) metal can react with air has been minimized. By the term "intercalation" is meant that the alkaline (earth) metal atoms are arranged between two atom layers of the other material.

55 **[0010]** According to a first embodiment to the getter material is in the form of particles, the particles preferably having a mean particle size of 0.01 to 10 micron. The particles may be packed e.g. in a permeable bag. This has the advantage that the getter can pick up the moisture or gases without the internal pressure in the casing increasing, or the getter material expanding. As an alternative the particles can be sintered to a porous structure, or dispersed in a plastic sheet which forms a porous matrix.

[0011] The inventive getter materials can be advantageously be used both in so-called permeable systems and in so-called hermetically sealed systems.

[0012] By the term permeable systems are meant electroluminescent panels of the type in which the organic device is separated from the outside world by a means which is permeable (to a certain extent) for gases like oxygen and hydrogen, and moisture. An example is e.g. a panel the casing of which comprises a first substrate which supports said organic device, a second substrate disposed above and spaced from said organic device, a (permeable) organic sealing means sealing a space between the first and second substrates at peripheral portions thereof.

[0013] By the term hermetically sealed systems are meant electroluminescent panels of the type the organic device is separated from the outside world by an impermeable seal, so that no gases or moisture can pass the seal, in either direction. An example is e.g. an encapsulated device in which the casing comprises a substrate which supports the organic device, an inorganic sealing layer positioned to form a laminated structure with said organic device and forming together with the substrate a hermetically sealed encapsulation for said organic device.

[0014] For acting as a moisture getter the getter is disposed in the casing out of contact with the organic device,

[0015] However, in the case of hermetically sealed devices it may be necessary to trap gases such as oxygen and hydrogen which form during the operation of the devices in the organic (polymer) layer. By this trapping increase of the internal pressure is avoided. The moisture traps described here can also act as hydrogen and oxygen trap.

[0016] In order to be able to trap hydrogen and/or oxygen produced in the organic (polymer) layer, the getter should be in physical connection with the organic layer. By the term in physical connection is meant: in direct or indirect contact. Indirect contact means that the getter is separated from the organic layer by a gas permeable layer.

[0017] Accordingly, a further embodiment of the invention is characterized in that in a hermetically sealed system the getter material is located at a position in physical connection with the organic device.

[0018] In the framework of the invention alloys of at least one alkaline (earth) metal with Al have found to be very effective, in particular $Ba_4 Al$.

[0019] Alkaline (earth) metal silicides, carbides and nitrides have also been found to be suitable. Alkaline (earth) metal hydrides however are not suitable. Calcium hydride e.g. picks up moisture according to the following reaction scheme:

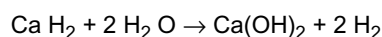

[0020] This means that hydrogen is generated together with water removal. This may lead to explosions, in particular in a large panel, e.g. if through a crack in the glass substrate or in the sealing a substantial amount of $H_2 O$ enters the panel. The invention also relates to a getter means as described above for general purposes.

[0021] These and other objects and features of the present invention will become clearer from the following description taken in conjunction with preferred embodiments thereof with reference to the accompanying drawings, in which:

Fig. 1 is a schematic sectional view of a first type of electroluminescent panel;

Fig. 2 is a schematic sectional view of a second type of electroluminescent panel;

[0022] Fig. 1 shows an electroluminescent (EL) display panel 1, comprising a glass substrate 2 on which several layers have been deposited by means of processes which are generally known in the art, such as physical or chemical vapor deposition, or ink-jet printing. The device 1 comprises an active or emissive layer 3 comprising an organic electroluminescent material, such as a coumarin (organic LED), or a conjugated polymer like PPV (poly(P-phenylene vinylene)) or a PPV-derivative (polymer LED), sandwiched between two patterns of electrode layers of an electrically conductive material. In this example, the electrode layers comprise column or data electrodes 4, which are deposited directly onto the glass substrate 2, and row or selection electrodes 5, thus forming a matrix of light emitting diodes (LED's). At least electrode 4 is made of a material, such as Indium Tin Oxide (ITO, that is transparent to the light emitted by the active layer 3. During operation, the column electrodes 4 are driven such that they are at a sufficient high positive voltage relative to the row electrodes 5, to inject holes in the active layer 3.

[0023] The stack of layers 3, 4 and 5 is contained in a cavity 8 which is formed by a sealing member or cover 7, which is secured to the glass substrate 2 by an adhesive 6, such as a thermosetting two-component epoxy resin. The sealed container formed by the glass substrate 2 and the cover 7 sealed onto the substrate 2 using the adhesive 6, is on the inside provided with a moisture absorption means, or getter, 9 such that the moisture absorbing material is spaced from the stack of layers 3, 4 and 5. For example, the moisture absorption means, or getter, 9 may be contained in a permeable bag attached to the cover 7 as depicted in Fig. 1.

[0024] In an example the getter material is $Ba_4 Al$, in the form of particles having a mean size between 0.01 and 10 microns.

[0025] However, also the other inventive getter materials mentioned before are suitable.

[0026] The Fig. 1 panel is of the permeable type, as it has a sealing member, or cover, 7 which is secured to the glass substrate 2 by an adhesive 6. The sealing member 7 is not in physical contact with the organic device.

[0027] A second type of luminescent panel has a more compact construction, in which adjacent layers are in physical contact, there is no adhesive seam and no moisture getter (trap).

[0028] Fig. 2 shows a cross-section of an example of a hermetically sealed electroluminescent panel of the layer stack (or: laminated) type. A substrate 12, which may be a glass substrate or e.g. a "passivated" plastic substrate carries a lower electrode layer 14, an organic (polymer) electroluminescent material layer 13 and an upper electrode layer 15, which together form the organic device. The layer stack 13, 14, 15 is completed by a sealing layer 17 of inorganic material, e.g. a carbide or a nitride, in particular silicon nitride, or an electrically insulating, moisture impermeable, metal oxide, which covers the organic device. Together with substrate 12, sealing layer 17 "encapsulates" the organic device. The resulting EL panel 11 can be very thin. The organic electroluminescent layer 13 may comprise one, or a plurality of organic layers. In the following the expression "organic layer" will be used irrespective of the fact whether there is one or a plurality of organic layers.

[0029] However a problem with this approach is the production of hydrogen gas during the operation of the panel. The gas is produced mainly by the electrolysis of water remaining in the electroluminescent polymer. Some crosslinking reactions within the polymer can also lead to the formation of hydrogen gas within the system. As a result of gas production volume expansion and bursting and/or delamination of the stack can take place. Due to the hermetic encapsulation the gas cannot escape.

[0030] In order to solve this problem a hydrogen trap 19 is arranged inside the layer stack 13, 14, 15, 17, at a position in physical connection with the organic (polymer) layer 13.

[0031] In the Fig. 2 embodiment a hydrogen permeable layer 18 is arranged in a position where it is in physical contact with upper electrode 15 and in physical contact with hydrogen getter 19. Via pinholes in the electrode layer 15 and via the hydrogen permeable layer 18, hydrogen getter 19 is in physical connection with polymer layer 13. Accumulation of produced hydrogen at a single place in the getter layer is prevented by spreading the hydrogen over a large surface via the hydrogen permeable layer 18.

[0032] Layer 18 can be any material which is permeable to hydrogen gas. A very special example for layer 8 is a layer of palladium which is permeable to hydrogen but not to other gases. Other examples of such layer (it can also be combined with palladium) are inorganic oxides, nitrides, etc. (e.g. silicon oxide, aluminum oxide, silicon oxide). Usually during the sputtering or evaporation of these materials layers which are permeable to gases are obtained. Layer 18 can also be an organic material with a high glass transition temperature.

[0033] As a material for the inorganic sealing layer 17 a nitride, an oxynitride a metal-oxide or a metal may be used. It has been found that e.g. a defect free layer of Al can be vacuum deposited to a thickness in the range of 500 - 5000 Å in order to produce a hermetic seal. In the Fig. 2 embodiment a metal sealing layer 17 is used. This necessitates the arrangement of an electrical isolation means 16 between the (metal) sealing layer 17 and the lower electrode layer 14 in order to prevent short circuiting. For the same purpose a layer 20 of electrically insulating material is deposited at least over the exposed portion of upper electrode 15 before inorganic sealing layer 17 is deposited. The electrical isolation materials used can be a low melting glass or a ceramic material.

[0034] Summarizing, the invention relates to an electroluminescent panel comprising:

- a closed casing;
- an organic device received in the casing and defining a plurality of pixels; the organic device including an organic luminescent layer between a lower and an upper electrode layer; and
- a getter means disposed in the casing.

[0035] The getter means is a high capacity getter means by employing alkaline metals and/or alkaline earth metals in the form of non-oxidic compounds or alloys in which they are dispersed on a molecular scale, whereby they are still active reactants with oxygen, hydrogen and water.

[0036] Preferably the getter means comprises a getter material selected from the following groups:

- a) an alloy of at least one alkaline metal or alkaline earth metal with an other metal;
- b) alkaline (earth) metal carbide, alkaline (earth) metal silicide, alkaline (earth) metal nitride;
- c) at least one alkaline (earth) metal intercalated in C, Si, Ge, Sn or Pb.

Claims

1. Electroluminescent panel comprising:

- a closed casing;
- an organic device received in the casing and defining a plurality of pixels; the organic device including an

organic luminescent layer between a lower and an upper electrode layer; and
 - a getter means disposed in the casing, **characterized in that** the getter means includes a non-oxidic compound or alloy comprising at least one alkaline metal or alkaline earth metal element, excluding alkaline metal hydride and alkaline earth metal hydride, dispersed on a molecular scale whereby it is still an active reactant with oxygen, hydrogen and water.

2. Electroluminescent panel as claimed in claim 1,
characterized in that the getter means comprises a getter material selected from the following groups:

- a) an alloy of at least one alkaline metal or alkaline earth metal with an other metal;
- b) alkaline (earth) metal carbide, alkaline (earth) metal silicide, alkaline (earth) metal nitride;
- c) at least one alkaline (earth) metal intercalated in C, Si, Ge, Sn or Pb

3. Electroluminescent panel as claimed in claim 1, wherein the getter material is in the form of particles.

4. Electroluminescent panel as claimed in claim 1, wherein the particles have a size of from 0.01 to 10 microns.

5. Electroluminescent panel as claimed in claim 1, wherein the casing comprises a substrate which supports said organic device, a sealing member disposed above and spaced from said organic device, and a sealing adhesive for bonding said sealing member to said substrate.

6. Electroluminescent panel as claimed in claim 1, wherein the casing comprises a substrate which supports said organic device, a sealing layer positioned to form a laminated structure with said organic device and forming together with the substrate an encapsulation for said organic device.

7. Electroluminescent panel as claimed in claim 6, wherein the getter material is located at a position in physical connection with the organic device.

8. Getter means, including a non-oxidic compound or alloy comprising at least one alkaline metal or alkaline earth metal element, excluding alkaline metal hydride and alkaline earth metal hydride, dispersed on a molecular scale whereby it is still an active reactant with oxygen, hydrogen and water, **characterized in that** the getter means comprises a getter material selected from the following groups:

- a) an alloy of at least one alkaline metal with another metal;
- b) alkaline (earth) metal carbide, alkaline (earth) metal silicide, alkaline (earth) metal nitride;
- c) at least one alkaline (earth) metal intercalated in C, Si, Ge, Sn or Pb.

Patentansprüche

1. Elektrolumineszierendes Panel, umfassend:

- ein geschlossenes Gehäuse;
- eine organische Einrichtung, die in dem Gehäuse aufgenommen ist und mehrere Pixel definiert, wobei die organische Einrichtung eine organische lumineszierende Schicht zwischen einer unteren und einer oberen Elektrodenschicht beinhaltet; und
- ein Gettermittel, das im Gehäuse angeordnet ist, **dadurch gekennzeichnet, dass** das Gettermittel eine nichtoxidische Verbindung oder Legierung beinhaltet, die mindestens ein Alkalimetall- oder Erdalkalimetallement umfasst, Alkalimetallhydrid und Erdalkalimetallhydrid ausgeschlossen, das in einem molekularen Maßstab dispergiert ist, wobei es dennoch ein aktiver Reaktant mit Sauerstoff, Wasserstoff und Wasser ist.

2. Elektrolumineszierendes Panel nach Anspruch 1,

dadurch gekennzeichnet, dass das Gettermittel ein Gettermaterial umfasst, das aus den folgenden Gruppen ausgewählt ist:

- a) eine Legierung aus mindestens einem Alkalimetall oder Erdalkalimetall mit einem anderen Metall;

- b) (Erd-)Alkalimetallcarbid,
(Erd-)Alkalimetallsilicid,
(Erd-)Alkalimetallnitrid;
- c) mindestens ein (Erd-)Alkalimetall, das in C, Si, Ge, Sn oder Pb interkaliert ist.

- 5
3. Elektrolumineszierendes Panel nach Anspruch 1, wobei das Gettermaterial in der Form von Partikeln ist.
4. Elektrolumineszierendes Panel nach Anspruch 1, wobei die Partikel eine Größe von 0,01 bis 10 Mikrometern aufweisen.
- 10
5. Elektrolumineszierendes Panel nach Anspruch 1, wobei das Gehäuse ein Substrat, das die organische Einrichtung trägt, ein Abdichtelement, das über und in einem Abstand von der organischen Einrichtung angeordnet ist, und ein Abdichthafmittel zum Kleben des Abdichtelements an das Substrat umfasst.
- 15
6. Elektrolumineszierendes Panel nach Anspruch 1, wobei das Gehäuse umfasst ein Substrat, das die organische Einrichtung trägt, eine Abdichtschicht, die derart positioniert ist, dass sie eine laminierte Struktur mit der organischen Einrichtung bildet, und zusammen mit dem Substrat eine Kapselung für die organische Einrichtung bildet.
- 20
7. Elektrolumineszierendes Panel nach Anspruch 6, wobei das Gettermaterial sich an einer Stelle befindet, an der es in physikalischer Verbindung mit der organischen Einrichtung steht.
8. Gettermittel, das eine nichtoxidische Verbindung oder Legierung beinhaltet, die mindestens ein Alkalimetall- oder Erdalkalimetallelement umfasst, Alkalimetallhydrid und Erdalkalimetallhydrid ausgeschlossen, das in einem molekularen Maßstab dispergiert ist, wobei es dennoch ein aktiver Reaktant mit Sauerstoff, Wasserstoff und Wasser ist, **dadurch gekennzeichnet, dass** das Gettermittel ein Gettermaterial umfasst, das aus den folgenden Gruppen ausgewählt ist:
- 25

- a) eine Legierung aus mindestens eines Alkalimetalls mit einem anderen Metall;
- b) (Erd-)Alkalimetallcarbid, (Erd-)Alkalimetallsilicid, (Erd-)Alkalimetallnitrid;
- c) mindestens ein (Erd-)Alkalimetall, das in C, Si, Ge, Sn oder Pb interkaliert ist.

30

Revendications

- 35
1. Panneau électroluminescent comprenant:

un boîtier fermé;

40

- un dispositif organique étant incorporé dans le boîtier et définissant une pluralité de pixels; le dispositif organique comprenant une couche luminescente organique entre une couche inférieure et une couche supérieure d'électrodes; et

45

- des moyens de getter qui sont disposés dans le boîtier, **caractérisé en ce que** les moyens de getter comprennent un composé ou un alliage non oxydique comprenant au moins un élément métallique alcalin ou un élément métallique alcalino-terreux, excluant de l'hydrure métallique alcalin et de l'hydrure métallique alcalino-terreux, qui est dispersé à une échelle moléculaire, cas dans lequel celui-ci est toujours un réactant actif avec de l'oxygène, de l'hydrogène et de l'eau.

50

2. Panneau électroluminescent selon la revendication 1, **caractérisé en ce que** les moyens de getter comprennent un matériau de getter qui est sélectionné parmi les groupes suivants:

- a) un alliage constitué d'au moins un métal alcalin ou d'un métal alcalino-terreux avec un autre métal;
- b) du carbure métallique alcalino(-terreux),
du siliciure métallique alcalino(-terreux),
- 55 du nitrure métallique alcalino(-terreux);
- c) au moins un métal alcalino(-terreux) étant intercalé dans C, Si, Ge, Sn ou Pb.

3. Panneau électroluminescent selon la revendication 1, dans lequel le matériau de getter se présente sous la forme

de particules.

4. Panneau électroluminescent selon la revendication 1, dans lequel les particules présentent une grosseur dans la gamme comprise entre 0,01 et 10 microns.

5

5. Panneau électroluminescent selon la revendication 1, dans lequel le boîtier comprend un substrat qui supporte ledit dispositif organique, un organe d'étanchéité qui est disposé au-dessus et qui est espacé dudit dispositif organique et un adhésif de scellement pour lier ledit organe d'étanchéité audit substrat.

10 6. Panneau électroluminescent selon la revendication 1, dans lequel le boîtier comprend un substrat qui supporte ledit dispositif organique, une couche de scellement étant déposée de manière à constituer une structure stratifiée avec ledit dispositif organique et qui constitue conjointement avec le substrat un enrobage pour ledit dispositif organique.

15 7. Panneau électroluminescent selon la revendication 6, dans lequel le matériau de getter se situe dans une position en contact physique avec le dispositif organique.

20 8. Moyens de getter comprenant un composé ou un alliage non oxydique comprenant au moins un élément constitué de métal alcalin ou de métal alcalino-terreux, excluant de l'hydrure métallique alcalin et de l'hydrure métallique alcalino-terreux, qui est dispersé à une échelle moléculaire, cas dans lequel que celui-ci est toujours un réactant avec de l'oxygène, de l'hydrogène et de l'eau, ce qui est **caractérisé en ce que** les moyens de getter comprennent un matériau de getter qui est sélectionné parmi les groupes suivants:

20

a) un alliage constitué d'au moins un métal alcalin avec un autre métal;

25

b) du carbure métallique alcalino(-terreux), du siliciure métallique alcalino(-terreux), du nitrure métallique alcalino(-terreux);

c) au moins un métal alcalino(-terreux) étant intercalé dans C, Si, Ge, Sn ou Pb.

30

35

40

45

50

55

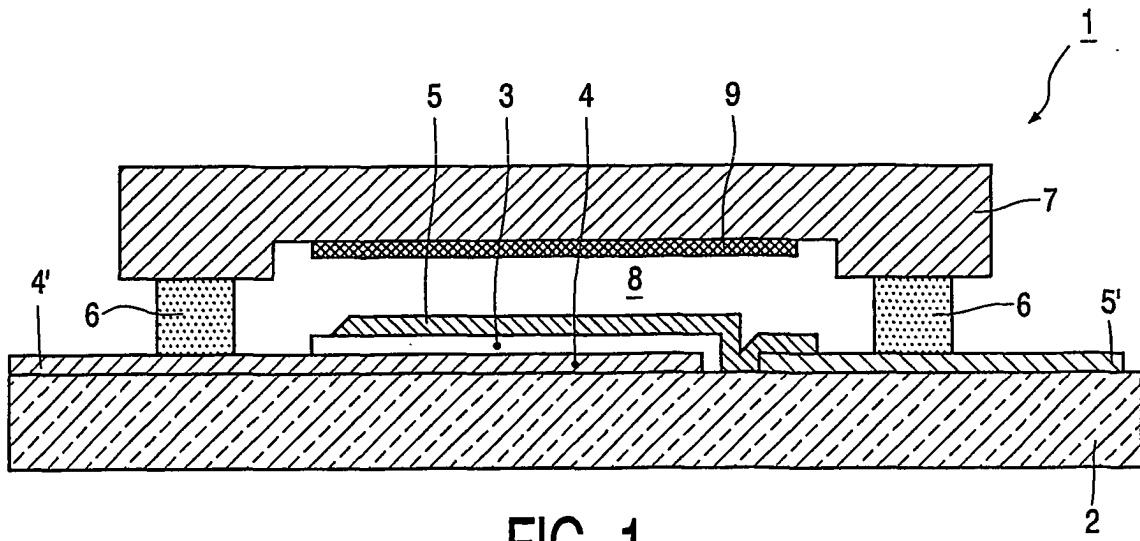

FIG. 1

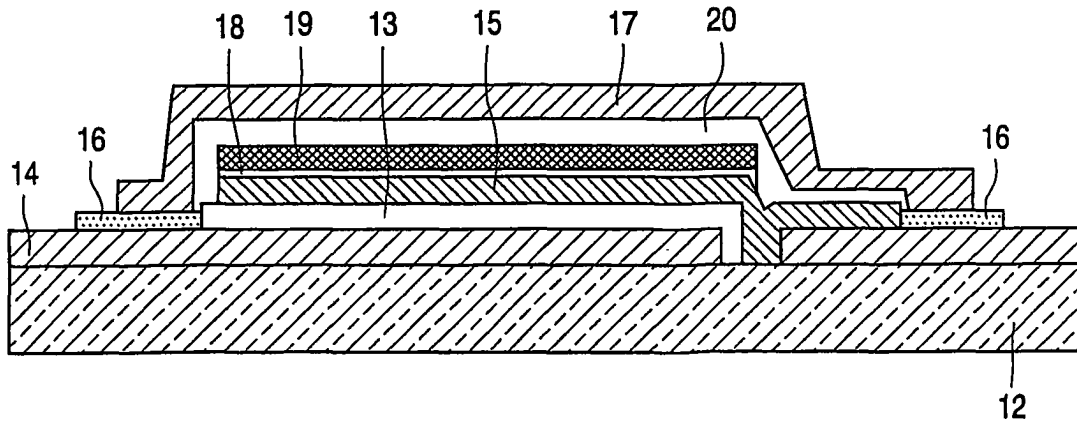

FIG. 2

专利名称(译)	电致发光板		
公开(公告)号	EP1506693B1	公开(公告)日	2006-09-27
申请号	EP2003715192	申请日	2003-04-17
[标]申请(专利权)人(译)	皇家飞利浦电子股份有限公司		
申请(专利权)人(译)	皇家飞利浦电子N.V.		
当前申请(专利权)人(译)	皇家飞利浦电子N.V.		
[标]发明人	HIKMET RIFAT A M VAN HAL HENRICUS A M HASKAL ELIAV I		
发明人	HIKMET, RIFAT, A., M. VAN HAL, HENRICUS, A., M. HASKAL, ELIAV, I.		
IPC分类号	H05B33/04 H01L51/50 H01L51/52		
CPC分类号	H01L51/5259 H01L51/5253 Y10S428/917 Y10T428/239 Y10T428/258		
优先权	2002076847 2002-05-10 EP		
其他公开文献	EP1506693A1		
外部链接	Espacenet		

摘要(译)

一种电致发光面板，包括：封闭的外壳；有机装置容纳在壳体中并限定多个像素；有机器件包括在下电极层和上电极层之间的有机发光层；吸气装置设置在壳体内。吸气装置是一种高容量吸气装置，它采用非氧化物或合金形式的碱金属和/或碱土金属，它们以分子尺度分散，因此它们仍然是与氧，氢和氧的活性反应物。水。优选地，吸气装置包括选自以下组的吸气材料：(a)至少一种碱金属或碱土金属与其它金属的合金；(b)碱(土)金属碳化物，碱(土)金属硅化物，碱(土)金属氮化物；(c)至少一种嵌入C，Si，Ge，Sn或Pb的碱(土)金属。

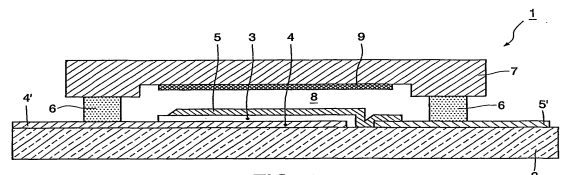

FIG. 1

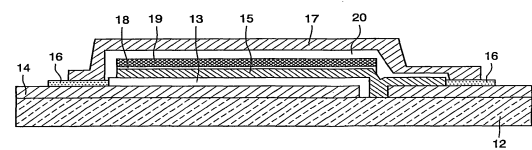

FIG. 2