



(11) **EP 1 445 757 B1**

(12) **EUROPEAN PATENT SPECIFICATION**

(45) Date of publication and mention of the grant of the patent:
15.10.2008 Bulletin 2008/42

(21) Application number: **02758869.8**

(22) Date of filing: **22.08.2002**

(51) Int Cl.:
G09G 3/32^(2006.01)

(86) International application number:
PCT/JP2002/008484

(87) International publication number:
WO 2003/042965 (22.05.2003 Gazette 2003/21)

(54) **ORGANIC EL PANEL DRIVE CIRCUIT**

ANSTEUERSCHALTUNG FÜR EINE ORGANISCHE EL-TAFEL

CIRCUIT DE COMMANDE DE PANNEAU ELECTROLUMINESCENT ORGANIQUE

(84) Designated Contracting States:
DE FR GB IT

(30) Priority: **16.11.2001 JP 2001350872**

(43) Date of publication of application:
11.08.2004 Bulletin 2004/33

(73) Proprietor: **NIPPON SEIKI CO., LTD.**
Nagaoka-shi,
Niigata 940-8580 (JP)

(72) Inventors:
• **MARUYAMA, J.,**
R & D Center of Nippon seiki Co. Ltd
Nagaoka-shi,
Niigata 940-2141 (JP)

• **SUZUKI, A.,**
R & D Center of Nippon seiki Co. Ltd
Nagaoka-shi,
Niigata 940-2141 (JP)

(74) Representative: **Jackson, Richard Eric et al**
Carpmaels & Ransford
43 Bloomsbury Square
London WC1A 2RA (GB)

(56) References cited:
EP-A- 1 291 838 **JP-A- 11 305 729**
JP-A- 2000 214 824 **US-A- 5 594 463**
US-B1- 6 201 520

EP 1 445 757 B1

Note: Within nine months of the publication of the mention of the grant of the European patent in the European Patent Bulletin, any person may give notice to the European Patent Office of opposition to that patent, in accordance with the Implementing Regulations. Notice of opposition shall not be deemed to have been filed until the opposition fee has been paid. (Art. 99(1) European Patent Convention).

Description

Technical Field

[0001] The present invention relates to a drive circuit for an organic EL panel provided with organic EL devices of a dot matrix type.

Background Art

[0002] As an organic EL panel provided with organic EL devices serving as constant current drive devices, there is, for example, one described in JP-A-2001-142432. This is an organic EL panel of a dot matrix type in which plural anode electrode lines using a conductive transparent film such as an ITO (Indium Tin Oxide) are formed in parallel with each other on a translucent insulating support substrate such as a glass substrate, an organic layer (organic EL layer) is formed on the back of these anode electrode lines, plural parallel cathode electrode lines using a metal evaporated film such as aluminum is formed on the back of this organic layer so as to be perpendicular to the anode electrode lines, and the organic layer is held by these anode electrode lines and cathode electrode lines. The organic EL panel has been attracting attentions as a display, which is capable of realizing low power consumption, high display quality, and reduced thickness, substituting a liquid crystal display.

[0003] As a drive circuit for such an organic EL panel, there is one shown in Fig. 6. Such a drive circuit includes an organic EL panel 1, a cathode side drive circuit 2, an anode side drive circuit 3, and a control unit 4.

[0004] The organic EL panel 1 is formed by disposing organic EL devices E11 to Enm bearing pixels in a lattice shape. In a structure of these organic EL devices E11 to Enm, an organic layer including at least a light-emitting layer is held in crossing parts of plural anode electrode lines 1A, which are provided so as to be laid along a vertical direction, and plural cathode electrode lines 1B, which are provided so as to be perpendicular to the anode electrode lines 1A. If represented as an equivalent circuit, the organic EL devices E11 to Enm are formed with one ends thereof connected to the anode electrode lines 1A (anode side of a diode component) and the other ends connected to the cathode electrode lines 1B (cathode side of a diode component).

[0005] The cathode side drive circuit 2 is provided with plural scanning switches 2a1 to 2am corresponding to the respective cathode electrode lines 1B and selects a reverse bias voltage Vb, which becomes a power supply voltage on the cathode side in the respective organic EL devices E11 to Enm, or a ground potential (0V) with the scanning switches 2a1 to 2am based upon a control signal of the control unit 4. That is, the organic EL devices E11 to Enm come into a non-light emitting state when the reverse bias voltage Vb is selected by the scanning switches 2a1 to 2am and come into a light emitting state

when the ground potential is selected by the scanning switches 2a1 to 2am.

[0006] The anode side drive circuit 3 is provided with constant current sources 3a1 to 3an, which supply a constant current (drive current) to the anode electrode lines 1A, respectively, in association with them, and is constituted such that the constant current from these constant current sources 3a1 to 3an is supplied to the respective anode electrode lines 1A via the respective drive switches 3b1 to 3bn. Changeover of the respective drive switches 3b1 to 3bn is determined based upon a control signal from the control unit 4.

[0007] The control unit 4 includes a microcomputer and, for example, when travel information of a vehicle is inputted from various sensors, in an attempt to perform predetermined arithmetic operation processing and to display various kinds of information such as a vehicle speed, an engine speed, and residual fuel on the organic EL panel 1, outputs the travel information to the cathode side drive circuit 2 and the anode side drive circuit 3, respectively, as a control signal, and selectively turns ON/OFF the scanning switches 2a1 to 2am and the drive switches 3b1 to 3bn corresponding to the cathode electrode and anode electrode lines 1B, 1A necessary for causing the organic EL devices E11 to Enm to emit light, thereby causing the organic EL panel 1 to display predetermined information. The drive circuit of the organic EL panel comprises the above portions.

[0008] In such a drive circuit of the organic EL panel 1, gradation control is performed which is based upon pulse width modulation (PWM) of the cathode and anode scanning lines 1B, 1A corresponding to the scanning switches 2a1 to 2am and the drive switches 3b1 to 3bn in the cathode side drive circuit 2 and the anode side drive circuit 3, and the organic EL devices E11 to Enm bearing pixels are driven by the reverse bias voltage (output voltage) Vb, which is a non-selected/selected voltage in the cathode side drive circuit 2, and an output current from the constant current sources 3a1 to 3an in the anode side drive circuit 3.

[0009] However, in the organic EL devices E11 to Enm which have temperature dependency making it possible to emit light with a smaller drive voltage as temperature rises, in order to eliminate reactive power consumed in the anode side drive circuit 3, the organic EL devices E11 to Enm have to be controlled such that a drive voltage is reduced as an ambient temperature rises and that the drive voltage is increased as the ambient temperature falls.

[0010] In addition, there is a problem as described below. If the reverse bias voltage Vb in the cathode side drive circuit 2 suitable for the ambient temperature is not given to the organic EL devices E11 to Enm, in gradation control for one scanning line (light intensity control for one period based upon PWM) in the organic EL device E11 to Enm emitting light by the reverse bias voltage (output voltage) Vb and the output voltage of the constant current sources 3a1 to 3an, the reverse bias voltage Vb

on the cathode side becomes larger than a light emission start voltage (drive voltage of an organic EL device suitable for an ambient temperature) in the organic EL devices E11 to Enm. When the reverse bias voltage V_b is selected by the scanning switches 2a1 to 2am in the cathode side drive circuit 2 in this state, in an organic EL device coupled to the selected cathode electrode line 1B, a charging current is generated by a capacitor component included in the organic EL device. Thus, the reverse bias voltage V_b reaches a light emission voltage concurrently with sharp rising, and light exceeding a predetermined luminance is emitted, although this occurs only in an instance. Note that, although influence of the light emission luminance exceeding the predetermined luminance in the organic EL devices E11 to Enm is relatively inconspicuous if a current application time from the constant current sources 3a1 to 3an by the gradation control is long, the influence becomes more conspicuous as the current application time is shortened by the gradation control.

[0011] EP 1 291 838 A1, which comprises part of the state of the art under Art. 54(3) and (4) EPC for Germany, France and the United Kingdom, discloses the preamble of claim 1 for these countries.

[0012] JP 2000-214824 discloses the preamble of claim 1 for Italy.

[0013] US 5,594,463 discloses a driving circuit for a display apparatus which includes: a driving device for supplying a constant current driving signal to signal electrodes in correspondence with an input signal, to drive a display panel; a detection device for detecting a voltage drop in a forward direction of an EL element, and outputting a detection signal which indicates the detected voltage drop; and a control device for controlling voltage, which is supplied to the driving device, to have a predetermined voltage value in correspondence with the detection signal from the detection device.

[0014] US 6,201,520 B1 discloses a method for driving an organic thin-film EL display by first zero biasing by short-circuiting all pixels and then forward biasing selected pixels and reverse biasing non-selected pixels to prevent crosstalk.

[0015] The present invention has been devised in view of the above-mentioned problem and provides a drive circuit for an organic EL panel capable of controlling generation of reactive power even in the case in which an ambient temperature changes and, at the same time, keeping a light emission luminance of an organic EL device bearing pixels constant.

Disclosure of the Invention

[0016] The present invention provides a drive circuit for an organic EL panel as recited in the claims.

[0017] Therefore, in the cathode side in the organic EL panel, since it becomes possible to give a second temperature compensation drive voltage, which becomes a proper drive voltage according to an ambient tempera-

ture, to the cathode electrode means, it becomes possible to suppress generation of a light emission luminance exceeding a predetermined luminance as in the past. Thus, it becomes possible to suppress a change in luminance with respect to temperature change of organic EL devices bearing pixels, and it is possible to obtain satisfactory display on an organic EL panel and marketability can be improved.

10 Brief Description of the Drawings

[0018] Fig. 1 is a block diagram showing a drive circuit for an organic EL panel of this embodiment, Fig. 2 is a graph showing a temperature voltage characteristic of the organic EL panel of this embodiment, Fig. 3 is a graph showing a temperature voltage characteristic following an offset amount of the organic EL panel of this embodiment, Fig. 4 is a diagram showing second temperature compensation means in the drive circuit of this embodiment, and Fig. 5 is a diagram showing another second temperature compensation means of this embodiment, Fig. 6 is a block diagram showing a conventional drive circuit for an organic EL panel.

25 Best Mode for Carrying Out the Invention

[0019] An embodiment of the present invention will be hereinafter described based upon the accompanying drawings. Parts identical with or equivalent to those in the conventional example are denoted by identical reference numerals, and detailed descriptions of the parts will be omitted.

[0020] As shown in Fig. 1, a drive circuit in this embodiment comprises an organic EL panel 1, a cathode side drive circuit 2, an anode side drive circuit 3, a control unit 4, first temperature compensation means 5, and second temperature compensation means 6.

[0021] In the organic EL panel 1, plural anode electrode lines (first electrode lines) 1A and cathode electrode lines (second electrode lines) 1B are disposed in which the anode electrode lines 1A and the cathode electrode lines 1B are perpendicular (crossing) with each other, and an organic layer including at least a light-emitting layer is held in these crossing parts to constitute organic light-emitting devices E11 to Enm.

[0022] The cathode side drive circuit 2 selects a reverse bias voltage V_B , which becomes a power supply voltage on a cathode side and is generated by the second temperature compensation means 6 described in detail later, or a ground potential with scanning switches 2a1 to 2am.

[0023] The anode side drive circuit 3 is provided with constant current sources 3a1 to 3an for each anode electrode line 1 and selectively applies an output current (constant current) from the constant current sources 3a1 to 3an to the anode electrode lines 1A via respective drive switches 3b1 to 3bn.

[0024] The control unit 4 outputs a control signal to the

cathode side drive circuit 2 and the anode side drive circuit 3, respectively, in an attempt to drive organic EL devices E11 to Enm in the organic EL panel 1, selectively turns ON/OFF the scanning switches 2a1 to 2am and the drive switches 3b1 to 3bn of the cathode electrode and anode electrode lines 1B, 1A, and causes the organic EL devices E11 to Enm bearing pixels to emit light to thereby display various kinds of information.

[0025] The first temperature compensation means 5 is provided with temperature detection means 5a which consists of a thermistor for detecting a change in ambient temperature as a change in resistance value, and a power supply circuit 5b which supplies a first temperature compensation voltage (first temperature compensation voltage) VA obtained by fluctuating a drive voltage (power supply voltage) in the first temperature compensation means 5 in accordance with an output in the temperature detection means 5a, that is, the change in ambient temperature to the constant current sources 3a1 to 3an, thereby supplying a constant current to the respective anode electrode lines 1A via the drive switches 3b1 to 3bn. Note that the power supply circuit 5b is a well-known circuit which comprises, for example, a booster circuit for raising an original power supply voltage to obtain a drive voltage, a driver IC, and the like.

[0026] Fig. 2 shows a first temperature compensation characteristic T1 indicating a relation between the first temperature compensation drive voltage VA, which is supplied from the anode side drive circuit 3 to the organic EL panel 1, and an ambient temperature (-30 degrees Celsius to 85 degrees Celsius). The first temperature compensation means 5 generates the first temperature compensation drive voltage VA following the first temperature compensation characteristic T1 based upon an output from the temperature detection means 5a. Note that it is assumed that the first temperature compensation drive voltage VA changes, for example, within a range of 25V to 16V according to an ambient temperature.

[0027] The second temperature compensation means 6 sets the first temperature compensation voltage VA generated by the first temperature compensation means 5 as a power supply voltage and generates a second temperature compensation voltage VB to be a reverse bias voltage in the cathode side drive circuit 2. That is, as shown in Fig. 3, the second temperature compensation means 6 sets the second temperature compensation voltage VB, which is based upon a second temperature voltage characteristic T2 having a predetermined offset amount x (first temperature compensation drive voltage V - offset voltage) with respect to the first temperature voltage characteristic T1, as a reverse bias voltage (power supply voltage) VB of the cathode side drive circuit 2. Note that, in the case in which the offset amount x is assumed to be, for example, 3V with respect to the first temperature compensation drive voltage VA, when the first temperature compensation drive voltage VA in the first temperature voltage characteristic T1 changes in a range of 25V to 16V, the second temperature compen-

sation drive voltage VB in the second temperature voltage characteristic T2 changes in a range of 22V to 13V.

[0028] The second temperature compensation means 6 has a circuit structure as shown in Fig. 4 in order to obtain the second temperature voltage characteristic T2 having the fixed offset amount x with respect to the first temperature voltage characteristic T1. That is, the second temperature compensation means 6 consists of a power supply output section 6b having offset means 6a in order to obtain the second temperature voltage characteristic T2. The offset means 6a consists of a Zener diode 6a1 and a resistor 6a2 connected in series. The power supply output section 6b comprises an npn transistor 6b1 and electrolytic capacitors 6b2, 6b3. Therefore, one end side of the offset means 6a (cathode side of the Zener diode 6a1) is connected to the drive power supply (first temperature compensation drive voltage) VA and the other end side (resistor 6a2 side) thereof is connected to the ground potential to give a voltage divided by the Zener diode 6a1, and the resistor 6a2 is given as a base voltage of the npn transistor 6b1 in the power supply output section 6b, whereby the second temperature drive voltage VB having the predetermined offset amount x with respect to the first temperature compensation drive voltage VA is obtained. Note that the offset amount x depends upon the Zener diode 6a1 and the resistor 6a2, and fluctuation occurs in the offset amount x by an amount of loss of reactive power due to heat generation of the Zener diode 6a1, the resistor 6a2, components of the power supply output section 6b, or the like. However, if the fluctuation is in a level not affecting a light emission luminance of the organic EL panel 1, the offset amount x is assumed to be a predetermined offset amount x.

[0029] Such a drive circuit for the organic EL panel 1 comprises: drive switches 3b1 to 3bn for selectively applying a constant current to any one of the anode electrode lines 1A; the constant current sources 3a1 to 3an which supply the constant current to the anode electrode lines 1A, respectively, via the drive switches 3b1 to 3bn; the scanning switches 2a1 to 2am for selectively setting any one of the cathode electrode lines 1B to a ground potential and applying the reverse bias voltage VB to the other cathode electrode lines 1B; the first temperature compensation means 5 which is provided with the temperature detection means 5a for detecting an ambient temperature of the organic EL devices E11 to Enm, and generates the first temperature compensation drive voltage VA obtained by changing a power supply voltage according to an output from the temperature detection means 5a and supplies the first temperature compensation drive voltage VA to the constant current sources 3a1 to 3an; and the second temperature compensation means 6 which applies the temperature-compensated second temperature compensation drive voltage VB, which is generated based upon the first temperature compensation drive voltage VA outputted from the first temperature compensation means 5, to the cathode elec-

trode lines 1B via the scanning switches 2a1 to 2am.

[0030] That is, the second temperature compensation means 6 generates the second temperature compensation drive voltage VB, which has the predetermined offset amount x with respect to the first temperature compensation drive voltage VA obtained by the first temperature compensation means 5, with the power supply output section 6b having the offset means 6a which is formed by connecting the Zener diode 6a1 and the resistor 6a2 in series. Therefore, in the cathode side of the organic EL panel 1, since it becomes possible to give the reverse bias voltage (second temperature compensation drive voltage) VB, which becomes a proper drive voltage according to an ambient temperature, to the cathode electrode lines 1B, it becomes possible to suppress generation of a light emission luminance exceeding a predetermined luminance as in the past. Thus, it becomes possible to suppress a change in luminance with respect to temperature change of organic EL devices bearing pixels, and it is possible to obtain satisfactory display on the organic EL panel 1 and marketability can be improved.

[0031] In addition, in the anode side, again, since it becomes possible to supply the first temperature compensation drive voltage VA, which becomes an optimal drive voltage according to an ambient temperature, to the constant current sources 3a1 to 3an in the anode side drive circuit 3, it becomes possible to reduce generation of reactive power of drive devices in the constant current sources 3a1 to 3an following a change in ambient temperature. Thus, since it becomes possible to suppress harmful influence to the anode side drive circuit 3 by heat generation, durability can be improved.

[0032] Fig. 5 shows another embodiment mode in the second temperature compensation means 6. The embodiment mode is different from the above-mentioned embodiment mode in that the second temperature compensation drive voltage (reverse bias voltage) VB is obtained by voltage dividing means 6c instead of the offset means 6a.

[0033] In the second temperature compensation means 6, the respective resistors (at least two resistors) 6c1, 6c2 are connected in series and, at the same time, the first temperature compensation drive voltage VA is divided by the resistor 6c1 and the resistor 6c2, and this voltage obtained by dividing /0 the first temperature compensation drive voltage VA is given as a base voltage of the transistor 6b1, whereby the second temperature compensation drive voltage VB divided at a predetermined ratio with respect to the first temperature compensation drive voltage VA is obtained.

[0034] In such an embodiment mode, the second temperature compensation means 6 generates the second temperature compensation drive voltage VB divided at a predetermined ratio with respect to the first temperature compensation drive voltage VA obtained by the first temperature compensation means 5 (a second temperature voltage characteristic T2' fallen at a predetermined ratio with respect to the first temperature voltage characteristic

T1). In the cathode side of the organic EL panel 1, since it becomes possible to give the reverse bias voltage (second temperature compensation drive voltage) VB, which becomes a proper drive voltage corresponding to an ambient temperature, to the cathode electrode lines 1B, it becomes possible to minimize a change in luminance with respect to temperature change of the organic EL device bearing pixels as in the above-mentioned embodiment mode.

[0035] Note that the second temperature compensation drive voltage VB obtained by dividing the first temperature compensation drive voltage VA depends upon the two resistors 6c1, 6c2, and fluctuation occurs in the second temperature compensation drive voltage VB by an amount of loss of reactive power due to heat generation of the respective resistor 6c1, 6c2, components of the power supply output section 6b, or the like. However, if the fluctuation is in a level not affecting a light emission luminance of the organic EL panel 1, it is assumed that the second temperature compensation drive voltage VB is divided at a predetermined ratio.

Industrial Applicability

[0036] As described above, the drive circuit for an organic EL panel in accordance with the present invention is a drive circuit which is particularly effective in a display panel provided with an organic EL device of a dot matrix type.

Technical Field

[0037] The present invention relates to a drive circuit for an organic EL panel provided with organic EL devices of a dot matrix type.

Background Art

[0038] As an organic EL panel provided with organic EL devices serving as constant current drive devices, there is, for example, one described in JP-A-2001-142432. This is an organic EL panel of a dot matrix type in which plural anode electrode lines using a conductive transparent film such as an ITO (Indium Tin Oxide) are formed in parallel with each other on a translucent insulating support substrate such as a glass substrate, an organic layer (organic EL layer) is formed on the back of these anode electrode lines, plural parallel cathode electrode lines using a metal evaporated film such as aluminum is formed on the back of this organic layer so as to be perpendicular to the anode electrode lines, and the organic layer is held by these anode electrode lines and cathode electrode lines. The organic EL panel has been attracting attentions as a display, which is capable of realizing low power consumption, high display quality, and reduced thickness, substituting a liquid crystal display.

[0039] As a drive circuit for such an organic EL panel,

there is one shown in Fig. 6. Such a drive circuit includes an organic EL panel 1, a cathode side drive circuit 2, an anode side drive circuit 3, and a control unit 4.

[0040] The organic EL panel 1 is formed by disposing organic EL devices E11 to Enm bearing pixels in a lattice shape. In a structure of these organic EL devices E11 to Enm, an organic layer including at least a light-emitting layer is held in crossing parts of plural anode electrode lines 1A, which are provided so as to be laid along a vertical direction, and plural cathode electrode lines 1B, which are provided so as to be perpendicular to the anode electrode lines 1A. If represented as an equivalent circuit, the organic EL devices E11 to Enm are formed with one ends thereof connected to the anode electrode lines 1A (anode side of a diode component) and the other ends connected to the cathode electrode lines 1B (cathode side of a diode component).

[0041] The cathode side drive circuit 2 is provided with plural scanning switches 2a1 to 2am corresponding to the respective cathode electrode lines 1B and selects a reverse bias voltage Vb, which becomes a power supply voltage on the cathode side in the respective organic EL devices E11 to Enm, or a ground potential (0V) with the scanning switches 2a1 to 2am based upon a control signal of the control unit 4. That is, the organic EL devices E11 to Enm come into a non-light emitting state when the reverse bias voltage Vb is selected by the scanning switches 2a1 to 2am and come into a light emitting state when the ground potential is selected by the scanning switches 2a1 to 2am.

[0042] The anode side drive circuit 3 is provided with constant current sources 3a1 to 3an, which supply a constant current (drive current) to the anode electrode lines 1A, respectively, in association with them, and is constituted such that the constant current from these constant current sources 3a1 to 3an is supplied to the respective anode electrode lines 1A via the respective drive switches 3b1 to 3bn. Changeover of the respective drive switches 3b1 to 3bn is determined based upon a control signal from the control unit 4.

[0043] The control unit 4 includes a microcomputer and, for example, when travel information of a vehicle is inputted from various sensors, in an attempt to perform predetermined arithmetic operation processing and to display various kinds of information such as a vehicle speed, an engine speed, and residual fuel on the organic EL panel 1, outputs the travel information to the cathode side drive circuit 2 and the anode side drive circuit 3, respectively, as a control signal, and selectively turns ON/OFF the scanning switches 2a1 to 2am and the drive switches 3b1 to 3bn corresponding to the cathode electrode and anode electrode lines 1B, 1A necessary for causing the organic EL devices E11 to Enm to emit light, thereby causing the organic EL panel 1 to display predetermined information. The drive circuit of the organic EL panel comprises the above portions.

[0044] In such a drive circuit of the organic EL panel 1, gradation control is performed which is based upon

pulse width modulation (PWM) of the cathode and anode scanning lines 1B, 1A corresponding to the scanning switches 2a1 to 2am and the drive switches 3b1 to 3bn in the cathode side drive circuit 2 and the anode side drive circuit 3, and the organic EL devices E11 to Enm bearing pixels are driven by the reverse bias voltage (output voltage) Vb, which is a non-selected/selected voltage in the cathode side drive circuit 2, and an output current from the constant current sources 3a1 to 3an in the anode side drive circuit 3.

[0045] However, in the organic EL devices E11 to Enm which have temperature dependency making it possible to emit light with a smaller drive voltage as temperature rises, in order to eliminate reactive power consumed in the anode side drive circuit 3, the organic EL devices E11 to Enm have to be controlled such that a drive voltage is reduced as an ambient temperature rises and that the drive voltage is increased as the ambient temperature falls.

[0046] In addition, there is a problem as described below. If the reverse bias voltage Vb in the cathode side drive circuit 2 suitable for the ambient temperature is not given to the organic EL devices E11 to Enm, in gradation control for one scanning line (light intensity control for one period based upon PWM) in the organic EL device E11 to Enm emitting light by the reverse bias voltage (output voltage) Vb and the output voltage of the constant current sources 3a1 to 3an, the reverse bias voltage Vb on the cathode side becomes larger than a light emission start voltage (drive voltage of an organic EL device suitable for an ambient temperature) in the organic EL devices E11 to Enm. When the reverse bias voltage Vb is selected by the scanning switches 2a1 to 2am in the cathode side drive circuit 2 in this state, in an organic EL device coupled to the selected cathode electrode line 1B, a charging current is generated by a capacitor component included in the organic EL device. Thus, the reverse bias voltage Vb reaches a light emission voltage concurrently with sharp rising, and light exceeding a predetermined luminance is emitted, although this occurs only in an instance. Note that, although influence of the light emission luminance exceeding the predetermined luminance in the organic EL devices E11 to Enm is relatively inconspicuous if a current application time from the constant current sources 3a1 to 3an by the gradation control is long, the influence becomes more conspicuous as the current application time is shortened by the gradation control.

[0047] EP 1 291 838 A1, which comprises part of the state of the art under Art. 54(3) and (4) EPC for Germany, France and the United Kingdom, discloses the preamble of claim 1 for these countries.

[0048] JP 2000-214824 discloses the preamble of claim 1 for Italy.

[0049] US 5,594,463 discloses a driving circuit for a display apparatus which includes: a driving device for supplying a constant current driving signal to signal electrodes in correspondence with an input signal, to drive a

display panel; a detection device for detecting a voltage drop in a forward direction of an EL element, and outputting a detection signal which indicates the detected voltage drop; and a control device for controlling voltage, which is supplied to the driving device, to have a predetermined voltage value in correspondence with the detection signal from the detection device.

[0050] US 6,201,520 B1 discloses a method for driving an organic thin-film EL display by first zero biasing by short-circuiting all pixels and then forward biasing selected pixels and reverse biasing non-selected pixels to prevent crosstalk.

[0051] The present invention has been devised in view of the above-mentioned problem and provides a drive circuit for an organic EL panel capable of controlling generation of reactive power even in the case in which an ambient temperature changes and, at the same time, keeping a light emission luminance of an organic EL device bearing pixels constant.

Disclosure of the Invention

[0052] The present invention provides a drive circuit for an organic EL panel as recited in the claims.

[0053] Therefore, in the cathode side in the organic EL panel, since it becomes possible to give a second temperature compensation drive voltage, which becomes a proper drive voltage according to an ambient temperature, to the cathode electrode means, it becomes possible to suppress generation of a light emission luminance exceeding a predetermined luminance as in the past. Thus, it becomes possible to suppress a change in luminance with respect to temperature change of organic EL devices bearing pixels, and it is possible to obtain satisfactory display on an organic EL panel and marketability can be improved.

Brief Description of the Drawings

[0054] Fig. 1 is a block diagram showing a drive circuit for an organic EL panel of this embodiment, Fig. 2 is a graph showing a temperature voltage characteristic of the organic EL panel of this embodiment, Fig. 3 is a graph showing a temperature voltage characteristic following an offset amount of the organic EL panel of this embodiment, Fig. 4 is a diagram showing second temperature compensation means in the drive circuit of this embodiment, and Fig. 5 is a diagram showing another second temperature compensation means of this embodiment, Fig. 6 is a block diagram showing a conventional drive circuit for an organic EL panel.

Best Mode for Carrying Out the Invention

[0055] An embodiment of the present invention will be hereinafter described based upon the accompanying drawings. Parts identical with or equivalent to those in the conventional example are denoted by identical ref-

erence numerals, and detailed descriptions of the parts will be omitted.

[0056] As shown in Fig. 1, a drive circuit in this embodiment comprises an organic EL panel 1, a cathode side drive circuit 2, an anode side drive circuit 3, a control unit 4, first temperature compensation means 5, and second temperature compensation means 6.

[0057] In the organic EL panel 1, plural anode electrode lines (first electrode lines) 1A and cathode electrode lines (second electrode lines) 1B are disposed in which the anode electrode lines 1A and the cathode electrode lines 1B are perpendicular (crossing) with each other, and an organic layer including at least a light-emitting layer is held in these crossing parts to constitute organic light-emitting devices E11 to Enm.

[0058] The cathode side drive circuit 2 selects a reverse bias voltage VB, which becomes a power supply voltage on a cathode side and is generated by the second temperature compensation means 6 described in detail later, or a ground potential with scanning switches 2a1 to 2am.

[0059] The anode side drive circuit 3 is provided with constant current sources 3a1 to 3an for each anode electrode line 1 and selectively applies an output current (constant current) from the constant current sources 3a1 to 3an to the anode electrode lines 1A via respective drive switches 3b1 to 3bn.

[0060] The control unit 4 outputs a control signal to the cathode side drive circuit 2 and the anode side drive circuit 3, respectively, in an attempt to drive organic EL devices E11 to Enm in the organic EL panel 1, selectively turns ON/OFF the scanning switches 2a1 to 2am and the drive switches 3b1 to 3bn of the cathode electrode and anode electrode lines 1B, 1A, and causes the organic EL devices E11 to Enm bearing pixels to emit light to thereby display various kinds of information.

[0061] The first temperature compensation means 5 is provided with temperature detection means 5a which consists of a thermistor for detecting a change in ambient temperature as a change in resistance value, and a power supply circuit 5b which supplies a first temperature compensation voltage (first temperature compensation voltage) VA obtained by fluctuating a drive voltage (power supply voltage) in the first temperature compensation means 5 in accordance with an output in the temperature detection means 5a, that is, the change in ambient temperature to the constant current sources 3a1 to 3an, thereby supplying a constant current to the respective anode electrode lines 1A via the drive switches 3b1 to 3bn. Note that the power supply circuit 5b is a well-known circuit which comprises, for example, a booster circuit for raising an original power supply voltage to obtain a drive voltage, a driver IC, and the like.

[0062] Fig. 2 shows a first temperature compensation characteristic T1 indicating a relation between the first temperature compensation drive voltage VA, which is supplied from the anode side drive circuit 3 to the organic EL panel 1, and an ambient temperature (-30 degrees

Celsius to 85 degrees Celsius). The first temperature compensation means 5 generates the first temperature compensation drive voltage VA following the first temperature compensation characteristic T1 based upon an output from the temperature detection means 5a. Note that it is assumed that the first temperature compensation drive voltage VA changes, for example, within a range of 25V to 16V according to an ambient temperature.

[0063] The second temperature compensation means 6 sets the first temperature compensation voltage VA generated by the first temperature compensation means 5 as a power supply voltage and generates a second temperature compensation voltage VB to be a reverse bias voltage in the cathode side drive circuit 2. That is, as shown in Fig. 3, the second temperature compensation means 6 sets the second temperature compensation voltage VB, which is based upon a second temperature voltage characteristic T2 having a predetermined offset amount x (first temperature compensation drive voltage V - offset voltage) with respect to the first temperature voltage characteristic T1, as a reverse bias voltage (power supply voltage) VB of the cathode side drive circuit 2. Note that, in the case in which the offset amount x is assumed to be, for example, 3V with respect to the first temperature compensation drive voltage VA, when the first temperature compensation drive voltage VA in the first temperature voltage characteristic T1 changes in a range of 25V to 16V, the second temperature compensation drive voltage VB in the second temperature voltage characteristic T2 changes in a range of 22V to 13V.

[0064] The second temperature compensation means 6 has a circuit structure as shown in Fig. 4 in order to obtain the second temperature voltage characteristic T2 having the fixed offset amount x with respect to the first temperature voltage characteristic T1. That is, the second temperature compensation means 6 consists of a power supply output section 6b having offset means 6a in order to obtain the second temperature voltage characteristic T2. The offset means 6a consists of a Zener diode 6a1 and a resistor 6a2 connected in series. The power supply output section 6b comprises an npn transistor 6b1 and electrolytic capacitors 6b2, 6b3. Therefore, one end side of the offset means 6a (cathode side of the Zener diode 6a1) is connected to the drive power supply (first temperature compensation drive voltage) VA and the other end side (resistor 6a2 side) thereof is connected to the ground potential to give a voltage divided by the Zener diode 6a1, and the resistor 6a2 is given as a base voltage of the npn transistor 6b1 in the power supply output section 6b, whereby the second temperature drive voltage VB having the predetermined offset amount x with respect to the first temperature compensation drive voltage VA is obtained. Note that the offset amount x depends upon the Zener diode 6a1 and the resistor 6a2, and fluctuation occurs in the offset amount x by an amount of loss of reactive power due to heat generation of the Zener diode 6a1, the resistor 6a2, components of the power supply output section 6b, or the

like. However, if the fluctuation is in a level not affecting a light emission luminance of the organic EL panel 1, the offset amount x is assumed to be a predetermined offset amount x.

[0065] Such a drive circuit for the organic EL panel 1 comprises : drive switches 3b1 to 3bn for selectively applying a constant current to any one of the anode electrode lines 1A; the constant current sources 3a1 to 3an which supply the constant current to the anode electrode lines 1A, respectively, via the drive switches 3b1 to 3bn; the scanning switches 2a1 to 2am for selectively setting any one of the cathode electrode lines 1B to a ground potential and applying the reverse bias voltage VB to the other cathode electrode lines 1B; the first temperature compensation means 5 which is provided with the temperature detection means 5a for detecting an ambient temperature of the organic EL devices E11 to Enm, and generates the first temperature compensation drive voltage VA obtained by changing a power supply voltage according to an output from the temperature detection means 5a and supplies the first temperature compensation drive voltage VA to the constant current sources 3a1 to 3an; and the second temperature compensation means 6 which applies the temperature-compensated second temperature compensation drive voltage VB, which is generated based upon the first temperature compensation drive voltage VA outputted from the first temperature compensation means 5, to the cathode electrode lines 1B via the scanning switches 2a1 to 2am.

[0066] That is, the second temperature compensation means 6 generates the second temperature compensation drive voltage VB, which has the predetermined offset amount x with respect to the first temperature compensation drive voltage VA obtained by the first temperature compensation means 5, with the power supply output section 6b having the offset means 6a which is formed by connecting the Zener diode 6a1 and the resistor 6a2 in series. Therefore, in the cathode side of the organic EL panel 1, since it becomes possible to give the reverse bias voltage (second temperature compensation drive voltage) VB, which becomes a proper drive voltage according to an ambient temperature, to the cathode electrode lines 1B, it becomes possible to suppress generation of a light emission luminance exceeding a predetermined luminance as in the past. Thus, it becomes possible to suppress a change in luminance with respect to temperature change of organic EL devices bearing pixels, and it is possible to obtain satisfactory display on the organic EL panel 1 and marketability can be improved.

[0067] In addition, in the anode side, again, since it becomes possible to supply the first temperature compensation drive voltage VA, which becomes an optimal drive voltage according to an ambient temperature, to the constant current sources 3a1 to 3an in the anode side drive circuit 3, it becomes possible to reduce generation of reactive power of drive devices in the constant current sources 3a1 to 3an following a change in ambient temperature. Thus, since it becomes possible to sup-

press harmful influence to the anode side drive circuit 3 by heat generation, durability can be improved.

[0068] Fig. 5 shows another embodiment mode in the second temperature compensation means 6. The embodiment mode is different from the above-mentioned embodiment mode in that the second temperature compensation drive voltage (reverse bias voltage) VB is obtained by voltage dividing means 6c instead of the offset means 6a.

[0069] In the second temperature compensation means 6, the respective resistors (at least two resistors) 6c1, 6c2 are connected in series and, at the same time, the first temperature compensation drive voltage VA is divided by the resistor 6c1 and the resistor 6c2, and this voltage obtained by dividing the first temperature compensation drive voltage VA is given as a base voltage of the transistor 6b1, whereby the second temperature compensation drive voltage VB divided at a predetermined ratio with respect to the first temperature compensation drive voltage VA is obtained.

[0070] In such an embodiment mode, the second temperature compensation means 6 generates the second temperature compensation drive voltage VB divided at a predetermined ratio with respect to the first temperature compensation drive voltage VA obtained by the first temperature compensation means 5 (a second temperature voltage characteristic T2' fallen at a predetermined ratio with respect to the first temperature voltage characteristic T1). In the cathode side of the organic EL panel 1, since it becomes possible to give the reverse bias voltage (second temperature compensation drive voltage) VB, which becomes a proper drive voltage corresponding to an ambient temperature, to the cathode electrode lines 1B, it becomes possible to minimize a change in luminance with respect to temperature change of the organic EL device bearing pixels as in the above-mentioned embodiment mode.

[0071] Note that the second temperature compensation drive voltage VB obtained by dividing the first temperature compensation drive voltage VA depends upon the two resistors 6c1, 6c2, and fluctuation occurs in the second temperature compensation drive voltage VB by an amount of loss of reactive power due to heat generation of the respective resistor 6c1, 6c2, components of the power supply output section 6b, or the like. However, if the fluctuation is in a level not affecting a light emission luminance of the organic EL panel 1, it is assumed that the second temperature compensation drive voltage VB is divided at a predetermined ratio.

Industrial Applicability

[0072] As described above, the drive circuit for an organic EL panel in accordance with the present invention is a drive circuit which is particularly effective in a display panel provided with an organic EL device of a dot matrix type.

Claims

Claims for the following Contracting State(s): DE, FR, GB

1. A drive circuit for an organic EL panel (1) which is provided with a plurality of first and second electrode lines (1A, 1B), at least one of which is translucent, and in which an organic layer including at least a light-emitting layer is held between the respective electrode lines to constitute an organic EL devices (E11 - Enm) of a dot matrix shape, comprising:

anode scanning means (3b1 - 3bn) for selectively applying a constant current to any one of the first electrode lines (1A);

a constant current source (3a1 - 3an) which supplies the constant current to one of the first electrode lines (1A) via the anode scanning means (3b1 - 3bn);

cathode scanning means (2) for selectively setting any one of the second electrode lines (1B) to a ground potential and applying a reverse bias voltage (VB) to the other second electrode lines (1B);

first temperature compensation means (5) which is provided with temperature detection means (5a) for detecting an ambient temperature of the organic EL devices (E11 - Enm), and generates a first temperature compensation drive voltage (VA) obtained by changing a power supply voltage according to an output from the temperature detection means (5a) and supplies the first temperature compensation drive voltage (VA) to the constant current source (3a1 - 3an); and

second temperature compensation means (6) which applies a temperature-compensated second temperature compensation drive voltage (VB), which is generated based upon the first temperature compensation drive voltage (VA) outputted from the first temperature compensation means (5), to the second electrode lines (1B) as the reverse bias voltage via the cathode scanning means (2); and wherein

the second temperature compensation means (6) generates the second temperature compensation drive voltage (VB) which has a predetermined offset amount with respect to the first temperature compensation drive voltage (VA) obtained by the first temperature compensation means (5), **characterised in that:** the second temperature compensation means (6) determines the offset amount with offset means (6a) which is formed by connecting a Zener diode (6a1) and a resistor (6a2) in series.

Claims for the following Contracting State(s): IT

1. A drive circuit for an organic EL panel (1) which is provided with a plurality of first and second electrode lines (1A, 1B), at least one of which is translucent, and in which an organic layer including at least a light-emitting layer is held between the respective electrode lines to constitute an organic EL devices (E11 - Enm) of a dot matrix shape, comprising:

anode scanning means (3b1 - 3bn) for selectively applying a constant current to any one of the first electrode lines (1A);

a constant current source (3a1 - 3an) which supplies the constant current to one of the first electrode lines (1A) via the anode scanning means (3b1 - 3bn);

cathode scanning means (2) for selectively setting any one of the second electrode lines (1B) to a ground potential and applying a reverse bias voltage (VB) to the other second electrode lines (1B); and **characterised by:**

first temperature compensation means (5) which is provided with temperature detection means (5a) for detecting an ambient temperature of the organic EL devices (E11 - Enm), and generates a first temperature compensation drive voltage (VA) obtained by changing a power supply voltage according to an output from the temperature detection means (5a) and supplies the first temperature compensation drive voltage (VA) to the constant current source (3a1 - 3an); and

second temperature compensation means (6) which applies a temperature-compensated second temperature compensation drive voltage (VB), which is generated based upon the first temperature compensation drive voltage (VA) outputted from the first temperature compensation means (5), to the second electrode lines (1B) as the reverse bias voltage via the cathode scanning means (2).

2. A drive circuit for an organic EL panel according to claim 1, **characterized in that** the second temperature compensation means (6) generates the second temperature compensation drive voltage (VB) which has a predetermined offset amount with respect to the first temperature compensation drive voltage (VA) obtained by the first temperature compensation means (5).
3. A drive circuit for an organic EL panel according to claim 2, **characterized in that** the second temperature compensation means (6) determines the offset

amount with offset means (6a) which is formed by connecting a Zener diode (6a1) and a resistor (6a2) in series.

4. A drive circuit for an organic EL panel according to claim 1, **characterized in that** the second temperature compensation means (6) applies the second temperature compensation voltage (VB) of a predetermined ratio with respect to the first temperature compensation drive voltage (VA) obtained by the first temperature compensation means (5) to the second electrode lines (1B) via the cathode scanning means (2).

5. A drive circuit for an organic EL panel according to claim 4, **characterized in that** the second temperature compensation means (6) is provided with voltage dividing means formed by connecting at least two resistors (6c1, 6c2) in series and generates the second temperature compensation drive voltage (VB) divided at a predetermined ratio with respect to the first temperature compensation drive voltage (VA) by the voltage dividing means.

Patentansprüche**Patentansprüche für folgende(n) Vertragsstaat(en): DE, FR, GB**

1. Ansteuerschaltung für eine organische EL-Tafel (1), die mit mehreren ersten und zweiten Elektrodenleitungen (1A, 1B) versehen ist, von denen mindestens eine durchscheinend ist, wobei eine organische Schicht, die mindestens eine Licht aussendende Schicht enthält, zwischen den jeweiligen Elektrodenleitungen gehalten wird, um organische EL-Bauelemente (E11 - Enm) einer Punktmatrixform zu bilden, umfassend:

Anodenabtastmittel (3b1 - 3bn) zum selektiven Einspeisen eines Konstantstroms in jede der ersten Elektrodenleitungen (1A);

eine Konstantstromquelle (3a1 - 3an), die den Konstantstrom über die Anodenabtastmittel (3b1 - 3bn) in eine der ersten Elektrodenleitungen (1A) einspeist;

Kathodenabtastmittel (2) zum selektiven Einstellen einer jeden der zweiten Elektrodenleitungen (1B) auf ein Erdungspotenzial und Einspeisen einer Sperrvorspannung (VB) in die anderen zweiten Elektrodenleitungen (1B);

ein erstes Temperaturkompensationsmittel (5), das mit einem Temperaturdetektionsmittel (5a) zum Detektieren einer Umgebungstemperatur der organischen EL-Bauelemente (E11 - Enm) versehen ist und eine erste Temperaturkompen-

sations-Ansteuerspannung (VA) erzeugt, die durch Ändern einer Energieversorgungsspannung gemäß einem Ausgangssignal von dem Temperaturdetektionsmittel (5a) erhalten wird, und die erste Temperaturkompensations-Ansteuerspannung (VA) in die Konstantstromquelle (3a1 - 3an) einspeist; und
 ein zweites Temperaturkompensationsmittel (6), das eine temperaturkompensierte zweite Temperaturkompensations-Ansteuerspannung (VB), die auf der Grundlage der ersten Temperaturkompensations-Ansteuerspannung (VA) erzeugt wird, die von dem ersten Temperaturkompensationsmittel (5) ausgegeben wird, über die Kathodenabtastrmittel (2) in die zweiten Elektrodenleitungen (1B) als die Sperrvorspannung einspeist; und wobei
 das zweite Temperaturkompensationsmittel (6) die zweite Temperaturkompensations-Ansteuerspannung (VB) erzeugt, die einen vorgegebenen Versatzbetrag relativ zu der ersten Temperaturkompensations-Ansteuerspannung (VA), die durch das erste Temperaturkompensationsmittel (5) erhalten wird, aufweist, **dadurch gekennzeichnet, dass:**

das zweite Temperaturkompensationsmittel (6) den Versatzbetrag mit einem Versatzmittel (6a) bestimmt, das durch Schalten einer Zener-Diode (6a1) und eines Widerstandes (6a2) in Reihe gebildet wird.

Patentansprüche für folgende(n) Vertragsstaat(en): IT

1. Ansteuerschaltung für eine organische EL-Tafel (1), die mit mehreren ersten und zweiten Elektrodenleitungen (1A, 1B) versehen ist, von denen mindestens eine durchscheinend ist, wobei eine organische Schicht, die mindestens eine Licht aussendende Schicht enthält, zwischen den jeweiligen Elektrodenleitungen gehalten wird, um organische EL-Bauelemente (E11 - Enm) einer Punktmatrixform zu bilden, umfassend:

Anodenabtastrmittel (3b1 - 3bn) zum selektiven Einspeisen eines Konstantstroms in jede der ersten Elektrodenleitungen (1A);
 eine Konstantstromquelle (3a1 - 3an), die den Konstantstrom über die Anodenabtastrmittel (3b1 - 3bn) in eine der ersten Elektrodenleitungen (1A) einspeist:

Kathodenabtastrmittel (2) zum selektiven Einstellen einer jeden der zweiten Elektrodenleitungen (1B) auf ein Erdungspotenzial und Einspeisen einer Sperrvorspannung

(VB) in die anderen zweiten Elektrodenleitungen (1B); und **gekennzeichnet durch:**

ein erstes Temperaturkompensationsmittel (5), das mit einem Temperaturdetektionsmittel (5a) zum Detektieren einer Umgebungstemperatur der organischen EL-Bauelemente (E11 - Enm) versehen ist und eine erste Temperaturkompensations-Ansteuerspannung (VA) erzeugt, die **durch** Ändern einer Energieversorgungsspannung gemäß einem Ausgangssignal von dem Temperaturdetektionsmittel (5a) erhalten wird, und die erste Temperaturkompensations-Ansteuerspannung (VA) in die Konstantstromquelle (3a1 - 3an) einspeist; und

ein zweites Temperaturkompensationsmittel (6), das eine temperaturkompensierte zweite Temperaturkompensations-Ansteuerspannung (VB), die auf der Grundlage der ersten Temperaturkompensations-Ansteuerspannung (VA) erzeugt wird, die von dem ersten Temperaturkompensationsmittel (5) ausgegeben wird, über die Kathodenabtastrmittel (2) in die zweiten Elektrodenleitungen (1B) als die Sperrvorspannung einspeist.

2. Ansteuerschaltung für eine organische EL-Tafel nach Anspruch 1, **dadurch gekennzeichnet, dass** das zweite Temperaturkompensationsmittel (6) die zweite Temperaturkompensations-Ansteuerspannung (VB) erzeugt, die einen vorgegebenen Versatzbetrag relativ zu der ersten Temperaturkompensations-Ansteuerspannung (VA), die durch das erste Temperaturkompensationsmittel (5) erhalten wird, aufweist.
3. Ansteuerschaltung für eine organische EL-Tafel nach Anspruch 2, **dadurch gekennzeichnet, dass** das zweite Temperaturkompensationsmittel (6) den Versatzbetrag mit einem Versatzmittel (6a) bestimmt, das durch Schalten einer Zener-Diode (6a1) und eines Widerstandes (6a2) in Reihe gebildet wird.
4. Ansteuerschaltung für eine organische EL-Tafel nach Anspruch 1, **dadurch gekennzeichnet, dass** das zweite Temperaturkompensationsmittel (6) die zweite Temperaturkompensations-Ansteuerspannung (VB) eines vorgegebenen Verhältnisses relativ zu der ersten Temperaturkompensations-Ansteuerspannung (VA), die durch das erste Temperaturkompensationsmittel (5) erhalten wird, über das Kathodenabtastrmittel (2) in die zweiten Elektrodenleitungen (1B) einspeist.

5. Ansteuerschaltung für eine organische EL-Tafel nach Anspruch 1, **dadurch gekennzeichnet, dass** das zweite Temperaturkompensationsmittel (6) mit einem Spannungsteilungsmittel versehen ist, das durch Schalten von mindestens zwei Widerständen (6c1, 6c2) in Reihe gebildet wird und die zweite Temperaturkompensations-Ansteuerung (VB) erzeugt, die mit einem vorgegebenen Verhältnis relativ zu der ersten Temperaturkompensations-Ansteuerung (VA) durch das Spannungsteilungsmittel geteilt wird.

Revendications

Revendications pour l'(les) Etat(s) contractant(s) suivant(s): DE, FR, GB

1. Circuit de commande pour un panneau électroluminescent organique (1) qui est doté d'une pluralité de premières et de deuxièmes lignes d'électrodes (1A, 1B), dont au moins une est translucide, et dans lequel une couche organique comportant au moins une couche d'émission de lumière est maintenue entre les lignes d'électrodes respectives pour constituer des dispositifs électroluminescents organiques (E11 - Enm) ayant une forme de matrice en point, comprenant :

des moyens de balayage d'anode (3b1 - 3bn) pour appliquer de façon sélective un courant constant sur l'une quelconque des premières lignes d'électrodes (1A) ;
 une source de courant constant (3a1 - 3an) qui achemine le courant constant jusqu'à une des premières lignes d'électrodes (1A) par les moyens de balayage d'anode (3b1 - 3bn) ;
 des moyens de balayage de cathode (2) pour régler de façon sélective l'une quelconque des deuxièmes lignes d'électrodes (1B) sur un potentiel de terre et pour appliquer une tension de polarisation inverse (VB) sur les autres deuxièmes lignes d'électrodes (1B) ;
 des premiers moyens de compensation de température (5) qui sont dotés de moyens de détection de température (5a) pour détecter une température ambiante des dispositifs électroluminescents organiques (E11 - Enm), et génèrent une première tension de commande de compensation de température (VA) obtenue en modifiant une tension d'acheminement d'énergie selon une sortie depuis les moyens de détection de température (5a) et acheminent la première tension de commande de compensation de température (VA) jusqu'à la source de courant constant (3a1 - 3an) ; et
 des deuxièmes moyens de compensation de

température (6) qui appliquent une deuxième tension de commande de compensation de température de température compensée (VB), qui est générée en fonction de la première tension de commande de compensation de température (VA) envoyée depuis les premiers moyens de compensation de température (5), jusqu'aux deuxièmes lignes d'électrodes (1B) telle que la tension de polarisation inverse par les moyens de balayage de cathode (2) ; et dans lequel les deuxièmes moyens de compensation de température (6) génèrent la deuxième tension de commande de compensation de température (VB) qui a une valeur décalée prédéterminée par rapport à la première tension de commande de compensation de température (VA) obtenue par les premiers moyens de compensation de température (5),

caractérisé en ce que les deuxièmes moyens de compensation de température (6) déterminent la valeur décalée à l'aide de moyens de décalage (6a) qui sont formés en connectant une diode Zener (6a1) et une résistance (6a2) en série.

Revendications pour l'(les) Etat(s) contractant(s) suivant(s): IT

1. Circuit de commande pour un panneau électroluminescent organique (1) qui est doté d'une pluralité de premières et de deuxièmes lignes d'électrodes (1A, 1B), dont au moins une est translucide, et dans lequel une couche organique comportant au moins une couche d'émission de lumière est maintenue entre les lignes d'électrodes respectives pour constituer des dispositifs électroluminescents organiques (E11 - Enm) ayant une forme de matrice en point, comprenant :

des moyens de balayage d'anode (3b1 - 3bn) pour appliquer de façon sélective un courant constant sur l'une quelconque des premières lignes d'électrodes (1A) ;
 une source de courant constant (3a1 - 3an) qui achemine le courant constant jusqu'à une des premières lignes d'électrodes (1A) par les moyens de balayage d'anode (3b1 - 3bn) ;
 des moyens de balayage de cathode (2) pour régler de façon sélective l'une quelconque des deuxièmes lignes d'électrodes (1B) sur un potentiel de terre et pour appliquer une tension de polarisation inverse (VB) sur les autres deuxièmes lignes d'électrodes (1B) ; et **caractérisé par :**

des premiers moyens de compensation de température (5) qui sont dotés de moyens

de détection de température (5a) pour détecter une température ambiante des dispositifs électroluminescents organiques (E11 - Enm), et génèrent une première tension de commande de compensation de température (VA) obtenue en modifiant une tension d'acheminement d'énergie selon une sortie depuis les moyens de détection de température (5a) et acheminent la première tension de commande de compensation de température (VA) jusqu'à la source de courant constant (3a1 - 3an) ; et des deuxièmes moyens de compensation de température (6) qui appliquent une deuxième tension de commande de compensation de température de température compensée (VB), qui est générée en fonction de la première tension de commande de compensation de température (VA) envoyée depuis les premiers moyens de compensation de température (5), jusqu'aux deuxièmes lignes d'électrodes (1B) telle que la tension de polarisation inverse par les moyens de balayage de cathode (2).

2. Circuit de commande destiné à un panneau électroluminescent organique selon la revendication 1, **caractérisé en ce que** les deuxièmes moyens de compensation de température (6) génèrent la deuxième tension de commande de compensation de température (VB) qui a une valeur décalée prédéterminée par rapport à la première tension de commande de compensation de température (VA) obtenue par les premiers moyens de compensation de température (5).
3. Circuit de commande destiné à un panneau électroluminescent organique selon la revendication 2, **caractérisé en ce que** les deuxièmes moyens de compensation de température (6) déterminent la valeur décalée avec des moyens de décalage (6a) qui sont formés en connectant une diode Zener (6a1) et une résistance (6a2) en série.
4. Circuit de commande destiné à un panneau électroluminescent organique selon la revendication 1, **caractérisé en ce que** les deuxièmes moyens de compensation de température (6) appliquent la deuxième tension de compensation de température (VB) d'une proportion prédéterminée par rapport à la première tension de commande de compensation de température (VA) obtenue par les premiers moyens de compensation de température (5), aux deuxièmes lignes d'électrodes (1B) par les moyens de balayage de cathode (2).
5. Circuit de commande destiné à un panneau électroluminescent organique selon la revendication 4, **ca-**

ractérisé en ce que les deuxièmes moyens de compensation de température (6) sont dotés de moyens de division de tension formés en connectant au moins deux résistances (6c1, 6c2) en série et génèrent la deuxième tension de commande de compensation de température (VB) divisée à une proportion prédéterminée par rapport à la première tension de commande de compensation de température (VA) par les moyens de division de tension.

FIG. 1

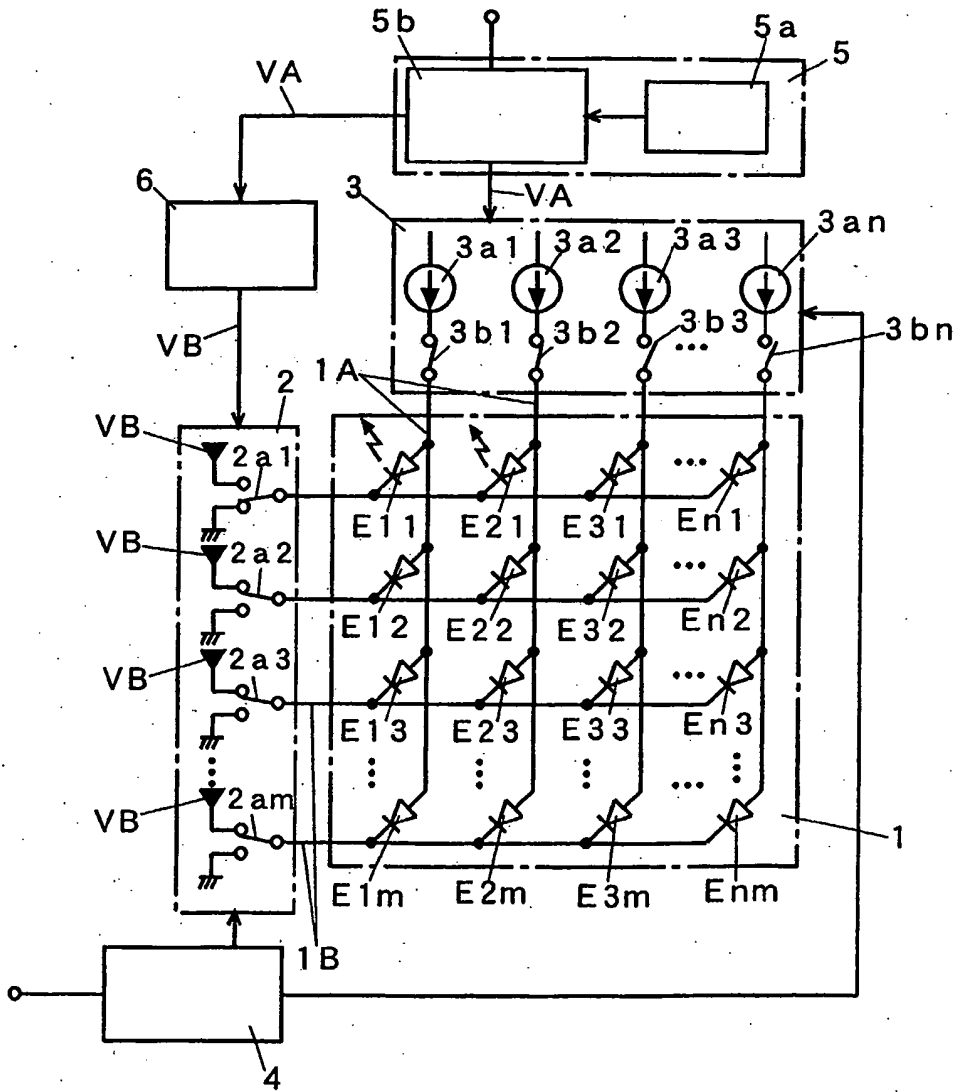

- 4 : CONTROL UNIT
- 5 : FIRST TEMPERATURE COMPENSATION MEANS
- 5a : TEMPERATURE DETECTION MEANS
- 5b : POWER SUPPLY CIRCUIT
- 6 : SECOND TEMPERATURE COMPENSATION MEANS

FIG. 2

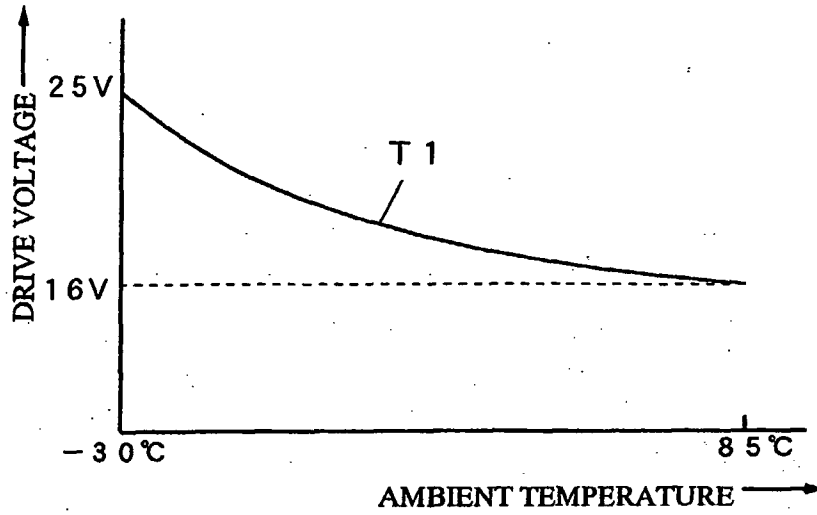

FIG. 3

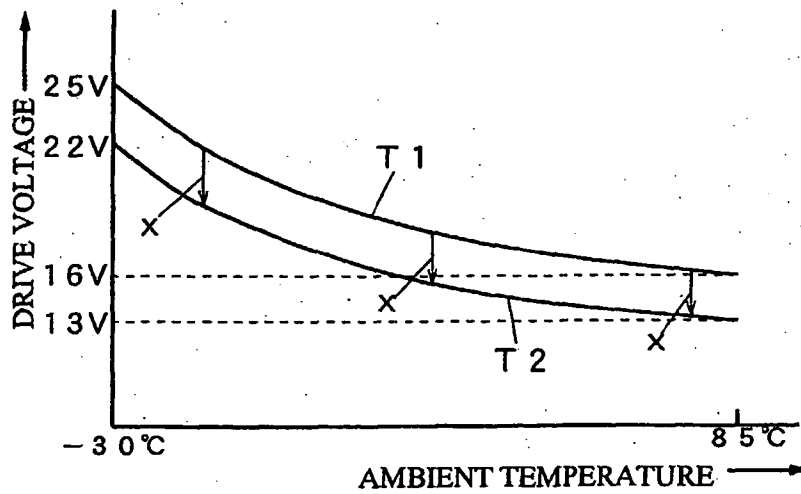

FIG. 4

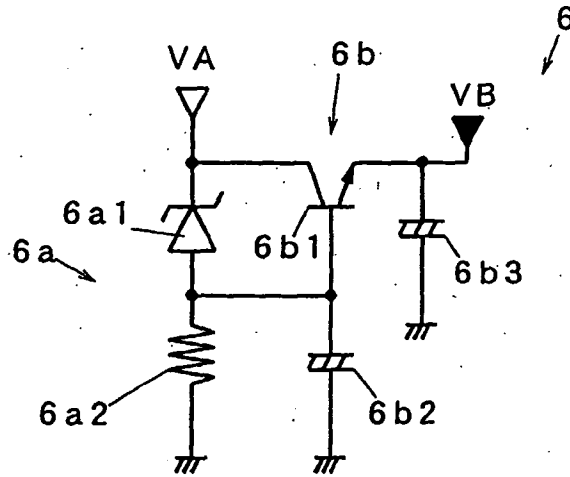

FIG. 5

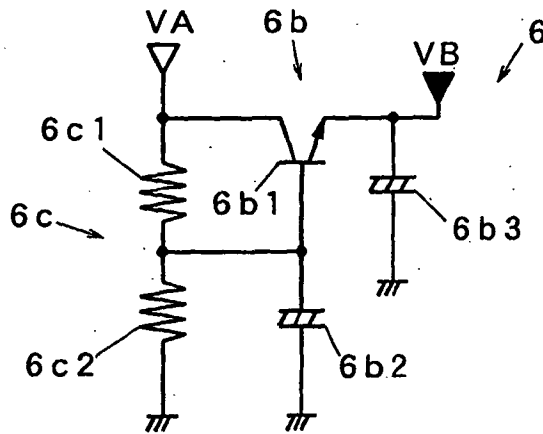
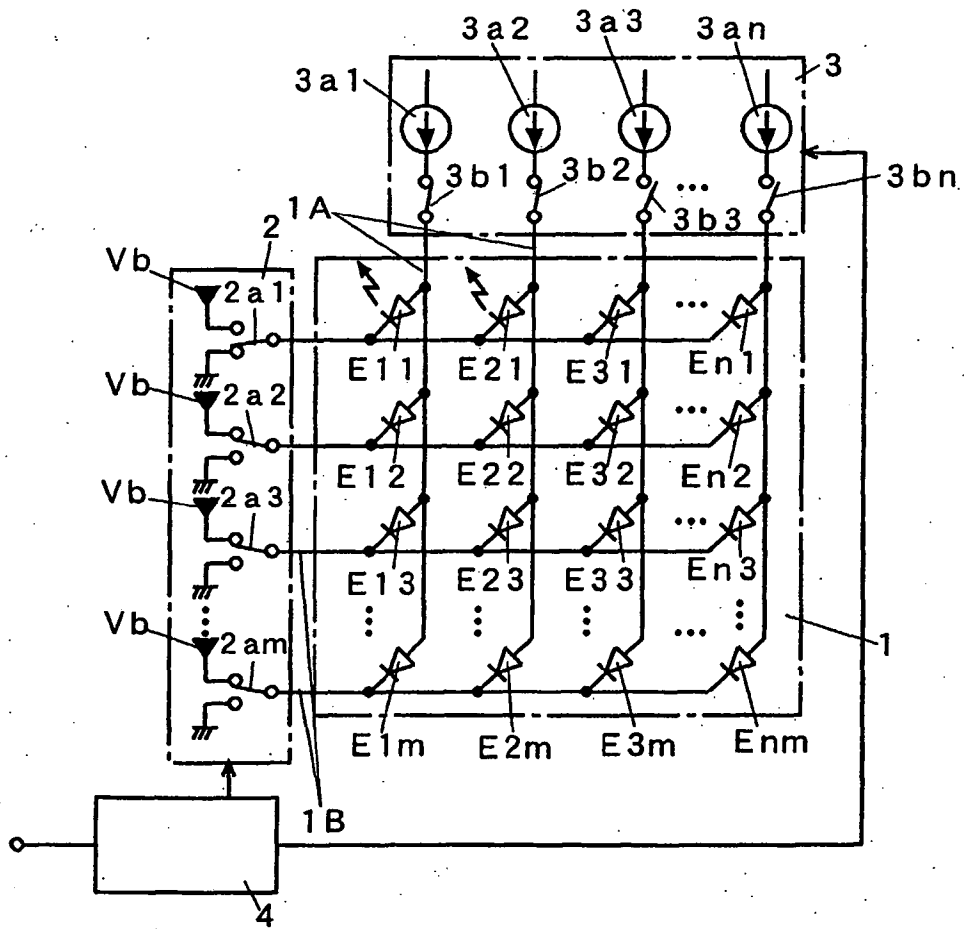

FIG. 6



4 : CONTROL UNIT

REFERENCES CITED IN THE DESCRIPTION

This list of references cited by the applicant is for the reader's convenience only. It does not form part of the European patent document. Even though great care has been taken in compiling the references, errors or omissions cannot be excluded and the EPO disclaims all liability in this regard.

Patent documents cited in the description

- JP 2001142432 A [0002] [0038]
- EP 1291838 A1 [0011] [0047]
- JP 2000214824 A [0012] [0048]
- US 5594463 A [0013] [0049]
- US 6201520 B1 [0014] [0050]

专利名称(译)	有机EL面板驱动电路		
公开(公告)号	EP1445757B1	公开(公告)日	2008-10-15
申请号	EP2002758869	申请日	2002-08-22
[标]申请(专利权)人(译)	日本精机株式会社		
申请(专利权)人(译)	日本精机股份有限公司.		
当前申请(专利权)人(译)	日本精机股份有限公司.		
[标]发明人	MARUYAMA J R & D CENT OF NIPPON SEIKI CO LTD SUZUKI A R & D CENT OF NIPPON SEIKI CO LTD		
发明人	MARUYAMA, J., R & D CENTER OF NIPPON SEIKI CO. LTD SUZUKI, A., R & D CENTER OF NIPPON SEIKI CO. LTD		
IPC分类号	G09G3/32 H01L51/50 G09G3/20 G09G3/30		
CPC分类号	G09G3/3216 G09G2310/0256 G09G2320/029 G09G2320/041 G09G2320/043 G09G2330/028		
优先权	2001350872 2001-11-16 JP		
其他公开文献	EP1445757A1 EP1445757A4		
外部链接	Espacenet		

摘要(译)

驱动开关3b1~3bn向阳极线1A中的任一个选择性地施加恒定电流。恒定电流源3a1~3an经由驱动开关3b1~3bn分别向阳极电极线1A供给恒定电流。扫描开关2a1~2am选择性地将阴极电极线1B中的任一个设定为接地电位，并向其他阴极电极线1B施加反向偏置电压。第一温度补偿装置5设置有用以检测有机EL器件E11至Enm的环境温度的温度检测装置5a，并且产生通过根据温度检测的输出改变电源电压而获得的第一温度补偿驱动电压VA装置5a，并将第一温度补偿驱动电压VA提供给恒流源3a1至3an。第二温度补偿装置6将基于从第一温度补偿装置5输出的第一温度补偿驱动电压VA产生的温度补偿的第二温度补偿驱动电压VB施加到阴极电极线1B作为反向偏置电压扫描开关2a1至2am。

