

(19)



(11)

EP 2 719 741 B1

(12)

EUROPEAN PATENT SPECIFICATION

(45) Date of publication and mention of the grant of the patent:

13.04.2016 Bulletin 2016/15

(51) Int Cl.:

C09K 11/06 <small>(2006.01)</small>	C07D 471/04 <small>(2006.01)</small>
C07F 9/28 <small>(2006.01)</small>	H01L 51/50 <small>(2006.01)</small>
H01L 51/00 <small>(2006.01)</small>	C07D 487/04 <small>(2006.01)</small>
H05B 33/10 <small>(2006.01)</small>	C09B 57/00 <small>(2006.01)</small>

(21) Application number: **12799893.8**

(22) Date of filing: **12.06.2012**

(86) International application number:
PCT/KR2012/004629

(87) International publication number:
WO 2012/173371 (20.12.2012 Gazette 2012/51)

(54) NOVEL COMPOUNDS AND ORGANIC ELECTRONIC DEVICE USING SAME

NEUE VERBINDUNGEN UND DIESE VERWENDENDE ORGANISCHE ELEKTRONISCHE VORRICHTUNG

COMPOSÉS ORIGINAUX ET DISPOSITIF ÉLECTRONIQUE ORGANIQUE UTILISANT CES COMPOSÉS

(84) Designated Contracting States:

AL AT BE BG CH CY CZ DE DK EE ES FI FR GB GR HR HU IE IS IT LI LT LU LV MC MK MT NL NO PL PT RO RS SE SI SK SM TR

- **LEE, Dong Hoon**
Daejeon 301-793 (KR)
- **JANG, Jungi**
Daejeon 305-340 (KR)
- **CHUN, Minseung**
Daejeon 305-390 (KR)

(30) Priority: **13.06.2011 KR 20110056777**

(43) Date of publication of application:
16.04.2014 Bulletin 2014/16

(74) Representative: **Hoffmann Eitle**
Patent- und Rechtsanwälte PartmbB
Arabellastraße 30
81925 München (DE)

(73) Proprietor: **LG Chem, Ltd.**
Seoul 150-721 (KR)

(72) Inventors:

- **SHIN, Changhwan**
Daejeon 302-210 (KR)
- **KIM, Kongkyeom**
Daejeon 305-500 (KR)

(56) References cited:

WO-A1-2007/064479	WO-A1-2007/069847
WO-A1-2007/069847	WO-A1-2009/100991
WO-A2-2011/010842	KR-A- 20050 037 337
KR-A- 20050 037 337	KR-A- 20060 109 524
US-A1- 2005 123 795	US-A1- 2006 269 784

EP 2 719 741 B1

Note: Within nine months of the publication of the mention of the grant of the European patent in the European Patent Bulletin, any person may give notice to the European Patent Office of opposition to that patent, in accordance with the Implementing Regulations. Notice of opposition shall not be deemed to have been filed until the opposition fee has been paid. (Art. 99(1) European Patent Convention).

Description

[Technical Field]

5 **[0001]** The present application claims priority from Korean Patent Application No. 10-2011-0056777, filed on June 13, 2011 at the KIPO.

[0002] The present invention relates to a new compound and an organic electronic device using the same.

[Background Art]

10 **[0003]** In the present specification, an organic electronic device is an electronic device using an organic semiconductor material, and requires exchanging of holes and/or electrons between electrodes and organic semiconductor materials. The organic electronic device may be largely divided into the following two categories according to an operation principle. First, there is an electronic device in which an exciton is formed in an organic material layer by a photon that flows from an external light source to the device, the exciton is separated into electrons and holes, and the electrons and the holes are transferred to the other electrodes, respectively and used as a current source (voltage source). Second, there is an electronic device in which holes and/or electrons are injected into organic semiconductor material layers forming an interface with the electrode by applying a voltage or a current to two or more electrodes, and the device is operated by the injected electrons and holes.

20 **[0004]** As examples of the organic electronic device, there are an organic light emitting device, an organic solar cell, an organic photoconductor (OPC) drum, an organic transistor and the like, and an electron/hole injection material, an electron/hole extraction material, an electron/hole transporting material or a light emitting material is required in order to drive all these devices.

25 **[0005]** Hereinafter, an organic light emitting device will be mainly described in detail. However, in the organic electronic devices, all of the electron/hole injection material, the electron/hole extraction material, the electron/hole transporting material and the light emitting material are operated based on a similar principle.

30 **[0006]** In general, an organic light emitting phenomenon refers to a phenomenon that converts electric energy into light energy by using an organic material. The organic light emitting device using the organic light emitting phenomenon has a structure which typically comprises an anode, a cathode, and an organic material layer that is disposed therebetween. Herein, organic material layers frequently have a multilayer structure that comprises different materials in order to enhance efficiency and stability of the organic light emitting device, and for example, and may comprise a hole injection layer, a hole transporting layer, a light emitting layer, an electron transporting layer, an electron injection layer and the like. In the structure of the organic light emitting device, if a voltage is applied between two electrodes, holes are injected from an anode into the organic material layer and electrons are injected from a cathode into the organic material layer, and when the injected holes and the electrons meet each other, an exciton is formed, and light is emitted when the exciton falls to a bottom state. It is known that this organic light emitting device has properties such as self light emission, high brightness, high efficiency, low driving voltage, a wide viewing angle, high contrast, high speed response and the like.

35 **[0007]** In the organic light emitting device, the material that is used as the organic material layer may be classified into a light emitting material and an electric charge transporting material, for example, a hole injection material, a hole transporting material, an electron transporting material, an electron injection material and the like according to a function thereof. Examples of the light emitting material include blue, green, and red light emitting materials and yellow and orange light emitting materials required for realizing better natural colors according to the emission color. In addition, in order to increase color purity and increase light emission efficiency through energy transfer, a host/dopant system may be used as the light emitting material. In the principle, by mixing a dopant that has an energy bandwidth gap that is lower than that of a host mainly constituting the light emitting layer and has excellent light emission efficiency with a light emitting layer in a small amount, an exciton that is generated in the host is transported to the dopant to produce light having high efficiency. At this time, since the wavelength of the host moves to the wavelength bandwidth of the dopant, light at a desired wavelength may be obtained according to the kind of dopant used.

40 **[0008]** In order to sufficiently show excellent properties of the above-described organic light emitting device, a material constituting the organic material layer in the device, for example, a hole injection material, a hole transporting material, a light emitting material, an electron transporting material, the electron injection material and the like need to be mainly supported by stable and efficient materials, but the development of a stable and efficient organic material layer material for organic light emitting device has not been sufficiently achieved. Accordingly, there is a continuous need for developing a new material

55 **[0009]** The following documents are considered relevant prior art:

WO 2007/069847 and WO 2011/010842 both recite imidazoquinazoline derivatives for use in light emitting devices; KR 2006/0109524 recites phosphine-oxide substituted aromatic compounds for use in electron-transport or light-

emitting layers of a light emitting device.

[Detailed Description of the Invention]

5 [Technical Problem]

[0010] The present inventors have found out a compound having a new structure. In addition, the inventors have found out the fact that when an organic material layer of an organic electron device is formed by using the new compound, effects such as an increase in efficiency of the device, a drop in driving voltage, an increase in stability and the like can be obtained.

10 [0011] Thus, an object of the present invention is to provide a new compound and an organic electronic device using the same.

[Technical Solution]

15

[0012] The present invention provides a compound represented by the following Formula 1.

[Formula 1]

20

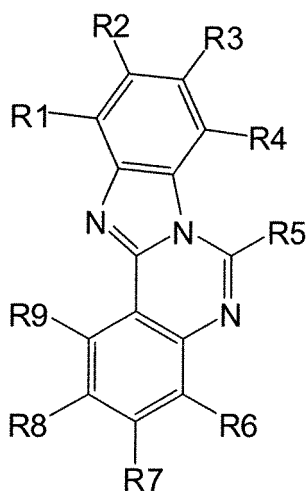

25

30

35

wherein

at least one of R1 to R9 is represented by the following Formula 2 and the rest thereof are hydrogen; deuterium; a halogen group; a nitrile group; a nitro group; a hydroxyl group; a substituted or unsubstituted cycloalkyl group; a substituted or unsubstituted alkoxy group; a substituted or unsubstituted aryloxy group; a substituted or unsubstituted alkylthioxy group; a substituted or unsubstituted arylthioxy group; a substituted or unsubstituted alkylsulfoxy group; a substituted or unsubstituted arylsulfoxy group; a substituted or unsubstituted alkenyl group; a substituted or unsubstituted silyl group; a substituted or unsubstituted boron group; a substituted or unsubstituted alkylamine group; a substituted or unsubstituted aralkylamine group; a substituted or unsubstituted arylamine group; a substituted or unsubstituted heteroarylamine group; a substituted or unsubstituted aryl group; a substituted or unsubstituted fluorenyl group; a substituted or unsubstituted carbazole group; or a substituted or unsubstituted heterocyclic group comprising one or more of N, O, and S atoms; and

50

[Formula 2]

55

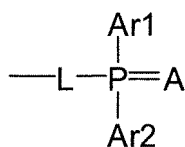

L is a direct bond; a substituted or unsubstituted arylene group; or a substituted or unsubstituted heteroarylene

group comprising one or more of N, O and S atoms,

Ar1 and Ar2 are each independently a substituted or unsubstituted aryl group; or a substituted or unsubstituted heterocyclic group comprising one or more of N, O and S atoms; and

A is O, S or Se.

5

[0013] In addition, the present invention provides an organic electron device comprising a first electrode, a second electrode, and one or more organic material layers disposed between the first electrode and the second electrode, wherein one or more layers of the organic material layers comprise a compound represented by Formula 1.

10 [Advantageous Effects]

[0014] The new compound according to the present invention may be used as a material for an organic material layer of an organic electronic device comprising an organic light emitting device by introducing various substituent groups and the like. The organic electronic device comprising an organic light emitting device using the compound represented by Formula 1 according to the present invention as a material for an organic material layer shows excellent properties in terms of efficiency, driving voltage, service life and the like.

15

[Brief Description of Drawings]

20 **[0015]**

FIG. 1 illustrates a structure of an organic light emitting device in which an anode 102, a light emitting layer 105, and a cathode 107 are sequentially stacked on a substrate 101.

25

FIG. 2 illustrates a structure of an organic light emitting device in which an anode 102, a hole injection/hole transporting and light emitting layer 105, an electron transporting layer 106 and a cathode 107 are sequentially stacked on a substrate 101.

FIG. 3 illustrates a structure of an organic light emitting device in which a substrate 101, an anode 102, a hole injection layer 103, a hole transporting and light emitting layer 105, an electron transporting layer 106 and a cathode 107 are sequentially stacked.

30

FIG. 4 illustrates a structure of an organic light emitting device in which a substrate 101, an anode 102, a hole injection layer 103, a hole transporting layer 104, an electron transporting and light emitting layer 105 and a cathode 107 are sequentially stacked.

[Best Mode]

35

[0016] Hereinafter, the present invention will be described in more detail.

[0017] A new compound according to the present invention is represented by Formula 1.

[0018] In Formula 1, R5 may be represented by Formula 2, but is not limited thereto.

40

[0019] In the compound according to the present invention, the substituent groups in Formula 1 will be described in more detail as follows.

[0020] The alkyl group may be straight or branched, and the number of carbon atoms thereof is not particularly limited, but is preferably 1 to 12. Specific examples thereof include a methyl group, an ethyl group, a propyl group, an isopropyl group, a butyl group, a t-butyl group, a pentyl group, a hexyl group, a heptyl group and the like, but are not limited thereto.

45

[0021] The alkenyl group may be straight or branched, and the number of carbon atoms thereof is not particularly limited, but is preferably 2 to 12. Specific examples thereof include an alkenyl group linked with an aryl group such as a stylybenyl group, a styrenyl group and the like, but are not limited thereto.

[0022] The alkynyl group may be straight or branched, and the number of carbon atoms thereof is not particularly limited, but is preferably 2 to 12. Specific examples thereof include an ethynyl group, a propynyl group and the like, but are not limited thereto.

50

[0023] The cycloalkyl group is preferably a group having 3 to 12 carbon atoms, which does not cause a steric hindrance. Specific examples thereof include a cyclopentyl group, a cyclohexyl group and the like, but are not limited thereto.

[0024] The cycloalkenyl group preferably has 3 to 12 carbon atoms, and more specific examples thereof include a ring compound having ethenylene in a pentagonal or hexagonal ring, and the like, but are not limited thereto.

55

[0025] The alkoxy group preferably has 1 to 12 carbon atoms, and more specific examples thereof include methoxy, ethoxy, isopropoxy and the like, but are not limited thereto.

[0026] The aryloxy group preferably has 6 to 20 carbon atoms, and more specific examples thereof include phenyloxy, cyclohexyloxy, naphthyloxy, diphenyloxy and the like, but are not limited thereto.

[0027] The alkylamine group preferably has 1 to 30 carbon atoms, and more specific examples thereof include a

methylamine group, a dimethylamine group, an ethylamine group, a diethylamine group and the like, but are not limited thereto.

[0028] The arylamine group preferably has 5 to 30 carbon atoms, and more specific examples thereof include a phenylamine group, a naphthylamine group, a biphenylamine group, an anthracenylamine group, a 3-methyl-phenylamine group, a 4-methyl-naphthylamine group, a 2-methyl-biphenylamine group, a 9-methyl-anthracenylamine group, a diphenylamine group, a phenyl-naphthylamine group, a ditolylamine group, a phenyltolylamine group, a triphenylamine group and the like, but are not limited thereto.

[0029] The aryl group may be monocyclic or polycyclic, and the number of carbon atoms thereof is not particularly limited, but is preferably 6 to 40. Examples of the monocyclic aryl group include a phenyl group, a biphenyl group, a terphenyl group, stilbene and the like, and examples of the polycyclic aryl group include a naphthyl group, an anthracenyl group, a phenanthrene group, a pyrenyl group, a perylenyl group, a chrysenyl group, a fluorenyl group, and the like, but are not limited thereto.

[0030] The heteroaryl group is a ring group comprising O, N, S, or P as a heterogeneous atom, and the number of carbon atoms is not particularly limited, but is preferably 3 to 30. Examples of the heterocyclic group include a carbazole group, a thiophene group, a furan group, a pyrrole group, an imidazole group, a thiazole group, an oxazole group, an oxadiazole group, a triazole group, a pyridyl group, a pyridazine group, a quinolinyl group, an isoquinoline group, an acridyl group and the like, and compounds having the following structural formulas are preferred, but are not limited thereto.

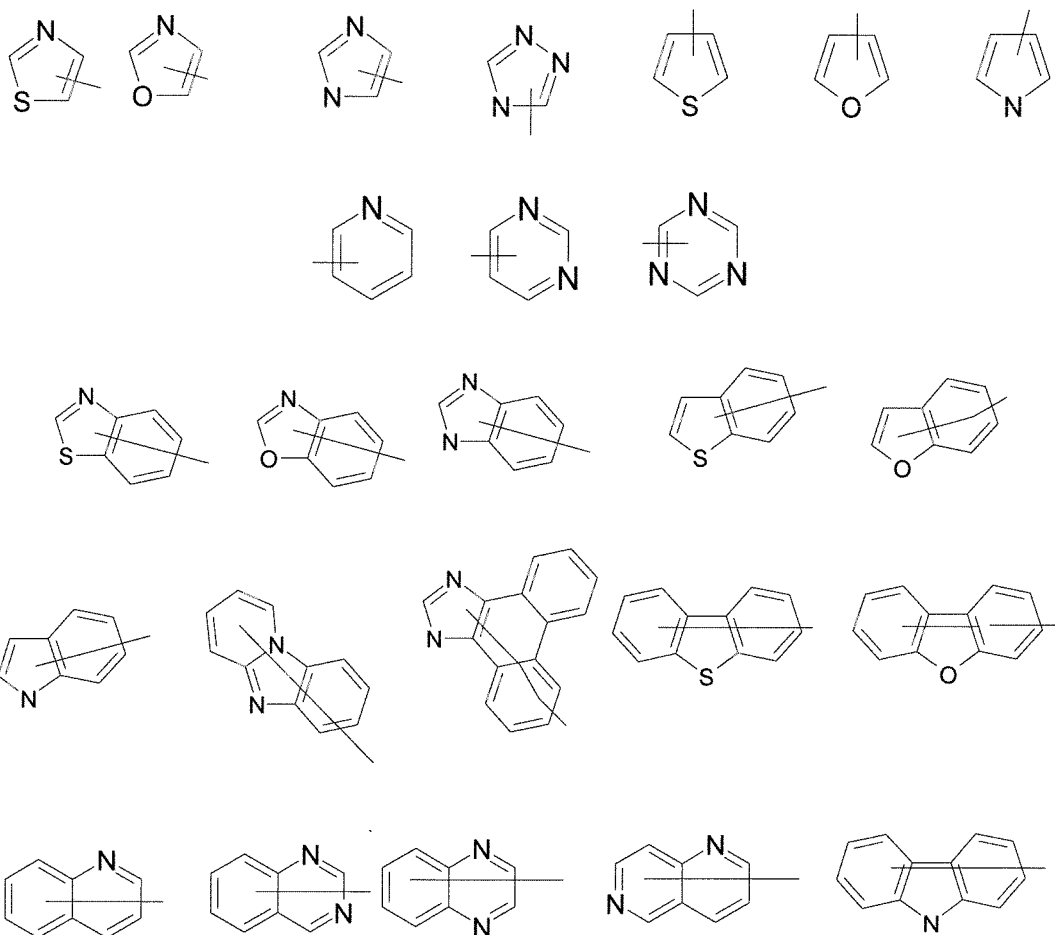

[0031] Examples of the halogen group include fluorine, chlorine, bromine, iodine and the like, but are not limited thereto.

[0032] Specific examples of the arylene group include a phenylene group, a biphenylene group, a naphthalene group, a binaphthalene group, an anthracenylene group, a fluorenylene group, a chrysenylene group, a phenanthrenylene group and the like, but are not limited thereto.

[0033] Examples of the heterocycloalkyl group include a ring group comprising a heterogeneous element such as N, S or O.

[0034] Further, as used herein, the term "substituted or unsubstituted" means that a group is substituted with one or

more substituent groups selected from the group consisting of deuterium, a halogen group, an alkyl group, an alkenyl group, an alkoxy group, a silyl group, an arylalkenyl group, an aryl group, a heteroaryl group, a carbazole group, an arylamine group, a fluorenyl group which is unsubstituted or substituted with an aryl group, and a nitrile group, or has no substituent group.

5 **[0035]** R1 to R9 in Formula 1, L, Ar1, Ar2 and A may be further substituted with an additional substituent group, and examples thereof include a halogen group, an alkyl group, an alkenyl group, an alkoxy group, a silyl group, an arylalkenyl group, an aryl group, a heteroaryl group, a carbazole group, an arylamine group, a fluorenyl group which is unsubstituted or substituted with an aryl group, a nitrile group, and the like, but are not limited thereto.

10 **[0036]** Preferred specific examples of the compound represented by Formula 1 comprise the following compounds, but are not limited thereto.

[Formula 1-1]

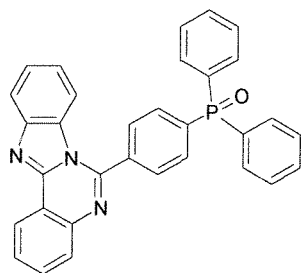

[Formula 1-2]

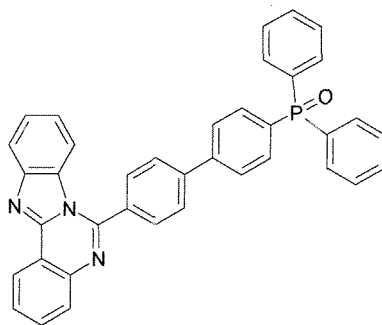

[Formula 1-3]

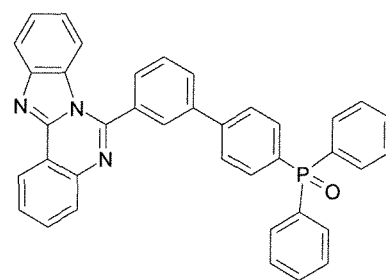

[Formula 1-4]

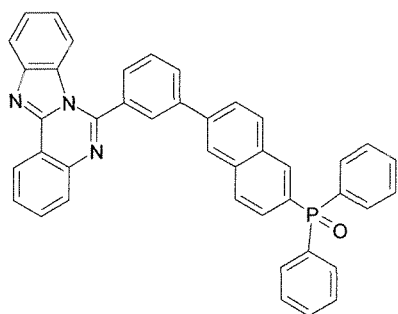

[Formula 1-5]

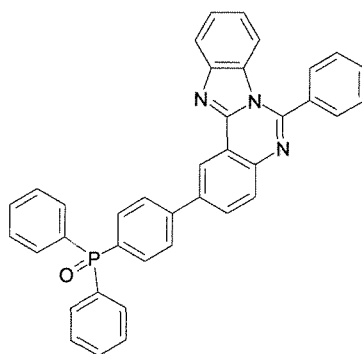

[Formula 1-6]

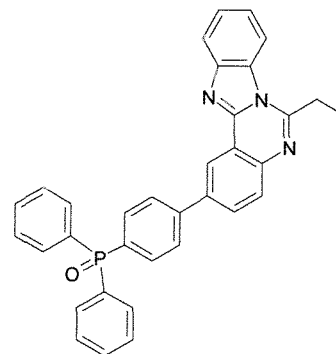

[Formula 1-7]

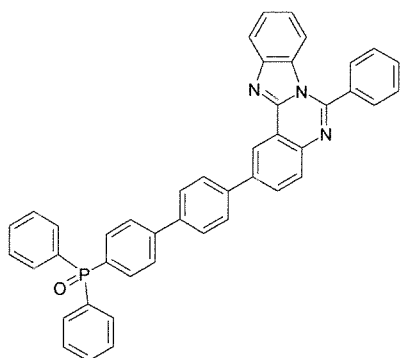

[Formula 1-8]

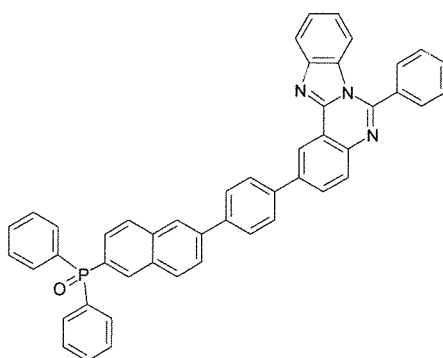

[Formula 1-9]

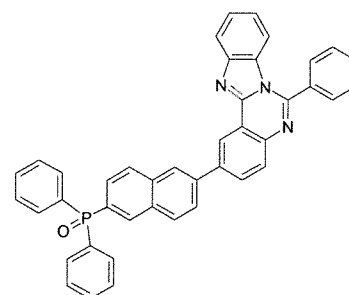

[Formula 1-10]

5

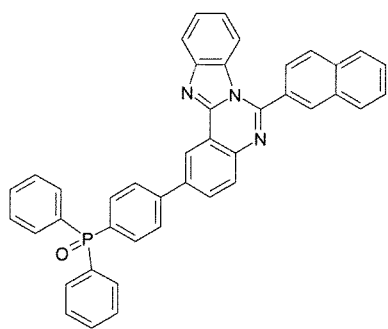

[Formula 1-11]

10

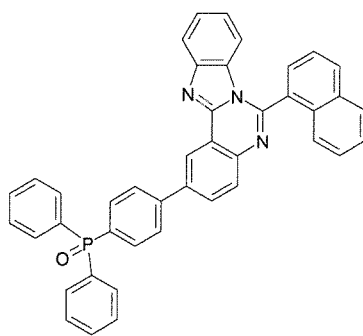

[Formula 1-12]

15

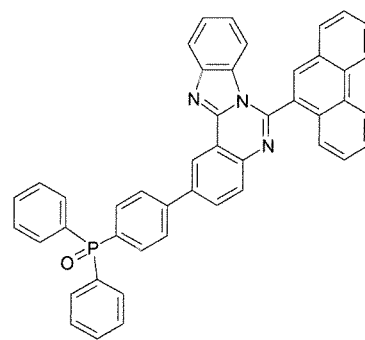

[Formula 1-13]

20

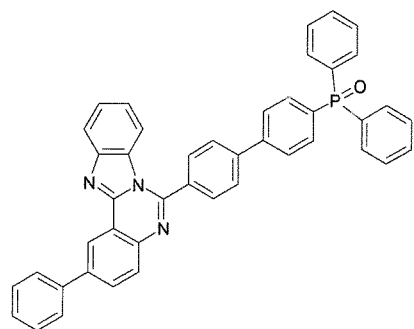

[Formula 1-14]

25

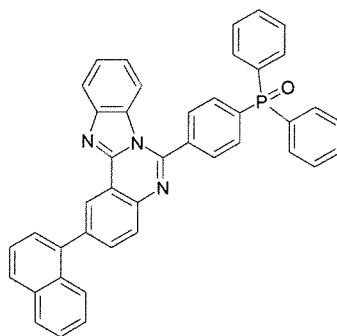

[Formula 1-15]

30

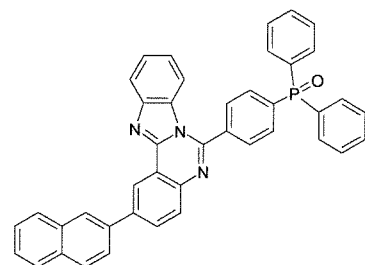

[Formula 1-16]

35

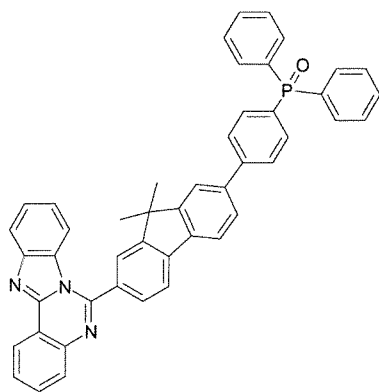

[Formula 1-17]

40

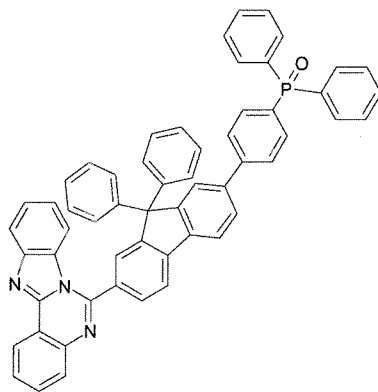

[Formula 1-18]

45

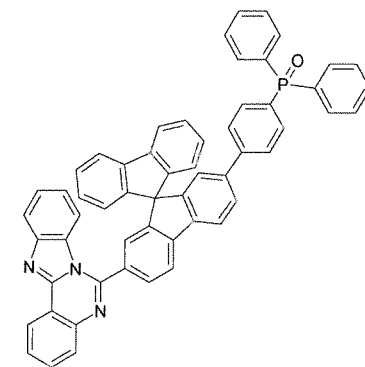

50

55

[Formula 1-19]

5

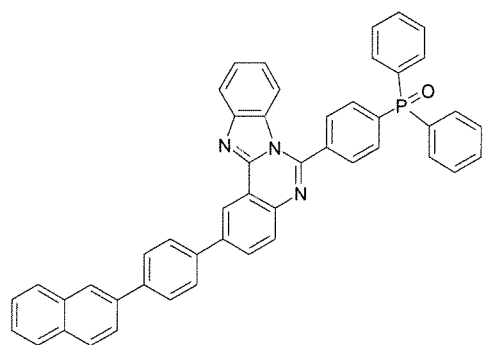

10

15

[Formula 1-20]

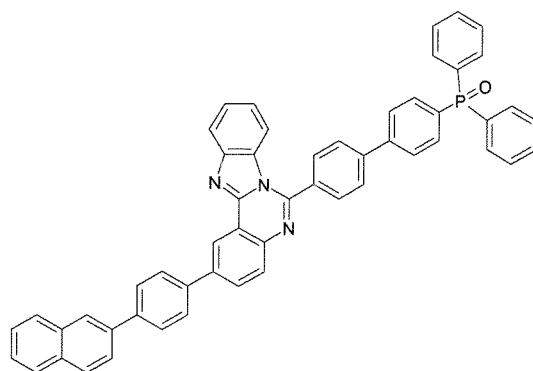

[Formula 1-21]

[Formula 1-22]

[Formula 1-23]

20

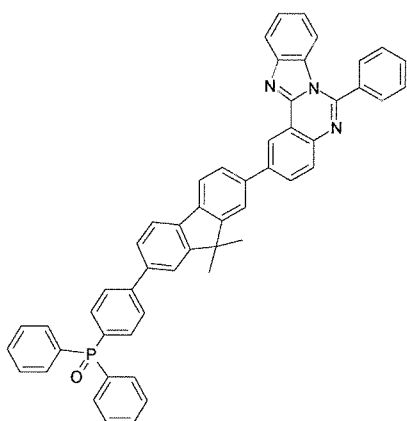

25

30

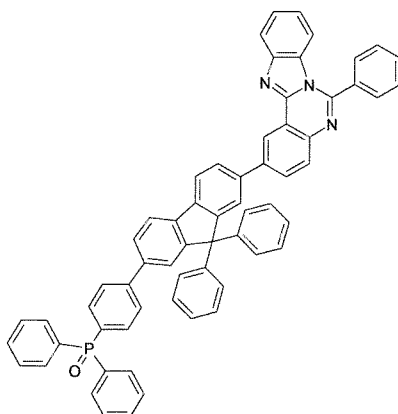

35

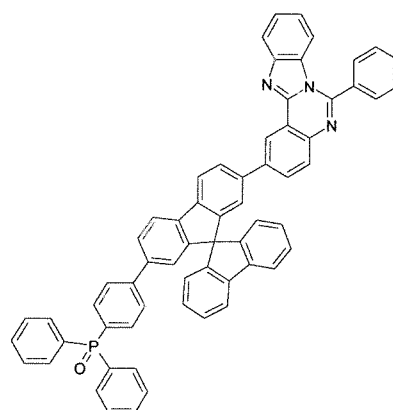

[Formula 1-24]

[Formula 1-25]

40

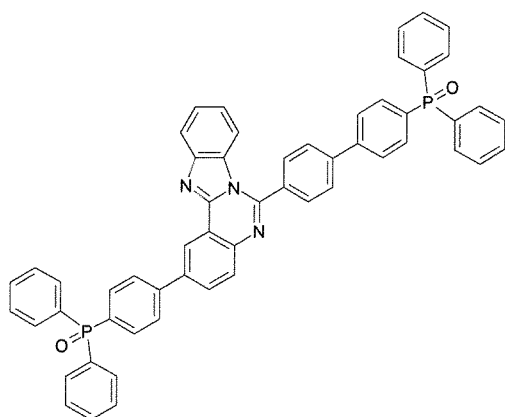

45

50

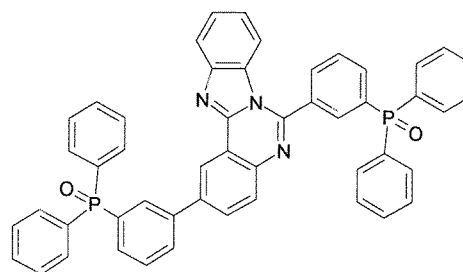

55

[Formula 1-26]

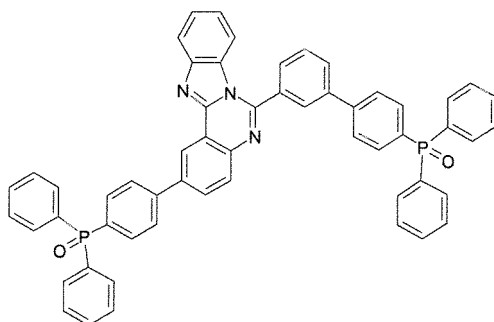

[0037] Hereinafter, a method for preparing the compound represented by Formula 1 will be described.

[0038] The compound represented by Formula 1 may be prepared by using general methods known in the art, such as condensation reaction, Suzuki coupling reaction and the like.

[0039] The compounds represented by Formula 1 may have properties appropriate for use as an organic material layer used in an organic light emitting device by introducing various substituents into a core structure represented in the Formula. The compound represented by Formula 1 may show properties even when used in any layer of the organic light emitting device, but particularly, the following characteristics may be exhibited.

[0040] The compounds into which a substituted or unsubstituted arylamine group is introduced are appropriate as a material for a light emitting layer and a hole injection and hole transporting layer, and the compounds into which a heterocyclic group comprising N is introduced are appropriate as a material for an electron injection layer, an electron transferring layer and a hole blocking layer.

[0041] The conjugation length of the compound has a close relationship with an energy band gap. Specifically, the energy band gap is reduced as the conjugation length of the compound increases. As described above, the cores of the compounds represented by Formula 1 comprises a limited conjugation and thus have properties from a small energy band gap to a large energy band gap.

[0042] In addition, a compound having intrinsic properties of a substituent group introduced may be synthesized by introducing various substituent groups into the core structure as described above. For example, hole injection layer materials and hole transporting layer materials which are used during the manufacture of an organic light emitting device have an energy level enough to transfer holes along the HOMO, and may become a compound capable of having an energy level enough to prevent the movement of electrons flowing along the LUMO from the light emitting layer. In particular, the core structure of the present compound shows stable properties for electrons, thereby contributing to the improvement in the service life of the device. Derivatives produced by introducing substituents so as to be used in the light emitting layer and electron transport layer material may be prepared such that various arylamine-based dopants, aryl-based dopants, dopants containing metals and the like have a suitable energy band gap.

[0043] Furthermore, it is possible to precisely control the energy band gap by introducing various substituent groups into the core structure, and properties at the interface between organic materials are improved, thereby making it possible to use the material in various fields.

[0044] Meanwhile, the compounds represented by Formula 1 have a high glass transition temperature (T_g), and thus have excellent thermal stability. The improvement in thermal stability is an important factor which provides the driving stability to a device.

[0045] Further, the organic electronic device according to the present invention is an organic electronic device comprising a first electrode, a second electrode, and one or more organic material layers disposed between the first electrode and the second electrode, and one or more layers of the organic material layers comprise the compound represented by Formula 1.

[0046] The organic electronic device of the present invention may be manufactured by typical manufacturing methods of an organic electronic device and materials, except that one or more organic material layers are formed by using the above-described compounds.

[0047] The compound of Formula 1 may be formed as an organic material layer by using a vacuum deposition method as well as a solution coating method during the manufacture of an organic electronic device. Herein, the solution coating method means spin coating, dip coating, inkjet printing, screen printing, a spray method, roll coating and the like, but is not limited thereto.

[0048] The organic material layer of the organic electronic device of the present invention may be composed of a mono-layer structure, but may be composed of a multi-layer structure in which two or more organic material layers are stacked. For example, the organic electronic device of the present invention may have a structure comprising a hole injection layer, a hole transporting layer, a light emitting layer, an electron transporting layer, an electron injection layer and the like as an organic material layer. However, the structure of the organic electronic device is not limited thereto,

and may comprise the fewer number of organic material layers.

[0049] Accordingly, in the organic electronic device of the present invention, the organic material layer may comprise one or more layers of a hole injection layer, a hole transporting layer, and a layer which injects and transports holes simultaneously, and one or more layers of the layers may comprise the compound represented by Formula 1.

[0050] In addition, the organic material layer may comprise a light emitting layer, and the light emitting layer may comprise the compound represented by Formula 1.

[0051] Furthermore, the organic material layer may comprise one or more layers of an electron transporting layer, an electron injection layer, and a layer which transports and injects electrons simultaneously, and one or more layers of the layers may comprise the compound represented by Formula 1.

[0052] In the organic material layer having the multi-layer structure, the compound of Formula 1 may be comprised in a light emitting layer, a layer which injects/transportes holes and emits light simultaneously, a layer which transports holes and emits light simultaneously, or a layer which transports electrons and emits light simultaneously.

[0053] For example, the structure of the organic light emitting device of the present invention has the same structure as the structures shown in FIGS. 1 to 4, but is not limited thereto.

[0054] FIG. 1 illustrates a structure of an organic light emitting device in which an anode 102, a light emitting layer 105 and a cathode 107 are sequentially stacked on a substrate 101. In the structure, the compound of Formula 1 may be comprised in the light emitting layer 105.

[0055] FIG. 2 illustrates a structure of an organic light emitting device in which an anode 102, a hole injection/hole transporting and light emitting layer 105, an electron transporting layer 106 and a cathode 107 are sequentially stacked on a substrate 101. In the structure, the compound of Formula 1 may be comprised in the hole injection/hole transporting and light emitting layer 105.

[0056] FIG. 3 illustrates a structure of an organic light emitting device in which a substrate 101, an anode 102, a hole injection layer 103, a hole transporting and light emitting layer 105, an electron transporting layer 106 and a cathode 107 are sequentially stacked. In the structure, the compound of Formula 1 may be comprised in the hole injection/hole transporting and light emitting layer 105.

[0057] FIG. 4 illustrates a structure of an organic light emitting device in which a substrate 101, an anode 102, a hole injection layer 103, a hole transporting layer 104, an electron transporting and light emitting layer 105 and a cathode 107 are sequentially stacked. In the structure, the compound of Formula 1 may be comprised in the electron transporting and light emitting layer 105.

[0058] In the organic electronic device of the present invention, the compound represented by Formula 1 is more preferably comprised in the electron transporting layer, a layer that transports and injects electrons simultaneously or a light emitting layer.

[0059] For example, the organic light emitting device according to the present invention may be manufactured by depositing a metal or a metal oxide having conductivity, or an alloy thereof on a substrate to form an anode by a physical vapor deposition (PVD) method such as sputtering or e-beam evaporation, forming an organic material layer which comprises a hole injection layer, a hole transporting layer, a light emitting layer, and an electron transporting layer thereon, and then depositing a material which may be used as the cathode thereon. In addition to these methods, an organic light emitting device may be manufactured by sequentially depositing a cathode material, an organic material layer and an anode material on a substrate.

[0060] The organic material layer may be a multi-layer structure comprising the hole injection layer, the hole transporting layer, the light emitting layer, the electron transporting layer and the like, but may be a mono-layer structure without being limited thereto. Further, the organic material layer may be manufactured with fewer layers by using various polymer materials by a solvent process other than a deposition method, for example, methods such as spin coating, dip coating, doctor blading, screen printing, inkjet printing, a thermal transfer method or the like.

[0061] It is preferred that as the anode material, materials having a high work function are typically used so as to facilitate the injection of holes into the organic material layer. Specific examples of the anode material which may be used in the present invention comprise metals such as vanadium, chromium, copper, zinc, and gold or alloys thereof; metal oxides such as zinc oxide, indium oxide, indium tin oxide (ITO), and indium zinc oxide (IZO); a combination of metal and oxide such as ZnO:Al or SnO₂:Sb; and electrically conductive polymers such as poly(3-methylcompound), poly[3,4-(ethylene-1,2-dioxy)compound](PEDT), polypyrrole, and polyaniline, and the like, but are not limited thereto.

[0062] It is preferred that as the cathode material, materials having a low work function are typically used so as to facilitate the injection of electrons into the organic material layer. Specific examples of the cathode material include metals such as magnesium, calcium, sodium, potassium, titanium, indium, yttrium, lithium, gadolinium, aluminum, silver, tin and lead or alloys thereof; multilayer structured materials such as LiF/Al or LiO₂/Al, and the like, but are not limited thereto.

[0063] The hole injection material is a material facilitating the injection of holes from the anode at low voltage. The highest occupied molecular orbital (HOMO) of the hole injection material is preferably between the work function of the anode materials and the HOMO of the neighboring organic material layer. Specific examples of the hole injection material

include metal porphyrine, oligothiophene, arylamine-based organic materials, hexanitrile hexaazatriphenylene-based organic materials, quinacridone-based organic materials, perylene-based organic materials, anthraquinone, and poly-aniline-based and polycarbonate-based conductive polymers, and the like, but are not limited thereto.

[0064] The hole transporting material is suitably a material having high hole mobility, which may receive and transfer holes from the anode or the hole injection layer to the light emitting layer. Specific examples thereof include arylamine-based organic materials, conductive polymers, block copolymers having both conjugated portions and non-conjugated portions, and the like, but are not limited thereto.

[0065] The light emitting material is a material capable of emitting light in a visible light region by accepting and recombining holes from the hole transporting layer and electrons from the electron transporting layer, respectively, and preferably a material having high quantum efficiency for fluorescence and phosphorescence. Specific examples thereof include 8-hydroxy-quinoline-aluminum complex (Alq₃); carbazole-based compounds; dimerized styryl compounds; BAlq; 10-hydroxybenzoquinoline-metal compounds; benzoxazole-based, benzthiazole-based and benzimidazole-based compounds; poly(p-phenylenevinylene)(PPV)-based polymers; spiro compounds; and polyfluorene, rubrene and the like, but are not limited thereto.

[0066] The electron transporting material is suitably a material having high electron mobility, which may receive and transfer electrons from the cathode to the light emitting layer. Specific examples thereof include aluminum complexes of 8-hydroxyquinoline; complexes comprising Alq₃; organic radical compounds; hydroxyflavone-metal complexes, and the like, but are not limited thereto.

[0067] The organic light emitting device according to the present invention may be a top emission type, a bottom emission type or a both side emission type according to the materials used.

[0068] The compound according to the present invention may be operated by the principles similar to the principles, which are applied to organic light emitting devices, even in organic electronic devices comprising organic solar cells, organic photoconductors, organic transistors, and the like.

[0069] Accordingly, the organic electronic device may be selected from the group consisting of an organic light emitting device, an organic phosphorescence device, an organic solar cell, an organic photoconductor (OPC) and an organic transistor.

[Best Mode]

[0070] Hereinafter, preferred Examples will be provided for better understanding of the present invention. However, the following Examples are for illustrative purposes only, and the scope of the present invention are not limited thereto in any manner.

<Example>

<Preparation Example 1> Preparation of Compound Represented by Formula 1-2

[0071]

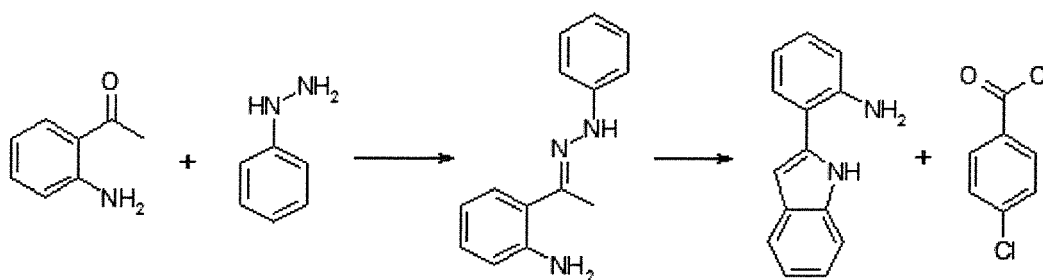

Structural Formula 1-2A Structural Formula 1-2B

5

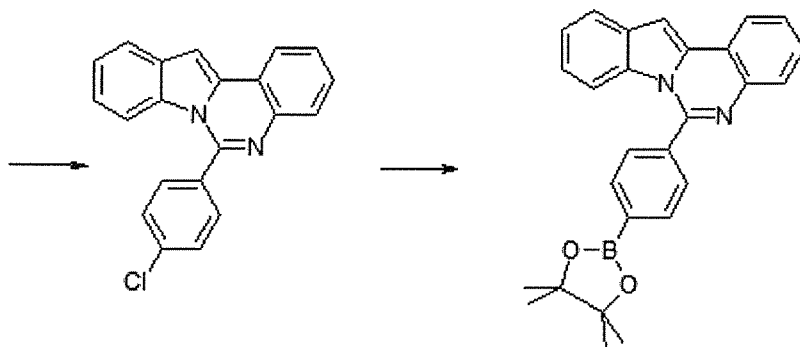

Structural Formula 1-2C

Structural Formula 1-2D

10

15

20

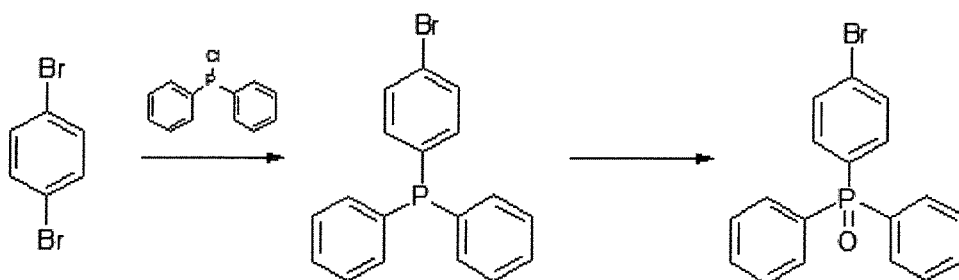

Structural Formula 1-2E

Structural Formula 1-2F

25

30

35

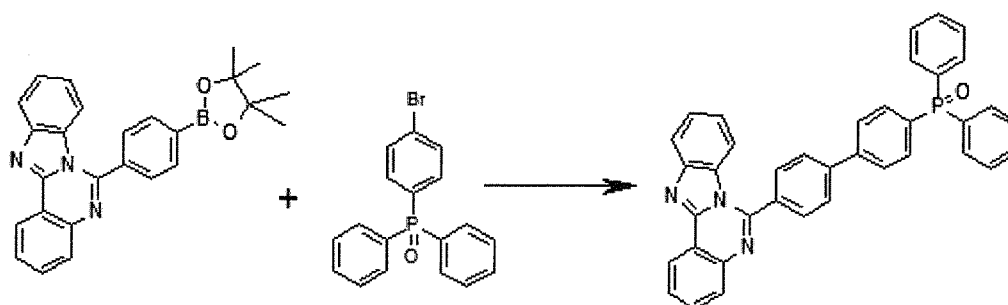

Structural Formula 1-2

40

Preparation of Structural Formula 1-2A

[0072] 2'-aminoacetophenone (9.6 mL, 80 mmol) and phenylhydrazine (15 g, 103.7 mmol) were put into ethanol (100 mL) and glacial acetic acid (30 mL) and the mixture was heated while stirring for 5 hr. The mixture was cooled to normal temperature, and the solid produced was filtered and washed with ethanol (30 mL) and then dried under vacuum to obtain Structural Formula 1-2A (14 g, yield 83%).

MS: [M+H]⁺ = 226

Preparation of Structural Formula 1-2B

50

[0073] Phosphorus pentoxide (8.4 g, 58.7 mmol) was put into methane sulfonic acid (100 mL) and the mixture was stirred at 80°C until the phosphorus pentoxide was completely dissolved. Structural Formula 1-2A (6.3 g, 28 mmol) was slowly added thereto, and then the mixture was stirred at 90°C for 3 hr and cooled to normal temperature. The reaction solution was put into a sodium hydroxide aqueous solution at 0°C, the mixture was stirred for 10 min, and then the solid produced was filtered. The solid was washed with distilled water and dried under vacuum to obtain Structural Formula 1-2B (4 g, yield 69%).

MS: [M+H]⁺ = 209

55

EP 2 719 741 B1

Preparation of Structural Formula 1-2C

5 [0074] Structural Formula 1-2B (4 g, 19.2 mmol) and 4-chlorobenzoyl chloride (2.4 mL, 19.2 mmol) were put into p-toluene sulfonic acid (50 mL) and the mixture was heated while stirring for 5 hr. The mixture was cooled to 50°C, and then 2,3-dichloro-5,6-dicyano-1,4-benzoquinone (DDQ) (4.8 g, 21.1 mmol) was slowly added thereto. The mixture was heated while stirring for 2 hr and then cooled to normal temperature, and a potassium carbonate aqueous solution was slowly added thereto. The mixture was stirred for 30 min, the water layer was removed, and the solid produced was filtered. The filtered solid was recrystallized in chloroform to obtain Structural Formula 1-2C (5 g, 79%).

10 MS: [M+H]⁺ = 328

Preparation of Structural Formula 1-2D

15 [0075] Structural Formula 1-2C (13 g, 40 mmol), bis(pinacolato)diboron (12 g, 47 mmol) and potassium acetate (12 g, 118 mmol) were dissolved in dioxane (150 mL), the mixture was heated to 50°C, Pd(DBA)₂ (0.23 g, 0.4 mmol) and P(Cy)₃ (0.22 g, 0.8 mmol) were added thereto, and the resulting mixture was heated while stirring for 12 hr. The reaction solution was cooled to room temperature, distilled water (100 mL) was added thereto, and the mixture was extracted with methylene chloride (100 mL x 3). The organic layer was concentrated and recrystallized with ethanol to obtain Structural Formula 1-2D (14 g, yield 90%).

20 MS: [M+H]⁺ = 420

Preparation of Structural Formula 1-2E

25 [0076] Dibromobenzene (20 g, 85 mmol) was dissolved in tetrahydrofuran (100 ml), and then the mixture was cooled to 78°C. n-BuLi (2.5 M, 37 ml, 93 mmol) was slowly added dropwise thereto, and then the resulting mixture was stirred for 30 min. Chlorodiphenylphosphine (17 g, 76 mmol) was slowly added dropwise thereto, the mixture was stirred for 3 hr and heated to normal temperature, and then water (100 ml) was added thereto and the resulting mixture was extracted with tetrahydrofuran. The organic layer was concentrated and recrystallized with hexane to obtain Structural Formula 1-2E (20g, yield 70%).

30 MS: [M+H]⁺ = 342

Preparation of Structural Formula 1-2F

35 [0077] The Structural Formula 1-2E (20 g, 58 mmol) was dissolved in trichloromethane (200 ml), a hydrogen peroxide solution (20 ml) was added thereto, and then the resulting mixture was stirred for 12 hr. MgSO₄ was added thereto and the mixture was stirred to remove water, the resulting mixture was filtered, concentrated and recrystallized with hexane to obtain Structural Formula 1-2F (18 g, yield 85%).

MS: [M+H]⁺ = 358

Preparation of Formula 1-2

40 [0078] Structural Formula 1-2D (9.4g, 22.4 mmol) and Structural Formula 1-2F (8 g, 22.4 mmol) were heated until they were completely dissolved in tetrahydrofuran (200 ml), then 100 ml of a 2 M potassium carbonate aqueous solution was added to the solution, Pd(PPh₃)₄ (0.26 g, 0.22 mmol) was added thereto, and the mixture was stirred for 12 hr. The mixture was cooled to normal temperature, the water layer was removed, and the solid produced was filtered. The solid filtered was recrystallized with tetrahydrofuran and acetone to obtain Formula 1-2 (8g, yield 62%).

45 MS: [M+H]⁺ = 572

<Preparation Example 2> Preparation of Compound Represented by Formula 1-4

50 [0079]

55

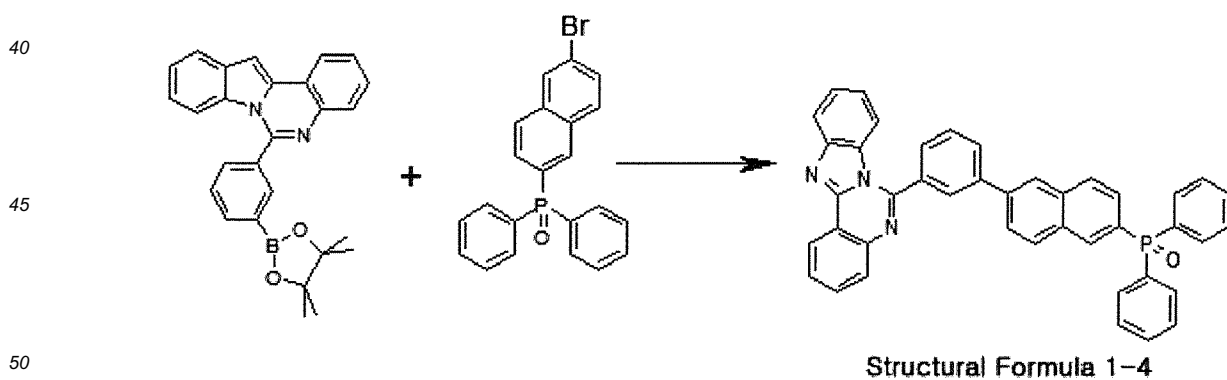
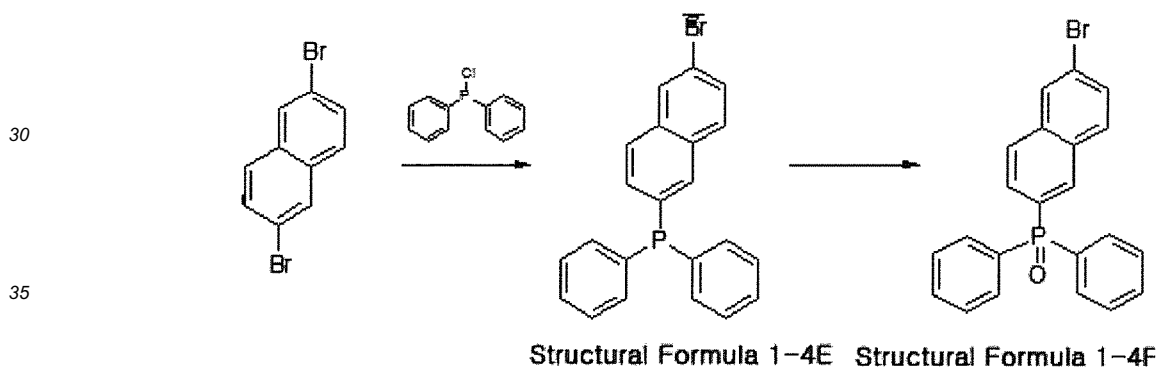
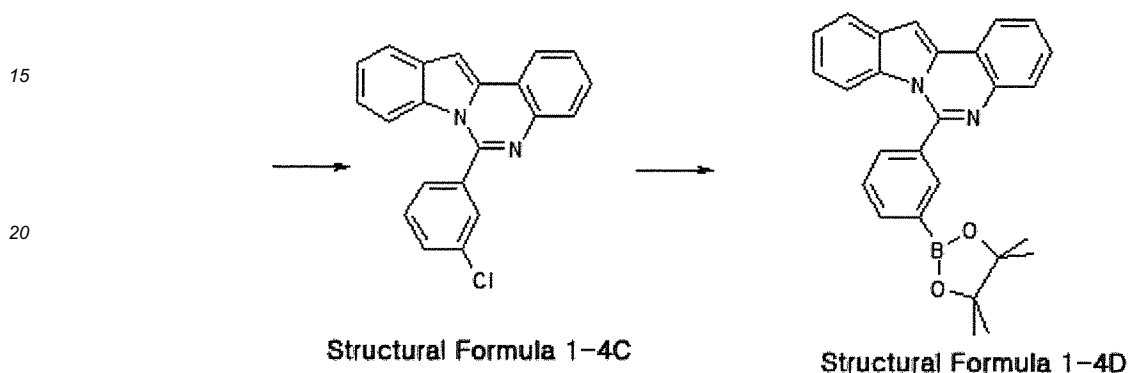
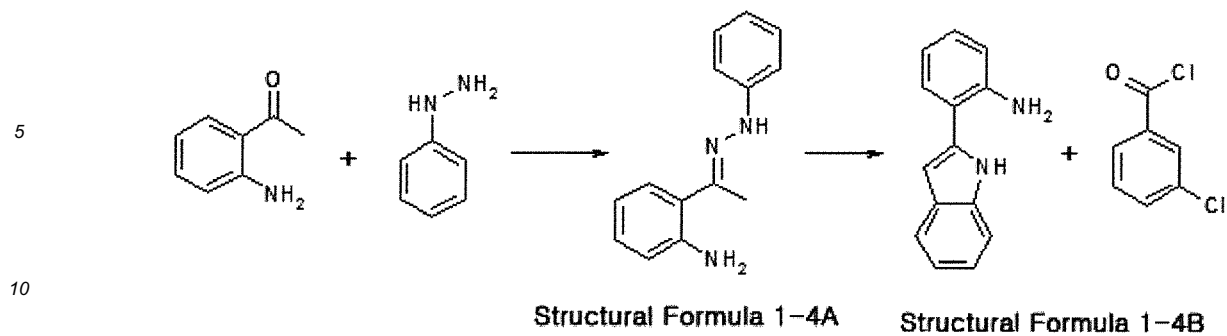

Preparation of Structural Formula 1-4C

55 [0080] Structural Formula 1-4C was obtained in the same manner as in the preparation method of Structural Formula 1-2C, except that 3-chlorobenzoyl chloride was used instead of 4-chlorobenzoyl chloride.
MS: [M+H]⁺ = 328

Preparation of Structural Formula 1-4D

[0081] Structural Formula 1-4D was obtained in the same manner as in the preparation method of Structural Formula 1-2D, except that Structural Formula 1-4C was used instead of Structural Formula 1-2C.

MS: [M+H]⁺ = 420

Preparation of Structural Formula 1-4E

[0082] Structural Formula 1-4E was obtained in the same manner as in the preparation method of Structural Formula 1-2E, except that 2,6-dibromonaphthalene was used instead of 1,4-dibromobenzene.

MS: [M+H]⁺ = 392

Preparation of Structural Formula 1-4F

[0083] Structural Formula 1-4F was obtained in the same manner as in the preparation method of Structural Formula 1-2F, except that Structural Formula 1-4E was used instead of Structural Formula 1-2E.

MS: [M+H]⁺ = 408

Preparation of Formula 1-4

[0084] Formula 1-4 was obtained in the same manner as in the preparation method of Formula 1-2, except that Structural Formula 1-4D and Structural Formula 1-4F were used instead of Structural Formula 1-2D and Structural Formula 1-2F, respectively.

MS: [M+H]⁺ = 622

<Preparation Example 3> Preparation of Compound Represented by Formula 1-7

[0085]

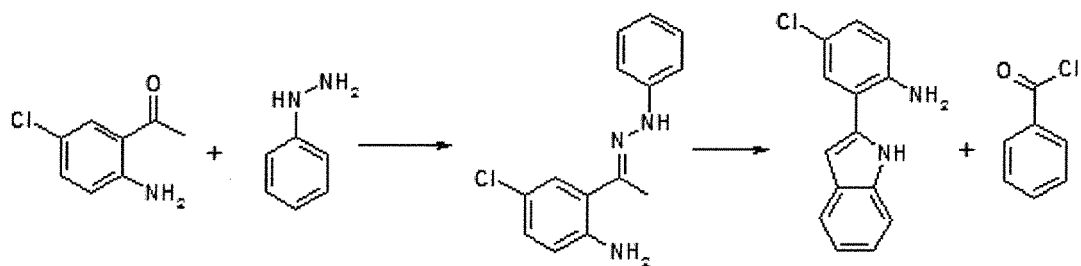

Structural Formula 1-7A Structural Formula 1-7B

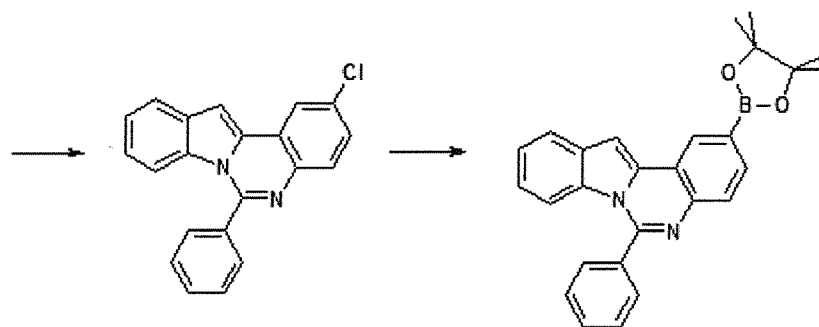

Structural Formula 1-7C

Structural Formula 1-7D

5

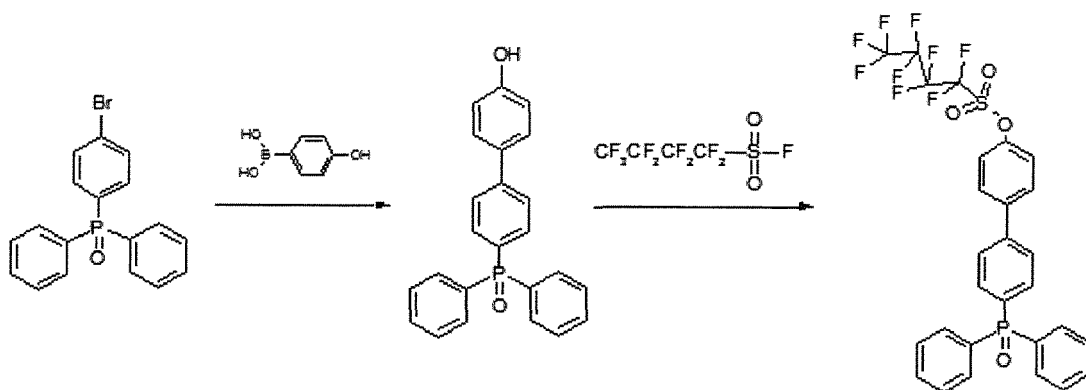

Structural Formula 1-7E

Structural Formula 1-7F

15

20

25

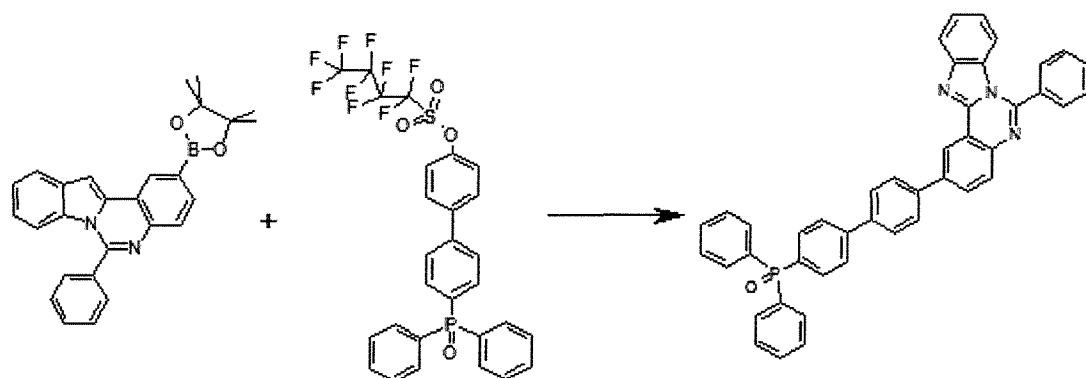

Structural Formula 1-7

30

Preparation of Structural Formula 1-7A

[0086] Structural Formula 1-7A was obtained in the same manner as in the preparation method of Structural Formula 1-2A, except that 2'-amino-5-chloroacetophenone was used instead of 2'-aminoacetophenone.

MS: $[M+H]^+ = 260$

35

Preparation of Structural Formula 1-7B

[0087] Structural Formula 1-7B was obtained in the same manner as in the preparation method of Structural Formula 1-2B, except that Structural Formula 1-7A was used instead of Structural Formula 1-2A.

40

MS: $[M+H]^+ = 243$

Preparation of Structural Formula 1-7C

[0088] Structural Formula 1-7C was obtained in the same manner as in the preparation method of Structural Formula 1-2C, except that benzoyl chloride was used instead of 4-chlorobenzoyl chloride.

45

MS: $[M+H]^+ = 329$

Preparation of Structural Formula 1-7D

50

[0089] Structural Formula 1-7D was obtained in the same manner as in the preparation method of Structural Formula 1-2D, except that Structural Formula 1-7C was used instead of Structural Formula 1-2C.

MS: $[M+H]^+ = 421$

Preparation of Structural Formula 1-7E

55

[0090] Structural Formula 1-2F (8 g, 22.4 mmol) and 4-hydroxyphenylboronic acid (3.1 g, 22.4 mmol) were heated until they were completely dissolved in tetrahydrofuran (200 ml), then 100 ml of a 2 M potassium carbonate aqueous solution was added to the solution, Pd(PPh₃)₄ (0.26 g, 0.22 mmol) was added thereto, and the mixture was stirred for

12 hr. The mixture was cooled to normal temperature, an organic layer was extracted, and then a solid produced by distilling off the solvent was filtered. The solid filtered was recrystallized with tetrahydrofuran and hexane to obtain Structural Formula 1-7E (7 g, yield 84%).

MS: $[M+H]^+ = 371$

5

Preparation of Structural Formula 1-7F

[0091] Structural Formula 1-7E (7 g, 18.9 mmol) was dissolved in acetonitrile (200 ml), perchlorobutane sulfonylchloride (2.9 g, 20.8 mmol) and 100 ml of a 2 M potassium carbonate aqueous solution were added thereto and heated, and then the mixture was stirred for 12 hr. The mixture was cooled to normal temperature, an organic layer was extracted, and then a solid produced by distilling off the solvent was filtered. The solid filtered was recrystallized with chloroform and hexane to obtain Structural Formula 1-7F (9.5 g, yield 75%).

MS: $[M+H]^+ = 653$

15

Preparation of Formula 1-7

[0092] Formula 1-7 was obtained in the same manner as in the preparation method of Formula 1-2, except that Structural Formula 1-7D and Structural Formula 1-7F were used instead of Structural Formula 1-2D and Structural Formula 1-2F, respectively.

MS: $[M+H]^+ = 648$

20

<Preparation Example 4> Preparation of Compound Represented by Formula 1-24

[0093]

25

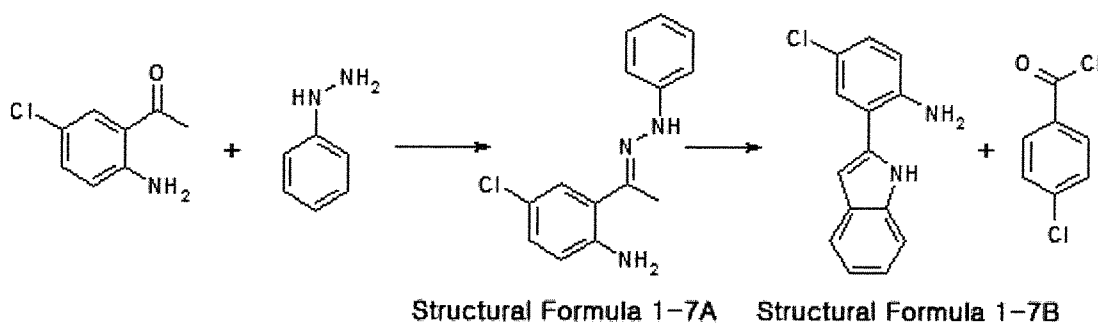

30

35

40

45

50

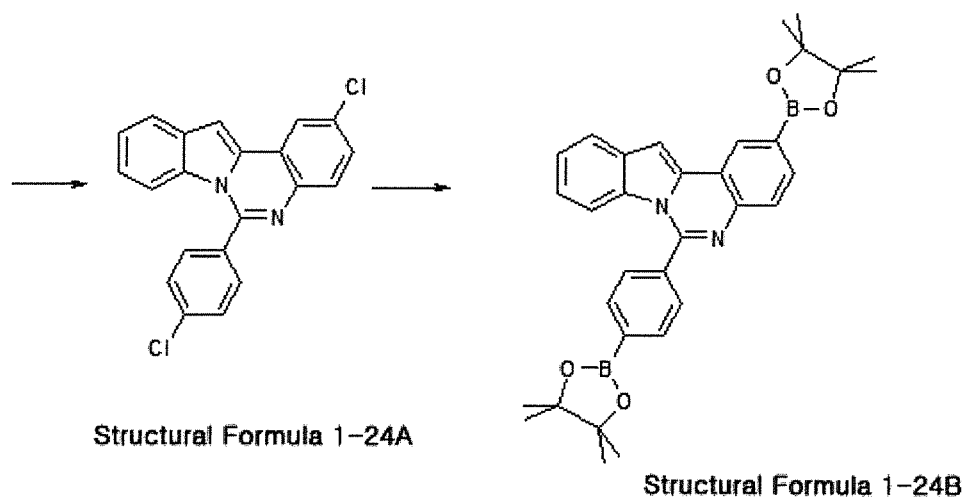

55

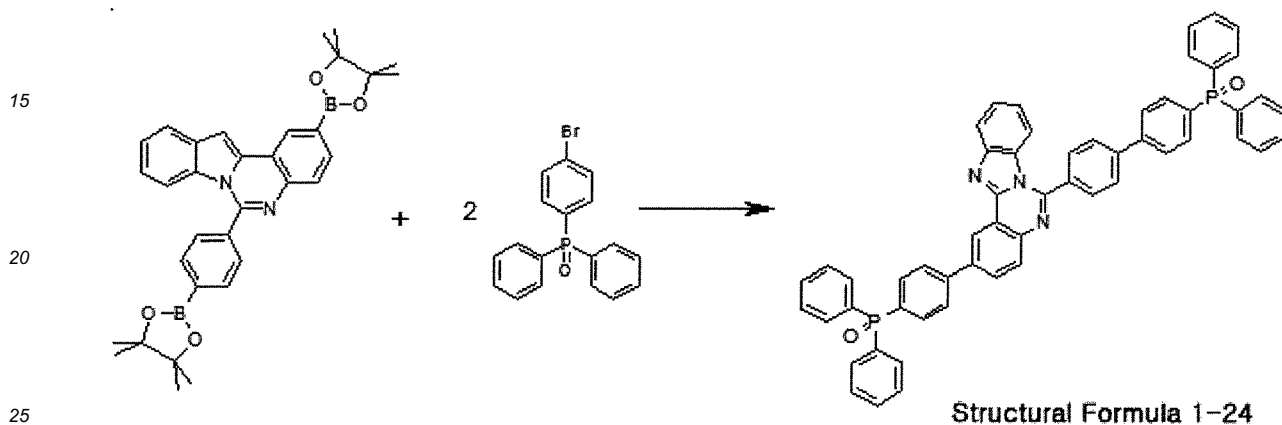
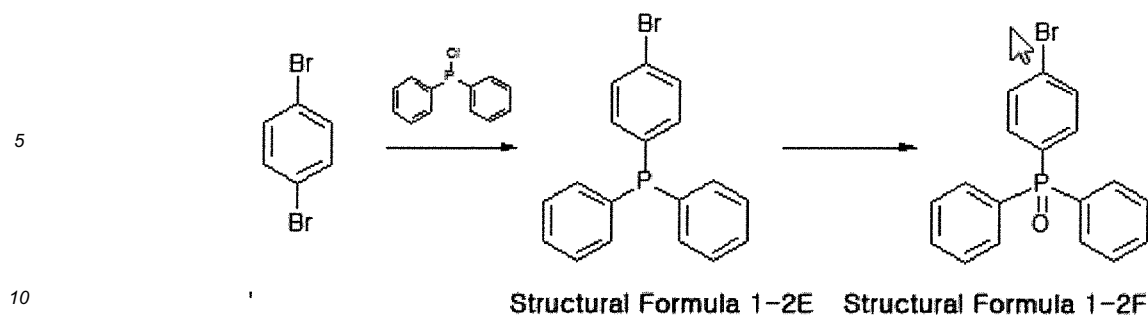

Preparation of Structural Formula 1-24A

30 **[0094]** Structural Formula 1-24A was obtained in the same manner as in the preparation method of Structural Formula 1-7C, except that 4-chlorobenzoyl chloride was used instead of benzoyl chloride.
MS: $[M+H]^+ = 363$

Preparation of Structural Formula 1-24B

35 **[0095]** Structural Formula 1-24B was obtained in the same manner as in the preparation method of Structural Formula 1-7D, except that Structural Formula 1-24A was used instead of Structural Formula 1-7C.
MS: $[M+H]^+ = 547$

Preparation of Formula 1-24

40 **[0096]** Formula 1-24 was obtained in the same manner as in the preparation method of Formula 1-2, except that Structural Formula 1-24B was used instead of Structural Formula 1-2D.
MS: $[M+H]^+ = 848$

<Example 1>

45 **[0097]** A glass substrate (coming 7059 glass), on which ITO (indium tin oxide) was coated to a thickness of 1,000 Å to form a thin film, was put in a distilled water in which a dispersing agent was dissolved, and then washed using ultrasonic waves. A product manufactured by Fischer Co. was used as a detergent, and distilled water twice filtered by a filter manufactured by Millipore Co. was used as the distilled water. After ITO was washed for 30 min, ultrasonic washing was twice conducted by using distilled water for 10 min. After the washing using distilled water was completed, ultrasonic washing was conducted using isopropyl alcohol, acetone, and methanol solvents in sequence, and drying was then conducted.

50 **[0098]** Hexanitrile hexaazatriphenylene was vacuum deposited to a thickness of 500 Å by heating on a transparent ITO electrode, which was thus prepared, so as to form a hole injection layer. NPB (400 Å), which is a material that transports holes, was vacuum deposited thereon, and a compound of host H1 and dopant D1 was vacuum deposited to a thickness of 300 Å as a light emitting layer. Then, the compound of Formula 1-2, which was synthesized in Preparation Example 1, and LIQ were vacuum deposited (to a thickness of 200 Å) by heating as an electron injection and transporting

layer. An organic light emitting device was manufactured by sequentially depositing lithium quinolate (LiQ) having a thickness of 12 Å and aluminum having a thickness of 2,000 Å on the electron transporting layer to form a cathode.

[0099] E1 was used as a Comparative Example of the electron transporting layer.

[0100] In the above-described procedure, the deposition rate of organic materials was maintained at 1 Å/sec, while the deposition rates of lithium quinolate and aluminum were maintained at 0.2 Å/sec and 3 Å/sec to 7 Å/sec, respectively.

[Hexanitrite hexaazatriphenylene] [NPB]

[0101]

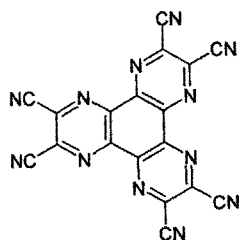

[H1]

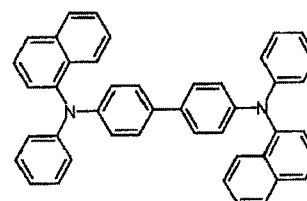

[H2]

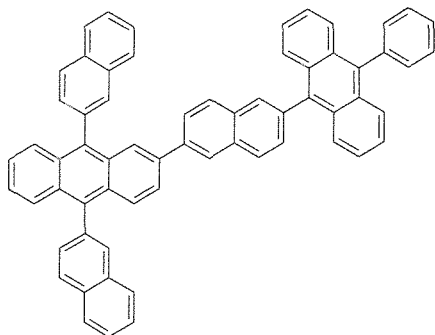

[D1]

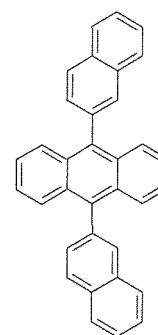

[D2]

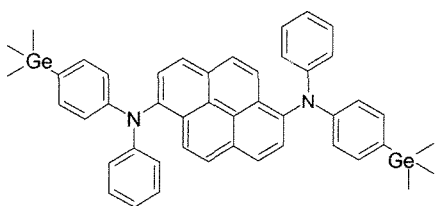

[E1]

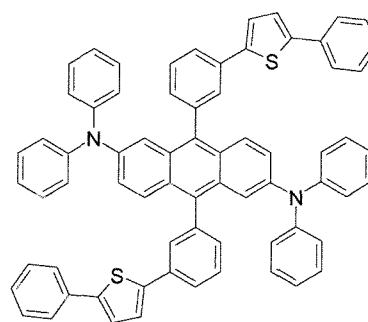

[Alq3]

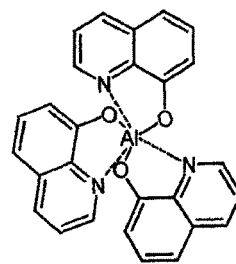
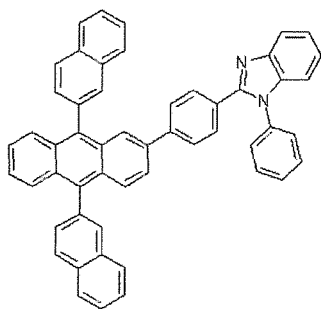
**<Example 2>**

[0102] An experiment was performed in the same manner as in Example 1, except that Formula 1-4 was used as the electron transporting layer instead of Formula 1-2.

<Example 3>

[0103] An experiment was performed in the same manner as in Example 1, except that Formula 1-7 was used as the electron transporting layer instead of Formula 1-2.

<Example 4>

[0104] An experiment was performed in the same manner as in Example 1, except that Formula 1-24 was used as the electron transporting layer instead of Formula 1-2.

<Comparative Example 1>

[0105] An experiment was performed in the same manner as in Example 1, except that E1 was used as the electron transporting layer instead of Formula 1-2.

[0106] As in the Example, the results obtained by performing an experiment on an organic light emitting device manufactured by using each compound as a hole transporting layer material are shown in Table 1.

[Table 1]

Experimental Example (5 mA/cm ²)	ETL material	Voltage (V)	Efficiency (cd/A)	Color coordinate (x, y)	Service life (Td5) (hr)
Comparative Example 1	E1	4.11	19.05	(0.314, 0.650)	94
Example 1	Formula 1-2	6.28	17.09	(0.315, 0.650)	590
Example 2	Formula 1-4	5.01	19.24	(0.314, 0.655)	256
Example 3	Formula 1-7	4.90	17.88	(0.311, 0.654)	183
Example 4	Formula 1-24	5.07	15.63	(0.315, 0.655)	309

[0107] As shown in the results, the new compound according to the present invention may be used as a material for an organic material layer of an organic electronic device comprising an organic light emitting device by introducing various substituent groups and the like. The organic electronic device comprising an organic light emitting device using the compound represented by Formula 1 according to the present invention as a material for an organic material layer shows excellent properties in terms of efficiency, driving voltage, service life and the like.

Claims

1. A compound represented by the following Formula 1:

[Formula 1]

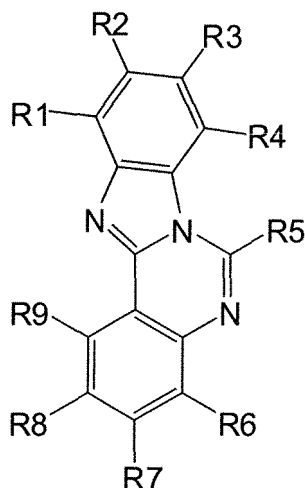

wherein

at least one of R1 to R9 is represented by the following Formula 2 and the rest thereof are hydrogen; deuterium; a halogen group; a nitrile group; a nitro group; a hydroxyl group; a substituted or unsubstituted cycloalkyl group; a substituted or unsubstituted alkoxy group; a substituted or unsubstituted aryloxy group; a substituted or unsubstituted alkylthioxy group; a substituted or unsubstituted arylthioxy group; a substituted or unsubstituted alkylsulfoxy group; a substituted or unsubstituted arylsulfoxy group; a substituted or unsubstituted alkenyl group; a substituted or unsubstituted silyl group; a substituted or unsubstituted boron group; a substituted or unsubstituted alkylamine group; a substituted or unsubstituted aralkylamine group; a substituted or unsubstituted arylamine group; a substituted or unsubstituted heteroarylamine group; a substituted or unsubstituted aryl group; a substituted or unsubstituted fluorenyl group; a substituted or unsubstituted carbazole group; or a substituted or unsubstituted heterocyclic group comprising one or more of N, O, and S atoms;

[Formula 2]

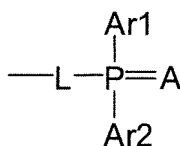

L is a direct bond; a substituted or unsubstituted arylene group; or a substituted or unsubstituted heteroarylene group comprising one or more of N, O and S atoms,

Ar1 and Ar2 are each independently a substituted or unsubstituted aryl group; or a substituted or unsubstituted heterocyclic group comprising one or more of N, O and S atoms; and
A is O, S or Se.

2. The compound of claim 1, wherein R5 in Formula 1 is represented by Formula 2.
3. The compound of claim 1, wherein the compound represented by Formula 1 is represented by any one of the following Formulas:

[Formula 1-1]

5

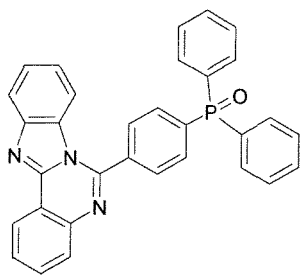

10

[Formula 1-2]

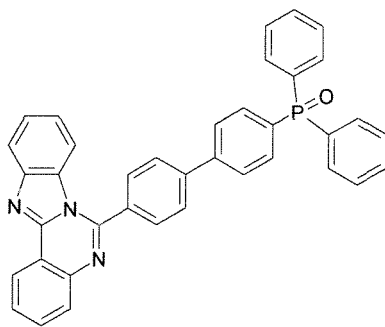

[Formula 1-3]

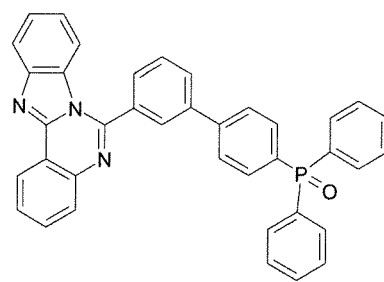

15

[Formula 1-4]

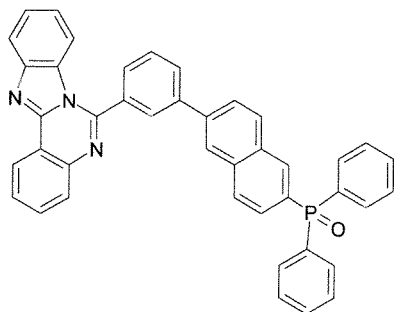

20

[Formula 1-5]

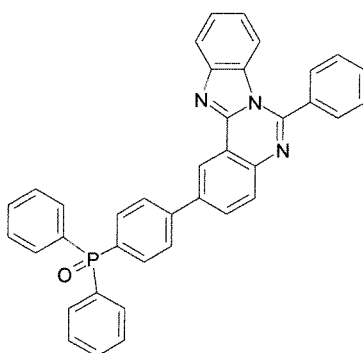

25

[Formula 1-6]

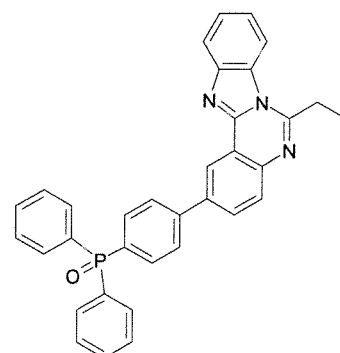

30

[Formula 1-7]

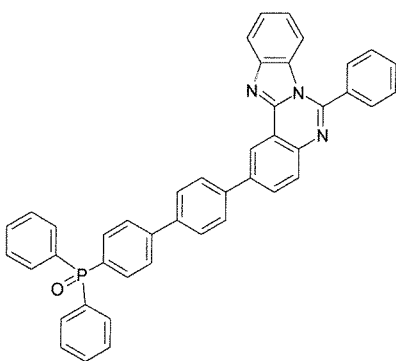

35

[Formula 1-8]

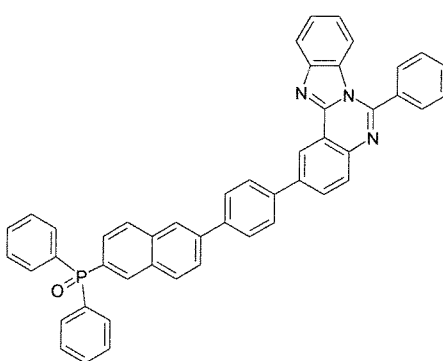

40

[Formula 1-9]

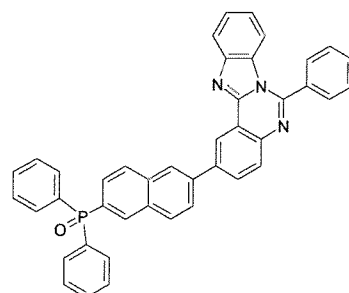

45

50

55

[Formula 1-10]

5

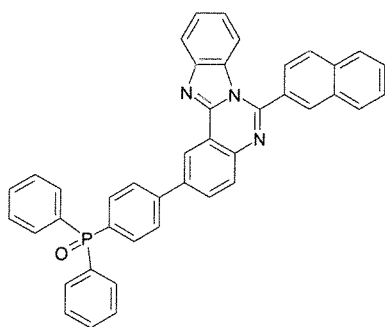

[Formula 1-11]

10

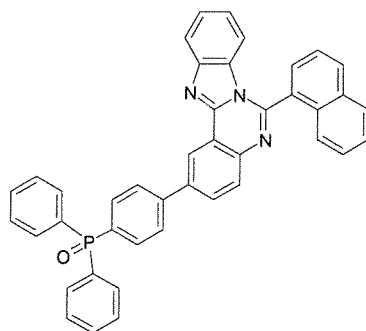

[Formula 1-12]

15

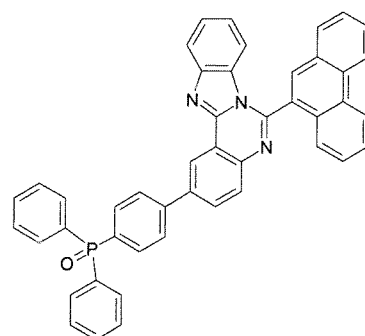

[Formula 1-13]

20

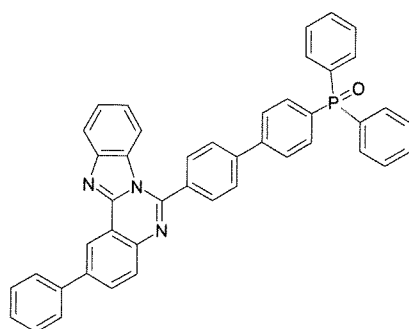

[Formula 1-14]

25

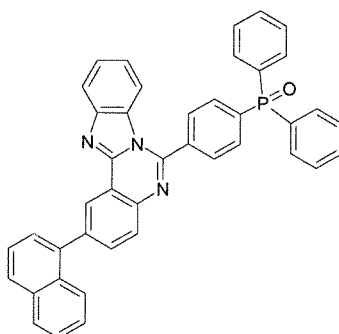

[Formula 1-15]

30

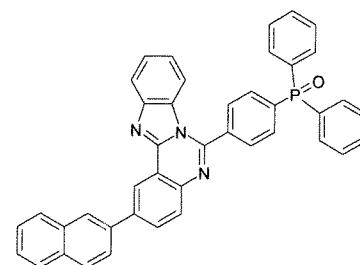

[Formula 1-16]

35

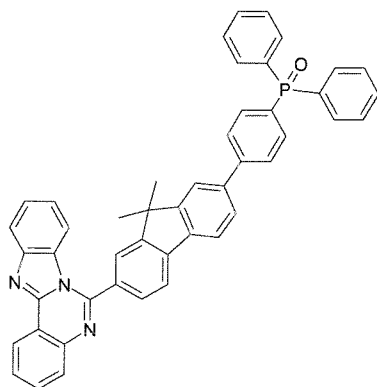

[Formula 1-17]

40

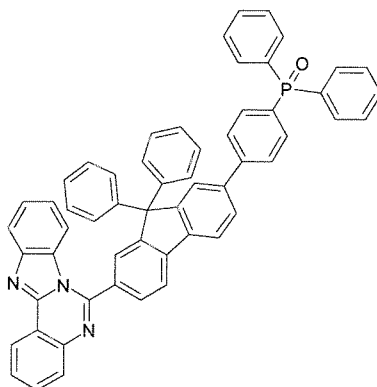

[Formula 1-18]

45

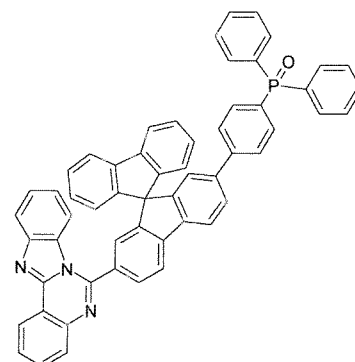

50

55

[Formula 1-19]

5

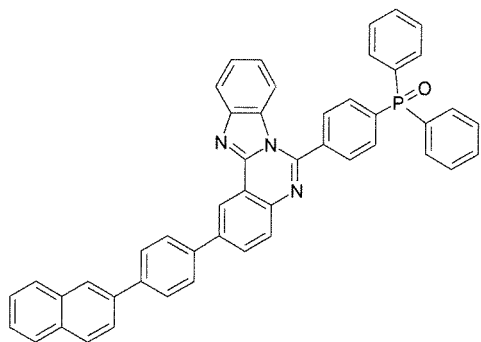

10

15

[Formula 1-20]

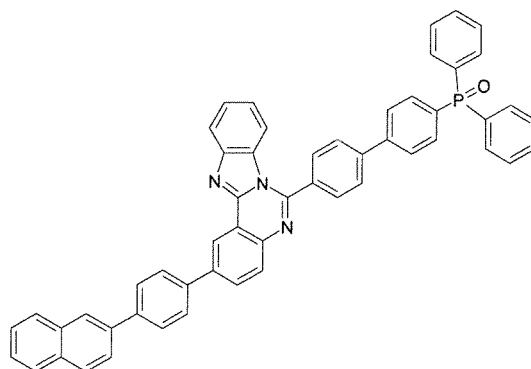

[Formula 1-21]

20

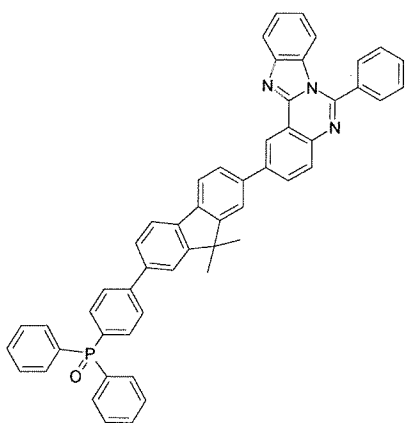

25

30

[Formula 1-22]

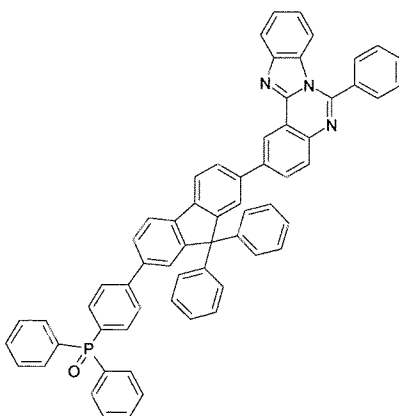

35

[Formula 1-23]

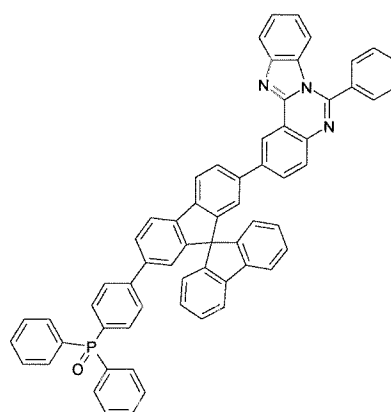

[Formula 1-24]

40

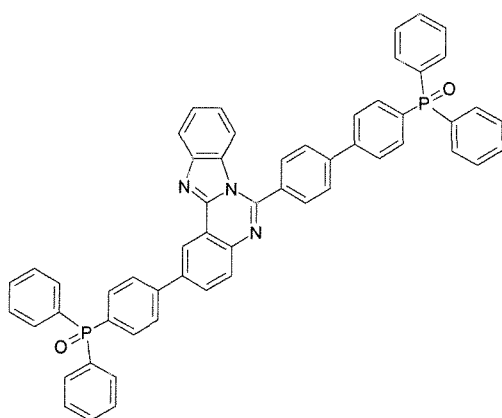

45

50

[Formula 1-25]

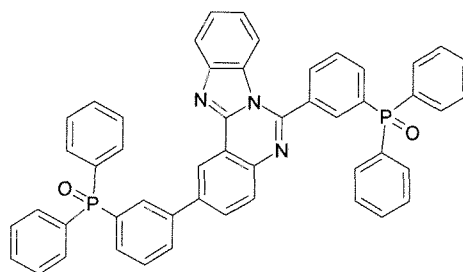

55

[Formula 1-26]

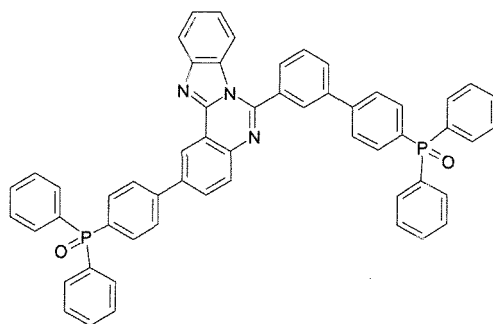

- 5
- 10
- 15 **4.** An organic electronic device, comprising:
- a first electrode;
- a second electrode;
- and one or more organic material layers disposed between the first electrode and the second electrode,
- 20 wherein one or more layers of the organic material layers comprise the compound represented by Formula 1 of any one of claims 1 to 3.
- 25 **5.** The organic electron device of claim 4, wherein the organic material layer comprises one or more layers of a hole injection layer, a hole transporting layer, and a layer which injects and transports holes simultaneously, and one or more layers of the layers comprise the compound represented by Formula 1.
- 30 **6.** The organic electronic device of claim 4, wherein the organic material layer comprises a light emitting layer, and the light emitting layer comprises the compound represented by Formula 1.
- 35 **7.** The organic electron device of claim 4, wherein the organic material layer comprises one or more layers of an electron transporting layer, an electron injection layer, and a layer which transports and injects electrons simultaneously, and one or more layers of the layers comprise the compound represented by Formula 1.
- 8.** The organic electronic device of claim 4, wherein the organic electronic device is selected from the group consisting of an organic light emitting device, an organic phosphorescence device, an organic solar cell, an organic photoconductor (OPC) and an organic transistor.

Patentansprüche

- 40 **1.** Verbindung der nachstehenden Formel 1:
- 45
- 50
- 55

[Formel 1]

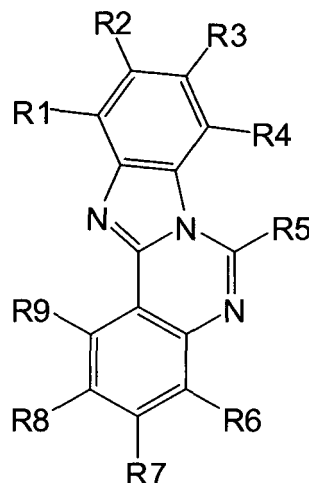

20 worin

25 zumindest eines von R1 bis R9 durch die nachstehende Formel 2 dargestellt ist und der Rest davon Wasserstoff; Deuterium; eine Halogengruppe; eine Nitrilgruppe; eine Nitrogruppe; eine Hydroxylgruppe; eine substituierte oder unsubstituierte Cycloalkylgruppe; eine substituierte oder unsubstituierte Alkoxygruppe; eine substituierte oder unsubstituierte Aryloxygruppe; eine substituierte oder unsubstituierte Alkylthioxygruppe; eine substituierte oder unsubstituierte Arylthioxygruppe; eine substituierte oder unsubstituierte Alkylsulfoxygruppe; eine substituierte oder unsubstituierte Arylsulfoxygruppe; eine substituierte oder unsubstituierte Alkenylgruppe; eine substituierte oder unsubstituierte Silylgruppe; eine substituierte oder unsubstituierte Borgruppe; eine substituierte oder unsubstituierte Alkylamingruppe; eine substituierte oder unsubstituierte Aralkylamingruppe; eine substituierte oder unsubstituierte Arylamingruppe; eine substituierte oder unsubstituierte Heteroarylamingruppe; eine substituierte oder unsubstituierte Arylgruppe; eine substituierte oder unsubstituierte Fluorenylgruppe; eine substituierte oder unsubstituierte Carbazolgruppe oder eine substituierte oder unsubstituierte heterocyclische Gruppe, umfassend eines oder mehrere von N-, O- und S-Atomen, sind;

[Formel 2]

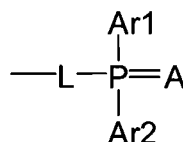

45 L eine direkte Bindung; eine substituierte oder unsubstituierte Arylengruppe oder eine substituierte oder unsubstituierte Heteroarylengruppe, umfassend eines oder mehrere von N-, O- und S-Atomen, ist; Ar1 und Ar2 jeweils unabhängig eine substituierte oder unsubstituierte Arylgruppe oder eine substituierte oder unsubstituierte heterocyclische Gruppe, umfassend eines oder mehrere von N-, O- und S-Atomen, ist; und A O, S oder Se ist.

- 50
- 55
2. Verbindung gemäss Anspruch 1, worin R5 in Formel 1 durch die Formel 2 dargestellt ist.
 3. Verbindung gemäss Anspruch 1, worin die Verbindung der Formel 1 durch irgendeine der nachstehenden Formeln dargestellt ist:

[Formel 1-1]

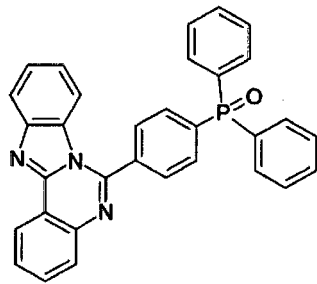

[Formel 1-2]

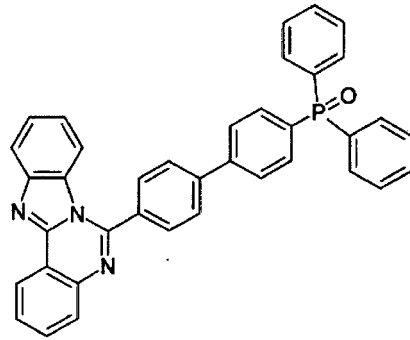

[Formel 1-3]

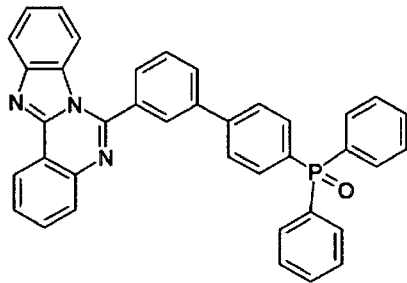

[Formel 1-4]

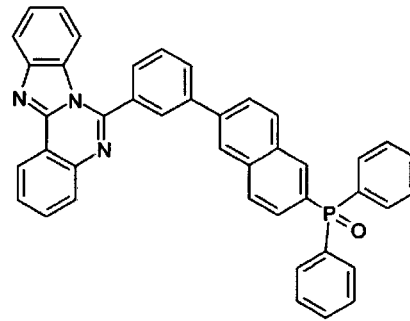

[Formel 1-5]

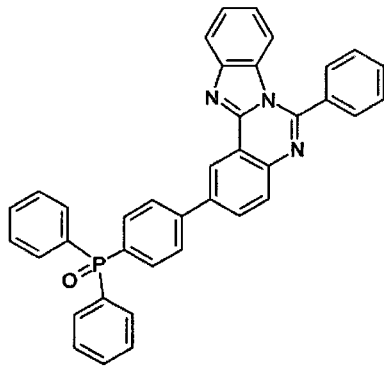

[Formel 1-6]

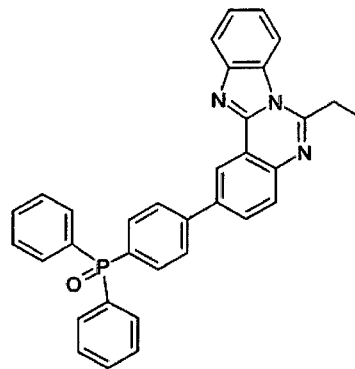

5

10

15

20

25

30

35

40

45

50

55

[Formel 1-7]

5

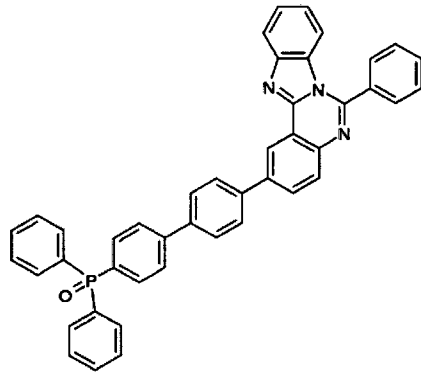

10

15

[Formel 1-8]

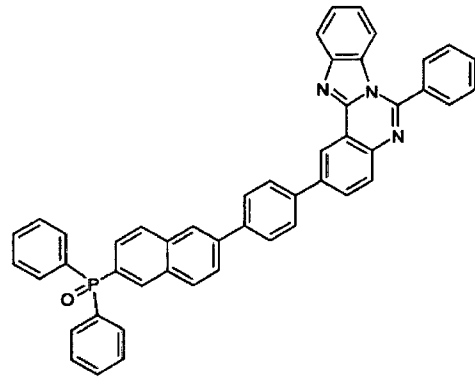

[Formel 1-9]

20

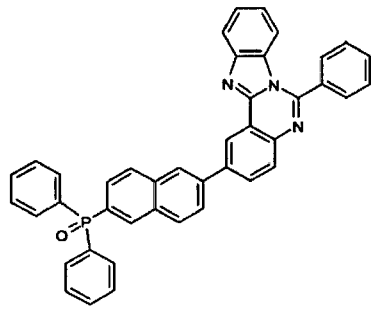

25

30

[Formel 1-10]

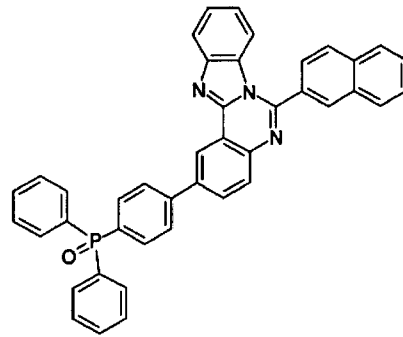

[Formel 1-11]

35

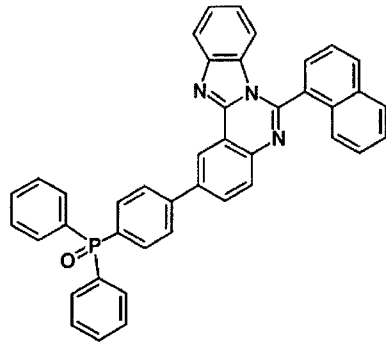

40

45

[Formel 1-12]

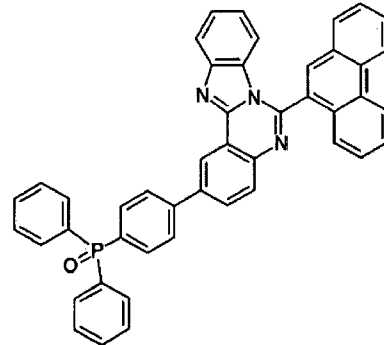

50

55

[Formel 1-13]

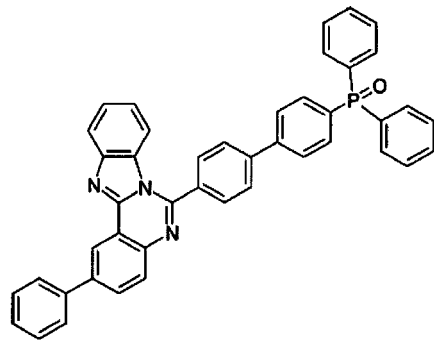

[Formel 1-14]

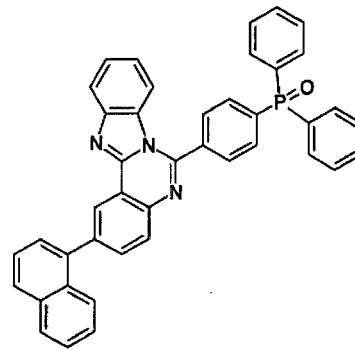

[Formel 1-15]

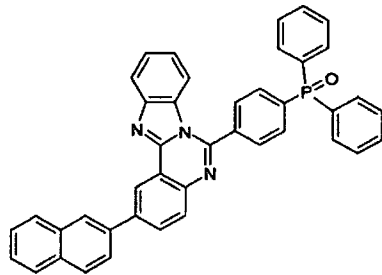

[Formel 1-16]

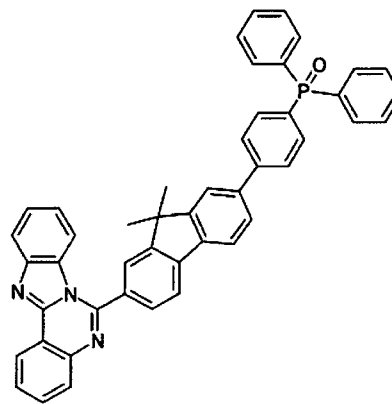

[Formel 1-17]

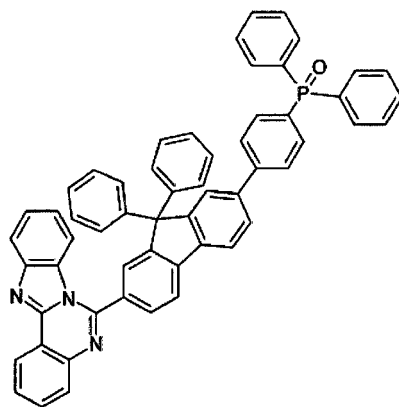

[Formel 1-18]

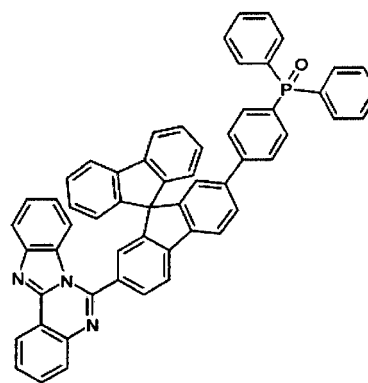

[Formel 1-19]

5

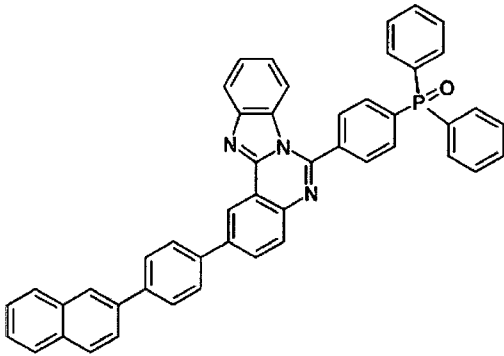

10

15

[Formel 1-20]

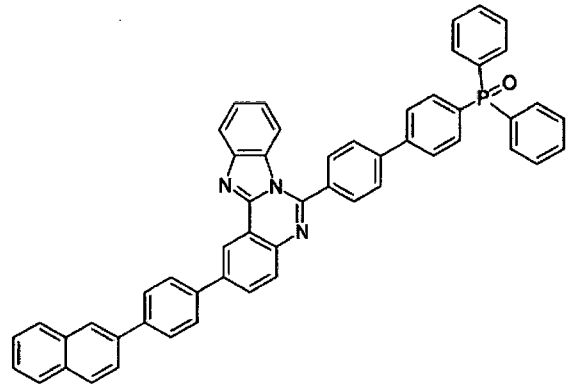

[Formel 1-21]

20

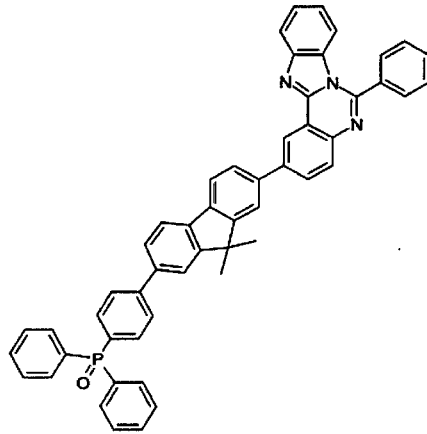

25

30

35

[Formel 1-22]

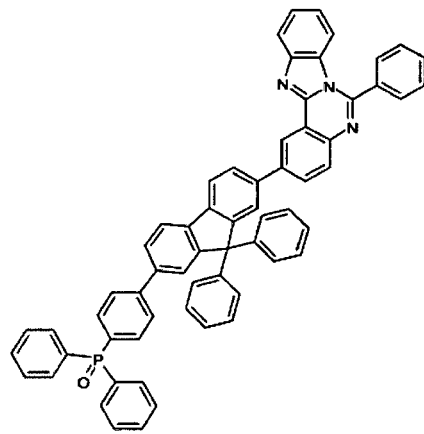

40

45

50

[Formel 1-23]

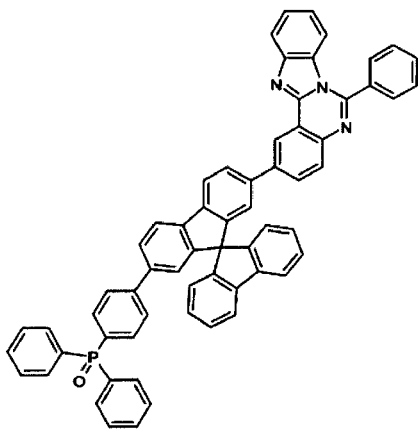

55

[Formel 1-24]

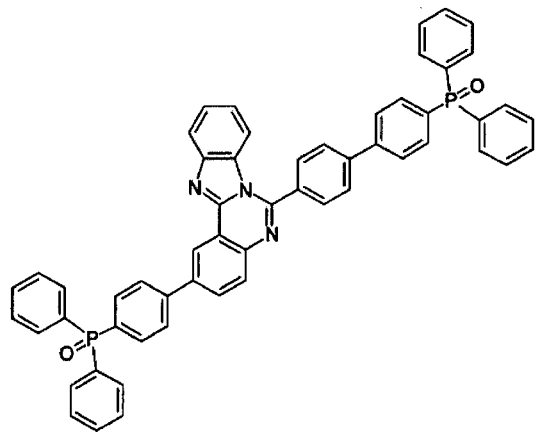

[Formel 1-25]

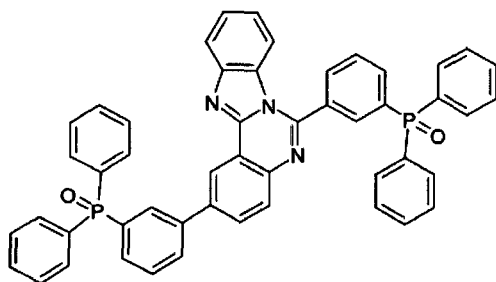

[Formel 1-26]

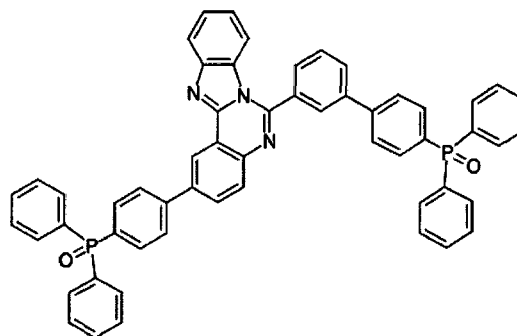

4. Organische elektronische Vorrichtung, umfassend:

eine erste Elektrode;

eine zweite Elektrode;

und eine oder mehrere organische Materialschicht(en), die zwischen der ersten Elektrode und der zweiten Elektrode angeordnet ist/sind,

wobei eine oder mehrere Schichten der organischen Materialschichten eine Verbindung der Formel 1 gemäss irgendeinem der Ansprüche 1 bis 3 umfasst/umfassen.

5. Organische elektronische Vorrichtung gemäss Anspruch 4, wobei die organische Materialschicht eine oder mehrere Schichten von einer Lochinjektionsschicht, einer Lochtransportschicht und einer Schicht, die Löcher gleichzeitig injiziert und transportiert, umfasst und eine oder mehrere Schicht(en) der Schichten eine Verbindung der Formel 1 umfasst/umfassen.

6. Organische elektronische Vorrichtung gemäss Anspruch 4, wobei die organische Materialschicht eine lichtemittierende Schicht umfasst und die lichtemittierende Schicht eine Verbindung der Formel 1 umfasst.

7. Organische elektronische Vorrichtung gemäss Anspruch 4, wobei die organische Materialschicht eine oder mehrere Schicht(en) von einer Elektronentransportschicht, einer Elektroneninjectionsschicht und einer Schicht, die Elektronen gleichzeitig transportiert und injiziert, umfasst und eine oder mehrere Schicht(en) der Schichten eine Verbindung der Formel 1 umfasst/umfassen.

8. Organische elektronische Vorrichtung gemäss Anspruch 4, wobei die organische elektronische Vorrichtung aus der Gruppe bestehend aus einer organischen lichtemittierenden Vorrichtung, einer organischen Phosphoreszenzvorrichtung, einer organischen Solarzelle, einem organischen Fotoleiter (organic photoconductor; OPC) und einem organischen Transistor ausgewählt ist.

Revendications

1. Composé représenté par la formule 1 suivante :

[Formule 1]

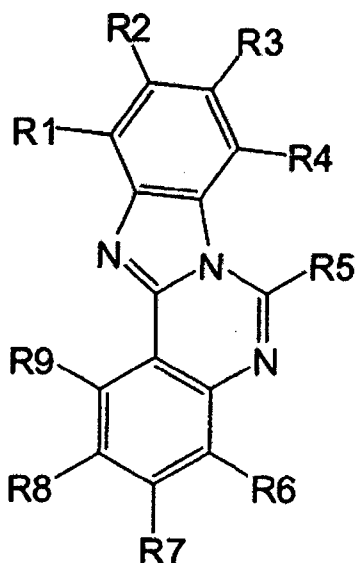

dans laquelle :

25

30

35

au moins l'un de R1 à R9 est représenté par la formule 2 suivante et le reste de celle-ci est un atome d'hydrogène ; un atome de deutérium ; un groupement halogéno ; un groupement nitrile ; un groupement nitro ; un groupement hydroxyle ; un groupement cycloalkyle substitué ou non substitué ; un groupement alcoxy substitué ou non substitué ; un groupement aryloxy substitué ou non substitué ; un groupement alkylthioxy substitué ou non substitué ; un groupement arylthioxy substitué ou non substitué ; un groupement alkylsulfoxy substitué ou non substitué ; un groupement arylsulfoxy substitué ou non substitué ; un groupement alcényle substitué ou non substitué ; un groupement silyle substitué ou non substitué ; un groupement bore substitué ou non substitué ; un groupement alkylamine substitué ou non substitué ; un groupement aralkylamine substitué ou non substitué ; un groupement arylamine substitué ou non substitué ; un groupement hétéroarylamine substitué ou non substitué ; un groupement aryle substitué ou non substitué ; un groupement fluorényle substitué ou non substitué ; un groupe carbazole substitué ou non substitué ; ou un groupement hétérocyclique substitué ou non substitué comprenant un ou plus d'atomes de N, O et S ;

[Formule 2]

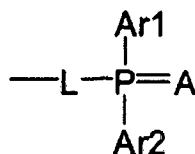

50

55

L est une liaison directe ; un groupement arylène substitué ou non substitué ; ou un groupement hétéroarylène substitué ou non substitué comprenant un ou plus d'atomes de N, O et S,
Ar1 et Ar2 sont chacun indépendamment un groupement aryle substitué ou non substitué ; ou un groupement hétérocyclique substitué ou non substitué comprenant un ou plus d'atomes de N, O et S ;
et
A est O, S ou Se.

2. Composé selon la revendication 1, dans lequel R5 dans la formule 1 est représenté par la formule 2.

3. Composé selon la revendication 1, dans lequel le composé représenté par la formule 1 est représenté par l'une quelconque des formules suivantes :

[Formule 1-1]

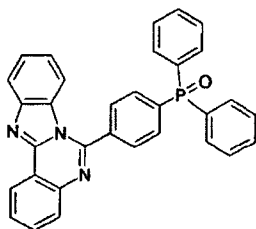

[Formule 1-2]

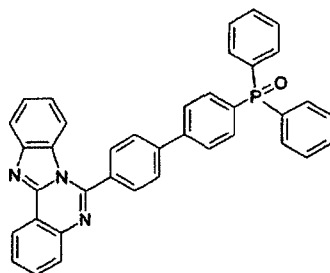

[Formule 1-3]

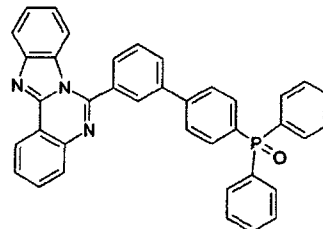

[Formule 1-4]

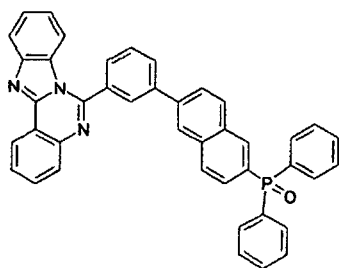

[Formule 1-5]

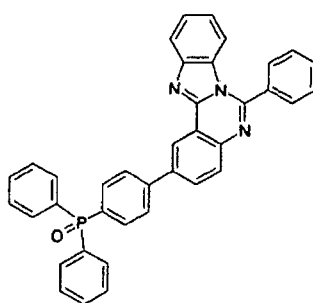

[Formule 1-6]

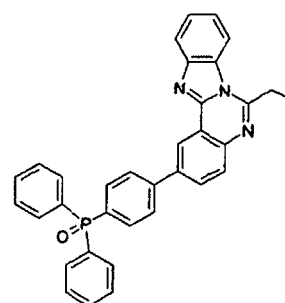

[Formule 1-7]

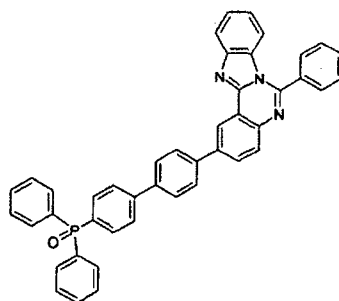

[Formule 1-8]

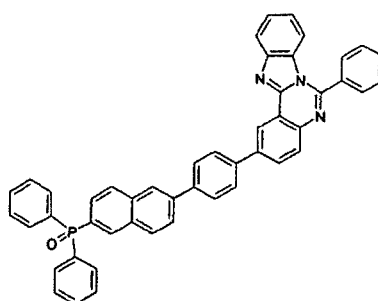

[Formule 1-9]

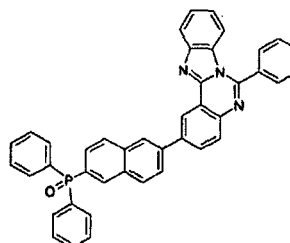

[Formule 1-10]

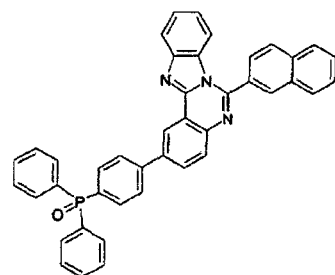

[Formule 1-11] [Formule 1-12]

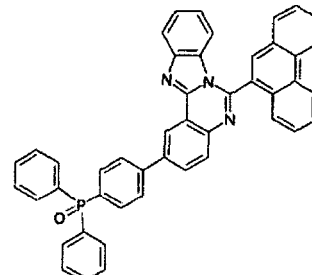
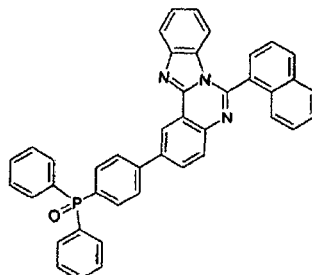

[Formule 1-13]

5

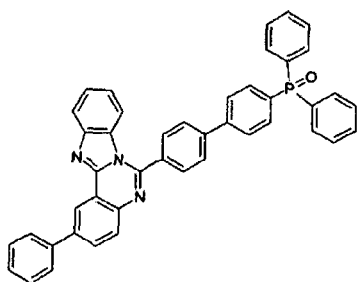

[Formule 1-14]

10

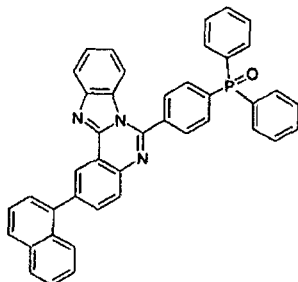

[Formule 1-15]

15

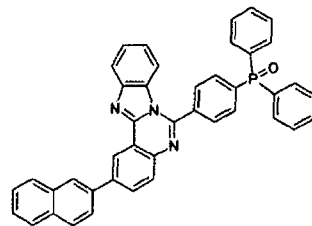

[Formule 1-16]

20

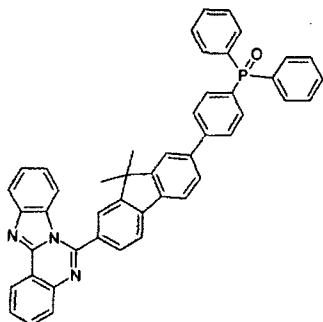

[Formule 1-17]

25

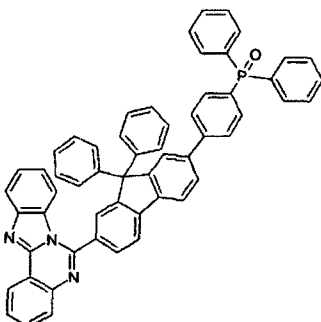

[Formule 1-18]

30

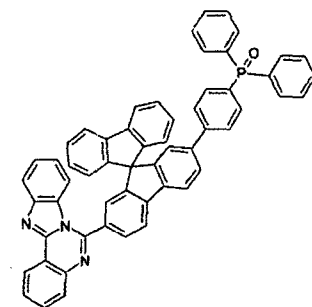

[Formule 1-19]

35

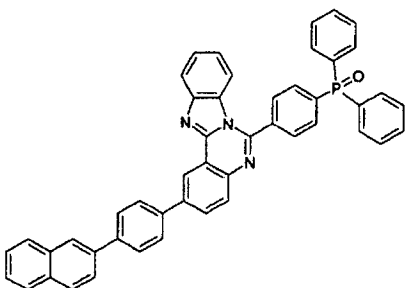

[Formule 1-20]

40

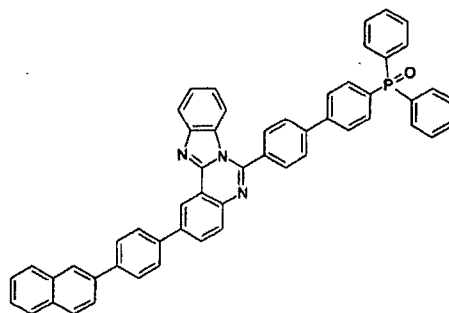

[Formule 1-21]

45

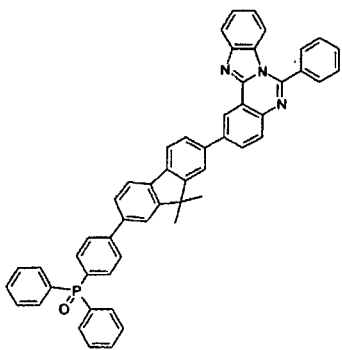

[Formule 1-22]

50

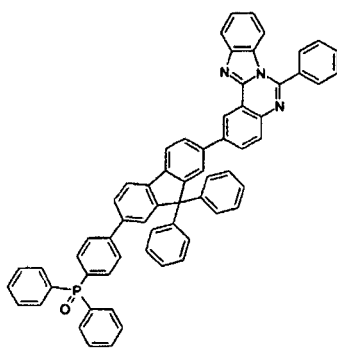

[Formule 1-23]

55

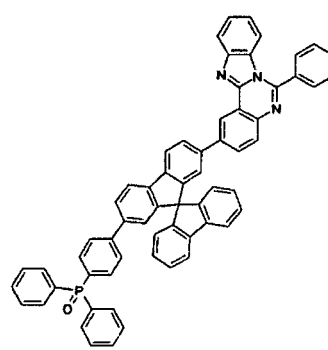

[Formule 1-24]

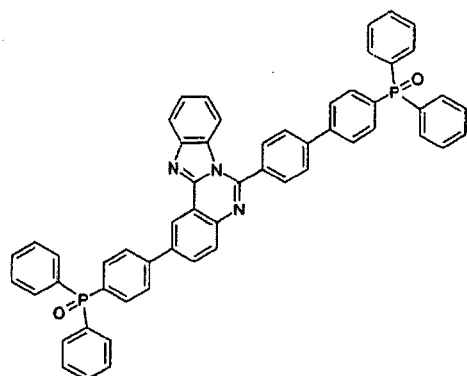

[Formule 1-25]

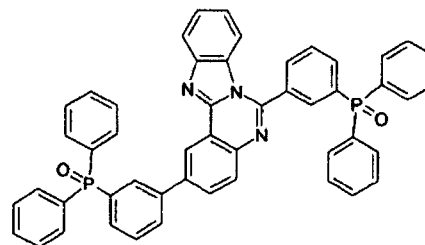

[Formule 1-26]

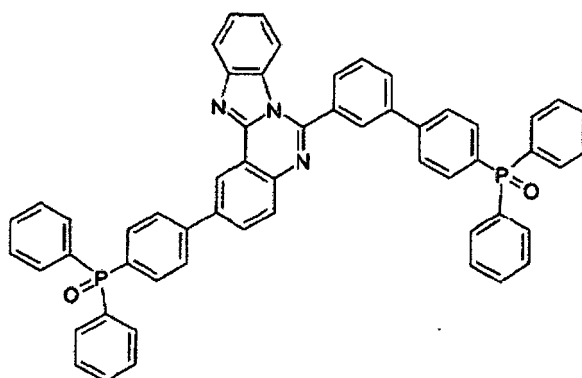

4. Dispositif électronique organique, comprenant :

une première électrode ;
 une seconde électrode ;
 et une ou plusieurs couches de matériau organique disposées entre la première électrode et la seconde électrode,
 dans lequel une ou plusieurs couches des couches de matériau organique comprennent le composé représenté par la formule 1 selon l'une quelconque des revendications 1 à 3.

5. Dispositif électronique organique selon la revendication 4, dans lequel la couche de matériau organique comprend une ou plusieurs couches parmi une couche d'injection de trous, une couche de transport de trous et une couche qui injecte et transporte des trous simultanément et une ou plusieurs des couches comprennent le composé représenté par la formule 1.

6. Dispositif électronique organique selon la revendication 4, dans lequel la couche de matériau organique comprend une couche électroluminescente et la couche électroluminescente comprend le composé représenté par la formule 1.

7. Dispositif électronique organique selon la revendication 4, dans lequel la couche de matériau organique comprend une ou plusieurs couches parmi une couche de transport d'électrons, une couche d'injection d'électrons et une couche qui transporte et injecte des électrons simultanément, et une ou plusieurs des couches comprennent le composé représenté par la formule 1.

8. Dispositif électronique organique selon la revendication 4, le dispositif électronique organique étant choisi dans le groupe constitué d'un dispositif organique électroluminescent, d'un dispositif organique phosphorescent, d'une cellule solaire organique, d'un photoconducteur organique (PCO) et d'un transistor organique.

[Figure 1]

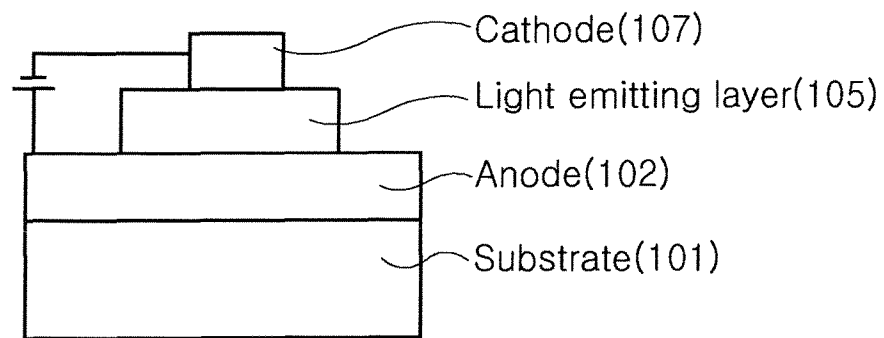

[Figure 2]

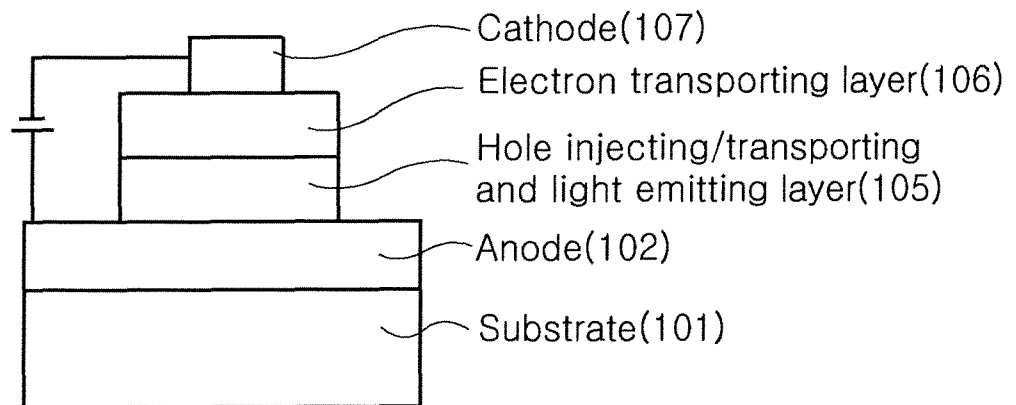

[Figure 3]

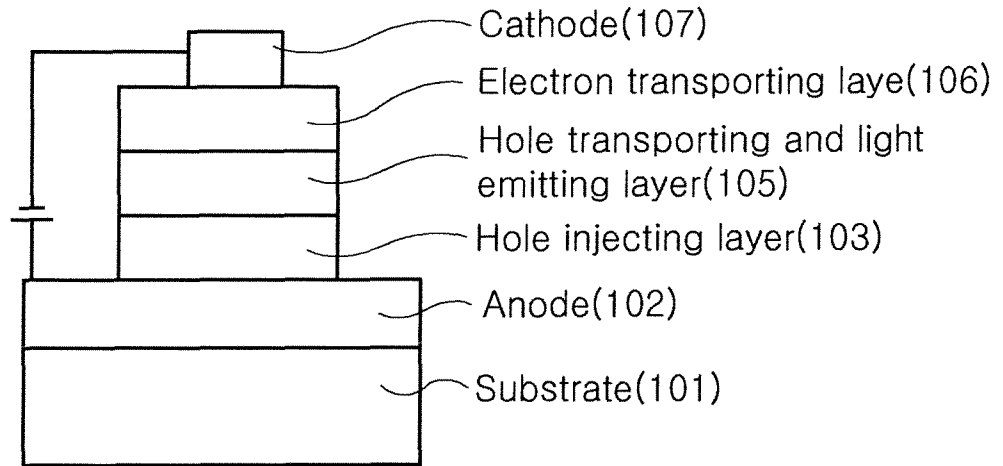

[Figure 4]

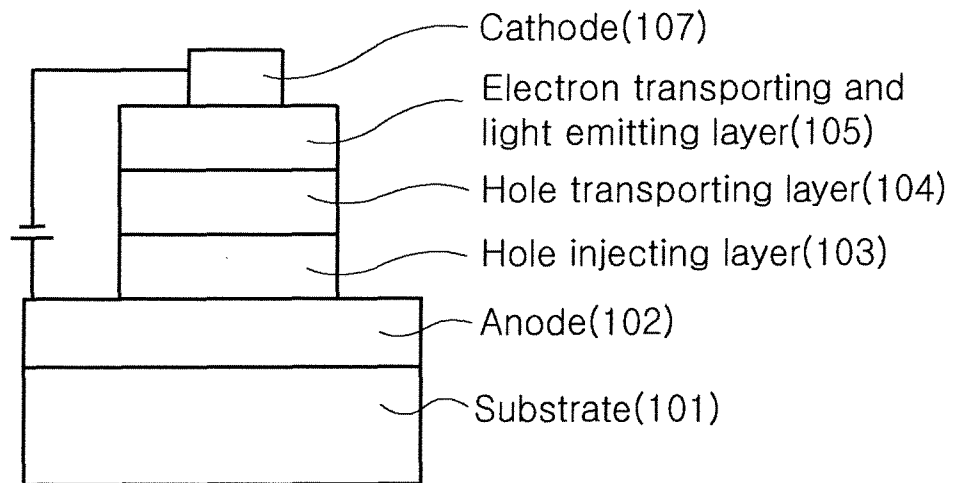

REFERENCES CITED IN THE DESCRIPTION

This list of references cited by the applicant is for the reader's convenience only. It does not form part of the European patent document. Even though great care has been taken in compiling the references, errors or omissions cannot be excluded and the EPO disclaims all liability in this regard.

Patent documents cited in the description

- KR 1020110056777 [0001]
- WO 2007069847 A [0009]
- WO 2011010842 A [0009]
- KR 20060109524 [0009]

专利名称(译)	新型化合物和使用它的有机电子器件		
公开(公告)号	EP2719741B1	公开(公告)日	2016-04-13
申请号	EP2012799893	申请日	2012-06-12
[标]申请(专利权)人(译)	乐金化学股份有限公司		
申请(专利权)人(译)	LG化学有限公司.		
当前申请(专利权)人(译)	LG化学有限公司.		
[标]发明人	SHIN CHANGHWAN KIM KONGKYEOM LEE DONG HOON JANG JUNGI CHUN MINSEUNG		
发明人	SHIN, CHANGHWAN KIM, KONGKYEOM LEE, DONG HOON JANG, JUNGI CHUN, MINSEUNG		
IPC分类号	C09K11/06 C07D471/04 C07F9/28 H01L51/50 H01L51/00 C07D487/04 H05B33/10 C09B57/00		
CPC分类号	C07D487/04 C07F9/6561 C09B57/00 C09K11/06 C09K2211/1007 C09K2211/1011 C09K2211/1014 C09K2211/1044 H01L51/0052 H01L51/0058 H01L51/006 H01L51/0068 H01L51/0072 H01L51/0077 H01L51/0081 H01L51/5072 H05B33/10 Y02E10/549 Y10S428/917 H01L51/0062 H01L51/5056 H01L51/5088 H01L51/5092		
优先权	1020110056777 2011-06-13 KR		
其他公开文献	EP2719741A4 EP2719741A2		
外部链接	Espacenet		

摘要(译)

本发明提供新化合物和使用其的有机电子器件。根据本发明的化合物可以在包括有机发光器件的有机电子器件中用作空穴注入，空穴传输，电子注入和传输，以及发光材料等，并且根据本发明的有机电子器件在效率，驱动电压和使用寿命方面表现出优异的性能。

[Formula 1]

