



(11) **EP 1 505 666 B1**

(12) **EUROPEAN PATENT SPECIFICATION**

(45) Date of publication and mention of the grant of the patent:
04.04.2018 Bulletin 2018/14

(51) Int Cl.:
H01L 27/32^(2006.01) H01L 51/52^(2006.01)

(21) Application number: **04018107.5**

(22) Date of filing: **30.07.2004**

(54) **Top-emission active matrix organic electroluminescent display device and method for fabricating the same**

NACH OBEN ABSTRAHLENDE ORGANISCHE ELEKTROLUMINESZENTE ANZEIGEVORRICHTUNG MIT AKTIVER MATRIX UND VERFAHREN ZU DEREN HERSTELLUNG
DISPOSITIF ELECTROLUMINESCENT ORGANIQUE A MATRICE ACTIVE EMETTANT PAR LE HAUT ET METHODE POUR SA FABRICATION

(84) Designated Contracting States:
DE FR GB NL

(30) Priority: **05.08.2003 KR 2003054149**
05.08.2003 KR 2003054150

(43) Date of publication of application:
09.02.2005 Bulletin 2005/06

(73) Proprietor: **LG Display Co., Ltd.**
Seoul, 07336 (KR)

(72) Inventor: **Kim, Hong Gyu**
Uiwang-si
Gyeonggi-do (KR)

(74) Representative: **Ter Meer Steinmeister & Partner**
Patentanwälte mbB
Nymphenburger Straße 4
80335 München (DE)

(56) References cited:
EP-A- 1 122 800 EP-A- 1 160 891
EP-A- 1 191 820 EP-A- 1 274 130
US-A1- 2002 158 835

- **PATENT ABSTRACTS OF JAPAN vol. 2003, no. 02, 5 February 2003 (2003-02-05) -& JP 2002 318556 A (TOSHIBA CORP), 31 October 2002 (2002-10-31)**

EP 1 505 666 B1

Note: Within nine months of the publication of the mention of the grant of the European patent in the European Patent Bulletin, any person may give notice to the European Patent Office of opposition to that patent, in accordance with the Implementing Regulations. Notice of opposition shall not be deemed to have been filed until the opposition fee has been paid. (Art. 99(1) European Patent Convention).

Description

BACKGROUND OF THE INVENTION

Field of the Invention

[0001] The present invention relates to an active matrix electroluminescence device and a method for fabricating the same. Although the present invention is suitable for a wide scope of applications, it is particularly suitable for enhancing the luminous efficiency and improving the electrical function of the device.

Discussion of the Related Art

[0002] An electroluminescence device is being viewed as a next generation flat display device for its characteristics of a wide viewing angle, a high aperture ratio, and a high chromaticity. More specifically, in an organic electroluminescence (EL) device, when an electric charge is injected into an organic electroluminous layer formed between a hole injection electrode and an electron injection electrode, the electron and the hole are paired to each other generating an exciton, the excited state of which falls to a ground state, thereby emitting light. Thus, the organic electroluminescence device (ELD) can be operated at a lower voltage, as compared to other display devices.

[0003] Depending upon the driving method, the organic ELD can be classified into a passivation ELD and an active matrix ELD. The passivation ELD is formed of a transparent electrode on a transparent substrate, an organic electroluminous layer on the transparent electrode, and a cathode electrode on the organic electroluminous layer. The active matrix ELD is formed of a plurality of scan lines and data lines defining a pixel area on a substrate, a switching device electrically connecting the scan lines and the data lines and controlling the electroluminescence device, a transparent electrode (*i.e.*, anode) electrically connected to the switching device and formed in the pixel area on the substrate, an organic electroluminous layer on the transparent electrode, and a metal electrode (*i.e.*, cathode) on the organic electroluminous layer. Unlike the passivation ELD, the active matrix ELD further includes the switching device, which is a thin film transistor (TFT).

[0004] The active matrix ELD can be categorized into two types: a top-emission ELD and a bottom-emission ELD. Unlike the bottom-emission ELD, since the top-emission ELD emits light rays towards a metal common electrode (*i.e.*, cathode), the metal common electrode of the top-emission ELD should be formed in a thin layer in order to provide a highly efficient light transmission.

[0005] However, if the metal common electrode is formed too thin, the heat applied thereon may cause the metal common electrode to be short-circuited or oxidized. Due to the characteristics of the active matrix ELD, a large amount of electric current constantly flows within

the metal common electrode. More specifically, when the metal common electrode is formed of silver (Ag), lumps are formed on the metal common electrode because of the migration of the silver (Ag) atoms. Thus, the reliability of the device is lowered and the durability is reduced.

[0006] US 2002/0158835 A1 describes a display device and a method for fabricating the same wherein the display device is an active matrix type planar display device having: an insulative substrate including a thin film transistor and a pixel area defined thereon; a first insulating layer formed on the substrate and the thin film transistor; a first electrode formed on the first insulating layer of the pixel area and connected to the thin film transistor through a contact hole within the first insulating layer; a second electrode formed on the first insulating layer adjacent to the first electrode, wherein the second electrode is formed of the same material and layer with the first electrode on the first insulating layer; a second insulating layer formed on a predetermined area of the first electrode and the second electrode wherein the second insulating layer includes a trench formed along a direction of the second electrode; an emission layer formed on the first electrode in the pixel area; and a third electrode formed on the emission layer and electrically connected to the second electrode through the trench.

[0007] EP 1 122 800 A2 discloses an electroluminescence element that comprises a reflecting electrode, an anode, an electroluminescence layer, a cathode, and an auxiliary electrode. The cathode is made from a metallic film whereas the auxiliary electrode is formed as a transparent conductive film.

[0008] EP 1 274 130 A2 is concerned with an organic EL display device and a method for fabricating the same and shows the use of a shadow mask for forming organic luminescence layers.

[0009] EP 1 160 891 A2 is concerned with a low-voltage organic light-emitting device and discloses a light-emitting element having a transparent substrate, a hole injection electrode, a hole transport layer, a light-emitting layer, an interface structure, an electron transporting layer, and an electron injecting electrode.

SUMMARY OF THE INVENTION

[0010] The object underlying the present invention is to provide an improved active matrix electroluminescence device that has an increased durability and an enhanced reliability, as well as a method for fabricating the same.

[0011] This object is achieved by the device of claim 1 and the method of claim 6.

BRIEF DESCRIPTION OF THE DRAWINGS

[0012] The accompanying drawings, which are included to provide a further understanding of the invention and are incorporated in and constitute a part of this application, illustrate embodiments of the invention and together

with the description serve to explain the principle of the invention. In the drawings;

FIG. 1 illustrates a plane view of an active matrix electroluminescence device according to the present invention;

FIG. 2 illustrates a cross-sectional view taken along line B-B' of FIG. 1;

FIGs. 3A to 3G illustrate the process steps of a method for fabricating the active matrix electroluminescence device according to a first embodiment of the present invention;

FIG. 4 illustrates a shadow mask according to the present invention; and

FIG. 5A to 5F illustrate the process steps of a method for fabricating the active matrix electroluminescence device according to a second embodiment not forming part of the present invention.

DETAILED DESCRIPTION OF THE INVENTION

[0013] Reference will now be made in detail to the preferred embodiments of the present invention, examples of which are illustrated in the accompanying drawings. Wherever possible, the same reference numbers will be used throughout the drawings to refer to the same or like parts.

[0014] FIG. 1 illustrates a plane view of an active matrix electroluminescence device according to the present invention.

[0015] Referring to FIG. 1, the top-emission active matrix electroluminescence device (ELD) according to the present invention includes red (R), green (G), and blue (B) organic electroluminescent layer 34, 34', and 34" formed on a pixel area, and a counter common electrode 29 formed in a stripe form on an area outside of the pixel area having the R, G, and B organic electroluminescent layers formed thereon. Generally, in the active matrix ELD, a shadow mask is always used when forming the R, G, and B organic electroluminescent layers 34, 34', and 34". Herein, the thickness of a bridge of the shadow mask in the range of about 40 to 50 micrometers (μm), which is a space wide enough to form the counter common electrode 29. Since region D of FIG. 1 corresponds to the bridge area of the shadow mask, in the present invention, the counter common electrode 29 is formed in the D region.

[0016] The counter common electrode 29 is electrically connected to a common electrode 37 and 38 (*i.e.*, a cathode) through an aperture of an insulating layer 30. And so, most of the electric current flowing through the common electrode 37 and 38 flows to the outside through the counter common electrode 29, which has a lower resistance, thereby resolving the problem of resistance in the common electrode.

[0017] FIG. 2 illustrates a cross-sectional view taken along line B-B' of FIG. 1. The top-emission active matrix electroluminescence device according to the present in-

vention will now be described with reference to FIG. 2.

[0018] Referring to FIG. 2, a pixel electrode 28, and a plurality of common electrodes 37 and 38 crossing over the pixel electrode 28 are formed on a glass substrate 21. The common electrode 37 and 38 include a metal common electrode 37 and a transparent common electrode 38 deposited thereon. In addition, an organic electroluminescent layer 34 is formed between the pixel electrode 28 and the common electrode 37 and 38. Herein, the organic electroluminescent layer 34 is formed in the pixel area.

[0019] Additionally, a thin film transistor B is formed on the glass substrate 21 and is electrically connected to the pixel electrode 28. The thin film transistor B includes a semiconductor layer 22 formed on a region of the glass substrate 21 and including source and drain areas 22a and 22b and a channel area 22c, a gate insulating layer 23 formed on the entire surface of the semiconductor layer 22 and the glass substrate 21, a gate electrode 24 formed on the gate insulating layer 23 over the channel area 22c. Herein, the boundaries of the source and drain areas 22a and 22b and the channel area 22c are aligned with both edges of the gate electrode 24.

[0020] Moreover, an interlayer dielectric 25 is formed on the thin film transistor B. The interlayer dielectric 25 includes a plurality of contact holes exposing a portion of the surface of the source and drain areas 22a and 22b. A plurality of electrode lines 26 are formed in the contact holes, so as to be electrically connected to the source and drain areas 22a and 22b.

[0021] A planarization insulating layer 27 is formed on the entire surface of the interlayer dielectric 25 and the electrode line 26. The planarization insulating layer 27 includes a via hole exposing a portion of the surface of the electrode line 26 connected to the drain area 22b. The pixel electrode 28 is formed on the pixel area of the planarization insulating layer 27. Herein, the pixel electrode 28 is electrically connected to the drain area 22b of the thin film transistor B through the via hole of the planarization insulating layer 27.

[0022] A counter common electrode 29 is formed in a stripe form outside of the pixel area of the planarization insulating layer 27 and in a direction parallel to the length of the gate electrode 24 of the thin film transistor B.

[0023] An insulating layer 30 formed between the pixel electrode 28 and the counter common electrode 29 overlaps a portion of the pixel electrode 28 and a portion of the counter common electrode 29. The insulating layer 30 is formed to electrically insulate the pixel electrode 28 and the counter common electrode 29, the insulating layer 30 being formed in an area outside of the pixel area.

[0024] A hole injection layer 32 and a hole transport layer 33 are serially formed on the pixel electrode 28 and the insulating layer 30, and an organic electroluminescent layer 34 is formed on the pixel area of the hole transport layer 33. The organic electroluminescent layer 34 includes red (R), green (G), and blue (B) organic electroluminescent layers 34, 34', and 34" depending upon the emitted color.

The R, G, and B organic electroluminous layers 34, 34', and 34" are serially formed on each of the corresponding pixel areas. Subsequently, an electron transport layer 35 and an electron injection layer 36 are serially deposited on the organic electroluminous layer 34 and the hole transport layer 33.

[0025] A metal common electrode 37 and a transparent common electrode 38 are formed on the counter common electrode 29, a portion of the insulating layer 30, and the electron injection layer 36, and a protective layer 39 is formed on the entire surface of the transparent common electrode 38. Herein, since the insulating layer 30, the hole injection layer 32, the hole transport layer 33, the organic electroluminous layer 34, the electron transport layer 35, and the electron injection layer 36 are not formed on the counter common electrode 29, the common electrodes 37 and 38 are contacted with the counter common electrode 29. Alternatively, in the present invention, the metal common electrode 37 can be omitted, thereby allowing the transparent common electrode 38 to be directly contacted with the counter common electrode 39.

[0026] The method for fabricating the top-emission active matrix electroluminescence device according to the present invention will now be described with reference to the following drawings.

First Embodiment

[0027] FIGs. 3A to 3G illustrate the process steps of a method for fabricating the active matrix electroluminescence device according to a first embodiment of the present invention. Referring to FIG. 3A, in order to be used as an active layer of the thin film transistor B, the semiconductor layer 22 is formed on the glass substrate 21 by using a polycrystalline silicon. Subsequently, the semiconductor layer 22 is patterned to leave only a portion of the semiconductor layer 22, corresponding to the area on which the thin film transistor B is to be formed. Then, the gate insulating layer 23 is deposited on the entire surface of the glass substrate 21 and the semiconductor layer 22, and a conductive material layer is deposited on the gate insulating layer 23, so as to form the gate electrode. The conductive material layer is patterned so that only a predetermined portion remains on the patterned semiconductor layer 22, thereby forming the gate electrode 24.

[0028] Thereafter, the gate electrode 24 is used as a mask for injecting impurities, such as boron (B) or potassium (P), the semiconductor layer 22, which is then processed with heat-treatment, thereby forming the source and drain areas 22a and 22b of the thin film transistor B. And, the area of the semiconductor layer 22 having no impurities injected therein becomes the channel area 22c. Herein, since the impurities are injected by using the gate electrode 24 as the mask, the boundaries of the source and drain areas 22a and 22b and the boundary of the channel area 22c are aligned with both edges of

the gate electrode 24.

[0029] The interlayer dielectric 25 is formed on the gate insulating layer 23 and the gate electrode 24. Then, the interlayer dielectric 25 and the gate insulating layer 23 are selectively etched, so as to expose a portion of the upper surface of the source and drain areas 22a and 22b, thereby forming the contact holes. And, the contact holes are filled with metal, so as to form the electrode lines 26 each electrically contacting the source and drain areas 22a and 22b.

[0030] Subsequently, an insulating material is deposited on the interlayer dielectric 25 and the electrode lines 26 by using a spin-coating method, thereby depositing the planarization insulating layer 27. The planarization insulating layer 27 is then hardened through a pre-baking process. Furthermore, the planarization insulating layer 27 is selectively removed to expose the electrode line 26 connected to the drain area 22b of the thin film transistor B, thereby forming the via hole.

[0031] A metallic material layer is deposited on the entire surface of the via hole and the planarization insulating layer 27. In the bottom-emission ELD, the metallic material layer is formed of a transparent material, such as indium-tin-oxide (ITO). Conversely, in the top-emission ELD, the metallic material layer is formed of a metal having high reflectivity and work function. More specifically, in this case, the metallic material layer is formed of one of or an alloy of chrome (Cr), aluminum (Al), molybdenum (Mo), and silver (Ag)-gold (Au) alloy, and a multi-layer can be formed by using such metals. The metallic material layer deposited on the inner layer of the via hole of the planarization insulating layer 27, is connected to the electrode line 26 formed at the bottom of the via hole.

[0032] The metallic material layer is selectively removed so as to form a pixel electrode 28 in each pixel area. And, simultaneously, the counter common electrode 29 is formed in the area outside of the pixel area. The counter common electrode 29 is formed between and spaced apart from the pixel electrodes 28 at a predetermined distance. In other words, the counter common electrode 29 is formed at the boundary area between each pixel electrode on the planarization insulating layer 27. Also, as shown in FIG. 1, the counter common electrode 29 is formed in a stripe form over the thin film transistor B and parallel to the gate electrode 24 of the thin film transistor B.

[0033] Referring to FIG. 3B, after depositing an insulating material on the entire surface of the planarization insulating layer 27, the pixel electrodes 28, the counter common electrode 29, the insulating material layer is selectively removed, so as to form the insulating layer 30 on an area excluding the pixel area, more specifically, on the boundary area between the pixel areas. At this point, the insulating layer 30 is also not formed on a portion of the surface of the counter common electrode 29. In other words, the insulating layer 30 formed between the pixel electrode 28 and the counter common electrode 29 overlaps only a portion of each of the pixel electrode

28 and the counter common electrode 29. In order to expose a portion of the surface of the counter common electrode 29, the insulating layer 30 includes a trench formed on the counter common electrode 29 in the same direction as the length the counter common electrode 29.

[0034] Subsequently, an emission layer is formed on the pixel electrode 28. Herein, the emission layer is formed of the hole injection layer 32, the hole transport layer 33, the organic electroluminescent layer 34, the electron transport layer 35, and the electron injection layer 36 serially deposited thereon. Referring to FIG. 3C, the shadow mask 31 is used to serially deposit the hole injection layer 32 and the hole transport layer 33 on the pixel electrode 28 and the insulating layer 30. The hole injection layer 32 and the hole transport layer 33 is not necessarily deposited on the counter common electrode 29. FIG. 4 illustrates a portion of the surface of the shadow mask 31. Herein, the shadow mask 31 has a plurality of stripes being aligned with a pattern of the counter common electrode 29.

[0035] Referring to FIG. 3D, a shadow mask (not shown) is used to deposit the hole transport layer 33 on the organic electroluminescent layer 34. The organic electroluminescent layer 34 includes red (R), green (G), and blue (B) organic electroluminescent layers 34, 34', and 34" depending upon the emitted color. The R, G, and B organic electroluminescent layers 34, 34', and 34" are serially formed on each of the corresponding pixel areas. Herein, the organic electroluminescent layer 34 is deposited only in the pixel area.

[0036] As shown in FIG. 3E, the shadow mask 31 is used to serially deposit the electron transport layer 35 and the electron injection layer 36 on a portion of the hole transport layer 33 and the organic electroluminescent layer 34.

[0037] Referring to FIG. 3F, the common electrode 37 and 38 is formed on the entire surface of the electron injection layer 36 and the counter common electrode 29. Since the common electrode is electrically connected to the counter common electrode 29, the electric current flowing through the common electrode is flown out through the counter common electrode 29, which has a smaller resistance, thereby resolving the resistance-related problem of the common electrode. The common electrode includes the metal common electrode 37 and the transparent common electrode 38. In order to form the metal common electrode 37, an aluminum (Al) layer having the thickness of several nanometers (nm) is deposited on the entire surface of the electron injection layer 36 and the counter common electrode 29, which is then etched to have a thickness equal to or less than 5 nanometers (nm). Alternatively, a layer of a Mg_xAg_{x-1} metal group having a thickness equal to or less than 5 nanometers (nm) can be deposited instead of the aluminum layer. On the other hand, another method for forming the metal common electrode 37 is to serially deposit a lithium fluoride (LiF) layer having a thickness of about 0.5 nanometers (nm) and an aluminum (Al) layer of about 1

nanometer (nm). In addition, the transparent common electrode 38 is formed of a transparent conductive material, such as indium tin oxide (ITO) or indium zinc oxide (IZO).

[0038] The metal common electrode 37 may be omitted, and the transparent common electrode 38 may be formed to be electrically connected to the counter common electrode 29, instead of the metal common electrode 37.

[0039] Thereafter, as shown in FIG. 3G, a protective layer 39 is formed to protect the organic electroluminescent layer 34, the electron transport layer 35, and the electron injection layer 36 from oxygen or moisture. Also, although not shown in the drawings, a protective cap is mounted on the protective layer 39 by using a sealant and a transparent substrate, thereby completing the top-emission active matrix electroluminescence device according to the present invention.

20 Second Embodiment

[0040] FIGs. 5A to 5F illustrate the process steps of a method for fabricating the active matrix electroluminescence device according to a second embodiment which does not form part of the present invention. Referring to FIG. 5A, the semiconductor layer 122 is formed on the glass substrate 121 in order to be used as an active layer of the thin film transistor B. The semiconductor layer 122 is made of poly-silicon. Subsequently, the semiconductor layer 122 is patterned to leave only a portion of the semiconductor layer 122, corresponding to the area on which the thin film transistor B is to be formed. Then, the gate insulating layer 123 is deposited on the entire surface of the glass substrate 121 and the semiconductor layer 122, and a conductive material layer is deposited on the gate insulating layer 123, so as to form the gate electrode. The conductive material layer is patterned so that only a predetermined portion remains on the patterned semiconductor layer 122, thereby forming the gate electrode 24.

[0041] The gate electrode 24 is used as a mask for injecting impurities, such as boron (B) or potassium (P), and the semiconductor layer 122, which is then processed with heat-treatment in order to the source and drain areas 122a and 122b of the thin film transistor B. The area of the semiconductor layer 122 having no impurities injected therein becomes the channel area 122c. Herein, since the impurities are injected by using the gate electrode 124 as the mask, the boundaries of the source and drain areas 122a and 122b and the boundary of the channel area 122c are aligned with both edges of the gate electrode 124.

[0042] The interlayer dielectric 125 is formed on the gate insulating layer 123 and the gate electrode 124. Then, the interlayer dielectric 125 and the gate insulating layer 123 are selectively etched, so as to expose a portion of the upper surface of the source and drain areas 122a and 122b, thereby forming the contact holes. And, the

contact holes are filled with metal, so as to form the electrode lines 126 each electrically contacting the source and drain areas 122a and 122b.

[0043] Subsequently, an insulating material is deposited on the interlayer dielectric 125 and the electrode lines 126 by using a spin-coating method, thereby depositing the planarization insulating layer 127. The planarization insulating layer 127 is then hardened through a pre-baking process. Furthermore, the planarization insulating layer 127 is selectively removed to expose the electrode line 126 connected to the drain area 122b of the thin film transistor B, thereby forming the via hole.

[0044] A metallic material layer is deposited on the entire surface of the via hole and the planarization insulating layer 127. In the bottom-emission ELD, the metallic material layer is formed of a transparent material, such as indium-tin-oxide (ITO). Conversely, in the top-emission ELD, the metallic material layer is formed of a metal having high reflectivity and work function. More specifically, in this case, the metallic material layer is formed of one of or an alloy of chrome (Cr), aluminum (Al), molybdenum (Mo), and silver (Ag)-gold (Au) alloy, and a multi-layer can be formed by using such metals. The metallic material layer deposited on the inner layer of the via hole of the planarization insulating layer 127, is connected to the electrode line 126 formed at the bottom of the via hole.

[0045] The metallic material layer is selectively removed so as to form a pixel electrode 128 in each pixel area. And, simultaneously, the counter common electrode 129 is formed in the area outside of the pixel area. The counter common electrode 129 is formed between and spaced apart from the pixel electrodes 128 at a predetermined distance. In other words, the counter common electrode 129 is formed at the boundary area between each pixel electrode on the planarization insulating layer 127. The counter common electrode 129 is formed in a stripe form over the thin film transistor B and parallel to the gate electrode 124 of the thin film transistor B.

[0046] Referring to FIG. 5B, after depositing an insulating material on the entire surface of the planarization insulating layer 127, the pixel electrodes 128, the counter common electrode 129, the insulating material layer is selectively removed, so as to form the insulating layer 130 on an area excluding the pixel area, more specifically, on the boundary area between the pixel areas. At this point, the insulating layer 130 is also not formed on a portion of the surface of the counter common electrode 129. In other words, the insulating layer 130 formed between the pixel electrode 128 and the counter common electrode 129 overlaps only a portion of each of the pixel electrode 128 and the counter common electrode 129. In order to expose a portion of the surface of the counter common electrode 129, the insulating layer 130 includes a trench formed on the counter common electrode 129 in the same direction as the length the counter common electrode 129.

[0047] Subsequently, an emission layer is formed on the pixel electrode 128. Herein, the emission layer is

formed of the hole injection layer 132, the hole transport layer 133, the organic electroluminescent layer 134, the electron transport layer 135, and the electron injection layer 136 serially deposited thereon. Referring to FIG. 5C, the shadow mask 131 is used to serially deposit the hole injection layer 132, the hole transport layer 133, the organic electroluminescent layer 134, the electron transport layer 135, and the electron injection layer 136 on the pixel electrode 128 and a portion of the insulating layer 130. The organic electroluminescent layer 134 includes red (R), green (G), and blue (B) organic electroluminescent layers 134, 134', and 134" depending upon the emitted color. Referring to FIG. 5d, the R, G, and B organic electroluminescent layers 134, 134', and 134" are serially formed on each of the corresponding pixel areas using the shadow mask 131. Herein, the hole injection layer 132, the hole transport layer 133, the organic electroluminescent layer 134, the electron transport layer 135, and the organic electroluminescent layer 134 are deposited only in the pixel area.

[0048] Referring to FIG. 3E, common electrode 137 and 138 is formed on the entire surface of the electron injection layer 136, a portion of the insulating layer 130, and the counter common electrode 129. Since the common electrode is electrically connected to the counter common electrode 129, the electric current flowing through the common electrode is flown out through the counter common electrode 129, which has a smaller resistance, thereby resolving the resistance-related problem of the common electrode. The common electrode includes the metal common electrode 137 and the transparent common electrode 138. In order to form the metal common electrode 137, an aluminum (Al) layer having the thickness of several nanometers (nm) is deposited on the entire surface of the electron injection layer 136, the portion of the insulating layer 130, and the counter common electrode 129. A silver layer or a layer of a Mg_xAg_{x-1} metal group having a thickness equal to or less than 5 nanometers (nm) is deposited on the aluminum layer. Another method for forming the metal common electrode 137 is to serially deposit a lithium fluoride (LiF) layer having a thickness of about 0.5 nanometers (nm) and an aluminum (Al) layer of about 1 nanometer (nm). In addition, the transparent common electrode 138 is formed of a transparent conductive material, such as indium tin oxide (ITO) or indium zinc oxide (IZO).

[0049] Thereafter, as shown in FIG. 3F, a protective layer 139 is formed to protect the organic electroluminescent layer 134, the electron transport layer 135, and the electron injection layer 136 from oxygen or moisture. Also, although not shown in the drawings, a protective cap is mounted on the protective layer 139 by using a sealant and a transparent substrate, thereby completing the top-emission active matrix electroluminescence device.

[0050] As described above, in the top-emission active matrix electroluminescence device according to the present invention, since a counter common electrode is formed to be electrically connected to a common elec-

trode, the electric current flow can be facilitated even though the metal common electrode is formed to be thin. Moreover, due to the thinness of the metal common electrode, the light transmissivity can be enhanced. Thus, a top-emission active matrix electroluminescence device having an improved durability and an enhanced reliability can be provided.

[0051] It will be apparent to those skilled in the art that various modifications and variations can be made in the present invention without departing from the scope of the invention, which is defined in the appended claims. Thus, it is intended that the present invention covers the modifications and variations of this invention provided they come within the scope of the appended claims.

Claims

1. An active matrix electroluminescence device, comprising:

a substrate (21) including a thin film transistor (13) and a pixel area defined thereon;

a first insulating layer (27) on the substrate (21) and the thin film transistor (13);

a first electrode (28) on the first insulating layer (27) of the pixel area and connected to the thin film transistor (13) through a contact hole within the first insulating layer (27);

a second electrode in a stripe form (29) on the first insulating layer (27) provided between rows of first electrodes (28), wherein the second electrode (29) is the same layer as the first electrode (28) on the first insulating layer (27) and overlaps the thin film transistor (13), not overlapping the pixel area;

a second insulating layer (30) on a predetermined area on the first electrode (28) and the second electrode (29), wherein the second insulating layer (30) includes a trench along the direction of the second electrode (29);

an emission layer (32,33,34,35,36) on the first electrode (28);

a third electrode (37,38) on the emission layer and electrically connected to the second electrode (29) through the trench;

a protective layer (39) on the third electrode (38) and having a flat surface; and

a protective cap on the protective layer (39) using a sealant and a substrate,

wherein:

the emission layer includes a hole injection layer (32), a hole transport layer (33), an organic electroluminescent layer (34), an electron transport layer (35), and an electron injection layer (36) serially deposited on one another,

the hole injection layer (32), the hole transport layer (33), the electron transport layer (35) and the electron injection layer (36) have a stripe form between adjacent second electrodes (29),

the organic electroluminescent layer (34) is independently positioned in the pixel area different from the stripe form, and the hole transport layer (33) directly contacts with the electron transport layer (35) on the second insulating layer (30).

2. The device according to claim 1, wherein the first electrode is on the pixel area, and the second electrode is between each pixel area.

3. The device according to claim 1, wherein the emission layer does not overlap the second electrode.

4. The device according to claim 1, wherein the third electrode includes a transparent electrode deposited on a metal electrode.

5. The device according to claim 1, wherein the third electrode is a transparent electrode.

6. A method for fabricating an active matrix electroluminescence device, comprising:

forming a thin film transistor on a substrate having a pixel area defined thereon;

forming a first insulating layer having a contact hole on the thin film transistor and the substrate;

forming simultaneously a first electrode on the first insulating layer of the pixel area and a second electrode in a stripe form on the first insulating layer between rows of first electrodes (28), wherein the first electrode is connected to the thin film transistor through the contact hole and the second electrode overlaps the thin film transistor, not overlapping the pixel area;

forming a second insulating layer on a predetermined area on the first electrode and the second electrode, wherein the second insulating layer includes a trench exposing the second electrode;

forming an emission layer on the first electrode;

forming a third electrode on the emission layer, the third electrode being electrically connected to the second electrode through the trench;

forming a protective layer on the third electrode, the protective layer having a flat surface; and

forming protective cap on the protective layer by using a sealant and a substrate,

wherein the forming the emission layer comprises:

depositing serially a hole injection layer and

- a hole transport layer on the first electrode using a first shadow mask, the first shadow mask having an opening area of a stripe form between adjacent stripes, aligning the second electrode; 5
- depositing an organic electroluminescent layer on the hole transport layer using a second shadow mask; and
- depositing serially an electron transport layer and an electron injection layer on the organic electroluminescent layer using the first shadow mask, 10
- wherein
- the hole injection layer, the hole transport layer, the electron transport layer and the electron injection layer are formed in the stripe form between adjacent second electrodes, 15
- the organic electroluminescent layer is independently formed in the pixel area different from the stripe form, and 20
- the hole transport layer directly contacts with the electron transport layer on the second insulating layer. 25
7. The method according to claim 6, wherein the first electrode is formed in the pixel area on the insulating layer, and simultaneously, the second electrode is formed between the each pixel area. 30
8. The method according to claim 6, wherein the first electrode and the second electrode are formed of the same reflective material. 35
9. The method according to claim 6, wherein the third electrode is formed of a transparent electrode deposited on a metal electrode. 40
10. The method according to claim 9, wherein the metal electrode is formed to have a thickness equal to or less than 5 nanometers (nm). 45
11. The method according to claim 6, wherein the emission layer is not formed on the second electrode.

Patentansprüche

1. Aktive Matricelektrolumineszenzvorrichtung, die Folgendes umfasst: 50
- ein Substrat (21), das einen Dünnschichttransistor (13) und einen darauf definierten Pixelbereich enthält;
- eine erste Isolierschicht (27) auf dem Substrat (21) und dem Dünnschichttransistor (13); 55
- eine erste Elektrode (28) auf der ersten Isolierschicht (27) des Pixelbereichs, die mit dem

Dünnschichttransistor (13) durch ein Kontaktloch innerhalb der ersten Isolierschicht (27) verbunden ist;

eine zweite Elektrode in einer Streifenform (29) auf der ersten Isolierschicht (27), die zwischen Reihen erster Elektroden (28) vorgesehen ist, wobei die zweite Elektrode (29) dieselbe Schicht wie die erste Elektrode (28) auf der ersten Isolierschicht (27) ist und den Dünnschichttransistor (13) überdeckt, wobei sie den Pixelbereich nicht überdeckt;

eine zweite Isolierschicht (30) auf einem vorgegebenen Bereich auf der ersten Elektrode (28) und der zweiten Elektrode (29), wobei die zweite Isolierschicht (30) eine Rille entlang der Richtung der zweiten Elektrode (29) enthält;

eine Emissionsschicht (32, 33, 34, 35, 36) auf der ersten Elektrode (28);

eine dritte Elektrode (37, 38) auf der Emissionsschicht, die mit der zweiten Elektrode (29) durch die Rille elektrisch verbunden ist;

eine Schutzschicht (39) auf der dritten Elektrode (38), die eine flache Oberfläche besitzt; und

eine Schutzkappe auf der Schutzschicht (39), die ein Dichtungsmittel und ein Substrat verwendet, wobei:

die Emissionsschicht eine Lochinjektionsschicht (32), eine Lochtransportschicht (33), eine organische Elektrolumineszenzschicht (34), eine Elektronentransportschicht (35) und eine Elektroneninjectionsschicht (36), die nacheinander aufeinander aufgebracht sind, enthält,

die Lochinjektionsschicht (32), die Lochtransportschicht (33), die Elektronentransportschicht (35) und die Elektroneninjectionsschicht (36) eine Streifenform zwischen benachbarten zweiten Elektroden (29) besitzen,

die organische Elektrolumineszenzschicht (34) unabhängig in dem Pixelbereich, der von der Streifenform verschieden ist, positioniert ist und

die Lochtransportschicht (33) unmittelbar die Elektronentransportschicht (35) auf der zweiten Isolierschicht (30) kontaktiert.

2. Vorrichtung nach Anspruch 1, wobei die erste Elektrode auf dem Pixelbereich liegt und die zweite Elektrode zwischen jedem Pixelbereich liegt.
3. Vorrichtung nach Anspruch 1, wobei die Emissionsschicht die zweite Elektrode nicht überdeckt.
4. Vorrichtung nach Anspruch 1, wobei die dritte Elektrode eine transparente Elektrode enthält, die auf eine Metallelektrode aufgebracht ist.

5. Vorrichtung nach Anspruch 1, wobei die dritte Elektrode eine transparente Elektrode ist.

6. Verfahren zum Herstellen einer aktiven Matrixelektrolumineszenzvorrichtung, die Folgendes umfasst:

Bilden eines Dünnschichttransistors auf einem Substrat mit einem darauf definierten Pixelbereich;

Bilden einer ersten Isolierschicht mit einem Kontaktloch auf dem Dünnschichttransistor und dem Substrat;

gleichzeitig Bilden einer ersten Elektrode auf der ersten Isolierschicht des Pixelbereichs und einer zweiten Elektrode in einer Streifenform auf der ersten Isolierschicht zwischen Reihen erster Elektroden (28), wobei die erste Elektrode mit dem Dünnschichttransistor durch das Kontaktloch verbunden ist und die zweite Elektrode den Dünnschichttransistor überdeckt, wobei sie den Pixelbereich nicht überdeckt;

Bilden einer zweiten Isolierschicht auf einem vorgegebenen Bereich auf der ersten Elektrode und der zweiten Elektrode, wobei die zweite Isolierschicht eine Rille enthält, die die zweite Elektrode freilegt;

Bilden einer Emissionsschicht auf der ersten Elektrode;

Bilden einer dritten Elektrode auf der Emissionsschicht, wobei die dritte Elektrode mit der zweiten Elektrode durch die Rille elektrisch verbunden ist;

Bilden einer Schutzschicht auf der dritten Elektrode, wobei die Schutzschicht eine flache Oberfläche besitzt; und

Bilden einer Schutzkappe auf der Schutzschicht durch Verwenden eines Dichtungsmittels und eines Substrats,

wobei das Bilden der Emissionsschicht umfasst:

nacheinander Aufbringen einer Lochinjektionsschicht und einer Lochtransportschicht auf der ersten Elektrode unter Verwendung einer ersten Schattenmaske, wobei die erste Schattenmaske einen Öffnungsbereich einer Streifenform zwischen benachbarten Streifen besitzt, der die zweite Elektrode ausrichtet;

Aufbringen einer organischen Elektrolumineszenzschicht auf die Lochtransportschicht unter Verwendung einer zweiten Schattenmaske; und

nacheinander Aufbringen einer Elektronentransportschicht und einer Elektroneninjectionsschicht auf der organischen Elektrolumineszenzschicht unter Verwendung der ersten Schattenmaske, wobei

die Lochinjektionsschicht, die Lochtransportschicht, die Elektronentransportschicht und die Elektroneninjectionsschicht in der Streifenform zwischen benachbarten zweiten Elektroden gebildet werden, die organische Elektrolumineszenzschicht unabhängig in dem Pixelbereich, der von der Streifenform verschieden ist, gebildet wird und

die Lochtransportschicht die Elektronentransportschicht auf der zweiten Isolierschicht unmittelbar kontaktiert.

7. Verfahren nach Anspruch 6, wobei die erste Elektrode in dem Pixelbereich auf der Isolierschicht gebildet wird und gleichzeitig die zweite Elektrode zwischen jedem Pixelbereich gebildet wird.

8. Verfahren nach Anspruch 6, wobei die erste Elektrode und die zweite Elektrode auf demselben reflektierenden Material gebildet werden.

9. Verfahren nach Anspruch 6, wobei die dritte Elektrode aus einer transparenten Elektrode, die auf eine Metallelektrode aufgebracht ist, gebildet wird.

10. Verfahren nach Anspruch 9, wobei die Metallelektrode so gebildet wird, dass sie eine Dicke besitzt, die gleich oder kleiner als 5 Nanometer (nm) ist.

11. Verfahren nach Anspruch 6, wobei die Emissionsschicht nicht auf der zweiten Elektrode gebildet wird.

40 Revendications

1. Dispositif électroluminescent à matrice active, comprenant :

45 un substrat (21) comprenant un transistor à film mince (13) et une zone de pixels définie sur celui-ci ;

une première couche isolante (27) sur le substrat (21) et le transistor à film mince (13) ;

50 une première électrode (28) sur la première couche isolante (27) de la zone de pixels et reliée au transistor à film mince (13) par l'intermédiaire d'un trou de contact à l'intérieur de la première couche isolante (27) ;

55 une deuxième électrode en forme de bande (29) sur la première couche isolante (27) prévue entre des rangées de premières électrodes (28), dans lequel la deuxième électrode (29) est la

même couche que la première électrode (28) sur la première couche isolante (27) et chevauche le transistor à film mince (13), sans chevaucher la zone de pixels ;

une deuxième couche isolante (30) dans une zone prédéterminée de la première électrode (28) et de la deuxième électrode (29), dans lequel la deuxième couche isolante (30) comprend une tranchée dans le sens de la deuxième électrode (29) ;

une couche d'émission (32, 33, 34, 35, 36) sur la première électrode (28) ;

une troisième électrode (37, 38) sur la couche d'émission et reliée électriquement à la deuxième électrode (29) par l'intermédiaire de la tranchée ;

une couche protectrice (39) sur la troisième électrode (38) et comportant une surface plate ; et

une calotte protectrice sur la couche protectrice (39) utilisant un scellant et un substrat, dans lequel :

la couche d'émission comprend une couche d'injection de trous (32), une couche de transport de trous (33), une couche électroluminescente organique (34), une couche de transport d'électrons (35), et une couche d'injection d'électrons (36) disposées en série l'une sur l'autre,

la couche d'injection de trous (32), la couche de transport de trous (33), la couche de transport d'électrons (35) et la couche d'injection d'électrons (36) sont en forme de bande entre des deuxième électrodes (29) adjacentes,

la couche électroluminescente organique (34) est positionnée indépendamment dans la zone de pixels différente de la forme de bande, et

la couche de transport de trous (33) est en contact directement avec la couche de transport d'électrons (35) sur la deuxième couche isolante (30).

2. Dispositif selon la revendication 1, dans lequel la première électrode est dans la zone de pixels, et la deuxième électrode est entre chaque zone de pixels.

3. Dispositif selon la revendication 1, dans lequel la couche d'émission ne chevauche pas la deuxième électrode.

4. Dispositif selon la revendication 1, dans lequel la troisième électrode comprend une électrode transparente déposée sur une électrode métallique.

5. Dispositif selon la revendication 1, dans lequel la troi-

sième électrode est une électrode transparente.

6. Procédé de fabrication d'un dispositif électroluminescent à matrice active, comprenant :

la formation d'un transistor à film mince sur un substrat comportant une zone de pixels définie sur celui-ci ;

la formation d'une première couche isolante comportant un trou de contact sur le transistor à film mince et le substrat ;

la formation simultanément d'une première électrode sur la première couche isolante de la zone de pixels et d'une deuxième électrode en forme de bande sur la première couche isolante entre des rangées de premières électrodes (28), dans lequel la première électrode est reliée au transistor à film mince par l'intermédiaire du trou de contact et la deuxième électrode chevauche le transistor à film mince, sans chevaucher la zone de pixels ;

la formation d'une deuxième couche isolante dans une zone prédéterminée de la première électrode et de la deuxième électrode, dans lequel la deuxième couche isolante comprend une tranchée exposant la deuxième électrode ;

la formation d'une couche d'émission sur la première électrode ;

la formation d'une troisième électrode sur la couche d'émission, la troisième électrode étant reliée électriquement à la deuxième électrode par l'intermédiaire de la tranchée ;

la formation d'une couche protectrice sur la troisième électrode, la couche protectrice comportant une surface plate ; et

la formation d'une calotte protectrice sur la couche protectrice en utilisant un scellant et un substrat, dans lequel la formation de la couche d'émission comprend :

le dépôt en série d'une couche d'injection de trous et d'une couche de transport de trous sur la première électrode en utilisant un premier masque d'ombre, le premier masque d'ombre comprenant une zone d'ouverture d'une forme de bande entre des bandes adjacentes, en alignant la deuxième électrode ;

le dépôt d'une couche électroluminescente organique sur la couche de transport de trous en utilisant un deuxième masque d'ombre ; et

le dépôt en série d'une couche de transport d'électrons et d'une couche d'injection d'électrons sur la couche électroluminescente organique un utilisant le premier masque d'ombre,

- dans lequel
la couche d'injection de trous, la couche de transport de trous, la couche de transport d'électrons et la couche d'injection d'électrons sont en forme de bande entre des deuxièmes électrodes adjacentes, 5
la couche électroluminescente organique est formée indépendamment dans la zone de pixels différente de la forme de bande, et 10
la couche de transport de trous est en contact directement avec la couche de transport d'électrons sur la deuxième couche isolante.
7. Procédé selon la revendication 6, dans lequel la première électrode est formée dans la zone de pixels sur la couche isolante, et simultanément la deuxième électrode est formée entre chaque zone de pixels. 15
8. Procédé selon la revendication 6, dans lequel la première électrode et la deuxième électrode sont constituées du même matériau réfléchissant. 20
9. Procédé selon la revendication 6, dans lequel la troisième électrode est formée d'une électrode transparente déposée sur une électrode métallique. 25
10. Procédé selon la revendication 9, dans lequel l'électrode métallique est formée pour avoir une épaisseur inférieure ou égale à 5 nanomètres (nm). 30
11. Procédé selon la revendication 6, dans lequel la couche d'émission n'est pas formée sur la deuxième électrode. 35

40

45

50

55

FIG.1

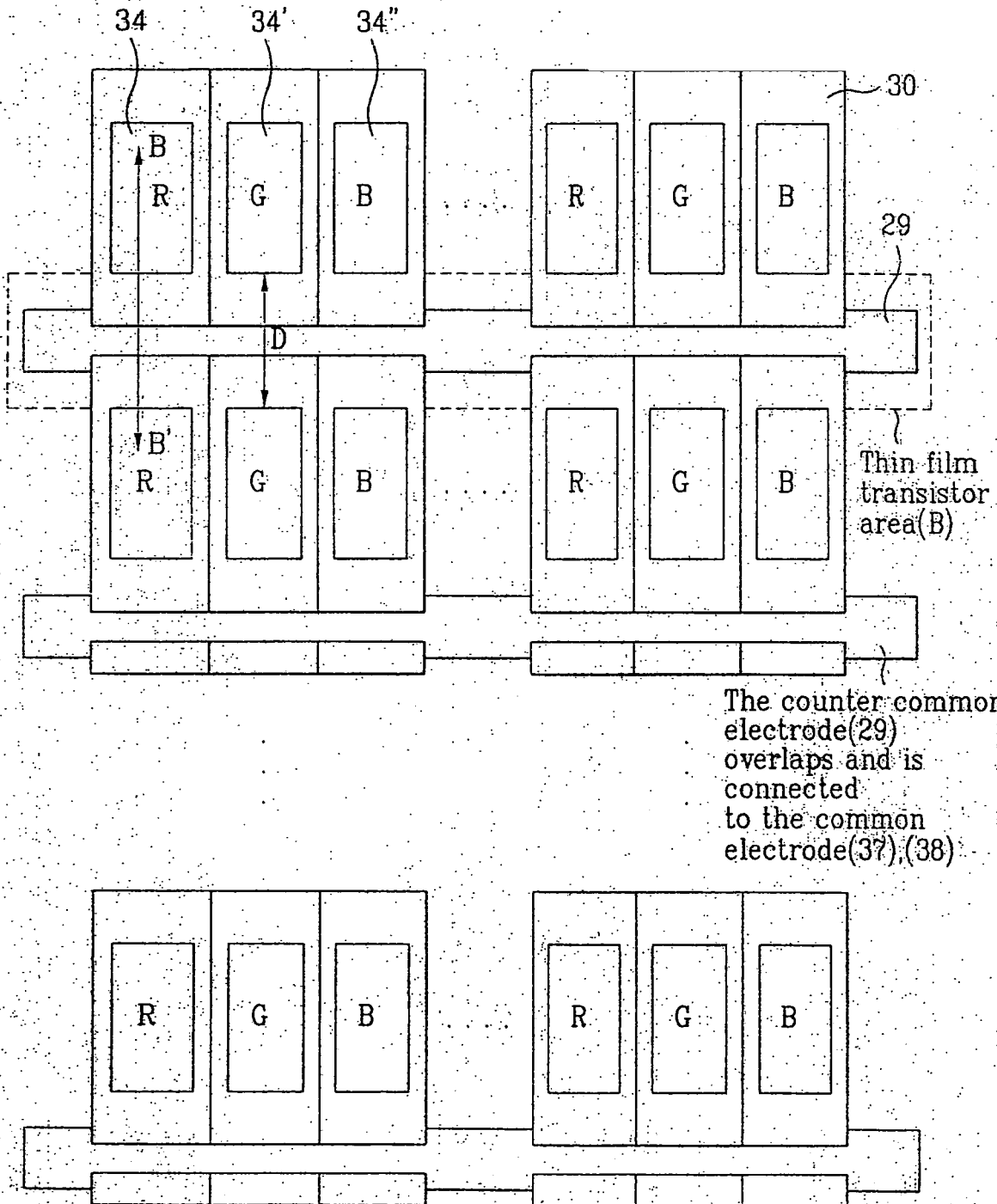

The counter common electrode (29) overlaps and is connected to the common electrode (37), (38)

FIG. 2

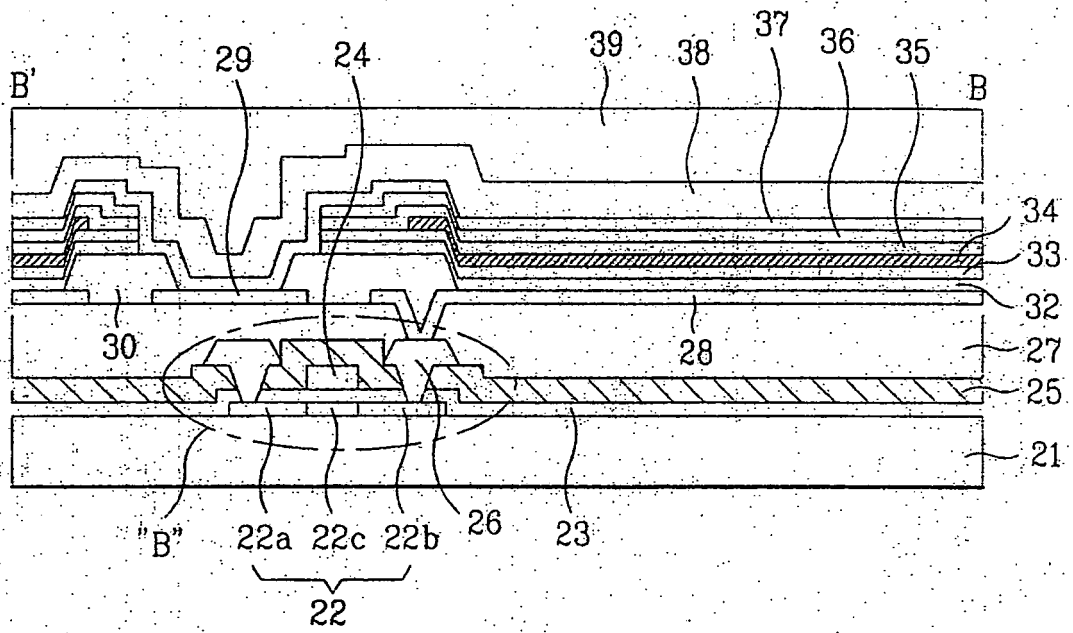

FIG. 3A

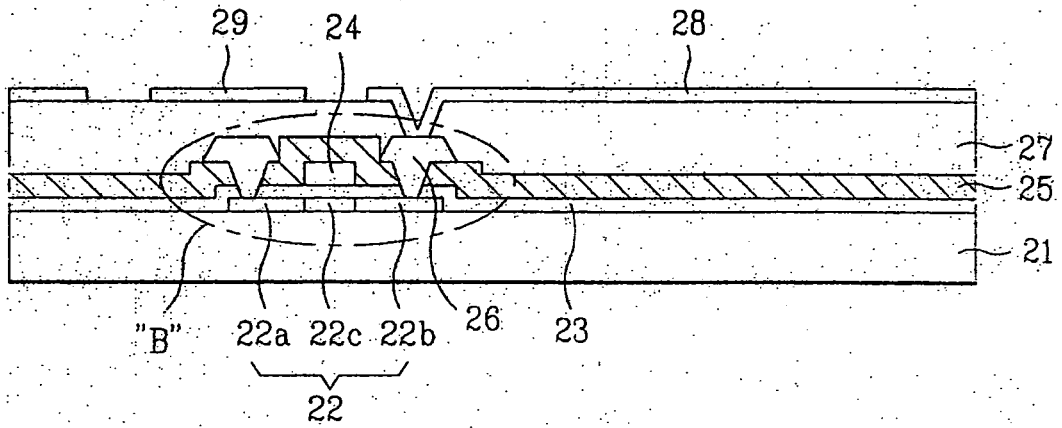

FIG. 3B

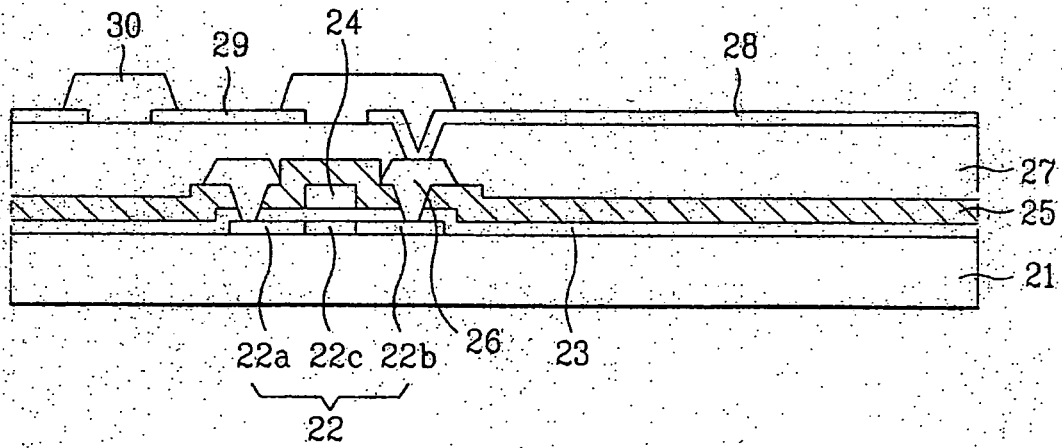

FIG. 3C

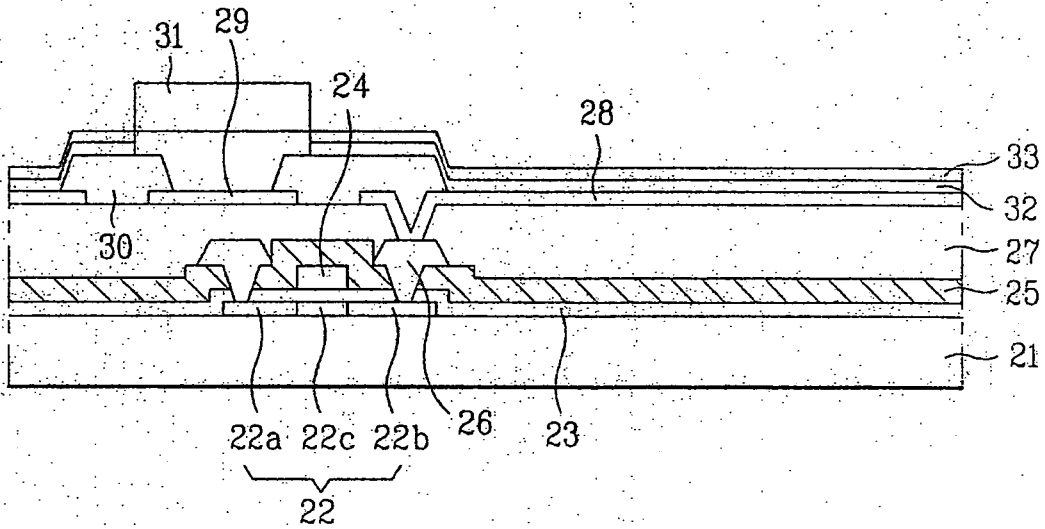

FIG. 3D

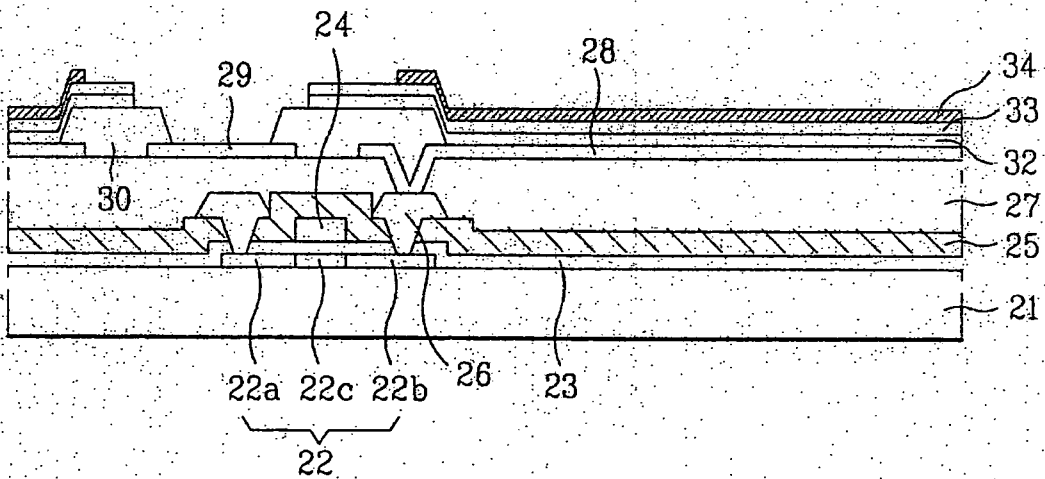

FIG. 4

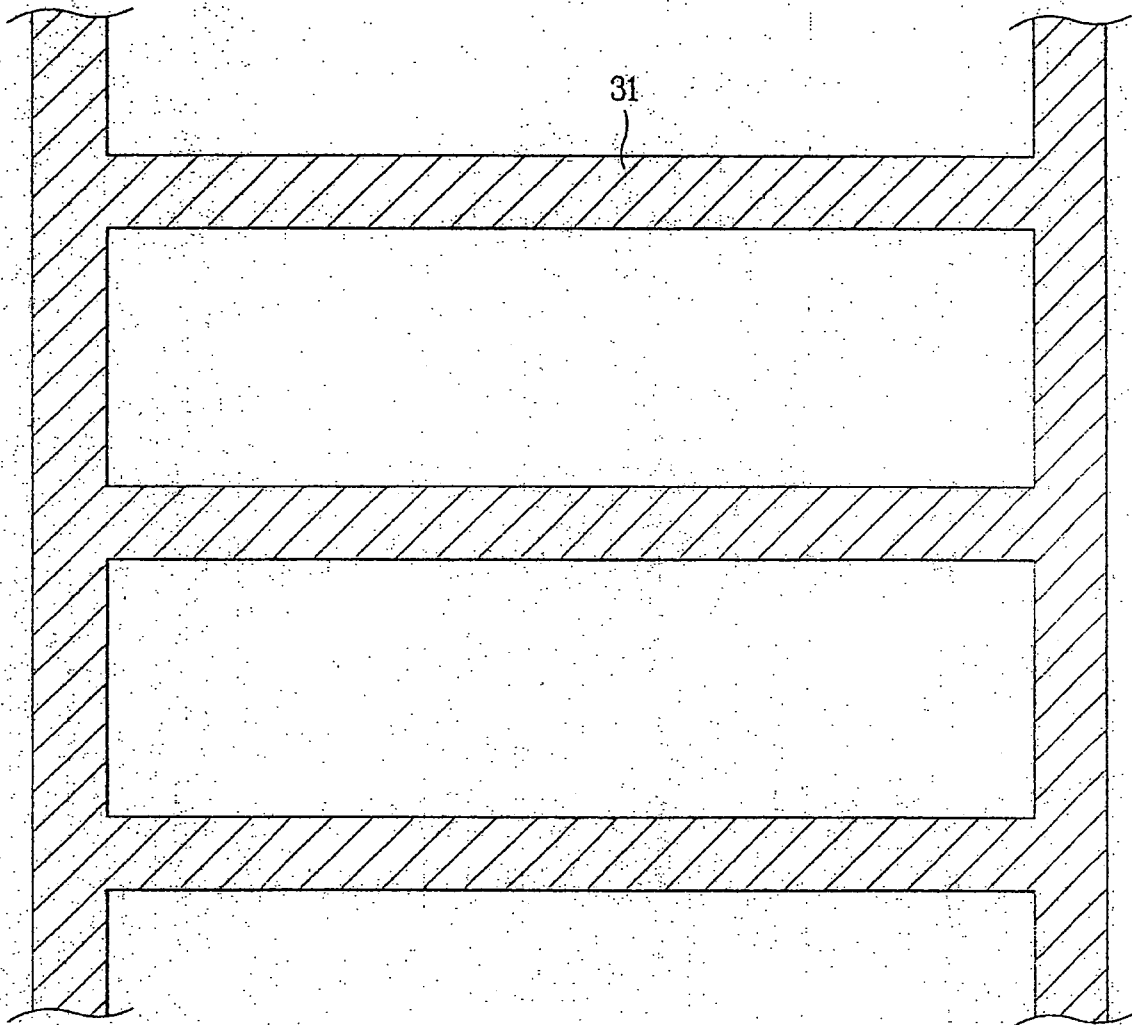

FIG. 5A

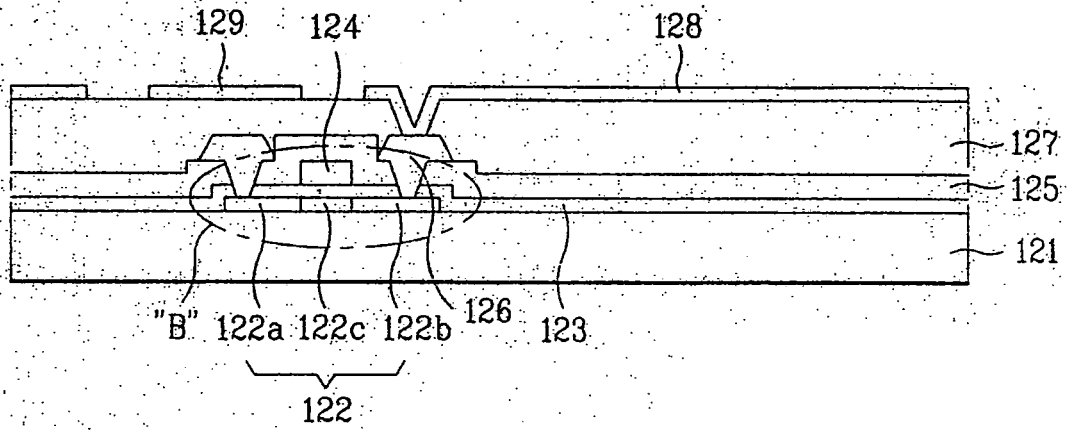

FIG. 5B

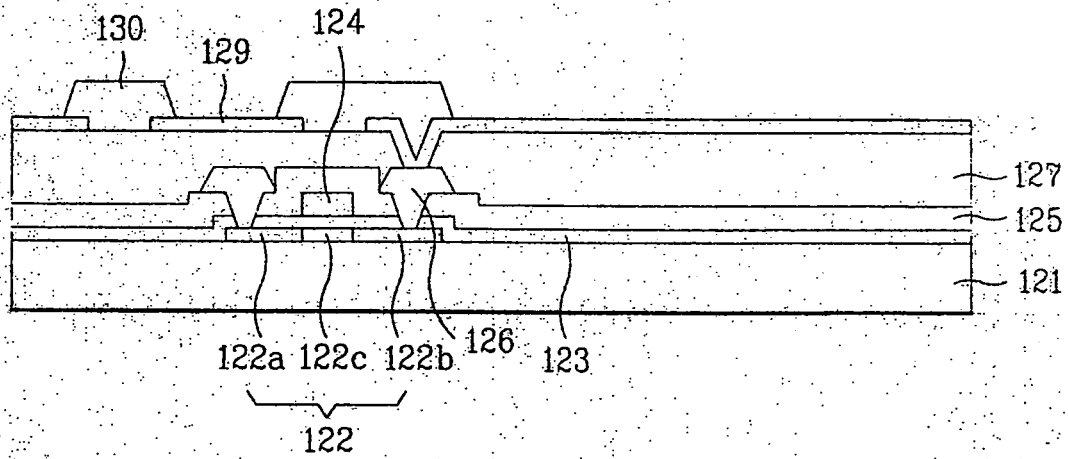

FIG. 5C

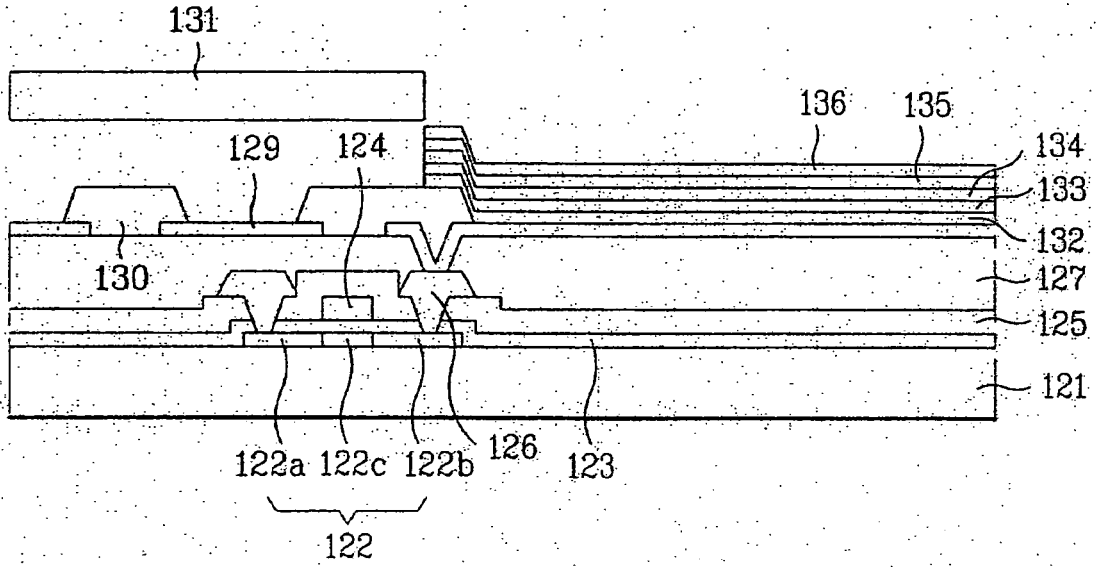

FIG. 5D

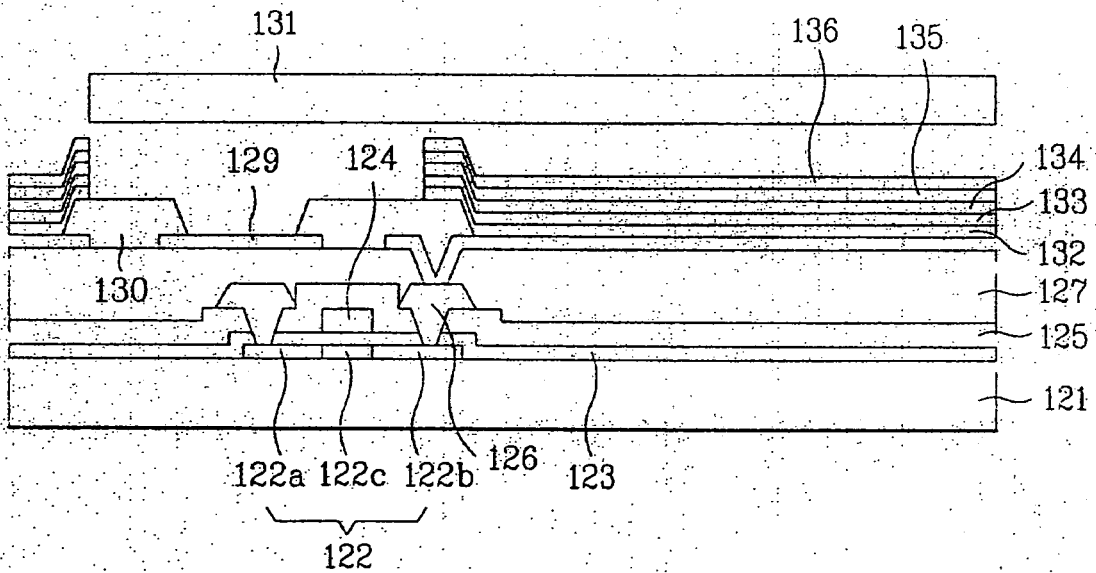

FIG. 5E

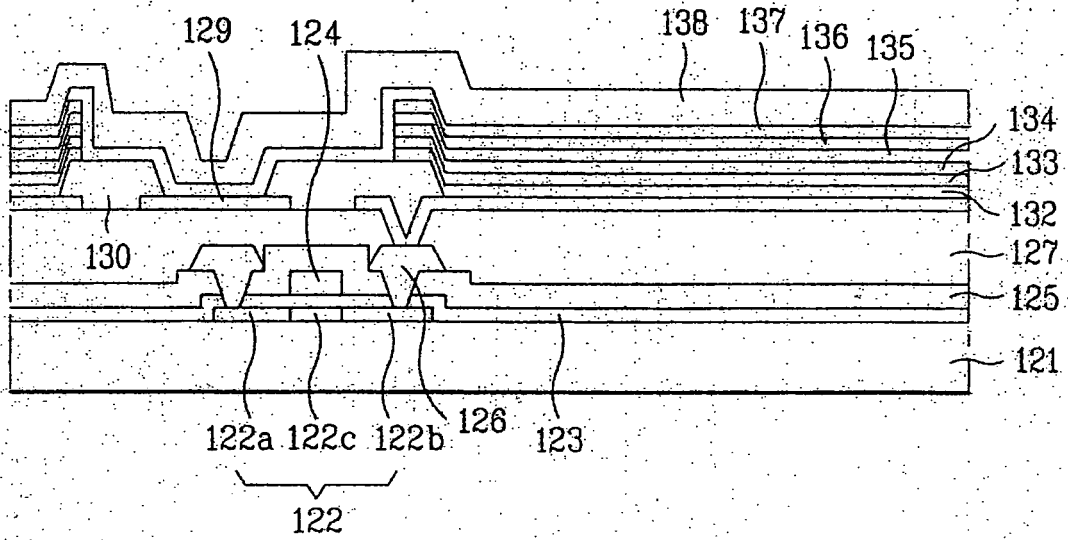
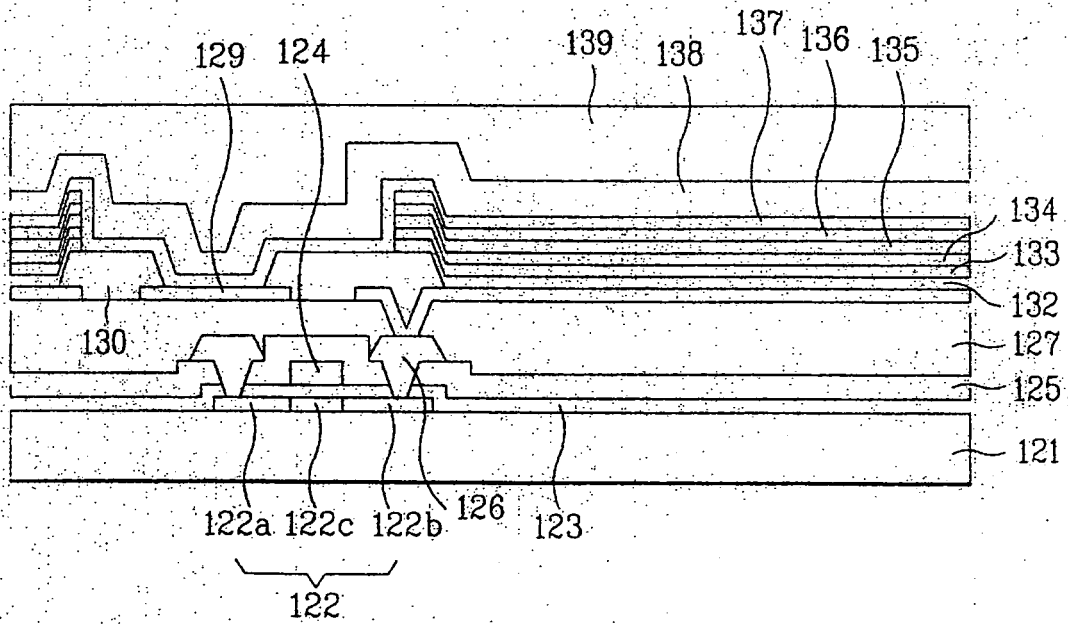

FIG. 5F



REFERENCES CITED IN THE DESCRIPTION

This list of references cited by the applicant is for the reader's convenience only. It does not form part of the European patent document. Even though great care has been taken in compiling the references, errors or omissions cannot be excluded and the EPO disclaims all liability in this regard.

Patent documents cited in the description

- US 20020158835 A1 [0006]
- EP 1122800 A2 [0007]
- EP 1274130 A2 [0008]
- EP 1160891 A2 [0009]

专利名称(译)	顶部发射有源矩阵有机电致发光显示装置及其制造方法		
公开(公告)号	EP1505666B1	公开(公告)日	2018-04-04
申请号	EP2004018107	申请日	2004-07-30
申请(专利权)人(译)	LG电子株式会社.		
当前申请(专利权)人(译)	LG DISPLAY CO. , LTD.		
[标]发明人	KIM HONG GYU		
发明人	KIM, HONG GYU		
IPC分类号	H01L27/32 H01L51/52 H05B33/26 G09F9/30 H01L27/15 H01L51/50 H05B33/00 H05B33/10 H05B33/12 H05B33/14 H05B33/20 H05B33/24		
CPC分类号	H01L27/3211 H01L27/3244 H01L27/3279 H01L51/5228 H01L51/5234 H01L2227/323 H01L2251/5315		
优先权	1020030054149 2003-08-05 KR 1020030054150 2003-08-05 KR		
其他公开文献	EP1505666A3 EP1505666A2		
外部链接	Espacenet		

摘要(译)

本发明公开了一种顶部发光有源矩阵电致发光器件及其制造方法，其中，当形成像素电极时，在像素区域外的区域中形成反公共电极，以同时提高发光效率和设备的电气功能。这里，即使公共电极形成成为薄层，对公共电极也电连接到公共电极，从而防止公共电极的过载和短路。

