

(19)



(11)

EP 1 170 719 B1

(12)

EUROPEAN PATENT SPECIFICATION

(45) Date of publication and mention of the grant of the patent:
14.09.2011 Bulletin 2011/37

(51) Int Cl.:
G09G 3/32^(2006.01)

(21) Application number: **01305904.3**

(22) Date of filing: **09.07.2001**

(54) **Current driven electrooptical device, e.g. organic electroluminescent display, with complementary driving transistors to counteract threshold voltage variations**

Stromgesteuerte elektrooptische Vorrichtung, z.B. elektrolumineszente Anzeige, mit komplementären Steuertransistoren, die gegen Änderungen der Schwellspannung wirksam sind

Dispositif électrooptique piloté par le courant, par exemple affichage électroluminescent, avec transistors de commande complémentaires, agissant contre les variations de la tension de seuil

(84) Designated Contracting States:
AT BE CH CY DE DK ES FI FR GB GR IE IT LI LU MC NL PT SE TR

(30) Priority: **07.07.2000 GB 0016815**

(43) Date of publication of application:
09.01.2002 Bulletin 2002/02

(73) Proprietor: **Seiko Epson Corporation Shinjuku-ku Tokyo (JP)**

(72) Inventor: **Tam, Simon Cambridge CB2 1SJ (GB)**

(74) Representative: **Sturt, Clifford Mark et al Miller Sturt Kenyon 9 John Street London WC1N 2ES (GB)**

(56) References cited:
**EP-A- 0 597 226 EP-A- 0 766 221
WO-A-01/26087 WO-A-99/65011
JP-A- 9 306 685 US-A- 3 443 151
US-A- 4 712 021 US-A- 5 525 923
US-A- 6 011 532**

EP 1 170 719 B1

Note: Within nine months of the publication of the mention of the grant of the European patent in the European Patent Bulletin, any person may give notice to the European Patent Office of opposition to that patent, in accordance with the Implementing Regulations. Notice of opposition shall not be deemed to have been filed until the opposition fee has been paid. (Art. 99(1) European Patent Convention).

Description

[0001] The present invention relates to a driver circuit. One particular application of such a driver circuit is for driving an organic electroluminescent element.

[0002] An organic electroluminescent (OEL) element comprises a light emitting material layer sandwiched between an anode layer and a cathode layer. Electrically, this element operates like a diode. Optically, it emits light when forward biased and the intensity of the emission increases with the forward bias current. It is possible to construct a display panel with a matrix of OEL elements fabricated on a transparent substrate and with at least one of the electrode layers being transparent. It is also possible to integrate the driving circuit on the same panel by using low temperature polysilicon thin film transistor (TFT) technology.

[0003] In a basic analog driving scheme for an active matrix OEL display, a minimum of two transistors are required per pixel. Such a driving scheme is illustrated in Figure 1. Transistor T_1 is provided to address the pixel and transistor T_2 is provided to convert a data voltage signal V_{Data} into current which drives the OEL element at a designated brightness. The data signal is stored by a storage capacitor $C_{storage}$ when the pixel is not addressed. Although p-channel TFTs are shown in the figure, the same principle can also be applied for a circuit utilising n-channel TFTs.

[0004] There are problems associated with TFT analog circuits and OEL elements do not act like perfect diodes. The light emitting material does, however, have relatively uniform characteristics. Due to the nature of the TFT fabrication technique, spatial variation of the TFT characteristics exists over the extent of the display panel. One of the most important considerations in a TFT analog circuit is the variation of threshold voltage, ΔV_T , from device to device. The effect of such variation in an OEL display, exacerbated by the non perfect diode behaviour, is the non-uniform pixel brightness over the display area of the panel, which seriously affects the image quality. Therefore, a built-in circuit for compensating a dispersion of transistor characteristics is required.

[0005] A circuit shown in figure 2 is proposed as one of built-in for compensating a variation of transistor characteristics. In this circuit, transistor T_1 is provided for addressing the pixel. Transistor T_2 operates as an analog current control to provide the driving current to the OEL element. Transistor T_3 connects between the drain and gate of transistor T_2 and toggles transistor T_2 to act either as a diode or in a saturation mode. Transistor T_4 acts as a switch in response to an applied waveform V_{GP} . Either Transistor T_1 or transistor T_4 can be ON at any one time. Initially, at time t_0 shown in the timing diagram of Figure 2, transistors T_1 and T_3 are OFF, and transistor T_4 is ON. When transistor T_4 is OFF, transistors T_1 and T_3 are ON, and a current I_{DAT} of known value is allowed to flow into the OEL element, through transistor T_2 . This is the programming stage because the threshold voltage of tran-

sistor T_2 is measured with transistor T_3 turned ON which shorts the drain and gate of transistor T_2 . Hence transistor T_2 operates as a diode while the programming current is allowed to flow through transistors T_1 and T_2 and into the OEL element. The detected threshold voltage of transistor T_2 is stored by a capacitor C_1 connected between the gate and source terminals of transistor T_2 when transistors T_3 and T_1 are switched OFF. Transistor T_4 is then turned ON by driving waveform V_{GP} and the current through the OEL element is now provided by supply V_{DD} . If the slope of the output characteristics for transistor T_2 were flat, the reproduced current would be the same as the programmed current for any threshold voltage of T_2 detected and stored in capacitor C_1 . However, by turning ON transistor T_4 , the drain-source voltage of transistor T_2 is pulled up, so a flat output characteristic will maintain the reproduced current at the same level as the programmed current. Note that ΔV_{T2} shown in figure 2 is imaginary, not real. It has been used solely to represent the threshold voltage of transistor T_2 .

[0006] A constant current is provided, in theory, during a subsequent active programming stage, which is signified by the time interval t_2 to t_5 in the timing diagram shown in figure 2. The reproduction stage starts at time t_6 .

[0007] The circuit of Figure 2 does provide an improvement over the circuit shown in Figure 1 but variations in the threshold value of the control transistor are not fully compensated and variations in image brightness over the display area of the panel remain.

[0008] US-A-3443151 discloses an electrical control circuit including a pair of opposite-conductivity field effect transistors whose source-drain current paths are connected in series with a power supply and an EL element.

[0009] EP-A-0597226 discloses an LED display matrix where complementary MOS transistors are used for both row and column drivers, but does not consider variations of thresholds of the transistors. WO-A-9965011 discloses a pixel circuit for current driving an OLED, where an n-channel and a p-channel transistors are used, and a threshold compensation in a two stage process is carried out. In this circuit a single storage capacitor is used, to compensate the threshold variations of the n-channel transistor only.

[0010] The present invention seeks to provide, therefore, an improved compensated pixel driver circuit in which variations in the threshold voltages of the pixel driver transistor can be further compensated, thereby providing a more uniform pixel brightness over the display area of the panel and, therefore, improved image quality.

[0011] According to a first aspect of the present invention there is provided a driver circuit, comprising:

- a first storage capacitor;
- a second storage capacitor;
- an n-channel transistor, of which a gate is connected to the first storage capacitor;
- a p-channel transistor, of which a gate is connected

to the second storage capacitor; and
a current driven element disposed in a current path
between the n-channel transistor and the p-channel
transistor, wherein:

the driver circuit is arranged
to cause, during a programming stage, a data
current according to a data signal to flow through
the p-channel transistor and the n-channel trans-
istor so that a first operating voltage of the n-
channel transistor and a second operating volt-
age of the p-channel transistor are stored res-
pectively on the first storage capacitor and the
second storage capacitor, and
to cause, during a reproduction stage, the n-
channel transistor and the p-channel transistor
in combination to operatively control a driving
current supplied to the current driven element
depending on the first and second operating
voltages stored on the first and second storage
capacitors according to the data signal.

[0012] According to a second aspect of the present
invention there is also provided a driving method of a
driver circuit that is for a current driven element and that
has an n-channel transistor, a p-channel transistor, the
current driven element being disposed in a current path
between the n-channel transistor and the p-channel tran-
sistor, a first storage capacitor connected to a gate of the
n-channel transistor, and a second storage capacitor
connected to a gate of the p-channel transistor, compris-
ing:

a programming step of storing a first operating volt-
age of the n-channel transistor on the first storage
capacitor and a second operating voltage of the p-
channel transistor on the second storage capacitor
by supplying a data current according to a data signal
to the n-channel transistor and the p-channel tran-
sistor; and
a reproduction step of supplying a current to the cur-
rent driven element, said current being controlled by
the n-channel transistor and the p-channel transistor
in combination depending on the first and second
operating voltages stored on the first and second
storage capacitors according to the data signal.

[0013] The present invention will now be described by
way of further example only, with reference to the ac-
companying drawings in which:-

Fig. 1 shows a conventional OELD pixel driver circuit
using two transistors;
Fig. 2 shows a known current programmed OELD
driver circuit with threshold voltage compensation;
Fig. 3 illustrates the concept of a driver circuit includ-
ing a complementary pair of driver transistors for provid-
ing threshold voltage compensation in accord-

ance with the present invention;

Fig. 4 shows plots of characteristics for the comple-
mentary driver transistors illustrated in Fig. 3 for var-
ious levels of threshold voltages;

Fig. 5 shows a driver circuit arranged to operate as
a voltage driver circuit in accordance with a first em-
bodiment of the present invention.

Fig. 6 shows a driver circuit arranged to operate as
a current programmed driver circuit in accordance
with a second embodiment of the present invention;
Fig. 7 shows a current programmed driver circuit in
accordance with a third embodiment of the present
invention;

Figs 8 to 11 show SPICE simulation results for the
circuit illustrated in Fig. 6;

Fig. 12 is a schematic sectional view of a physical
implementation of an OEL element and driver accord-
ing to an embodiment of the present invention;
Fig. 13 is a simplified plan view of an OEL elemen-
tOEL display panel incorporating the present inven-
tion;

Fig. 14 is a schematic view of a mobile personal com-
puter incorporating a display device having a driver
according to the present invention;

Fig. 15 is a schematic view of a mobile telephone
incorporating a display device having a driver accord-
ing to the present invention,

Fig. 16 is a schematic view of a digital camera incor-
porating a display device having a driver according
to the present invention,

Fig. 17 illustrates the application of the driver circuit
of the present invention to a magnetic RAM, and
Fig. 18 illustrates an alternative application of the
driver circuit of the present invention to a magnetic
RAM, and

Fig. 19 illustrates the application of the driver circuit
of the present invention to a magnetoresistive ele-
ment.

[0014] The concept of a driver circuit according to the
present invention is illustrated in Fig. 3. An OEL element
is coupled between two transistors T_{12} and T_{15} which
operate, in combination, as an analog current control for
the current flowing through the OEL element. Transistor
 T_{12} is a p-channel transistor and transistor T_{15} is an n-
channel transistor which act therefore, in combination,
as a complementary pair for analog control of the current
through the OEL element.

[0015] As mentioned previously, one of the most im-
portant parameters in a TFT analog circuit design is the
threshold voltage V_T . Any variation, ΔV_T within a circuit
has a significant effect on the overall circuit performance.
Variations in the threshold voltage can be viewed as a
rigid horizontal shift of the source to drain current versus
the gate to source voltage characteristic for the transistor
concerned and are caused by the interface charge at the
gate of the transistor.

[0016] It has been realised with the present invention

that in an array of TFT devices, in view of the fabrication techniques employed, neighbouring or relatively close TFT's have a high probability of exhibiting the same or an almost similar value of threshold voltage ΔV_T . Furthermore, it has been realised that as the effects of the same ΔV_T on p-channel and n-channel TFT's are complementary, compensation for variations in threshold voltage ΔV_T can be achieved by employing a pair of TFT's, one p-channel TFT and one n-channel TFT, to provide analog control of the driving current flowing to the OEL element. The driving current can, therefore, be provided independently of any variation of the threshold voltage. Such a concept is illustrated in figure 3.

[0017] Figure 4 illustrates the variation in drain current, that is the current flowing through the OEL element shown in figure 3, for various levels of threshold voltage $\Delta V_T, \Delta V_{T1}, \Delta V_{T2}$, for the transistors T_{12} and T_{15} . Voltages V_1, V_2 and V_D are respectively the voltages appearing across transistor T_{12}, T_{15} and the OEL element from a voltage source V_{DD} . Assuming that the transistors T_{12} and T_{15} have the same threshold voltage and assuming that $\Delta V_T = 0$, then the current flowing through the OEL element is given by cross-over point A for the characteristics for the p-channel transistor T_{12} and the n-channel transistor T_{15} shown in figure 4. This is shown by value I_0 .

[0018] Assuming now that the threshold voltage of the p-channel and n-channel transistors changes to ΔV_{T1} , the OEL element current I_1 is then determined by cross-over point B. Likewise, for a variation in threshold voltage to ΔV_2 , the OEL element current I_2 is given by crossover point C. It can be seen from figure 4 that even with the variations in the threshold voltage there is minimal variation in the current flowing through the OEL element.

[0019] Figure 5 shows a pixel driver circuit configured as a voltage driver circuit. The circuit comprises p-channel transistor T_{12} and n-channel transistor T_{15} acting as a complementary pair to provide, in combination, an analog current control for the OEL element. The circuit includes respective storage capacitors C_{12} and C_{15} and respective switching transistors T_A and T_B coupled to the gates of transistors T_{12} and T_{15} . When transistors T_A and T_B are switched ON data voltage signals V_1 and V_2 are stored respectively in storage capacitors C_{12} and C_{15} when the pixel is not addressed. The transistors T_A and T_B function as pass gates under the selective control of addressing signals ϕ_1 and ϕ_2 applied to the gates of transistors T_A and T_B .

[0020] Figure 6 shows a driver circuit according to the present invention configured as a current programmed OEL element driver circuit. As with the voltage driver circuit, p-channel transistor T_{12} and n-channel transistor T_{15} are coupled so as to function as an analog current control for the OEL element. Respective storage capacitors C_1, C_2 and respective switching transistors T_1 and T_6 are provided for transistors T_{12} and T_{15} . The driving waveforms for the circuit are also shown in figure 6. Either transistors T_1, T_3 and T_6 , or transistor T_4 can be ON at any one time. Transistors T_1 and T_6 connect respectively

between the drain and gate of transistors T_{12} and T_{15} and switch in response to applied waveform V_{SEL} to toggle transistors T_{12} and T_{15} to act either as diodes or as transistors in saturation mode. Transistor T_3 is also connected to receive waveform V_{SEL} . Transistors T_1 and T_6 are both p-channel transistors to ensure that the signals fed through these transistors are at the same magnitude. This is to ensure that any spike currents through the OEL element during transitions of the waveform V_{SEL} are kept to a minimum.

[0021] The circuit shown in figure 6 operates in a similar manner to known current programmed pixel driver circuits in that a programming stage and a display stage are provided in each display period but with the added benefit that the drive current to the OEL element is controlled by the complementary opposite channel transistors T_{12} and T_{15} . Referring to the driving waveforms shown in figure 6, a display period for the driver circuit extends from time t_0 to time t_6 . Initially, transistor T_4 is ON and transistors T_1, T_3 and T_6 are OFF. Transistor T_4 is turned OFF at time t_1 by the waveform V_{GP} and transistors T_1, T_3 and T_6 are turned ON at time t_3 by the waveform V_{SEL} . With transistors T_1 and T_6 turned ON, the p-channel transistor T_{12} and the complementary n-channel transistor T_{15} act in a first mode as diodes. The driving waveform for the frame period concerned is available from the current source I_{DAT} at time t_2 and this is passed by the transistor T_3 when it switches on at time t_3 . The detected threshold voltages of transistors T_{12} and T_{15} are stored in capacitors C_1 and C_2 . These are shown as imaginary voltage sources ΔV_{T12} and ΔV_{T15} in figure 6.

[0022] Transistors T_1, T_3 and T_6 are then switched OFF at time t_4 and transistor T_4 is switched ON at time t_5 and the current through the OEL element is then provided from the source V_{DD} under the control of the p-channel and n-channel transistors T_{12} and T_{15} operating in a second mode, i.e. as transistors in saturation mode. It will be appreciated that as the current through the OEL element is controlled by the complementary p-channel and n-channel transistors T_{12} and T_{15} , any variation in threshold voltage in one of the transistors will be compensated by the other opposite channel transistor, as described previously with respect to figure 4.

[0023] In the current programmed driver circuit shown in figure 6, the switching transistor T_3 is coupled to the p-channel transistor T_{12} , with the source of the driving waveform I_{DAT} operating as a current source. However, the switching transistor T_3 may as an alternative be coupled to the n-channel transistor T_{15} as shown in figure 7, whereby I_{DAT} operates as a current sink. In all other respects the operation of the circuit shown in figure 7 is the same as for the circuit shown in figure 6.

[0024] Figures 8 to 11 show a SPICE simulation of an improved pixel driver circuit according to the present invention.

[0025] Referring to figure 8, this shows the driving waveforms I_{DAT}, V_{GP}, V_{SEL} and three values of threshold voltage, namely -1volt, 0volts and +1volt used for the

purposes of simulation to show the compensating effect provided by the combination of the p-channel and n-channel transistors for controlling the current through the OEL element. From figure 8, it can be seen that, initially the threshold voltage ΔV_T was set at -1volt, increasing to 0volts at 0.3×10^{-4} seconds and increasing again to +1volt at 0.6×10^{-4} seconds. However, it can be seen from figure 9 that even with such variations in the threshold voltage the driving current through the OEL element remains relatively unchanged.

[0026] The relative stability in the driving current through the OEL element can be more clearly seen in figure 10, which shows a magnified version of the response plots shown in figure 9.

[0027] It can be seen from figure 10 that, using a value of 0 volts as a base for the threshold voltage ΔV_T , that if the threshold voltage ΔV_T changes to -1volts there is a change of approximately 1.2% in the drive current through the OEL element and if the threshold voltage ΔV_T is changed to + 1volt, there is a reduction in drive current of approximately 1.7% compared to the drive current when the threshold voltage ΔV_T is 0 volts. The variation of drive current of 8.7% is shown for reference purposes only as such a variation can be compensated by gamma correction, which is well known in this art and will not therefore be described in relation to the present invention.

[0028] Figure 11 shows that for levels of I_{DAT} ranging from $0.2\mu A$ to $1.0\mu A$, the improved control of the OEL element drive current is maintained by the use of the p-channel and opposite n-channel transistors in accordance with the present invention.

[0029] It will be appreciated from the above description that the use of a p-channel transistor and an opposite n-channel transistor to provide, in combination, analog control of the drive current through an electroluminescent device provides improved compensation for the effects which would otherwise occur with variations in the threshold voltage of a single p-channel or n-channel transistor.

[0030] Preferably, the TFT n-channel and p-channel transistors are fabricated as neighbouring or adjacent transistors during the fabrication of an OEL element OEL display so as to maximise the probability of the complementary p-channel and n-channel transistors having the same value of threshold voltage ΔV_T . The p-channel and n-channel transistors may be further matched by comparison of their output characteristics.

[0031] Figure 12 is a schematic cross-sectional view of the physical implementation of the pixel driver circuit in an OEL element structure. In figure 12, numeral 132 indicates a hole injection layer, numeral 133 indicates an organic EL layer, and numeral 151 indicates a resist or separating structure. The switching thin-film transistor 121 and the n-channel type current-thin-film transistor 122 adopt the structure and the process ordinarily used for a low-temperature polysilicon thin-film transistor, such as are used for example in known thin-film transistor liquid crystal display devices such as a top-gate structure

and a fabrication process wherein the maximum temperature is $600^\circ C$ or less. However, other structures and processes are applicable.

[0032] The forward oriented organic EL display element 131 is formed by: the pixel electrode 115 formed of Al, the opposite electrode 116 formed of ITO, the hole injection layer 132, and the organic EL layer 133. In the forward oriented organic EL display element 131, the direction of current of the organic EL display device can be set from the opposite electrode 116 formed of ITO to the pixel electrode 115 formed of Al.

[0033] The hole injection layer 132 and the organic EL layer 133 may be formed using an ink-jet printing method, employing the resist 151 as a separating structure between the pixels. The opposite electrode 116 formed of ITO may be formed using a sputtering method. However, other methods may also be used for forming all of these components.

[0034] The typical layout of a full display panel employing the present invention is shown schematically in figure 13. The panel comprises an active matrix OEL element 200 with analogue current program pixels, an integrated TFT scanning driver 210 with level shifter, a flexible TAB tape 220, and an external analogue driver LSI 230 with an integrated RAM/controller. Of course, this is only one example of the possible panel arrangements in which the present invention can be used.

[0035] The structure of the organic EL display device is not limited to the one described here. Other structures are also applicable.

[0036] The improved pixel driver circuit of the present invention may be used in display devices incorporated in many types of equipment such as mobile displays e.g. mobile phones, laptop personal computers, DVD players, cameras, field equipment; portable displays such as desktop computers, CCTV or photo albums; or industrial displays such as control room equipment displays.

[0037] Several electronic apparatuses using the above organic electroluminescent display device will now be described.

<1: Mobile Computer>

[0038] An example in which the display device according to one of the above embodiments is applied to a mobile personal computer will now be described.

[0039] Figure 14 is an isometric view illustrating the configuration of this personal computer. In the drawing, the personal computer 1100 is provided with a body 1104 including a keyboard 1102 and a display unit 1106. The display unit 1106 is implemented using a display panel fabricated according to the present invention, as described above.

<2: Portable Phone>

[0040] Next, an example in which the display device is applied to a display section of a portable phone will be

described. Fig. 15 is an isometric view illustrating the configuration of the portable phone. In the drawing, the portable phone 1200 is provided with a plurality of operation keys 1202, an earpiece 1204, a mouthpiece 1206, and a display panel 100. This display panel 100 is implemented using a display panel fabricated according to the present invention, as described above.

<3: Digital Still Camera>

[0041] Next, a digital still camera using an OEL display device as a finder will be described. Fig. 16 is an isometric view illustrating the configuration of the digital still camera and the connection to external devices in brief.

[0042] Typical cameras sensitize films based on optical images from objects, whereas the digital still camera 1300 generates imaging signals from the optical image of an object by photoelectric conversion using, for example, a charge coupled device (CCD). The digital still camera 1300 is provided with an OEL element 100 at the back face of a case 1302 to perform display based on the imaging signals from the CCD. Thus, the display panel 100 functions as a finder for displaying the object. A photo acceptance unit 1304 including optical lenses and the CCD is provided at the front side (behind in the drawing) of the case 1302.

[0043] When a cameraman determines the object image displayed in the OEL element panel 100 and releases the shutter, the image signals from the CCD are transmitted and stored to memories in a circuit board 1308. In the digital still camera 1300, video signal output terminals 1312 and input/output terminals 1314 for data communication are provided on a side of the case 1302. As shown in the drawing, a television monitor 1430 and a personal computer 1440 are connected to the video signal terminals 1312 and the input/output terminals 1314, respectively, if necessary. The imaging signals stored in the memories of the circuit board 1308 are output to the television monitor 1430 and the personal computer 1440, by a given operation.

[0044] Examples of electronic apparatuses, other than the personal computer shown in Fig. 14, the portable phone shown in Fig. 15, and the digital still camera shown in Fig. 16, include OEL element television sets, viewfinder-type and monitoring-type video tape recorders, car navigation systems, pagers, electronic notebooks, portable calculators, word processors, workstations, TV telephones, point-of-sales system (POS) terminals, and devices provided with touch panels. Of course, the above OEL device can be applied to display sections of these electronic apparatuses.

[0045] The driver circuit of the present invention can be disposed not only in a pixel of a display unit but also in a driver disposed outside a display unit.

[0046] In the above, the driver circuit of the present invention has been described with reference to various display devices. The applications of the driver circuit of the present invention are much broader than just display

devices and include, for example, its use with a magnetoresistive RAM, a capacitance sensor, a charge sensor, a DNA sensor, a night vision camera and many other devices.

[0047] Figure 17 illustrates the application of the driver circuit of the present invention to a magnetic RAM. In figure 17 a magnetic head is indicated by the reference MH.

[0048] Figure 18 illustrates an alternative application of the driver circuit of the present invention to a magnetic RAM. In figure 18 a magnetic head is indicated by the reference MH.

[0049] Figure 19 illustrates the application of the driver circuit of the present invention to a magnetoresistive element. In figure 19 a magnetic head is indicated by the reference MH. and a magnetic resistor is indicated by the reference MR.

[0050] The foregoing description has been given by way of example only and it will be appreciated by a person skilled in the art that modifications can be made without departing from the scope of the appended claims.

Claims

1. A driver circuit, comprising:

a first storage capacitor (C_2);
 a second storage capacitor (C_1);
 an n-channel transistor (T_{15}), of which a gate is connected to the first storage capacitor;
 a p-channel transistor (T_{12}), of which a gate is connected to the second storage capacitor; and
 a current driven element disposed in a current path between the n-channel transistor and the p-channel transistor, wherein:

the driver circuit is arranged to cause, during a programming stage, a data current according to a data signal to flow through the p-channel transistor and the n-channel transistor so that a first operating voltage of the n-channel transistor and a second operating voltage of the p-channel transistor are stored respectively on the first storage capacitor and the second storage capacitor, and to cause, during a reproduction stage, the n-channel transistor and the p-channel transistor in combination to operatively control a driving current supplied to the current driven element depending on the first and second operating voltages stored on the first and second storage capacitors according to the data signal.

2. The driver circuit as claimed in claim 1, further comprising first switching means (T_3),

the first switching means and a source of the data current being connected so as to provide when operative a current source for the current driven element.

3. The driver circuit as claimed in claim 1, further comprising first switching means (T_3), the first switching means and a source of the data current being connected so as to provide when operative a current sink for the current driven element. 5
4. The driver circuit as claimed in any one of the preceding claims, further comprising a second switching means (T_1, T_6), the second switching means being connected to bias the n-channel transistor and the p-channel transistor to act as diodes respectively when the data current flows through the n-channel transistor and p-channel transistor. 10
5. The driver circuit as claimed in any one of the preceding claims, the n-channel transistor and the p-channel transistor being polysilicon thin film transistors. 15
6. The driver circuit as claimed in any one of the preceding claims, the current driven element being an electroluminescent element. 20
7. The driver circuit as claimed in any one of the preceding claims, the n-channel transistor and the p-channel transistor being arranged in close proximity to each other so as to maximise the probability that said two transistors have the same value of the threshold voltage. 25
8. The driver circuit according to any one of the preceding claims, the first storage capacitor being disposed between the source electrode and the gate electrode of the n-channel transistor, and the second storage capacitor being disposed between the source electrode and the gate electrode of the p-channel transistor. 30
9. An electro-optical device comprising the driver circuit according to any one of the preceding claims. 35
10. An electronic apparatus incorporating an electro-optical device according to claim 9. 40
11. A driving method of a driver circuit that is for a current driven element and that has an n-channel transistor (T_{15}), a p-channel transistor (T_{12}), the current driven element being disposed in a current path between the n-channel transistor and the p-channel transistor, a first storage capacitor (C_{15}) connected to a gate of the n-channel transistor, and a second storage capacitor (C_{12}) connected to a gate of the p-

channel transistor, comprising:

a programming step of storing a first operating voltage of the n-channel transistor on the first storage capacitor and a second operating voltage of the p-channel transistor on the second storage capacitor by supplying a data current according to a data signal to the n-channel transistor and the p-channel transistor; and a reproduction step of supplying a current to the current driven element, said current being controlled by the n-channel transistor and the p-channel transistor in combination depending on the first and second operating voltages stored on the first and second storage capacitors according to the data signal.

12. The driving method as claimed in claim 11, in the first step, the n-channel transistor and the p-channel transistor acting as a diode.
13. The driving method as claimed in claim 11 or claim 12, the current driven element being an electroluminescent element.

Patentansprüche

1. Treiberschaltung, umfassend:

einen ersten Speicherkondensator (C_2);
 einen zweiten Speicherkondensator (C_1);
 einen n-Kanal-Transistor (T_{15}), von dem ein Gate an den ersten Speicherkondensator angeschlossen ist;
 einen p-Kanal-Transistor (T_{12}), von dem ein Gate an den zweiten Speicherkondensator angeschlossen ist; und
 eins strombetriebenes Element, das in einem Strompfad zwischen dem n-Kanal-Transistor und dem p-Kanal-Transistor angeordnet ist, wobei:

die Treiberschaltung so angeordnet ist, dass während einer Programmierungsstufe ein Datenstrom entsprechend einem Datensignal veranlasst wird, durch den p-Kanal-Transistor und den n-Kanal-Transistor zu fließen, so dass eine erste Betriebsspannung des n-Kanal-Transistors und eine zweite Betriebsspannung des p-Kanal-Transistors in dem ersten Speicherkondensator beziehungsweise dem zweiten Speicherkondensator gespeichert werden, und während einer Wiedergabestufe der n-Kanal-Transistor und der p-Kanal-Transistor veranlasst werden, gemeinsam einen Trei-

- berstrom, der dem strombetriebenen Element abhängig von der ersten und zweiten Betriebsspannung zugeführt wird, die in den ersten und zweiten Speicherkondensatoren entsprechend dem Datensignal gespeichert sind, betriebsbereit zu steuern.
2. Treiberschaltung nach Anspruch 1, des Weiteren umfassend ein erstes Schaltmittel (T_3), wobei das erste Schaltmittel und eine Quelle des Datenstroms so verbunden sind, dass sie im betriebsbereiten Zustand eine Stromquelle für das strombetriebene Element bereitstellen.
 3. Treiberschaltung nach Anspruch 1, des Weiteren umfassend ein erstes Schaltmittel (T_3), wobei das erste Schaltmittel und eine Quelle des Datenstroms so verbunden sind, dass sie im betriebsbereiten Zustand eine Stromsenke für das strombetriebene Element bereitstellen.
 4. Treiberschaltung nach einem der vorangehenden Ansprüche, des Weiteren umfassend ein zweites Schaltmittel (T_1, T_6), wobei das zweite Schaltmittel zum Vorspannen des n-Kanal-Transistors und des p-Kanal-Transistors angeschlossen ist, so dass diese jeweils als Dioden dienen, wenn der Datenstrom durch den n-Kanal-Transistor und den p-Kanal-Transistor fließt.
 5. Treiberschaltung nach einem der vorangehenden Ansprüche, wobei der n-Kanal-Transistor und der p-Kanal-Transistor Polysilizium-Dünnschichttransistoren sind.
 6. Treiberschaltung nach einem der vorangehenden Ansprüche, wobei das strombetriebene Element ein elektrolumineszentes Element ist.
 7. Treiberschaltung nach einem der vorangehenden Ansprüche, wobei der n-Kanal-Transistor und der p-Kanal-Transistor in unmittelbarer Nähe zueinander angeordnet sind, so dass die Wahrscheinlichkeit maximiert ist, dass die zwei Transistoren denselben Wert der Schwellenspannung haben.
 8. Treiberschaltung nach einem der vorangehenden Ansprüche, wobei der erste Speicherkondensator zwischen der Source-Elektrode und der Gate-Elektrode des n-Kanal-Transistors angeordnet ist, und der zweite Speicherkondensator zwischen der Source-Elektrode und der Gate-Elektrode des p-Kanal-Transistors angeordnet ist.
 9. Elektrooptische Vorrichtung, umfassend die Treiberschaltung nach einem der vorangehenden Ansprüche.
 10. Elektronisches Gerät mit einer elektrooptischen Vorrichtung nach Anspruch 9.
 11. Ansteuerungsverfahren einer Treiberschaltung für ein strombetriebenes Element, die einen n-Kanal-Transistor (T_{15}), einen p-Kanal-Transistor (T_{12}) aufweist, wobei das strombetriebene Element in einem Strompfad zwischen dem n-Kanal-Transistor und dem p-Kanal-Transistor angeordnet ist, sowie einen ersten Speicherkondensator (C_{15}), der an ein Gate des n-Kanal-Transistors angeschlossen ist, und einen zweiten Speicherkondensator (C_{12}), der an ein Gate des p-Kanal-Transistors angeschlossen ist, umfassend:
 - einen Programmierungsschritt zum Speichern einer ersten Betriebsspannung des n-Kanal-Transistors in dem ersten Speicherkondensator und einer zweiten Betriebsspannung des p-Kanal-Transistors in dem zweiten Speicherkondensator durch Zuleiten eines Datenstroms entsprechend einem Datensignal zu dem n-Kanal-Transistor und dem p-Kanal-Transistor; und
 - einen Widergabeschritt zum Zuleiten eines Stroms zu dem strombetriebenen Element, wobei der Strom gemeinsam von dem n-Kanal-Transistor und dem p-Kanal-Transistor abhängig von der ersten und zweiten Betriebsspannung, die in den ersten und zweiten Speicherkondensatoren entsprechend dem Datensignal gespeichert ist, gesteuert wird.
 12. Ansteuerungsverfahren nach Anspruch 11 wobei im ersten Schritt der n-Kanal-Transistor und der p-Kanal-Transistor als eine Diode wirken.
 13. Ansteuerungsverfahren nach Anspruch 11 oder Anspruch 12, wobei das strombetriebene Element ein elektrolumineszentes Element ist.

Revendications

1. Circuit d'attaque, comprenant :

- un premier condensateur de stockage (C_2) ;
- un deuxième condensateur de stockage (C_1) ;
- un transistor à canal n (T_{15}) dont une grille est connectée au premier condensateur de stockage ;
- un transistor à canal p (T_{12}) dont une grille est connectée au deuxième condensateur de stockage ; et
- un élément commandé par courant disposé dans un trajet de courant entre le transistor à

canal n et le transistor à canal p, dans lequel :

le circuit d'attaque est étudié pour :

faire en sorte, pendant la phase de programmation, qu'un courant de données en fonction d'un signal de données circule à travers le transistor à canal p et le transistor à canal n de manière à ce qu'une première tension de service du transistor à canal n et une deuxième tension de service du transistor à canal p soient respectivement stockées dans le premier condensateur de stockage et le deuxième condensateur de stockage, et

faire en sorte, pendant une phase de reproduction, que le transistor à canal n et le transistor à canal p en combinaison régulent de manière opérative un courant d'attaque alimentant l'élément commandé par courant en fonction des première et deuxième tensions de service stockées dans les premier et deuxième condensateurs de stockage en fonction du signal de données.

2. Circuit d'attaque tel que revendiqué par la revendication 1, comprenant par ailleurs un premier moyen de commutation (T_3), le premier moyen de commutation et une source du courant de données étant connectés de manière à fournir, lorsque opératifs, une source de courant pour l'élément commandé par courant.

3. Circuit d'attaque tel que revendiqué par la revendication 1, comprenant par ailleurs un premier moyen de commutation (T_3), le premier moyen de commutation et une source du courant de données étant connectés de manière à fournir, lorsque opératifs, un écoulement de courant pour l'élément commandé par courant.

4. Circuit d'attaque tel que revendiqué par l'une quelconque des revendications précédentes, comprenant par ailleurs un deuxième moyen de commutation (T_1 , T_6), le deuxième moyen de commutation étant connecté afin de polariser le transistor à canal n et le transistor à canal p afin qu'ils agissent respectivement en tant que diodes lorsque le courant de données circule à travers le transistor à canal n et le transistor à canal p.

5. Circuit d'attaque tel que revendiqué par l'une quelconque des revendications précédentes, le transistor à canal n et le transistor à canal p étant des tran-

sistors à couche mince en polysilicium.

6. Circuit d'attaque tel que revendiqué par l'une quelconque des revendications précédentes, l'élément commandé par courant étant un élément électroluminescent.

7. Circuit d'attaque tel que revendiqué par l'une quelconque des revendications précédentes, le transistor à canal n et le transistor à canal p étant disposés à proximité immédiate l'un de l'autre de manière à maximiser la probabilité que lesdits deux transistors présentent la même valeur de tension de seuil.

8. Circuit d'attaque selon l'une quelconque des revendications précédentes, le premier condensateur de stockage étant disposé entre l'électrode de source et l'électrode de grille du transistor à canal n, et le deuxième condensateur de stockage étant disposé entre l'électrode de source et l'électrode de grille du transistor à canal p.

9. Dispositif électro-optique comprenant le circuit d'attaque selon l'une quelconque des revendications précédentes.

10. Appareil électronique comprenant un dispositif électro-optique selon la revendication 9.

11. Procédé de commande d'un circuit d'attaque destiné à un élément commandé par courant et ayant un transistor à canal n (T_{15}), un transistor à canal p (T_{12}), l'élément commandé par courant étant disposé dans un trajet de courant entre le transistor à canal n et le transistor à canal p, un premier condensateur de stockage (C_{15}) connecté à une grille du transistor à canal n, et un deuxième condensateur de stockage (C_{12}) connecté à une grille du transistor à canal p, comprenant :

une étape de programmation consistant à stocker une première tension de service du transistor à canal n dans le premier condensateur de stockage et une deuxième tension de service du transistor à canal p dans le deuxième condensateur de stockage en fournissant un courant de données en fonction d'un signal de données au transistor à canal n et au transistor à canal p, et

une étape de reproduction consistant à fournir un courant à l'élément commandé par courant, ledit courant étant régulé par le transistor à canal n et le transistor à canal p en combinaison en fonction des première et deuxième tensions de service stockées dans les premier et deuxième condensateurs de stockage en fonction du signal de données.

12. Procédé de commande tel que revendiqué par la revendication 11, lors de la première étape, le transistor à canal n et le transistor à canal p agissant en tant que diodes.

5

13. Procédé de commande tel que revendiqué par la revendication 11 ou la revendication 12, l'élément commandé par courant étant un élément électroluminescent.

10

15

20

25

30

35

40

45

50

55

Fig.1.

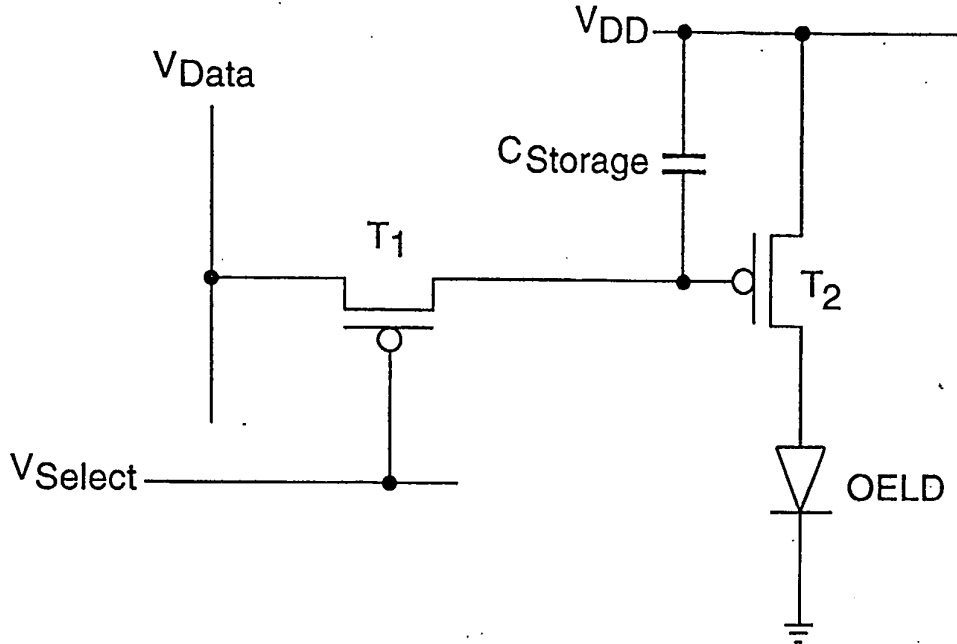

Fig.2.

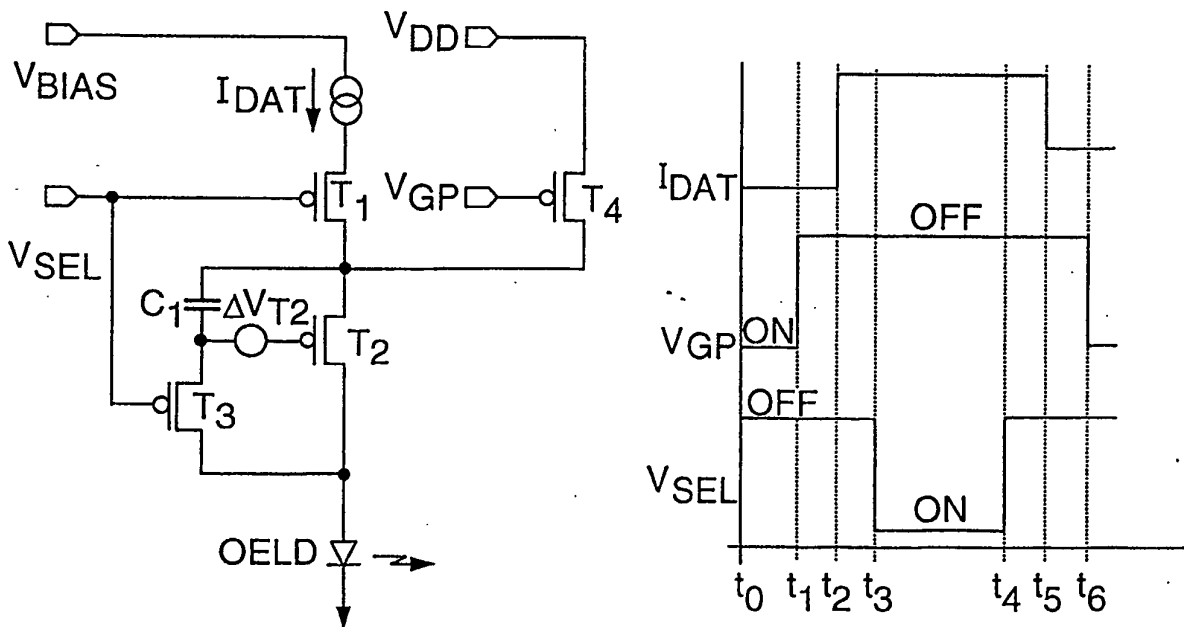

Fig.3.

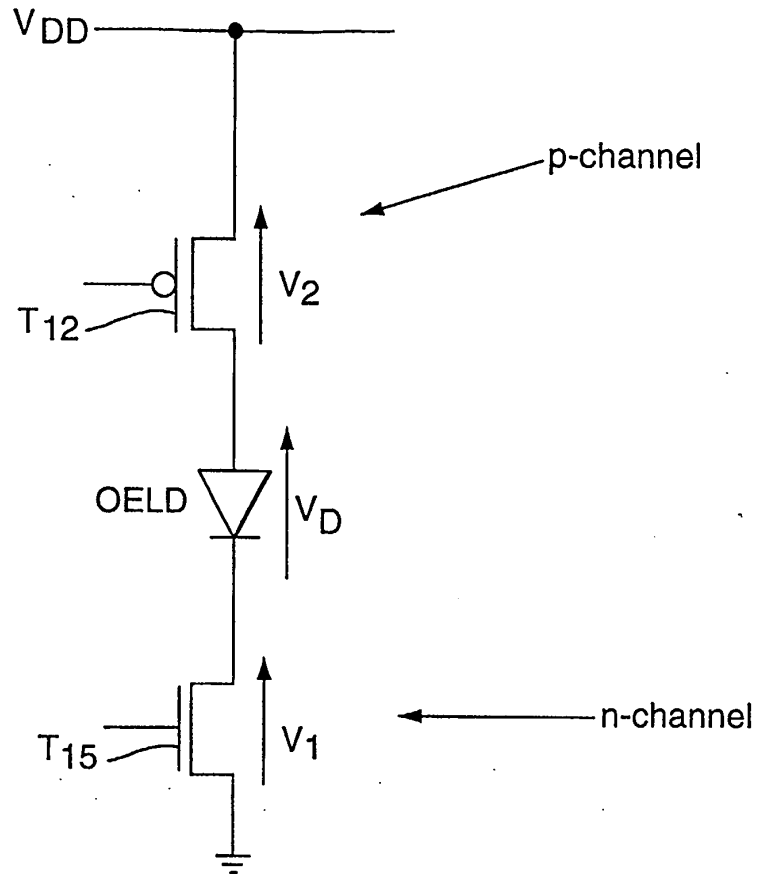

Fig.4.

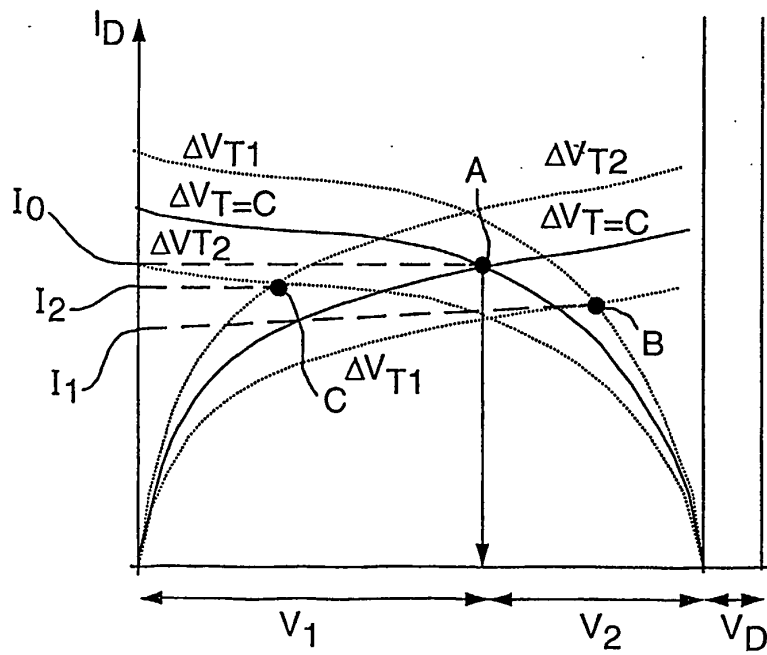

Fig.5.

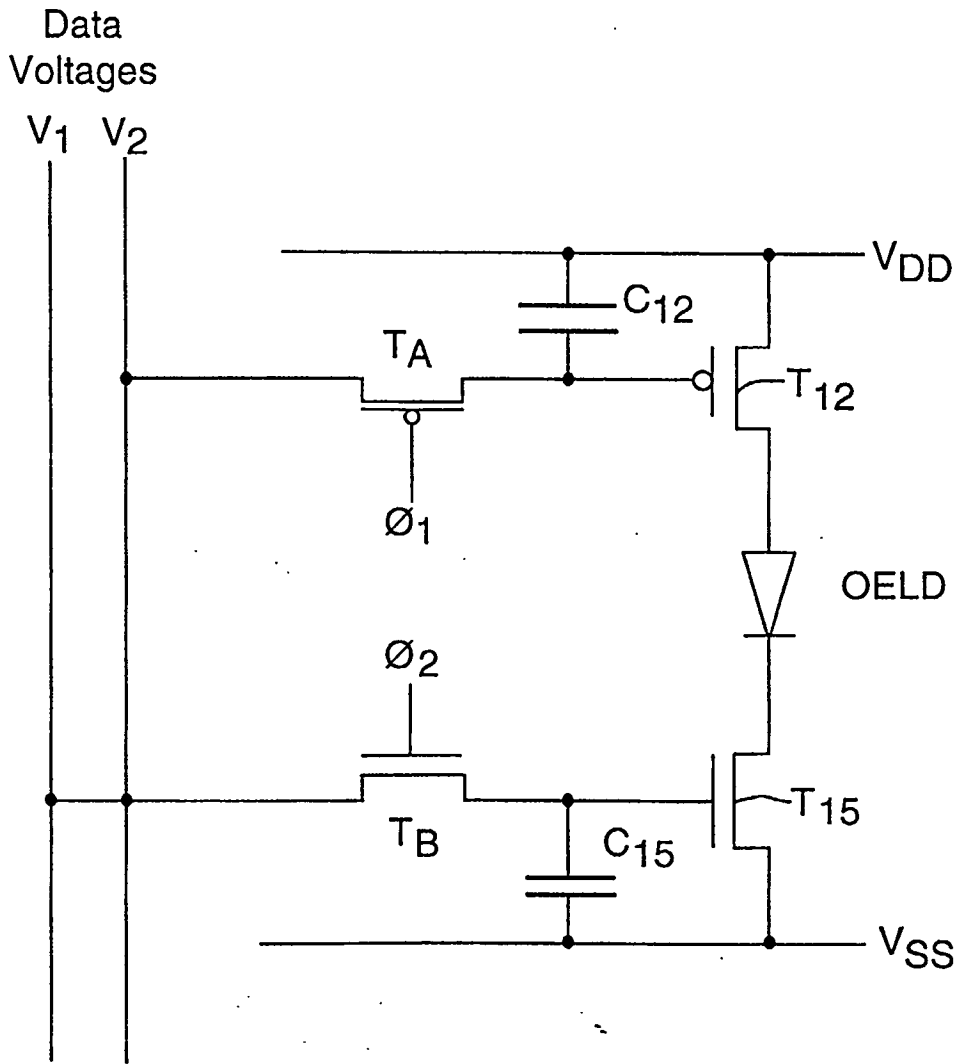
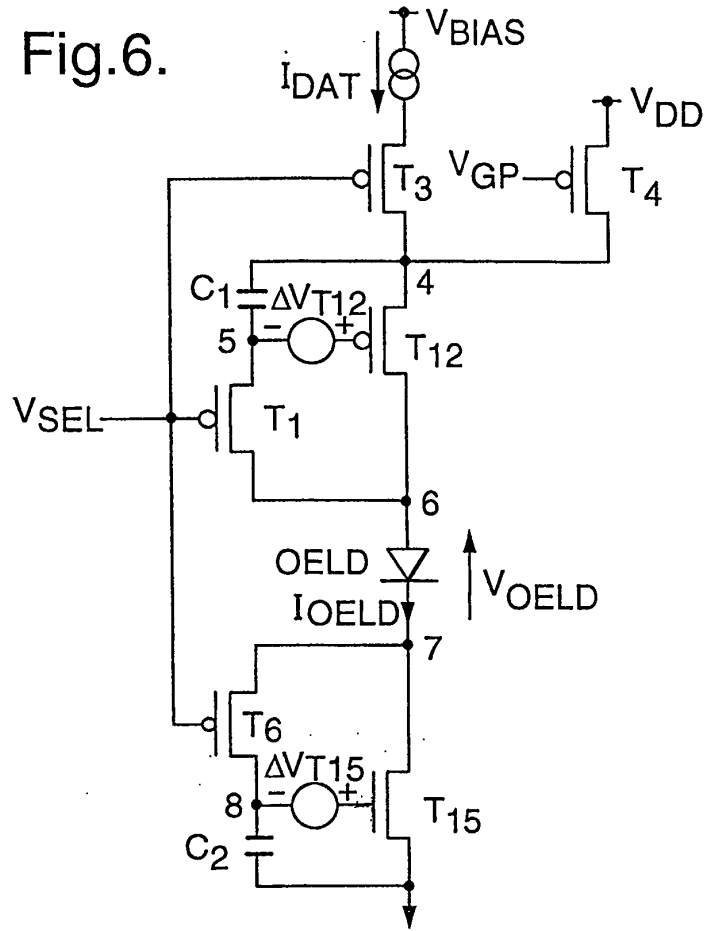

Fig.6.



DRIVING WAVEFORM

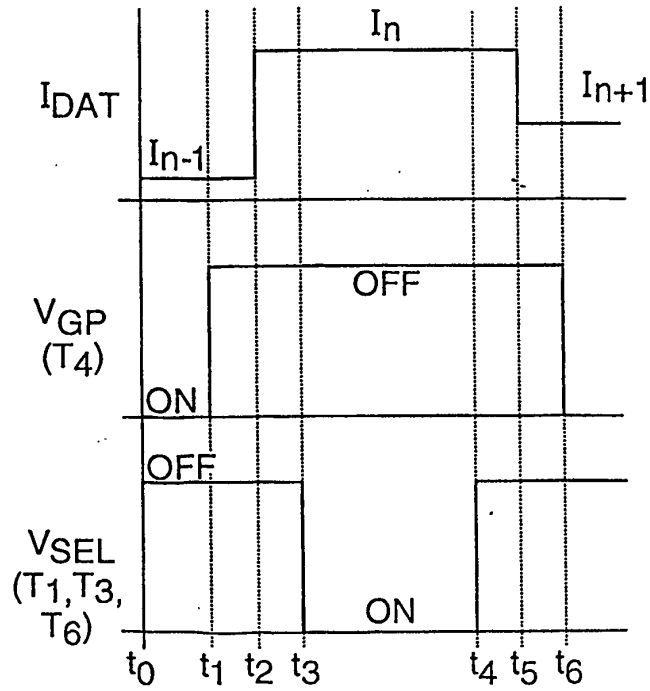

Fig.7.

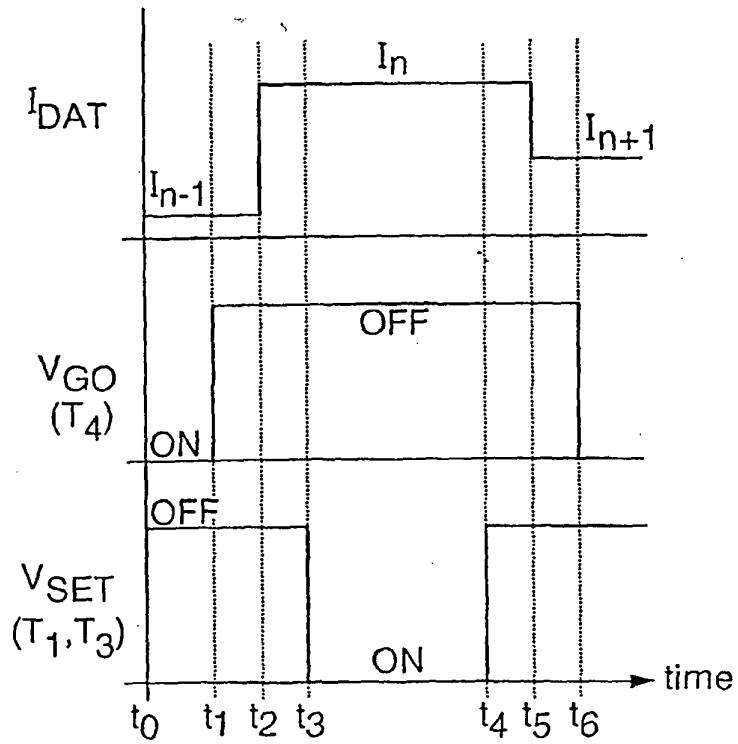
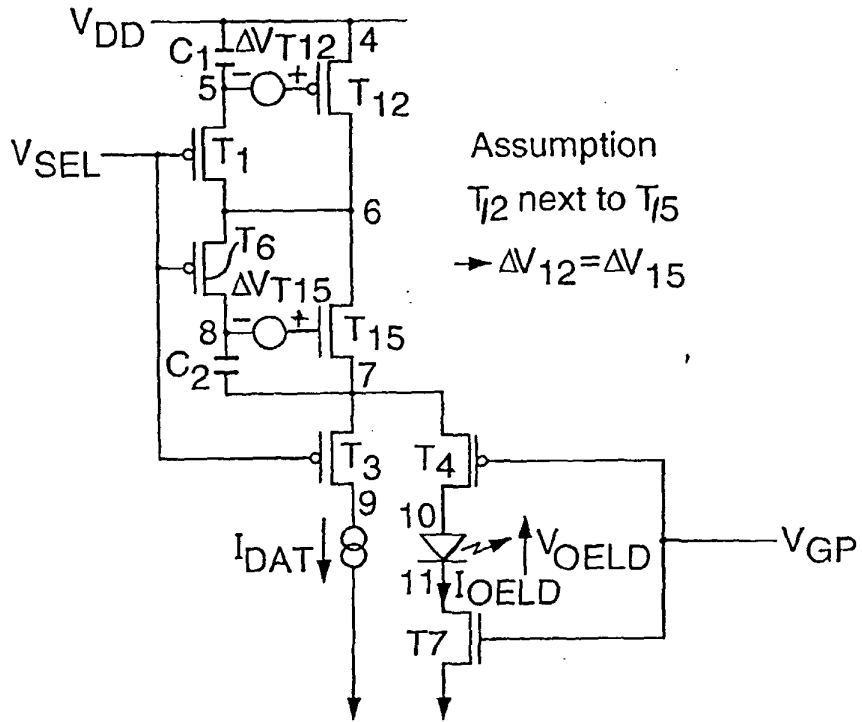

Fig.8. SPICE Simulation Result ($V_{DD} = 12.5V$, $I_{DAT} = 1\mu A$)

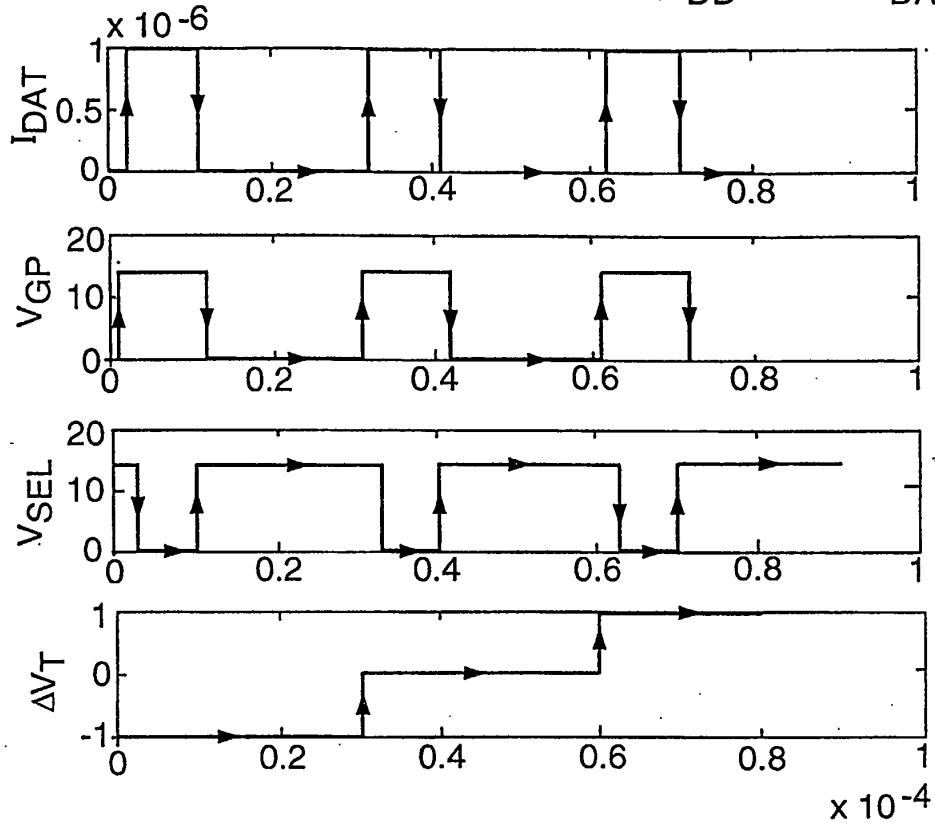
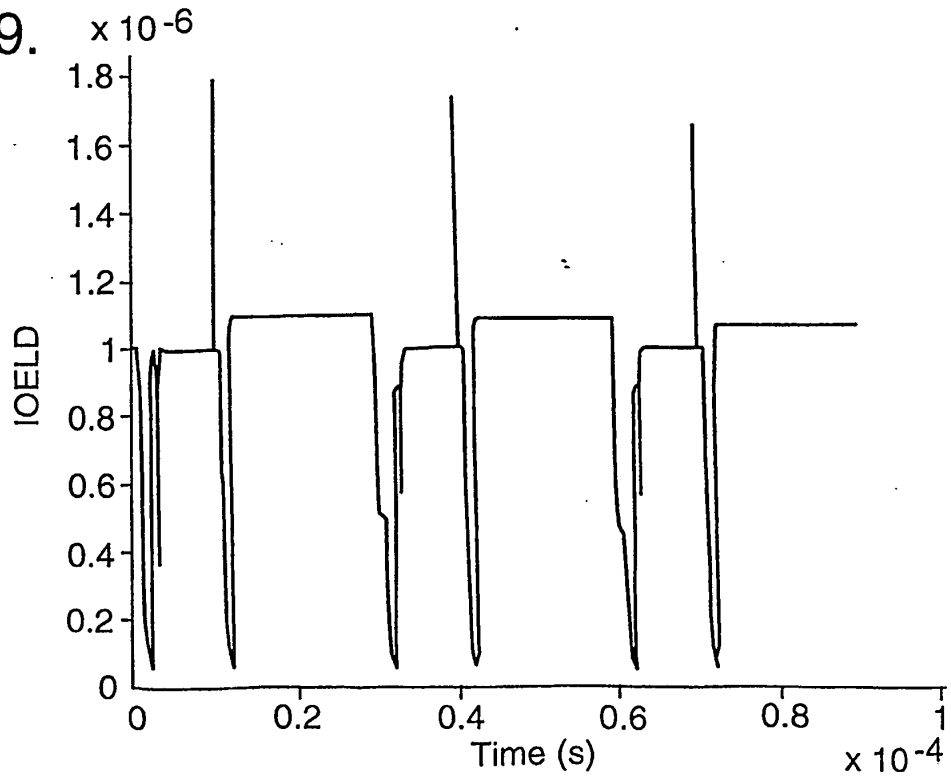

Fig.9.



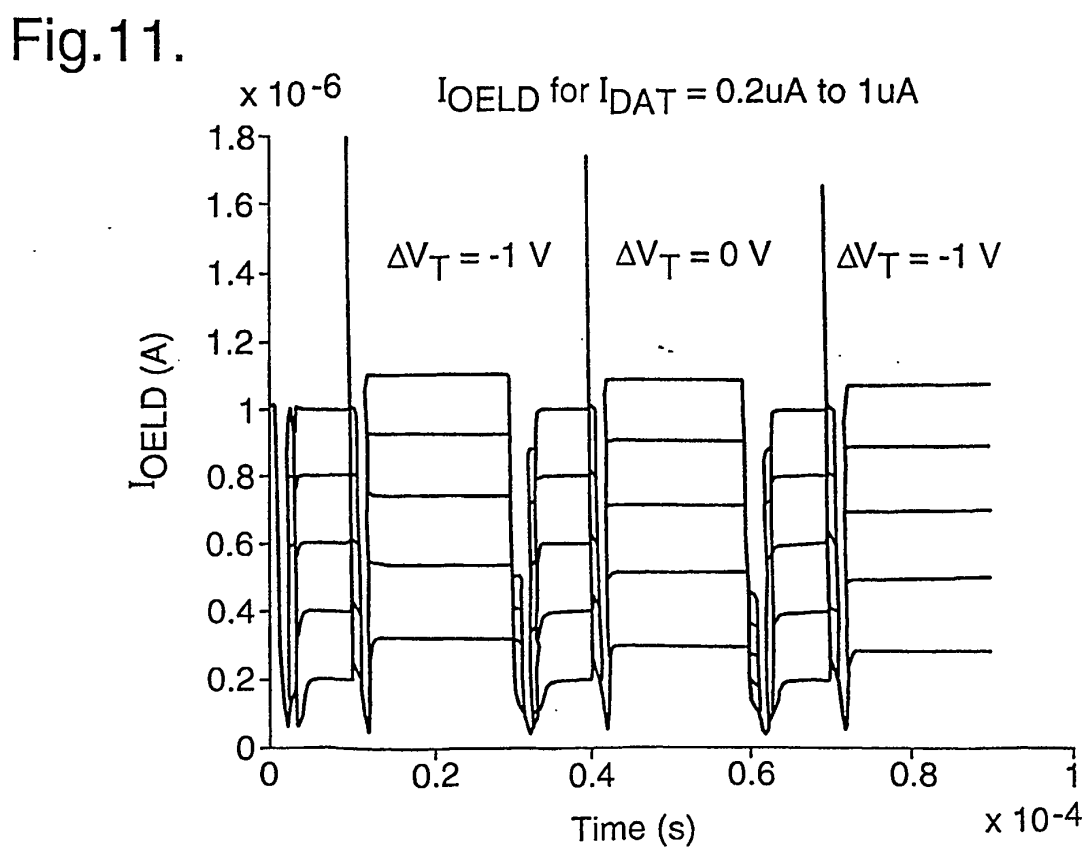
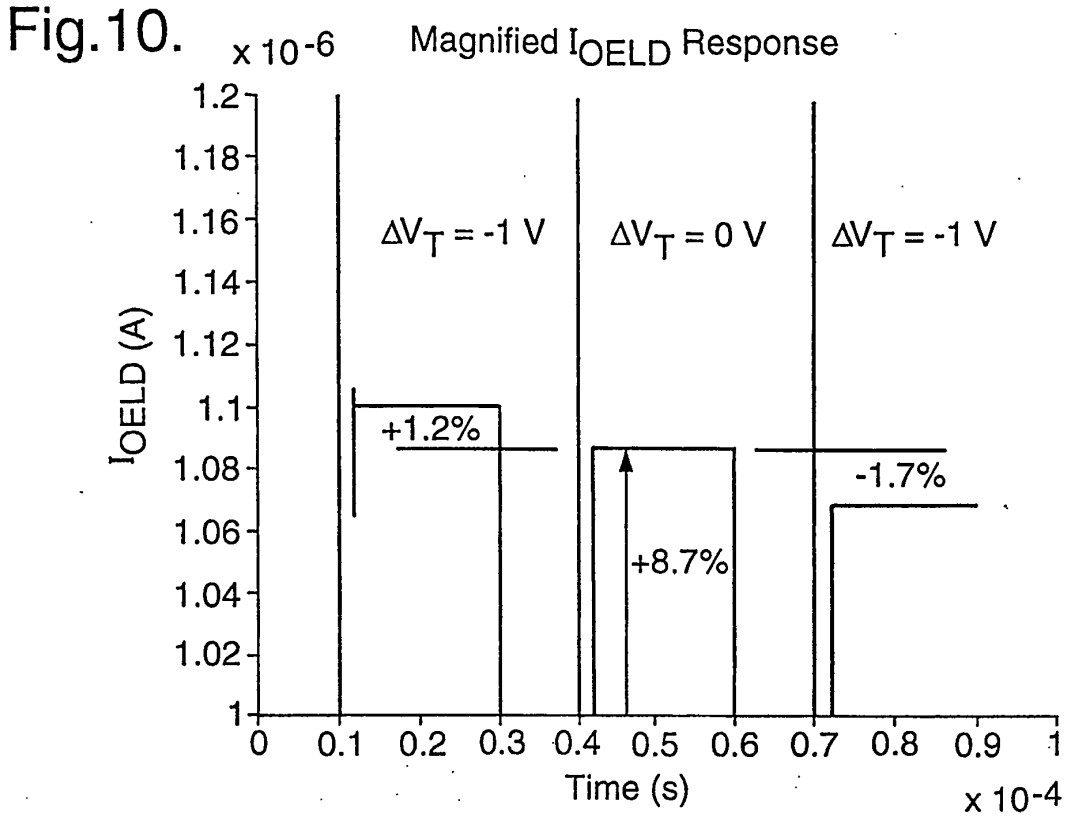

Figure 12

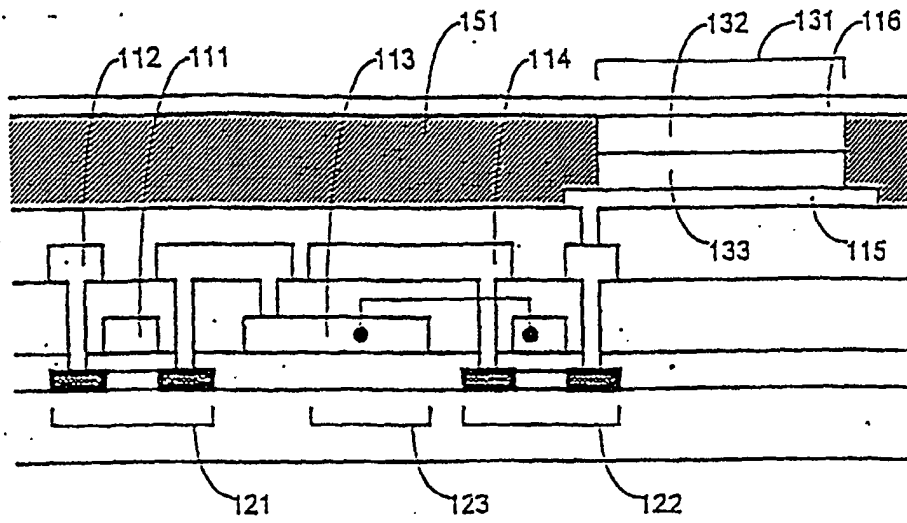

Figure 13

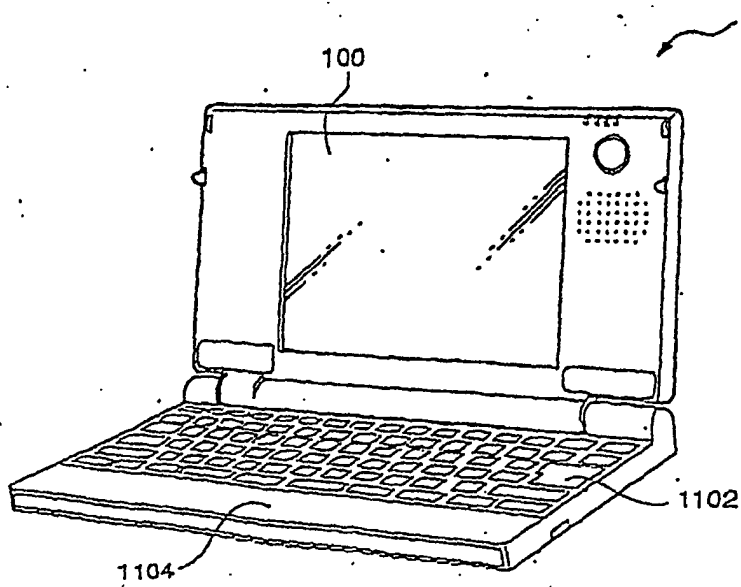
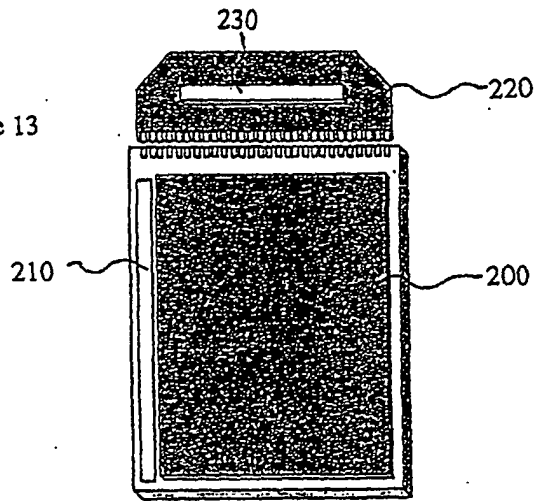

Figure 14

Figure 15

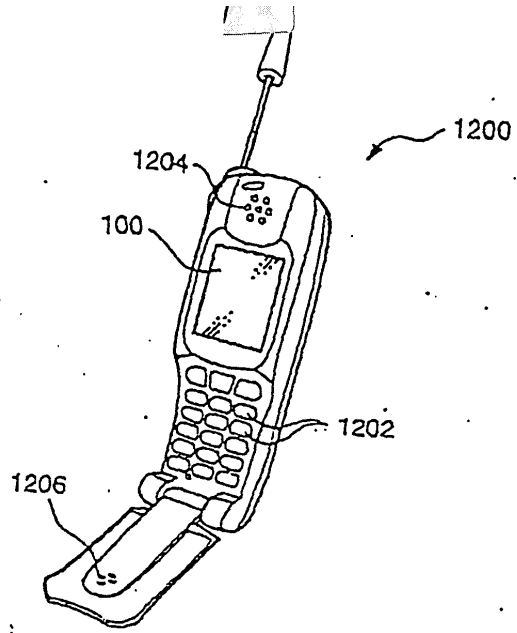
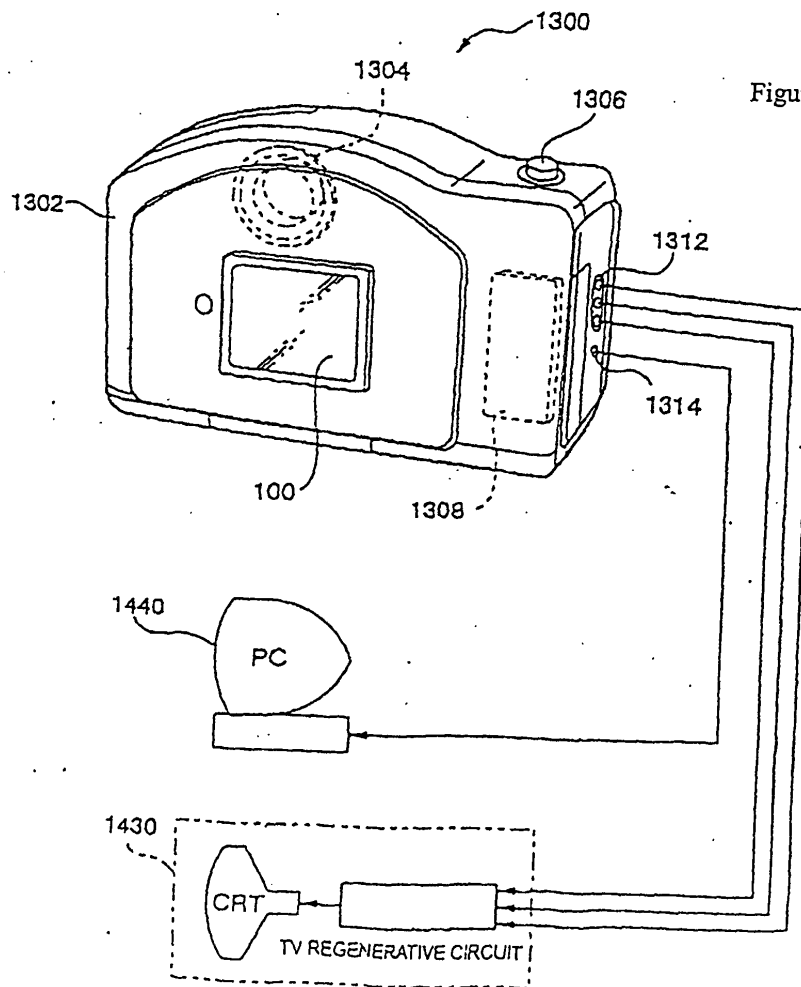

Figure 16



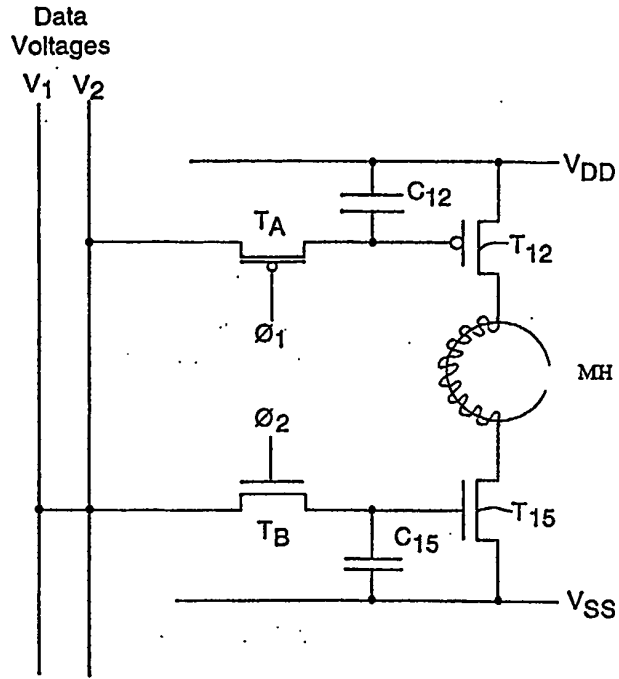

Figure 17

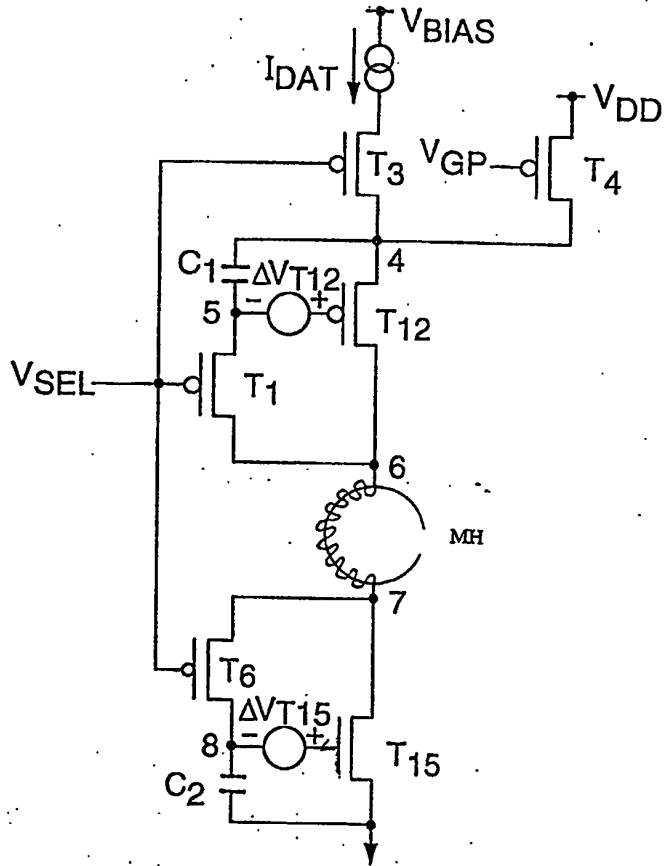

Figure 18

REFERENCES CITED IN THE DESCRIPTION

This list of references cited by the applicant is for the reader's convenience only. It does not form part of the European patent document. Even though great care has been taken in compiling the references, errors or omissions cannot be excluded and the EPO disclaims all liability in this regard.

Patent documents cited in the description

- US 3443151 A [0008]
- EP 0597226 A [0009]
- WO 9965011 A [0009]

| | | | |
|----------------|--|---------|------------|
| 专利名称(译) | 电流驱动的电光装置，例如，有机电致发光显示器，具有互补的驱动晶体管以抵消阈值电压变化 | | |
| 公开(公告)号 | EP1170719B1 | 公开(公告)日 | 2011-09-14 |
| 申请号 | EP2001305904 | 申请日 | 2001-07-09 |
| [标]申请(专利权)人(译) | 精工爱普生株式会社 | | |
| 申请(专利权)人(译) | SEIKO EPSON CORPORATION | | |
| 当前申请(专利权)人(译) | SEIKO EPSON CORPORATION | | |
| [标]发明人 | TAM SIMON | | |
| 发明人 | TAM, SIMON | | |
| IPC分类号 | G09G3/32 | | |
| CPC分类号 | G09G3/325 G09G2300/0417 G09G2300/0819 G09G2300/0852 G09G2300/0861 G09G2320/0276 G09G2320/043 | | |
| 代理机构(译) | 斯特，CLIFFORD MARK | | |
| 优先权 | 2000016815 2000-07-07 GB | | |
| 其他公开文献 | EP1170719A1 | | |
| 外部链接 | Espacenet | | |

摘要(译)

驱动电路包括p沟道晶体管和作为互补晶体管对连接的n沟道晶体管，以提供对电流驱动元件，优选有机电致发光元件(OEL元件)的驱动电流的模拟控制。具有相反沟道的晶体管补偿阈值电压 ΔV_T 的任何变化，并因此向OEL元件提供相对独立于 ΔV_T 的驱动电流。互补的晶体管对可以应用于电压驱动或电流驱动像素驱动器电路。

Fig.1.

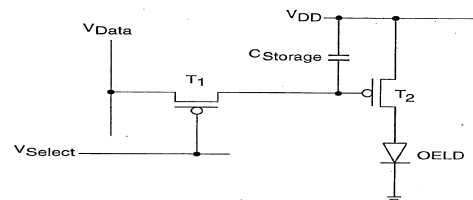

Fig.2.

