



## SERVO FEEDBACK CONTROL BASED ON DESIGNATED SCANNING SERVO BEAM IN SCANNING BEAM DISPLAY SYSTEMS WITH LIGHT-EMITTING SCREENS

### Priority Claim and Related Patent Application

5 [0001] This PCT application claims priority from and benefits of U.S. Patent Application No. 11/769,580 entitled "Servo Feedback Control Based on Invisible Scanning Servo Beam in Scanning Beam Display Systems with Light-Emitting Screens" and filed on June 27, 2007. The disclosure of U.S. Patent Application No. 11/769,580 is incorporated by reference as part of the specification of this PCT application.

### Background

10 [0002] This patent application relates to scanning-beam display systems.

[0003] In a scanning-beam display system, an optical beam can be scanned over a screen to form images on the screen. Many display systems such as laser display systems use a polygon scanner with multiple reflective facets to provide horizontal scanning and a vertical scanning mirror such as a galvo-driven mirror to provide vertical scanning. In operation, one facet of the polygon scanner scans one horizontal line as the polygon scanner spins to change the orientation and position of the facet and the next facet scans the next horizontal line. The horizontal scanning and the vertical scanning are synchronized to each other to project images on the screen.

### Summary

20 [0004] This patent application describes, among others, implementations of display systems and devices based on scanning light on a light-emitting screen under optical excitation. The described display systems use light-emitting screens under optical excitation and at least one excitation optical beam to excite one or more light-emitting materials on a screen which emit light to form images. Servo control mechanisms for such display systems are described based on a designated servo beam that is scanned over the screen by the same scanning module that scans the image-carrying excitation optical beam. This designated servo beam is used to provide servo feedback control over the scanning excitation beam to ensure proper optical alignment and accurate delivery of optical pulses in the excitation beam during normal display operation. In some implementations, multiple lasers can be used to simultaneously scan multiple excitation laser beams on the screen. For example, the multiple laser beams can illuminate one screen segment at a time and sequentially scan multiple screen segments to complete a full screen.

35 [0005] In one implementation, a scanning beam display system includes a light module to direct and scan at least one excitation beam having optical pulses that carry image

information and at least one servo beam at a servo beam wavelength different from a wavelength of the excitation beam; a screen positioned to receive the scanning excitation beam and the servo beam and comprising a light-emitting layer of parallel light-emitting stripes which absorb light of the excitation beam to emit visible light to produce images  
5 carried by the scanning excitation beam, the screen configured to reflect light of the servo beam towards the light module to produce servo feedback light; and an optical servo sensor module positioned to receive the servo feedback light and to produce a servo feedback signal indicative of positioning of the servo beam on the screen. The light module is responsive to the positioning of the servo beam on the screen in the servo feedback signal to adjust timing  
10 of the optical pulses carried by the scanning excitation beam to control the spatial alignment of spatial positions of the optical pulses in the excitation beam on the screen.

**[0006]** As an example, the screen in the above system can include servo feedback marks that have facets facing the excitation light source that are specularly reflective to light of the servo beam, and areas outside the servo feedback marks that are diffusively reflective to light  
15 of the servo beam. In this example, the system includes a Fresnel lens located between the screen and the light module to direct the scanning servo beam and excitation beam to be at a substantially normal incidence to the screen. The Fresnel lens has an optic axis symmetrically in a center of the Fresnel lens to be parallel to and offset from an optic axis of the light module to direct light of the servo beam that is specularly reflected by a servo  
20 feedback mark into the optical servo sensor while light of the servo beam that is diffusely reflected by the screen outside a servo feedback mark is spread by the Fresnel lens over an area greater than the optical servo sensor to direct a fraction of diffusely reflected light of the servo beam into the optical servo sensor.

**[0007]** In another implementation, a method for controlling a scanning beam display  
25 system includes scanning one or more excitation beams modulated with optical pulses to carry images on a screen to excite parallel light-emitting strips to emit visible light which forms the images; scanning a servo beam at an optical wavelength different from an optical wavelength of the one or more excitation beams, on the screen; detecting light of the servo beam from the screen to obtain a servo signal indicative of positioning of the servo beam on  
30 the screen; and, in response to the positioning of the servo beam on the screen, controlling the one or more scanning excitation beams to control the spatial alignment of spatial positions of the optical pulses in each excitation beam on the screen.

**[0008]** In another implementation, a scanning beam display system, includes an excitation light source to produce at least one excitation beam having optical pulses that carry

image information; a servo light source to produce at least one servo beam at a servo beam wavelength that is invisible; a beam scanning module to receive the excitation beam and the servo beam and to scan the excitation beam and the servo beam; and a light-emitting screen positioned to receive the scanning excitation beam and the servo beam. The screen includes a  
5 light-emitting area which comprises (1) parallel light-emitting stripes which absorb light of the excitation beam to emit visible light to produce images carried by the scanning excitation beam, and (2) stripe dividers parallel to and spatially interleaved with the light-emitting stripes with each stripe divider being located between two adjacent stripes. Each stripe divider is optically reflective. An optical servo sensor is positioned to receive light of the  
10 servo beam scanning on the screen including light reflected by the stripe dividers and to produce a monitor signal indicative of positioning of the servo beam on the screen. This system includes a control unit operable to, in response to the positioning of the servo beam on the screen, adjust timing of the optical pulses carried by the scanning excitation beam in response to the monitor signal based on a relation between the servo beam and the excitation  
15 beam to control the spatial alignment of spatial positions of the optical pulses in the excitation beam on the screen.

**[0009]** In another implementation, a scanning beam display system includes a light-emitting screen comprising a light-emitting area which comprises (1) parallel light-emitting stripes which absorb excitation light to emit visible light, and (2) optically reflective stripe  
20 dividers parallel to and spatially interleaved with the light-emitting stripes with each stripe divider being located between two adjacent stripes. Excitation lasers are provided to produce excitation laser beams of the excitation light and at least one servo light source fixed in position relative to the excitation lasers is provided to produce at least one servo beam at a servo beam wavelength that is invisible. This system also includes a beam scanning module  
25 to receive the excitation laser beams and the servo beam and to scan the excitation laser beams and the servo beam; at least one first optical servo sensor positioned to receive light of the servo beam reflected from the screen to produce a first monitor signal indicative of positioning of the servo beam on the screen; at least one second optical servo sensor positioned to receive light of the excitation laser beams reflected from the screen to produce a  
30 second monitor signal indicative of positioning of each excitation laser beam on the screen; and a control unit operable to, in response to the first and the second monitor signals, adjust timing of the optical pulses carried by each excitation laser beam based on a relation between the servo beam and each excitation laser beam to control the spatial alignment of spatial positions of the optical pulses in the excitation beam on the screen.

[0010] In yet another implementation, a method for controlling a scanning beam display system includes scanning at least one excitation beam modulated with optical pulses on a screen with parallel light-emitting stripes in a beam scanning direction perpendicular to the light-emitting stripes to excite the fluorescent strips to emit visible light which forms images.

5 The screen comprises stripe dividers parallel to and spatially interleaved with the light-emitting stripes with each stripe divider being located between two adjacent stripes and each stripe divider is optically reflective. This method also includes: scanning a servo beam, which is invisible, along with the excitation beam on the screen; detecting light of the scanning servo beam from the screen including light produced by the stripe dividers to obtain  
10 a monitor signal indicative of positioning of the servo beam on the screen; and, in response to the positioning of the servo beam on the screen, adjusting timing of the optical pulses carried by the scanning excitation beam based on a relation between the servo beam and the excitation beam to control the spatial alignment of spatial positions of the optical pulses in the excitation beam on the screen.

15 [0011] These and other examples and implementations are described in detail in the drawings, the detailed description and the claims.

### Brief Description of the Drawings

[0012] FIG. 1 shows an example scanning laser display system having a light-emitting screen made of laser-excitabile light-emitting materials (e.g., phosphors) emitting colored lights under excitation of a scanning laser beam that carries the image information to be displayed.

[0013] FIGS. 2A and 2B show one example screen structure with parallel light-emitting stripes and the structure of color pixels on the screen in FIG. 1.

[0014] FIG. 3 shows an example implementation of the laser display system in FIG. 1 in a pre-objective scanning configuration having multiple lasers that direct multiple laser beams on the screen.

[0015] FIG. 4 shows an example implementation of a post-objective scanning beam display system based on the laser display system in FIG. 1. FIG. 5 shows one example for simultaneously scanning consecutive scan lines with multiple excitation laser beams and an invisible servo beam.

[0016] FIG. 5A shows a map of beam positions on the screen produced by a laser array of thirty-six excitation lasers and one IR servo laser when a vertical galvo scanner and a horizontal polygon scanner are at their respective null positions.

[0017] FIG. 6 shows one example of a scanning display system using a servo feedback control based on a scanning servo beam.

[0018] FIG. 7 shows an example of a servo detector for detecting the servo feedback light in FIG. 6.

[0019] FIGS. 8 and 9 show two screen examples for the servo control based on a scanning servo beam.

[0020] FIG. 10 shows optical power of servo light having optical signals corresponding to stripe dividers on the screen.

[0021] FIG. 11 shows an example of a screen having peripheral reference mark regions that include servo reference marks that produce feedback light for various servo control functions.

[0022] FIG. 12 shows a start of line reference mark in a peripheral reference mark region to provide a reference for the beginning of the active fluorescent area on the screen.

[0023] FIGS. 13 and 14 show optical power of servo light having optical signals corresponding to stripe dividers, the start of line reference mark and end of line reference mark on the screen

[0024] FIGS. 15, 16 and 17 show examples of a use of a sampling clock signal to measure position data of stripe dividers on the screen using servo feedback light from the excitation beam or the servo beam.

5 [0025] FIG. 18A shows an example of a vertical beam position reference mark for the screen in FIG. 11.

[0026] FIGS. 18B and 18C show a servo feedback control circuit and its operation in using the vertical beam position reference mark in FIG. 18A to control the vertical beam position on the screen.

10 [0027] FIG. 19 shows an example of the screen in FIG. 11 having the start of line reference mark and the vertical beam position reference marks.

[0028] FIG. 20 shows an operation of the servo control based on the servo beam that is scanned with the excitation beam.

15 [0029] FIGS. 21, 22 and 23 show examples of screen designs that have IR servo feedback marks that do not affect the transmission amount of excitation beams while having a property of diffuse or specular reflection for at least the servo beams.

[0030] FIG. 24 shows an example of the screen design to have specularly reflective IR feedback marks and diffusively reflective areas outside the IR feedback marks on the screen.

[0031] FIG. 25 shows an example of a system based on the design in FIG. 24.

20 [0032] FIG. 26 shows an example of a system that combines IR servo feedback and visible light servo feedback.

[0033] FIGS. 27, 28, 29 and 30 illustrate aspects of the system in FIG. 26.

[0034] FIG. 31 shows a system implementation of the system in FIG. 26.

### Detailed Description

[0035] Examples of scanning beam display systems in this application use screens with light-emitting materials or fluorescent materials to emit light under optical excitation to produce images, including laser video display systems. Various examples of screen designs with light-emitting or fluorescent materials can be used. In one implementation, for example, three different color phosphors that are optically excitable by the laser beam to respectively produce light in red, green, and blue colors suitable for forming color images may be formed on the screen as pixel dots or repetitive red, green and blue phosphor stripes in parallel.

[0036] Phosphor materials are one type of fluorescent materials. Various described systems, devices and features in the examples that use phosphors as the fluorescent materials are applicable to displays with screens made of other optically excitable, light-emitting, non-phosphor fluorescent materials. For example, quantum dot materials emit light under proper optical excitation and thus can be used as the fluorescent materials for systems and devices in this application. More specifically, semiconductor compounds such as, among others, CdSe and PbS, can be fabricated in form of particles with a diameter on the order of the exciton Bohr radius of the compounds as quantum dot materials to emit light. To produce light of different colors, different quantum dot materials with different energy band gap structures may be used to emit different colors under the same excitation light. Some quantum dots are between 2 and 10 nanometers in size and include approximately tens of atoms such between 10 to 50 atoms. Quantum dots may be dispersed and mixed in various materials to form liquid solutions, powders, jelly-like matrix materials and solids (e.g., solid solutions).

Quantum dot films or film stripes may be formed on a substrate as a screen for a system or device in this application. In one implementation, for example, three different quantum dot materials can be designed and engineered to be optically excited by the scanning laser beam as the optical pump to produce light in red, green, and blue colors suitable for forming color images. Such quantum dots may be formed on the screen as pixel dots arranged in parallel lines (e.g., repetitive sequential red pixel dot line, green pixel dot line and blue pixel dot line).

[0037] Examples of scanning beam display systems described here use at least one scanning laser beam to excite color light-emitting materials deposited on a screen to produce color images. The scanning laser beam is modulated to carry images in red, green and blue colors or in other visible colors and is controlled in such a way that the laser beam excites the color light-emitting materials in red, green and blue colors with images in red, green and blue colors, respectively. Hence, the scanning laser beam carries the images but does not directly produce the visible light seen by a viewer. Instead, the color light-emitting fluorescent

materials on the screen absorb the energy of the scanning laser beam and emit visible light in red, green and blue or other colors to generate actual color images seen by the viewer.

**[0038]** Laser excitation of the fluorescent materials using one or more laser beams with energy sufficient to cause the fluorescent materials to emit light or to luminesce is one of various forms of optical excitation. In other implementations, the optical excitation may be generated by a non-laser light source that is sufficiently energetic to excite the fluorescent materials used in the screen. Examples of non-laser excitation light sources include various light-emitting diodes (LEDs), light lamps and other light sources that produce light at a wavelength or a spectral band to excite a fluorescent material that converts the light of a higher energy into light of lower energy in the visible range. The excitation optical beam that excites a fluorescent material on the screen can be at a frequency or in a spectral range that is higher in frequency than the frequency of the emitted visible light by the fluorescent material. Accordingly, the excitation optical beam may be in the violet spectral range and the ultra violet (UV) spectral range, e.g., wavelengths under 420 nm. In the examples described below, Violet or a UV laser beam is used as an example of the excitation light for a phosphor material or other fluorescent material and may be light at other wavelength.

**[0039]** FIG. 1 illustrates an example of a laser-based display system using a screen having color phosphor stripes. Alternatively, color pixilated light-emitting areas may also be used to define the image pixels on the screen. The system includes a laser module 110 to produce and project at least one scanning laser beam 120 onto a screen 101. The screen 101 has parallel color phosphor stripes in the vertical direction and two adjacent phosphor stripes are made of different phosphor materials that emit light in different colors. In the illustrated example, red phosphor absorbs the laser light to emit light in red, green phosphor absorbs the laser light to emit light in green and blue phosphor absorbs the laser light to emit light in blue. Adjacent three color phosphor stripes are in three different colors. One particular spatial color sequence of the stripes is shown in FIG. 1 as red, green and blue. Other color sequences may also be used. The laser beam 120 is at the wavelength within the optical absorption bandwidth of the color phosphors and is usually at a wavelength shorter than the visible blue and the green and red colors for the color images. As an example, the color phosphors may be phosphors that absorb UV light in the spectral range below 420 nm to produce desired red, green and blue light. The laser module 110 can include one or more lasers such as UV diode lasers to produce the beam 120, a beam scanning mechanism to scan the beam 120 horizontally and vertically to render one image frame at a time on the screen 101, and a signal modulation mechanism to modulate the beam 120 to carry the information

for image channels for red, green and blue colors. Such display systems may be configured as rear scanning systems where the viewer and the laser module 110 are on the opposite sides of the screen 101. Alternatively, such display systems may be configured as front scanning systems where the viewer and laser module 110 are on the same side of the screen 101.

**[0040]** Examples of implementations of various features, modules and components in the scanning laser display system in FIG. 1 are described in U.S. Patent Application No.

10/578,038 entitled "Display Systems and Devices Having Screens With Optical Fluorescent Materials" and filed on May 2, 2006 (U.S. Patent Publication No. \_\_\_\_\_), PCT

10 Patent Application No. PCT/US2007/004004 entitled "Servo-Assisted Scanning Beam Display Systems Using Fluorescent Screens" and filed on February 15, 2007 (PCT

Publication No. WO 2007/095329), PCT Patent Application No. PCT/US2007/068286

entitled "Phosphor Compositions For Scanning Beam Displays" and filed on May 4, 2007

(PCT Publication No. WO 2007/131195), PCT Patent Application No. PCT/US2007/68989

15 entitled "Multilayered Fluorescent Screens for Scanning Beam Display Systems" and filed on May 15, 2007 (PCT Publication No. WO 2007/134329), and PCT Patent Application No.

PCT/US2006/041584 entitled "Optical Designs for Scanning Beam Display Systems Using Fluorescent Screens" and filed on October 25, 2006 (PCT Publication No. WO

20 2007/050662). The disclosures of the above-referenced patent applications are incorporated by reference in their entirety as part of the specification of this application.

**[0041]** FIG. 2A shows an exemplary design of the screen 101 in FIG. 1. The screen 101 may include a rear substrate 201 which is transparent to the scanning laser beam 120 and faces the laser module 110 to receive the scanning laser beam 120. A second front substrate

202, is fixed relative to the rear substrate 201 and faces the viewer in a rear scanning configuration. A color phosphor stripe layer 203 is placed between the substrates 201 and

25 202 and includes phosphor stripes. The color phosphor stripes for emitting red, green and blue colors are represented by "R", "G" and "B," respectively. The front substrate 202 is transparent to the red, green and blue colors emitted by the phosphor stripes. The substrates

201 and 202 may be made of various materials, including glass or plastic panels. The rear

30 substrate 201 can be a thin film layer and is configured to recycle the visible energy toward the viewer. Each color pixel includes portions of three adjacent color phosphor stripes in the horizontal direction and its vertical dimension is defined by the beam spread of the laser

beam 120 in the vertical direction. As such, each color pixel includes three subpixels of three different colors (e.g., the red, green and blue). The laser module 110 scans the laser beam

120 one horizontal line at a time, e.g., from left to right and from top to bottom to fill the screen 101. The relative alignment of the laser module 110 and the screen 101 can be monitored and controlled to ensure proper alignment between the laser beam 120 and each pixel position on the screen 101. In one implementation, the laser module 110 can be controlled to be fixed in position relative to the screen 101 so that the scanning of the beam 120 can be controlled in a predetermined manner to ensure proper alignment between the laser beam 120 and each pixel position on the screen 101.

[0042] In FIG. 2A, the scanning laser beam 120 is directed at the green phosphor stripe within a pixel to produce green light for that pixel. FIG. 2B further shows the operation of the screen 101 in a view along the direction B-B perpendicular to the surface of the screen 101. Since each color stripe is longitudinal in shape, the cross section of the beam 120 may be shaped to be elongated along the direction of the stripe to maximize the fill factor of the beam within each color stripe for a pixel. This may be achieved by using a beam shaping optical element in the laser module 110. A laser source that is used to produce a scanning laser beam that excites a phosphor material on the screen may be a single mode laser or a multimode laser. The laser may also be a single mode along the direction perpendicular to the elongated direction phosphor stripes to have a beam spread that is confined by and is smaller than the width of each phosphor stripe. Along the elongated direction of the phosphor stripes, this laser beam may have multiple modes to spread over a larger area than the beam spread in the direction across the phosphor stripe. This use of a laser beam with a single mode in one direction to have a small beam footprint on the screen and multiple modes in the perpendicular direction to have a larger footprint on the screen allows the beam to be shaped to fit the elongated color subpixel on the screen and to provide sufficient laser power in the beam via the multimodes to ensure sufficient brightness of the screen.

[0043] Referring now to FIG. 3, an example implementation of the laser module 110 in FIG. 1 is illustrated. A laser array 310 with multiple lasers is used to generate multiple laser beams 312 to simultaneously scan the screen 101 for enhanced display brightness. A signal modulation controller 320 is provided to control and modulate the lasers in the laser array 310 so that the laser beams 312 are modulated to carry the image to be displayed on the screen 101. The signal modulation controller 320 can include a digital image processor that generates digital image signals for the three different color channels and laser driver circuits that produce laser control signals carrying the digital image signals. The laser control signals are then applied to modulate the lasers, e.g., the currents for laser diodes, in the laser array 310.

[0044] The beam scanning can be achieved by using a scanning mirror 340 such as a galvo mirror for the vertical scanning and a multi-facet polygon scanner 350 for the horizontal scanning. A scan lens 360 can be used to project the scanning beams from the polygon scanner 350 onto the screen 101. The scan lens 360 is designed to image each laser in the laser array 310 onto the screen 101. Each of the different reflective facets of the polygon scanner 350 simultaneously scans N horizontal lines where N is the number of lasers. In the illustrated example, the laser beams are first directed to the galvo mirror 340 and then from the galvo mirror 340 to the polygon scanner 350. The output scanning beams 120 are then projected onto the screen 101. A relay optics module 330 is placed in the optical path of the laser beams 312 to modify the spatial property of the laser beams 312 and to produce a closely packed bundle of beams 332 for scanning by the galvo mirror 340 and the polygon scanner 350 as the scanning beams 120 projected onto the screen 101 to excite the phosphors and to generate the images by colored light emitted by the phosphors. A relay optics module 370 is inserted between the scanners 340 and 350 to image the reflective surface of the reflector in the vertical scanner 340 into a respective reflecting facet of the polygon scanner 350 in order to prevent beam walk across the thin facet of the polygon scanner 350 in the vertical direction.

[0045] The laser beams 120 are scanned spatially across the screen 101 to hit different color pixels at different times. Accordingly, each of the modulated beams 120 carries the image signals for the red, green and blue colors for each pixel at different times and for different pixels at different times. Hence, the beams 120 are coded with image information for different pixels at different times by the signal modulation controller 320. The beam scanning thus maps the time-domain coded image signals in the beams 120 onto the spatial pixels on the screen 101. For example, the modulated laser beams 120 can have each color pixel time equally divided into three sequential time slots for the three color subpixels for the three different color channels. The modulation of the beams 120 may use pulse modulation techniques to produce desired grey scales in each color, a proper color combination in each pixel, and desired image brightness.

[0046] In one implementation, the multiple beams 120 are directed onto the screen 101 at different and adjacent vertical positions with two adjacent beams being spaced from each other on the screen 101 by one horizontal line of the screen 101 along the vertical direction. For a given position of the galvo mirror 340 and a given position of the polygon scanner 350, the beams 120 may not be aligned with each other along the vertical direction

on the screen 101 and may be at different positions on the screen 101 along the horizontal direction. The beams 120 can only cover one portion of the screen 101.

**[0047]** In one implementation, at an angular position of the galvo mirror 340, the spinning of the polygon scanner 350 causes the beams 120 from N lasers in the laser array 310 to scan one screen segment of N adjacent horizontal lines on the screen 101. The galvo mirror 340 tilts linearly to change its tilting angle at a given rate along a vertical direction from the top towards the bottom during the scanning by the polygon until the entire screen 101 is scanned to produce a full screen display. At the end of the galvo vertical angular scan range, the galvo retraces to its top position and the cycle is repeated in synchronization with the refresh rate of the display.

**[0048]** In another implementation, for a given position of the galvo mirror 340 and a given position of the polygon scanner 350, the beams 120 may not be aligned with each other along the vertical direction on the screen 101 and may be at different positions on the screen 101 along the horizontal direction. The beams 120 can only cover one portion of the screen 101. At a fixed angular position of the galvo mirror 340, the spinning of the polygon scanner 350 causes the beams 120 from N lasers in the laser array 310 to scan one screen segment of N adjacent horizontal lines on the screen 101. At the end of each horizontal scan over one screen segment, the galvo mirror 340 is adjusted to a different fixed angular position so that the vertical positions of all N beams 120 are adjusted to scan the next adjacent screen segment of N horizontal lines. This process iterates until the entire screen 101 is scanned to produce a full screen display.

**[0049]** In the above example of a scanning beam display system shown in FIG. 3, the scan lens 360 is located downstream from the beam scanning devices 340 and 350 and focuses the one or more scanning excitation beams 120 onto the screen 101. This optical configuration is referred to as a "pre-objective" scanning system. In such a pre-objective design, a scanning beam directed into the scan lens 360 is scanned along two orthogonal directions. Therefore, the scan lens 360 is designed to focus the scanning beam onto the screen 101 along two orthogonal directions. In order to achieve the proper focusing in both orthogonal directions, the scan lens 360 can be complex and, often, are made of multiples lens elements. In one implementation, for example, the scan lens 360 can be a two-dimensional f-theta lens that is designed to have a linear relation between the location of the focal spot on the screen and the input scan angle (theta) when the input beam is scanned around each of two orthogonal axes perpendicular to the optic axis of the scan lens. The two-dimensional scan lens 360 such as a f-theta lens in the pre-objective configuration can exhibit

optical distortions along the two orthogonal scanning directions which cause beam positions on the screen 101 to trace a curved line. The scan lens 360 can be designed with multiple lens elements to reduce the bow distortions and can be expensive to fabricate.

**[0050]** To avoid the above distortion issues associated with a two-dimensional scan lens in a pre-objective scanning beam system, a post-objective scanning beam display system can be implemented to replace the two-dimensional scan lens 360 with a simpler, less expensive 1-dimensional scan lens. U.S. Patent Application No. 11/742,014 entitled "POST-OBJECTIVE SCANNING BEAM SYSTEMS" and filed on April 30, 2007 (U.S. Patent Publication No. \_\_\_\_\_) describes examples of post-objective scanning beam systems suitable for use with phosphor screens described in this application and is incorporated by reference as part of the specification of this application.

**[0051]** FIG. 4 shows an example implementation of a post-objective scanning beam display system based on the system design in FIG. 1. A laser array 310 with multiple lasers is used to generate multiple laser beams 312 to simultaneously scan a screen 101 for enhanced display brightness. A signal modulation controller 320 is provided to control and modulate the lasers in the laser array 310 so that the laser beams 312 are modulated to carry the image to be displayed on the screen 101. The beam scanning is based on a two-scanner design with a horizontal scanner such as a polygon scanner 350 and a vertical scanner such as a galvanometer scanner 340. Each of the different reflective facets of the polygon scanner 350 simultaneously scans N horizontal lines where N is the number of lasers. A relay optics module 330 reduces the spacing of laser beams 312 to form a compact set of laser beams 332 that spread within the facet dimension of the polygon scanner 350 for the horizontal scanning. Downstream from the polygon scanner 350, there is a 1-D horizontal scan lens 380 followed by a vertical scanner 340 (e.g., a galvo mirror) that receives each horizontally scanned beam 332 from the polygon scanner 350 through the 1-D scan lens 380 and provides the vertical scan on each horizontally scanned beam 332 at the end of each horizontal scan prior to the next horizontal scan by the next facet of the polygon scanner 350. The vertical scanner 340 directs the 2-D scanning beams 390 to the screen 101.

**[0052]** Under this optical design of the horizontal and vertical scanning, the 1-D scan lens 380 is placed downstream from the polygon scanner 140 and upstream from the vertical scanner 340 to focus each horizontal scanned beam on the screen 101 and minimizes the horizontal bow distortion to displayed images on the screen 101 within an acceptable range, thus producing a visually "straight" horizontal scan line on the screen 101. Such a 1-D scan lens 380 capable of producing a straight horizontal scan line is relatively simpler and less

expensive than a 2-D scan lens of similar performance. Downstream from the scan lens 380, the vertical scanner 340 is a flat reflector and simply reflects the beam to the screen 101 and scans vertically to place each horizontally scanned beam at different vertical positions on the screen 101 for scanning different horizontal lines. The dimension of the reflector on the vertical scanner 340 along the horizontal direction is sufficiently large to cover the spatial extent of each scanning beam coming from the polygon scanner 350 and the scan lens 380. The system in FIG. 4 is a post-objective design because the 1-D scan lens 380 is upstream from the vertical scanner 340. In this particular example, there is no lens or other focusing element downstream from the vertical scanner 340.

**[0053]** Notably, in the post-objective system in FIG. 4, the distance from the scan lens to a location on the screen 101 for a particular beam varies with the vertical scanning position of the vertical scanner 340. Therefore, when the 1-D scan lens 380 is designed to have a fixed focal distance along the straight horizontal line across the center of the elongated 1-D scan lens, the focal properties of each beam must change with the vertical scanning position of the vertical scanner 380 to maintain consistent beam focusing on the screen 101. In this regard, a dynamic focusing mechanism can be implemented to adjust convergence of the beam going into the 1-D scan lens 380 based on the vertical scanning position of the vertical scanner 340.

**[0054]** For example, in the optical path of the one or more laser beams from the lasers to the polygon scanner 350, a stationary lens and a dynamic refocus lens can be used as the dynamic focusing mechanism. Each beam is focused by the dynamic focus lens at a location upstream from the stationary lens. When the focal point of the lens coincides with the focal point of the lens, the output light from the lens is collimated. Depending on the direction and amount of the deviation between the focal points of the lenses, the output light from the collimator lens toward the polygon scanner 350 can be either divergent or convergent. Hence, as the relative positions of the two lenses along their optic axis are adjusted, the focus of the scanned light on the screen 101 can be adjusted. A refocusing lens actuator can be used to adjust the relative position between the lenses in response to a control signal. In this particular example, the refocusing lens actuator is used to adjust the convergence of the beam directed into the 1-D scan lens 380 along the optical path from the polygon scanner 350 in synchronization with the vertical scanning of the vertical scanner 340. The vertical scanner 340 in FIG. 4 scans at a much smaller rate than the scan rate of the first horizontal scanner 350 and thus a focusing variation caused by the vertical scanning on the screen 101 varies with time at the slower vertical scanning rate. This allows a focusing adjustment mechanism

to be implemented in the system of FIG. 1 with the lower limit of a response speed at the slower vertical scanning rate rather than the high horizontal scanning rate.

[0055] The beams 120 on the screen 101 are located at different and adjacent vertical positions with two adjacent beams being spaced from each other on the screen 101 by one horizontal line of the screen 101 along the vertical direction. For a given position of the galvo mirror 540 and a given position of the polygon scanner 550, the beams 120 may not be aligned with each other along the vertical direction on the screen 101 and may be at different positions on the screen 101 along the horizontal direction. The beams 120 can cover one portion of the screen 101.

[0056] FIG. 5 illustrates the above simultaneous scanning of one screen segment with multiple scanning laser beams 120 at a time. Visually, the beams 120 behaves like a paint brush to “paint” one thick horizontal stroke across the screen 101 at a time to cover one screen segment between the start edge and the end edge of the image area of the screen 101 and then subsequently to “paint” another thick horizontal stroke to cover an adjacent vertically shifted screen segment. Assuming the laser array 310 has  $N=36$  lasers, a 1080-line progressive scan of the screen 101 would require scanning 30 vertical screen segments for a full scan. Hence, this configuration in an effect divides the screen 101 along the vertical direction into multiple screen segments so that the  $N$  scanning beams scan one screen segment at a time with each scanning beam scanning only one line in the screen segment and different beams scanning different sequential lines in that screen segment. After one screen segment is scanned, the  $N$  scanning beams are moved at the same time to scan the next adjacent screen segment.

[0057] In the above design with multiple laser beams, each scanning laser beam 120 scans only a number of lines across the entire screen along the vertical direction that is equal to the number of screen segments. Hence, the polygon scanner 550 for the horizontal scanning can operate at slower speeds than scanning speeds required for a single beam design where the single beam scans every line of the entire screen. For a given number of total horizontal lines on the screen (e.g., 1080 lines in HDTV), the number of screen segments decreases as the number of the lasers increases. Hence, with 36 lasers, the galvo mirror and the polygon scanner scan 30 lines per frame while a total of 108 lines per frame are scanned when there are only 10 lasers. Therefore, the use of the multiple lasers can increase the image brightness which is approximately proportional to the number of lasers used, and, at the same time, can also advantageously reduce the speed of the scanning system.

[0058] A scanning display system described in this specification can be calibrated during the manufacture process so that the laser beam on-off timing and position of the laser beam relative to the fluorescent stripes in the screen 101 are known and are controlled within a permissible tolerance margin in order for the system to properly operate with specified image quality. However, the screen 101 and components in the laser module 101 of the system can change over time due to various factors, such as scanning device jitter, changes in temperature or humidity, changes in orientation of the system relative to gravity, settling due to vibration, aging and others. Such changes can affect the positioning of the laser source relative to the screen 101 over time and thus the factory-set alignment can be altered due to such changes. Notably, such changes can produce visible and, often undesirable, effects on the displayed images. For example, a laser pulse in the scanning excitation beam 120 may hit a subpixel that is adjacent to an intended target subpixel for that laser pulse due to a misalignment of the scanning beam 120 relative to the screen along the horizontal scanning direction. When this occurs, the coloring of the displayed image is changed from the intended coloring of the image. Hence, a red pixel in the intended image may be displayed as a green pixel on the screen. For another example, a laser pulse in the scanning excitation beam 120 may hit both the intended target subpixel and an adjacent subpixel next to the intended target subpixel due to a misalignment of the scanning beam 120 relative to the screen along the horizontal scanning direction. When this occurs, the coloring of the displayed image is changed from the intended coloring of the image and the image resolution deteriorates. The visible effects of these changes can increase as the screen display resolution increases because a smaller pixel means a smaller tolerance for a change in position. In addition, as the size of the screen increases, the effect of a change that can affect the alignment can be more pronounced because a large moment arm in scanning each excitation beam 120 associated with a large screen means that an angular error can lead to a large position error on the screen. For example, if the laser beam position on the screen for a known beam angle changes over time, the result is a color shift in the image. This effect can be noticeable and thus undesirable to the viewer.

[0059] Implementations of various alignment mechanisms are provided in this specification to maintain proper alignment of the scanning beam 120 on the desired sub-pixel to achieved desired image quality. These alignment mechanisms include reference marks on the screen, both in the fluorescent area and in one or more peripheral area outside the fluorescent area, emitted visible light in red, green and blue colors by the phosphor stripes to provide feedback light that is caused by the excitation beam 120 and represents the position

and other properties of the scanning beam on the screen. The feedback light can be measured by using one or more optical servo sensors to produce one or more feedback servo signals and such feedback servo signals are used to generate a location map for red, green and blue sub-pixels on the screen. A servo control in the laser module 110 processes this feedback servo signal to extract the information on the beam positioning and other properties of the beam on the screen and, in response, adjust the direction and other properties of the scanning beam 120 to ensure the proper operation of the display system.

[0060] For example, a feedback servo control system can be provided to use peripheral servo reference marks positioned outside the display area unobservable by the viewer to provide control over various beam properties, such as the horizontal positioning along the horizontal scanning direction perpendicular to the fluorescent stripes, the vertical positioning along the longitudinal direction of the fluorescent stripes, the beam focusing on the screen for control of image color (e.g., color saturation) and image sharpness, and the beam power on the screen for control of image brightness and uniformity of the image brightness across the screen. For another example, a screen calibration procedure can be performed at the startup of the display system to measure the beam position information as a calibration map so having the exact positions of sub-pixels on the screen in the time domain. This calibration map is then used by the laser module 110 to control the timing and positioning of the scanning beam 120 to achieve the desired color purity. For yet another example, a dynamic servo control system can be provided to regularly update the calibration map during the normal operation of the display system by using servo reference marks in the fluorescent area of the screen to provide the feedback light without affecting the viewing experience of a viewer. Examples for using servo light produced by phosphor stripe dividers from the excitation light and feedback light from other reference marks for servo control and screen calibration are described in the incorporated-by-reference PCT Patent Application No. PCT/US2007/004004 entitled "Servo-Assisted Scanning Beam Display Systems Using Fluorescent Screens" (PCT Publication No. WO 2007/095329).

[0061] The display systems in this application provide servo control mechanisms based on a designated servo beam that is scanned over the screen by the same scanning module that scans the image-carrying excitation optical beam. This designated servo beam is used to provide servo feedback control over the scanning excitation beam to ensure proper optical alignment and accurate delivery of optical pulses in the excitation beam during normal display operation. This designated servo beam has an optical wavelength different from that of the excitation beam. As an example, this designated servo beam can be an IR servo beam

that may be invisible to human. The examples below use an IR servo beam 130 to illustrate features and operations of this designated servo beam.

[0062] Referring to FIG. 1, the laser module 110 produces an invisible servo beam 130 such as an IR beam as an example of the designated servo beam. The laser module 110 scans the servo beam 130 on to the screen 101 along with the excitation beam 120. Different from the excitation beam 120, the servo beam 130 is not modulated to carry image data. The servo beam 130 can be a CW beam. The stripe dividers on the screen 101 can be made reflective to the light of the servo beam 130 and to produce feedback light 132 by reflection. The servo beam 130 has a known spatial relation with the excitation beam 120. Therefore, the positioning of the servo beam 130 can be used to determine the positioning of the excitation beam 120. This relationship between the servo beam 130 and the excitation beam 120 can be determined by using reference servo marks such as a start of line (SOL) mark in a non-viewing area of the screen 101. The laser module 101 receives and detects the feedback light 132 to obtain positioning information of the servo beam 130 on the screen 101 and uses this positioning information to control alignment of the excitation beam 120 on the screen.

[0063] The servo beam 130 is invisible to human and thus does not produce any noticeable visual artifact on the screen 101 during the normal operation of the system when images are produced on the screen 101. For example, the servo beam 130 can have a wavelength in a range from 780 nm to 820 nm. For safety concerns, the screen 101 can be made to have a filter that blocks the invisible servo beam 130 from exiting the screen 101 on the viewer side. In this regard, a cutoff absorbing filter with a bandpass transmission range only in the visible spectral range (e.g., from 420 nm to 680 nm) may be used to block the servo beam 130 and excitation beam 120. The servo control of the excitation beam 120 based on the servo beam 130 can be performed dynamically during the normal operation of the system. This servo design avoids manipulation of the image-producing excitation beam 120 during the normal display mode for servo operations and thus avoids any visual artifacts that may be caused by the servo-related manipulation of the image-producing excitation beam 120.

[0064] In addition, the scattered or reflected excitation light by the screen 101 may also be used for servo control operations during a period when the system does not show images, e.g., during the startup period of the system or when the excitation beam 120 is outside the active display area of the screen 101. In such a case, the scattered or reflected excitation light, labeled as light 122, can be used as servo feedback light for servo control of, e.g., the horizontal alignment or the vertical alignment of each laser beam 120.

[0065] In the examples of the systems in FIGS. 3 and 4, the servo beam 130 is directed along with the one or more excitation beams 120 through the same optical path that includes the relay optics module 330A or 330B, the beam scanners 340 and 350, and the scan lens 360 or 380. Referring to FIG. 5, the servo beam 130 is scanned along with the scanning

5 excitation beams 120 one screen segment at a time along the vertical direction of the screen. The servo beam 130 is invisible and can be overlapped with a scanning path of one excitation beam 120 or along its own scanning path that is different from a path of any of the excitation beams 120. The spatial relation between the servo beam 130 and each excitation beam 120 is known and fixed so that the positioning of the servo beam 130 on the screen 101 can be used  
10 to infer positioning of each excitation beam 120.

[0066] A light source for generating the servo beam 130 and a light source for generating an excitation beam 120 can be semiconductor lasers in a light source module which can be an array of lasers and at least one of the lasers in the laser array can be a servo  
15 laser that produces the servo beam 130. In one implementation, the location of the servo laser is known relative to each excitation laser in the laser array in the laser module 110. The servo beam 130 and each excitation beam 120 are directed through the same relay optics, the same beam scanners and the same projection lens and are projected on the screen 101.

Therefore, the positioning of the servo beam 130 on the screen 101 has a known relation with the positioning of each excitation beam 120 on the screen. This relation between the servo  
20 beam 130 and each excitation beam 120 can be used to control the excitation beam 120 based on measured positioning of the servo beam 130. The relative position relation between the servo beam 130 and each excitation beam 120 can be measured using the servo feedback, e.g., during a calibration process that may be separately performed or performed during the power-up period of the system. The measured relative position relation is used for the servo  
25 feedback control.

[0067] FIG. 5A shows a map of beam positions on the screen produced by a laser array of thirty-six excitation lasers and one IR servo laser when a vertical galvo scanner and a horizontal polygon scanner are at their respective null positions in a prototype pre-objective scanning display system. The thirty-six excitation lasers are arranged in a 4x9 laser array and  
30 the IR servo laser is placed in the center of the laser array. The laser beams occupy an area of about 20 mm x 25mm on the screen. In this example, the vertical spacing is one half of a pixel between two vertically adjacent excitation lasers and the horizontal spacing between two adjacent excitation lasers is 3.54 pixels. Because the excitation lasers are spatially staggered along both horizontal and vertical directions, each scan in one screen segment

produces thirty-six horizontal lines on the screen occupying thirty-six pixels along the vertical direction. In operation, these thirty-seven laser beams are scanned together based on the scanning shown in FIG. 5 to scan one screen segment at a time to sequentially scan different screen segments at different vertical positions to scan the entire screen. Because the IR servo laser is fixed in position with respect to each and every one of the thirty-six excitation lasers, the positioning of the servo beam 130 produced by the IR servo laser on the screen 101 has a known relation with respect to each beam spot of an excitation beam 120 from each of the thirty-six excitation lasers.

[0068] FIG. 6 illustrates a scanning beam display system based on a servo control using the invisible servo beam 130. A display processor and controller 640 can be used to provide control functions and control intelligence based on servo detector signals from radiation servo detectors 620 that detect servo feedback light 132 from the screen 101. A single detector 620 may be sufficient and two or more servo detectors 620 can be used to improve the servo detection sensitivity.

[0069] Similarly, one or more radiation servo detectors 630 may also be used to collect excitation servo light 122 produced by scattering or reflecting the excitation beam 120 at the screen to provide additional feedback signals to the processor and controller 640 for the servo control. This use of the servo light 122 for feedback control can be an optional feature that is used in combination with the IR servo feedback control. In some system implementations, the IR servo feedback alone without the feedback based on the feedback light 122 shown in FIG. 6 can be sufficient to align the excitation beam 120 to the proper phosphor stripes on the screen 101. Examples for using the servo light 122 produced by phosphor stripe dividers for servo control are described in the incorporated-by-reference PCT Patent Application No. PCT/US2007/004004 entitled "Servo-Assisted Scanning Beam Display Systems Using Fluorescent Screens" (PCT Publication No. WO 2007/095329).

[0070] In FIG. 6, a scanning projection module 610 is provided to scan and project the excitation and servo beams 120 and 130 onto the screen 101. The module 610 can be in a post-objective configuration or a pre-objective configuration. As illustrated, the image data is fed to the display processor and controller 640 which produces an image data signal carrying the image data to the signal modulator controller 520 for the excitation lasers 510. The servo laser which is among the excitation lasers in the array 510 is not modulated to carry image data. The signal modulation controller 520 can include laser driver circuits that produce laser modulation signals carrying image signals with image data assigned to different lasers 510, respectively. The laser control signals are then applied to modulate the lasers in the laser

array 510, e.g., the currents for laser diodes to produce the laser beams 512. The display processor and controller 640 also produces laser control signals to the lasers in the laser array 510 to adjust the laser orientation to change the vertical beam position on the screen 101 or the DC power level of each laser. The display processor and controller 5930 further produces scanning control signals to the scanning projection module 610 to control and synchronize the horizontal polygon scanner and the vertical scanner.

[0071] FIG. 7 shows one example of the servo detector design where a servo detector 620 detects the servo feedback light 132. The servo detector 620 can be a detector designed to be sensitive to light of the servo beam wavelength for the invisible servo beam 130 and less sensitive to other light such as the visible light and the excitation light. An optical filter 710 can be used to filter the light from the screen 101 to selectively transmit the servo feedback light 132 while blocking light at other wavelengths, such as the excitation light and visible light. Such a filter allows a wider range of optical detectors to be used as the servo detector. FIG. 7 also shows an example of an optional servo detector 630 for detecting the servo feedback light 122 at the excitation wavelength. The servo detector 620 can be a detector designed to be sensitive to light of the excitation wavelength of the excitation beam 120 and less sensitive to light at wavelengths of the servo beam 130 and the visible light emitted by the screen 101. An optical filter 720 can be used to filter the light from the screen 101 to selectively transmit the excitation servo feedback light 122 while blocking light at other wavelengths. The servo detector signals 721 and 722 from the servo detectors 620 and 630, respectively, are directed to the processor and controller 640 for servo control operations.

[0072] FIGS. 8 and 9 show two exemplary screen designs for the screen 101 for providing the feedback light 122 and 132. In FIG. 8, each strip divider 810 is made optically reflective to the servo and excitation beams so the reflection can be used as the feedback light 132. The strip divider 810 can also be made reflective and opaque to light to optically isolate adjacent light-emitting stripes to enhance contrast and to reduce cross talk. The light-emitting stripes such as phosphor stripes emitting red, green and blue light are less reflective to the servo and excitation beams than the stripe dividers 810 so that the feedback light 132 exhibits a spike every time the servo or excitation beams 130 pass through a stripe divider 810. An absorbent black layer 820 can be coated on each stripe divider on the viewer side to reduce glare of ambient light to the viewer. FIG. 9 shows another screen design where a reflective servo reference mark 910 is formed on the excitation side of each stripe divider 901, e.g., a reflective stripe coating.

[0073] In each horizontal scan, the beam 120 or 130 scans across the light-emitting stripes and the reflections produced by the stripe dividers can be used to indicate horizontal positions of the stripe dividers, spacing between two adjacent stripe dividers and horizontal positions of the horizontally scanned beam 120 or 130. Therefore, reflections from the stripe dividers can be used for servo control of the horizontal alignment between the beam 120 and the light-emitting strips.

[0074] FIG. 10 shows operation of the stripe dividers as alignment reference marks. As the servo beam 120 or 130 is scanned horizontally across the screen 101 and the light at the servo beam shows a low power when the servo beam 130 is at a light-emitting stripe and a high power when the servo beam is at a stripe divider. When the beam spot of the servo beam 130 on the screen 101 is less than the width of one subpixel, the power of the servo light shows a periodic pattern in each horizontal scan where the high power peak corresponds to a stripe divider. This pattern can be used to measure the position of the stripe dividers or the width of each stripe divider based on clock cycles of a clocking signal in the processor and controller 640. This measured information is used to update a positioning map of each excitation beam 120 in the horizontal scan. When the beam spot of the servo beam 130 is greater than one width of the subpixel but is less than one color pixel made up by three adjacent subpixels, the power of the servo light 132 still shows a periodic pattern in each horizontal scan where the high power peak corresponds to one color pixel and thus can be used for servo control.

[0075] In addition to the stripe dividers as alignment reference marks on the screen 101, additional alignment reference marks can be implemented to determine the relative position of the beam and the screen and other parameters of the excitation beam on the screen. For example, during a horizontal scan of the excitation and servo beams across the light-emitting stripes, a start of line mark can be provided for the system to determine the beginning of the active light-emitting display area of the screen 101 so that the signal modulation controller of the system can properly control the timing in delivering optical pulses to targeted pixels. An end of line mark can also be provided for the system to determine the end of the active light-emitting display area of the screen 101 during a horizontal scan. For another example, a vertical alignment referenced mark can be provided for the system to determine whether the scanning beams are pointed to a proper vertical location on the screen. Other examples for reference marks may be one or more reference marks for measuring the beam spot size on the screen and one or more reference marks on the screen to measure the optical power of the excitation beam 120. Such reference marks can be placed a region outside the active

fluorescent area of the screen 101, e.g., in one or more peripheral regions of the active fluorescent screen area and are used for both excitation and servo beams.

[0076] FIG. 11 illustrates one example of a fluorescent screen 101 having peripheral reference mark regions. The screen 101 includes a central active light-emitting display area 1100 with parallel fluorescent stripes for displaying images, two stripe peripheral reference mark regions 1110 and 1120 that are parallel to the fluorescent stripes. Each peripheral reference mark region can be used to provide various reference marks for the screen 101. In some implementations, only the left peripheral reference mark region 1110 is provided without the second region 1120 when the horizontal scan across the fluorescent stripes is directed from the left to the right of the area 1100.

[0077] Such a peripheral reference mark region on the screen 101 allows the scanning display system to monitor certain operating parameters of the system. A reference mark in the peripheral reference mark region can be used for a servo control operation based on the servo feedback light 132 generated from the servo beam 130. When the servo feedback light 122 generated from the excitation beam 120 is also used for a servo control operation, a reference mark in the peripheral reference mark region can be used for servo control operation based on the servo feedback light 122. A reference mark in the peripheral reference mark region can be used to measure both the excitation beam 120 and the servo beam 130 for a servo control operation in some implementations. The description on various examples of reference marks below may specifically refer to the excitation beam 120 and similar functions can be used in connection with the servo beam 130.

[0078] Notably, a reference mark in the peripheral reference mark region is outside the active display area 1100 of the screen 101 and thus a corresponding servo feedback control function can be performed outside the duration during the display operation when the excitation beam is scanning through the active fluorescent display area 2600 to display image. Therefore, a dynamic servo operation can be implemented without interfering with the display of the images to the viewer. In this regard, each scan can include a continuous mode period when an excitation beam scans through the peripheral referenced mark region for the dynamic servo sensing and control and a display mode period when the modulation of the excitation beam is turned on to produce image-carrying optical pulses as the excitation beam scans through the active fluorescent display area 1100. The servo beam 130 is not modulated to carry image data and thus can be a continuous beam with a constant beam power when incident onto the screen 101. The power of the reflected servo light in the feedback light 132 is modulated by the reference marks and stripe dividers and other screen pattern on the screen

101. The modulated power of the reflected servo light can be used to measure the location of the servo beam 130 on the screen 101.

[0079] FIG. 12 shows an example of a start of line (SOL) reference mark 1210 in the left peripheral region 1110 in the screen 101. The SOL reference mark 1210 can be an optically reflective, diffusive or fluorescent stripe parallel to the fluorescent stripes in the active light-emitting region 1100 of the screen 101. The SOL reference mark 1210 is fixed at a position with a known distance from the first fluorescent stripe in the region 1100. SOL patterns may be a single reflective stripe in some implementations and may include multiple vertical lines with uniform or variable spacing in other implementations. Multiple lines are selected for redundancy, increasing the signal to noise ratio, accuracy of position (time) measurement, and providing missing pulse detection.

[0080] In operation, the scanning excitation beam 120 is scanned from the left to the right in the screen 101 by first scanning through the peripheral reference mark region 1110 and then through the active region 1100. When the beam 120 is in the peripheral reference mark region 1110, the signal modulation controller in the laser module 110 of the system sets the beam 120 in a mode that ensures adequate sampling of information without crosstalk (e.g. one beam at a time during one frame) When the scanning excitation beam 120 scans through the SOL reference mark 1210, the light reflected, scattered or emitted by the SOL reference mark 1210 due to the illumination by the excitation beam 1210 can be measured at an SOL optical detector located near the SOL reference mark 1210. The presence of this signal indicates the location of the beam 120. The SOL optical detector can be fixed at a location in the region 1110 on the screen 101 or off the screen 101. Therefore, the SOL reference mark 1210 can be used to allow for periodic alignment adjustment during the lifetime of the system.

[0081] When the pulse from the SOL 1210 detected is detected for a given excitation beam, the laser can be controlled to, after the delay representing the time for scanning the beam from the SOL 1210 to the left edge of the active display area 1100, operate in the image mode and carry optical pulses with imaging data. The system then recalls a previously measured value for the delay from SOL pulse to beginning of the image area 1100. This process can be implemented in each horizontal scan to ensure that each horizontal line starts the image area properly and optical pulses in each horizontal scan are aligned to the light-emitting stripes. The correction is made prior to painting the image for that line in the area 1100 on the screen 101, so there is no time lag in displaying the images caused by the servo

control. This allows for both high frequency (up to line scan rate) and low frequency errors to be corrected.

[0082] The servo beam 130 can be used to provide a positioning reference for each excitation beam 120 for controlling both the timing for beginning image-carrying pulses before the excitation beam enters the active light-emitting area 1100 and during the normal display when the excitation beam 120 scans in the active light-emitting region 1100. FIG. 13 illustrates the detected signal power of the light at the servo beam wavelength in the feedback light 132 to show optical signals indicative of positions of the SOL mark and stripe dividers on the screen 101. The optical peaks in the feedback light shown in FIGS. 13 and 14 are idealized as sharp square wave signals and are likely to have tailing and leading profiles shown in FIGS. 15-16. Such a pulse signal with trailing and leading profiles can be converted into square wave like pulse signals by edge detection.

[0083] Similar to the SOL mark 1210, an end-of-line (EOL) reference mark can be implemented on the opposite side of the screen 101, e.g., in the peripheral reference mark region 1120 in FIG. 11. The SOL mark is used to ensure the proper alignment of the laser beam with the beginning of the image area. This does not ensure the proper alignment during the entire horizontal scan because the position errors can be present across the screen.

Implementing the EOL reference mark and an end-of-line optical detector in the region 1120 can be used to provide a linear, two point correction of laser beam position across the image area. FIG. 14 illustrates the detected signal power of the light at the servo beam wavelength in the feedback light 132 to show optical signals indicative of positions of the SOL mark, stripe dividers and EOL mark on the screen 101

[0084] When both SOL and EOL marks are implemented, the laser is turned on continuously in a continuous wave (CW) mode prior to reaching the EOL sensor area. Once the EOL signal is detected, the laser can be returned to image mode and timing (or scan speed) correction calculations are made based on the time difference between the SOL and EOL pulses. These corrections are applied to the next one or more lines. Multiple lines of SOL to EOL time measurements can be averaged to reduce noise.

[0085] Based on the stripe divider and SOL/EOL peripheral reference marks, the positioning of the servo beam 130 on the screen 101 can be measured. Because the servo beam 130 has a fixed relation with each excitation beam 120, which can be measured at the SOL reference mark or EOL reference mark, any error in the positioning of the servo beam 130 suggests a corresponding error in each excitation beam 120. Therefore, the positioning

information of the servo beam 130 can be used in the servo control to control the servo beam 130 and each excitation beam 120 to reduce an alignment error of the excitation beam.

**[0086]** The present servo control operates to place each optical pulse in the excitation beam 120 near or at the center of a target light-emitting stripe to excite the light-emitting

5 material in that stripe without spilling over to an adjacent light-emitting stripe. The servo control can be designed to achieve such alignment control by controlling the timing of each optical pulse in order to place the pulse at a desired position on the screen 101 during a horizontal scan. Accordingly, the servo control, i.e., the processor and controller 640, needs to “know” horizontal positions of the light-emitting stripes in each horizontal line before each

10 horizontal scan in order to control the timing of optical pulses during the scan. This information on horizontal positions of the light-emitting stripes in each horizontal line constitutes a two-dimensional position “map” of the active display area or light-emitting area of the screen 101 of (x, y ) coordinates where x is the horizontal position of each stripe divider (or equivalently, the horizontal position of the center of each stripe) and y is the

15 vertical position or ID number of a horizontal scan. This position map of the screen 101 can be measured at the factory and may change in time due to changes in the system components due to temperature, aging and other factors. For example, thermal expansion effects, and distortions in the optical imaging system will need corresponding adjustments in the precise timing to activate each color in a pixel. If the laser actuation does not properly correspond to

20 the timing where the beam is directed at the central portion of a sub-pixel or stripe for the intended phosphor, the beam 120 will either partially or completely activate the wrong color phosphor. In addition, this position map of the screen 101 can vary from one system to another due to the component and device tolerances during the manufacturing.

**[0087]** Therefore, it is desirable to update the position map of the screen 101 and to use the updated position map for controlling the timing of pulses of the excitation beam 120 in

25 each horizontal scan during the normal display. The position map of the screen 101 can be obtained using the feedback light 122 and 132 in a calibration scanning when the system is not in the normal display mode, e.g., during the start-up phase of the system. In addition, the servo feedback light 132 can be used in real time video display to monitor and measure

30 changes in an existing position map of the screen 101 when the system is operating in the normal display mode to produce images on the screen 101. This mode of the servo control is referred to as dynamic servo. The dynamic monitoring of the screen 101 can be useful when the system operates for an extended period time without a downtime because the screen 101

may undergo changes that can lead to significant changes to the position map of the screen 101 that is updated during the start-up phase of the system.

[0088] The position map of the screen 101 can be stored in the memory of the laser module 110 and reused for an interval of time if the effects that are being compensated for do not change significantly. In one implementation, when the display system is turned on, the display system can be configured to, as a default, set the timing of the laser pulses of the scanning laser beam based on the data in the stored position map. The servo control can operate to provide the real-time monitoring using the servo feedback light 132 and to control the pulse timing during the operation.

[0089] In another implementation, when the display system is turned on, the display system can be configured to, as a default, to perform a calibration using the excitation beam 120 and the servo beam 130 to scan through the entire screen 101. The measured position data are used to update the position map of the screen 101. After this initial calibration during the start-up phase, the system can be switched into the normal display mode and, subsequently during the normal display operation, only the servo beam 130 is used to monitor the screen 101 and the data on the screen 101 obtained from the servo beam 130 can be used to dynamically update the position map and thus to control the timing of pulses in the beam 120 in each horizontal scan.

[0090] The calibration of the position map of the screen 101 can be obtained by operating each scanning beam 120 or 130 in a continuous wave (CW) mode for one frame during which the scanning laser beams 120 and 130 simultaneously scan through the entire screen, one segment at a time as shown in FIG. 5, when multiple laser beams 120 are used. If a single laser is used to produce one excitation beam 120, the single scanning beam 120 is set in the CW mode to scan the entire screen 101, one line at a time, along with the servo beam 130.

The feedback light 122 and 132 from the servo reference marks on the stripe dividers is used to measure the laser position on the screen 101 by using the servo detectors 620 and 630.

[0091] The servo detector signals from the servo detectors 620 and 630 can be sent through an electronic "peak" detector that creates an electronic pulse whenever a servo signal is at its highest relative amplitude. The time between these pulses can be measured by a sampling clock in a digital circuit or microcontroller that is used by the processor and controller 640 to process and generate an error signal for controlling timing of optical pulses in each excitation beam 120 in a horizontal scan.

[0092] In one implementation, the time between two adjacent pulses from the electronic peak detector can be used to determine the spacing of the two locations that produce the two

adjacent electronic pulses based on the scan speed of the scanning beam 120 or 130 on the screen 101. This spacing can be used to determine the subpixel width and subpixel position.

**[0093]** In another implementation, servo measurements and corrections are based on

relative time measurements. Depending on the beam scan rate and the frequency of the

5 sampling clock, there are some nominal number of clocks for each sub-pixel. Due to optical distortions, screen defects or combination of the distortions and defects, the number of clock cycles between two adjacent pulses for any given sub-pixel may vary from the nominal number of clock cycles. This variation in clock cycles can be encoded and stored in memory for each sub-pixel. Alternatively, a correction value can be calculated and used for some  
10 number N of adjacent sub-pixels because changes usually do not occur with significant changes between adjacent sub-pixels.

**[0094]** FIG. 15 shows one example of the detected reflected feedback light as a function of the scan time for a portion of one horizontal scan, the respective output of the peak

detector and the sampling clock signal. A nominal subpixel with a width corresponding to 9

15 clock cycles of the sampling clock and an adjacent short subpixel corresponding to 8 clock cycles are illustrated. In some implementations, the width of a subpixel may correspond to

10-20 clock cycles. The clock cycle of the sampling clock signal of the digital circuit or microcontroller for the servo control dictates the spatial resolution of the error signal. As an

example for techniques to improve this spatial resolution, averaging over many frames can be

20 utilized to effectively increase the spatial resolution of the error signal.

**[0095]** FIG. 16 shows one example of the detected reflected feedback light as a function of the scan time for a portion of one horizontal scan, the respective output of the peak

detector and the sampling clock signal where a nominal subpixel corresponding to a width of 9 clock cycles and an adjacent long subpixel a corresponding to a width of 10 clock cycles re

25 illustrated.

**[0096]** During calibration, contaminants such as dust on the screen, screen defects, or some other factors may cause missing of an optical pulse in the reflected feedback light that would have been generated by a servo reference mark between two adjacent subpixels on the screen 101. FIG. 17 illustrates an example where a pulse is missing. A missing pulse can be

30 determined if a pulse is not sampled or detected within the nominal number of clock cycles for a subpixel within the maximum expected deviation from the nominal number of clocks for a subpixel. If a pulse is missed, the nominal value of clock cycles for a subpixel can be assumed for that missing sub-pixel and the next sub-pixel can contain the timing correction for both sub-pixels. The timing correction can be averaged over both sub-pixels to improve

the detection accuracy. This method may be extended for any number of consecutive missed pulses.

[0097] The above use of the sampling clock signal to measure the position map of the screen 101 can be used with detection with the excitation servo feedback light 122 or the servo feedback light 132 from the screen 101. Because the excitation beam or beams 120 scan all horizontal lines in the screen 101 during a calibration scan in a CW mode, the position data from the excitation servo feedback light 122 can provide data for each and every subpixel of the screen 101. The position data obtained from the servo beam 130 and its corresponding feedback light 132, however, only covers one horizontal scan line per screen segment as shown in FIG. 5. The position data measured from the servo beam 130 for one screen segment can be used as a representative scan for all horizontal lines in that screen segment is used to update position data for all lines in that screen segment. Two or more servo beams 130 may be used to increase the number of lines measured in each screen segment.

[0098] Vertical position of each laser can be monitored and adjusted by using an actuator, a vertical scanner, an adjustable lens in the optical path of each laser beam or a combination of these and other mechanisms. Vertical reference marks can be provided on the screen to allow for a vertical servo feedback from the screen to the laser module. One or more reflective, fluorescent or transmissive vertical reference marks can be provided adjacent to the image area of the screen 101 to measure the vertical position of each excitation beam 120. Referring to FIG. 11, such vertical reference marks can be placed in a peripheral reference mark region. One or more vertical mark optical detectors can be used to measure the reflected, fluorescent or transmitted light from a vertical reference mark when illuminated by the beam 120 or 130. The output of each vertical mark optical detector is processed and the information on the beam vertical position is used to control an actuator to adjust the vertical beam position on the screen 101.

[0099] FIG. 18A shows an example of a vertical reference mark 2810. The mark 2810 includes is a pair of identical triangle reference marks 2811 and 2812 that are separated and spaced from each other in both vertical and horizontal directions to maintain an overlap along the horizontal direction. Each triangle reference mark 2811 or 2812 is oriented to create a variation in the area along the vertical direction so that the beam 120 partially overlaps with each mark when scanning through the mark along the horizontal direction. As the vertical position of the beam 120 changes, the overlapping area on the mark with the beam 120 changes in size. The relative positions of the two marks 2811 and 2812 defines a

predetermined vertical beam position and the scanning beam along a horizontal line across this predetermined vertical position scans through the equal areas as indicated by the shadowed areas in the two marks 2811 and 2812. When the beam position is above this predetermined vertical beam position, the beam sees a bigger mark area in the first mark 2811  
5 than the mark area in the second mark 2812 and this difference in the mark areas seen by the beam increases as the beam position moves further up along the vertical direction.

Conversely, when the beam position is below this predetermined vertical beam position, the beam sees a bigger mark area in the second mark 2812 than the mark area in the first mark 2811 and this difference in the mark areas seen by the beam increases as the beam position  
10 moves further down along the vertical direction.

**[00100]** The feedback light from each triangle mark is integrated over the mark and the integrated signals of the two marks are compared to produce a differential signal. The sign of the differential signal indicated the direction of the offset from the predetermined vertical beam position and the magnitude of the differential signal indicates the amount of the offset.

15 The excitation beam is at the proper vertical position when the integrated light from each triangle is equal, i.e., the differential signal is zero.

**[00101]** FIG. 18B shows a portion of the signal processing circuit as part of the vertical beam position servo feedback control in the laser module 110 for the vertical reference mark in FIG. 18A. A PIN diode preamplifier 2910 receives and amplifies the differential signal for  
20 the two reflected signals from the two marks 2811 and 2812 and directs the amplified differential signal to an integrator 2920. An analog-to-digital converter 2930 is provided to convert the differential signal into a digital signal. A digital processor 2940 processes the differential signal to determine the amount and direction of the adjustment in the vertical beam position and accordingly produces a vertical actuator control signal. This control signal  
25 is converted into an analog control signal by a digital to analog converter 2950 and is applied to a vertical actuator controller 2960 which adjusts the actuator. FIG. 18C further shows generation of the differential signal by using a single optical detector.

**[00102]** FIG. 19 shows an example of the screen in FIG. 11 having the start of line (SOL) reference mark and the vertical beam position reference marks. Multiple vertical beam  
30 position reference marks can be placed at different vertical positions to provide vertical position sensing of the excitation beams 120 in all screen segments. The example in FIG. 19 shows the SOL reference mark is located between the vertical beam position reference marks and the screen display area so that, in a horizontal scan beginning from the left to the right, the excitation beam 120 or the servo beam 130 hits the SOL reference mark after the vertical

beam position reference marks. In another implementation for a horizontal scan beginning from the left to the right, the SOL reference mark is located between the vertical beam position reference marks and the screen display area to ensure that the excitation beam 120 or the servo beam 130 hits the SOL reference mark before the vertical beam position reference marks. In addition, separate from the vertical beam position reference marks for the excitation beams 120, multiple vertical beam position reference marks can be placed at different vertical positions, e.g., one vertical reference mark for the servo beam 130 to provide vertical position sensing of the servo beam 130 in each screen segment. These vertical reference marks are presented by the numeral "1910" in FIG. 19. The combination of the SOL reference 1210, the vertical reference marks 1910 and the periodic pattern in the strip structure of the light-emitting area 1110 provides positioning information of the invisible servo beam 130, positioning information of the excitation beams 120 and the horizontal parameters of the pixels on the screen 101 for servo control in a scanning display system.

**[00103]** FIG. 20 shows an example of the operation of a servo control using the servo beam 130 during the normal display mode when each excitation beam 120 is used for carrying optical pulses for producing images on the screen 101 and is not used for servo control. The servo beam 130 is a CW beam and is scanned over one horizontal line per screen segment with the scanning modulated excitation Laser beams 120. The servo feedback light 132 is detected by the one or more servo detectors 620 to measure an alignment error of the servo beam 130 on the screen 101 during the normal display. The alignment of each excitation laser beam 120 is adjusted based on the measured alignment error of the servo beam 130 to reduce the alignment error of the excitation laser beam 120. In other implementations, the red, green and blue light emitted by the screen 101 or a portion of back-reflected excitation light of the scanning excitation beam 120 can be used to provide a calibration mechanism to calibrate the measurements obtained via the servo beam 130.

**[00104]** In the above examples for using the invisible IR servo beam 130 to provide the feedback light 132 to the laser module 110, the parallel phosphor stripes and the stripe dividers on the screen 101 are used to produce back-reflected feedback light 132 by reflection of the servo beam 132 at the stripe dividers. Alternatively, the screen 101 can be designed to include IR feedback marks that are configured to produce desired feedback light 132. The IR feedback marks can be registered with a special spatial relationship with respect to the stripe dividers or the phosphor stripes, e.g., a servo feedback mark is aligned in position with a light-emitting stripe or a division (a divider) between two adjacent parallel light-emitting

stripes in the screen. In the examples described below, such position registration is not required and it is sufficient that the IR feedback marks have a fixed and known spatial relationship with respect to the stripe dividers or the phosphor stripes so that there is a fixed and known mapping of the positions of the IR feedback marks and the positions of the phosphor stripes and stripe dividers.

**[00105]** FIG. 21 shows an example design for the light-emitting screen 101 that includes IR feedback marks on the excitation side of the phosphor layer. This screen 101 includes a phosphor stripe layer 2110 with parallel phosphor stripes emitting red, green and blue light under excitation of the excitation beam 120, a back panel 2112 on the excitation side of the phosphor layer 2110 facing the excitation beam 120 and the IR servo beam 130, and a front panel 2111 on the viewer side of the phosphor layer 2110. In this example, IR feedback marks 2120 are formed on the back surface of the back panel to provide the IR feedback light 132 by reflecting or scattering the IR servo beam 130. In other implementations, the IR feedback marks 2120 may be placed at other positions and can be located on either the excitation side or the viewer side of the phosphor layer 2110.

**[00106]** The IR feedback marks 2120 are designed to provide position registration of the servo beam 130 on the screen and can be implemented in various configurations. For example, the IR feedback marks 2120 can be periodic parallel stripes that are parallel to the parallel phosphor stripes in the phosphor layer 2110. An IR feedback mark 2120 can be placed at any position relative to a stripe divider or a phosphor stripe in the phosphor layer 2110 along the horizontal direction, including a position horizontally displaced from a stripe divider or the center of a phosphor stripe. The width of each of the IR feedback marks 2120 can be equal to the width of the beam spot of the IR servo beam 130 on the screen 101 when the detection for the IR servo feedback light 132 is based on a peak detector. IR feedback marks 2120 with a width wider than the width of the beam spot of the IR servo beam 130 on the screen 101 can be used if the detection for the IR servo feedback light 132 is based on the position of each IR feedback mark 2120 with respect to a position reference such as the SOL mark. The width of the IR feedback marks 2120 may be less than the width of each phosphor stripe, e.g., one half of the width of a phosphor stripe. The spacing between two adjacent IR feedback marks 2120 can be greater than the spacing between two adjacent phosphor stripes. For example, the IR mark spacing can be 25 mm and the phosphor stripe spacing can be 1.5 mm.

**[00107]** The IR feedback marks 2120 can be made to be optically different from the areas surrounding and between the IR feedback marks 2120 to allow for optical detection of the IR

feedback marks 2120 to register the positions of the IR feedback marks 2120 on the screen while maintaining the substantially the same optical transmission for the excitation beam 120 as the areas surrounding and between the IR feedback marks 2120. Therefore, the presence of the IR feedback marks 2120 does not optically interfere with the optical transmission of the excitation beam 120 by optically imprinting the shapes of the marks 2120 on the excitation beam 120 that reaches the phosphor layer of the screen 101. In this regard, the IR feedback marks 2120 can be implemented in various configurations. For example, each IR feedback mark 2120 can be made to have a smooth surface facing the excitation side and optically specularly reflective to light and the areas surrounding and between the IR feedback marks 2120 are configured to exhibit optically diffused reflection which spreads in different directions. The specularly reflective IR feedback marks 2120 and the diffusively reflective areas surrounding and between the marks 2120 have the same optical transmission characteristics. Different from the above design of having specularly reflective marks 2120 in a diffusive background, the IR feedback marks 2120 can also be made diffusively reflective to light and the areas surrounding and between the marks 2120 are made specularly reflective. As another example, the IR feedback marks 2120 can have a transmissivity or reflectivity at the wavelength of the excitation beam 120 that is significantly different from the wavelength of the servo beam and servo wavelengths. For example, the IR feedback marks 2120 can be configured to be optically transparent to light of the excitation beam 120 and optically reflective to light of the servo beam 130 so that the the IR feedback marks 2120 are optically "invisible" to the excitation beam 120 and reflect the servo beam 130 to produce the IR servo feedback light 132.

**[00108]** FIGS. 22 and 23 show examples of screen layout configurations with vertical reference marks 1910 for measuring the vertical positions of the IR servo beam 130. In FIG. 22, the vertical reference marks 1910 are located on the edge of the screen, preferable outside the main display area of the screen. In FIG. 23, the vertical reference marks 1910 are placed at the edges and in the middle of the screen and may be made to have the same optical transmission characteristics for light of the excitation beam 120.

**[00109]** FIG. 24 shows a specific example of a screen design with specularly reflective IR feedback marks and optically diffusive areas surrounding and between the IR feedback marks. In this example, an IR feedback mark is formed by a film stripe that has a smooth surface to produce a specular reflection 2430 of the incident IR servo light 130. The screen area between two IR feedback marks is formed by a film layer with a roughened surface that diffuses light in reflecting the incident IR servo light 130 to produce the diffused reflection

2440 that spreads in different directions forming a diffused reflection cone. The two regions 2410 and 2420 have approximately the same optical transmission for light of the excitation beam 120.

[00110] The above screen design for IR servo feedback can use the different optical behaviors of the specular reflection and the diffusive reflection of the IR servo beam 130 from the screen in the optical far field from the screen to facilitate the servo detection as shown in the example in FIG. 25.

[00111] FIG. 25 shows an exemplary scanning beam display system 2500 that provides an IR servo feedback based on the screen design in FIG. 24. The laser module 110 projects and scans both the IR servo beam 130 and the excitation beam 120 onto the screen 101 with IR feedback marks. The laser module 110 has a symmetric optic axis 2501 around which the beam scanning is performed. The screen 101 has a construction as shown in FIG. 21 or 22 based on the design in FIG. 24. An optical telecentric lens 2510 such as a Fresnel lens layer is provided in to couple the incident scanning beams 120 and 130 from the laser module 110 onto the screen 101 in a substantially normal incidence to the screen 101. The telecentric lens 2510 is configured to have its symmetric optic axis 2502 to be parallel to the optic axis 2501 of the laser module 110 with an offset 2503. As illustrated, the Fresnel lens 2510 is placed in front of the back surface of the screen 101 with an air gap 2520.

[00112] The IR servo detection is provided by using an IR servo detector 2530 located along an optical path of the returned specular reflection 2430 of the incident IR servo light 130 from the IR feedback marks on the screen 101. The location of the IR servo detector 2530 is determined by the offset 2503 for receiving the returned specular reflection 2430 of the incident IR servo light 130 from each IR feedback mark on the screen 101. Returned IR light in a direction different from the specular reflection direction at each IR feedback mark is directed by the Fresnel lens 2510 to miss the IR servo detector 2530 when the deviation from the specular reflection exceeds a range beyond the aperture of the IR servo detector 2530. Under this design, only a very small fraction of the returned IR servo light in the diffused reflection 2440 from an area between IR feedback marks is received by the IR servo detector 2530 and the majority of the returned IR servo light in the diffused reflection 2440 is not collected by the IR servo detector 2530. In contrast, the light in the returned specular reflection 2430 of the incident IR servo light 130 from each IR feedback mark on the screen 101 is substantially collected by the IR servo detector 2530. Based on this difference, the detector signals from the IR servo detector 2530 can be used to determine a hit by the scanning IR servo beam 130 on an IR feedback mark.

[00113] The light of the excitation beam 120 can also be reflected back by the specular and diffusive regions on the screen 101. Hence, the specularly reflected light at the excitation wavelength is directed back to the same location at the IR servo detector 2530. A wavelength selective optical beam splitter can be used to split the collected light at the servo wavelength and the collected light at the excitation wavelength into two separate signals for separate optical detectors, the IR servo detector 2530 to receive the IR servo light and another servo detector to receive the feedback light at the excitation wavelength.

[00114] The scanning IR servo beam 130 can be a CW beam. As such, each hit at an IR feedback mark on the screen produces an optical pulse at the IR servo detector 2530. In each horizontal scan, the IR servo detector 2530 detects a sequence of optical pulses that correspond to the different IR feedback marks on the screen, respectively. The detector output of the IR servo detector 2530 is similar to the detector outputs shown in FIGS. 13-17 obtained by using phosphor strip dividers as IR feedback marks except that the pulse separation in the detector output of the IR servo detector 2530 in time is greater and corresponds to the IR feedback mark spacing. Similarly, SOL or EOL signals can be used to determine the horizontal location of the scanning IR servo beam 130 and vertical reference marks can be used to determine the vertical position of the scanning IR servo beam 130.

[00115] In the system examples in FIGS. 1, 6 and 7, the excitation servo feedback light 122 can be used in combination with the servo feedback based on invisible servo beam 130. In such systems with combination servo controls, the positioning measurements from both the IR servo light feedback and the excitation light servo feedback can be used to calibrate with respect to each other. For example, such a display system can be operated to perform a calibration using the excitation beam 120 and the IR servo beam 130 to scan through the entire screen 101 to measure the position maps of the screen 101 and to use the position map obtained from the excitation beam 120 to calibrate the position map obtained from the IR servo beam 130. Based on this calibration, during the normal operation of the system, the feedback from the IR servo beam 130 can be used, without the feedback based on the excitation light servo feedback, to monitor the screen 101 and to control the timing of pulses in the beam 120 in each horizontal scan.

[00116] In some implementations, the screen 101 can be designed to utilize as much the excitation light for producing the visible light by reducing any optical loss of the excitation light from the excitation beam 120. For example, the screen can be designed to eliminate any optical reflection back to the laser module 110 by using, e.g., an optical layer on the excitation side of the phosphor layer to transmit light of the excitation beam into the

phosphor layer and recycle any excitation light from the phosphor layer back into the phosphor layer. Under such a design, it can be difficult to use light from the excitation beam 120 to produce the servo beam 122. The following sections describe system designs that use visible light emitted by the phosphor layer in the screen 101 to produce a visible servo beam and to provide a second feedback mechanism in addition to the invisible IR servo feedback.

5 [00117] FIG. 26 shows an example of a scanning beam display system 2600 that provides the servo feedback based on the IR servo beam 130 and a second servo feedback based on detection of emitted visible light from the phosphor layer in the screen. In this system, an off-screen optical servo sensing unit 2610 is used to detect the red, green and blue light  
10 emitted from the screen 101. The servo sensing unit 2610 can be located at a location where the emitted visible light from the screen 101 can be detected, e.g., at the viewer side of the screen 101 or at the excitation side of the screen 101 as shown, and the location of the servo sensing unit 2610 can be selected based on the screen design and the system layout. Three optical detectors PD1, PD2 and PD3 are provided in the sensing unit 2610 to detect the red,  
15 green and blue fluorescent light, respectively. Each optical detector is designed to receive light from a part of or the entire screen 101. A bandpass optical filter can be placed in front of each optical detector to select a designated color while rejecting light of other colors. This sensing unit 2610 generates a servo feedback signal 2612 to the laser module 110 for controlling the system operation.

20 [00118] One way to correct the horizontal misalignment in the display systems in FIG. 26 is to program the display processor in the laser module 110 to control the timing of the optical pulses based on the position error detected in the feedback signal 2612. For example, the laser module 110 can delay the modulated image signal carried by the modulated laser beam 120 by one sub color pixel time slot if the green detector has an output and red and blue  
25 detectors have no output or by two sub color pixel time slots if the blue detector has an output and red and green detectors have no output. This correction of a spatial alignment error by a time delay may be achieved digitally within the display processor. No physical adjustment in the optical scanning and imaging units in the laser module 110 is needed. Alternatively, you mean the controller unit in the laser module 110 may be adjusted to physically shift the  
30 position of the excitation beam 120 on the screen 101 so that the laser position on the screen 101 is adjusted horizontally to the left or right by one sub pixel in response to the error detected by the servo sensing unit 2610. The optical alignment by physically adjusting the scanning laser beam 120 and the electronic or digital alignment by controlling the timing of optical pulses can be combined to control the proper horizontal alignment.

[00119] A test pattern can be used to check the horizontal alignment in the display system 2600 in FIG. 26. For example, a frame of one of the red, green and blue colors may be used as a test pattern to test the alignment. FIG. 27A shows a test pattern for the color pixel embedded with the detectors in the servo sensing unit 2610 and the corresponding outputs of the three detectors PD1, PD2 and PD3 when the horizontal alignment is proper without an error. FIGS. 27B, 27C and 27D show three different responses generated by the three detectors PD1, PD2 and PD3 when there is a misalignment in the horizontal direction. The detector responses are fed to the laser module 110 and are used to either use the time-delay technique or the adjustment of the beam imaging optics to correct the horizontal misalignment.

[00120] Hence, the servo feedback control based on sensing the screen-emitted visible light in FIG. 26 is operated in during a designated calibration operation of the system 2600 when the system 2600 is not displaying images for the viewer. This type of feedback control is "static" because the system is operated out of its normal display mode and is operated with test patterns for measuring the alignment conditions of the screen 101. For example, such a static servo feedback algorithm can be performed once at the power-on of the display system or at the factory initial map generation before the system begins the normal display of the images on the screen 101 and the display system can be controlled to perform the initial clock calibration to align the laser pulses to the sub-pixel center positions. Different from the static servo control, a dynamic servo control can also be implemented during the normal display operation mode of the system. For example, the dynamic servo feedback algorithm is performed continuously during the normal operation of the display system. This dynamic servo feedback keeps the pulses timed to the subpixel center position against variations in temperature, screen motion, screen warping, system aging and other factors that can change the alignment between the laser and the screen. The dynamic servo control is performed when the video data is displayed on the screen and is designed in a way that it is not apparent to the viewer. This dynamic control is provided by the invisible servo control in the system 2600 in FIG. 26.

[00121] FIG. 28 illustrates an example of an optical servo design using a visible light servo optical sensor 4501 placed away from a fluorescent screen 101 on the viewer side of the screen 101 in the scanning beam display system 2600. The optical sensor 4501 may be configured and positioned to have a field of view of the entire screen 101. A collection lens may be used between the screen 101 and the sensor 4501 to facilitate collection of the fluorescent light from the screen 101. The optical sensor 4501 can include at least one

optical detector to detect fluorescent light at a selected color, e.g., green from different colors (e.g., red, green and blue) emitted by the screen 101. Depending on the specific techniques used in the servo control, a single detector for a single color may be sufficient for the servo control in some implementations and, in other implementations, two or more optical detectors  
5 for detecting two or more colors of the fluorescent light from the screen 101 may be needed.

Additional detectors may be used to provide detection redundancy for the servo control.

Referring to the reference marks for generating reference signals, detection of such reference signals and control functions based on the reference signals from reference marks, the servo control can be combined with the control functions of the reference marks for the system. In  
10 an example described below, the start of line reference mark outside the screen area having the fluorescent stripes can be used as a timing reference for static servo control of the timing of optical pulses of the scanning beam.

**[00122]** In the example in FIG. 28, the optical sensor 4501 includes three servo optical detectors 4510, 4520 and 4530 (e.g., photodiodes) that detect, respectively, three different  
15 colors emitted by the screen 101. The photodiodes 4510, 4520 and 4530 are arranged in three groupings and each group is filtered by a red filter 4511, a green filter 4521 or a blue filter 4531 so that three photodiodes 4510, 4520 and 4530 receive, respectively, three different colors. Each filter may be implemented in various configurations, such as a film which makes a photodiode sensitive only to one of the red, green and blue colors from the viewing  
20 screen.

**[00123]** The detector circuit for each color group can include a preamplifier (preamp) 4540, a signal integrator (e.g., a charge integrator) 4541, and an A/D converter 4540 to digitize the red, green or blue detector signal for processing in a digital servo circuit 4550 which may be a microcomputer or microprocessor. The red, green and blue light intensities  
25 of the fluorescent light emitted from the screen 101 can be measured and the measured results are sent to the digital servo circuit 4550. The digital servo circuit 4550 can generate and use a reset signal 4552 to reset the integrators 4541 to control the integration operation of the detectors. Using these signals, the digital servo circuit 4550 can determine whether there is an error in the alignment of a scanning laser beam on the screen 101 and, based on the  
30 detected error, determines whether the laser clock is to be advanced or delayed in time in order to center the laser pulses on the subpixels on the screen 101.

**[00124]** The static servo control operations described here are performed when the display system is not in the normal operation for displaying images on the screen. Hence, the regular frame scanning in both directions using the galvo vertical scanner and the polygon

horizontal scanner during the normal operation can be avoided. The vertical scanning by the galvo scanner can be used to direct a scanning laser beam at a desired vertical position and fixed at that position to perform repetitive horizontal scans with different time delays in the laser pulse timing to obtain the desired error signal indicating the laser timing error in the horizontal scan. In addition, a special laser pulse pattern (e.g., FIGS. 27A-D and 29) that does not carry image signals can be used during the static servo operation to generate the error signal.

**[00125]** In the static servo control, the laser pulse pattern for a laser can be chosen to generate a signal that is proportional to the position error of the laser pulses on the screen 101. In one implementation where multiple lasers are used, each laser is pulsed one at a time across the screen 101 and the remaining lasers are turned off. This mode of operation allows the timing for each laser to be measured and corrected independently during a static servo control process.

**[00126]** FIGS. 29 and 30 illustrate one example technique for generating the error signal for implementing the static servo control. FIG. 29 shows an example of a test optical pulse pattern modulated onto a scanning laser beam that has a periodic pulse pattern of laser pulses. The pulse width in time of this test pulse pattern corresponds to a spatial width on the screen that is greater than the width ( $d$ ) of the border between two adjacent subpixels and less than twice of the width ( $D$ ) of a subpixel (one fluorescent stripe). For example, the pulse width in time of this pulse pattern corresponds to a spatial width equal to the width ( $D$ ) of a subpixel. The repetition time of the pulse pattern corresponds to a spatial separation of two adjacent laser pulses on the screen that is equal to the width ( $3D$ ) of one color pixel (three successive fluorescent stripes).

**[00127]** In operation, the timing of the laser pulse pattern in FIG. 29 is adjusted so that each laser pulse partially overlaps with one subpixel and an adjacent subpixel to excite light of different colors in the two adjacent subpixels. Hence, a laser pulse overlapping with two adjacent subpixels (e.g., a red subpixel and a green subpixel) has a red excitation portion that overlaps with the red subpixel to produce red light and a green excitation portion that overlaps with the adjacent green subpixel to produce green light. The relative power levels of the emitted red light and the emitted green light are used to determine whether the center of the laser pulse is at the center of the border between two adjacent subpixels and the position offset between the center of the laser pulse and the center of the border. Based on the position offset, the servo control adjusts the timing of the laser pulse pattern to reduce the offset and to align the center of the laser pulse at the center of the border. Upon completion

of this alignment, the servo control advances or delays the timing of the laser pulse pattern to shift each laser pulse by one half of the subpixel width to place the center of the laser pulse to the center of either of the two adjacent subpixels. This completes the alignment between a laser and a color pixel. During the above process, the vertical scanner is fixed to direct the laser under alignment to a fixed vertical position and the horizontal polygon scanner scans the laser beam repetitively along the same horizontal line to generate the error signal.

**[00128]** The above process uses the relative power levels of the emitted red light and the emitted green light to determine position offset between the center of the laser pulse and the center of the border between two adjacent subpixels. One way to implement this

technique is to use a differential signal based on the difference in the amounts of light emitted by the two different phosphor materials. A number of factors in the servo detection in FIG.

28 can affect the implementation. For example, different fluorescent materials for emitting different colors may have different emission efficiencies at a given excitation wavelength so that, under the same scanning excitation beam, two adjacent subpixels can emit light in two

different colors (e.g., green and red) with different power levels. As another example, the color filters 4511, 4521 and 4531 for transmitting red, green and blue colors may have different transmission values. As yet another example, the optical detectors 4510, 4520, and 4530 may have different detector efficiencies at the three different colors and thus for the same amount of light entered into the detectors at different colors, the detector outputs may

be different. Now consider the condition where the center of a laser pulse is aligned to the center of the border between two adjacent subpixels and thus the laser pulse is equally split between the two adjacent subpixels. Due to the above and other factors, the servo optical detectors corresponding to the emission colors of the two adjacent subpixels may produce two detector outputs of two different signal levels when the laser pulse is equally split

between the two adjacent subpixels. Hence, for a given display system, the servo detector signals can be calibrated to account for the above and other factors to accurately represent the position offset of the laser pulse. The calibration can be achieved via the hardware design,

software in the digital signal processing in the servo digital circuit 4550 in FIG. 28, or a combination of both the hardware design and signal processing software. In the following

sections, it is assumed that the proper calibration is implemented so that the calibrated detector outputs from two different servo optical detectors are equal when the laser pulse is equally split between the two adjacent subpixels.

**[00129]** Therefore, under a proper alignment condition, each of the laser pulses has one half of the pulse over a green subpixel, and the remaining one half of the same pulse over an

adjacent red subpixel. This pulse pattern generates equal amounts of red and green light on the servo detectors when the alignment is proper. Therefore, the difference in the detector output voltage between the red detector and the green detector is an error signal that indicates whether the alignment is proper. When the alignment is proper, the differential signal  
5 between the red and green detectors is zero; and, when the alignment is off from the proper alignment, the difference is either a positive value or a negative value indicating the direction of the offset in alignment. This use of a differential signal between two color channels can be used to negate the importance of measuring the absolute amplitude of the light emanated from the viewing screen phosphor. Alternatively, the difference between two different color  
10 channels, the blue and red detectors or the green and blue detectors, may also be used to indicate the alignment error. In some implementations, because the blue light is closest to the incident excitation laser light wavelength, it can be more practical to use the difference between the green and red detectors for the servo control. An optical sensor for detecting light from the reference mark, which is separate from the optical sensor 4501 for detecting  
15 the fluorescent feedback light from the screen in FIG. 28, is used to generate the detection signal and is connected to the digital servo circuit 4550.

**[00130]** In the static servo control, the start of the timing scan can be corrected first using the test pulse pattern in the scanning laser beam. The timing is corrected for the first group of adjacent pixels along the horizontal scan (e.g., 5 pixels), then the next group of  
20 adjacent pixels of the same size, e.g., the next 5 group, then the next 5 group, until the entire scan has been corrected for a given laser. Here, the number of 5 pixels is chosen as an example for illustration. Such grouping can be used to reduce the amount of time needed for the servo control and to increase the signal-to-noise ratio of the error signal when the signals generated from different pixels in one group are integrated. In practice, the number of pixels  
25 for each of the groups can be selected based on specific requirements of the display system. For example, the severity of the initial timing error may be considered where a small timing error may permit a large number of successive pixels to be in a group for the servo control and a large timing error may require a smaller number of successive pixels to be grouped together for the servo control. In each measurement, the timing error of the scanning beam  
30 can be corrected to one clock cycle of the digital clock of the digital servo circuit 4550. In FIG. 45, digital servo circuit 4550 is a micro-controller which is designed to have timing control for each individual laser and is used to correct the timing of the laser pulse for each pixel.

[00131] Notably, various phosphors can exhibit persistence in fluorescent emission. This property of phosphors can cause the phosphor to produce light after the laser pulse has moved to the next pixel. Referring to FIG. 28, the signal integrator 4541 can be connected at the output of the preamp 4540 for each servo detector to offset this effect of the phosphor.

5 The integrator 4541 can be used to effectively "sum" all the light for a given preamp 4540 over multiple pixels while the reset line for the integrator is low to set the integrator in the integration mode. When the micro-controller initiates an A/D sample, the summed light for a given color is sampled. The reset line 4552 for each integrator 4541 then goes high until the integrator voltage is set back to zero to reset the integrator 4541 and is subsequently released  
10 back to low to restart a new integration period during which the integrator 4541 starts summing the light again.

[00132] FIG. 30 illustrates how the error signal varies as the laser timing is varied from its nominal position directly centered between the red and green subpixels using the laser pulse pattern in FIG. 29. When the error voltage of a differential signal based on the laser  
15 pulse pattern in FIG. 29 is equal to zero as shown in FIG. 30, there are equal amounts of Red and Green light on the red and green servo detectors, and the timing of the laser pulses is directly over the borders between two adjacent sub-pixels. In this manner, the error signal at each sample represents the laser timing error only for the period after the previous reset pulse. Using this scheme, a corrected laser timing map can be generated for each laser on every  
20 horizontal sweep until the entire screen timing is corrected for each laser. The vertical scanner is used to change the vertical position of the horizontal scanning beam from each laser.

[00133] The above technique for generating the static servo error signal uses a border between the two adjacent subpixels as an alignment reference to align the laser pulse in a  
25 laser pulse pattern. Alternatively, the center of each subpixel may be directly used as an alignment reference to center the laser pulses directly over the subpixels without using the borders between two adjacent subpixels. Under this alternative method, the output from a single color servo optical detector is sufficient to generate the error signal for the servo control. An alignment reference mark, such as the start of line (SOL) peripheral alignment  
30 reference mark in FIG. 12 and a separate SOL optical detector that detects the feedback light from the SOL mark, can be used to provide a timing reference and assist the alignment. Referring to FIG. 45, the SOL optical detector is connected to direct its output to the digital servo circuit 4550.

[00134] This alternative static servo technique can be implemented as the follows. A test pulse pattern that has at least one pulse corresponding to one subpixel within a pixel used to modulate the scanning laser beam where the pulse width corresponds to one subpixel width (D) or less. In a horizontal scan, the laser timing is adjusted on the first group of subpixels of the scan after the SOL signal is detected by the SOL optical detector. Based on the timing reference from the SOL signal, the laser timing of the laser pulse pattern is adjusted to maximize the detected optical power of one of the three colors emitted by the fluorescent screen, e.g., the Green light (or Red, or Blue). The adjustment can be achieved by pulsing the laser once per pixel and adjusting the laser timing. When the Green light is maximized on the first 5 pixels, the next five green subpixels are pulsed. The timing is advanced by one clock cycle during one horizontal scan, then delayed by one clock cycle on subsequent laser horizontal scans at the same vertical position on the screen. The timing that produces the maximum Green light is chosen as the correct laser timing. If the output signal from advancing the clock cycle is equal to the output signal from delaying the clock cycle, then the laser timing is proper and is left unchanged. The next 5 pixels are then illuminated with the advanced and delayed laser clock cycles, and the timing that produces the maximum Green light is chosen for this group of 5 pixels. This operation is repeated across the horizontal length of the screen until the end of the screen is reached. This method can also produce a laser clock that is corrected for each laser as the beam from the laser sweeps horizontally across the screen.

[00135] The above static servo control operations are performed when the display system is not in the normal operation and thus a test pulse pattern (e.g., FIG. 29) that does not carry image signals can be used. The dynamic servo correction is performed by using the invisible IR servo feedback during normal operation and viewing of images on the screen.

[00136] On a given horizontal scan, all the lasers can be advanced in phase by one clock cycle of the digital circuit 4550. This operation causes all the laser beams to shift in their positions on the screen by a scanning distance over the one clock cycle and this shift is small when the scanning distance is small (e.g., less than one tenth of the subpixel width). Accordingly, the amplitude of the emitted color light from a subpixel (e.g., the green detector) is slightly changed. On the next frame, all the lasers are delayed in phase by one clock cycle. If the nominal laser pulse position is initially correct, the amplitudes of the delayed and advanced scans of the two different and successive image frames should be equal for any color chosen to be measured and observed. When the amplitudes of the delayed and advanced scans of two different frames are different, there is a laser timing error and a

correction can be applied to the laser timing to reduce the difference in subsequent image frames while the error signal is being monitored and the correction is updated based on the newly generated error signal. The sign of the difference indicates the direction of the offset in the laser timing error so that the servo control can apply the correction to negate the offset.

5 Similar to the second static servo control method described above, the output from a single color servo optical detector is sufficient to generate the error signal for the dynamic servo control.

[00137] FIG. 31 shows a more detailed example of a scanning beam system based on both the dynamic invisible servo feedback and the visible light static servo feedback. An IR servo  
10 detector 620 is provided on the excitation side of the screen 101 to detect the IR servo light 132 reflected from the screen 101 while visible light servo detectors 3110 are placed on the viewer side of the screen 101 to detect screen-emitted visible light 3120 to provide visible light servo detector signals that are fed into the display processor and controller 640. The visible light static servo feedback is used to calibrate the position map of the dynamic IR  
15 servo feedback during a calibration run of the system and the calibrated dynamic IR servo feedback is used during normal operation of the system to correct beam alignment errors.

[00138] While this patent application contains many specifics, these should not be construed as limitations on the scope of an invention or of what may be claimed, but rather as descriptions of features specific to particular embodiments of the invention. Certain features  
20 that are described in this patent application in the context of separate embodiments can also be implemented in combination in a single embodiment. Conversely, various features that are described in the context of a single embodiment can also be implemented in multiple embodiments separately or in any suitable subcombination. Moreover, although features may be described above as acting in certain combinations and even initially claimed as such, one  
25 or more features from a claimed combination can in some cases be excised from the combination, and the claimed combination may be directed to a subcombination or a variation of a subcombination.

[00139] Only a few implementations are disclosed. However, variations and enhancements of the described implementations and other implementations can be made  
30 based on what is described and illustrated in this patent application.

## Claims

What is claimed is:

1. A scanning beam display system, comprising:
  - an excitation light source to produce at least one excitation beam having optical pulses that carry image information;
  - a servo light source to produce at least one servo beam at a servo beam wavelength that is invisible;
  - a beam scanning module to receive the excitation beam and the servo beam and to scan the excitation beam and the servo beam;
  - a light-emitting screen positioned to receive the scanning excitation beam and the servo beam and comprising a light-emitting area which comprises (1) parallel light-emitting stripes which absorb light of the excitation beam to emit visible light to produce images carried by the scanning excitation beam, and (2) stripe dividers parallel to and spatially interleaved with the light-emitting stripes with each stripe divider being located between two adjacent stripes, each stripe divider being optically reflective;
  - an optical servo sensor positioned to receive light of the servo beam scanning on the screen including light reflected by the stripe dividers and to produce a monitor signal indicative of positioning of the servo beam on the screen; and
  - a control unit operable to, in response to the positioning of the servo beam on the screen in the monitor signal, adjust timing of the optical pulses carried by the scanning excitation beam based on a relation between the servo beam and the excitation beam to control the spatial alignment of spatial positions of the optical pulses in the excitation beam on the screen.
2. The system as in claim 1, wherein:
  - the servo beam wavelength is greater than each wavelength in a visible spectral range of the visible light emitted by the light-emitting stripes.
3. The system as in claim 1, wherein:
  - the servo beam and the excitation beam co-propagate along a common optical path from the beam scanning module to the screen.

4. The system as in claim 1, wherein:

the screen comprises a reflective stripe line as a start of line servo reference mark outside the light-emitting area of the screen and parallel to the light-emitting stripes to indicate a reference position of the servo beam and a reference position of the excitation beam during a beginning of a beam scan of the servo beam or the horizontal beam perpendicular to the light-emitting stripes, and

the control unit is operable to, based on received light of the servo beam from the start of line servo reference mark and the stripe dividers, to control the spatial alignment of spatial positions of the optical pulses in the excitation beam on the screen, when the excitation beam scans in the light-emitting area and produces the images.

5. The system as in claim 4, wherein:

the screen comprises a vertical beam position servo reference mark outside the light-emitting area in a beam scanning path perpendicular to the light-emitting stripes, the vertical beam position servo reference mark producing a vertical beam position servo feedback light when illuminated by the scanning beam to indicate information on a vertical beam position in a vertical direction parallel to the light-emitting stripes.

6. The system as in claim 5, wherein:

the a vertical beam position servo reference mark comprises first and second servo marks separated from each other along the beam scanning path.

7. The system as in claim 1, wherein:

the beam scanning module includes two beam scanners to scan the excitation and servo beams along two orthogonal directions and a projection lens downstream from the two beam scanners to project the scanning excitation and servo beams onto the screen.

8. The system as in claim 1, wherein:

the beam scanning module includes two beam scanners to scan the excitation and servo beams along two orthogonal directions and a projection lens located along an optical path between the two beam scanners to project the scanning excitation and servo beams onto the screen.

9. The system as in claim 1, wherein:

the optical servo sensor comprises a first optical photodetector responsive to light of the servo beam to produce a detector signal for received light of the servo beam.

**10.** The system as in claim 1, wherein:

the optical servo sensor comprises a first optical photodetector and a first optical filter to filter light entering into the first photodetector to allow passage of the light of the servo beam into the first optical photodetector while rejecting light of the at least one excitation beam.

**11.** The system as in claim 1, wherein:

the optical servo sensor comprises:

a first optical photodetector and a first optical filter to filter light entering into the first photodetector to allow passage of the light of the servo beam into the first optical photodetector while rejecting light of the at least one excitation beam; and

a second optical photodetector and a second optical filter to filter light entering into the second photodetector to allow passage of the light of the at least one excitation beam into the second optical photodetector while rejecting light of the servo beam.

**12.** The system as in claim 11, wherein:

the screen comprises a reflective stripe line as a start of line servo reference mark outside the light-emitting area of the screen and parallel to the light-emitting stripes to indicate a reference position of the servo beam and a reference position of the excitation beam, and

the control unit is operable to, based on received light of the servo beam and the at least one excitation beam from the start of line servo reference mark from the first and second photodetectors, to determine a relative position between the servo beam and the at least one excitation beam, and to control the spatial alignment of spatial positions of the optical pulses in the excitation beam on the screen.

**13.** The system as in claim 1, wherein:

the screen comprises a filter located on one side of the screen opposite to a side that faces the excitation light source, the filter operable to transmit the visible light and to block light of the servo beam.

**14.** A method for controlling a scanning beam display system, comprising:

- scanning at least one excitation beam modulated with optical pulses on a screen with parallel light-emitting stripes in a beam scanning direction perpendicular to the light-emitting stripes to excite the fluorescent strips to emit visible light which forms images, wherein the screen comprises stripe dividers parallel to and spatially interleaved with the light-emitting stripes with each stripe divider being located between two adjacent stripes and each stripe divider is optically reflective;
- scanning a servo beam, which is invisible, along with the excitation beam on the screen;
- detecting light of the scanning servo beam from the screen including light produced by the stripe dividers to obtain a monitor signal indicative of positioning of the servo beam on the screen; and
- in response to the positioning of the servo beam on the screen, adjusting timing of the optical pulses carried by the scanning excitation beam based on a relation between the servo beam and the excitation beam to control the spatial alignment of spatial positions of the optical pulses in the excitation beam on the screen.

**15.** The method as in claim 14, comprising:

- prior to scanning the at least one excitation beam modulated with optical pulses to display images on the screen, performing a calibration scan to:
  - scanning the least one excitation beam in a continuous wave mode to scan over the entire screen;
  - detecting reflected excitation light from the stripe dividers to measure peak reflected signals corresponding to the stripe dividers;
  - processing the reflected excitation light to extract pixel information of pixels on the screen; and
  - using the extracted pixel information of pixels on the screen to control timing of optical pulses in subsequent scanning of the at least one excitation beam modulated with optical pulses to display images on the screen,
- wherein the positioning of the servo beam on the screen is used to modify timing of the optical pulses set by using the extracted pixel information of pixels on the screen.

**16.** The method as in claim 14, wherein:

the screen comprises a reflective stripe line as a start of line servo reference mark outside an area of the screen having the light-emitting stripes, the reflective stripe line being parallel to the light-emitting stripes to indicate a reference position of the servo beam and a reference position of the excitation beam s, and

the method comprising:

detecting light of the servo beam and the at least one excitation beam from the start of line servo reference mark, to determine a relative position between the servo beam and the at least one excitation beam, and to control the spatial alignment of spatial positions of the optical pulses in the excitation beam on the screen.

**17.** The method as in claim 14, comprising:

using a vertical beam position reference mark on the screen that is located outside an area having the parallel light-emitting stripes to reflect light of the at least one excitation beam;

measuring the reflected light from the beam position reference mark to detect a vertical alignment error of the at least one excitation beam; and

adjusting the at least one excitation beam to reduce the vertical alignment error.

**18.** The method as in claim 14, comprising:

using a vertical beam position reference mark on the screen that is located outside an area having the parallel light-emitting stripes to reflect light of the servo beam;

measuring the reflected light from the beam position reference mark to detect a vertical alignment error of the servo beam; and

adjusting the servo beam to reduce the vertical alignment error.

**19.** A scanning beam display system, comprising:

a light-emitting screen comprising a light-emitting area which comprises (1) parallel light-emitting stripes which absorb excitation light to emit visible light, and (2) optically reflective stripe dividers parallel to and spatially interleaved with the light-emitting stripes with each stripe divider being located between two adjacent stripes;

a plurality of excitation lasers to produce excitation laser beams of the excitation light;

at least one servo light source fixed in position relative to the excitation lasers to produce at least one servo beam at a servo beam wavelength that is invisible;

a beam scanning module to receive the excitation laser beams and the servo beam and to scan the excitation laser beams and the servo beam;

at least one first optical servo sensor positioned to receive light of the servo beam reflected from the screen to produce a first monitor signal indicative of positioning of the servo beam on the screen;

at least one second optical servo sensor positioned to receive light of the excitation laser beams reflected from the screen to produce a second monitor signal indicative of positioning of each excitation laser beam on the screen; and

a control unit operable to, in response to the first and the second monitor signals, adjust timing of the optical pulses carried by each excitation laser beam based on a relation between the servo beam and each excitation laser beam to control the spatial alignment of spatial positions of the optical pulses in the excitation beam on the screen.

**20.** The system as in claim 19, wherein:

the screen comprises a reflective stripe line as a start of line servo reference mark outside the light-emitting area of the screen and parallel to the light-emitting stripes to indicate a reference position of the servo beam and a reference position of each excitation laser beam, and

the control unit is operable to, based on received light of the servo beam and each excitation laser beam from the start of line servo reference mark, to determine a relative position between the servo beam and each excitation laser beam, and to control the spatial alignment of spatial positions of the optical pulses in the excitation beam on the screen.

**21.** A scanning beam display system, comprising:

a light module to direct and scan at least one excitation beam having optical pulses that carry image information and at least one servo beam at a servo beam wavelength different from a wavelength of the excitation beam;

a screen positioned to receive the scanning excitation beam and the servo beam and comprising a light-emitting layer of parallel light-emitting stripes which absorb light of the excitation beam to emit visible light to produce images carried by the scanning excitation beam, the screen configured to reflect light of the servo beam towards the light module to produce servo feedback light; and

an optical servo sensor module positioned to receive the servo feedback light and to produce a servo feedback signal indicative of positioning of the servo beam on the screen,

wherein the light module is responsive to the positioning of the servo beam on the screen in the servo feedback signal to adjust timing of the optical pulses carried by the scanning excitation beam to control the spatial alignment of spatial positions of the optical pulses in the excitation beam on the screen.

**22.** The system as in claim 21, wherein:

the screen comprises servo feedback marks that have facets facing the excitation light source that are specularly reflective to light of the servo beam, and areas outside the servo feedback marks that are diffusively reflective to light of the servo beam;

wherein the system comprises a Fresnel lens located between the screen and the light module to direct the scanning servo beam and excitation beam to be at a substantially normal incidence to the screen, and

wherein the Fresnel lens has an optic axis symmetrically in a center of the Fresnel lens to be parallel to and offset from an optic axis of the light module to direct light of the servo beam that is specularly reflected by a servo feedback mark into the optical servo sensor while light of the servo beam that is diffusely reflected by the screen outside a servo feedback mark is spread by the Fresnel lens over an area greater than the optical servo sensor to direct a fraction of diffusely reflected light of the servo beam into the optical servo sensor.

**23.** The system as in claim 22, wherein:

the servo feedback marks are parallel stripes that are parallel to the parallel light-emitting stripes in the screen and have facets facing the excitation light source that are specularly reflective to light of the servo beam.

**24.** The system as in claim 21, comprising:  
a second optical servo sensor module located relative to the screen to receive a portion of the visible light emitted by the screen to produce a second servo feedback signal, and  
wherein the control unit is operable to calibrate positioning of the servo beam on the screen in the servo feedback signal with respect to positioning information in the second servo feedback signal.

**25.** The system as in claim 24, wherein:  
the second optical servo sensor module include a plurality of optical detectors to respectively detect visible light of different colors emitted by the screen.

**26.** The system as in claim 21, wherein:  
the servo beam is an IR beam.

**27.** A method for controlling a scanning beam display system, comprising:  
scanning one or more excitation beams modulated with optical pulses to carry images on a screen to excite parallel light-emitting strips to emit visible light which forms the images;  
scanning a servo beam at an optical wavelength different from an optical wavelength of the one or more excitation beams, on the screen;  
detecting light of the servo beam from the screen to obtain a servo signal indicative of positioning of the servo beam on the screen; and  
in response to the positioning of the servo beam on the screen, controlling the one or more scanning excitation beams to control the spatial alignment of spatial positions of the optical pulses in each excitation beam on the screen.

**28.** The method as in claim 27, comprising:  
detecting a portion of reflected light of the one or more excitation beams from the screen to provide a second servo signal indicative of positioning of an excitation beam on the screen; and  
using information in the servo signal and the second servo signal to control the spatial alignment of spatial positions of the optical pulses in each excitation beam on the screen.

**29.** The method as in claim 27, comprising:

detecting a portion of visible light of emitted from the screen to provide a second servo signal indicative of positioning of an excitation beam on the screen; and

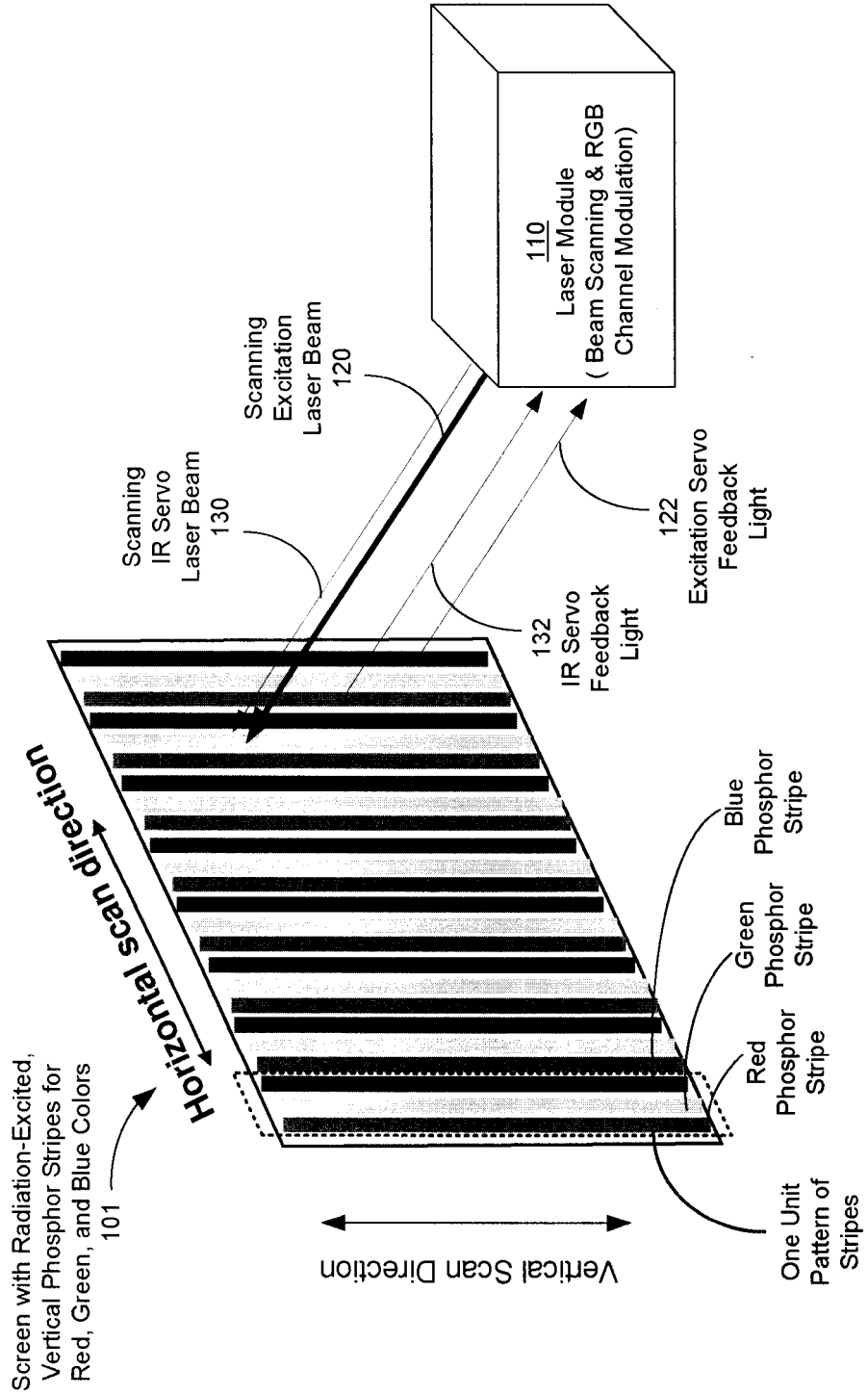
using information in the servo signal and the second servo signal to control the spatial alignment of spatial positions of the optical pulses in each excitation beam on the screen.

**30.** The method as in claim 27, comprising:

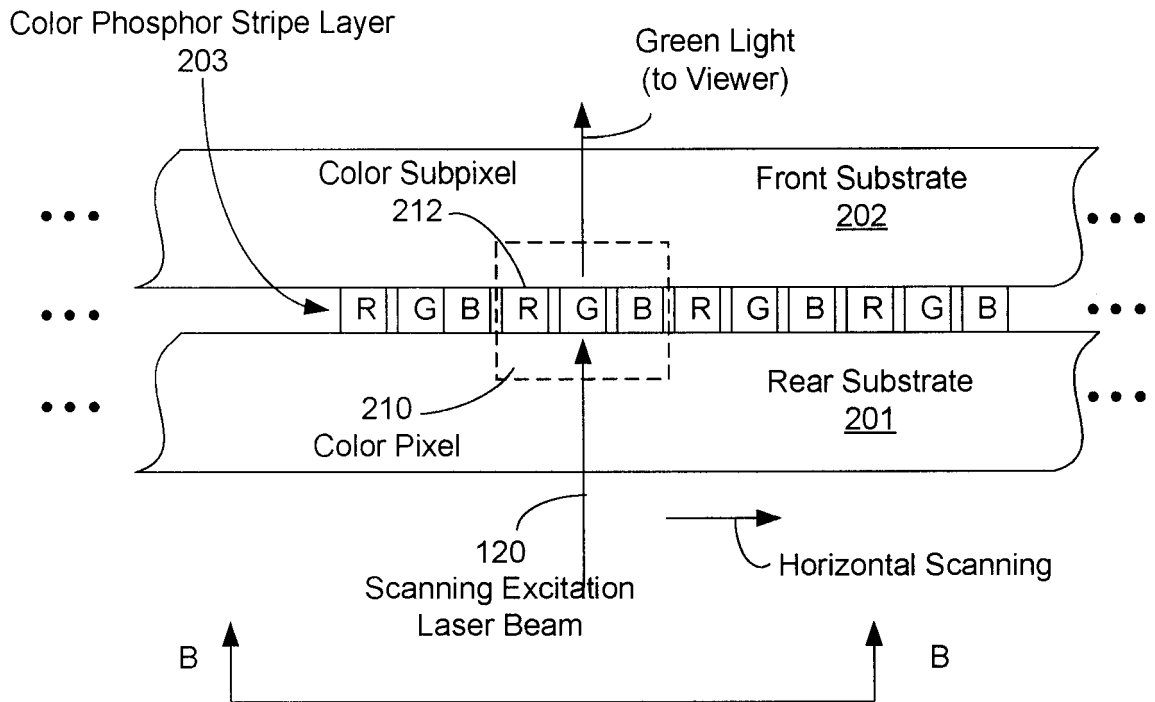
detecting light reflected from a reference line mark on the screen that is spaced away from and is parallel to the parallel light-emitting strips on the screen as a start of line reference to measure a position of a beam relative to an edge of the parallel light-emitting strips; and

using the measured position from the reference line mark to control timing of the optical pulses in each excitation beam in displaying the images on the screen.

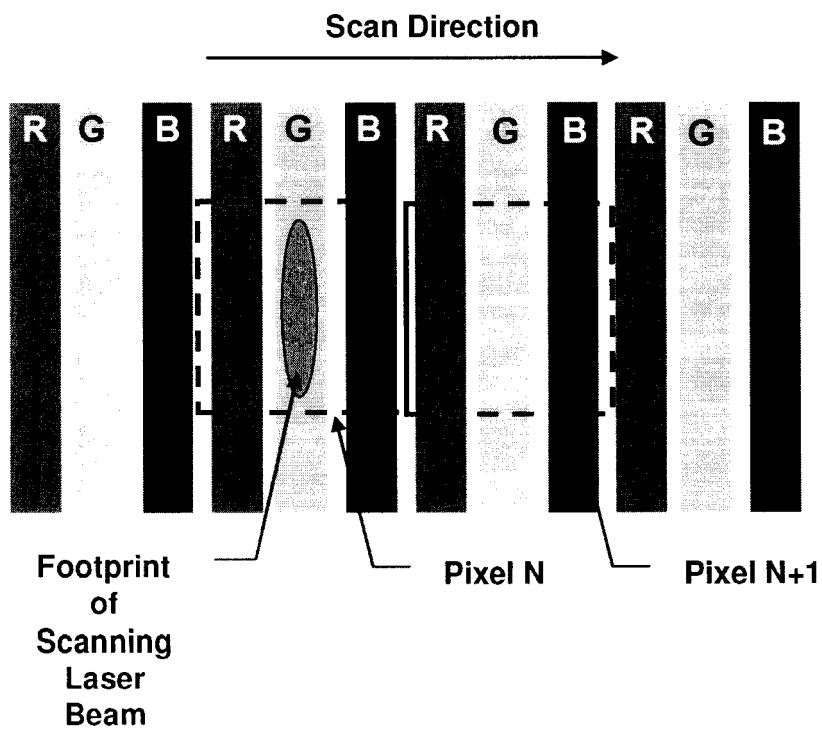
FIG. 1



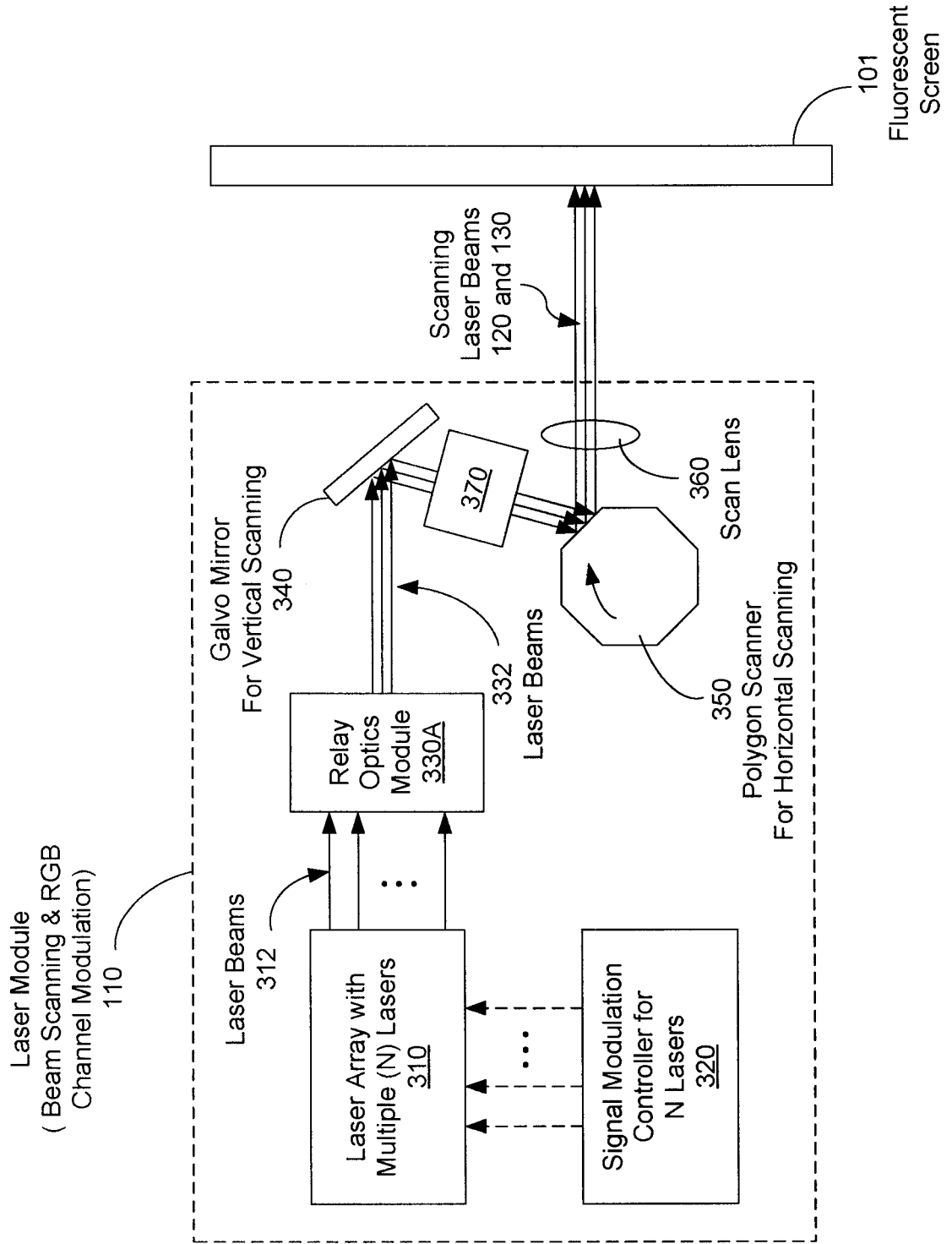
**FIG. 2A**



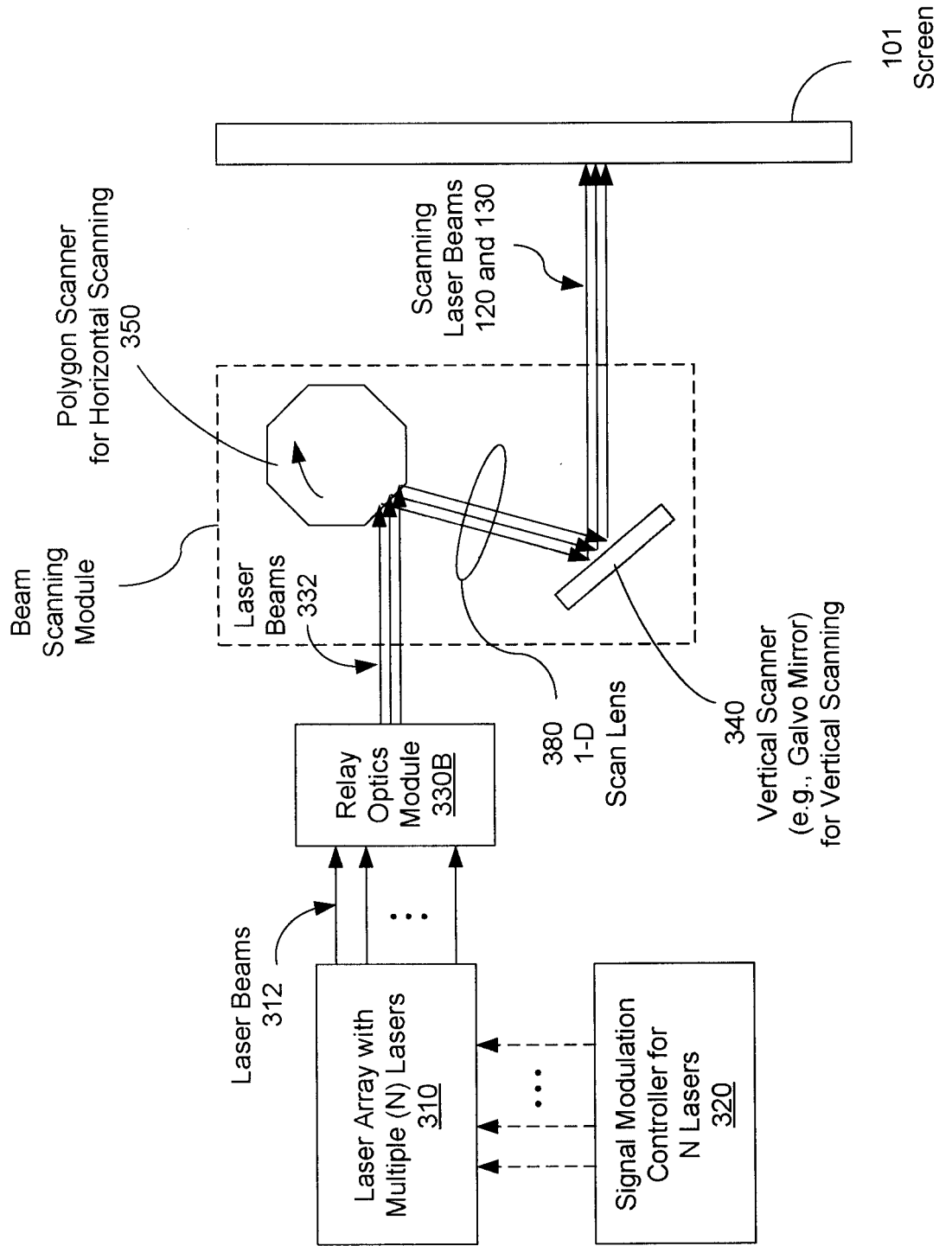
**FIG. 2B**



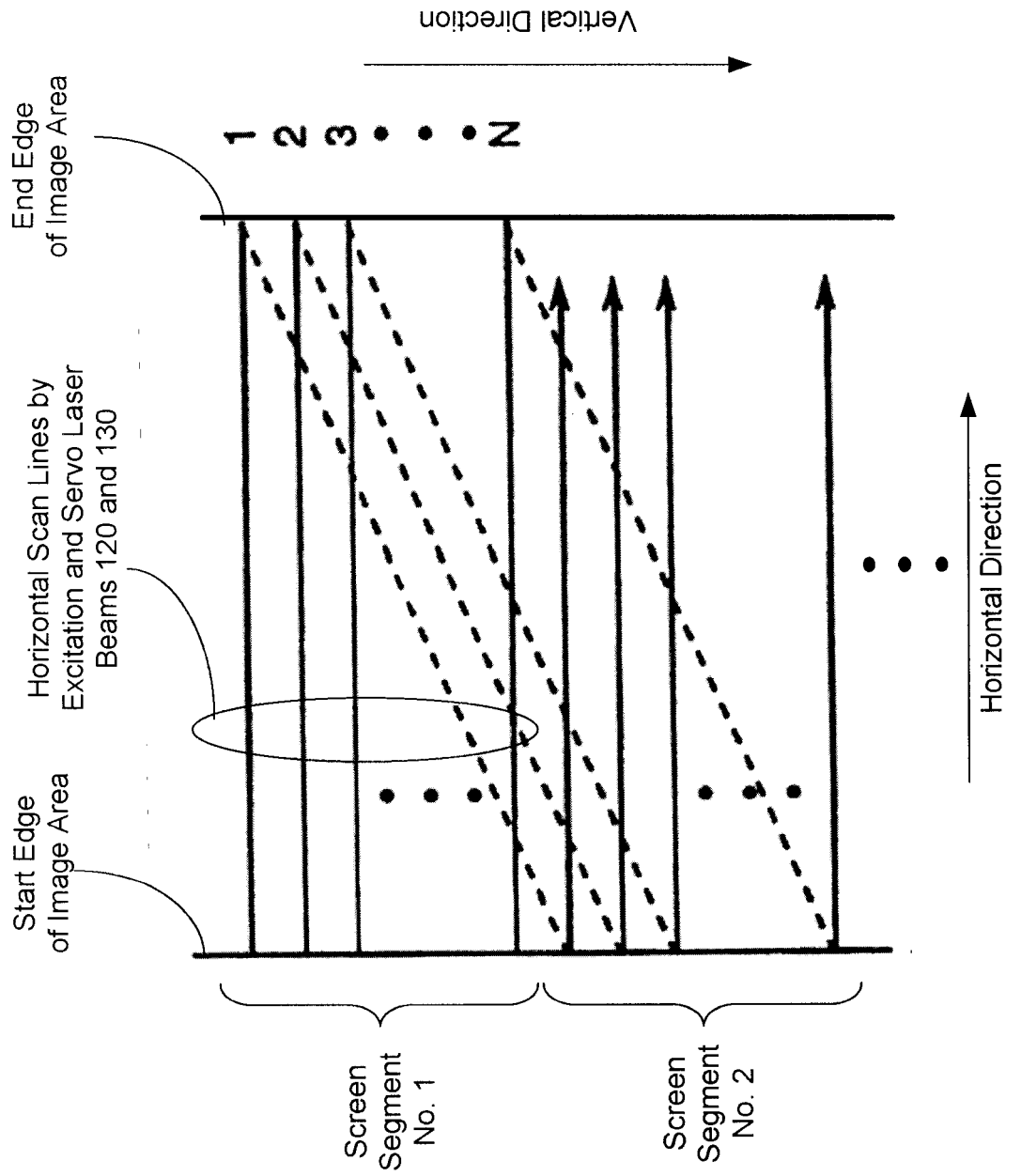
**FIG. 3**



**FIG. 4**



**FIG. 5**



**FIG. 5A**

IR Servo Beam Spot  $\diamond$   
Excitation Laser Beam Spot  $\blacklozenge$

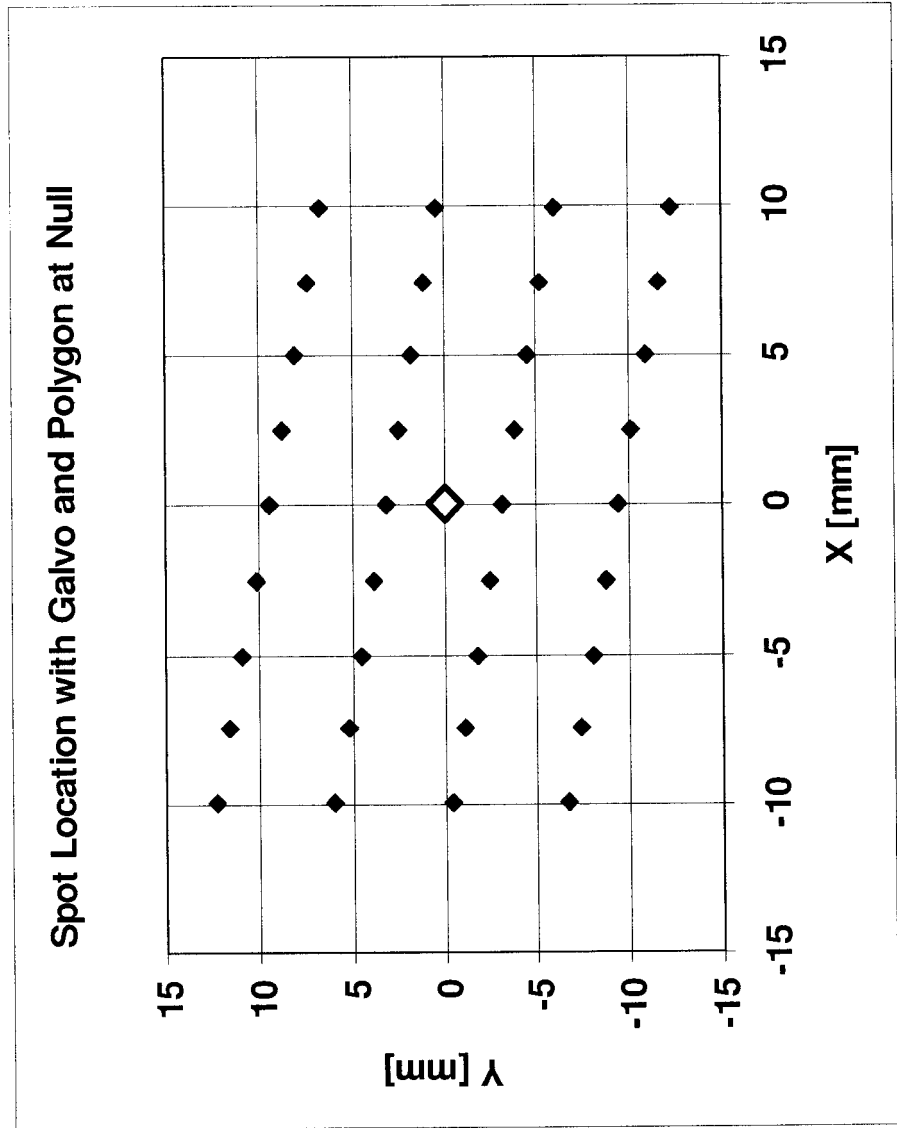
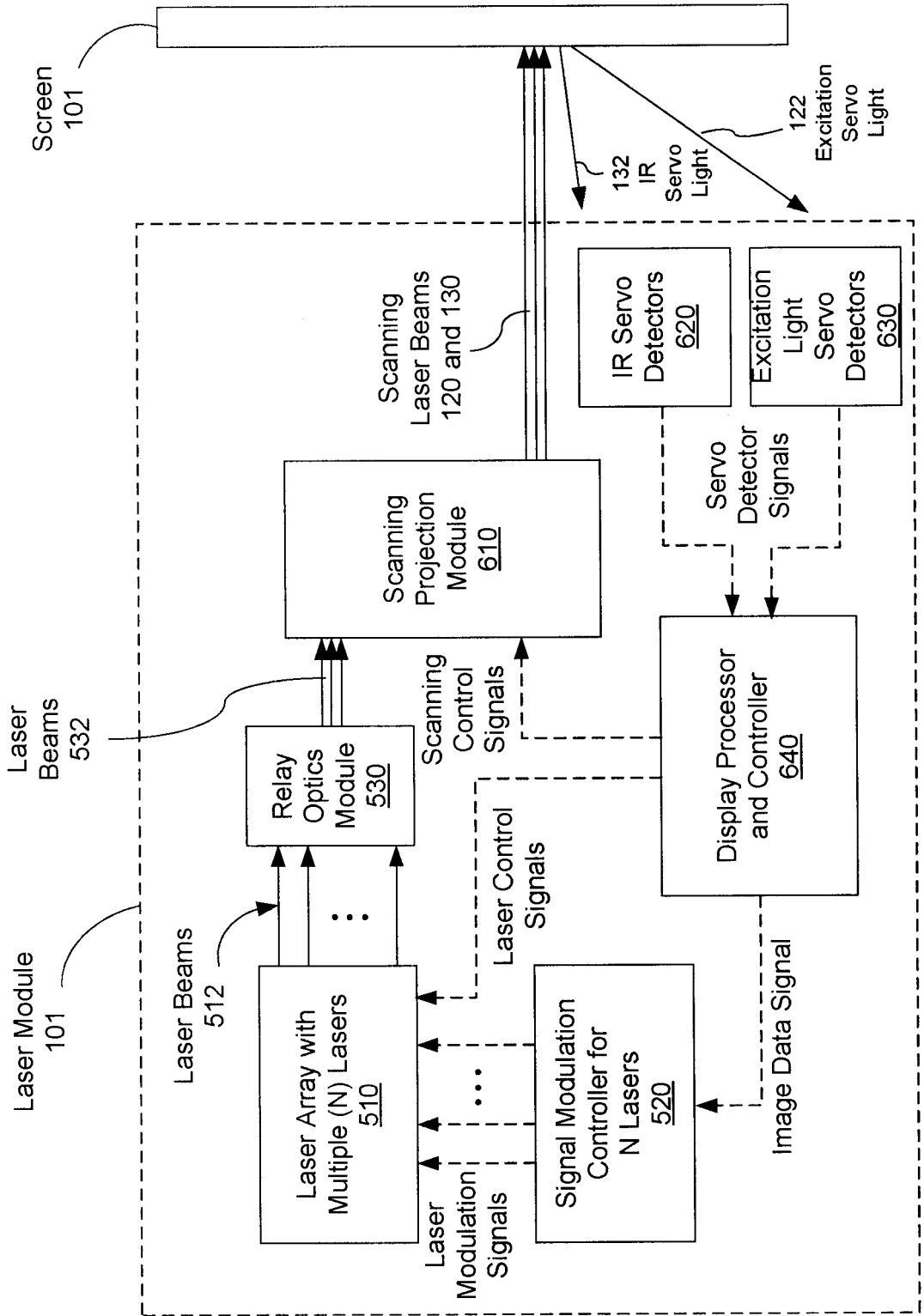


FIG. 6



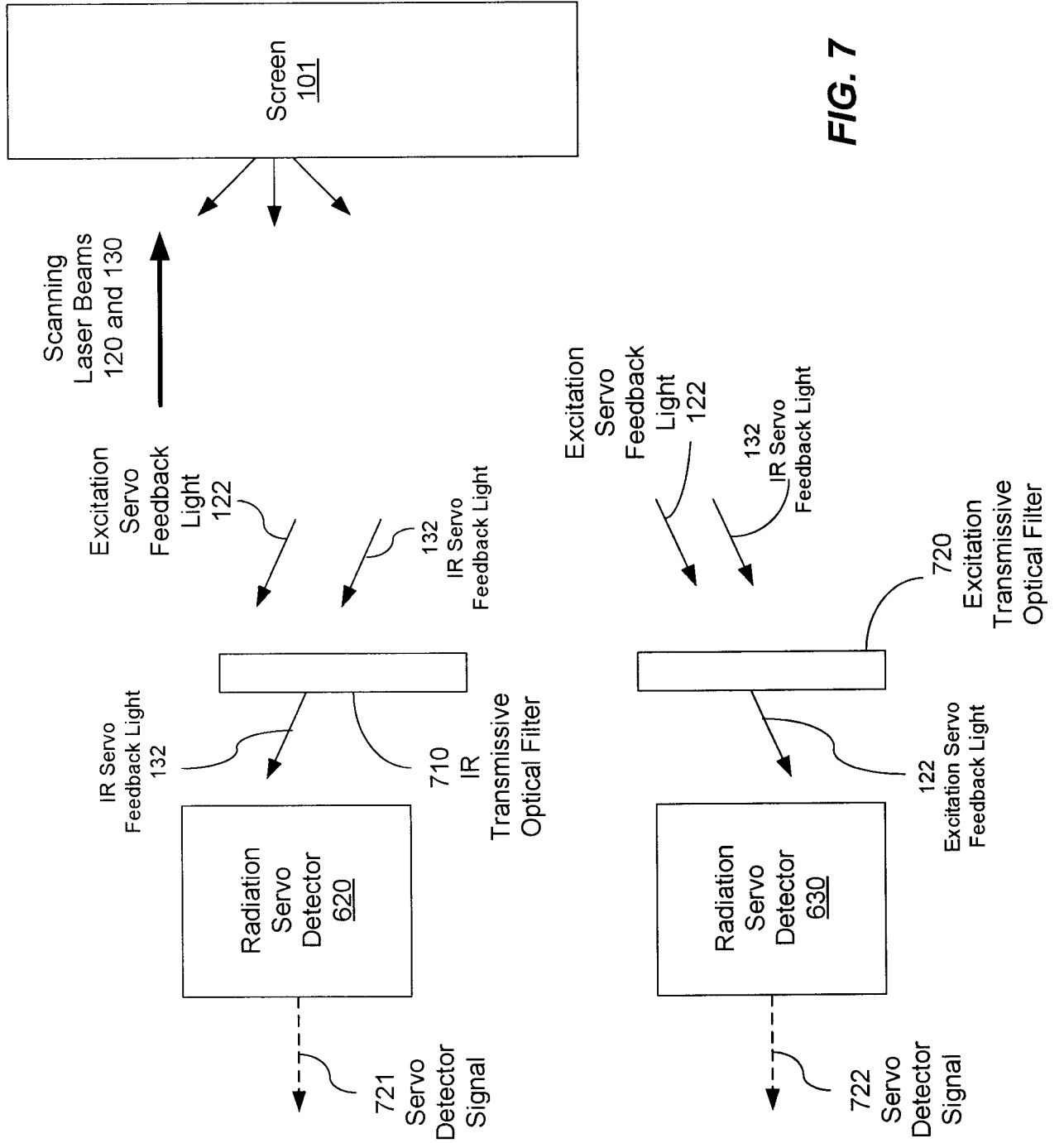
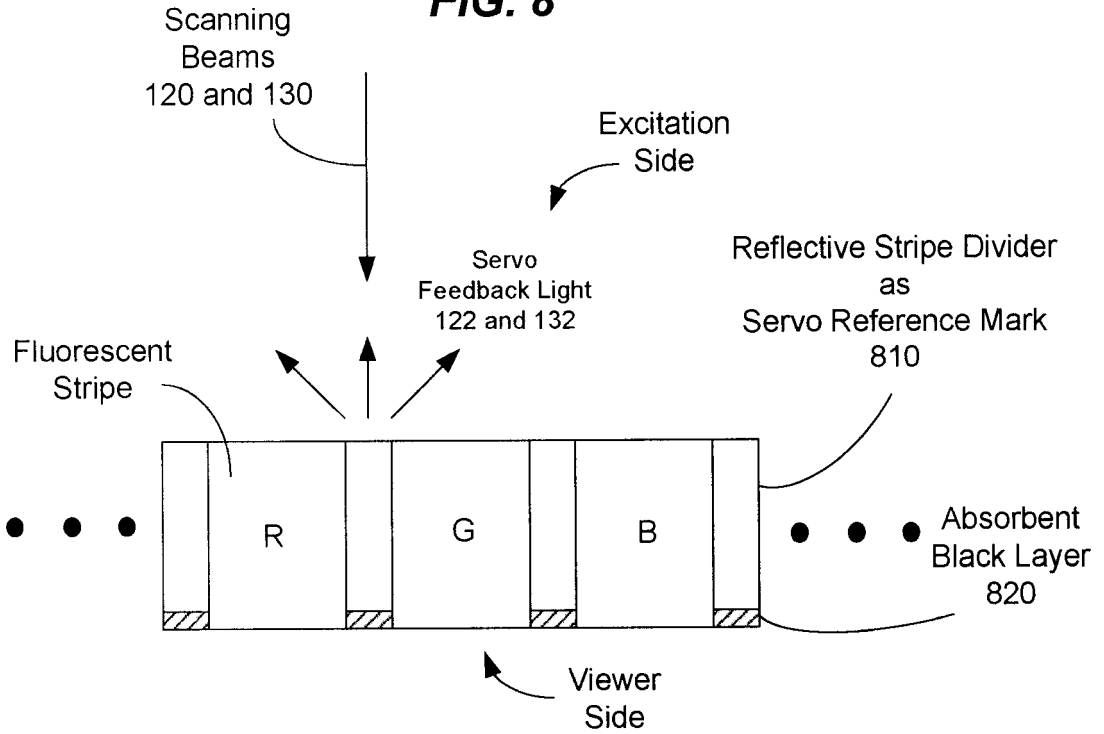
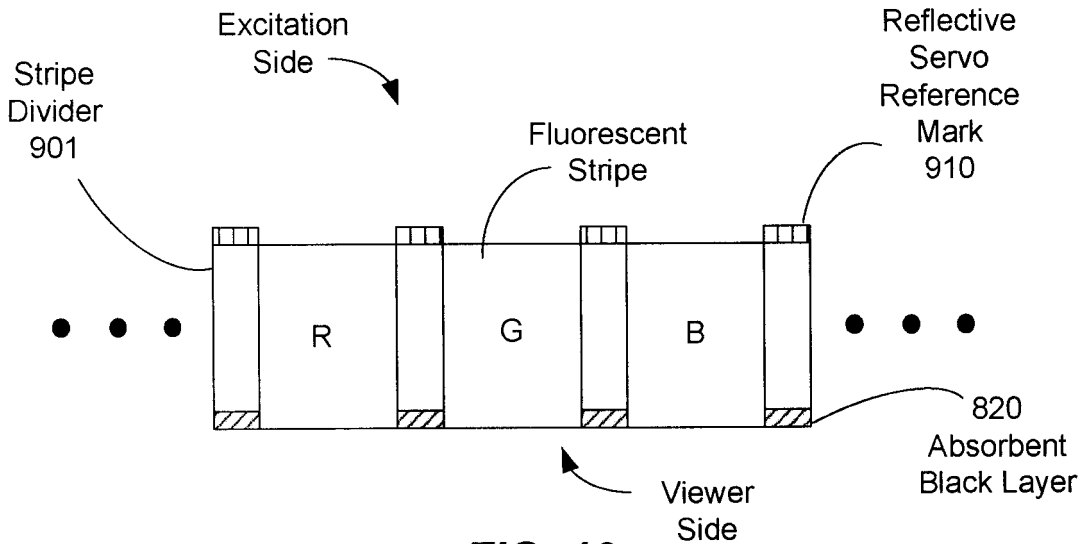


FIG. 7

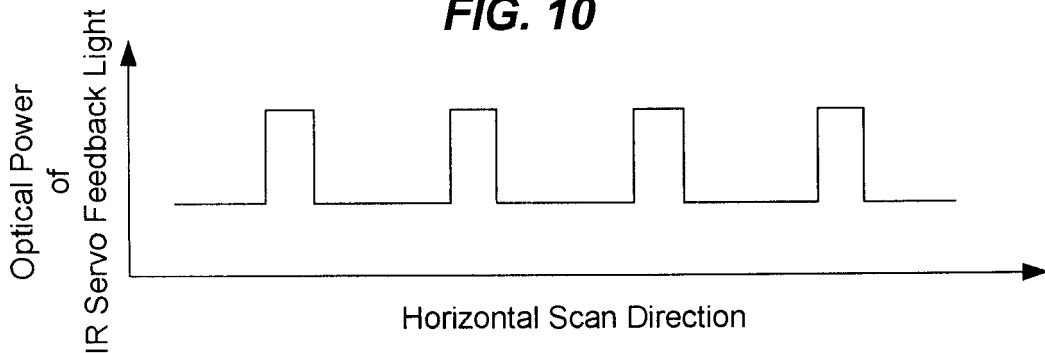
**FIG. 8**



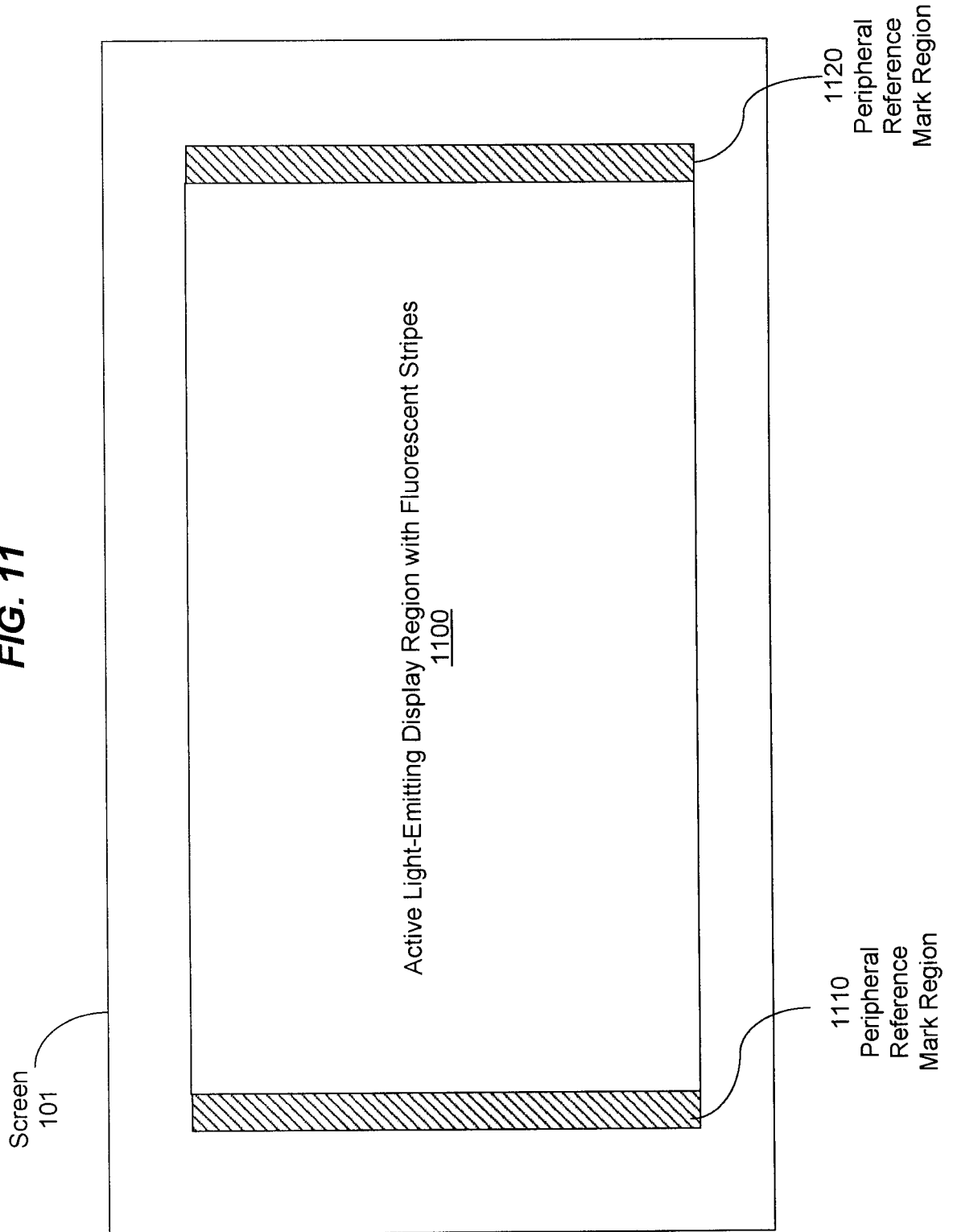
**FIG. 9**



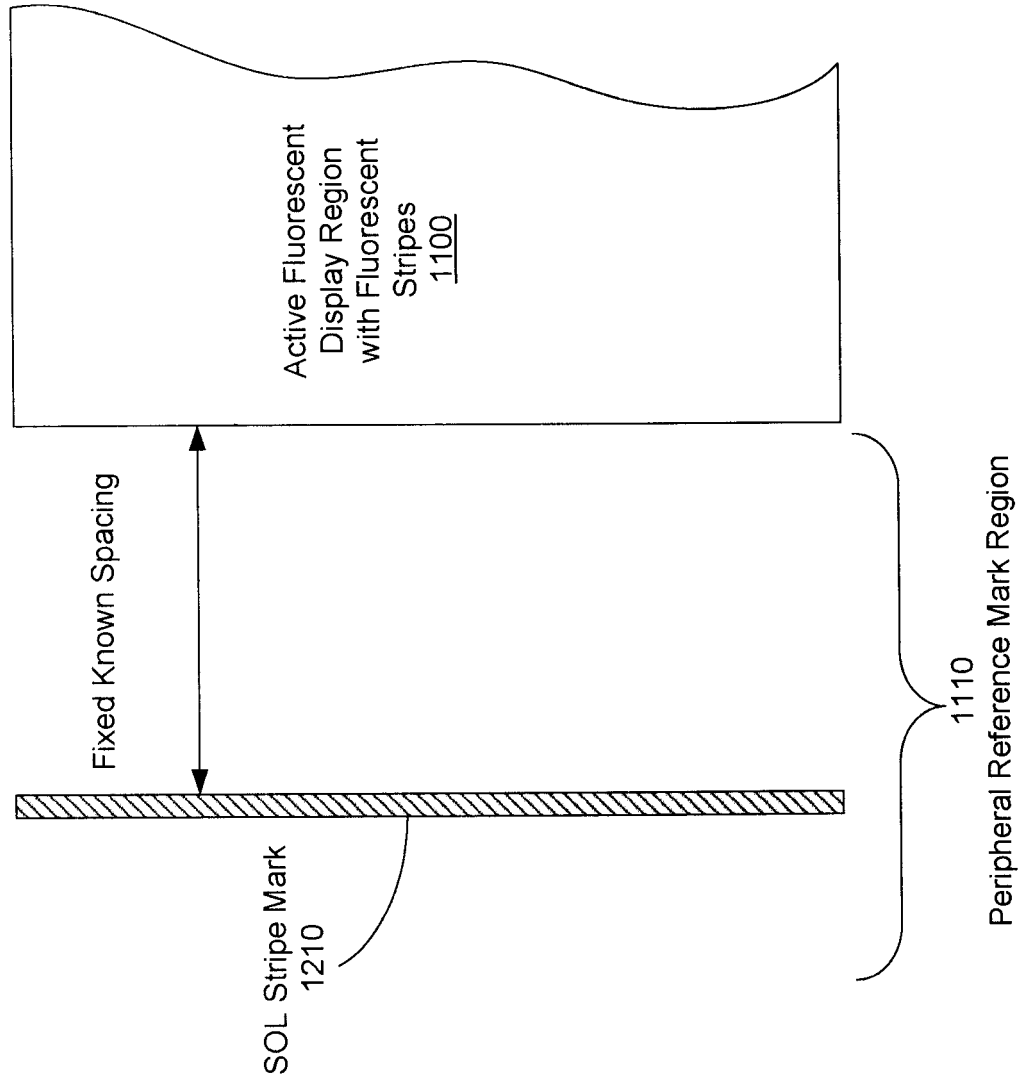
**FIG. 10**



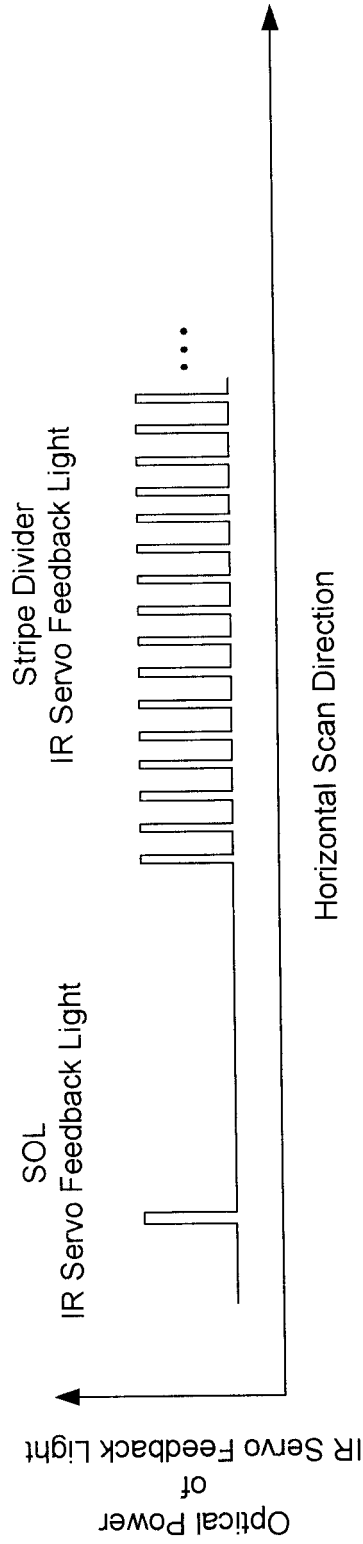
**FIG. 11**



**FIG. 12**



**FIG. 13**



**FIG. 14**

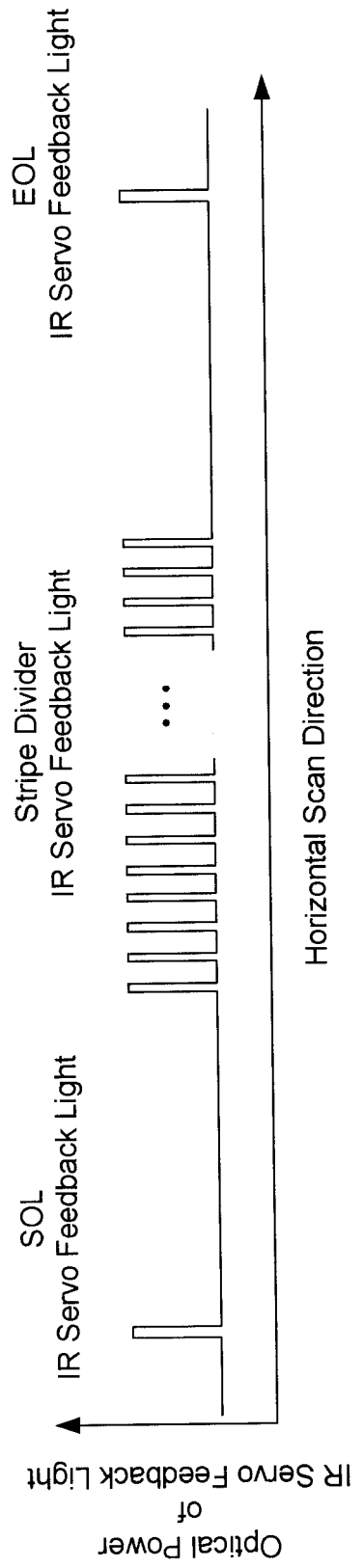
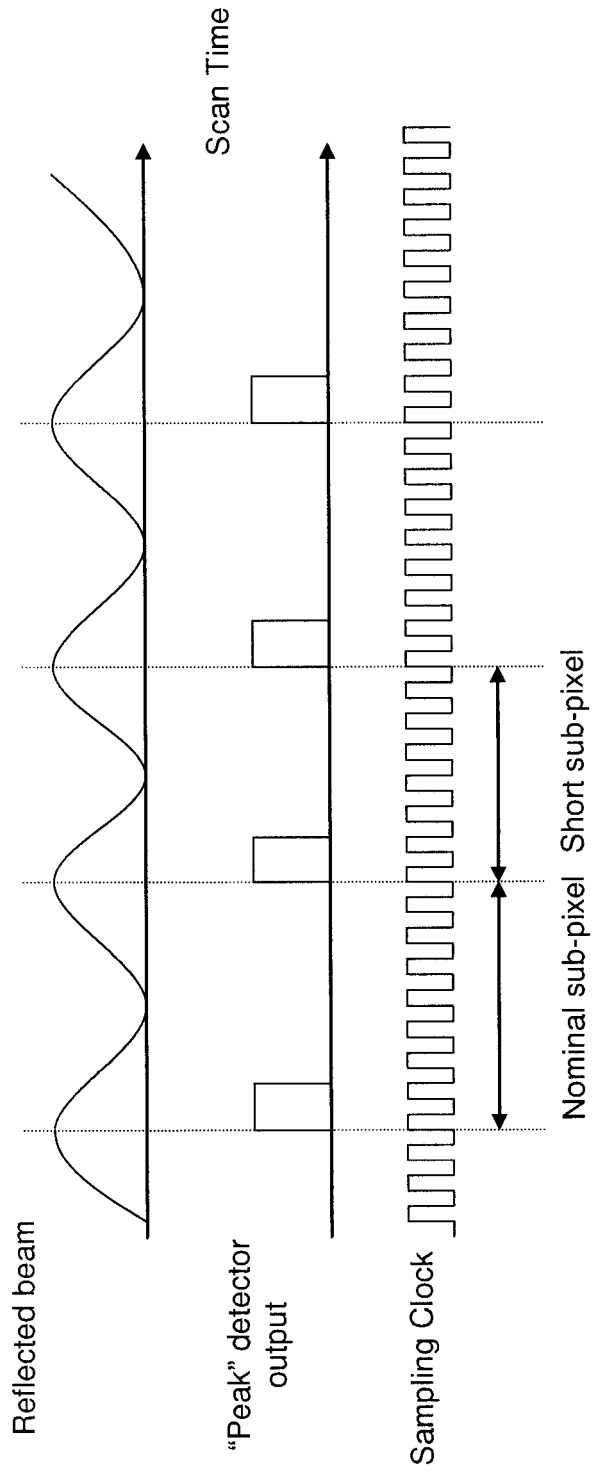
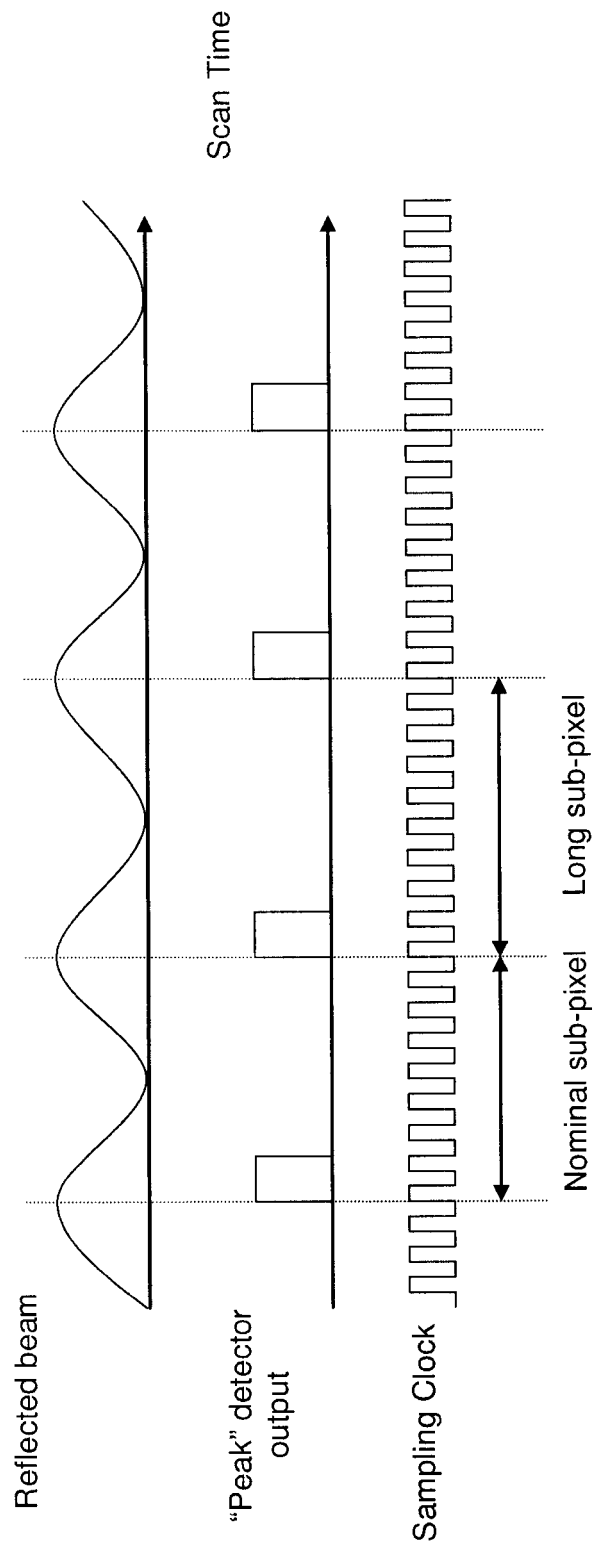


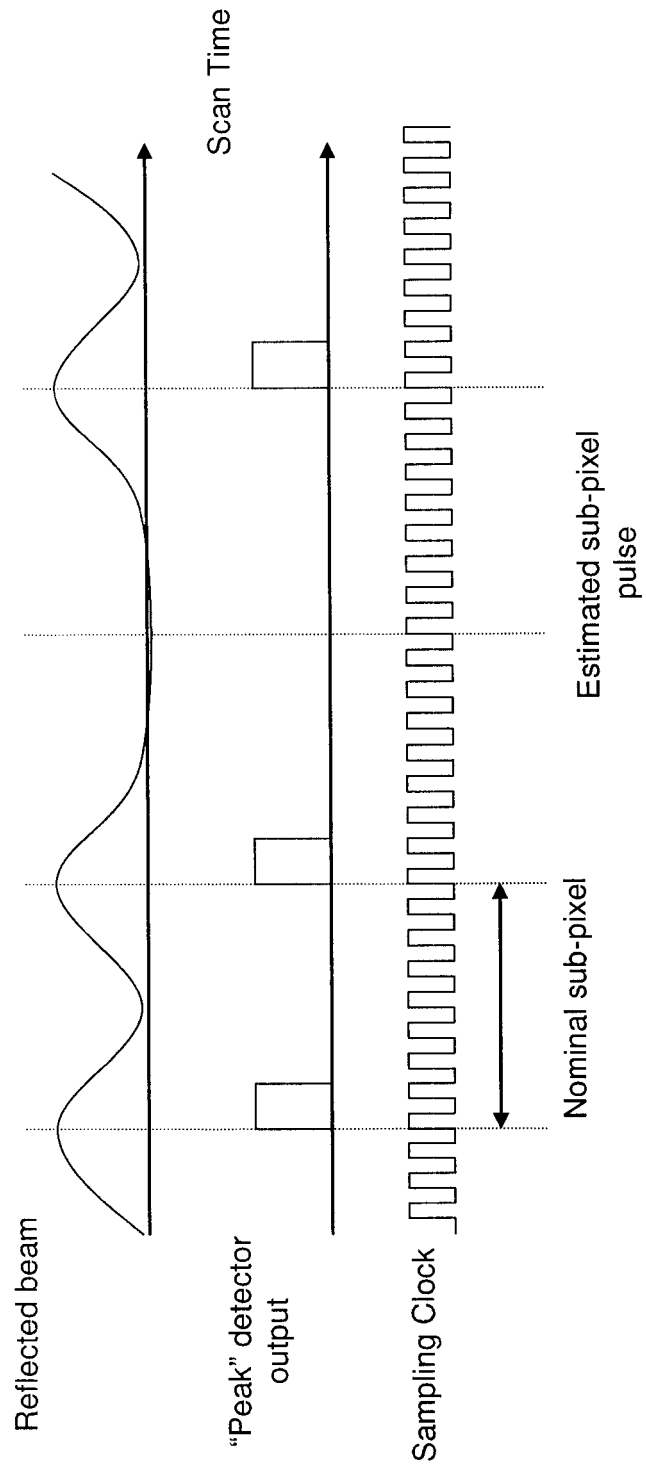
FIG. 15



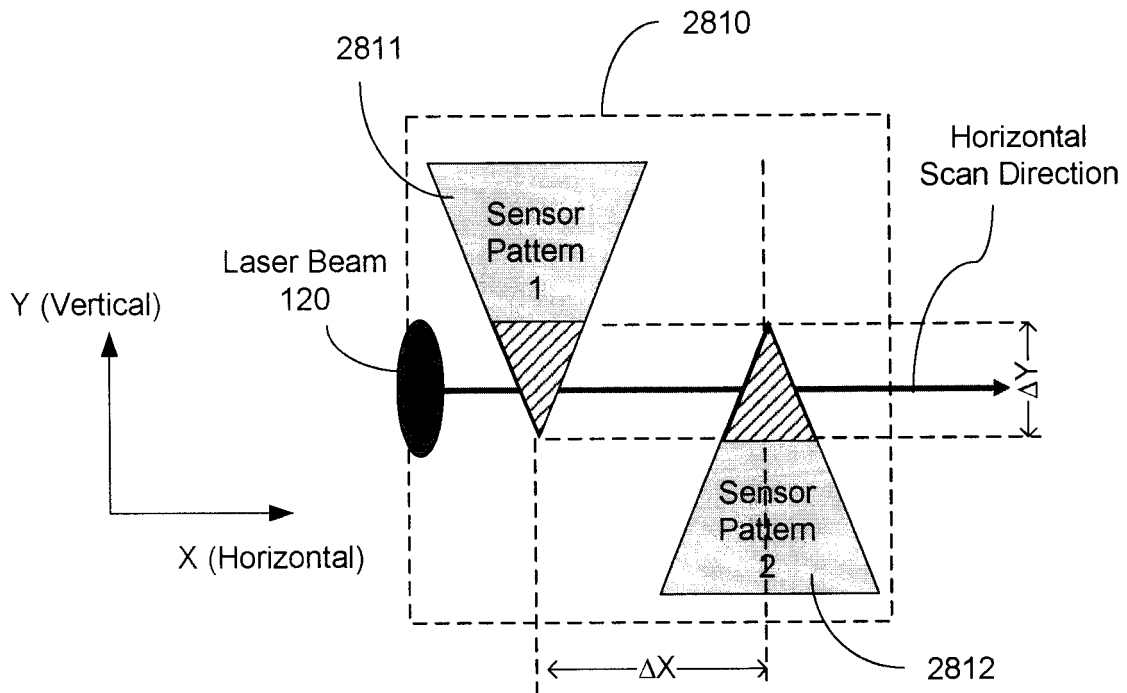
**FIG. 16**



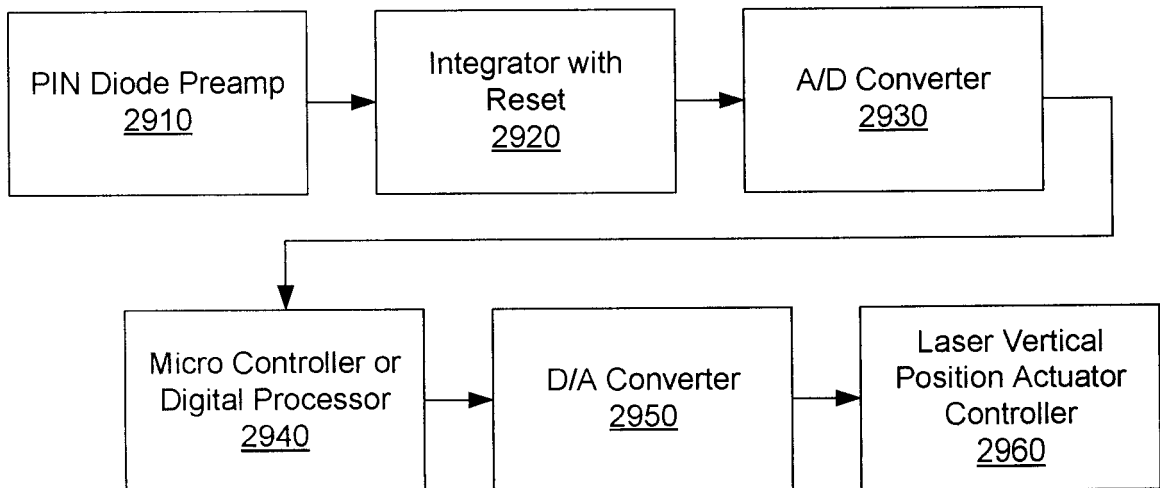
**FIG. 17**



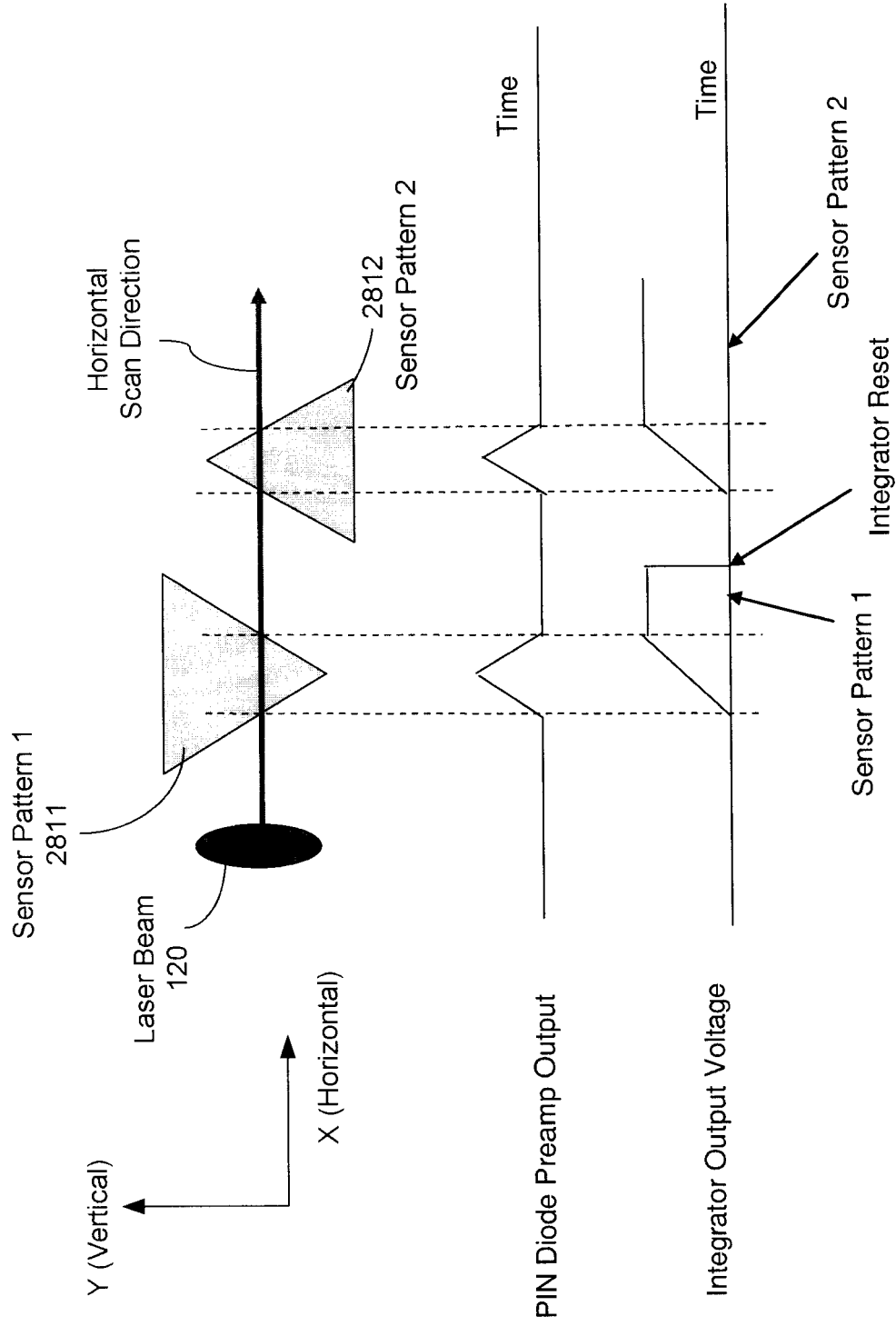
**FIG. 18A**



**FIG. 18B**

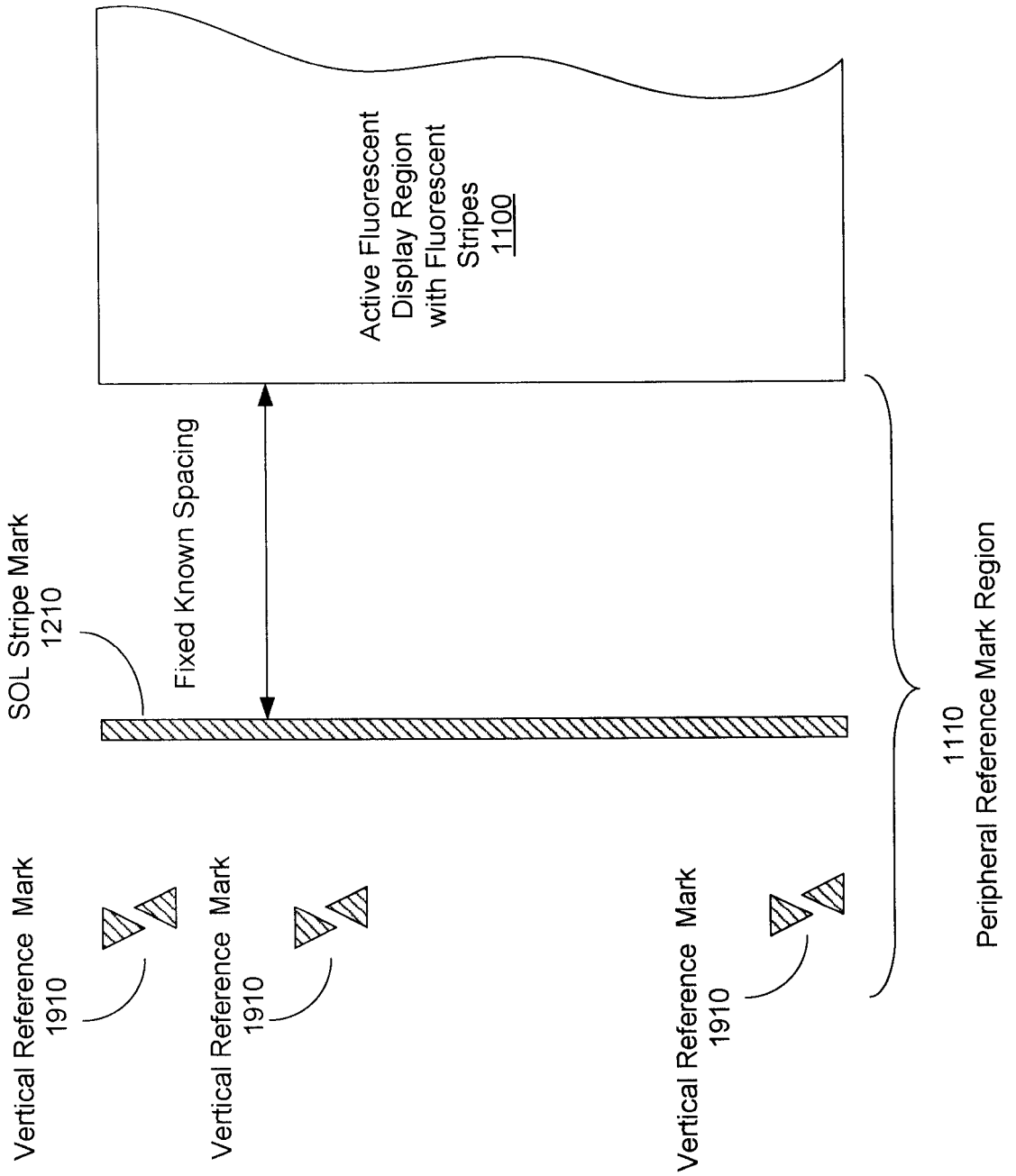


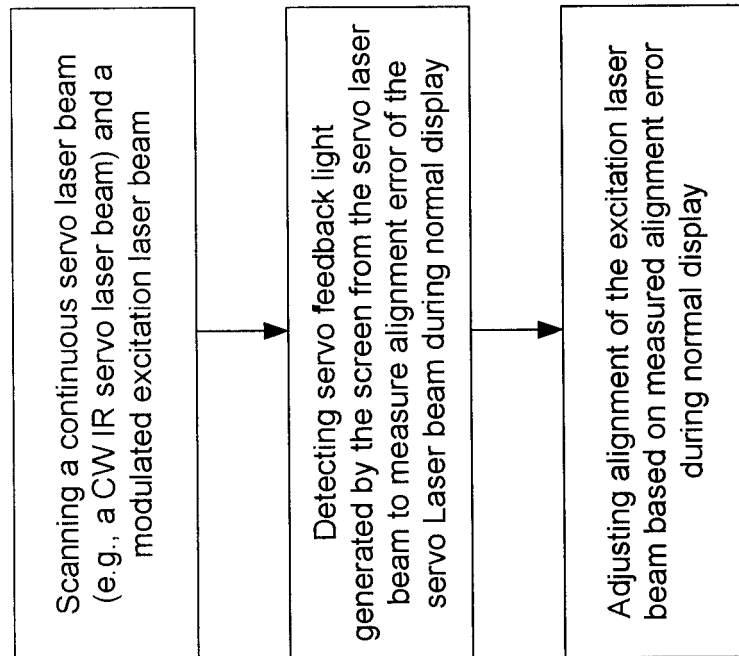
**FIG. 18C**



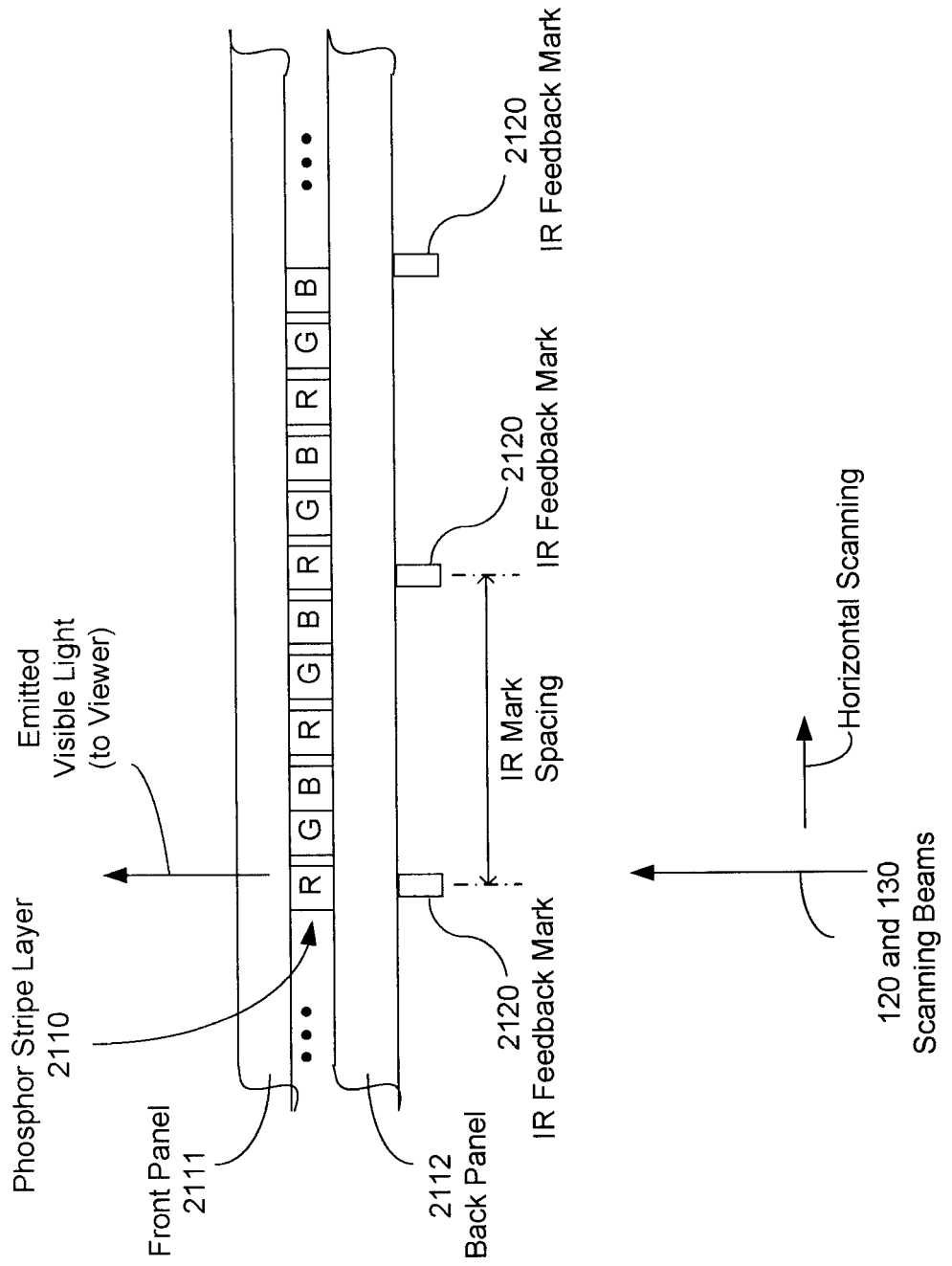
$$\text{Position Error Voltage} = (\text{Sensor Pattern 1} - \text{Sensor Pattern 2}) / (\text{Sensor Pattern 1} + \text{Sensor Pattern 2})$$

**FIG. 19**

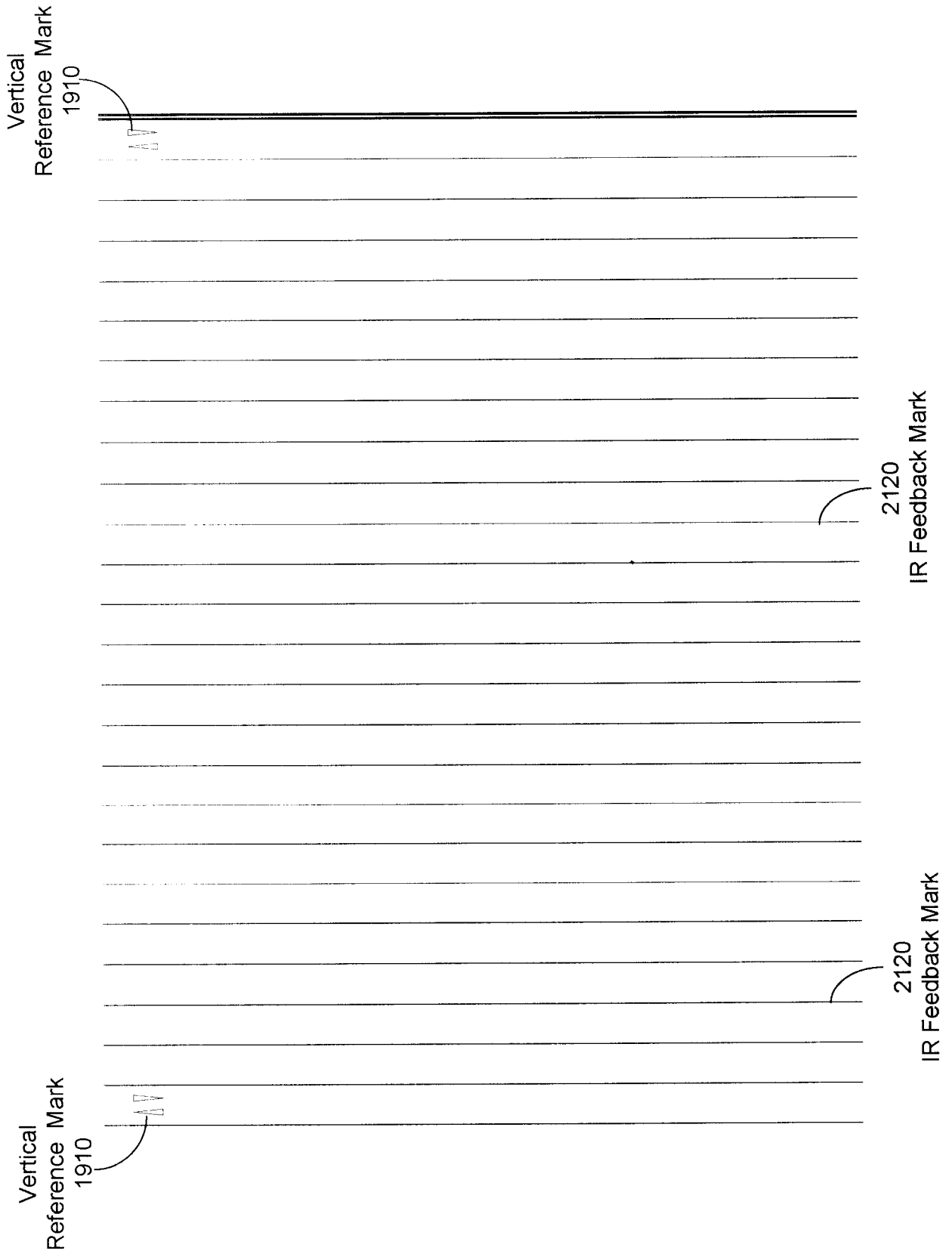


**FIG. 20**

**FIG. 21**



**FIG. 22**



**FIG. 23**

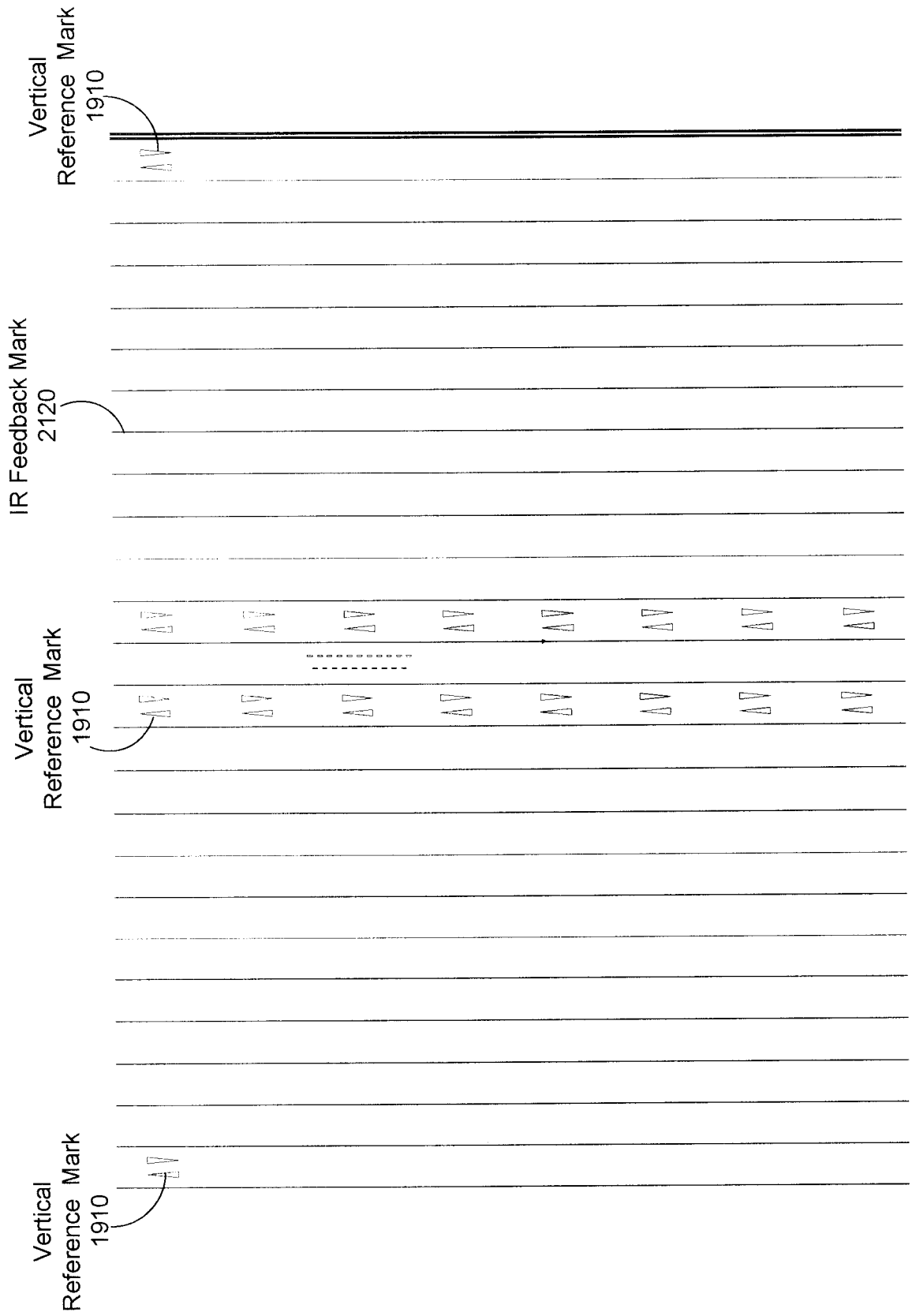
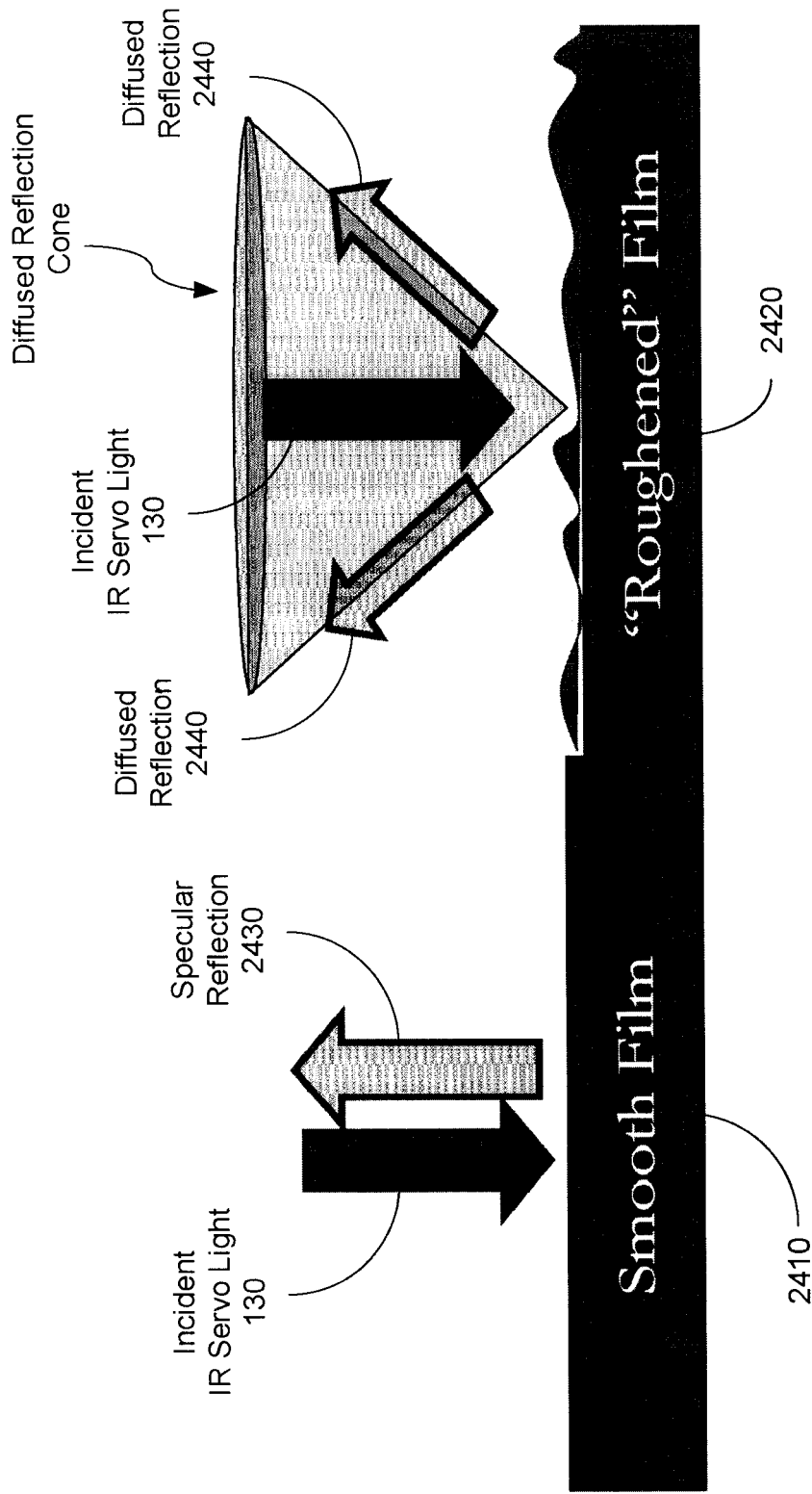


FIG. 24



**FIG. 25**

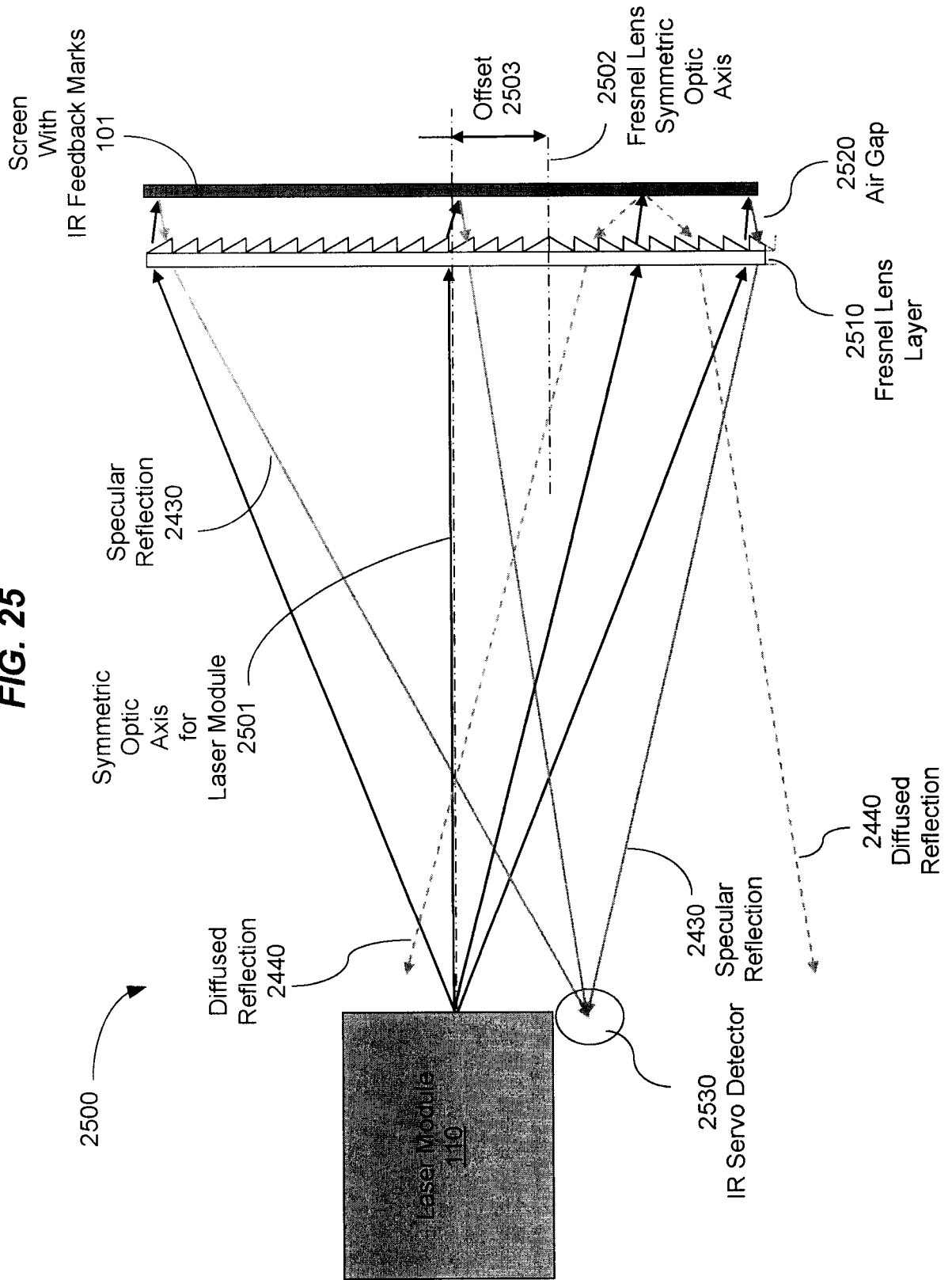
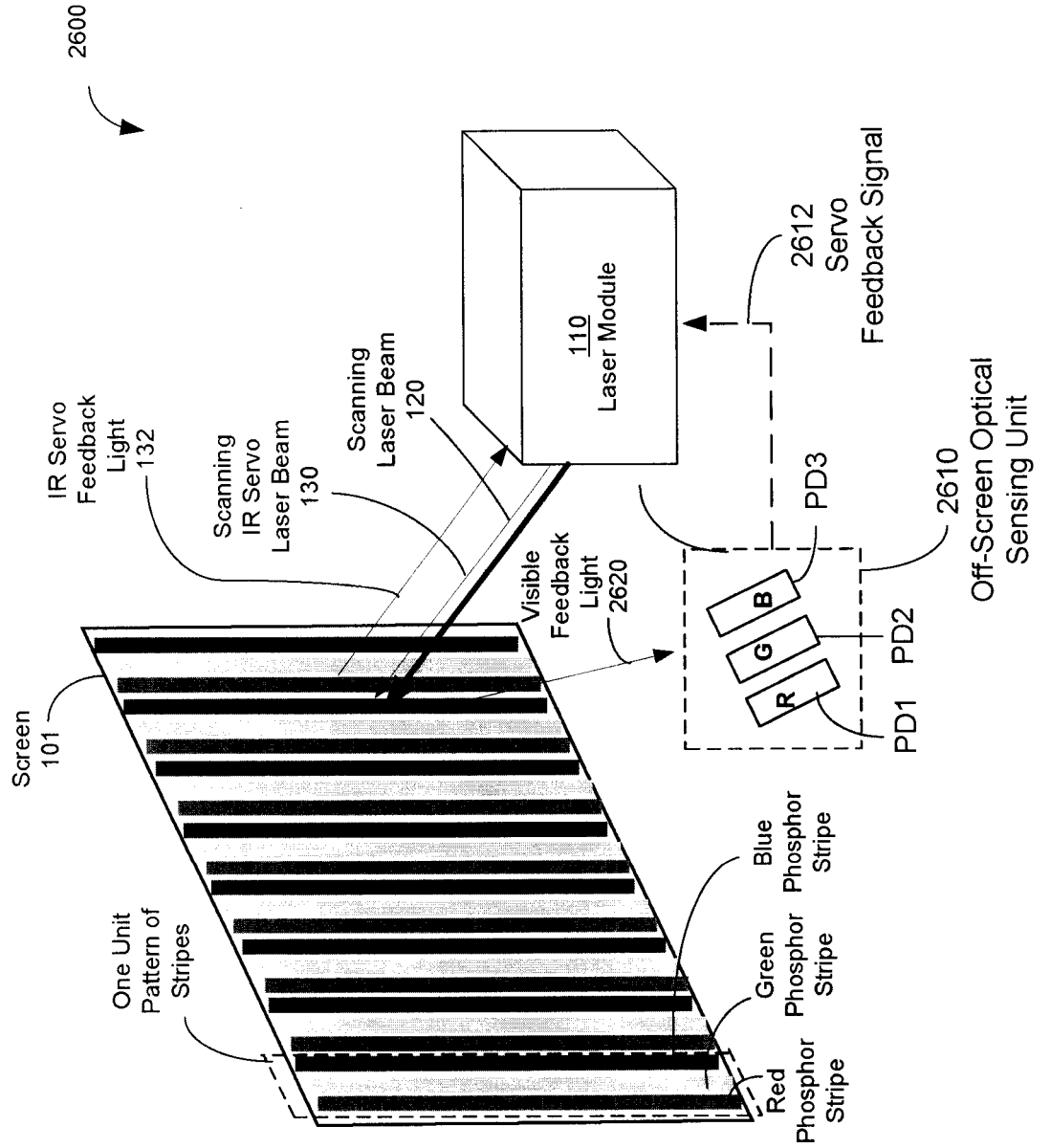


FIG. 26



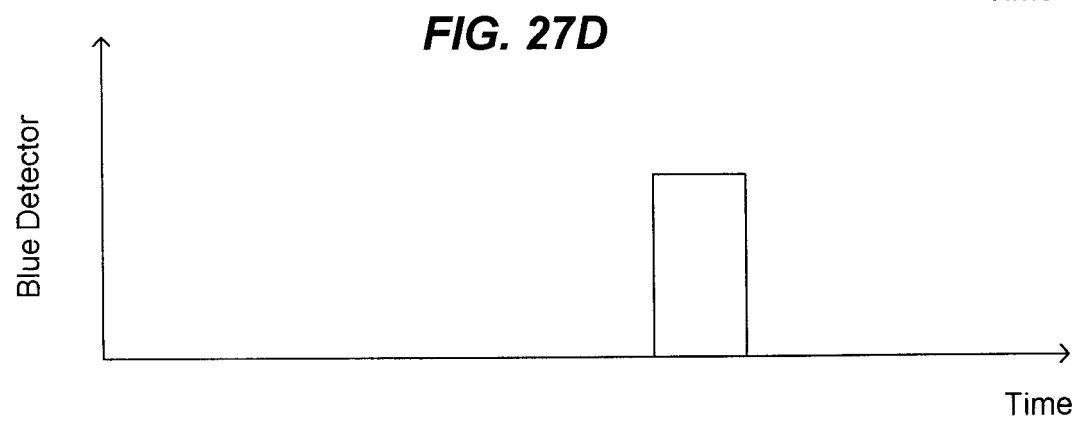
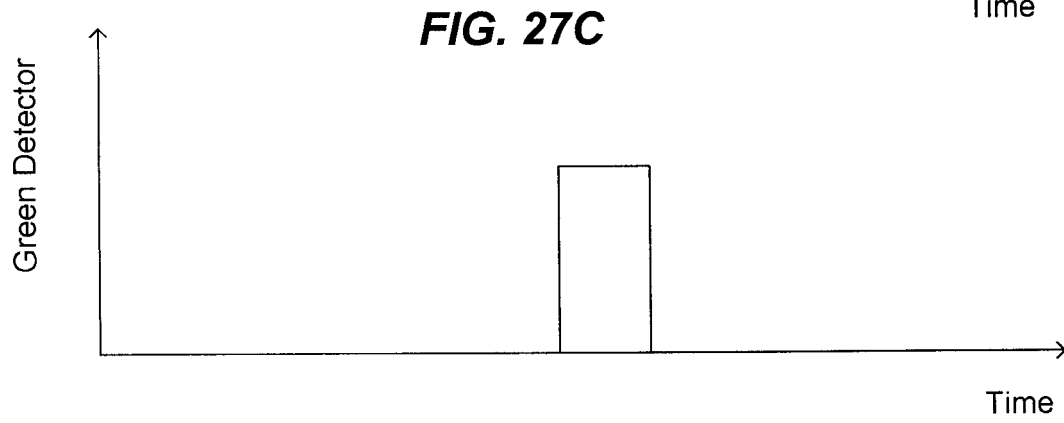
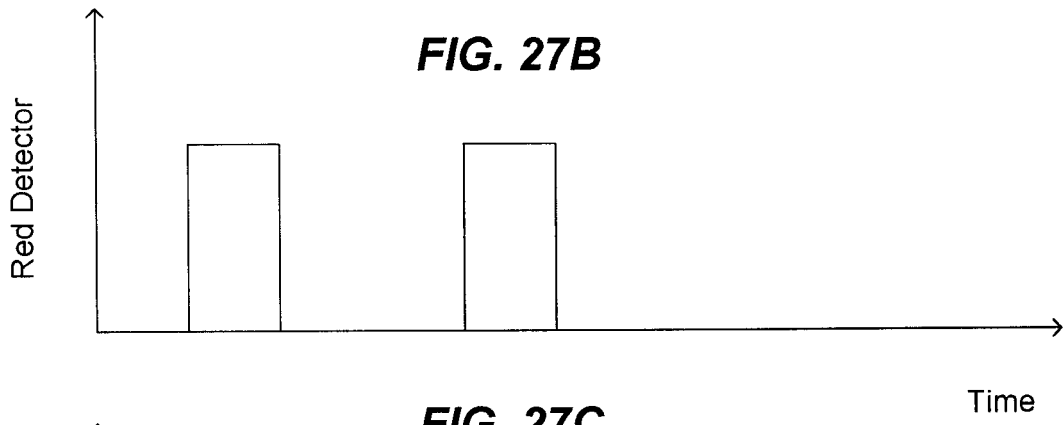
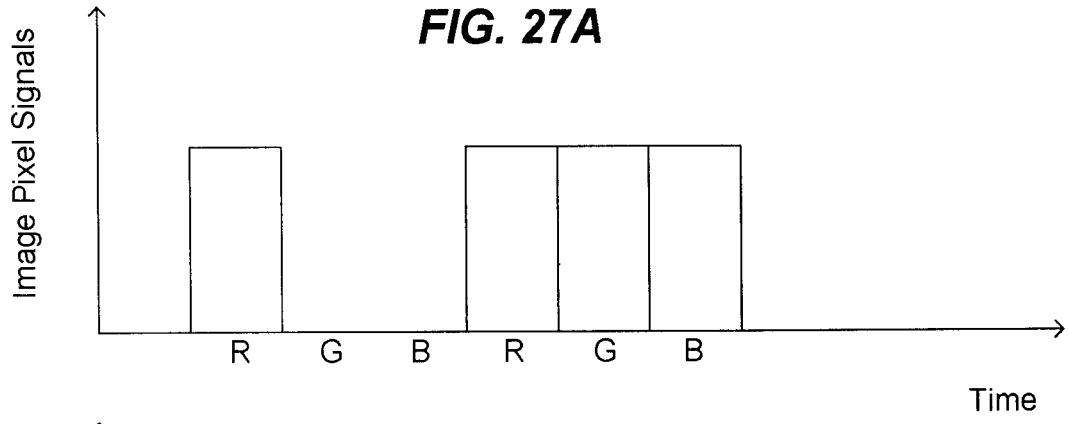
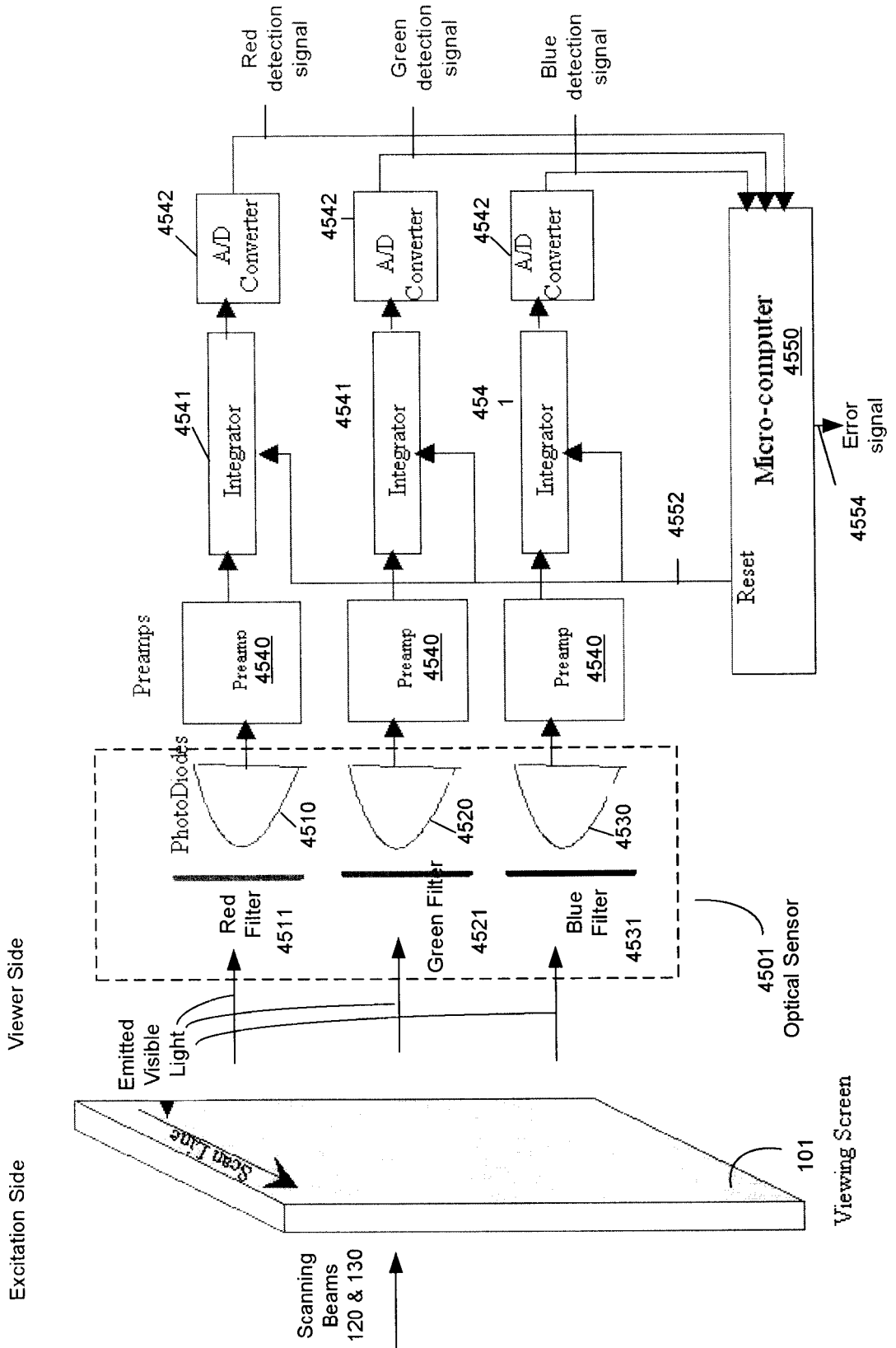


FIG. 28



**FIG. 29**

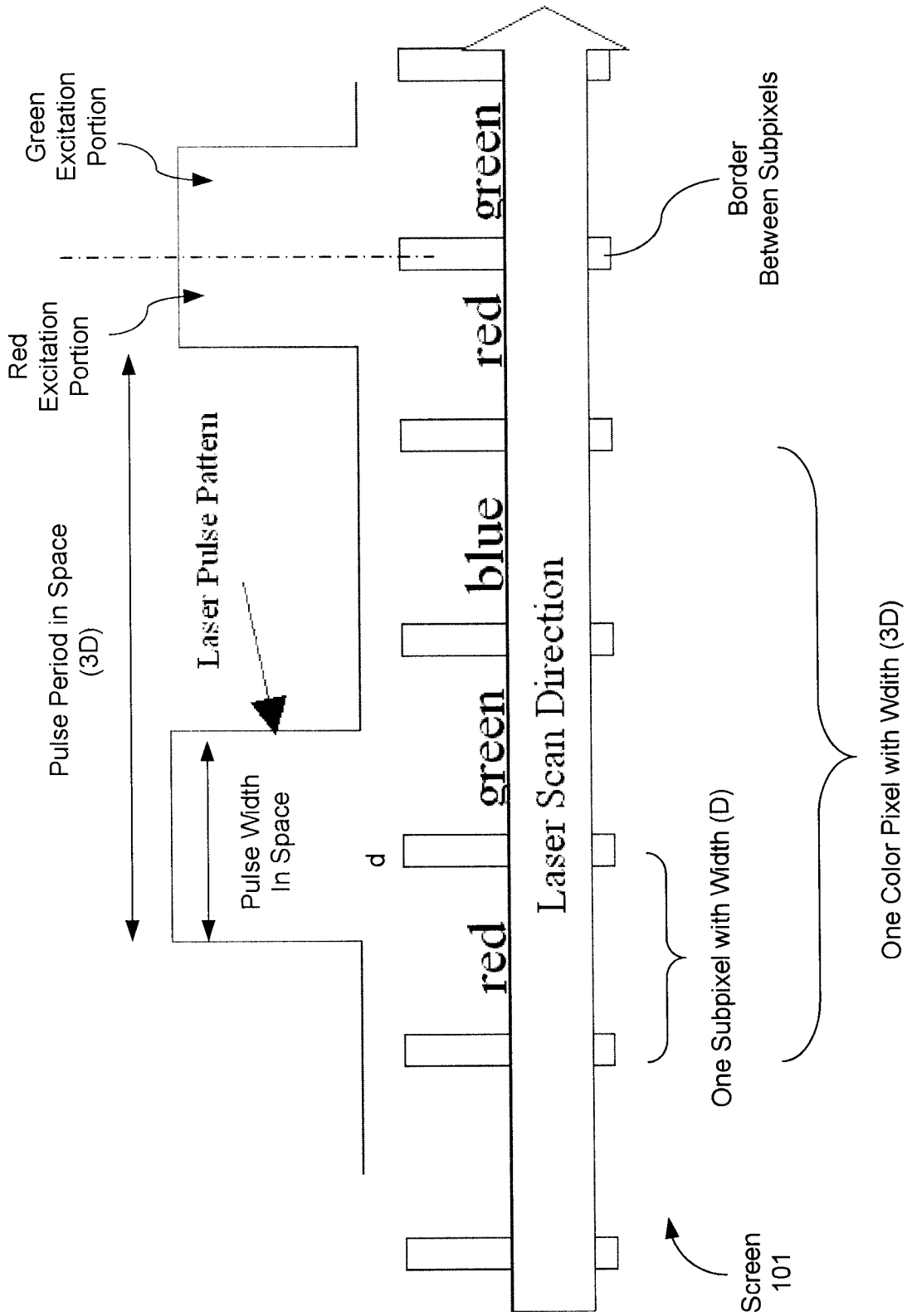


FIG. 30

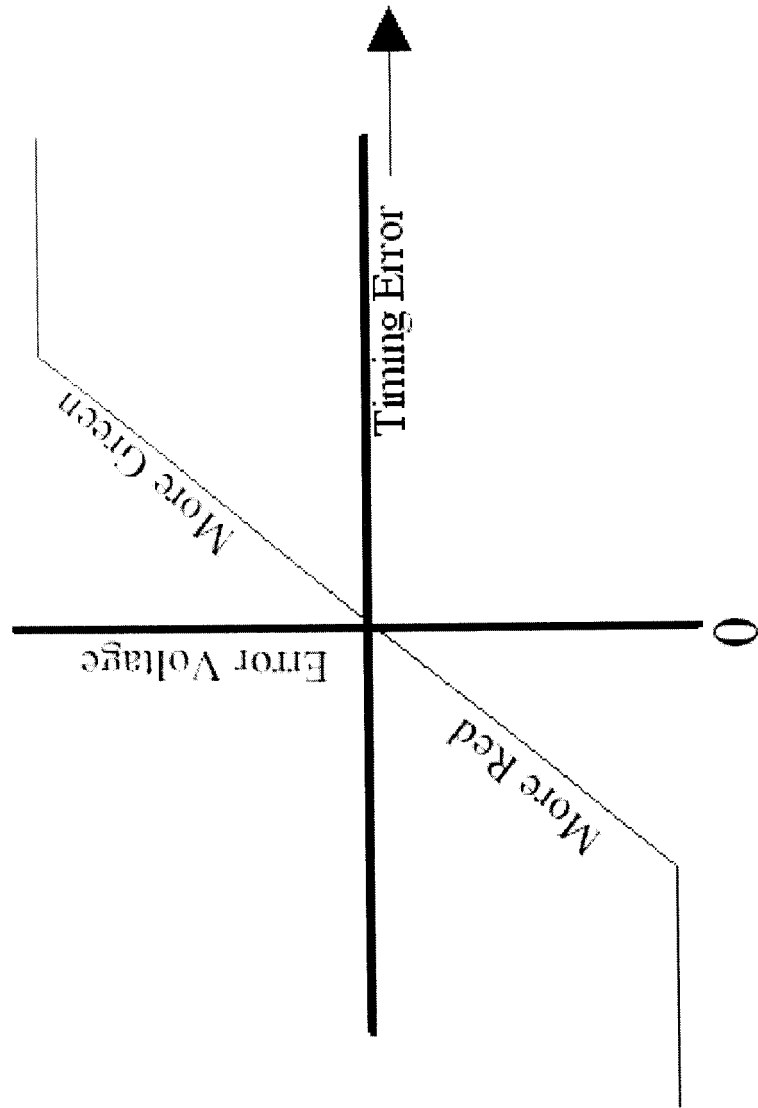
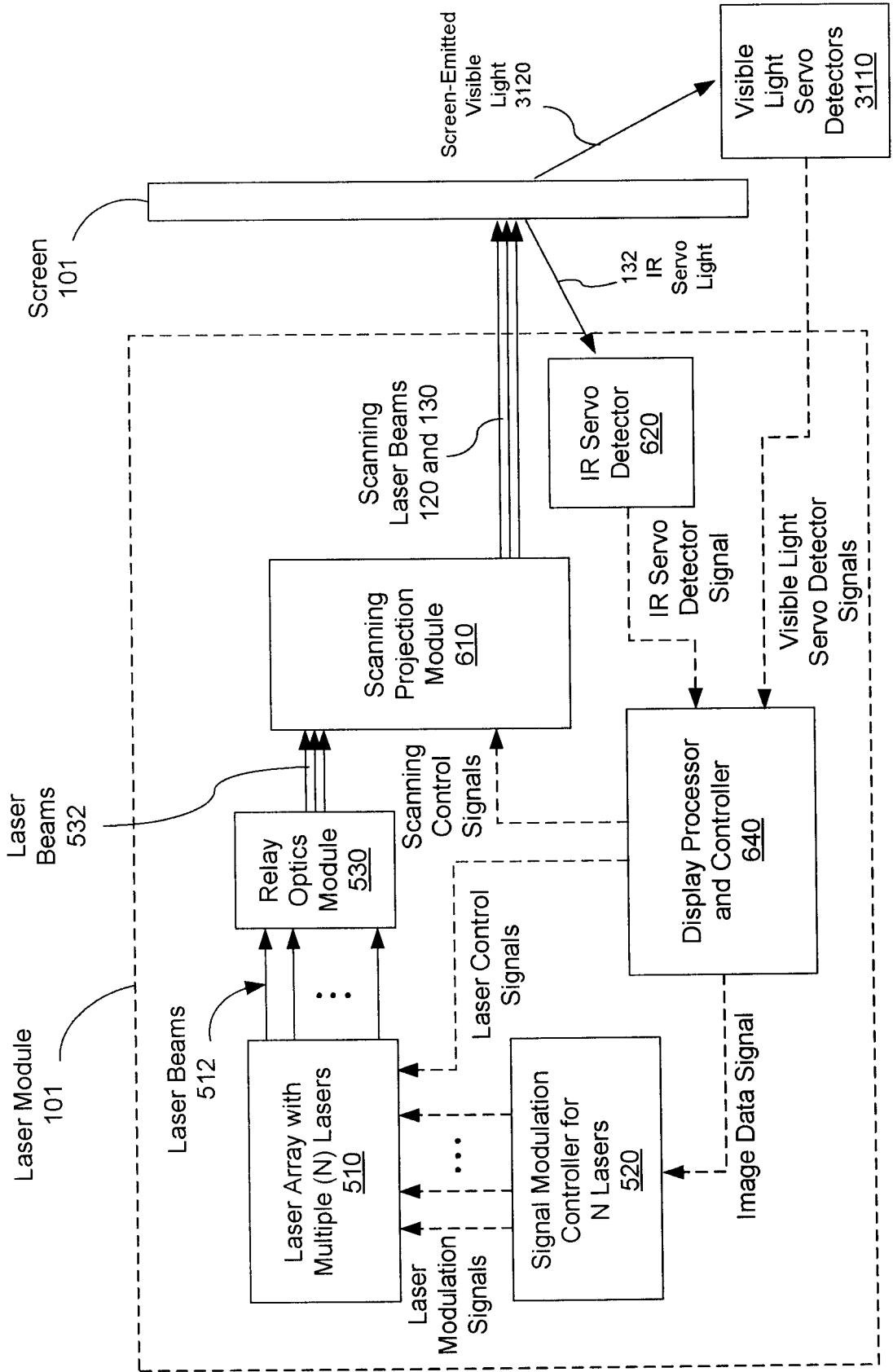


FIG. 31



## INTERNATIONAL SEARCH REPORT

International application No.  
**PCT/US2008/068679****A. CLASSIFICATION OF SUBJECT MATTER***G09G 3/02(2006.01)i, G02B 26/10(2006.01)i*

According to International Patent Classification (IPC) or to both national classification and IPC

**B. FIELDS SEARCHED**

Minimum documentation searched (classification system followed by classification symbols)

IPC 8 : G06F

Documentation searched other than minimum documentation to the extent that such documents are included in the fields searched

Korean Utility models and applications for Utility models since 1975  
Japanese Utility models and applications for Utility models since 1975

Electronic data base consulted during the international search (name of data base and, where practicable, search terms used)

eKIPASS(KIPO internal) "Keyword : display, laser beam, excitation, servo beam, scan, screen"

**C. DOCUMENTS CONSIDERED TO BE RELEVANT**

| Category* | Citation of document, with indication, where appropriate, of the relevant passages                                      | Relevant to claim No. |
|-----------|---|-----------------------|
| A         | US 2006/0221021 A1 (Roger A. Hajjar, et al.) 05 OCTOBER 2006<br>See the abstract, claims 1 and 20, figures 1 and 2.     | 1-30                  |
| A         | US 2006/0221022 A1 (Roger A. Hajjar, et al.) 05 OCTOBER 2006<br>See the abstract, claim 1, figures 1 and 2.             | 1-30                  |
| A         | US 2007/0014318 A1 (Roger A. Hajjar, et al.) 18 JANUARY 2007<br>See the abstract, claims 1, 38 and 52, figures 1 and 2. | 1-30                  |
| A         | US 2006/0082873 A1 (William J. Allen, et al.) 20 APRIL 2006<br>See paragraphs 13-17, figure 1.                          | 1-30                  |
| A         | US 2005/0094266 A1 (Jian-Qiang Liu, et al.) 05 MAY 2005<br>See paragraphs 17-19, figures 5-7.                           | 1-30                  |

 Further documents are listed in the continuation of Box C. See patent family annex.

\* Special categories of cited documents:

"A" document defining the general state of the art which is not considered to be of particular relevance

"E" earlier application or patent but published on or after the international filing date

"L" document which may throw doubts on priority claim(s) or which is cited to establish the publication date of citation or other special reason (as specified)

"O" document referring to an oral disclosure, use, exhibition or other means

"P" document published prior to the international filing date but later than the priority date claimed

"T" later document published after the international filing date or priority date and not in conflict with the application but cited to understand the principle or theory underlying the invention

"X" document of particular relevance; the claimed invention cannot be considered novel or cannot be considered to involve an inventive step when the document is taken alone

"Y" document of particular relevance; the claimed invention cannot be considered to involve an inventive step when the document is combined with one or more other such documents, such combination being obvious to a person skilled in the art

"&amp;" document member of the same patent family

Date of the actual completion of the international search

26 NOVEMBER 2008 (26.11.2008)

Date of mailing of the international search report

**26 NOVEMBER 2008 (26.11.2008)**

Name and mailing address of the ISA/KR

Korean Intellectual Property Office  
Government Complex-Daejeon, 139 Seonsa-ro, Seo-  
gu, Daejeon 302-701, Republic of Korea

Facsimile No. 82-42-472-7140

Authorized officer

CHOI, Hoon Young

Telephone No. 82-42-481-8365



**INTERNATIONAL SEARCH REPORT**

Information on patent family members

International application No.

**PCT/US2008/068679**

| Patent document<br>cited in search report | Publication<br>date | Patent family<br>member(s)  | Publication<br>date                                  |
|---|---------------------|---|--|
| US 2006/0221021 A1                        | 05.10.2006          | JP 2008-538145 A<br>KR 10-2008-0015076 A  | 09.10.2008<br>18.02.2008                             |
| US 2006/0221022 A1                        | 05.10.2006          | NONE  |  |
| US 2007/0014318 A1                        | 18.01.2007          | EP 1977413 A2<br>JP 2008-538145 A<br>KR 10-2008-0015076 A<br>KR 10-2008-0090387 A | 08.10.2008<br>09.10.2008<br>18.02.2008<br>08.10.2008 |
| US 2006/0082873 A1                        | 20.04.2006          | DE 112005002496 T5<br>WO 2006-044039 A1   | 20.09.2007<br>27.04.2006                             |
| US 2005/0094266 A1                        | 05.05.2005          | NONE  |  |

|                |  |         |            |
|----------------|--|---------|------------|
| 专利名称(译)        | 基于指定扫描伺服光束的带有发光屏的扫描光束显示系统的伺服反馈控制   |         |            |
| 公开(公告)号        | <a href="#">EP2168115A1</a>  | 公开(公告)日 | 2010-03-31 |
| 申请号            | EP2008781135   | 申请日     | 2008-06-27 |
| [标]申请(专利权)人(译) | SPUDNIK  |         |            |
| 申请(专利权)人(译)    | SPUDNIK INC.   |         |            |
| 当前申请(专利权)人(译)  | SPUDNIK INC.   |         |            |
| [标]发明人         | HAJJAR ROGER A<br>BUTLER CHRISTOPHER J<br>KENT DAVID L<br>KALUZHNY MIKHAIL         |         |            |
| 发明人            | HAJJAR, ROGER, A.<br>BUTLER, CHRISTOPHER J.<br>KENT, DAVID L.<br>KALUZHNY, MIKHAIL |         |            |
| IPC分类号         | G09G3/02 G02B26/10 G02B26/12 H04N9/31  |         |            |
| CPC分类号         | G02B26/10 G02B26/105 G02B26/127 G09G3/025 H04N9/3135                               |         |            |
| 优先权            | 11/769580 2007-06-27 US  |         |            |
| 其他公开文献         | EP2168115B1<br>EP2168115A4   |         |            |
| 外部链接           | <a href="#">Espacenet</a>  |         |            |

#### 摘要(译)

扫描光束显示系统，其将一个伺服光束和激发光束扫描到屏幕上，该屏幕在激发光的激发下发射可见光，并且基于通过反馈在屏幕上定位伺服光束来控制激发光束的光学对准控制。