



(11) **EP 1 335 436 B1**

(12) **EUROPEAN PATENT SPECIFICATION**

(45) Date of publication and mention of the grant of the patent:
25.07.2012 Bulletin 2012/30

(51) Int Cl.:
H01L 27/32 (2006.01) **G06F 3/041** (2006.01)
G06F 3/045 (2006.01) **H01L 51/56** (2006.01)

(21) Application number: **03075267.9**

(22) Date of filing: **27.01.2003**

(54) **A method for manufacturing an integrated display device including an OLED display and a touch screen**

Verfahren zur Herstellung einer integrierten Anordnung mit einem OLED-Display und einem Touchscreen

Procédé de fabrication d'un dispositif intégré comprenant un affichage de type OLED et un écran tactile

(84) Designated Contracting States:
DE FR GB

(30) Priority: **08.02.2002 US 72547**

(43) Date of publication of application:
13.08.2003 Bulletin 2003/33

(73) Proprietor: **Global OLED Technology LLC**
Herndon, VA 20171 (US)

(72) Inventors:
• **Cropper, Andre Dominic,**
c/o Eastman Kodak Company
Rochester, New York 14650-2201 (US)

• **Cok, Ronald Steven,**
c/o Eastman Kodak Company
Rochester, New York 14650-2201 (US)
• **Feldman, Rodney,**
c/o Eastman Kodak Company
Rochester, New York 14650-2201 (US)

(74) Representative: **Wibbelmann, Jobst et al**
Wuesthoff & Wuesthoff
Patent- und Rechtsanwälte
Schweigerstrasse 2
81541 München (DE)

(56) References cited:
JP-A- 2001 051 608 JP-A- 2001 076 886
JP-A- 2001 343 908

EP 1 335 436 B1

Note: Within nine months of the publication of the mention of the grant of the European patent in the European Patent Bulletin, any person may give notice to the European Patent Office of opposition to that patent, in accordance with the Implementing Regulations. Notice of opposition shall not be deemed to have been filed until the opposition fee has been paid. (Art. 99(1) European Patent Convention).

Description

[0001] The present invention relates to a method for the manufacture of resistive wire touch screens on flat-panel displays with a common substrate.

[0002] Electronic devices typically include a computing engine, a display and an interactive device responsive to the input of a user. For example, a computer may include a computing circuit, a CRT for display, and a keyboard and mouse responsive to a user's input. As a second example, a Personal Digital Assistant includes a computing circuit, an LCD display, and a touch screen formed over the LCD display, together with some buttons. Many electronic devices, in particular mobile devices, miniature devices, devices that require a reprogrammable interface, or devices that require a robust and simple user interaction mechanism, rely upon touch screens placed over a display to provide user interaction capabilities to the device.

[0003] There are many touch screen technologies such as resistive wire, acoustic, and infra-red. These are generally placed above either a CRT screen or LCD screen to provide the required interactive functionality in a single component composed of two parts. Typically, the display (for example, LCD or CRT) is manufactured while the touch screen is made separately. After the display and touch screen are manufactured, they are integrated in a common housing to provide a single component that can be built into a complete electronic device.

[0004] Resistive wire touch screens are built upon a substrate that has coated upon it a resistive film, typically indium tin oxide (ITO) at a specified thickness, uniformity and resistivity. Resistive touch screen materials, such as spacers, conductive films, etc. are carefully formed upon the coated substrate to create a resistive touch screen. When combined with a display, the multi-layer component has inferior optical characteristics to the display device alone due to inter-layer reflections, has redundant manufacturing steps, and redundant components. Moreover, the additional step of integrating the components raises manufacturing costs for the complete device. The manufacturing processes for display-and-touch-screen devices are well known in the art and products are available today from a variety of vendors. For example, US Patent 5,795,430 issued August 18, 1998 to Beeteson et al., describes an adhesive material dispensed onto a faceplate and used to attach a touch screen.

[0005] Documents JP 2001 343908, JP 2001 076886 and JP 2001 051608 disclose the integration of a display and a touch screen. Manufacture methods thereof are also disclosed.

[0006] A new class of display devices based upon organic light-emitting diodes (OLEDs) is formed by depositing patterned conductive and organic materials upon a substrate. This substrate can be identical to the substrate used for resistive wire touch screens. Moreover, some of the materials used for the patterned conductive materials are similar to, or the same as, those used for the

resistive films, but their uniformity, thickness and resistivity may vary. Passive matrix OLED displays are made by patterning a conductive material that is formed on a substrate. Active matrix OLED displays are typically made by patterning a conductive material on semiconducting materials comprising thin film transistor (TFT) circuitry. The TFTs are formed on a substrate. For an OLED display, the conductive material is ideally a low resistivity film, whereas for a touch screen a controlled higher resistivity film is employed. Once the conductive pattern is formed, organic materials are deposited, followed by any remaining conductive elements, planarization layers and other layers as known in the prior art. Connecting pads are defined as part of the conducting pattern and are wire-bonded to a cable after the device is encapsulated. The process by which the OLED display device is made uses well-known photo-lithographic, deposition, bonding, and encapsulation methods common-place in the integrated circuit industry. However, a problem exists with the conventional practice of forming separate OLED displays and touch screens and then combining them with a conventional mount, in that the additional layers in the touch screen reduce the brightness of the display, reduces the optical quality of the display due to additional internal reflections from the layers of the touch screen, and add cost due to the need for two substrates and a complex housing for the two elements..

[0007] There is a need therefore for an improved method for manufacturing an integrated resistive touch screen and OLED display that reduces redundant components in the devices, reduces cost, improves optical qualities, and is more robust.

[0008] The need is met according to the present invention by providing a method of manufacturing a display device having two components, an OLED display formed on a film on one side of a substrate and a touch screen formed on a film on the other side of the substrate, the OLED display including components that are sensitive to high temperatures, that includes the steps of: partially forming one of the components on one side of the substrate; applying a protector over the partially constructed component; forming the other component of the display device on the other side of the substrate; removing the protector; and completing the formation of the one component on the one side of the substrate.

[0009] The present invention has the advantage that it reduces the number of components required to build an integrated OLED display and resistive touch screen device, reduces the number of manufacturing steps, reduces the manufacturing costs, reduces the combined size of the display and touch screen device, and provides superior optical performance.

Fig. 1 is a schematic side view of an integrated display device that can be manufactured according to the present invention;

Fig. 2 is a flow chart showing the manufacturing steps of the present invention; and

Fig. 3 is a schematic side view of a protector employed according to one embodiment of the present invention.

[0010] Referring to Fig. 1, a substrate **100** (typically glass or rigid polymer) having two parallel flat sides is used both for an OLED display **102** and a resistive touch screen **104**. The OLED display **102** emits light through the substrate **100** and the resistive touch screen **104**. The OLED display **102** is formed on a conductive film **110** that is patterned to provide conductors as is known in the art. For passive matrix OLED displays, the conductive film is formed directly on substrate **100**. For active matrix OLED displays, the conductive film is formed on thin film transistor (TFT) circuitry, where the TFT circuitry was previously formed on the substrate **100**. The resistive touch screen **104** is formed on a uniform resistive film **112** as is known in the art. As used herein conductive film refers to a film that will be subsequently patterned to form conductors in an OLED device and resistive film refers to a film that will be employed in a resistive touch screen. It will be understood that the conductive and resistive films may be similar materials formed by similar methods, with the materials or forming methods being varied to produce higher or lower conductivity in the films as required by the application. Connectors **106** and **108** are provided to the OLED display **102** and touch-screen **104** respectively for driving the display and receiving inputs from an operator of the display.

[0011] Conventionally, the resistive/conductive film, usually indium tin oxide (ITO), is formed using a high temperature (e.g. 200° C and higher). If OLED materials are subjected to such high temperatures, their performance (life time, stability, color characteristics) can be adversely affected. Thus, it is preferable that any high temperature resistive/conductive film deposition steps be performed prior to the deposition of any OLED materials. In making a flat panel display and a touch screen on a common substrate, one possible approach is to perform the high temperature deposition steps for both the OLED display and the touch screen prior to deposition of the OLED materials. Unfortunately, conventional handling equipment used to manufacture OLED flat panel displays and touch screens contact the substrate from the back side, potentially causing damage to any previously formed resistive film layers. Furthermore, if an entire touch screen were to have been previously formed on one side of the substrate, the handling equipment used to make the OLED display would not function properly.

[0012] Referring to Fig. 2, according to one embodiment of the present invention, a clean transparent substrate having two parallel sides is provided **10**. A resistive film is formed **12** on a first side of the substrate using any conventional technique, including but not limited to, high temperature sputtering. Next, a protector, such as a layer of silicon dioxide or photoresist is applied **14** over the resistive film on the first side of the substrate. Referring to Fig. 3, alternatively, a thin, flat protective device **114**

having similar properties to the substrate may be affixed to the substrate **100** over the resistive layer **112** with a removable adhesive to protect it. For example, a reusable glass cover plate with a cavity **116** provided on one side may be used to protect the resistive material.

[0013] Returning to Fig. 2, an OLED display is then formed **16** on the opposite side of the substrate. Since OLED materials have not yet been deposited on the substrate, the conventional process of forming the OLED display can be employed. For passive matrix devices a conductive ITO film is deposited using a high temperature sputtering technique. For active matrix devices, semiconducting materials are formed and patterned on the OLED display side of the substrate, followed by a conductive ITO film using a high temperature sputtering technique. After the conductive ITO film is formed, for either passive or active matrix OLEDs, the OLED materials are deposited and patterned using low temperature techniques. Once the OLED display is completed, the protector is removed **18** and the touch screen **104** is completed **20** over the resistive layer **112**.

[0014] Alternatively, the conductive film for passive matrix OLED displays may be formed first and protected; the touch sensitive screen formed on the other side, the protector removed; and finally the OLED display completed.

[0015] According to a further alternative embodiment of the present invention, the conductive film for a passive matrix OLED display is first formed and patterned, and all subsequent steps prior to deposition of the organic materials are completed. The protector is then applied over the partially completed OLED display. The touch sensitive screen is then formed on the other side of the substrate, including the deposition of a resistive film. The protector is then removed and the OLED display is completed.

[0016] According to a further alternative embodiment of the present invention, the thin film transistor circuitry and the conductive film for an active matrix OLED display are first formed and patterned, and all subsequent steps prior to deposition of the organic materials are completed. The protector is then applied over the partially completed OLED display. The touch sensitive screen is then formed on the other side of the substrate, including the deposition of a resistive film. The protector is then removed and the OLED display is completed.

Claims

1. A method of manufacturing a display device having two components, an OLED display (102) formed on a film on one side of a substrate (106) and a touch screen (104) formed on a film on the other side of the substrate, the OLED display including components that are sensitive to high temperatures, comprising the steps of:

- a) partially forming one of the components on one side of the substrate (12);
 b) applying a protector over the partially constructed component (14);
 c) forming the other component of the display device on the other side of the substrate (16);
 d) removing the protector (18); and
 e) completing the formation of the one component on the one side of the substrate (20).
2. The method claimed in claim 1, wherein the one component is the OLED display.
3. The method claimed in claim 2, wherein the step of partially forming comprises the step of forming a conductive film.
4. The method claimed in claim 3, wherein the step of forming a film is a low temperature sputtering process.
5. The method claimed in claim 3, wherein the conductive film is indium tin oxide (ITO).
6. The method claimed in claim 3, wherein the step of forming a film is a high temperature sputtering process.
7. The method claimed in claim 1, wherein the step of partially forming comprises all of the steps necessary to form the OLED display up to the step of depositing the OLED materials.
8. The method claimed in claim 1, wherein the one component is the touch screen.
9. The method claimed in claim 8, wherein the step of partially forming the touch screen comprises the step of forming a resistive film.
10. The method claimed in claim 9, wherein the film is ITO.
11. The method claimed in claim 9, wherein the step of forming a film is a high temperature sputtering process.
12. The method claimed in claim 9, wherein the step of forming a film is a low temperature sputtering process.
13. The method claimed in claim 12, wherein the film is ITO.
14. The method claimed in claim 1 wherein the OLED display device is a passive-matrix OLED display device.
15. The method claimed in claim 1 wherein the OLED display device is an active-matrix OLED display device.
16. The method claimed in claim 1, wherein the protector is a layer of silicon dioxide.
17. The method claimed in claim 1, wherein the protector is a layer of photo-resist.
18. The method claimed in claim 1, wherein the protector is a cover plate defining a cavity.
19. The method claimed in claim 2, wherein the OLED display is an active matrix OLED display.
20. The method claimed in claim 19, wherein the step of partially forming comprises the step of forming thin film transistor circuitry and a conductive film.
21. The method claimed in claim 20, wherein the step of partially forming further comprises all of the steps necessary to form the OLED display up to the step of depositing the OLED materials.

Patentansprüche

1. Verfahren zur Herstellung einer Anzeigevorrichtung mit zwei Komponenten, einer OLED-Anzeigeeinrichtung (102), die auf einem Film auf einer Seite eines Substrats (106) gebildet ist, und einem berührungsempfindlichen Bildschirm (104), der auf einem Film auf der anderen Seite des Substrats gebildet ist, wobei die OLED-Anzeigeeinrichtung Komponenten einschließt, die gegen hohe Temperaturen empfindlich sind, umfassend die Schritte:
- a) teilweises Bilden einer der Komponenten auf einer Seite des Substrats (12);
 b) Aufbringen eines Schutzes über der teilweise aufgebauten Komponente (14);
 c) Bilden der anderen Komponente der Anzeigevorrichtung auf der anderen Seite des Substrats (16);
 d) Entfernen des Schutzes (18); und
 e) Vervollständigen der Bildung der einen Komponente auf der einen Seite des Substrats (20).
2. Verfahren nach Anspruch 1, bei dem die eine Komponente die OLED-Anzeigeeinrichtung ist.
3. Verfahren nach Anspruch 2, bei dem der Schritt des teilweisen Bildens den Schritt der Bildung eines leitfähigen Films umfasst.
4. Verfahren nach Anspruch 3, bei dem der Schritt der Bildung eines Films ein Niedertemperatur-Sputter-

- Prozess ist.
5. Verfahren nach Anspruch 3, bei dem der leitfähige Film Indiumzinnoxid (ITO) ist.
 6. Verfahren nach Anspruch 3, bei dem der Schritt der Bildung eines Films ein Hochtemperatur-Sputter-Prozess ist.
 7. Verfahren nach Anspruch 1, bei dem der Schritt der teilweisen Bildung alle Schritte umfasst, die erforderlich sind, um die OLED-Anzeigevorrichtung bis zum Schritt der Abscheidung der OLED-Materialien zu bilden.
 8. Verfahren nach Anspruch 1, bei dem die eine Komponente der berührungsempfindliche Bildschirm ist.
 9. Verfahren nach Anspruch 8, bei dem der Schritt des teilweisen Bildens des berührungsempfindlichen Bildschirms den Schritt der Bildung eines resistiven Films umfasst.
 10. Verfahren nach Anspruch 9, bei dem der Film ITO ist.
 11. Verfahren nach Anspruch 9, bei dem der Schritt der Bildung eines Films ein Hochtemperatur-Sputter-Prozess ist.
 12. Verfahren nach Anspruch 9, bei dem der Schritt der Bildung eines Films ein Niedertemperatur-Sputter-Prozess ist.
 13. Verfahren nach Anspruch 12, bei dem der Film ITO ist.
 14. Verfahren nach Anspruch 1, bei dem die OLED-Anzeigevorrichtung eine OLED-Anzeigevorrichtung mit passiver Matrix ist.
 15. Verfahren nach Anspruch 1, bei dem die OLED-Anzeigevorrichtung eine OLED-Anzeigevorrichtung mit aktiver Matrix ist.
 16. Verfahren nach Anspruch 1, bei dem der Schutz eine Schicht aus Siliciumdioxid ist.
 17. Verfahren nach Anspruch 1, bei dem der Schutz eine Schicht aus Photoresist ist.
 18. Verfahren nach Anspruch 1, bei dem der Schutz eine Deckplatte ist, die einen Hohlraum begrenzt.
 19. Verfahren nach Anspruch 2, bei dem die OLED-Anzeigeeinrichtung eine OLED-Anzeigeeinrichtung mit aktiver Matrix ist.
 20. Verfahren nach Anspruch 19, bei dem der Schritt

des teilweisen Bildens den Schritt der Bildung eines Dünnschichttransistor-Schaltkreises und eines leitfähigen Films umfasst.

- 5 21. Verfahren nach Anspruch 20, bei dem der Schritt des teilweisen Bildens weiter alle Schritte umfasst, die erforderlich sind, um die OLED-Einrichtung bis zum Schritt der Abscheidung der OLED-Materialien zu bilden.

10

Revendications

- 15 1. Procédé de fabrication d'un dispositif d'affichage comportant deux composants, un affichage de type OLED (102) formé sur un film sur un côté d'un substrat (106) et un écran tactile (104) formé sur un film de l'autre côté du substrat, l'affichage de type OLED comprenant des composants qui sont sensibles aux hautes températures, comprenant les étapes consistant à :

20

- a) former partiellement l'un des composants sur un côté du substrat (12) ;
- b) appliquer une protection sur le composant partiellement construit (14) ;
- c) former l'autre composant du dispositif d'affichage sur l'autre côté du substrat (16) ;
- d) enlever la protection (18) ; et
- e) achever la formation du composant sur l'autre côté du substrat (20).

25

2. Procédé selon la revendication 1, dans lequel le composant est l'affichage de type OLED.

35

3. Procédé selon la revendication 2, dans lequel l'étape de formation partielle comprend l'étape consistant à former un film conducteur.

40

4. Procédé selon la revendication 3, dans lequel l'étape de formation d'un film est un procédé de pulvérisation à basse température.

45

5. Procédé selon la revendication 3, dans lequel le film conducteur est un film d'oxyde d'étain et d'indium (ITO).

50

6. Procédé selon la revendication 3, dans lequel l'étape de formation d'un film est un procédé de pulvérisation à haute température.

55

7. Procédé selon la revendication 1, dans lequel l'étape de formation partielle comprend toutes les étapes nécessaires pour former l'affichage de type OLED jusqu'à l'étape de dépôt des matériaux OLED.

8. Procédé selon la revendication 1, dans lequel le composant est l'écran tactile.

9. Procédé selon la revendication 8, dans lequel l'étape de formation partielle de l'écran tactile comprend l'étape consistant à former un film résistif.
10. Procédé selon la revendication 9, dans lequel le film est un film d'oxyde d'étain et d'indium (ITO). 5
11. Procédé selon la revendication 9, dans lequel l'étape de formation d'un film est un procédé de pulvérisation à haute température. 10
12. Procédé selon la revendication 9, dans lequel l'étape de formation d'un film est un procédé de pulvérisation à basse température. 15
13. Procédé selon la revendication 12, dans lequel le film est un film d'oxyde d'étain et d'indium (ITO).
14. Procédé selon la revendication 1, dans lequel le dispositif d'affichage de type OLED est un dispositif d'affichage de type OLED à matrice passive. 20
15. Procédé selon la revendication 1, dans lequel le dispositif d'affichage de type OLED est un dispositif d'affichage de type OLED à matrice active. 25
16. Procédé selon la revendication 1, dans lequel la protection est une couche de dioxyde de silicium.
17. Procédé selon la revendication 1, dans lequel la protection et une résine photosensible. 30
18. Procédé selon la revendication 1, dans lequel la protection est une plaque de couverture définissant une cavité. 35
19. Procédé selon la revendication 2, dans lequel l'affichage de type OLED est un affichage de type OLED à matrice active. 40
20. Procédé selon la revendication 19, dans lequel l'étape de formation partielle comprend l'étape consistant à former un montage de transistor à couches minces et un film conducteur. 45
21. Procédé selon la revendication 20, dans lequel l'étape de formation partielle comprend en outre toutes les étapes nécessaires pour former l'affichage de type OLED jusqu'à l'étape de dépôt des matériaux OLED. 50

55

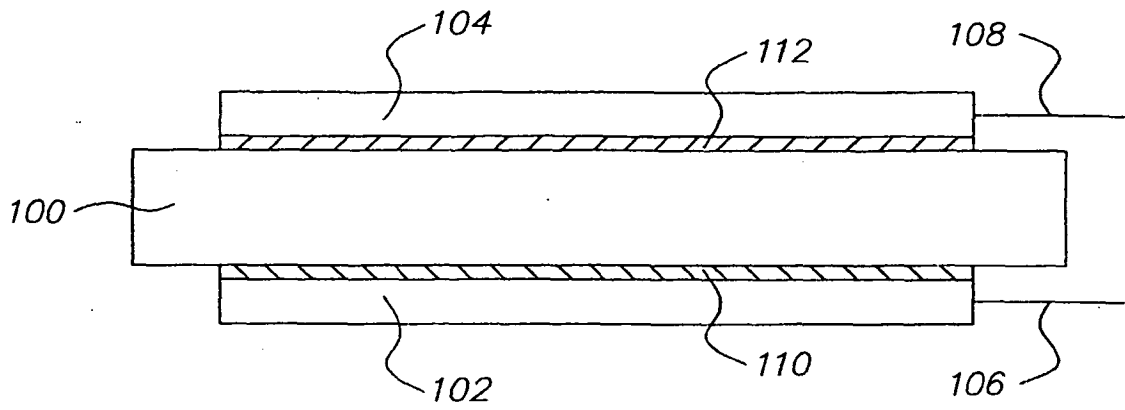

FIG. 1

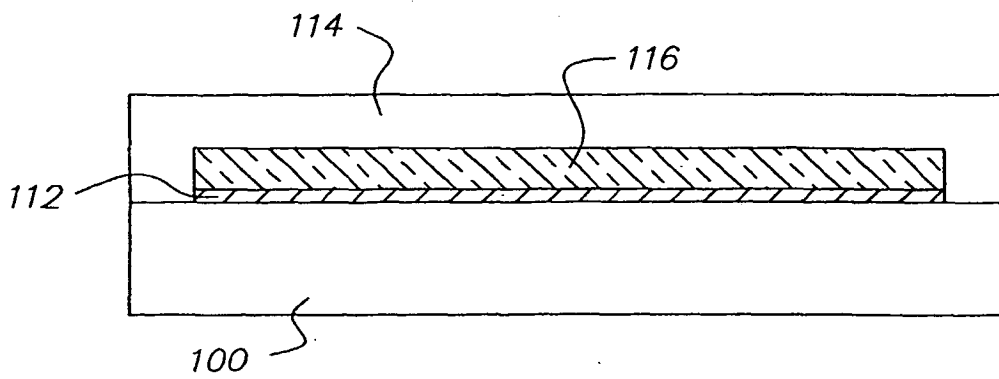

FIG. 3

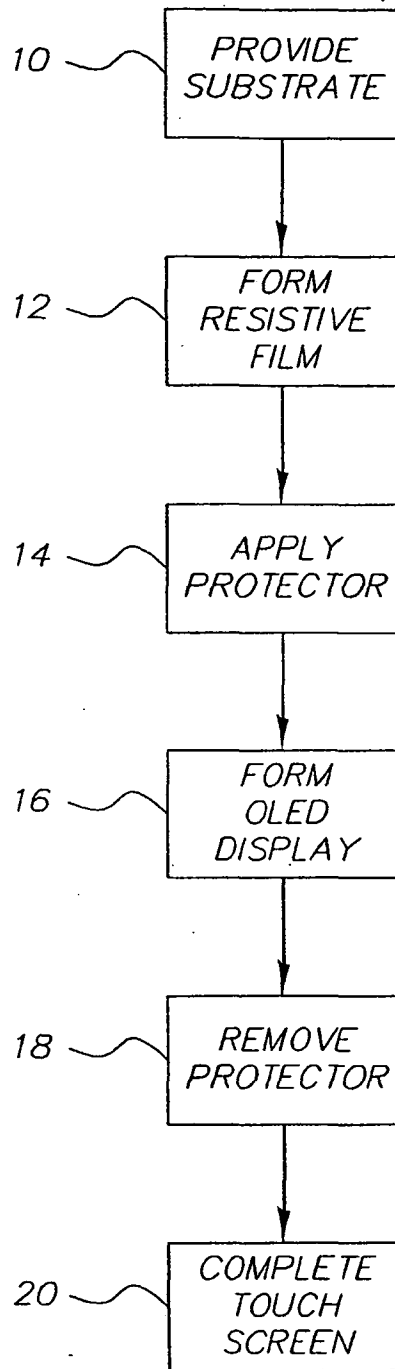

FIG. 2

REFERENCES CITED IN THE DESCRIPTION

This list of references cited by the applicant is for the reader's convenience only. It does not form part of the European patent document. Even though great care has been taken in compiling the references, errors or omissions cannot be excluded and the EPO disclaims all liability in this regard.

Patent documents cited in the description

- US 5795430 A, Beeteson [0004]
- JP 2001343908 A [0005]
- JP 2001076886 A [0005]
- JP 2001051608 A [0005]

专利名称(译)	一种用于制造包括OLED显示器和触摸屏的集成显示装置的方法		
公开(公告)号	EP1335436B1	公开(公告)日	2012-07-25
申请号	EP2003075267	申请日	2003-01-27
[标]申请(专利权)人(译)	伊斯曼柯达公司		
申请(专利权)人(译)	伊士曼柯达公司		
当前申请(专利权)人(译)	全球OLED科技有限责任公司		
[标]发明人	COK RONALD STEVEN C O EASTMAN KODAK COMPANY		
发明人	CROPPER, ANDRE DOMINIC, C/O EASTMAN KODAK COMPANY COK, RONALD STEVEN, C/O EASTMAN KODAK COMPANY FELDMAN, RODNEY, C/O EASTMAN KODAK COMPANY		
IPC分类号	H01L27/32 G06F3/041 G06F3/045 H01L51/56 H05B33/10 G06F3/033 H01L51/50		
CPC分类号	G06F3/045 G06F3/041 H01L27/323 H01L27/3244 H01L51/56 Y10T428/10		
优先权	10/072547 2002-02-08 US		
其他公开文献	EP1335436A2 EP1335436A3		
外部链接	Espacenet		

摘要(译)

一种制造显示装置的方法，所述显示装置具有两个部件，OLED显示器形成在基板一侧上的膜上，触摸屏形成在基板另一侧上的膜上，所述OLED显示器包括对高敏感的部位温度包括以下步骤：在基板的一侧部分地形成一个部件；在部分构造的部件上施加保护器；在基板的另一侧形成显示装置的另一个部件；取下保护器；并完成在基板一侧上形成一个组件。

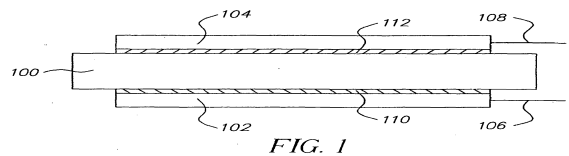

FIG. 1

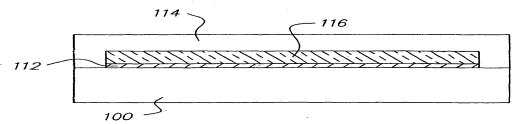

FIG. 3