



(12) **EUROPEAN PATENT APPLICATION**
 published in accordance with Art. 158(3) EPC

- (43) Date of publication: **19.12.2001 Bulletin 2001/51**
- (21) Application number: **00956893.2**
- (22) Date of filing: **04.09.2000**
- (51) Int Cl.7: **G09G 3/30, H03F 3/34, G06F 3/08**
- (86) International application number: **PCT/JP00/05978**
- (87) International publication number: **WO 01/29813 (26.04.2001 Gazette 2001/17)**

(84) Designated Contracting States:
DE FR GB NL
 Designated Extension States:
AL LT LV MK RO SI

(30) Priority: **20.10.1999 JP 29759399**
27.06.2000 JP 2000192023

(71) Applicant: **TDK Corporation**
Chuo-ku, Tokyo 103-8272 (JP)

(72) Inventors:
 • **FURUKAWA, Hirotada**
Tokyo 103-8272 (JP)
 • **SAITOH, Yoshihiro**
Tokyo 103-8272 (JP)

(74) Representative:
Grünecker, Kinkeldey, Stockmair &
Schwanhäusser Anwaltssozietät
Maximilianstrasse 58
80538 München (DE)

(54) **CONSTANT-CURRENT DEVICE, DISPLAY DEVICE, AND METHOD FOR DRIVING THE SAME**

(57) An object of the invention is to suppress a delay in rising of drive voltage when a light-emitting element to be a capacitive load is driven while preventing an increase in circuit size. A display apparatus comprises: an organic EL display (1) including organic EL elements as light-emitting elements; a scanning electrode drive circuit (2) for driving scanning electrodes of the display (1); and a data electrode drive section (3) for driving data electrodes of the display (1). The data electrode drive section (3) includes constant current circuits for the respective data electrodes, each of the constant current circuits supplying a constant current to each of the data electrodes. Each of the constant current circuits allows the value of constant current outputted to change in response to the reference value given such as a reference voltage. The reference value is switched such that, with regard to the period for which one of the scanning electrodes is selected, the value of the constant current supplied to one of the organic EL elements for a specific period started at the point at which the current starts to be supplied is greater than the value of the constant current supplied to the EL element for the remaining period.

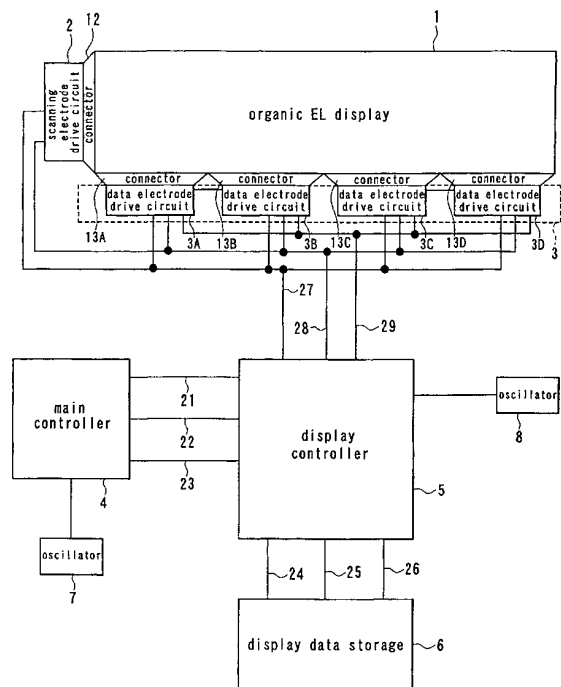

FIG. 1

Description

TECHNICAL FIELD

[0001] The present invention relates to a constant current apparatus used for driving a capacitive load, for example, a display apparatus for driving light-emitting elements by supplying constant currents thereto, and a method of driving such a display apparatus.

BACKGROUND ART

[0002] Organic electroluminescent (EL) elements have been increasingly developed and brought to practical utilization. Organic EL elements are charge-injection recombination EL elements including an organic material as a luminescent material. Considerable research and development activities have been done on display apparatuses incorporating displays made up of organic EL elements arranged in segments or a matrix or a combination thereof, with a view to achieving practical utilization and performance improvements of such display apparatuses as next-generation displays having features such as low profile, high luminance, a wide viewing angle, and high definition.

[0003] Displays incorporating organic EL elements have started to be practically utilized as monochrome displays of constant luminance.

Practical utilization of color displays is expected, such as partial color displays whose display surface is made up of partially different luminescent colors, multicolor displays that emit several colors, and full color displays that combine multicolor luminescence and tone control.

[0004] The organic EL element has a structure that, for example, a hole injection layer and a hole migration layer that are made of organic or inorganic substance, a light-emitting layer made of organic substance, and an electron migration layer made of organic or inorganic substance are stacked, as necessary, between electrodes (electron injection electrodes) of aluminum, for example, and transparent electrodes (hole injection electrodes) made of tin-doped indium oxide (ITO), for example, arranged in a matrix or segments on a glass substrate.

[0005] Since the luminance intensity of the organic EL element is proportional to the density of current fed to the element, an organic EL display is preferably current-driven. However, the organic EL element is a capacitive load since it is made up of layers of organic materials stacked between the electrodes. Therefore, if the organic EL display is driven by a constant current, rising of voltage driving the EL element may delay during a period in which a charging current is fed to the capacitive component of the EL element when the element is driven. A delay in light emission may thereby result.

[0006] Reference is now made to FIG. 15 to describe the cause of the above-mentioned phenomenon. FIG. 15 (a) shows the waveform of current supplied to the

capacitive load from a constant current source. FIG. 15 (b) shows the waveform of voltage across the capacitive load when the current having the waveform of (a) is supplied. When the capacitive load such as an organic EL element is driven by a constant current source, the constant current source supplies a constant current to the load, the current including a charging current to the capacitive load. Therefore, the value of the current supplied to the capacitive load is a constant value I_0 , as shown in FIG. 15 (a). In this case, the rising edge of the voltage across the capacitive load is blunt during the period in which the charging current fed to the capacitive load exists, as shown in FIG. 15 (b). A steady state having been achieved, the value of the voltage across the capacitive load is a constant value V_0 .

[0007] In Published Unexamined Japanese Patent Application Hei 11-95723 (1999), a technique relating to a display apparatus including a display made up of organic EL elements arranged in a matrix is disclosed. According to this technique, immediately before a specific unit electrode of data electrodes is selected, all the scanning electrodes and all the data electrodes (or a specific one of the data electrodes) are shorted so that these electrodes are reset to the same potential. A delay in light emission is thereby reduced.

[0008] According to this technique, however, switches for resetting the respective unit electrodes are required, and the size of the drive circuit is thereby increased particularly when the display includes a large number of data electrodes.

[0009] According to this technique, if the organic EL display is driven by a constant current, a charging current is fed to the data electrode connected to the EL element to be illuminated, immediately after resetting. It is therefore impossible to suppress a delay in light emission caused by this charging current.

[0010] According to a technique disclosed in Published Unexamined Japanese Patent Application Hei 11-231834 (1999), a first drive source and a second drive source that are connectable to light-emitting elements are provided. To drive the light-emitting elements, the first drive source first supplies drive currents to the elements, and the second drive source then supplies drive currents to the elements. The drive currents fed by the first drive source are greater than those fed by the second drive source.

[0011] According to this technique, however, two drive sources are required for each data electrode, and the size of the drive circuit is thereby increased particularly when the display includes a large number of data electrodes.

DISCLOSURE OF THE INVENTION

[0012] It is a first object of the invention to provide a constant current apparatus for suppressing a delay in rising of drive current when a capacitive load is driven, too, while preventing an increase in circuit size.

[0013] It is a second object of the invention to provide a display apparatus and a method of driving the same for suppressing a delay in rising of drive current when a light-emitting element to be a capacitive load is driven, too, while preventing an increase in circuit size.

[0014] A constant current apparatus of the invention comprises: a constant current circuit for outputting a constant current determined by a reference value given; and a reference value selecting means for selecting one of a plurality of reference values and giving the value selected to the constant current circuit.

[0015] According to the constant current apparatus of the invention, when the capacitive load is driven, the reference value selecting means is controlled such that, with regard to the period for which a current is fed to the capacitive load, the value of the constant current supplied to the capacitive load for a specific period started at the point at which the current starts to be supplied is greater than the value of the constant current supplied to the capacitive load for the remaining period. A delay in rising of drive voltage is thereby suppressed.

[0016] According to the constant current apparatus of the invention, the reference values may be any of reference voltages, reference currents and reference resistance values. The constant current apparatus of the invention is used for driving a capacitive load, for example.

[0017] A display apparatus of the invention comprises: a display including a plurality of light-emitting elements; and a drive means for driving the light-emitting elements by selectively supplying power required for light emission to the elements. The drive means includes: a constant current circuit for supplying a constant current to the light-emitting elements, the constant current being determined by a reference value given; and a reference value selecting means for selecting one of a plurality of reference values and giving the value selected to the constant current circuit.

[0018] According to the display apparatus of the invention, when the light-emitting element to be a capacitive load is driven, the reference value selecting means is controlled such that, with regard to the period for which a current is fed to the light-emitting element, the value of the constant current supplied to the element for a specific period started at the point at which the current starts to be supplied is greater than the value of the constant current supplied to the element for the remaining period. A delay in rising of drive voltage is thereby suppressed.

[0019] According to the display apparatus of the invention, the reference values may be any of reference voltages, reference currents and reference resistance values.

[0020] The display apparatus of the invention may further comprise a control means for controlling the reference value selecting means such that, with regard to a period for which a current is fed to one of the light-emitting elements, a value of a constant current supplied to the element for a specific period started at a point at

which the current starts to be supplied is greater than a value of a constant current supplied to the element for a remaining period.

[0021] According to the display apparatus of the invention, the display may further include a plurality of scanning electrodes and a plurality of data electrodes intersecting the scanning electrodes, and each of the light-emitting elements is located at an intersection between each of the scanning electrodes and each of the data electrodes and connected to these scanning and data electrodes. In addition, the drive means may supply a constant current to the light-emitting elements through the data electrodes.

[0022] According to the display apparatus of the invention, the light-emitting elements may be organic electroluminescent elements.

[0023] A method of the invention is provided for driving a display apparatus including: a display including a plurality of light-emitting elements; and a drive means for driving the light-emitting elements by selectively supplying power required for light emission to the elements; the drive means including: a constant current circuit for supplying a constant current to the light-emitting elements, the constant current being determined by a reference value given; and a reference value selecting means for selecting one of a plurality of reference values and giving the value selected to the constant current circuit. The method comprises the step of supplying a current from the drive means to one of the light-emitting elements while the reference value selecting means is controlled such that, with regard to a period for which the current is fed to the light-emitting element, a value of a constant current supplied to the element for a specific period started at a point at which the current starts to be supplied is greater than a value of a constant current supplied to the element for a remaining period.

[0024] According to the method of driving the display apparatus of the invention, a current is supplied to the light-emitting element as described above, so that a delay in rising of drive voltage is suppressed.

[0025] According to the method of the invention, the reference values may be any of reference voltages, reference currents and reference resistance values.

[0026] According to the method of the invention, the display may further include a plurality of scanning electrodes and a plurality of data electrodes intersecting the scanning electrodes, and each of the light-emitting elements is located at an intersection between each of the scanning electrodes and each of the data electrodes and connected to these scanning and data electrodes. In addition, the drive means may supply a constant current to the light-emitting elements through the data electrodes.

[0027] According to the method of the invention, the light-emitting elements may be organic electroluminescent elements.

[0028] Other and further objects, features and advantages of the invention will appear more fully from the fol-

lowing description.

BRIEF DESCRIPTION OF THE DRAWINGS

[0029]

FIG. 1 is a block diagram illustrating an example of the entire configuration of a display apparatus of an embodiment of the invention.

FIG. 2 is a schematic circuit diagram illustrating the configuration of the organic EL display, the scanning electrode drive circuit and the data electrode drive section of FIG. 1.

FIG. 3 is a circuit diagram showing the main part of FIG. 2.

FIG. 4 is a circuit diagram that illustrates an example of configuration of the constant current circuit of FIG. 3 and its peripheral circuitry.

FIG. 5 is a circuit diagram that illustrates an example of a reference value generating circuit of the embodiment of the invention.

FIG. 6 is a circuit diagram that illustrates another example of the reference value generating circuit of the embodiment of the invention.

FIG. 7 is a circuit diagram that illustrates the main part of the constant current circuit when the reference value generating circuit of FIG. 6 is utilized.

FIG. 8 is a circuit diagram that illustrates still another example of the reference-value generating circuit of the embodiment.

FIG. 9 is a circuit diagram that illustrates still another example of the reference value generating circuit of the embodiment.

FIG. 10 is a circuit diagram that illustrates the main part of the constant current circuit when the reference value generating circuit of FIG. 8 or 9 is utilized.

FIG. 11 is a circuit diagram that illustrates still another example of the reference value generating circuit of the embodiment.

FIG. 12 is a circuit diagram that illustrates still another example of the reference value generating circuit of the embodiment.

FIG. 13 is an explanatory view for describing an example of configuration of the organic EL display of the embodiment.

FIG. 14 illustrates the waveform of current supplied to the organic EL element and the waveform of voltage across the organic EL element, according to the embodiment.

FIG. 15 illustrates the waveform of current supplied to the capacitive load from the constant current source, and the waveform of voltage across the capacitive load.

BEST MODE FOR CARRYING OUT THE INVENTION

[0030] An embodiment of the invention will now be de-

scribed in detail with reference to the accompanying drawings.

[0031] FIG. 1 is a block diagram illustrating an example of the entire configuration of a display apparatus of the embodiment of the invention. The display apparatus of the embodiment comprises an organic EL display 1 incorporating: scanning electrodes and data electrodes that are arranged in a matrix; and a plurality of organic EL elements that function as light-emitting elements connected to the respective scanning electrodes and data electrodes, each of the organic EL elements being located at the intersection of each of the scanning electrodes and each of the data electrodes. Each of the EL elements illuminates when a specific voltage is applied across the element by each of the scanning electrodes and each of the data electrodes. The organic EL display 1 corresponds to the display of the invention.

[0032] The display apparatus of the embodiment further comprises: a scanning electrode drive circuit 2 for driving the scanning electrodes of the display 1; a data electrode drive section 3 for driving the data electrodes of the display 1; a main controller 4 for outputting data to be displayed at the display 1 and data relating to display; a display controller 5 for controlling the timing of display at the display 1 and the display size and so on in response to the display data obtained from the main controller 4. The display apparatus further comprises: a display data storage 6 connected to the display controller 5 and provided for retaining the display data obtained from the main controller 4; an oscillator 7 for generating a clock to be used at the main controller 4 and supplying this clock thereto; and an oscillator 8 for generating a clock to be used at the display controller 5 and supplying this clock thereto. The scanning electrode drive circuit 2 and the data electrode drive section 3 correspond to the drive means of the invention that selectively supplies power required for light emission to the EL elements. The display controller 5 corresponds to the control means of the invention.

[0033] The scanning electrode drive circuit 2 is connected to the scanning electrodes of the display 1 through a connector 12. In this embodiment a plurality of data electrodes are divided into four groups. The data electrode drive section 3 includes four data electrode drive circuits 3A to 3D for driving the data electrodes of the respective groups. The drive circuits 3A to 3D are connected to the data electrodes of the respective groups through connectors 13A to 13D. The connectors 12 and 13A to 13D may be heat seal connectors or flexible substrates, for example.

[0034] The main controller 4 is connected to the display controller 5 through a control bus 21, a data bus 22 and an address bus 23. The display controller 5 is connected to the display data storage 6 through a control bus 24, a data bus 25 and an address bus 26.

[0035] The display controller 5 is connected to the drive circuits 2 and 3A to 3D through a signal line 27 for sending a latch pulse from the display controller 5 to the

drive circuits 2 and 3A to 3D. The latch pulse is a signal that indicates the timing of switching of the scanning electrodes to be selected and the timing of display of one line. The display controller 5 is connected to the drive circuits 2 and 3A to 3D through a control bus 28. The display controller 5 is connected to the drive circuits 3A to 3D through a data bus 29.

[0036] The main controller 4 sends the display controller 5 a control signal for instructing data input or output through the control bus 21 and for giving instruction for the operation of the display data storage 6. The main controller 4 also sends address data to the display controller 5 through the address bus 23, and sends display data and commands thereto through the data bus 22.

[0037] The display controller 5 sends the display data storage 6 a control signal through the control bus 24, and address data through the address bus 26. Through the data bus 25, the display controller 5 gives the display data storage 6 the display data sent from the main controller 4 and writes the data therein, or reads display data from the storage 6.

[0038] The display controller 5 sends a control signal to each of the drive circuits 2 and 3A to 3D through the control bus 28, and sends a latch pulse thereto through the signal line 27 to control each of the drive circuits 2 and 3A to 3D. In addition, the display controller 5 transfers display data to the drive circuits 3A to 3D through the data bus 29 to control the display. When data of an image (or a character) to be displayed is dot data created by organic EL elements, that is, dots (pixels) each of which is provided at each intersection of the matrix of the EL display 1, the display controller 5 generates such a signal that the scanning electrode and the data electrode corresponding to the coordinates of the dot to be displayed are driven. Furthermore, the display controller 5 also performs control of frame-by-frame driving and the drive ratio (duty) of the scanning electrodes and the data electrodes and so on.

[0039] The main controller 4 may be, in general, implemented by a multipurpose micro processor (MPU) and control algorithms and so on stored in storage media, such as read only memory (ROM) and a random access memory (RAM), connected to the MPU. The main controller 4 may be any type of processor such as a complex instruction set computer (CISC), a reduced instruction set computer (RISC) or a digital signal processor (DSP), regardless of the configuration of the processor. Furthermore, the main controller 4 may be made up of a combination of logic circuits such as an application specified integrated circuit. Although the main controller 4 of FIG. 1 is independent, the controller 4 may be created as a part of the display controller 5 or a controller and so on of the apparatus on which the display 1 is mounted.

[0040] The display controller 5 may be made up of components such as: a control circuit made of, for example, a composite logic circuit or a processor having a specific computing function; a buffer memory used

when the control circuit sends data to the external main controller 4 and so on and receives data therefrom; a timing signal generator circuit (an oscillator circuit) for providing the control circuit with a timing signal, a display timing signal, a timing signal for reading data from an external storage and so on or writing data therein; a storage control circuit for exchanging display data and so on with the external storage; a drive signal sending circuit for generating a drive signal based on the display data read from the external storage or sent from an external source, or the display data obtained by processing such display data, and sending out the drive signal; and several types of registers for storing data sent from an external source relating to the display function or the display and so on used for display, or storing control commands and so on.

[0041] The display data storage 6 retains, for example, data (a conversion table) required for developing image data sent from an external source at the organic EL display 1 as matrix data, and matrix data that represents specific character data or image data, and so on. Reading and writing of such data is performed by designating the storage location (address) of each data as necessary. The display data storage 6 having such a function is preferably a semiconductor memory such as a RAM (such as a video RAM [VRAM]) or a ROM, but may be any other storage medium such as a medium utilizing optics or magnetism.

[0042] The circuit configuration of FIG. 1 is no more than an example of configuration for driving the organic EL display 1, and may be any other configuration that has equivalent functions.

[0043] FIG. 2 is a schematic circuit diagram illustrating the configuration of the organic EL display 1, the scanning electrode drive circuit 2 and the data electrode drive section 3 of the display apparatus of the embodiment. In this embodiment the display 1 has the configuration of matrix electrodes and driven by the dynamic drive method. According to the embodiment, the scanning electrodes are driven as electron injection electrodes, and the data electrodes are driven as hole injection electrodes.

[0044] The organic EL display 1 includes: scanning electrodes RL1 to RL_n and data electrodes CL1 to CL_m that are arranged in a matrix; and a plurality of organic EL elements EL_{1,1} to EL_{m,n} that function as a plurality of light-emitting elements connected to the respective scanning electrodes and data electrodes, each of the organic EL elements being located at the intersection of each of the scanning electrodes and each of the data electrodes. Each of the EL elements is illuminated when the difference in electric potential between the scanning electrode and the data electrode connected to the EL element is equal to or greater than a specific threshold value. RL_y (y = 1 to n) indicates the scanning electrode of yth row. CL_x (x = 1 to m) indicates the data electrode of xth column. EL_{x,y} indicates the organic EL element of xth column and yth row. The organic EL elements are

capacitive loads. FIG. 2 illustrates the organic EL elements as parallel circuits of diode components and parasitic capacitances.

[0045] The scanning electrode drive circuit 2 is connected to the scanning electrodes RL1 to RLn of the display 1, and drives the electrodes RL1 to RLn such that the electrodes RL1 to RLn are selected by turns. The data electrode drive section 3 (the data electrode drive circuits 3A to 3D) is connected to the data electrodes CL 1 to CLm of the display 1, and drives the electrodes CL1 to CLm such that any of the electrodes CL1 to CLm is selected.

[0046] The scanning electrode drive circuit 2 includes switches S21 to S2n whose number is n. The moving contact of each of the switches S21 to S2n is connected to each of the scanning electrodes RL1 to RLn. A high voltage Vs is applied to one of the two fixed contacts of each of the switches S21 to S2n. A ground voltage (0 volt) is applied to the other one of the fixed contacts of each of the switches S21 to S2n. The drive circuit 2 has the moving contact of one of the switches connected to the ground-voltage-side fixed contact. A ground voltage is thereby applied to the scanning electrode connected to this switch, and the scanning electrode is selected. The drive circuit 2 has the moving contact of another one of the switches connected to the Vs-side fixed contact. A high voltage Vs is thereby applied to the scanning electrode connected to this switch, and the scanning electrode is nonselected. The drive circuit 2 repeats those operations for the switches S21 to S2n by turns and performs line-by-line sequential drive.

[0047] Reference is now made to FIG. 3 to describe the configuration of the data electrode drive section 3. FIG. 3 is a circuit diagram showing the main part of FIG. 2. In FIG. 3 one of the data electrodes CL1 to CLm is indicated with CL. In FIG. 3 organic EL elements D1, D2, D3 and so on connected to the data electrode CL and the respective scanning electrodes RL 1, RL2, RL3 and so on are indicated with diode components. The data electrode CL is connected to the anodes of the diode components of the EL elements D1, D2, D3 and so on. The scanning electrodes RL 1, RL2, RL3 and so on are connected to the cathodes of the diode components of the EL elements D1, D2, D3 and so on.

[0048] As shown in FIG. 3, the data electrode drive section 3 includes constant current circuits 31 each of which is provided for supplying a constant current to the data electrode CL. The drive section 3 further includes: a switch S11 provided between the constant current circuit 31 and a voltage source 30 for supplying a high voltage Vd to the constant current circuit 31; and a switch S12 having an end connected to the data electrode CL. The switch S12 has the other end grounded through a low-impedance line. The switch S11 is opened and closed in response to a pixel signal (display data) corresponding to the data electrode CL. The switch S12 is opened and closed such that the state thereof is the reverse of the state of the switch S11.

[0049] The data electrode drive section 3 operates the switches S11 and S12 in synchronization with the operations of the switches S21 to S2n of the scanning electrode drive circuit 2. To be specific, when one of the scanning electrodes is selected, the drive section 3 closes the switch S11 corresponding to the data electrode CL connected to the organic RL element to be illuminated, and opens the switch S12, and thereby supplies the constant current generated at the constant current circuit 31 to the EL element. The drive section 3 opens the switch S11 and closes the switch S12 so that the ground voltage is applied to the data electrodes CL connected to EL elements other than the element to be illuminated.

[0050] As shown in FIG. 3, the scanning electrodes RL1, RL2, RL3 and so on are grounded or connected to the feeder lines of high voltage Vs through the respective switches S21, S22, S23 and so on that are switched by turns by a shift register and so on of the scanning electrode drive circuit 2. In the example shown in FIG. 3, the switches S21, S22, S23 and so on are connected to the cathodes of the diode components of the EL elements D1, D2, D3 and so on that function as loads. Therefore, the scanning electrodes RL1, RL2, RL3 and so on may be maintained at high impedance, instead of connecting them to the feeder lines of high voltage Vs.

[0051] In the example shown in FIG. 3, the scanning electrode RL2 is grounded through the switch S22 and selected. The pixel signal corresponding to the data electrode CL is '1' and the switch S11 is closed while the switch S12 is opened. Therefore, the constant current circuit 31 receives the high voltage Vd and brought to an operating state, and the data electrode CL is separated from the ground point by the switch S12. As a result, a current of constant value is fed to the ground point from the constant current circuit 31 through the data electrode CL, the EL element D2, the scanning electrode RL2 and the switch S22. The EL element D2 thereby illuminates. Since the high voltage Vs is applied to the scanning electrodes RL1 and RL3 through the switches S21 and S23, respectively, no current is fed to the EL elements D1 and D3, and the EL elements D1 and D3 do not illuminate.

[0052] If the scanning electrode selected shifts from the electrode RL2 to the electrode RL3, the switch S22 is switched and the high voltage Vs is applied to the electrode RL2. The current fed to the EL element D2 is stopped and the EL element D2 stops illuminating. If the pixel signal corresponding to the data electrode CL is '0' when the scanning electrode RL3 is selected, the switch S11 is opened and the switch S12 is closed. As a result, the operation of the constant current circuit 31 is stopped and the data electrode CL is grounded through the switch S12. Discharging is thereby started through the switch S12 from the data electrode CL and the inside of the EL element D2 that have conducted to the constant current circuit 31 until immediately before this moment.

[0053] If the pixel signal corresponding to the data

electrode CL is maintained at '0' for a long period, discharging from the data electrode CL and the inside of the EL element D2 is entirely completed. Then, during a period until the pixel signal turns to '1', the EL element D2 is kept reverse-biased, and a reduction in light-emitting characteristic accompanying migration of particles in the EL element D2 is recovered. Such recovery is performed on not only the EL element D2 but also all the EL elements connected to the data electrode CL and the scanning electrodes that are not selected.

[0054] FIG. 4 is a circuit diagram that illustrates an example of configuration of the constant current circuit 31 of FIG. 3 and its peripheral circuitry. In this example each of the switches S11 and S12 is made up of a field effect transistor. The field effect transistor making up the switch S11 has a gate to which a pixel signal Sc intact is applied. The field effect transistor making up the switch S12 has a gate to which a signal made of the pixel signal Sc reversed by an inverter 36 is applied.

[0055] The constant current circuit 31 of FIG. 4 includes: a resistor 32 having ends one of which is connected to the switch S11; a field effect transistor 33 having a drain connected to the other end of the resistor 32, and a source connected to the data electrode CL; and an operational amplifier 34 having an output connected to the gate of the transistor 33. The amplifier 34 has inputs one of which is connected to the node between the resistor 32 and the transistor 33 and to the other of which reference voltage Vref as the reference value is applied.

[0056] In the constant current circuit 31 of FIG. 4 the amplifier 34 generates a control voltage corresponding to the relationship in magnitude between the reference voltage Vref and the voltage at the node between the resistor 32 and the transistor 33. This control voltage is applied to the gate of the transistor 33 so that the value of the current fed to the transistor 33, that is, the current supplied to the data current CL, is kept constant.

[0057] FIG. 3 and FIG. 4 illustrate the example of configuration including the switch S11 that is opened and closed in response to the pixel signal Sc and provided between the constant current circuit 31 and the feeder line of constant voltage. However, such a switch may be included in the constant current circuit as part of it, or the constant current source itself in the constant current circuit may be operated as a switch. Such a configuration allows the constant current circuit connected to the data electrode CL to be switched between the operating state and the non-operating state, in response to whether the pixel signal Sc supplied to the data electrode CL is '1' or '0'. An example of configuration that has the constant current source itself operate as a switch is that the constant current source is formed as a current mirror, and the primary constant current circuit that determines the current capability of the constant current source is stopped to operate, so that the operation of the constant current source is stopped.

[0058] FIG. 5 is a circuit diagram that illustrates an example of a reference value generating circuit that gen-

erates the reference voltage Vref as the reference value given to the constant current circuit 31 of FIG. 4. The reference value generating circuit 40 of FIG. 5 includes Zener diodes TD1 and TD2, a switch S3 and a resistor 41. Each of the Zener diodes TD1 and TD2 has an anode grounded. The switch S3 has a moving contact and two fixed contacts. The Zener diode TD1 has a cathode connected to one of the fixed contacts of the switch S3. The Zener diode TD2 has a cathode connected to the other one of the fixed contacts of the switch S3. The resistor 41 has an end to which supply voltage V is applied, and another end connected to the moving contact of the switch S3. The node between the resistor 41 and the switch S3 is connected to an output 42 from which the reference voltage Vref is outputted. The resistor 41 is provided for controlling the current fed to the output 42.

[0059] The reference value generating circuit 40 of FIG. 5 is provided in the data electrode drive section 3 of FIG. 1, and gives common reference voltage Vref to the constant current circuit 31 provided in each of the data electrodes. The switch S3 is controlled by the display controller 5 in synchronization with a latch pulse. The control signal switching the switch S3 may be outputted from the display controller 5 or may be generated at the circuit in the data electrode drive section 3, based on the latch pulse outputted from the display controller 5.

[0060] According to the reference value generating circuit 40 of FIG. 5, the Zener voltage value of the Zener diode TD1 is greater than that of the Zener diode TD2. As a result, the reference voltage Vref obtained when the moving contact of the switch S3 is connected to the fixed contact on a side of the Zener diode TD1 is greater than the reference voltage Vref obtained when the moving contact of the switch S3 is connected to the fixed contact on a side of the Zener diode TD2. According to the constant current circuit 31 of FIG. 4, the greater the reference voltage Vref, the greater the constant current outputted. Therefore, it is possible to change the value of the constant current outputted from the constant current circuit 31 by switching the switch S3 in the reference value generating circuit 40 to change the magnitude of the reference voltage Vref.

[0061] According to the constant current circuit 31 of FIG. 4, the magnitudes of the reference voltages Vref with respect to each other and magnitudes of the constant current values with respect to each other stated above may be reversed. In this case, the reference value generating circuit 40 outputs the smaller reference voltage Vref when the greater constant current is selected. The circuit 40 outputs the greater reference voltage Vref when the smaller constant current is selected.

[0062] The reference value generating circuit 40 corresponds to the reference value selecting means of the invention. The constant current circuit 31 and the reference value generating circuit 40 make up the constant current apparatus of this embodiment of the invention.

[0063] The reference value given to the constant current circuit 31 is not limited to the reference voltage Vref

but may be a reference current. FIG. 6 is a circuit diagram that illustrates an example of a reference value generating circuit that generates such a reference current. The reference value generating circuit 50 of FIG. 6 includes Zener diodes TD3 and TD4, a switch S4 and resistors 51, 52 and 53. The resistor 51 has ends one of which receives supply voltage V and the other of which is connected to the cathode of the Zener diode TD3. The anode of the Zener diode TD3 is grounded. The resistor 52 has ends one of which receives supply voltage V and the other of which is connected to the cathode of the Zener diode TD4. The anode of the Zener diode TD4 is grounded. The switch S4 has a moving contact and two fixed contacts. The node between the resistor 51 and the Zener diode TD3 is connected to one of the fixed contacts of the switch S4. The node between the resistor 52 and the Zener diode TD4 is connected to the other one of the fixed contacts of the switch S4. The resistor 53 has an end connected to the moving contact of the switch S4, and another end connected to an output 54 from which the reference voltage Iref is outputted.

[0064] Here, the Zener voltage value of the Zener diode TD3 is Vz1, the Zener voltage value of the Zener diode TD4 is Vz2, and the resistance value of the resistor 53 is R. In this case, the reference current Iref is Vz1/R when the moving contact of the switch S4 is connected to the fixed contact on a side of the Zener diode TD3. The reference current Iref is Vz2/R when the moving contact of the switch S4 is connected to the fixed contact on a side of the Zener diode TD4. Therefore, the reference value generating circuit 50 of FIG. 6 is allowed to selectively output two types of reference currents Iref having different values if the Zener voltage values Vz1 and Vz2 of the Zener diodes TD3 and TD4 are different.

[0065] To supply the reference current Iref outputted from the reference value generating circuit 50 of FIG. 6 to the constant current circuit 31 of FIG. 4 as a reference value, the input of the operational amplifier 34 that receives the reference value may be grounded through a resistor 56 having a specific resistance value, and the reference current Iref may be supplied to the node between the input of the amplifier 34 and the resistor 56, as shown in FIG. 7.

[0066] The reference value given to the constant current circuit 31 may be a reference resistance value. FIG. 8 is a circuit diagram that illustrates an example of a reference value generating circuit that generates such a reference resistance value. The reference value generating circuit 60 of FIG. 8 includes a switch S5 and resistors R1 and R2 having different resistance values. The switch S5 has a moving contact and two fixed contacts. One of the fixed contacts of the switch S5 is grounded through the resistor R1 and the other fixed contact is grounded through the resistor R2. The moving contact is connected to an output 61. The reference resistance value Rref outputted from the reference value generating circuit 60 is the resistance value of the resis-

tor R1 or R2 selectively connected to the output 61 through the switch S5.

[0067] FIG. 9 is a circuit diagram that illustrates another example of the reference value generating circuit that generates a reference resistance value. The reference value generating circuit 60 of FIG. 9 includes an open/close switch S6 and resistors R3 and R4 having different resistance values. The switch S6 has a moving contact and a fixed contact. The resistor R3 has an end grounded and another end connected to the output 61. The resistor R4 has an end grounded and another end connected to the fixed contact of the switch S6. The moving contact of the switch S6 is connected to the output 61. According to the reference value generating circuit 60 of FIG. 9, the reference resistance value Rref outputted from the output 61 is the resistance value of the resistor R3 when the switch S6 is opened, and the combined resistance value of the resistors R3 and R4 when the switch S6 is closed.

[0068] To supply the reference resistance value Rref outputted from the reference value generating circuit 60 of FIG. 8 or FIG. 9, to the constant current circuit 31 of FIG. 4 as a reference value, the supply voltage V may be applied through a resistor 66 having a specific resistance value to the input of the operational amplifier 34 that receives the reference value, and the output of the reference value generating circuit 60 from which the reference resistance value Rref is outputted may be connected to the node between the input of the amplifier 34 and the resistor 66, as shown in FIG. 10.

[0069] The method of switching the reference value through the use of the open/close switch as shown in FIG. 9 may be applied to the reference value generating circuit 40 that generates a reference voltage as shown in FIG. 5. In this case, for example, the circuit 40 may include an open/close switch S7 as shown in FIG. 11, in place of the switch S3 of FIG. 5. The switch S7 has an end connected to the cathode of the Zener diode TD2, and another end connected to the output 42. The cathode of the Zener diode TD1 is connected to the output 42. A resistor 71 of FIG. 11 is provided, in place of the resistor 41 of FIG. 5, for controlling the current fed to the output 42. According to the reference value generating circuit 40 of FIG. 11, the Zener voltage value of the Zener diode TD1 is greater than that of the Zener diode TD2, and the reference voltage Vref outputted from the output 42 when the switch S7 is opened is a first reference voltage. It is thereby possible to generate a second reference voltage lower than the first reference voltage when the switch S7 is closed.

[0070] Similarly, the method of switching the reference value through the use of the switch as shown in FIG. 9 may be applied to the reference value generating circuit 50 that generates a reference current as shown in FIG. 6. In this case, for example, the circuit 50 may include a Zener diode TD, an open/close switch S8 and resistors 80, 81 and 82, as shown in FIG. 12. The resistor 80 has an end to which the supply voltage V is ap-

plied, and another end connected to the cathode of the Zener diode TD. The anode of the Zener diode TD is grounded. The resistor 81 has an end connected to the node between the resistor 80 and the Zener diode TD, and another end connected to an output 84 from which the reference voltage I_{ref} is outputted. The switch S8 has an end connected to the node between the resistor 80 and the Zener diode TD, and another end grounded through the resistor 82. According to the reference value generating circuit 50 of FIG. 12, the reference current I_{ref} outputted from the output 84 when the switch S8 is opened is a first reference current. When the switch S8 is closed, part of the current fed to the resistor 81 when the switch S8 is opened is shunted to the resistor 82. It is thereby possible to generate a second reference current lower than the first reference current.

[0071] According to the method of driving the display apparatus of the embodiment of the invention, the reference value (reference voltage V_{ref} , reference current I_{ref} or reference resistance value R_{ref}) outputted from the reference value generating circuit (40, 50 or 60) is switched such that, with regard to the period for which a current is supplied to the organic EL element, that is, the period for which one of the scanning electrodes is selected, the value of the constant current (hereinafter called a first constant current value) supplied to the EL element for a specific period started at the point at which the current starts to be supplied is greater than the value of the constant current (hereinafter called a second constant current value) supplied to the EL element for the remaining period. The second constant current value is L_0 that allows the voltage across the organic EL element to be a constant value V_0 when the steady state is achieved.

[0072] The timing at which switching between the first and second constant current values is made depends on the number of scanning electrodes of the display 1. Basically, the period for which the first constant current value is selected is equal to or shorter than one fifth, or preferably one tenth, or more preferably one twentieth of the period for which one of the scanning electrodes is selected. However, a constant current enough for illumination is supplied to the EL element, regardless of whether the first or second constant current value is selected. A desired luminance intensity is thereby achieved.

[0073] Reference is now made to FIG. 13 to describe an example of configuration of the organic EL display used in the display apparatus of the embodiment. FIG. 13 illustrates the example of configuration of the organic EL display. The EL display 1 of this example has a structure that a hole injection layer 93, a hole migration layer 94, a light-emitting layer 95 and an electron injection and migration layer 96 are stacked in this order between hole injection electrodes (data electrodes) 92 and electron injection electrodes (scanning electrodes) 97 arranged in a matrix on a substrate 91, the hole injection layer 93 being closest to the hole injection electrodes 92. A pro-

tection layer is further provided, if necessary, on the stacked layers on which a sealing plate of glass, for example, is further placed. Each of the organic EL elements is formed at the intersection of each of the hole injection electrodes 92 and each of the electron injection electrodes 97. In this example the substrate 91 is a glass substrate and the data electrodes 92 are transparent electrodes.

[0074] An example of method of fabricating the organic EL display of FIG. 13 will now be described. In this example a thin film made of ITO and having a thickness of about 100 nm is formed through sputtering on the glass substrate 91. The thin film of ITO thus obtained is patterned by etching through the use of photolithography to form the hole injection electrodes 92 having a pattern of 256 by 64 dots (pixels), for example.

[0075] Next, ultraviolet-ozone cleaning is performed on the surface of the substrate on which the above-mentioned hole injection electrodes 92 and wiring for the electrodes and so on are formed. A mask for vapor deposition is then placed on the substrate surface, and the substrate is fastened to a substrate holder of a vacuum deposition apparatus. The pressure in the apparatus is then reduced.

[0076] Next, in the vacuum deposition apparatus, polythiophene is deposited to a thickness of 10 nm on the hole injection electrodes 92 to form the hole injection layer 93. Next, while the reduced pressure in the apparatus is maintained, N, N'-diphenyl-N, N'-m-tolyl-4, 4'-diamino-1, 1'-biphenyl (TPD) is deposited to a thickness of 35 nm on the hole injection layer 93 to form the hole migration layer 94.

[0077] Next, while the reduced pressure in the apparatus is maintained, tris (8-quinolinolate) aluminum (Alq_3) is deposited to a thickness of 50 nm on the hole migration layer 94 to form the light-emitting layer 95 and the electron injection and migration layer 96.

[0078] Next, while the reduced pressure in the apparatus is maintained, the structure made up of the above-mentioned layers formed on the substrate 91 is moved from the vacuum deposition apparatus to a sputtering apparatus in which a film of AlLi (Li concentration: 7.2 at%) having a thickness of 50 nm is formed on the electron injection and migration layer 96 through sputtering with 1.0 Pa of pressure. The electron injection electrodes 97 are thus formed. In this case, the sputtering gas is Ar, power is 100 W, the target size is 4 inches in diameter, and the distance between the substrate and the target is 90 mm.

[0079] Next, while the reduced pressure is maintained, the structure including the layers up to the electron injection electrodes 97 is moved to the sputtering apparatus in which an Al protection electrode having a thickness of 200 nm is formed on the electron injection electrodes 97 through direct current sputtering using an Al target. The above-mentioned mask for deposition is removed when formation of all the layers is completed. Finally, the glass sealing plate is bonded to the structure

including the layers up to the Al protection electrode. Fabrication of the organic EL display 1 is thus completed.

[0080] The display apparatus may be fabricated as follows, using the organic EL display 1 fabricated as described above. One scanning electrode drive circuit 2 made up of a 64-output driver IC and four data electrode drive circuits 3A to 3D each of which is made up of a 64-output driver IC are tape-carrier-packaged (TAB), for example, on the display 1. Furthermore, the drive circuits 2 and 3A to 3D are connected through flat cables to a printed circuit board (PCB) on which control circuitry such as controllers, a micro computer and so on are mounted. The display apparatus is thus completed.

[0081] The operation of the display apparatus of this embodiment will now be described. According to the display apparatus, the scanning electrode drive circuit 2 drives the scanning electrodes of the display 1 such that these electrodes are selected one by one. The drive circuit 2 applies a ground voltage to one of the scanning electrodes that is selected, and applies the high voltage V_s to the scanning electrodes that are not selected. The data electrode drive circuits 3A to 3D drives the data electrodes of the display 1, based on the display data, such that any of the data electrodes is selected. The drive circuits 3A to 3D supply a constant current from the constant current circuit 31 to one of the data electrodes that is selected, and apply a ground voltage to the data electrodes that are not selected. A constant current is supplied from the constant current circuit 31 to the organic EL element connected to the scanning electrode and the data electrode that are selected. This EL element thereby illuminates.

[0082] According to this embodiment, the reference value such as reference voltage V_{ref} , reference current I_{ref} or reference resistance value R_{ref} given to the constant current circuit 31 is switched. As a result, with regard to the period for which one of the scanning electrodes is selected, the value of the first constant current supplied to the EL element for a specific period started at the point at which the current starts to be supplied is greater than the value of the second constant current supplied to the EL element for the remaining period.

[0083] FIG. 14 illustrates the waveform of current supplied to the organic EL element and the waveform of voltage across the organic EL element, according to the embodiment. FIG. 14 (a) illustrates the waveform of current supplied to the EL element. FIG. 14 (b) illustrates the waveform of voltage across the EL element when the current having the waveform of (a) is supplied. In this embodiment the second constant current value is L_0 that allows the drive voltage across the EL element to be a constant value V_0 when the steady state is achieved. The first constant current value is L_1 greater than the second constant current value L_0 . The second constant current value L_0 falls within the range of 50 μ A to 1 mA, or preferably the range of 50 μ A to 800 μ A, for example. In this case, the first constant current value L_1

falls within the range of 100 μ A to 2 mA, or preferably the range of 200 μ A to 1.5 mA, for example, where $L_1 > L_0$.

[0084] According to the embodiment, the value of constant current supplied to the organic EL element is switched as described above, so that a delay in rising of drive voltage of the EL element is suppressed for a period in which a charging current is fed to the EL element. According to the embodiment, the wave of the drive voltage of the EL element when rising may abruptly rise and reach the constant value V_0 , as shown with a solid line of FIG. 14 (b), or may once become greater than the constant value V_0 and then become equal to the constant value V_0 , as indicated with two broken lines. Alternatively, the wave may have a blunt portion that is not as blunt as the wave of the prior-art example shown in FIG. 15 (b).

[0085] According to the embodiment described so far, when the organic EL element to be a capacitive load is driven, the reference value given to the constant current circuit 31 is switched. As a result, with regard to the period for which a current is fed to the EL element, the value of the constant current supplied to the EL element for a specific period started at the point at which the current starts to be supplied is greater than the value of the constant current supplied to the EL element for the remaining period. A delay in rising of drive voltage of the EL element is thereby suppressed for a period in which a charging current is fed to the EL element, and a delay in illumination of the EL element is suppressed. According to the embodiment, it is possible to hasten the rising of drive voltage of the EL element, so that the drive rate of the EL display 1 is increased.

[0086] According to the embodiment, the value of constant current is changed by selecting the reference value given to the constant current circuit 31. As a result, it is not necessary to provide the respective data electrodes with a plurality of constant current circuits that generate a plurality of types of constant currents having different values. An increase in circuit size is thereby prevented.

[0087] According to the embodiment, the EL display 1 is driven at a constant current. It is therefore easy to determine the circuit constant of the reference value generating circuit for determining the reference value corresponding to the constant current value.

[0088] The present invention is not limited to the foregoing embodiment but may be practiced in still other ways. For example, the configuration of the constant current circuit 31 is not limited to the one shown in FIG. 4 but may be any other one that is capable of changing the constant current value by switching the reference value such as reference voltage V_{ref} , reference current I_{ref} or reference resistance value R_{ref} . The reference value generating circuit is not limited to the ones having the configurations shown in FIG. 5, FIG. 6, FIG. 8, FIG. 9, FIG. 11 and FIG. 12, but may be any other one having a configuration that is capable of outputting a plurality

of reference values selectively. For example, the reference value generating circuit may be the one that generates a plurality of reference voltages V_{ref} , reference currents I_{ref} or reference resistance values R_{ref} through the use of a potentiometer. The number of types of the reference values is not limited to two but may be three or greater. In such a case, it is preferred to switch the reference values such that the closer to the point at which the current is started to be supplied, the greater the value of constant current supplied to the organic EL element.

[0089] The invention is not limited to a display apparatus incorporating a display made up of electrodes arranged in a matrix, but may be applied to a display apparatus incorporating a display made up of electrodes arranged in segments.

[0090] The invention is not limited to an organic EL display apparatus but may be applied to display apparatuses in general that incorporate light-emitting elements to be capacitive loads.

[0091] According to the constant current apparatus of the invention described so far, when the capacitive load is driven, the reference value selecting means is controlled such that, with regard to the period for which a current is fed to the capacitive load, the value of the constant current supplied to the capacitive load for a specific period started at the point at which the current starts to be supplied is greater than the value of the constant current supplied to the capacitive load for the remaining period. A delay in rising of drive voltage is thereby suppressed. According to the constant current apparatus of the invention, the value of constant current is changed by selecting the reference value given to the constant current circuit. As a result, it is not necessary to provide a plurality of constant current circuits that generate a plurality of types of constant currents having different values. An increase in circuit size is thereby prevented.

[0092] According to the display apparatus or the method of driving the same of the invention, when the light-emitting element to be a capacitive load is driven, the reference value selecting means is controlled such that, with regard to the period for which a current is fed to the light-emitting element, the value of the constant current supplied to the element for a specific period started at the point at which the current starts to be supplied is greater than the value of the constant current supplied to the element for the remaining period. A delay in rising of drive voltage is thereby suppressed. According to the display apparatus or the method of driving the same of the invention, the value of constant current is changed by selecting the reference value given to the constant current circuit. As a result, it is not necessary to provide a plurality of constant current circuits that generate a plurality of types of constant currents having different values. An increase in circuit size is thereby prevented.

[0093] Obviously many modifications and variations of the present invention are possible in the light of the

above teachings. It is therefore to be understood that within the scope of the appended claims the invention may be practiced otherwise than as specifically described.

Claims

1. A constant current apparatus comprising:
 - a constant current circuit for outputting a constant current determined by a reference value given; and
 - a reference value selecting means for selecting one of a plurality of reference values and giving the value selected to the constant current circuit.
2. The constant current apparatus according to claim 1 wherein the reference values are any of reference voltages, reference currents and reference resistance values.
3. The constant current apparatus according to claim 1, being used for driving a capacitive load.
4. A display apparatus comprising:
 - a display including a plurality of light-emitting elements; and
 - a drive means for driving the light-emitting elements by selectively supplying power required for light emission to the elements; wherein the drive means includes:
 - a constant current circuit for supplying a constant current to the light-emitting elements, the constant current being determined by a reference value given; and
 - a reference value selecting means for selecting one of a plurality of reference values and giving the value selected to the constant current circuit.
5. The display apparatus according to claim 4 wherein the reference values are any of reference voltages, reference currents and reference resistance values.
6. The display apparatus according to claim 4, further comprising a control means for controlling the reference value selecting means such that, with regard to a period for which a current is fed to one of the light-emitting elements, a value of a constant current supplied to the element for a specific period started at a point at which the current starts to be supplied is greater than a value of a constant current supplied to the element for a remaining period.

7. The display apparatus according to claim 4 wherein:

the display further includes a plurality of scanning electrodes and a plurality of data electrodes intersecting the scanning electrodes, and each of the light-emitting elements is located at an intersection between each of the scanning electrodes and each of the data electrodes and connected to these scanning and data electrodes; and
the drive means supplies a constant current to the light-emitting elements through the data electrodes.

5

10

15

8. The display apparatus according to claim 4 wherein the light-emitting elements are organic electroluminescent elements.

9. A method of driving a display apparatus including:
a display including a plurality of light-emitting elements; and a drive means for driving the light-emitting elements by selectively supplying power required for light emission to the elements; the drive means including: a constant current circuit for supplying a constant current to the light-emitting elements, the constant current being determined by a reference value given; and a reference value selecting means for selecting one of a plurality of reference values and giving the value selected to the constant current circuit; the method comprising the step of

20

25

30

supplying a current from the drive means to one of the light-emitting elements while the reference value selecting means is controlled such that, with regard to a period for which the current is fed to the light-emitting element, a value of a constant current supplied to the element for a specific period started at a point at which the current starts to be supplied is greater than a value- of a constant current supplied to the element for a remaining period.

35

40

10. The method according to claim 9 wherein the reference values are any of reference voltages, reference currents and reference resistance values.

45

11. The method according to claim 9 wherein:

50

the display further includes a plurality of scanning electrodes and a plurality of data electrodes intersecting the scanning electrodes, and each of the light-emitting elements is located at an intersection between each of the scanning electrodes and each of the data electrodes and connected to these scanning and data electrodes; and

55

the drive means supplies a constant current to the light-emitting elements through the data electrodes.

12. The method according to claim 9 wherein the light-emitting elements are organic electroluminescent elements.

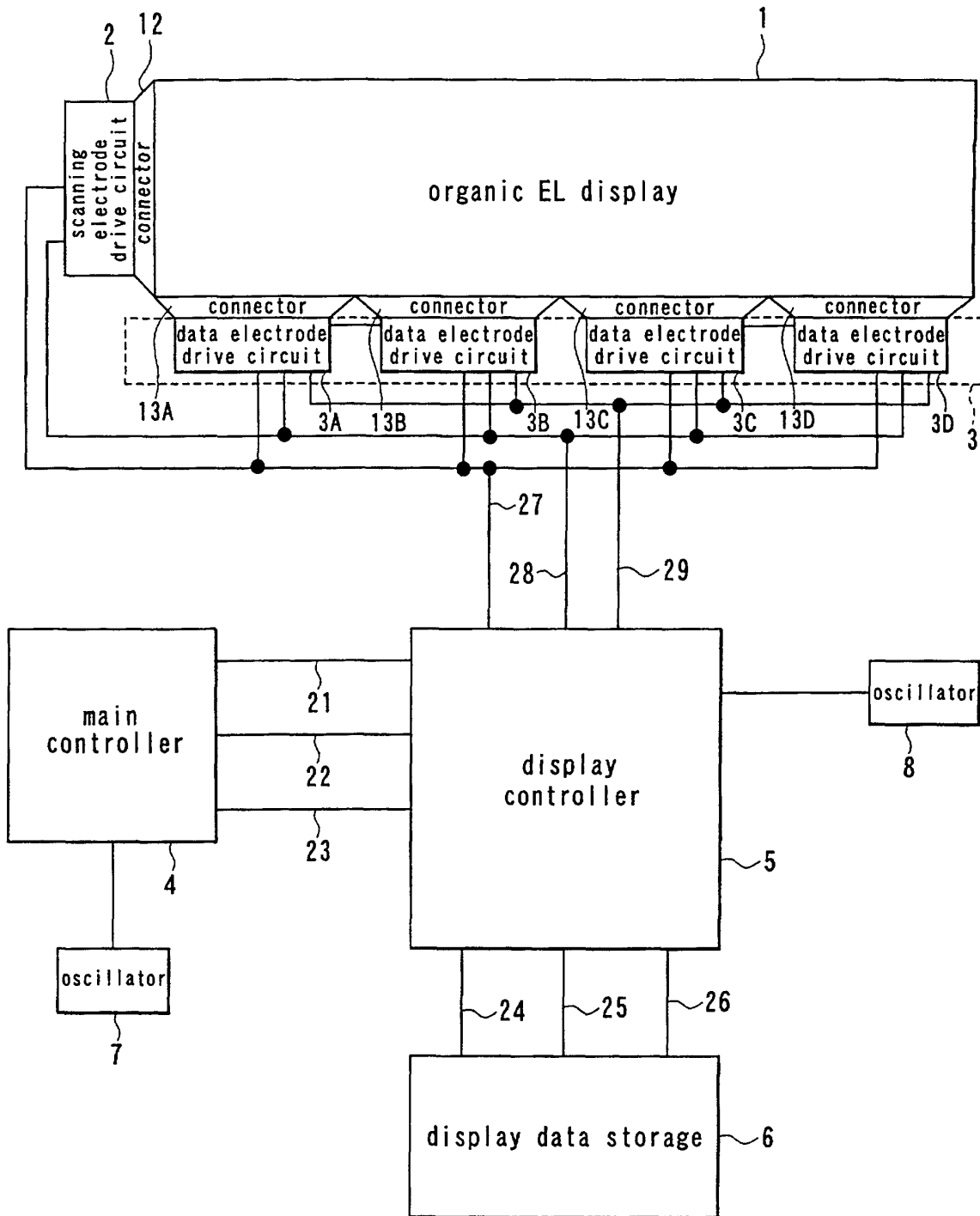

FIG. 1

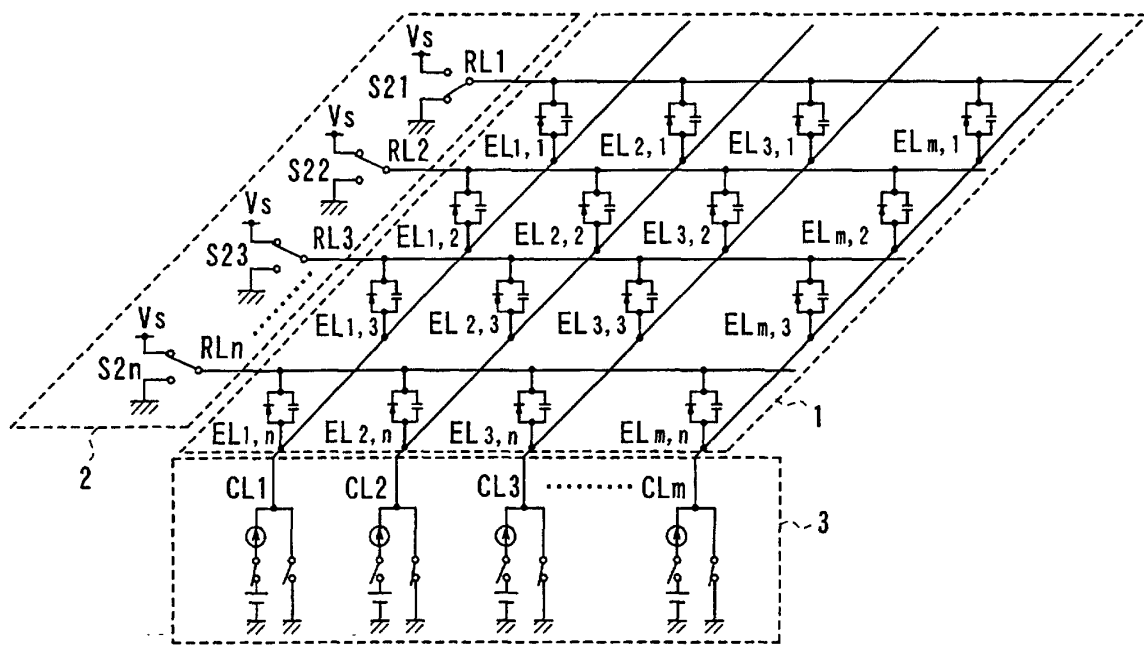

FIG. 2

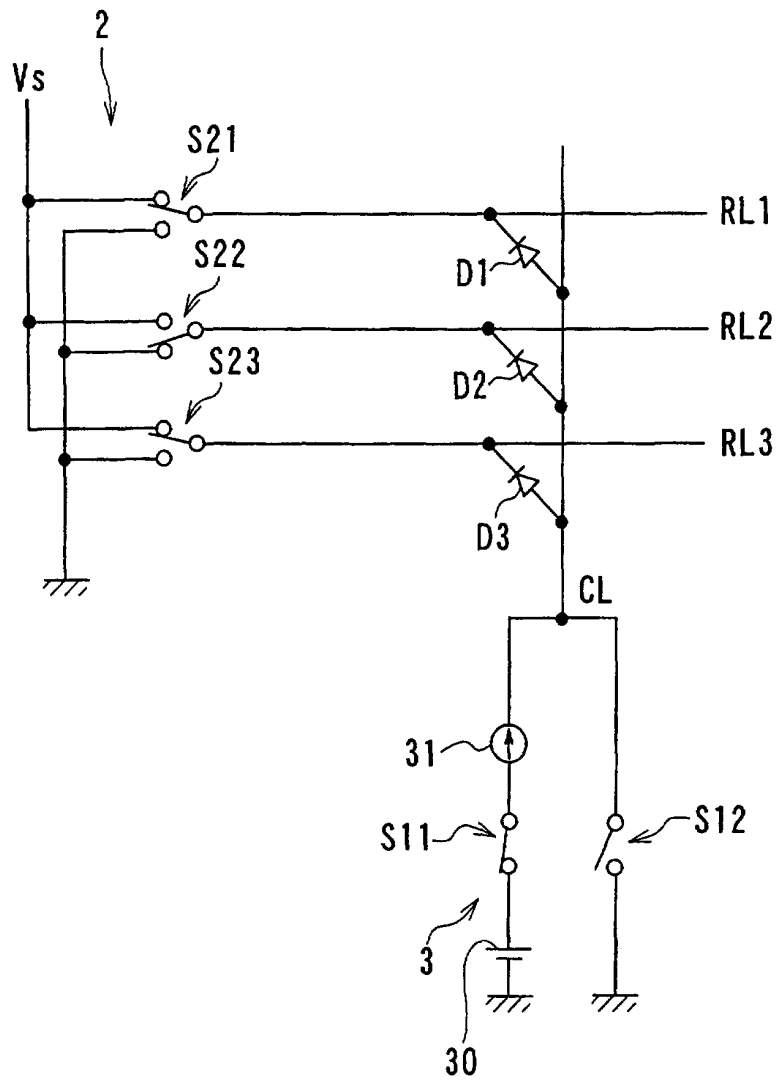

FIG. 3

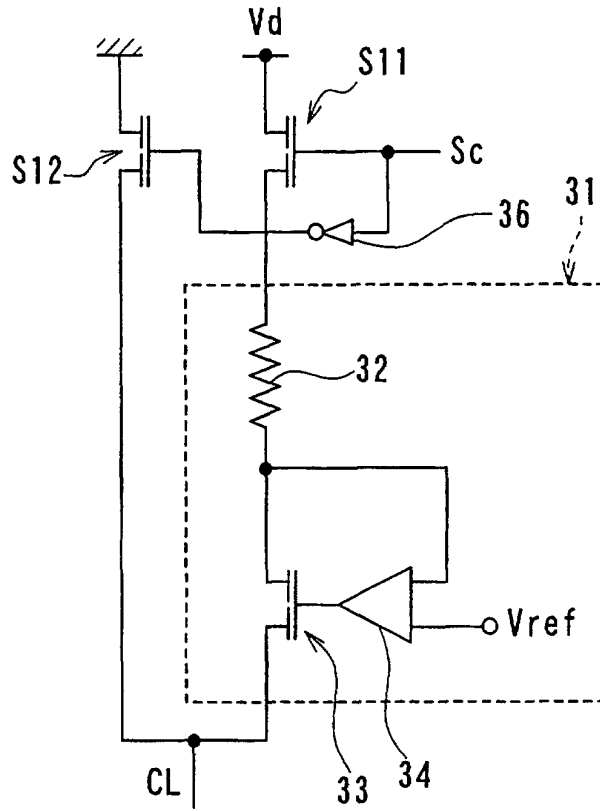

FIG. 4

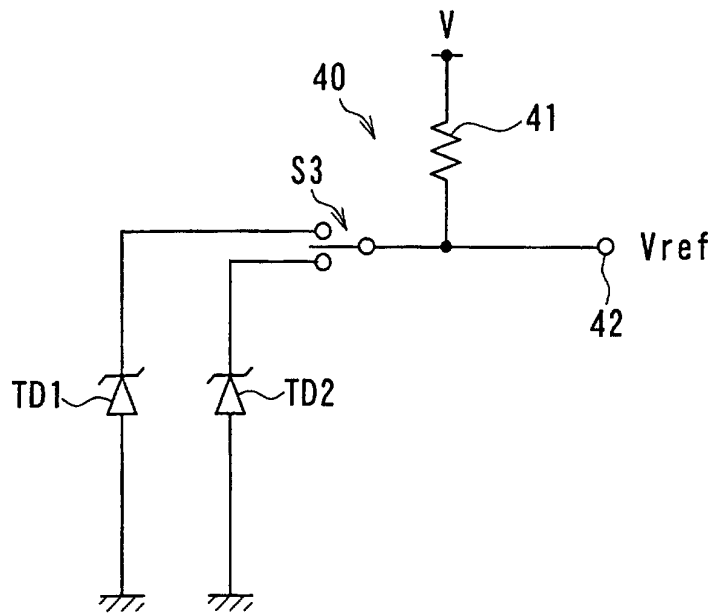

FIG. 5

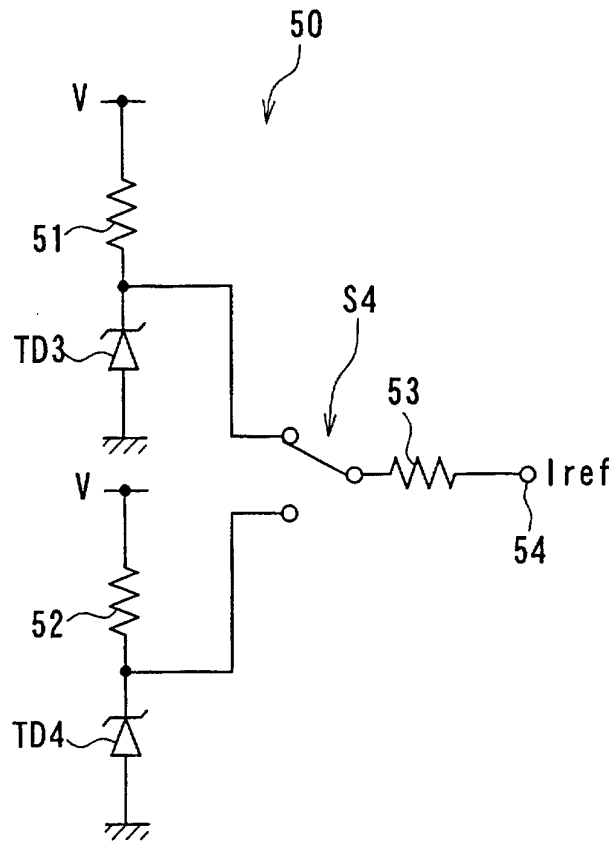

FIG. 6

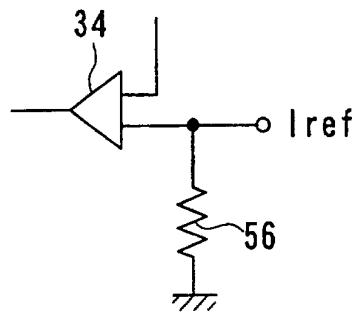

FIG. 7

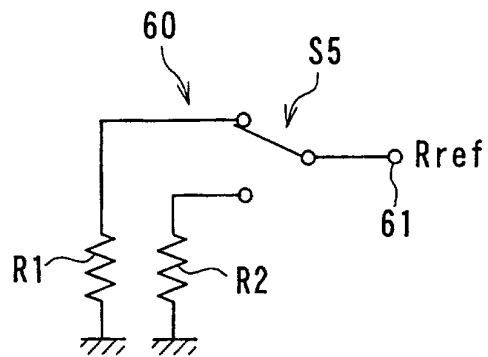

FIG. 8

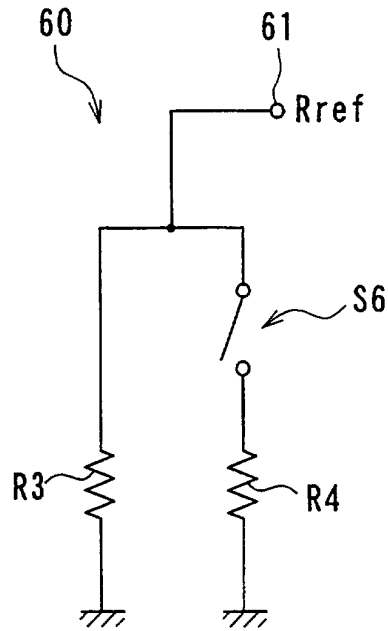

FIG. 9

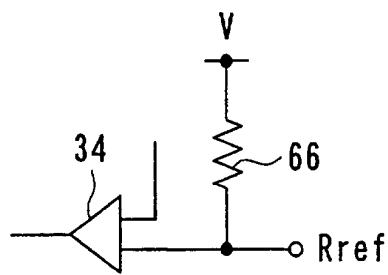

FIG. 10

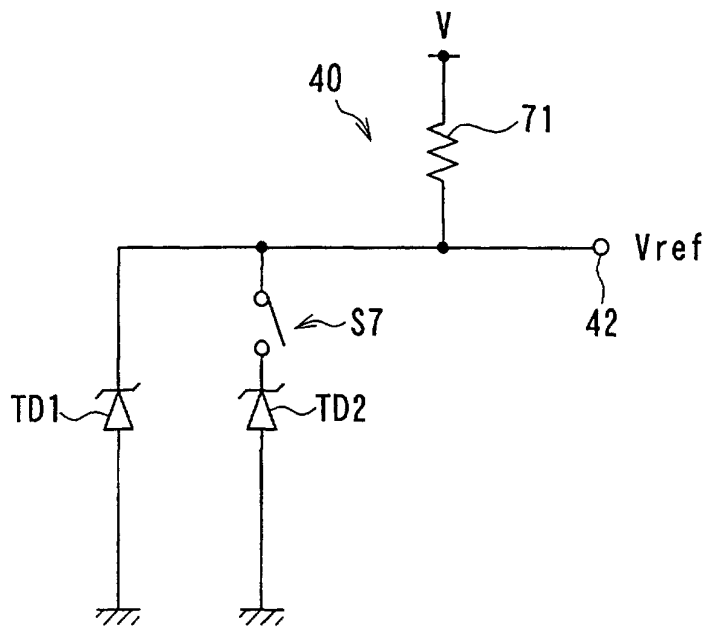

FIG. 11

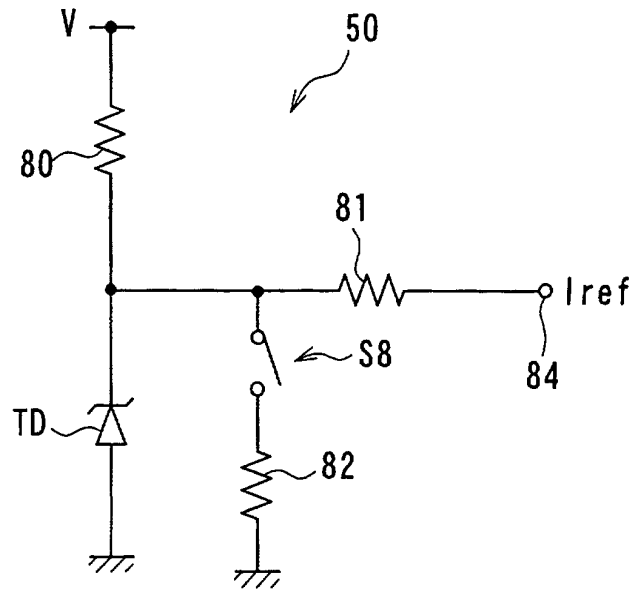

FIG. 12

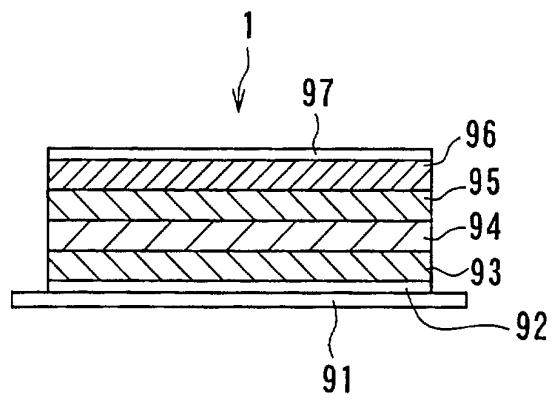

FIG. 13

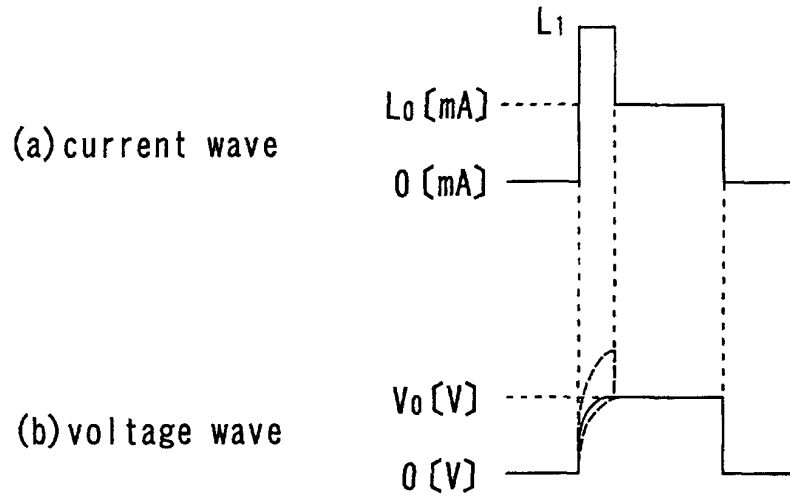

FIG. 14

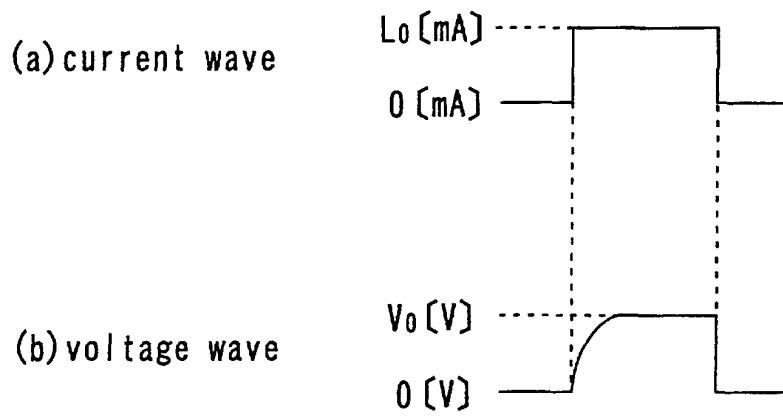

FIG. 15

INTERNATIONAL SEARCH REPORT

International application No.

PCT/JP00/05978

A. CLASSIFICATION OF SUBJECT MATTER Int.Cl. ⁷ G09G3/30, H03F3/34, G06F3/08		
According to International Patent Classification (IPC) or to both national classification and IPC		
B. FIELDS SEARCHED Minimum documentation searched (classification system followed by classification symbols) Int.Cl. ⁷ G09G3/00-3/38		
Documentation searched other than minimum documentation to the extent that such documents are included in the fields searched Jitsuyo Shinan Koho 1922-1996 Toroku Jitsuyo Shinan Koho 1994-2000 Kokai Jitsuyo Shinan Koho 1971-2000 Jitsuyo Shinan Toroku Koho 1996-2000		
Electronic data base consulted during the international search (name of data base and, where practicable, search terms used) WPI		
C. DOCUMENTS CONSIDERED TO BE RELEVANT		
Category*	Citation of document, with indication, where appropriate, of the relevant passages	Relevant to claim No.
X	JP, 11-45071, A (NEC Corporation), 16 February, 1999 (16.02.99), Par. Nos. 0016, 0024 to 0029; Figs. 3 to 4 (Family: none)	1-12
X	JP, 11-231834, A (Pioneer Electronic Corporation), 27 August, 1999 (27.08.99), Claims 5, 8; Par. Nos. 0003, 0032 to 0036; Figs. 4 to 6 (Family: none)	1-12
P, X	JP, 2000-138572, A (NEC Corporation), 16 May, 2000 (16.05.00), Par. Nos. 0017 to 0026; Fig. 2 (Family: none)	1-6, 8 9-10, 12
<input type="checkbox"/> Further documents are listed in the continuation of Box C.		<input type="checkbox"/> See patent family annex.
* Special categories of cited documents: "A" document defining the general state of the art which is not considered to be of particular relevance "E" earlier document but published on or after the international filing date "L" document which may throw doubts on priority claim(s) or which is cited to establish the publication date of another citation or other special reason (as specified) "O" document referring to an oral disclosure, use, exhibition or other means "P" document published prior to the international filing date but later than the priority date claimed	"T" later document published after the international filing date or priority date and not in conflict with the application but cited to understand the principle or theory underlying the invention "X" document of particular relevance; the claimed invention cannot be considered novel or cannot be considered to involve an inventive step when the document is taken alone "Y" document of particular relevance; the claimed invention cannot be considered to involve an inventive step when the document is combined with one or more other such documents, such combination being obvious to a person skilled in the art "&" document member of the same patent family	
Date of the actual completion of the international search 28 November, 2000 (28.11.00)	Date of mailing of the international search report 12 December, 2000 (12.12.00)	
Name and mailing address of the ISA/ Japanese Patent Office	Authorized officer	
Facsimile No.	Telephone No.	

Form PCT/ISA/210 (second sheet) (July 1992)

专利名称(译)	恒流装置，显示装置及其驱动方法		
公开(公告)号	EP1164565A1	公开(公告)日	2001-12-19
申请号	EP2000956893	申请日	2000-09-04
[标]申请(专利权)人(译)	东京电气化学工业株式会社		
申请(专利权)人(译)	TDK株式会社		
当前申请(专利权)人(译)	TDK株式会社		
[标]发明人	FURUKAWA HIROTADA SAITOH YOSHIHIRO		
发明人	FURUKAWA, HIROTADA SAITOH, YOSHIHIRO		
IPC分类号	H05B33/08 G09F9/30 G09G3/20 G09G3/30 G09G3/32 H01L27/32 H01L51/50 H03F3/34 G06F3/08		
CPC分类号	G09G3/3216 G09G3/3283 G09G2310/0251 G09G2310/06 G09G2330/028		
优先权	1999297593 1999-10-20 JP 2000192023 2000-06-27 JP		
外部链接	Espacenet		

摘要(译)

本发明的目的是在驱动作为电容性负载的发光元件的同时抑制驱动电压的上升延迟，同时防止电路尺寸的增加。一种显示装置，包括：有机EL显示器（1），包括有机EL元件作为发光元件；扫描电极驱动电路（2），用于驱动显示器（1）的扫描电极；数据电极驱动部分（3）用于驱动显示器（1）的数据电极。数据电极驱动部分（3）包括用于各个数据电极的恒流电路，每个恒流电路向每个数据电极提供恒定电流。每个恒流电路允许输出的恒定电流的值响应于给定的参考值（例如参考电压）而改变。切换参考值，使得关于选择一个扫描电极的周期，在特定时间段内提供给有机EL元件之一的恒定电流的值从电流开始的点开始。待提供的电流大于在剩余时间内提供给EL元件的恒定电流的值。

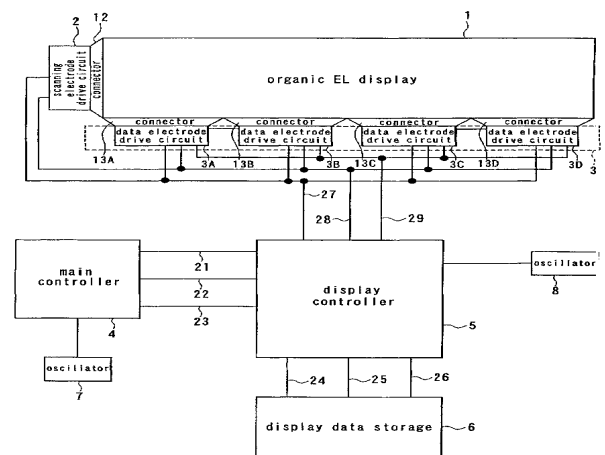

FIG. 1