

(19) World Intellectual Property Organization
International Bureau



(43) International Publication Date
10 March 2005 (10.03.2005)

PCT

(10) International Publication Number
WO 2005/022500 A1

- (51) International Patent Classification⁷: G09G 3/32, 3/00
- (21) International Application Number:
PCT/IB2004/002729
- (22) International Filing Date: 20 August 2004 (20.08.2004)
- (25) Filing Language: English
- (26) Publication Language: English
- (30) Priority Data:
0320212.4 29 August 2003 (29.08.2003) GB

(81) Designated States (unless otherwise indicated, for every kind of national protection available): AE, AG, AL, AM, AT, AU, AZ, BA, BB, BG, BR, BW, BY, BZ, CA, CH, CN, CO, CR, CU, CZ, DE, DK, DM, DZ, EC, EE, EG, ES, FI, GB, GD, GE, GH, GM, HR, HU, ID, IL, IN, IS, JP, KE, KG, KP, KR, KZ, LC, LK, LR, LS, LT, LU, LV, MA, MD, MG, MK, MN, MW, MX, MZ, NA, NI, NO, NZ, OM, PG, PH, PL, PT, RO, RU, SC, SD, SE, SG, SK, SL, SY, TJ, TM, TN, TR, TT, TZ, UA, UG, US, UZ, VC, VN, YU, ZA, ZM, ZW.

- (71) Applicant (for all designated States except US): KONINKLIJKE PHILIPS ELECTRONICS N.V. [NL/NL]; Groenewoudseweg 1, NL-5621 BA Eindhoven (NL).
- (72) Inventor; and
- (75) Inventor/Applicant (for US only): FISH, David, A. [GB/GB]; c/o Philips Intellectual Property & Standards, Cross Oak Lane, Redhill, Surrey RH1 5HA (GB).
- (74) Agent: WILLIAMSON, Paul, L.; c/o Philips Intellectual Property & Standards, Cross Oak Lane, Redhill, Surrey RH1 5HA (GB).

(84) Designated States (unless otherwise indicated, for every kind of regional protection available): ARIPO (BW, GH, GM, KE, LS, MW, MZ, NA, SD, SL, SZ, TZ, UG, ZM, ZW), Eurasian (AM, AZ, BY, KG, KZ, MD, RU, TJ, TM), European (AT, BE, BG, CH, CY, CZ, DE, DK, EE, ES, FI, FR, GB, GR, HU, IE, IT, LU, MC, NL, PL, PT, RO, SE, SI, SK, TR), OAPI (BF, BJ, CF, CG, CI, CM, GA, GN, GQ, GW, ML, MR, NE, SN, TD, TG).

Declaration under Rule 4.17:

— as to applicant's entitlement to apply for and be granted a patent (Rule 4.17(ii)) for the following designations AE, AG, AL, AM, AT, AU, AZ, BA, BB, BG, BR, BW, BY, BZ,

[Continued on next page]

(54) Title: DATA SIGNAL DRIVER FOR LIGHT EMITTING DISPLAY

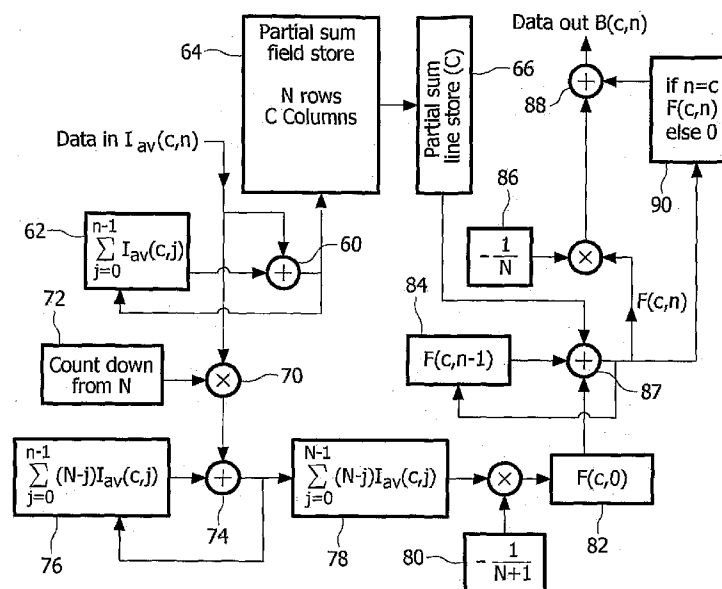

(57) Abstract: A display has light emitting elements (2) arranged in rows and columns, with pixels in a column being supplied with current from a respective column power supply line (26). Target pixel drive currents are determined corresponding to desired pixel brightness levels based on a model of the pixel current-brightness characteristics. These are modified to take account of the voltage on the column power supply line (26) at each pixel resulting from the currents drawn from the column power supply line, and the dependency of the pixel brightness characteristics on the voltage on the column power supply line at the pixel. The invention addresses the problem of vertical cross-talk that occurs in active matrix LED displays due to the finite output impedance of the current providing TFTs as well as the finite resistance of metals used to form power supply lines.

WO 2005/022500 A1



CA, CH, CN, CO, CR, CU, CZ, DE, DK, DM, DZ, EC, EE, EG, ES, FI, GB, GD, GE, GH, GM, HR, HU, ID, IL, IN, IS, JP, KE, KG, KP, KR, KZ, LC, LK, LR, LS, LT, LU, LV, MA, MD, MG, MK, MN, MW, MX, MZ, NA, NI, NO, NZ, OM, PG, PH, PL, PT, RO, RU, SC, SD, SE, SG, SK, SL, SY, TJ, TM, TN, TR, TT, TZ, UA, UG, UZ, VC, VN, YU, ZA, ZM, ZW, ARIPO patent (BW, GH, GM, KE, LS, MW, MZ, NA, SD, SL, SZ, TZ, UG, ZM, ZW), Eurasian patent (AM, AZ, BY, KG, KZ, MD, RU, TJ, TM), European patent (AT, BE, BG, CH, CY, CZ, DE, DK, EE, ES, FI, FR, GB, GR, HU, IE,

IT, LU, MC, NL, PL, PT, RO, SE, SI, SK, TR), OAPI patent (BF, BJ, CF, CG, CI, CM, GA, GN, GQ, GW, ML, MR, NE, SN, TD, TG)

Published:

— with international search report

For two-letter codes and other abbreviations, refer to the "Guidance Notes on Codes and Abbreviations" appearing at the beginning of each regular issue of the PCT Gazette.

DATA SIGNAL DRIVER FOR LIGHT EMITTING DISPLAY

5

This invention relates to light emitting display devices, for example electroluminescent displays, particularly active matrix display devices having thin film switching transistors associated with each pixel.

10 Matrix display devices employing electroluminescent, light-emitting, display elements are well known. The display elements may comprise organic thin film electroluminescent elements, for example using polymer materials, or else light emitting diodes (LEDs) using traditional III-V semiconductor compounds. Recent developments in organic electroluminescent materials,
15 particularly polymer materials, have demonstrated their ability to be used practically for video display devices. These materials typically comprise one or more layers of a semiconducting conjugated polymer sandwiched between a pair of electrodes, one of which is transparent and the other of which is of a material suitable for injecting holes or electrons into the polymer layer.

20 The polymer material can be fabricated using a CVD process, or simply by a spin coating technique using a solution of a soluble conjugated polymer. Ink-jet printing may also be used. Organic electroluminescent materials exhibit diode-like I-V properties, so that they are capable of providing both a display function and a switching function, and can therefore be used in passive type
25 displays. Alternatively, these materials may be used for active matrix display devices, with each pixel comprising a display element and a switching device for controlling the current through the display element.

Display devices of this type have current-driven display elements, so that a conventional, analogue drive scheme involves supplying a controllable current
30 to the display element. It is known to provide a current source transistor as part of the pixel configuration, with the gate voltage supplied to the current source

transistor determining the current through the display element. A storage capacitor holds the gate voltage after the addressing phase.

Figure 1 shows a known pixel circuit for an active matrix addressed electroluminescent display device. The display device comprises a panel having a row and column matrix array of regularly-spaced pixels, denoted by the blocks 1 and comprising electroluminescent display elements 2 together with associated switching means, located at the intersections between crossing sets of row (selection) and column (data) address conductors 4 and 6. Only a few pixels are shown in the Figure for simplicity. In practice, there may be several hundred rows and columns of pixels. The pixels 1 are addressed via the sets of row and column address conductors by a peripheral drive circuit comprising a row, scanning, driver circuit 8 and a column, data, driver circuit 9 connected to the ends of the respective sets of conductors.

The electroluminescent display element 2 comprises an organic light emitting diode, represented here as a diode element (LED) and comprising a pair of electrodes between which one or more active layers of organic electroluminescent material is sandwiched. The display elements of the array are carried together with the associated active matrix circuitry on one side of an insulating support. Either the cathodes or the anodes of the display elements are formed of transparent conductive material. The support is of transparent material such as glass and the electrodes of the display elements 2 closest to the substrate may consist of a transparent conductive material such as ITO so that light generated by the electroluminescent layer is transmitted through these electrodes and the support so as to be visible to a viewer at the other side of the support.

Figure 2 shows in simplified schematic form a known pixel and drive circuitry arrangement for providing voltage-programmed operation. Each pixel 1 comprises the EL display element 2 and associated driver circuitry. The driver circuitry has an address transistor 16 which is turned on by a row address pulse on the row conductor 4. When the address transistor 16 is turned on, a voltage on the column conductor 6 can pass to the remainder of the pixel. In particular, the address transistor 16 supplies the column conductor voltage to a current

source 20, which comprises a drive transistor 22 and a storage capacitor 24. The column voltage is provided to the gate of the drive transistor 22, and the gate is held at this voltage by the storage capacitor 24 even after the row address pulse has ended. The drive transistor 22 draws a current from the power supply line 26.

The drive transistor 22 in this circuit is implemented as a p-type TFT, so that the storage capacitor 24 holds the gate-source voltage fixed. This results in a fixed source-drain current through the transistor, which therefore provides the desired current source operation of the pixel.

The invention is concerned particularly with pixel configurations in which the power supply lines 26 are parallel to the column conductors 6, for example formed from the same metal layer. This metal layer is typically the top metal of the fabrication process, which can be thicker and therefore less resistive than the bottom metal layer usually used for forming the row conductors. The length of the power line is also then shorter for landscape displays.

If the pixel circuit of Figure 2 is modified to use vertical power lines, it will suffer severe cross-talk. In particular, the pixel operates by shutting off current supply to the display element while the data is stored in the pixel, and the data voltage stored is a voltage which is relative to the power supply line voltage. The data voltage will be corrupted by power supply line voltage drops caused by other pixels in the power column which are still drawing current along the resistive power line.

Current mirror circuits do not suffer this drawback, as the power supply to the pixel can be continuous and does not need to be interrupted. For this reason, current mirror circuits are typically used for implementing pixel configurations with vertical power supply lines.

There are two basic types of current mirror circuit. A switched current mirror circuit samples a current from the data conductor and can be arranged to draw the same current from the data conductor during pixel programming as during display. However, the complexity of such pixel circuits makes them unsuitable for large displays.

A matched current mirror circuit draws current for a sampling transistor and the drive transistor during a pixel programming phase so that the pixel programming phase alters the voltages on the power supply line. Although the pixels sample the current (so that the pixel output is not directly related to the voltage on the power supply line), a second order cross talk effect remains, as will become apparent from the discussion below.

Figure 3 shows a matched current mirror circuit. In this circuit, the column conductor 6 is coupled to a controllable current source 30. During pixel addressing, an address transistor 32 is turned on and the current drawn by the current source 30 is sourced by a current sampling transistor 34. A further transistor 36 is controlled by the same control line 38 as the address transistor 32, and provides that the gate of the sampling transistor and the gate of the drive transistor 22 are at the same voltage during addressing. As the source of these transistors are both connected to the power supply line 26, the source voltages and the gate-source voltages are the same. Thus, the current in the drive transistor mirrors the current in the sampling transistor.

If the sampling and drive transistors 34,22 have the same dimensions, the same current will be drawn, and the power supply line 26 will source double the current of the current source 30 during the addressing phase. In a more general case, the dimensions of the sampling transistor 34 and the drive transistor 22 may be different, so that the current mirror performs an amplification. In this case, the current drawn from the power supply line 26 will be taken to be $(1+W) \cdot I_D$ where I_D is the drive transistor current. W is a scaling factor for example based on the ratio between the channel widths of the two transistors. For identical matched transistors, $W=1$, and the current drawn is $2I_D$. At all other times, the current drawn from the power supply line is I_D .

The problem remains in the pixel circuit of Figure 3 that the thin film transistors are inherently non-ideal current source devices, as the output current will in fact depend on both the source and drain voltages rather than only on the gate-source voltage.

One problem with LED displays arises from the significant currents drawn by the pixels. The displays are typically backward-emitting, through the

substrate carrying the active matrix circuitry. This is the preferred arrangement because the desired cathode material of the EL display element is opaque, so that the emission is from the anode side of the EL diode, and furthermore it is not desirable to place this preferred cathode material against the active matrix circuitry. Metal row or column conductors are formed to define the power supply lines 26, and for these backward emitting displays they need to occupy the space between display areas, as they are opaque. For example, in a 12.5cm (diagonal) display, which is suitable for portable products, the power supply line conductor may be approximately 11cm long and 20 μ m wide. For a typical metal sheet resistance of 0.2 Ω /square, this gives a line resistance for a metal row conductor of 1.1k Ω .

A bright pixel may draw around 8 μ A, and the current drawn is distributed along the power supply line. The significant conductor resistance gives rise to voltage drops along the power supply line. This is a problem both for voltage-addressed pixels and current-addressed pixels.

Voltage drops along the power supply line mean that the drain-source voltage of the current-providing TFT will be reduced. The finite output impedance of the current-providing TFT then results in a reduction in its current. This change in current will again depend upon the current being drawn from all of the other pixels in the column, the TFT output impedance for the particular operating conditions, and the OLED I - V characteristic. In particular, the consequent changes in the anode voltage of the OLED display element will alter the brightness output of the display element for a given current sampled by the circuit. Therefore, a second order vertical cross-talk will occur because of the finite output impedance of the OLED driving TFT 22. This second order cross talk can still give visible cross-talk in large displays.

According to the invention, there is provided a method of determining the pixel drive signals to be applied to the pixels of an array of light emitting display elements arranged in rows and columns, with a plurality of the pixels in a column being supplied with current from a respective column power supply line

and the pixels being addressed row by row, the addressing of all rows defining a field period, the method comprising:

determining target pixel drive currents corresponding to desired pixel brightness levels based on a model of the pixel current-brightness characteristics;

modifying the target pixel drive currents to take account of:

the voltage on the column power supply line at each pixel resulting from the currents drawn from the column power supply line by the plurality of pixels in the column for each row addressing cycle in a field period; and

the dependency of the pixel brightness characteristics on the voltage on the column power supply line at the pixel.

By taking into account the dependency of the pixel brightness characteristics on the voltage on the power supply line at the pixel, the invention addresses the problem of vertical cross-talk that occurs in active matrix LED displays due to the finite output impedance of the current providing TFTs as well as the finite resistance of metals used to form power supply lines. The invention provides a signal processing scheme for correction of the cross-talk. The model used to form the target drive currents can assume a constant voltage on the power supply line, and is thus a constant model for all pixels and independent of the pixel drive signals applied to other pixels.

The compensation for the dependency of the pixel brightness characteristics on the voltage on the power supply line essentially takes into account the change in the operating point of the pixel components (for example the drain voltage of the drive transistor in the pixel configuration of Figure 3).

The technique of the invention is applicable to amorphous silicon and polysilicon technologies for any array that uses column power lines which supply current to columns of current-drawing pixels. It should be noted that the terms "row" and "column" used herein are somewhat arbitrary, and these terms are merely intended to denote an array of device elements arranged in an orthogonal matrix. A "column" power supply line is orthogonal to the "rows" of pixels which are addressed in sequence.

Each pixel is preferably programmed in a first phase and driven in a second phase, and wherein the step of modifying the target pixel drive currents further takes account of any differences in the current drawn by the pixels between the first and second phases.

5 In particular, some pixel drive schemes involve supplying more or less current in the programming phase than during driving of the pixel. By taking this into account, correct compensation can be provided for any pixel drive scheme.

The step of modifying the target pixel drive currents may comprise:

applying an algorithm to the target pixel drive currents which represents:

10 the relationship between the currents applied to the pixels in a column during a field period and the voltages on the column power supply line at the locations of the pixels; and

the dependency of the pixel brightness characteristics on the voltage on the column power supply line.

15 For example, applying an algorithm may comprise multiplying a vector of the target pixel drive currents for a column of pixels by the inversion of the matrix **M**, in which:

$$\mathbf{M} = \begin{bmatrix} -2 & 1 & & & & \\ 1 & -2 & 1 & & & \\ & \ddots & \ddots & \ddots & & \\ & & & 1 & -2 & 1 \\ & & & & 1 & -2 \end{bmatrix},$$

20 and wherein the number of rows and columns of matrix **M** is equal to the number of pixels in the column.

Each pixel may comprise a current sampling transistor which samples an input current and provides a drive voltage to a drive transistor, and the algorithm then uses a value including terms derived from:

25 the voltage-current characteristics of the drive transistor; and
the voltage-current characteristics of the light emitting display element.

In particular, the algorithm may also use a value including a term derived from the resistance of the column power supply line.

The algorithm may use a value $R\lambda/(1+\lambda/\mu)$, where R is the resistance of the column power supply line between adjacent pixels;

λ is the slope of the drain-source current vs. drain-source voltage curve of the drive transistor; and

μ is the slope of the current vs. voltage curve of the display element.

In order to reduce the computational overhead, the result of multiplying a vector of the target pixel drive currents for a column of pixels by the inversion of the matrix \mathbf{M} can be obtained by a recursive operation:

$$F(c,n) = F(c,n-1) + \sum_{j=0}^{n-1} I_{av}(c,j) + F(c,0)$$

in which:

$F(c,n)$ is the n th term of the vector result of multiplying the vector of the target pixel drive currents for the c th column of pixels by the inversion of the matrix \mathbf{M} , $F(c,0)$ being the first term; and

$I_{av}(c,j)$ is the target current for the j th pixel in the c th column, the first pixel being $j=0$.

In this recursive model:

$$F(c,0) = \frac{-1}{N+1} \sum_{j=0}^{N-1} (N-j) I_{av}(c,j),$$

in which:

N is the total number pixels in the column.

The values representing the dependency of the pixel brightness characteristics on the voltage on the column power supply line can be stored in a look up table, and the values of the look up table can be updated over time to enable changes in pixel brightness characteristics over time to be modeled. For example, the look up table values can be updated based on analysis of the characteristics of pixel compensation modules of the display.

The method of the invention can be used for driving an active matrix array of current-addressed light emitting display elements arranged in rows and columns, in which each row of pixels is addressed in a sequence and power is supplied to each column of pixels using a column power supply line.

5 The invention also provides a display device comprising an array of light emitting display elements arranged in rows and columns, with a plurality of the pixels in a column being supplied with current from a respective column power supply line and the pixels being addressed row by row, the addressing of all rows defining a field period, the device further comprising:

10 compensation circuitry for modifying target pixel drive currents to take account of the voltage on column power supply line at each pixel resulting from the currents drawn from the column power supply line by the plurality of pixels in the column for each row addressing cycle in a field period and the dependency of the pixel brightness characteristics on the voltage on the row
15 conductor at the pixel.

The compensation circuitry preferably comprises:

means for applying an algorithm to the target pixel drive currents which represents the relationship between the currents drawn by the pixels in a column and the voltages on the column power supply line at the locations of the
20 pixels and the dependency of the pixel brightness characteristics on the voltage on the row conductor.

Examples of the invention will now be described in detail with reference to the accompanying drawings, in which:

25 Figure 1 shows a conventional active matrix LED display;

Figure 2 shows a first conventional pixel layout for the display of Figure 1;

Figure 3 shows a second conventional pixel layout for the display of Figure 1 for use when vertical power lines are to be used;

30 Figure 4 is used to investigate the pixel output characteristics in response to changes in the power supply line voltage;

Figure 5 shows a part of Figure 4 in greater detail;

Figure 6 is an equivalent circuit used to derive the relationship between pixel currents and voltages on the power supply line;

Figure 7 shows circuitry for implementing part of a first example of method of the invention;

5 Figure 8 shows circuitry for implementing another part of the first example of method of the invention; and

Figure 9 shows circuitry for implementing part of a second example of method of the invention;

10 Figure 10 shows circuitry for implementing another part of the second example of method of the invention; and

Figure 11 shows dummy pixel circuits for use in a display of the invention.

The invention provides a scheme for determining the pixel drive signals
15 to be applied to the pixels of an array of light emitting display elements, using column power supply lines. A set of standard pixel drive currents, corresponding to desired pixel brightness levels, are modified to take account of the voltage variations on the column power line and particularly the effect these voltage variations have on the pixel brightness characteristics. The invention
20 also takes into account the different currents drawn by a pixel when being addressed and when driving the display element, in particular for a current-addressed pixel which performs a sampling operation of an input current. The modification of the pixel drive currents is to correct for vertical cross-talk.

The invention is applicable to various pixel layouts, but most importantly
25 to current-addressed pixels, as these are most frequently used in vertical power line arrangements.

A current-addressed pixel which performs a current sampling operation can be assumed to provide the desired output current immediately after addressing. However, subsequent changes in voltage on the power supply line
30 will influence the current output of the pixel. These changes in voltage will result when other pixels in the column are addressed.

In order to derive an algorithm for the correction of this vertical cross-talk, the following steps are taken:

a general expression for voltage drops on the column power line is obtained, for any combination of currents drawn by the pixels in a column;

5 the effect of these voltage drops on the pixel output brightness is then determined, this effect being the result of the output impedance of the in-pixel current source TFT; and

a correction scheme for the data is derived to compensate for the vertical cross talk.

10 To derive the correction algorithm, it is first necessary to calculate the average OLED current (not including addressing current) over a field time. This field time is the period of time between addressing phases for the row. The light output is proportional to this average current. It is given by:

$$15 \quad I_{av}(r) = \frac{1}{N} \left[I(r) + \sum_{j=r+1}^{r+N-1} (\Delta I(r, j) + I(r)) \right] \quad (1)$$

which can instead be written as:

$$I_{av}(r) = I(r) + \frac{1}{N} \left[\sum_{j=r+1}^{r+N-1} (\Delta I(r, j)) \right] \quad (1a)$$

20 where $I(r)$ is the OLED current when row r is addressed and $\Delta I(r, j)$ is the change in the OLED current on row r when row j is addressed (j can be viewed as a time sequence index). N is the number of rows and $I_{av}(r)$ is the average current supplied to the OLED on row r . The calculation is performed for one
 25 column only to reduce notational complexity, but every current in fact has a column index c as well as a row index r .

This equation assumes that the rows are addressed in order. Thus, when addressing row r , the rows 1 to $(r-1)$ have already been addressed in that field period, whereas the rows $(r+1)$ to N still draw currents from the previous
 30 addressing cycle. As the addressing is a cyclic operation, the first change in

current will be seen when the next row ($r+1$) is addressed, which is the lower summation limit. The last change in current to be seen will be the preceding row ($r-1$) being addressed in the next field period. This is the addressing phase ($r-1+N$), which is the upper summation limit.

5 In order to find an expression for the pixel current changes due to the power line voltage drops and the output impedance of the in-pixel current-providing TFT, a simple diagrammatic approach can be used.

Figure 4 shows the TFT and LED characteristics. The TFT characteristic curve plots the drain source current (I_{ds}) against the drain voltage (V_d) for a constant gate-source voltage. When the drain voltage reaches the column power line voltage, the drain-source voltage reaches zero. Thus, increasing voltage in the graph of Figure 5 corresponds to decreasing drain-source voltage, and the drain-source voltage is zero at the point where the curve crosses the x-axis. This point on the x-axis corresponds to the power line voltage.

15 The shift in the TFT characteristics is the result of the change in the power line voltage, assuming the gate-source voltage remains constant (as shown in Figure 3, the gate-source voltage is stored on a capacitor).

The LED characteristic curve is a load line plot of the LED and shows the anode voltage of the LED display element for a given current.

Where the TFT characteristic curve crosses the LED characteristic curve, the drain/anode voltage is defined and the current flowing. As the TFT has a non-infinite output impedance when in saturation, movements in the power supply voltage shift the TFT characteristic to give different output currents, even for a constant gate-source voltage. Thus, the power line voltage change is not fully compensated in a current-addressed pixel.

The region of current change shown in Figure 5 can be examined more closely in order to determine the change in anode/drain voltage and the change in current. This is shown in Figure 6.

30 An examination of the geometry in Figure 6 shows us that the current change is given by:

$$\Delta I = \frac{dI_{TFT}}{dV} \Delta V - \frac{dI_{TFT}}{dV} \Delta V_a \quad (2)$$

where ΔV_a is the change in LED anode voltage shown in Figure 4, and the differential is simply the gradient of the TFT characteristic $\lambda(I)$. The LED characteristic is given by $I_{LED} = f(V_a)$ so we find ΔV_a by differentiating the LED characteristic i.e.

$$\Delta I = \frac{df}{dV} \Delta V_a = \mu(I) \Delta V_a \quad (3)$$

using equations (2) and (3):

$$\Delta I = \frac{\lambda(I)}{\left(1 + \frac{\lambda(I)}{\mu(I)}\right)} \Delta V \quad (4)$$

For the purpose of this analysis it can be assumed that the current dependence of these parameters is dependent upon the current $I(r)$. Therefore, by substituting (4) into (1a):

$$I_{av}(r) = I(r) + \frac{1}{N} \frac{\lambda(I(r))}{\left(1 + \frac{\lambda(I(r))}{\mu(I(r))}\right)} \sum_{j=r+1}^{r+N-1} \Delta V(r, j) \quad (5)$$

The change in voltage is given by

$$\Delta V(r, j) = V(r, r) - V(r, j) \quad (6)$$

where $V(r,r)$ is the power line voltage drop at row r when row r is addressed and $V(r,j)$ is the power line voltage drop at row r when row j is addressed.

The analysis below assumes that the power line is held at a fixed voltage at the top and bottom. However, it will be appreciated that the analysis can however be performed for a power supply column held at one end. Thus, in this analysis, the power line is assumed to comprise a column that has voltage sources at both ends of the column to supply current to every pixel in the column. Initially, it can be assumed that every pixel contains a perfect current source drawing current from the power line and providing it to the OLED. The equivalent circuit for the model is shown in Figure 6.

The following expression can be derived for the current to the pixel at row r in terms of the voltages on the power line at rows $r-1$, r and $r+1$. The resistance of the power line between nodes is R .

$$\begin{aligned}
 I(r) &= \frac{1}{R}(V(r-1) - V(r)) + \frac{1}{R}(V(r+1) - V(r)) \\
 &= \frac{1}{R}(V(r-1) - 2V(r) + V(r+1))
 \end{aligned}
 \tag{7}$$

The current $I(r)$ is known as this has been programmed into the pixel current source so the need is to solve (1) for the voltage $V(r)$ to calculate the power line voltage drops. Writing out all the terms:

$$\begin{aligned}
 I(0)R &= V_T - 2V(0) + V(1) \\
 I(1)R &= V(0) - 2V(1) + V(2) \\
 &\vdots \\
 I(N-1)R &= V(N-2) - 2V(N-1) + V_B
 \end{aligned}$$

Where V_T and V_B are the voltage sources at the top and bottom of the power line. Then in matrix form:

$$RI = M.V + V_b \tag{8}$$

where

$$\mathbf{M}^{-1} = -\frac{1}{N+1} \begin{bmatrix} N & (N-1) & (N-2) & \cdots & 3 & 2 & 1 \\ (N-1) & 2(N-1) & 2(N-2) & & 6 & 4 & 2 \\ (N-2) & 2(N-2) & 3(N-2) & & 9 & 6 & 3 \\ \vdots & & & \ddots & & & \vdots \\ 3 & 6 & 9 & & 3(N-2) & 2(N-2) & (N-2) \\ 2 & 4 & 6 & & 2(N-2) & 2(N-1) & (N-1) \\ 1 & 2 & 3 & \cdots & (N-2) & (N-1) & N \end{bmatrix}$$

5 Also, computing the result of \mathbf{M}^{-1} on vector \mathbf{V}_b gives the result

$$\sum_{j=0}^{N-1} M^{-1}(n, j) V_b(j) = \frac{1}{N+1} \{(N-n)V_T + (n+1)V_B\} \quad (9a)$$

which simplifies to V when $V_T = V_B = V$.

10

Therefore:

$$V(r, r) = R \left[WM^{-1}(r, r)I(r, r) + \sum_{k=0}^{N-1} M^{-1}(r, k)I(k, r) \right]$$

$$V(r, j) = R \left[WM^{-1}(r, j)I(j, j) + \sum_{k=0}^{N-1} M^{-1}(r, k)I(k, j) \right]$$

15 where $M^{-1}(r, k)$ are matrix elements of \mathbf{M}^{-1} . In these equations, the constants resulting from the multiplication $\mathbf{M}^{-1} \cdot \mathbf{V}_b$ are ignored, as the equations are then used to derive difference voltages, so that the constants cancel out. The voltage differences are then given by:

$$\Delta V(r, j) = R \left[W \left(M^{-1}(r, r)I(r, r) - M^{-1}(r, j)I(j, j) \right) + \sum_{k=0}^{N-1} M^{-1}(r, k) (I(k, r) - I(k, j)) \right] \quad (10)$$

20

Vertical cross-talk can be considered to be at its most visible when the image is static from one field to the next. For moving images, the movement disguises the cross talk. The mathematical analysis for the compensation of cross talk for static images is more easily carried out, and this analysis is given

below. However, it is possible to carry out a different analysis to arrive at a slightly different cross talk correction scheme. The invention encompasses all of the different possible correction schemes, provided the compensation takes into account the column power supply line voltage at each pixel and the
 5 dependency of the pixel brightness characteristics on the voltage on the column power supply line at the pixel.

Mathematically the static field condition is represented by:

$$I(r, j) = I(r - N, j)$$

i.e. the pixel current in the current field is equal to the current in the
 10 previous field. This will mean that vectors $\mathbf{I}(r)$ and $\mathbf{I}(j)$ become

$$\mathbf{I}(r) = \begin{bmatrix} I(0, r) \\ I(1, r) \\ \vdots \\ (W+1)I(r, r) \\ I(r+1, r) \\ \vdots \\ I(N-1, r) \end{bmatrix}, \quad \mathbf{I}(j) = \begin{bmatrix} I(0, j) \\ I(1, j) \\ \vdots \\ (W+1)I(j, j) \\ I(j+1, j) \\ \vdots \\ I(N-1, j) \end{bmatrix}$$

The second index in the current no longer matters because (to a first approximation, ignoring the effect of cross-talk) the current in the pixel on line r
 15 is the same in both fields no matter what line is being addressed. Hence

$$\Delta V(r, j) = WR(M^{-1}(r, r)I(r) - M^{-1}(r, j)I(j)) \quad (11)$$

Therefore the vertical cross-talk is given by

$$\begin{aligned} I_{av}(r) &= I(r) + \frac{1}{N} \frac{\lambda(I(r))}{\left(1 + \frac{\lambda(I(r))}{\mu(I(r))}\right)} \sum_{j=r+1}^{r+N-1} WR(M^{-1}(r, r)I(r) - M^{-1}(r, j)I(j)) \\ &= I(r) + \frac{RW\lambda(I(r))}{\left(1 + \frac{\lambda(I(r))}{\mu(I(r))}\right)} \left(M^{-1}(r, r)I(r) - \frac{1}{N} \sum_{j=0}^{N-1} M^{-1}(r, j)I(j) \right) \end{aligned} \quad (12)$$

To perform a correction we need to find currents $I(r)$ that will result in an image without vertical cross-talk. This requires the inversion of equation (12) i.e. solve (12) for $I(r)$. This is a non-linear problem that is very difficult to solve, to enable a solution we assume that $\lambda(I)$ and $\mu(I)$ are functions of I_{av} rather than I i.e. $\lambda(I_{av})$ and $\mu(I_{av})$. If we represent equation (12) in a vector matrix form then a solution can be seen.

$$\mathbf{I}_{av} = \mathbf{I} + \mathbf{RWD} \left(\mathbf{M}_D^{-1} \mathbf{I} - \frac{1}{N} \mathbf{M}^{-1} \mathbf{I} \right) \tag{13}$$

The term

$$\mathbf{D} = \frac{\lambda(\mathbf{I}_{av})}{\left(1 + \frac{\lambda(\mathbf{I}_{av})}{\mu(\mathbf{I}_{av})} \right)}$$

is a diagonal matrix and \mathbf{M}_D^{-1} is also a diagonal matrix containing the diagonal terms in matrix \mathbf{M}^{-1} . Then we can solve for \mathbf{I}

$$\begin{aligned} \mathbf{I} &= \left(\mathbf{1} + \mathbf{RWD} \left(\mathbf{M}_D^{-1} - \frac{1}{N} \mathbf{M}^{-1} \right) \right)^{-1} \mathbf{I}_{av} \\ &\approx \mathbf{I}_{av} - \mathbf{RWD} \left(\mathbf{M}_D^{-1} \mathbf{I}_{av} - \frac{1}{N} \mathbf{M}^{-1} \mathbf{I}_{av} \right) \end{aligned} \tag{14}$$

Equation (14) represents the currents required to approximately remove vertical cross-talk. The calculation has to be performed for every column in the display.

This analysis is for a matched current mirror circuit, but the constant W allows the analysis to cover different types of circuit giving different current drawing characteristics during addressing.

An implementation of the invention will now be described. Essentially, this implementation requires calculation of the terms making up equation (14). This calculation is carried out in steps:

Step 1

This requires the calculation of $\mathbf{M}^{-1} \mathbf{I}_{av}$.

The implementation of $\mathbf{M}^{-1} \mathbf{I}_{av}$ could in general be a very computationally expensive calculation, especially for large images. Therefore a fast method of performing the calculation is essential. As seen above, the calculation of $\mathbf{M}^{-1} \mathbf{I}_{av}$

requires the evaluation of the sums shown below (index c is the column number):

$$F(c, n) = \sum_{j=0}^{n-1} (n-j) I_{av}(c, j) - \frac{n+1}{N+1} \sum_{j=0}^{N-1} (N-j) I_{av}(c, j) \quad (15)$$

5

By calculating the difference of $F(c, n)$ and $F(c, n-1)$ a recursive relation for the elements $F(c, n)$ can be found :

$$F(c, n) = \sum_{j=0}^{n-1} (n-j) I_{av}(c, j) - \frac{n+1}{N+1} \sum_{j=0}^{N-1} (N-j) I_{av}(c, j)$$

10

$$F(c, n-1) = \sum_{j=0}^{n-2} (n-1-j) I_{av}(c, j) - \frac{n}{N+1} \sum_{j=0}^{N-1} (N-j) I_{av}(c, j)$$

By expanding the subtraction $F(c, n) - F(c, n-1)$, the following recursive relation is obtained:

15

$$F(c, n) = F(c, n-1) + \sum_{j=0}^{n-1} I_{av}(c, j) + F(c, 0) \quad (16)$$

where

$$F(c, 0) = \frac{-1}{N+1} \sum_{j=0}^{N-1} (N-j) I_{av}(c, j) \quad (17)$$

This calculation is required on all columns of the display.

If we call the term in brackets in equation (14) $B(c, n)$ then

25

$$B(c, n) = \begin{cases} F(c, n) - F(c, n)/N & \text{if } c = n \\ -F(c, n)/N & \text{if } c \neq n \end{cases}$$

This can be seen when considering that \mathbf{M}^{-1}_D has only diagonal entries, which are those of the matrix \mathbf{M}^{-1} .

5 Figure 7 shows the hardware to calculate the vector-matrix multiplication. The input data is fed to an adder 60 whose second input is from a line store 62 addressed by a counter counting the row number (j). Each value in the line store 62 contains a running sum of the previous data values on the column for a particular column. This line store will be zero after each field of data. The output
10 of the sum is passed back to the line store 62 to overwrite the previous value stored at the location addressed. It is also passed to a field store 64 with rows 0 to N-1 and columns 0 to C-1. The field store is addressed by a line counter counting the value c from 0 to C-1, where c is the pixel number within a line (row) and a row counter counting the value n from 0 to N-1, where n is the line
15 (row) number. The values of c and n determine the location of the partial sum. At the end of a field time the partial sum data is transferred in parallel a row at a time to a line store 66, and this data will be used in the computation of equation (16).

The input data is also fed to a multiplier 70 whose second input comes
20 from a counter 72 that counts down from N at the start of a field and increments every line time. The output of the multiplier is passed to an adder 74 whose second input comes from a line store 76 whose elements contains the running sums of the earlier inputs to the multiplier for every column. This line store 76 is set to zero at the beginning of a field time. A counter counting the pixel number
25 within a line again addresses the line store 76.

The output of the adder 74 is fed back to the addressed location of the line store 76 to overwrite the previous value. At the end of the field, the values in the line store 76, which is then the full summation value shown in box 78, are all multiplied by the same constant $-1/(N+1)$ which is stored as shown at 80.
30 The result is written to another line store 82. The results stored in the line store 82 are the values $F(c,0)$ of equation (16).

The value $F(c,0)$ is thus available, and the partial sum data required to calculate $F(c,n)$.

The calculation of $F(c,n)$ is achieved by addressing the line store 82 containing $F(c,0)$ and the line store 66 containing the partial sum data and adding the data to the output of a further line store 84 containing $F(c,n-1)$. The result, at the output of adder 87, constitutes $F(c,n)$ and is also written back into the addressed location of the $F(c,n-1)$ line store to overwrite the stored value.

This summed value is then multiplied by the constant $-1/N$ stored in block 86 and passed to another adder 88. The second input to the adder 88 comes from a decision block 90, if $n = c$ then the value $F(c,n)$ is passed to the adder, otherwise zero is passed.

The output of the adder 88 is the result of this processing block $B(c,n)$ and corresponds to the terms in brackets in equation 14.

15 Step 2

The remaining parts of the algorithm can be implemented as shown in Figure 8. The input data passes through a field delay store 100 and onto a look up table (LUT) 102 to find the value of $WR\lambda/(1+\lambda/\mu)$ corresponding to that input data value. The output of the field store is also passed to the subtraction unit 106. The output of the LUT 102 is multiplied by the output of step 1 ($B(c,n)$) and also passed to the subtraction unit 106. The result is then the corrected data.

This data processing will fit into the total video processing chain, preferably at the end of the processing chain, namely after all other data modifications have been performed.

As the OLED characteristic will vary according to temperature and age will also be possible to update the LUT 102 of Figure 8 with new values to represent these changes. The LUT will need changing for different types of AMOLED display through parameter W e.g. matched TFT to driving TFT width, or if the row resistance R changes for different manufactures or for different TFT output impedance characteristics. Therefore the LUT will need to be accessible and updateable.

The above analysis is for a current mirror type circuit. There are other circuits and addressing schemes which can benefit from the compensation scheme of the invention. These addressing techniques may use different techniques to avoid cross-talk that occurs from the corruption of the in-pixel data voltage. However cross-talk will still appear due to the TFT output impedance. Generally, addressing schemes have an addressing phase and a light emission phase, and this is to stop current flowing on the power lines when the pixels are being addressed. Cross-talk again results from addressing a display in this manner as a result of the currents flowing along the power column.

The technique of the invention is thus not limited to current addressed pixels, but can be used more generally whenever a column power supply line is used. The invention can be applied to voltage-addressed pixels using column power lines, and these pixels may have other compensation measures already integrated into the pixel design. The invention provides modified target currents for the pixels. In the case of current-addressed pixels, this means the currents used to address the pixels are then changed. In the case of voltage addressed pixels, the modified target currents are then converted back to voltage drive levels for the pixels, for example using the basic model of the pixel characteristics.

A simplified correction scheme can be derived from equation (4) above. In the general case, it can be assumed that the current drawn during addressing is αI where I is the addressing current. For a scheme where no current flows during addressing, $\alpha = 0$, and a simplified algorithm can be derived, as will shown below.

If the initial voltages on the power line are caused by addressing currents αI there are voltage drops in the addressing period of

$$V_i = \mathbf{M}^{-1}(\alpha \mathbf{R} \mathbf{I} - \mathbf{V}_b) \quad (18)$$

30

if after addressing, the currents are I , then the power line voltage drops become

$$\mathbf{V}_f = \mathbf{M}^{-1}(\mathbf{R}\mathbf{I} - \mathbf{V}_b) \quad (19)$$

therefore the difference in power line voltages are

5

$$\Delta\mathbf{V} = (1 - \alpha)\mathbf{R}\mathbf{M}^{-1}\mathbf{I} \quad (20)$$

Example values for α are zero for modified current source and voltage threshold measurement circuits, 1 for switched current mirrors (i.e. no cross-talk, but these pixel circuits are unsuitable for large displays), and greater than or equal to two for matched current mirror circuits. The greater than two case will occur if the matched TFT is wider than the driving TFT.

The initial currents \mathbf{I}_0 on the row (after addressing) will cause a voltage drop of $\Delta\mathbf{V}$ which in turn will cause \mathbf{I}_0 to change to \mathbf{I}_1 which will change the voltage drops which will change the current and so on. It is expected that λ will be very small so a first order approximation is sufficient i.e.

$$\mathbf{I}_1 = \mathbf{I}_0 + \frac{\lambda(\mathbf{I}_0)}{\left(1 + \frac{\lambda(\mathbf{I}_0)}{\mu(\mathbf{I}_0)}\right)}(1 - \alpha)\mathbf{R}\mathbf{M}^{-1}\mathbf{I}_0 \quad (21)$$

20

It can again be assumed that μ and λ depend upon the known current \mathbf{I}_1 . This will be a good approximation if the current changes between \mathbf{I}_1 and \mathbf{I}_0 are small. The solution of equation (21) is then:

$$\begin{aligned} \mathbf{I}_0 &= \left(\mathbf{1} + \frac{\lambda(\mathbf{I}_1)}{\left(1 + \frac{\lambda(\mathbf{I}_1)}{\mu(\mathbf{I}_1)}\right)}(1 - \alpha)\mathbf{R}\mathbf{M}^{-1} \right)^{-1} \mathbf{I}_1 \\ &\approx \mathbf{I}_1 - \frac{\lambda(\mathbf{I}_1)}{\left(1 + \frac{\lambda(\mathbf{I}_1)}{\mu(\mathbf{I}_1)}\right)}(1 - \alpha)\mathbf{R}\mathbf{M}^{-1}\mathbf{I}_1 \end{aligned} \quad (22)$$

Assuming $\alpha=0$, in order to show a simplified algorithm solution:

$$I_0 \approx I_1 - \frac{\lambda(I_1)}{\left(1 + \frac{\lambda(I_1)}{\mu(I_1)}\right)} RM^{-1} I_1 \quad (23)$$

I_1 is the input data and I_0 is the corrected data. The hardware
 5 implementation for this case ($\alpha=0$) is very similar to that above for the matched
 current mirror (typically $\alpha=1$), and is shown in Figures 9 and 10 using the same
 references as in Figures 7 and 8.

In Figure 9, the output of the circuit for "step 1" is the value $F(c,n)$,
 namely the output of adder 87. There is no need for the logic element 90 and
 10 associated adder and multiplier. The values of $F(c,n)$ can then be provided to
 the multiplier 104 in Figure 10. The LUT 102 in Figure 10 no longer uses the
 parameter "W".

The AMOLED display is typically constructed with additional pixel circuits
 outside the array and which are used for testing purposes. These may take the
 15 form shown in Figure 11, and essentially model the behaviour of the drive
 transistor characteristics and of the row conductor resistance. These dummy
 pixel circuits have been proposed for use in threshold compensation schemes.
 The use of these dummy pixel circuits makes it possible to automatically
 generate and update the LUT over the lifetime of the display.

Figure 11 shows a dummy pixel 110 with an n-type transistor, a dummy
 20 pixel 112 with a p-type transistor and a resistor 114 which can be used to model
 the row conductor characteristics. Each circuit has terminals which allow test
 signals to be applied and outputs to be monitored. The PCMs shown in Figure
 11 are on the glass. There will be an n-type circuit for amorphous silicon
 25 circuits and a p-type circuit for low temperature polysilicon (LTPS) circuits or a
 combination of n-type and p-type circuits for LTPS circuits.

The TFT output impedance as a function of current can be measured by
 varying the gate-source voltage of the TFT and measuring the current and the
 drain-source voltage of the TFT from the appropriate probe points on the circuit.
 30 Then the gradient of the data will be required to give λ . The same can be

achieved for the OLED to give μ . R can be determined by passing a current through a strip of metal N pixel lengths long and measuring the voltage to calculate the resistance in a pixel width strip of power line metal.

5 The display type will be dictate the value W in the example of matched current mirror circuit above. All of this information enable the LUT to be calculated and updated through the lifetime of the display. The hardware to perform the measurements is straightforward and would possibly be included within the display driver chips. These would feed back the measured data to hardware in a controller chip to calculate the LUT and fill it.

10 Only one detailed algorithm has been given, and some assumptions have been made to simplify the implementation of the method. Other assumptions may be made to arrive at a different algorithmic implementation, and the invention is not limited to the specific implementation described above.

15 The hardware example has been described as having numerous registers and logic elements. Many or all of the elements can be integrated into a dedicated processor architecture, and the hardware example is only one way of implementing the correction scheme of the invention.

Other modifications will be apparent to those skilled in the art.

CLAIMS

1. A method of determining the pixel drive signals to be applied to the pixels of an array of light emitting display elements (2) arranged in rows and columns, with a plurality of the pixels in a column being supplied with current from a respective column power supply line (26) and the pixels being addressed row by row, the addressing of all rows defining a field period, the method comprising:

determining target pixel drive currents corresponding to desired pixel brightness levels based on a model of the pixel current-brightness characteristics;

modifying the target pixel drive currents to take account of:

the voltage on the column power supply line (26) at each pixel resulting from the currents drawn from the column power supply line (26) by the plurality of pixels in the column for each row addressing cycle in a field period; and

the dependency of the pixel brightness characteristics on the voltage on the column power supply line at the pixel.

2. A method as claimed in claim 1, wherein each pixel is programmed in a first phase and driven in a second phase, and wherein the step of modifying the target pixel drive currents further takes account of any differences in the current drawn by the pixels between the first and second phases.

3. A method as claimed in any preceding claim, wherein the step of modifying the target pixel drive currents comprises:

applying an algorithm to the target pixel drive currents which represents:

the relationship between the currents applied to the pixels in a column during a field period and the voltages on the column power supply line at the locations of the pixels; and

the dependency of the pixel brightness characteristics on the voltage on the column power supply line.

4. A method as claimed in claim 3, wherein applying an algorithm comprises multiplying a vector of the target pixel drive currents for a column of pixels by the inversion of the matrix **M**, in which:

$$\mathbf{M} = \begin{bmatrix} -2 & 1 & & & \\ 1 & -2 & 1 & & \\ & \ddots & \ddots & \ddots & \\ & & 1 & -2 & 1 \\ & & & 1 & -2 \end{bmatrix},$$

and wherein the number of rows and columns of matrix **M** is equal to the number of pixels in the column.

5. A method as claimed in claim 3 or 4, wherein each pixel comprises a current sampling transistor (34) which samples an input current and provides a drive voltage to a drive transistor (22), and wherein the algorithm uses a value including terms derived from:

the voltage-current characteristics of the drive transistor (22); and

the voltage-current characteristics of the light emitting display element (2).

6. A method as claimed in claim 5, wherein the algorithm uses a value including a term (R) derived from the resistance of the column power supply line.

7. A method as claimed in claim 6, wherein the algorithm uses a value $R\lambda/(1+\lambda/\mu)$, where

R is the resistance of the column power supply line between adjacent pixels;

λ is the slope of the drain-source current vs. drain-source voltage curve of the drive transistor; and

μ is the slope of the current vs. voltage curve of the display element.

5 8. A method as claimed in claim 7, wherein the value $R\lambda/(1+\lambda/\mu)$ uses the slope of the drain-source current vs. drain-source voltage curve of the drive transistor (22) and the slope of the current vs. voltage curve of the display element at the target pixel drive current.

10 9. A method as claimed in claim 4, wherein the result of multiplying a vector of the target pixel drive currents for a column of pixels by the inversion of the matrix **M** is obtained by a recursive operation

$$F(c, n) = F(c, n-1) + \sum_{j=0}^{n-1} I_{av}(c, j) + F(c, 0)$$

15 in which:

$F(c, n)$ is the n th term of the vector result of multiplying the vector of the target pixel drive currents for the c th column of pixels by the inversion of the matrix **M**, $F(c, 0)$ being the first term; and

20 $I_{av}(c, j)$ is the target current for the j th pixel in the c th column, the first pixel being $j=0$.

10. A method as claimed in claim 9, wherein:

$$F(c, 0) = \frac{-1}{N+1} \sum_{j=0}^{N-1} (N-j) I_{av}(c, j),$$

in which:

25 N is the total number pixels in the column.

11. A method as claimed in any one of claims 3 to 10, wherein the values representing the dependency of the pixel brightness characteristics on the voltage on the column power supply line are stored in a look up table (102).

12. A method as claimed in claim 11, wherein the look up table (102) stores the values for a range of current values.

13. A method as claimed in claim 11 or 12, wherein the values of the look up table (102) are updated over time to enable changes in pixel brightness characteristics over time to be modeled.

14. A method as claimed in claim 13, wherein updating of the look up table values is carried out based on analysis of the characteristics of pixel compensation modules (110,112,114) of the display.

15. A method of driving an active matrix array of current-addressed light emitting display elements (2) arranged in rows and columns, comprising addressing each row of pixels in a sequence and providing power to each column of pixels using a column power supply line (26), the method comprising, for all pixels:

determining pixel drive signals for each pixel in each column using the method of any one of the preceding claims; and

applying the pixel drive signals to data columns of the display during a pixel programming phase for each row of pixels.

16. A display device comprising an array of light emitting display elements (2) arranged in rows and columns, with a plurality of the pixels in a column being supplied with current from a respective column power supply line (26) and the pixels being addressed row by row, the addressing of all rows defining a field period, the device further comprising:

compensation circuitry for modifying target pixel drive currents to take account of the voltage on the column power supply line at each pixel resulting from the currents drawn from the column power supply line by the plurality of pixels in the column for each row addressing cycle in a field period and the dependency of the pixel brightness characteristics on the voltage on the row conductor at the pixel.

17. A device as claimed in claim 16, wherein the compensation circuitry comprises:

means for applying an algorithm to the target pixel drive currents which represents the relationship between the currents drawn by the pixels in a column and the voltages on the column power supply line at the locations of the pixels and the dependency of the pixel brightness characteristics on the voltage on the row conductor.

18. A device as claimed in claim 17, wherein the means for applying an algorithm derives values corresponding to multiplying a vector of the target pixel drive currents for a column of pixels by the inversion of the matrix **M**, in which:

$$\mathbf{M} = \begin{bmatrix} -2 & 1 & & & \\ 1 & -2 & 1 & & \\ & \ddots & \ddots & \ddots & \\ & & 1 & -2 & 1 \\ & & & 1 & -2 \end{bmatrix},$$

15

and wherein the number of rows and columns of matrix **M** is equal to the number of pixels in the column.

19. A device as claimed in claim 17 or 18, wherein each pixel comprises a current sampling transistor (34) which samples an input current and provides a drive voltage to a drive transistor (22), and wherein the algorithm uses a value including terms derived from:

the voltage-current characteristics of the drive transistor (22); and

the voltage-current characteristics of the light emitting display element

(2).

20. A device as claimed in claim 19, wherein the drive transistor (22) and the light emitting display element (2) of each pixel are in series between the column power supply line (26) and a common line.

21. A device as claimed in any one of claims 17 to 20, wherein the algorithm uses a value including a term (R) derived from the resistance of the column power supply line (26).

5

22. A device as claimed in claim 21, wherein the algorithm uses a value $R\lambda/(1+\lambda/\mu)$, where

R is the resistance of the column power supply line between adjacent pixels;

10 λ is the slope of the drain-source current vs. drain-source voltage curve of the drive transistor; and

μ is the slope of the current vs. voltage curve of the display element.

23. A device as claimed in claim 22, wherein the value $R\lambda/(1+\lambda/\mu)$
 15 uses the slope of the drain-source current vs. drain-source voltage curve of the drive transistor and the slope of the current vs. voltage curve of the display element at the target pixel drive current.

24. A device as claimed in claims 18, wherein the means for applying
 20 an algorithm derives values by a recursive operation

$$F(c, n) = F(c, n-1) + \sum_{j=0}^{n-1} I_{av}(c, j) + F(c, 0)$$

in which:

25 $F(c, n)$ is the nth term of the vector result of multiplying the vector of the target pixel drive currents for the cth column of pixels by the inversion of the matrix **M**, $F(c, 0)$ being the first term; and

$I(c, j)$ is the target current for the jth pixel in the cth column, the first pixel being $j=0$.

30 25. A device as claimed in claim 24, wherein:

$$F(c,0) = \frac{-1}{N+1} \sum_{j=0}^{N-1} (N-j) I_{av}(c, j),$$

in which:

N is the total number pixels in the column.

5 26. A device as claimed in any one of claims 17 to 25, wherein the means for applying an algorithm comprises a look up table (102).

10 27. A device as claimed in claim 26, further comprising at least one pixel compensation module (110,112,114), and further comprising means for updating the values of the look up table to enable changes in pixel brightness characteristics over time to be modeled based on analysis of the characteristics of the pixel compensation module.

15 28. A circuit for generating pixel drive currents for the display elements of a light emitting display device having display elements arranged in rows and columns, with a plurality of the pixels in a column being supplied with current from a respective column power supply line (26) and the pixels being addressed row by row, the addressing of all rows defining a field period, the circuit comprising:

20 means for receiving target pixel drive currents;
 compensation circuitry for modifying the target pixel drive currents to take account of the voltage on the column power supply line at each pixel resulting from the currents drawn from the column power supply line by the plurality of pixels in the column for each row addressing cycle in a field period and the
25 dependency of the pixel brightness characteristics on the voltage on the row conductor at the pixel.

 29. A circuit as claimed in claim 28, wherein the compensation circuitry comprises:

30 means for applying an algorithm to the target pixel drive currents which represents the relationship between the currents drawn by the pixels in a

column and the voltages on the column power supply line at the locations of the pixels and the dependency of the pixel brightness characteristics on the voltage on the row conductor.

- 5 30. A circuit as claimed in claim 29, wherein the means for applying an algorithm derives values corresponding to multiplying a vector of the target pixel drive currents for a column of pixels by the inversion of the matrix **M**, in which:

$$\mathbf{M} = \begin{bmatrix} -2 & 1 & & & \\ 1 & -2 & 1 & & \\ & \ddots & \ddots & \ddots & \\ & & 1 & -2 & 1 \\ & & & 1 & -2 \end{bmatrix},$$

10

and wherein the number of rows and columns of matrix **M** is equal to the number of pixels in the column.

- 15 31. A circuit as claimed in claim 30, wherein the algorithm uses a value including a term (R) derived from the resistance of the column power supply line (26).

32. A circuit as claimed in claim 30, wherein the means for applying an algorithm derives values by a recursive operation

20

$$F(c,n) = F(c,n-1) + \sum_{j=0}^{n-1} I_{av}(c,j) + F(c,0)$$

in which:

25 F(c,n) is the nth term of the vector result of multiplying the vector of the target pixel drive currents for the cth column of pixels by the inversion of the matrix **M**, F(c, 0) being the first term; and

I(c,j) is the target current for the jth pixel in the cth column, the first pixel being j=0.

1/6

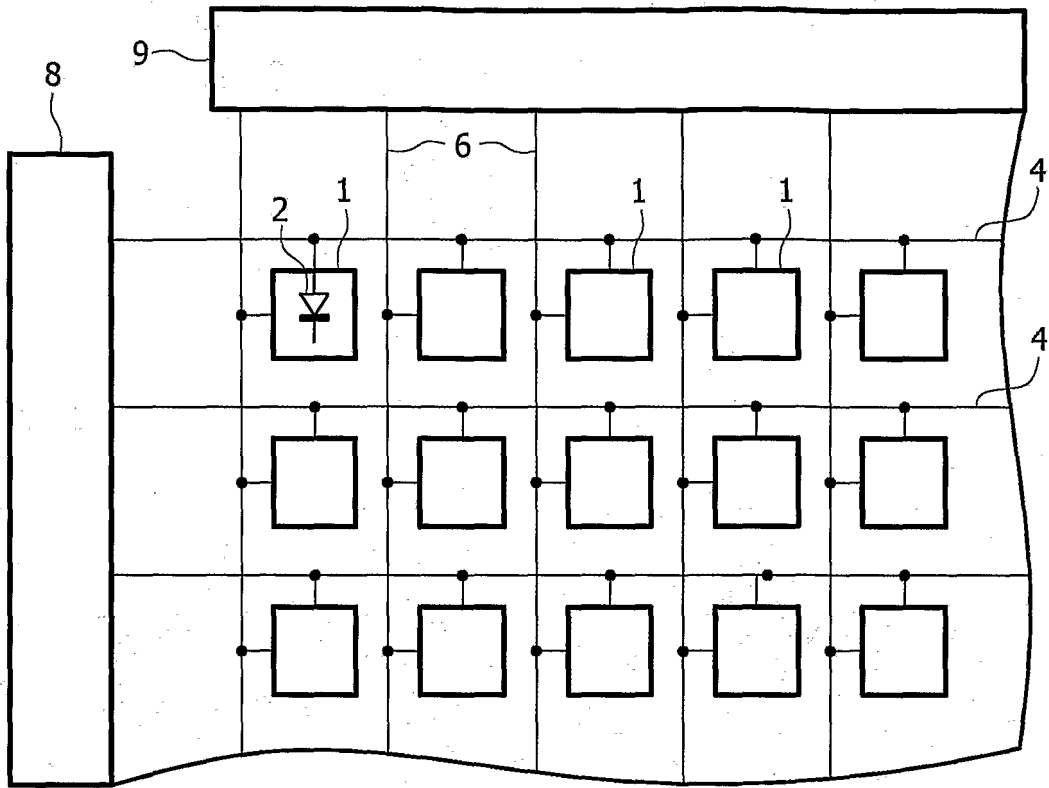

FIG. 1 PRIOR ART

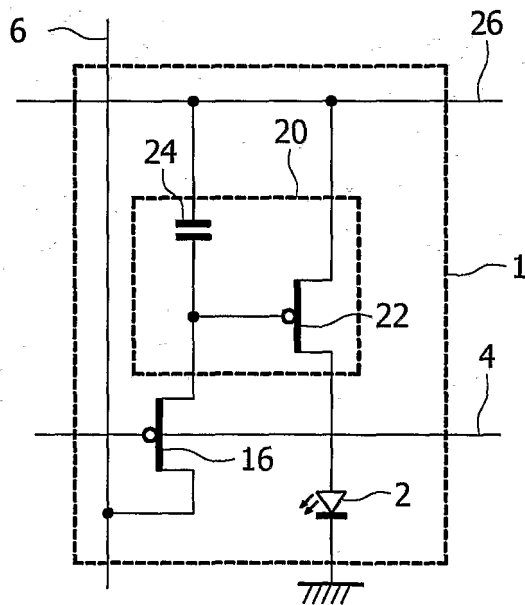

FIG. 2 PRIOR ART

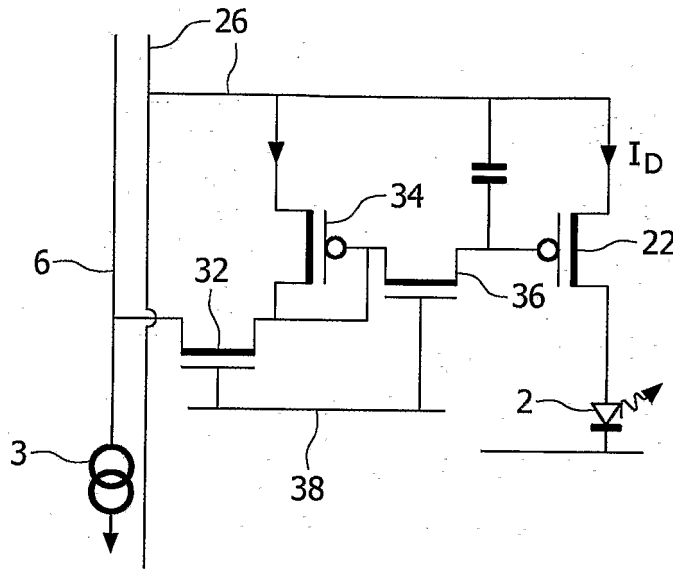

FIG. 3

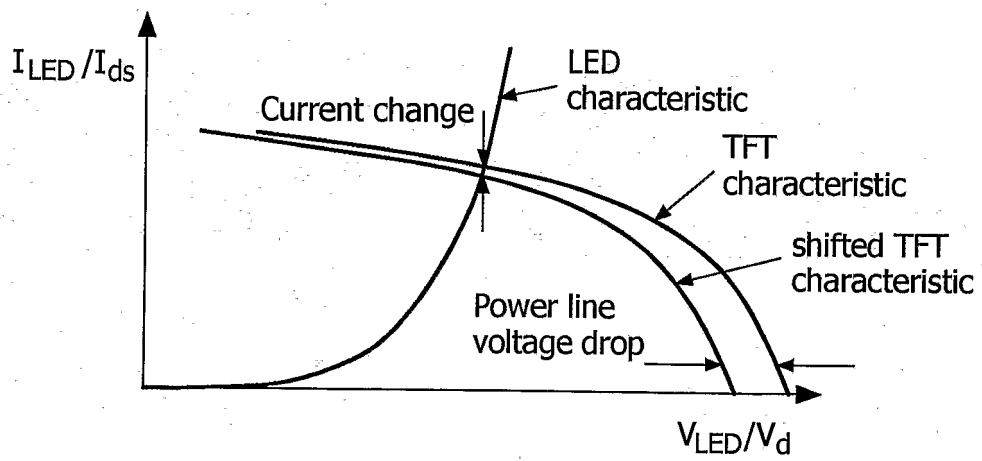

FIG. 4

3/6

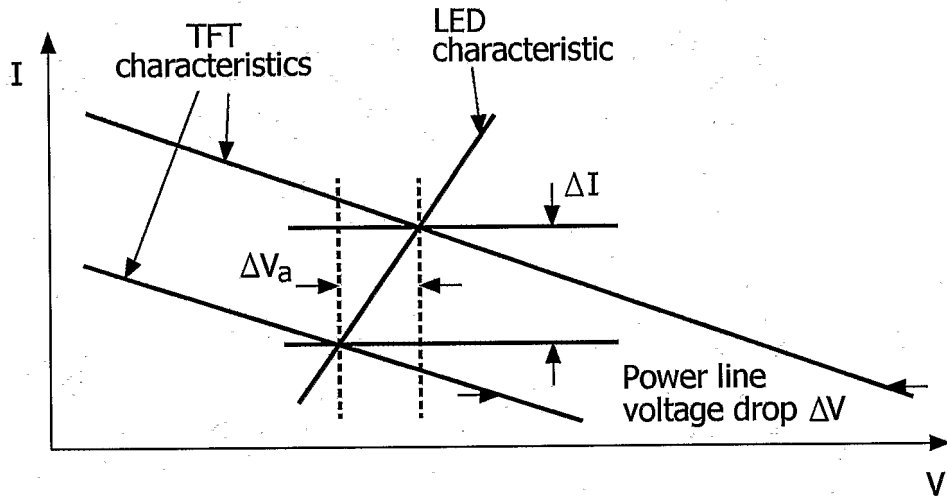

FIG. 5

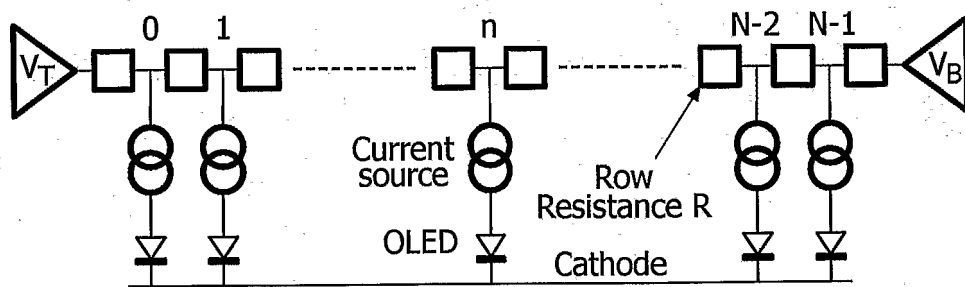

FIG. 6

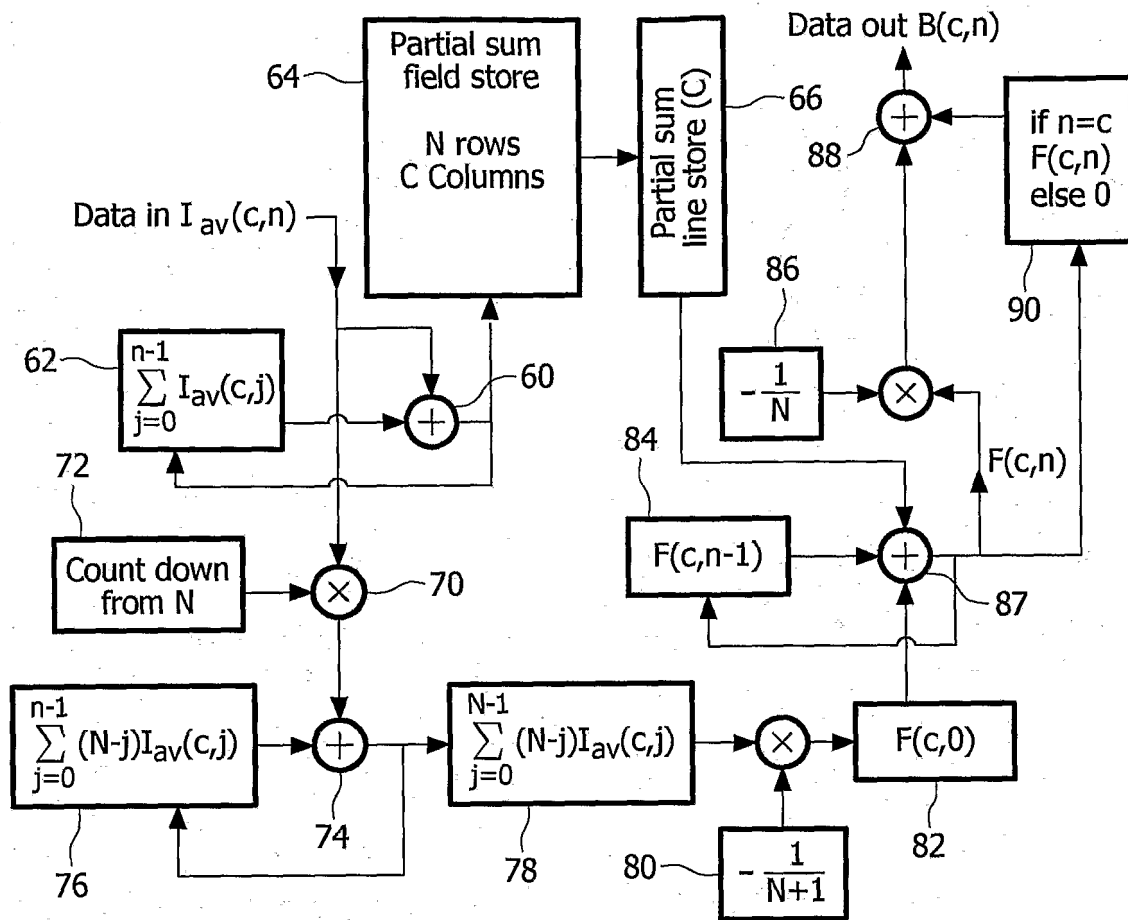

FIG. 7

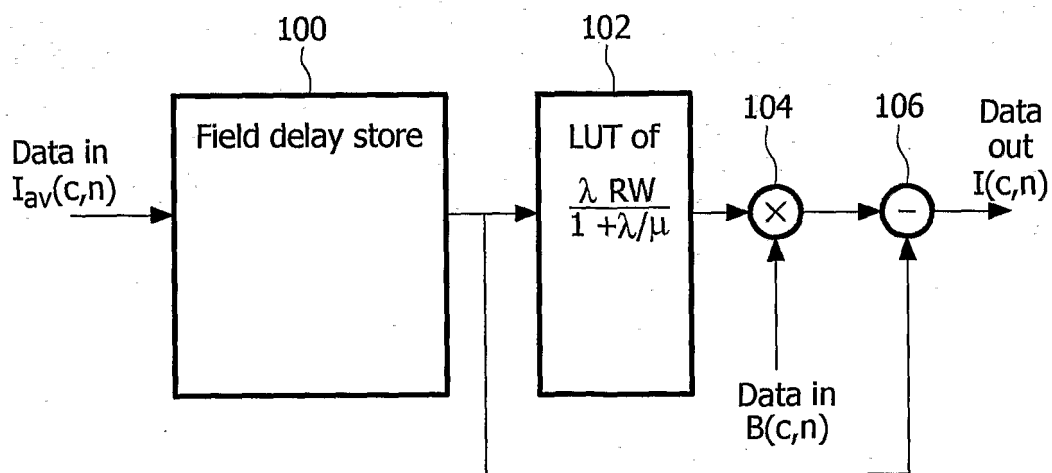

FIG. 8

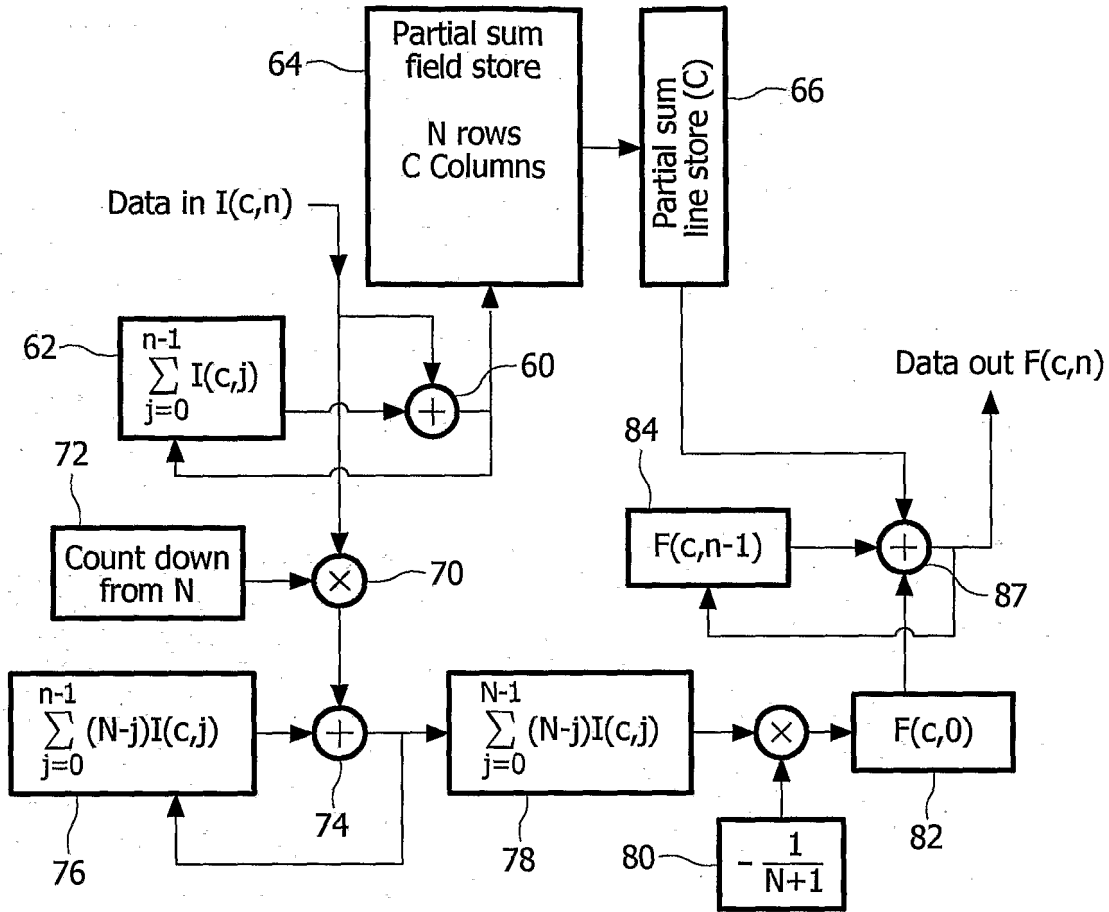

FIG. 9

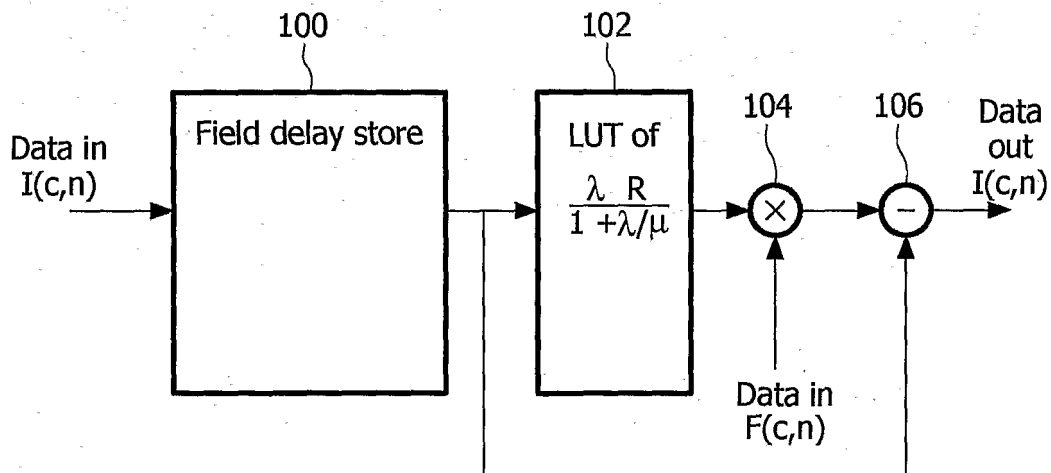

FIG. 10

6/6

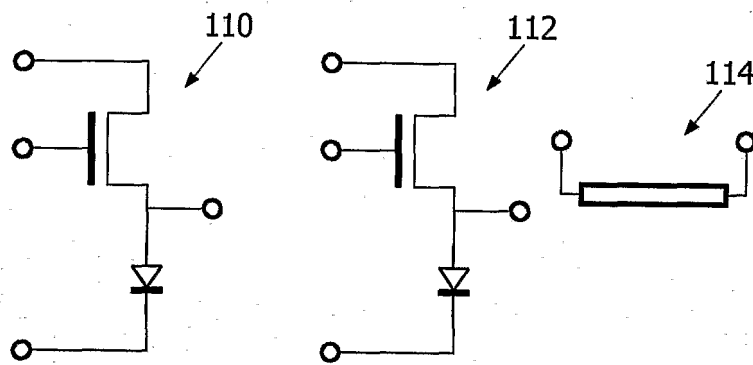

FIG. 11

INTERNATIONAL SEARCH REPORT

International Application No
PCT/IB2004/002729

A. CLASSIFICATION OF SUBJECT MATTER
IPC 7 G09G3/32 G09G3/00

According to International Patent Classification (IPC) or to both national classification and IPC

B. FIELDS SEARCHED
Minimum documentation searched (classification system followed by classification symbols)
IPC 7 G09G

Documentation searched other than minimum documentation to the extent that such documents are included in the fields searched

Electronic data base consulted during the international search (name of data base and, where practical, search terms used)
EPO-Internal

C. DOCUMENTS CONSIDERED TO BE RELEVANT

Category °	Citation of document, with indication, where appropriate, of the relevant passages	Relevant to claim No.
X	US 6 229 508 B1 (KANE MICHAEL GILLIS) 8 May 2001 (2001-05-08)	1-3, 5, 11-17, 19, 26-29
Y	column 4, line 62 - column 5, line 36 column 10, line 13 - column 11, line 21; figures 10, 11 column 12, line 6 - column 13, line 52; figures 2, 12, 13 column 16, line 19 - column 20, line 3; figures 14-23 ----- -/--	6-8, 20-23, 31

Further documents are listed in the continuation of box C. Patent family members are listed in annex.

° Special categories of cited documents :

A document defining the general state of the art which is not considered to be of particular relevance	*T* later document published after the international filing date or priority date and not in conflict with the application but cited to understand the principle or theory underlying the invention
E earlier document but published on or after the international filing date	*X* document of particular relevance; the claimed invention cannot be considered novel or cannot be considered to involve an inventive step when the document is taken alone
L document which may throw doubts on priority claim(s) or which is cited to establish the publication date of another citation or other special reason (as specified)	*Y* document of particular relevance; the claimed invention cannot be considered to involve an inventive step when the document is combined with one or more other such documents, such combination being obvious to a person skilled in the art.
O document referring to an oral disclosure, use, exhibition or other means	*&* document member of the same patent family
P document published prior to the international filing date but later than the priority date claimed	

Date of the actual completion of the international search 6 December 2004	Date of mailing of the international search report 14/12/2004
--	--

Name and mailing address of the ISA European Patent Office, P.B. 5818 Patentlaan 2 NL - 2280 HV Rijswijk Tel. (+31-70) 340-2040, Tx. 31 651 epo nl, Fax: (+31-70) 340-3016	Authorized officer Morris, D
--	-------------------------------------

INTERNATIONAL SEARCH REPORT

International Application No

PCT/IB2004/002729

C.(Continuation) DOCUMENTS CONSIDERED TO BE RELEVANT		
Category *	Citation of document, with indication, where appropriate, of the relevant passages	Relevant to claim No.
Y	US 5 774 100 A (AOKI YOSHIRO ET AL) 30 June 1998 (1998-06-30) column 7, line 47 - column 9, line 2 column 9, line 35 - column 9, line 46; figures 1,2 column 10, line 15 - column 11, line 35; figures 3-6 column 19, line 56 - column 20, line 43; figures 9,10	5-8, 19-23,31
X	US 2002/180672 A1 (KOYAMA JUN ET AL) 5 December 2002 (2002-12-05)	1-3, 11-17, 26-29
Y	paragraph '0124! - paragraph '0130!; figure 6 paragraph '0158! - paragraph '0171!; figures 7-9 paragraph '0360! - paragraph '0370!; figure 22	5-8,19, 31
A	US 5 751 279 A (OKUMURA FUJIO) 12 May 1998 (1998-05-12) column 5, line 17 - column 6, line 9; figures 1,2 column 6, line 20 - column 7, line 55; figures 3-5 column 8, line 7 - column 8, line 56; figure 6	1-3, 12-17, 28,29
A	US 5 805 130 A (FURUKAWA HIROYUKI ET AL) 8 September 1998 (1998-09-08) column 23, line 55 - column 26, line 56; figures 31-35	4-10, 18-24, 30,32
A	US 2003/034941 A1 (ALBU LUCIAN REMUS ET AL) 20 February 2003 (2003-02-20) paragraph '0022!; figure 2 paragraph '0028! - paragraph '0042!; figure 3	1-3, 12-17, 28,29
A	US 2002/186192 A1 (MAEDE TOSHIO ET AL) 12 December 2002 (2002-12-12) paragraph '0101! - paragraph '0110!; figures 11-15 paragraph '0113! - paragraph '0120!; figure 17	1-3, 12-17, 28,29

INTERNATIONAL SEARCH REPORT

Information on patent family members

International Application No

PCT/IB2004/002729

Patent document cited in search report		Publication date	Patent family member(s)	Publication date
US 6229508	B1	08-05-2001	US 2001024186 A1 EP 0905673 A1 JP 11219146 A	27-09-2001 31-03-1999 10-08-1999
US 5774100	A	30-06-1998	JP 9152629 A KR 222311 B1 US 2002047838 A1	10-06-1997 01-10-1999 25-04-2002
US 2002180672	A1	05-12-2002	JP 2001265283 A TW 480727 B US 2001028060 A1	28-09-2001 21-03-2002 11-10-2001
US 5751279	A	12-05-1998	JP 2848139 B2 JP 6035414 A	20-01-1999 10-02-1994
US 5805130	A	08-09-1998	JP 7294879 A JP 2892951 B2 JP 8146382 A CN 1114752 A , B	10-11-1995 17-05-1999 07-06-1996 10-01-1996
US 2003034941	A1	20-02-2003	EP 1435083 A1 WO 03017243 A1	07-07-2004 27-02-2003
US 2002186192	A1	12-12-2002	JP 2002366119 A CN 1391205 A TW 580680 B	20-12-2002 15-01-2003 21-03-2004

专利名称(译)	用于发光显示器的数据信号驱动器		
公开(公告)号	EP1661110A1	公开(公告)日	2006-05-31
申请号	EP2004769159	申请日	2004-08-20
[标]申请(专利权)人(译)	皇家飞利浦电子股份有限公司		
申请(专利权)人(译)	皇家飞利浦电子N.V.		
当前申请(专利权)人(译)	皇家飞利浦电子N.V.		
发明人	FISH, DAVID A., PHILIPS INTELLECTUAL PROP. & STD.		
IPC分类号	G09G3/32 G09G3/00		
CPC分类号	G09G3/006 G09G3/3233 G09G3/3283 G09G2300/0809 G09G2320/0209 G09G2320/0223 G09G2320/0285 G09G2320/029 G09G2320/043 G09G2330/12 G09G2360/16 G09G2360/18		
优先权	2003020212 2003-08-29 GB		
外部链接	Espacenet		

摘要(译)

显示器具有以行和列布置的发光元件 (2) , 其中列中的像素被从相应的列电源线 (26) 提供电流。基于像素电流 - 亮度特性的模型, 确定对应于期望像素亮度等级的目标像素驱动电流。这些被修改以考虑由列电源线引出的电流引起的每个像素处的列电源线 (26) 上的电压, 以及像素亮度特性对列电源线上的电压的依赖性在像素处。本发明解决了由于提供电流的TFT的有限输出阻抗以及用于形成电源线的金属的有限电阻而在有源矩阵LED显示器中发生的垂直串扰的问题。