



(11)

EP 3 667 756 A1

(12) **EUROPEAN PATENT APPLICATION**

(43) Date of publication:
17.06.2020 Bulletin 2020/25

(51) Int Cl.:
H01L 51/54^(2006.01)

(21) Application number: **19213201.7**

(22) Date of filing: **03.12.2019**

(84) Designated Contracting States:
AL AT BE BG CH CY CZ DE DK EE ES FI FR GB GR HR HU IE IS IT LI LT LU LV MC MK MT NL NO PL PT RO RS SE SI SK SM TR
Designated Extension States:
BA ME
Designated Validation States:
KH MA MD TN

(72) Inventors:
• **BAE, Suk-Young**
10845 Paju-si, Gyeonggi-do (KR)
• **SHIN, In-Ae**
10845 Paju-si, Gyeonggi-do (KR)
• **KIM, Jun-Yun**
10845 Paju-si, Gyeonggi-do (KR)
• **CHOE, Ik-Rang**
10845 Paju-si, Gyeonggi-do (KR)

(30) Priority: **13.12.2018 KR 20180160974**

(71) Applicant: **LG Display Co., Ltd.**
SEOUL, 07336 (KR)

(74) Representative: **Viering, Jentschura & Partner mbB**
Patent- und Rechtsanwälte
Am Brauhaus 8
01099 Dresden (DE)

(54) **DELAYED FLUORESCENT COMPOUND, AND ORGANIC LIGHT EMITTING DIODE AND ORGANIC LIGHT EMITTING DISPLAY DEVICE INCLUDING THE SAME**

(57) The present disclosure provides a delayed fluorescent compound of following Formula, and an organic light emitting diode (D) including a first electrode (160), a second electrode (164) and an organic emitting layer between the first and second electrodes (160, 164), where the delayed fluorescent compound is included in the organic emitting layer, and an organic light emitting display device (100) including the organic emitting compound.

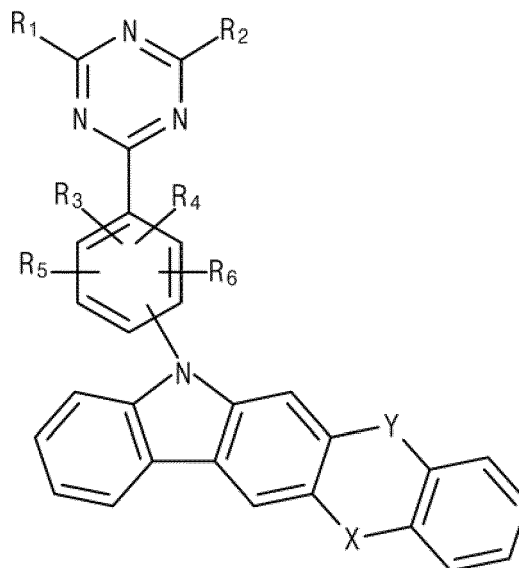
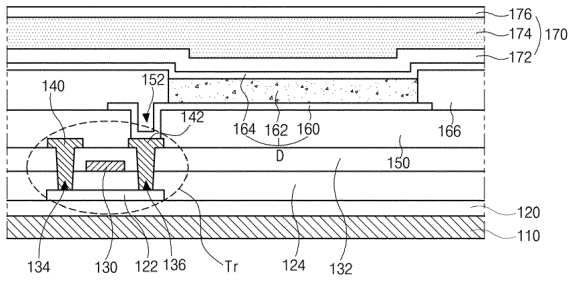

FIG. 1

100



Description

CROSS-REFERENCE TO RELATED APPLICATIONS

5 [0001] The present application claims the benefit of Korean Patent Application No. 10-2018-0160974 filed in the Republic of Korea on December 13, 2018.

BACKGROUND

10 FIELD OF TECHNOLOGY

[0002] The present disclosure relates to a delayed fluorescent compound, and more particularly, to a delayed fluorescent compound having high emitting efficiency and an organic light emitting diode and an organic light emitting display device including the same.

15

DISCUSSION OF THE RELATED ART

[0003] Recently, requirement for flat panel display devices having small occupied area is increased. Among the flat panel display devices, a technology of an organic light emitting display device including an organic light emitting diode (OLED) is rapidly developed.

20

[0004] The OLED emits light by injecting electrons from a cathode as an electron injection electrode and holes from an anode as a hole injection electrode into an emitting layer, combining the electrons with the holes, generating an exciton, and transforming the exciton from an excited state to a ground state. A flexible transparent substrate, for example, a plastic substrate, can be used as a base substrate where elements are formed. In addition, the emitting diode can be operated at a voltage (e.g., 10V or below) lower than a voltage required to operate other display devices and has low power consumption. Moreover, the light from the emitting diode has excellent color purity.

25

[0005] The hole from the anode and the electron are combined in an emitting material layer (EML) to generate an exciton, and the exciton is transformed from an excited state to a ground state such that the light is emitted from the organic emitting layer.

30

[0006] A fluorescent material (compound) is widely used as an emitting material of the EML. However, since only singlet exciton is involved in light emission, the fluorescent material provides low emitting efficiency (quantum efficiency).

SUMMARY

35 [0007] The present disclosure is directed to a delayed fluorescent compound and an OLED and an organic light emitting display device including the same that substantially obviate one or more of the problems associated with the limitations and disadvantages of the related conventional art.

[0008] Additional features and advantages of the present disclosure are set forth in the description which follows, and will be apparent from the description, or evident by practice of the present disclosure. The objectives and other advantages of the present disclosure are realized and attained by the features described herein as well as in the appended drawings.

40

[0009] To achieve these and other advantages in accordance with the purpose of the embodiments of the present disclosure, as described herein, there is provided a delayed fluorescent compound according to claim 1. Further embodiments are described in the dependent claims. In accordance with an aspect of the present disclosure, there is provided a delayed fluorescent compound of Formula:

45

50

55

5

10

15

20

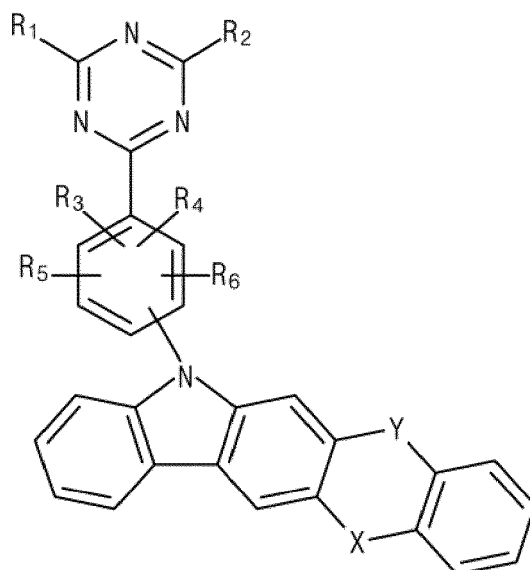

25

wherein each of R_1 to R_6 is independently selected from the group consisting of hydrogen, deuterium, halogen, cyano group, C1 to C20 alkyl group and C6 to C30 aryl group, and each of X and Y is independently selected from the group consisting of NR_7 , CR_8R_9 , O, S and $SiR_{10}R_{11}$, and wherein at least one of X and Y is NR_7 , and each of R_7 , R_8 , R_9 , R_{10} and R_{11} is independently selected from the group consisting of hydrogen, C1 to C20 alkyl group, C1 to C20 alkoxy group, C6 to C30 aryl group, C5 to C30 heteroaryl group and C1 to C20 amine group.

30

[0010] In one or more embodiments, the delayed fluorescent compound is one of the compounds 1-1, 1-2, 1-3, 1-4, 1-5, 1-6, 1-7, 1-8, 1-9, 1-10, 1-11, 1-12, 2-1, 2-2, 2-3, 2-4, 2-5, 2-6, 2-7, 2-8, 2-9, 2-10, 2-11, 2-12, 3-1, 3-2, 3-3, 3-4, 3-5, 3-6, 3-7, 3-8, 3-9, 3-10, 3-11, 3-12, 4-1, 4-2, 4-3, 4-4, 4-5, 4-6, 4-7, 4-8, 4-9, 4-10, 4-11, 4-12, 5-1, 5-2, 5-3, 5-4, 5-5, and 5-6 illustrated herein further below.

35

40

45

50

55

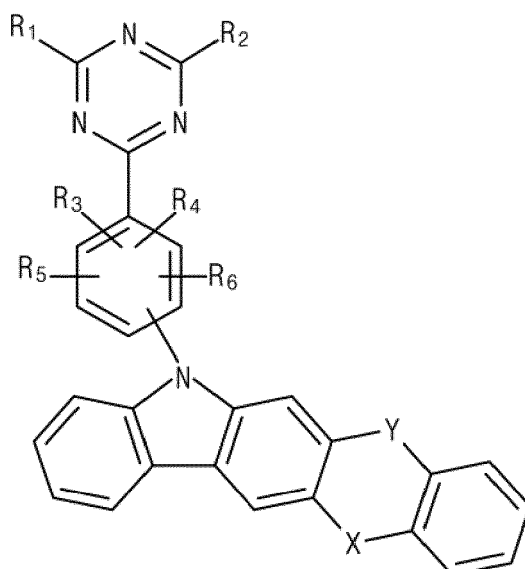

wherein each of R_1 to R_6 is independently selected from the group consisting of hydrogen, deuterium, halogen, cyano group, C1 to C20 alkyl group and C6 to C30 aryl group, and each of X and Y is independently selected from the group consisting of NR_7 , CR_8R_9 , O, S and $SiR_{10}R_{11}$, and wherein at least one of X and Y is NR_7 , and each of R_7 , R_8 , R_9 , R_{10}

and R₁₁ is independently selected from the group consisting of hydrogen, C1 to C20 alkyl group, C1 to C20 alkoxy group, C6 to C30 aryl group, C5 to C30 heteroaryl group and C1 to C20 amine group.

[0012] In one or more embodiments, the delayed fluorescent compound is used as a first dopant, and the first emitting material layer further includes a first host.

[0013] In one or more embodiments, a difference between an energy level of a highest occupied molecular orbital (HOMO) of the first host and an energy level of a HOMO of the dopant or a difference between an energy level of a lowest unoccupied molecular orbital (LUMO) of the first host and an energy level of a LUMO of the dopant is less than about 0.5 eV.

[0014] In one or more embodiments, the first host is selected from the group consisting of:

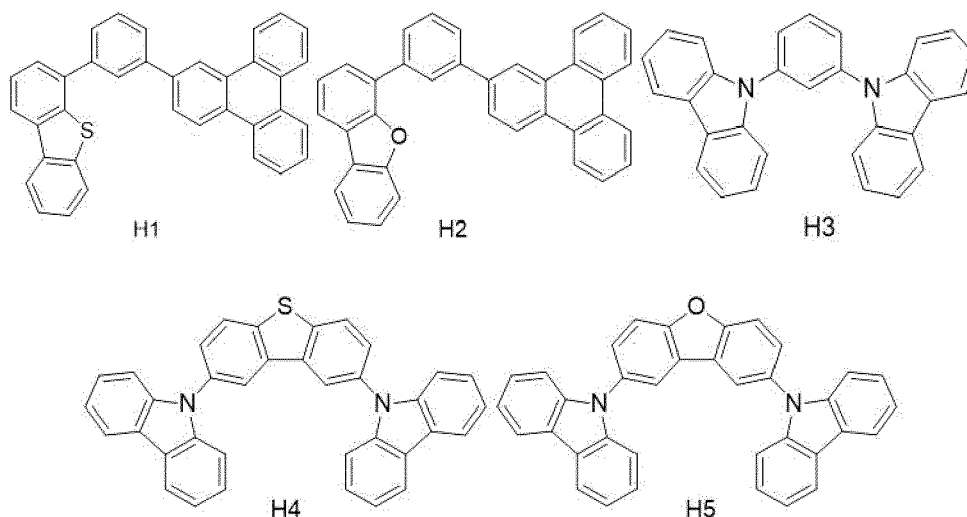

[0015] In one or more embodiments, the first emitting material layer further includes a second dopant, and an energy level of singlet state of the first dopant is greater than an energy level of singlet state of the second dopant.

[0016] In one or more embodiments, an energy level of triplet state of the first dopant is smaller than an energy level of triplet state of the first host and greater than an energy level of triplet state of the second dopant.

[0017] In one or more embodiments, the organic light emitting diode further comprises a second emitting material layer positioned between the first emitting material layer and the first electrode and including a second host and a first fluorescent dopant.

[0018] In one or more embodiments, the organic light emitting diode further comprises: an electron blocking layer between the first electrode and the second emitting material layer, wherein the second host is same as a material of the electron blocking layer.

[0019] In one or more embodiments, the organic light emitting diode further comprises: a third emitting material layer positioned between the first emitting material layer and the second electrode and including a third host and a second fluorescent dopant.

[0020] In one or more embodiments, the organic light emitting diode further comprises: a hole blocking layer between the second electrode and the third emitting material layer, wherein the third host is same as a material of the hole blocking layer.

[0021] In one or more embodiments, an energy level of singlet state of the first dopant is greater than each of an energy level of singlet state of the first fluorescent dopant and an energy level of singlet state of the second fluorescent dopant.

[0022] In one or more embodiments, an energy level of singlet state and an energy level of triplet state of the first host is greater than an energy level of singlet state and an energy level of triplet state of the first dopant, respectively, and an energy level of singlet state of the second host is greater than an energy level of singlet state of the first fluorescent dopant, and an energy level of singlet state of the third host is greater than an energy level of singlet state of the second fluorescent dopant.

[0023] In one or more embodiments, an energy level of singlet state of the first dopant is greater than an energy level of singlet state of the first fluorescent dopant.

[0024] In one or more embodiments, an energy level of singlet state and an energy level of triplet state of the first host are greater than an energy level of singlet state and an energy level of triplet state of the first dopant, respectively, and an energy level of singlet state of the second host is greater than an energy level of singlet state of the first fluorescent dopant.

[0025] In one or more embodiments, the delayed fluorescent compound is one of the compounds 1-1, 1-2, 1-3, 1-4, 1-5, 1-6, 1-7, 1-8, 1-9, 1-10, 1-11, 1-12, 2-1, 2-2, 2-3, 2-4, 2-5, 2-6, 2-7, 2-8, 2-9, 2-10, 2-11, 2-12, 3-1, 3-2, 3-3, 3-4, 3-5, 3-6, 3-7, 3-8, 3-9, 3-10, 3-11, 3-12, 4-1, 4-2, 4-3, 4-4, 4-5, 4-6, 4-7, 4-8, 4-9, 4-10, 4-11, 4-12, 5-1, 5-2, 5-3, 5-4, 5-5, and 5-6 illustrated herein further below.

[0026] Another aspect of the present disclosure is an organic light emitting display device comprising: a substrate; an organic light emitting diode on the substrate, the organic light emitting diode including: a first electrode; a second electrode facing the first electrode; and a first emitting material layer positioned between the first and second electrodes and including a delayed fluorescent compound, wherein the delayed fluorescent compound is represented by Formula:

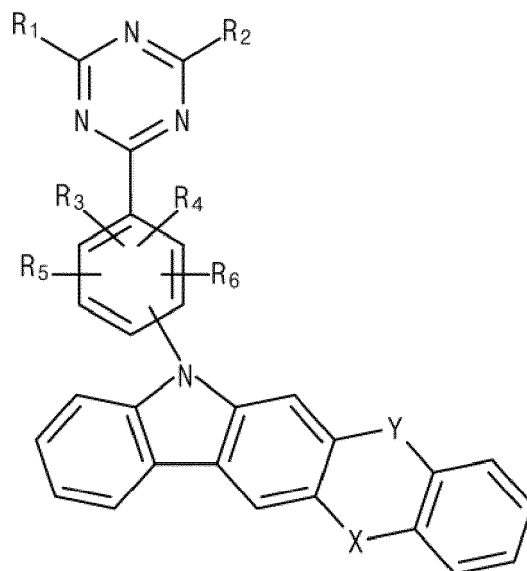

wherein each of R_1 to R_6 is independently selected from the group consisting of hydrogen, deuterium, halogen, cyano group, C1 to C20 alkyl group and C6 to C30 aryl group, and each of X and Y is independently selected from the group consisting of NR_7 , CR_8R_9 , O, S and $SiR_{10}R_{11}$, and wherein at least one of X and Y is NR_7 , and each of R_7 , R_8 , R_9 , R_{10} and R_{11} is independently selected from the group consisting of hydrogen, C1 to C20 alkyl group, C1 to C20 alkoxy group, C6 to C30 aryl group, C5 to C30 heteroaryl group and C1 to C20 amine group.

[0027] In one or more embodiments, the delayed fluorescent compound is one of the compounds 1-1, 1-2, 1-3, 1-4, 1-5, 1-6, 1-7, 1-8, 1-9, 1-10, 1-11, 1-12, 2-1, 2-2, 2-3, 2-4, 2-5, 2-6, 2-7, 2-8, 2-9, 2-10, 2-11, 2-12, 3-1, 3-2, 3-3, 3-4, 3-5, 3-6, 3-7, 3-8, 3-9, 3-10, 3-11, 3-12, 4-1, 4-2, 4-3, 4-4, 4-5, 4-6, 4-7, 4-8, 4-9, 4-10, 4-11, 4-12, 5-1, 5-2, 5-3, 5-4, 5-5, and 5-6 illustrated herein further below.

[0028] It is to be understood that both the foregoing general description and the following detailed description are exemplary and explanatory and are intended to further explain the present disclosure as claimed.

BRIEF DESCRIPTION OF THE DRAWINGS

[0029] The accompanying drawings, which are included to provide a further understanding of the present disclosure and are incorporated in and constitute a part of this specification, illustrate embodiments of the present disclosure and together with the description serve to explain the principles of the present disclosure.

FIG. 1 is a schematic cross-sectional view of an organic light emitting display device of the present disclosure.

FIG. 2 is a schematic-cross sectional view of an OLED according to a first embodiment of the present disclosure.

FIG. 3 is a view illustrating an emission mechanism of a delayed fluorescent compound according to the present disclosure.

FIG. 4 is a schematic-cross sectional view of an OLED according to a second embodiment of the present disclosure.

FIG. 5 is a schematic-cross sectional view of an OLED according to a third embodiment of the present disclosure.

DETAILED DESCRIPTION

[0030] Reference will now be made in detail to some of the examples and preferred embodiments, which are illustrated

in the accompanying drawings.

[0031] FIG. 1 is a schematic cross-sectional view of an organic light emitting display device of the present disclosure.

[0032] As shown in FIG. 1, the organic light emitting display device 100 includes a substrate 110, a TFT Tr and an OLED D connected to the TFT Tr.

[0033] The substrate 110 may be a glass substrate or a plastic substrate. For example, the substrate 110 may be a polyimide substrate.

[0034] A buffer layer 120 is formed on the substrate, and the TFT Tr is formed on the buffer layer 120. The buffer layer 120 may be omitted.

[0035] A semiconductor layer 122 is formed on the buffer layer 120. The semiconductor layer 122 may include an oxide semiconductor material or polycrystalline silicon.

[0036] When the semiconductor layer 122 includes the oxide semiconductor material, a light-shielding pattern (not shown) may be formed under the semiconductor layer 122. The light to the semiconductor layer 122 is shielded or blocked by the light-shielding pattern such that thermal degradation of the semiconductor layer 122 can be prevented. On the other hand, when the semiconductor layer 122 includes polycrystalline silicon, impurities may be doped into both sides of the semiconductor layer 122.

[0037] A gate insulating layer 124 is formed on the semiconductor layer 122. The gate insulating layer 124 may be formed of an inorganic insulating material such as silicon oxide or silicon nitride.

[0038] A gate electrode 130, which is formed of a conductive material, e.g., metal, is formed on the gate insulating layer 124 to correspond to a center of the semiconductor layer 122.

[0039] In FIG. 1, the gate insulating layer 124 is formed on an entire surface of the substrate 110. Alternatively, the gate insulating layer 124 may be patterned to have the same shape as the gate electrode 130.

[0040] An interlayer insulating layer 132, which is formed of an insulating material, is formed on the gate electrode 130. The interlayer insulating layer 132 may be formed of an inorganic insulating material, e.g., silicon oxide or silicon nitride, or an organic insulating material, e.g., benzocyclobutene or photo-acryl.

[0041] The interlayer insulating layer 132 includes first and second contact holes 134 and 136 exposing both sides of the semiconductor layer 122. The first and second contact holes 134 and 136 are positioned at both sides of the gate electrode 130 to be spaced apart from the gate electrode 130.

[0042] The first and second contact holes 134 and 136 are formed through the gate insulating layer 124. Alternatively, when the gate insulating layer 124 is patterned to have the same shape as the gate electrode 130, the first and second contact holes 134 and 136 is formed only through the interlayer insulating layer 132.

[0043] A source electrode 140 and a drain electrode 142, which are formed of a conductive material, e.g., metal, are formed on the interlayer insulating layer 132.

[0044] The source electrode 140 and the drain electrode 142 are spaced apart from each other with respect to the gate electrode 130 and respectively contact both sides of the semiconductor layer 122 through the first and second contact holes 134 and 136.

[0045] The semiconductor layer 122, the gate electrode 130, the source electrode 140 and the drain electrode 142 constitute the TFT Tr. The TFT Tr serves as a driving element.

[0046] In the TFT Tr, the gate electrode 130, the source electrode 140, and the drain electrode 142 are positioned over the semiconductor layer 122. Namely, the TFT Tr has a coplanar structure.

[0047] Alternatively, in the TFT Tr, the gate electrode may be positioned under the semiconductor layer, and the source and drain electrodes may be positioned over the semiconductor layer such that the TFT Tr may have an inverted staggered structure. In this instance, the semiconductor layer may include amorphous silicon.

[0048] Although not shown, the gate line and the data line cross each other to define the pixel region, and the switching TFT is formed to be connected to the gate and data lines. The switching TFT is connected to the TFT Tr as the driving element.

[0049] In addition, the power line, which may be formed to be parallel to and spaced apart from one of the gate and data lines, and the storage capacitor for maintaining the voltage of the gate electrode of the TFT Tr in one frame may be further formed.

[0050] A passivation layer 150, which includes a drain contact hole 152 exposing the drain electrode 142 of the TFT Tr, is formed to cover the TFT Tr.

[0051] A first electrode 160, which is connected to the drain electrode 142 of the TFT Tr through the drain contact hole 152, is separately formed in each pixel region. The first electrode 160 may be an anode and may be formed of a conductive material having a relatively high work function. For example, the first electrode 160 may be formed of a transparent conductive material such as indium-tin-oxide (ITO) or indium-zinc-oxide (IZO).

[0052] When the OLED device 100 is operated in a top-emission type, a reflection electrode or a reflection layer may be formed under the first electrode 160. For example, the reflection electrode or the reflection layer may be formed of aluminum-palladium-copper (APC) alloy.

[0053] A bank layer 166 is formed on the passivation layer 150 to cover an edge of the first electrode 160. Namely,

the bank layer 166 is positioned at a boundary of the pixel region and exposes a center of the first electrode 160 in the pixel region.

[0054] An organic emitting layer 162 is formed on the first electrode 160. The organic emitting layer 162 includes a delayed fluorescent compound of the present disclosure. As described below, the delayed fluorescent compound of the present disclosure includes an electron acceptor moiety of triazine and an electron donor moiety of indole derivative fused with a fused hetero-ring such that high emitting efficiency is provided.

[0055] When the organic light emitting display device 100 includes a red pixel region, a green pixel region and a blue pixel region, the organic emitting layer 162 may include a red emitting pattern, a green emitting pattern and a blue emitting pattern. The delayed fluorescent compound of the present disclosure is included in the organic emitting layer 162 in the green pixel region, i.e., the green emitting pattern.

[0056] The organic emitting layer 162 may have a single-layered structure of an emitting material layer including the organic emitting compound. To increase an emitting efficiency of the OLED device, the organic emitting layer 162 may have a multi-layered structure.

[0057] A second electrode 164 is formed over the substrate 110 where the organic emitting layer 162 is formed. The second electrode 164 covers an entire surface of the display area and may be formed of a conductive material having a relatively low work function to serve as a cathode. For example, the second electrode 164 may be formed of aluminum (Al), magnesium (Mg) or Al-Mg alloy.

[0058] The first electrode 160, the organic emitting layer 162 and the second electrode 164 constitute the OLED D.

[0059] An encapsulation film 170 is formed on the second electrode 164 to prevent penetration of moisture into the OLED D. The encapsulation film 170 includes a first inorganic insulating layer 172, an organic insulating layer 174 and a second inorganic insulating layer 176 sequentially stacked, but it is not limited thereto. The encapsulation film 170 may be omitted.

[0060] A polarization plate (not shown) for reducing an ambient light reflection may be disposed over the top-emission type OLED D. For example, the polarization plate may be a circular polarization plate.

[0061] In addition, a cover window (not shown) may be attached to the encapsulation film 170 or the polarization plate. In this instance, the substrate 110 and the cover window have a flexible property such that a flexible display device may be provided.

[0062] FIG. 2 is a schematic-cross sectional view of an OLED according to a first embodiment of the present disclosure.

[0063] As shown in FIG. 2, the OLED D includes the first and second electrodes 160 and 164, which face each other, and the organic emitting layer 162 therebetween. The organic emitting layer 162 includes an emitting material layer (EML) 240 between the first and second electrodes 160 and 164, a hole transporting layer (HTL) 220 between the first electrode 160 and the EML 240 and an electron transporting layer (ETL) 260 between the second electrode 164 and the EML 240.

[0064] In addition, the organic emitting layer 162 may further include a hole injection layer (HIL) 210 between the first electrode 160 and the HTL 220 and an electron injection layer (EIL) 270 between the second electrode 164 and the ETL 260.

[0065] Moreover, the organic emitting layer 162 may further include an electron blocking layer (EBL) 230 between the HTL 220 and the EML 240 and a hole blocking layer (HBL) 250 between the EML 240 and the ETL 260.

[0066] The organic emitting layer 162, preferably the EML 240 includes the delayed fluorescent compound of the present disclosure. The delayed fluorescent compound may be used as a dopant.

[0067] The delayed fluorescent compound of the present disclosure includes an electron acceptor moiety of triazine and an electron donor moiety of indole derivative fused with a fused hetero-ring. The delayed fluorescent compound may be represented by Formula 1.

[Formula 1]

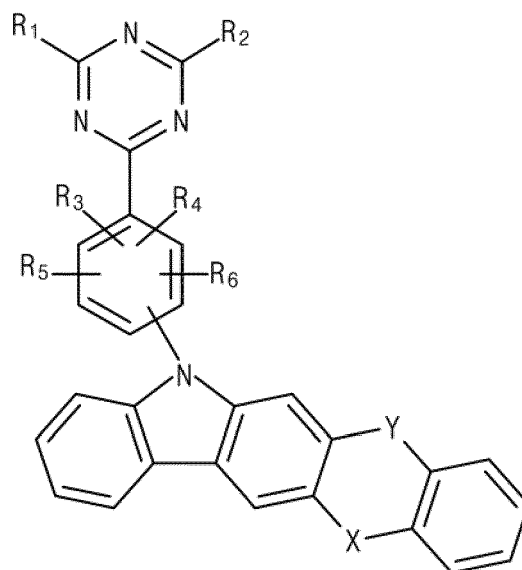

In Formula 1, each of R₁ to R₆ is independently selected from the group consisting of hydrogen, deuterium, halogen, cyano group, C1 to C20 alkyl group and C6 to C30 aryl group. Each of X and Y is independently selected from the group consisting of NR₇, CR₈R₉, O, S and SiR₁₀R₁₁, and at least one of X and Y is NR₇. Each of R₇, R₈, R₉, R₁₀ and R₁₁ is independently selected from the group consisting of hydrogen, C1 to C20 alkyl group, C1 to C20 alkoxy group, C6 to C30 aryl group, C5 to C30 heteroaryl group and C1 to C20 amine group.

[0068] For example, each of R₁ and R₂ may be independently selected from C6 to C30 aryl group, and at least one of R₃ to R₆ may be cyano group. R₇ may be selected from C6 to C30 aryl, and each of R₈ to R₁₁ may be independently selected from C1 to C20 alkyl group.

[0069] In the delayed fluorescent compound, the electron donor moiety and the electron acceptor moiety are bonded (combined or linked) in the molecule such that an overlap between the highest occupied molecular orbital (HOMO) and the lowest unoccupied molecular orbital (LUMO) is reduced. As a result, a charge transfer complex is generated, and the emitting efficiency of the delayed fluorescent compound is improved. Namely, in the delayed fluorescent compound, the triplet exciton is used for emission such that the emitting efficiency is improved.

[0070] In addition, in the delayed fluorescent compound of the present disclosure, since the electron donor moiety and the electron acceptor moiety are bonded to a phenylene linker at a para-position and at least one cyano group is bonded to the phenylene linker, the delayed fluorescent compound provides green light with high efficiency.

[0071] Referring to FIG. 3, which is a view illustrating an emission mechanism of a delayed fluorescent compound according to the present disclosure, in the delayed fluorescent compound of the present disclosure, the triplet excitons as well as the singlet excitons are engaged in the emission such that the emitting efficiency is improved.

[0072] Namely, the triplet exciton is activated by a field or heat, and the triplet exciton and the singlet exciton are transferred into an intermediated state "I₁" and transited into a ground state "S₀" to emit the light. In other words, the singlet state "S₁" and the triplet state "T₁" are transited into the intermediated state "I₁" (S₁→ I₁←T₁), and the singlet exciton and the triplet exciton in the intermediated state "I₁" are involved in the light emission such that the emitting efficiency is improved.

[0073] In the related art fluorescence compound, since the HOMO and the LUMO are dispersed throughout an entirety of the molecule, the interconversion of the HOMO and the LUMO is impossible. (Selection Rule.)

[0074] However, in the delayed fluorescent compound, since the overlap between the HOMO and the LUMO in the molecule is relatively small, the interaction between the HOMO and the LUMO is small. Accordingly, changes of the spin state of one electron do not affect other electrons, and a new charge transfer band, which does not comply with the Selection Rule, is generated.

[0075] Moreover, since the electron donor moiety and the electron acceptor moiety is spatially spaced apart from each other in the molecule, the dipole moment is generated in a polarized state. In the polarized state dipole moment, the interaction between the HOMO and the LUMO is further reduced such that the emission mechanism does not comply with the Selection Rule. Accordingly, in the delayed fluorescent compound, the transition from the triplet state "T₁" and the singlet state "S₁" into the intermediated state "I₁" can be generated such that the triplet exciton can be involved in the light emission.

[0076] When the OLED is driven, the intersystem transition (intersystem crossing) from 25% singlet state "S₁" excitons and 75% triplet state "T₁" excitons to the intermediated state "I₁" is generated, and the singlet and triplet excitons in the

intermediated state "I₁" are transited into the ground state to emit the light. As a result, the delayed fluorescent compound has the theoretic quantum efficiency of 100%.

[0077] For example, the delayed fluorescent compound of Formula 1 may be selected from materials in Formula 2.

5

[Formula 2]

10

15

20

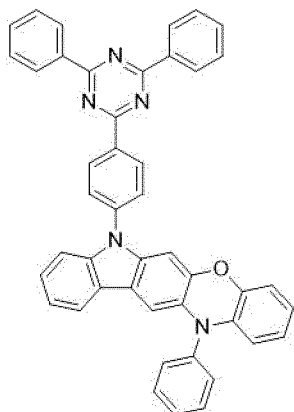

compound 1-1

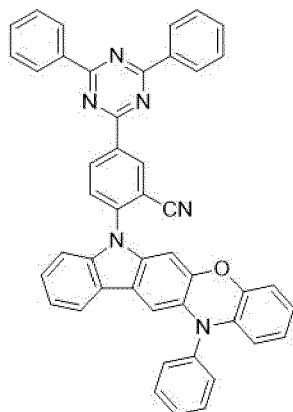

compound 1-2

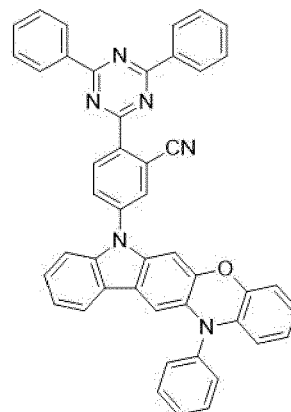

compound 1-3

25

30

35

40

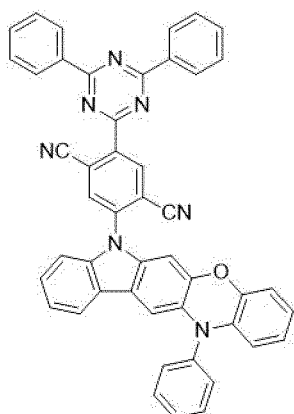

compound 1-4

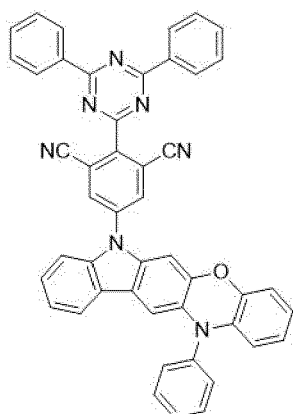

compound 1-5

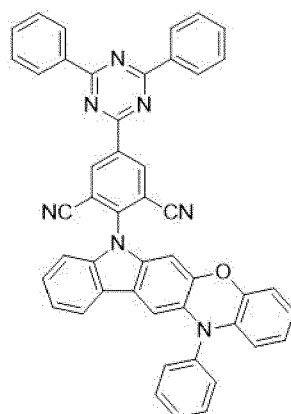

compound 1-6

45

50

55

5

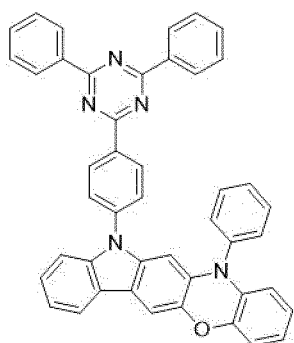

compound 1-7

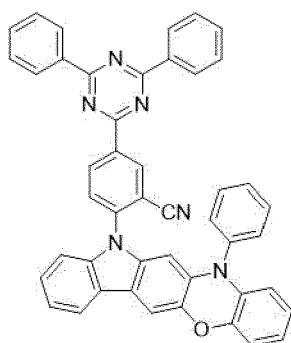

compound 1-8

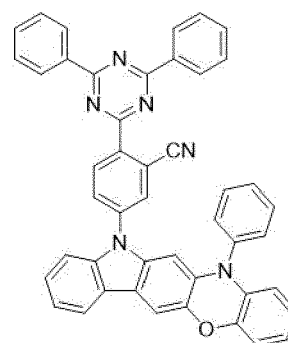

compound 1-9

15

20

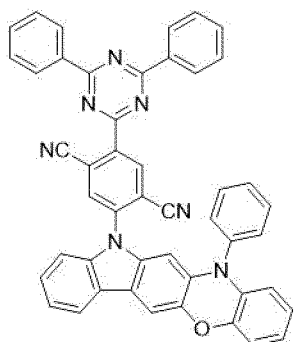

compound 1-10

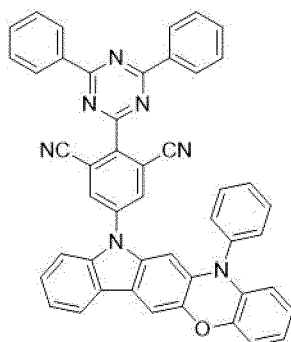

compound 1-11

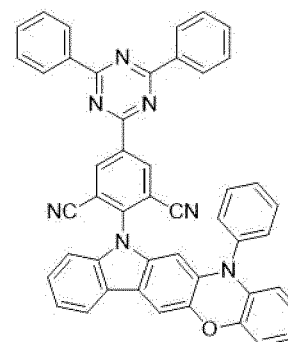

compound 1-12

25

30

35

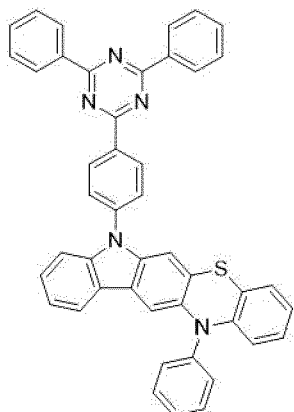

compound 2-1

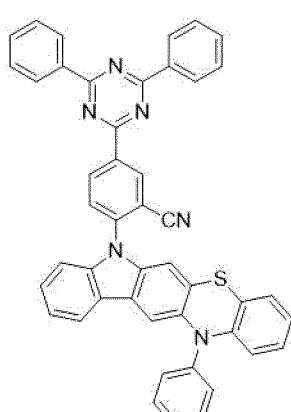

compound 2-2

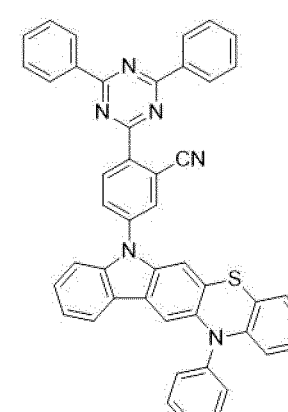

compound 2-3

40

45

50

55

5

10

15

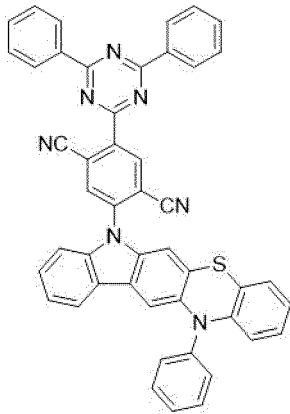

compound 2-4

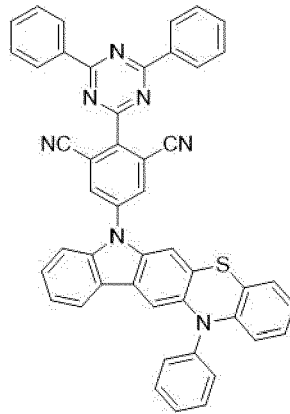

compound 2-5

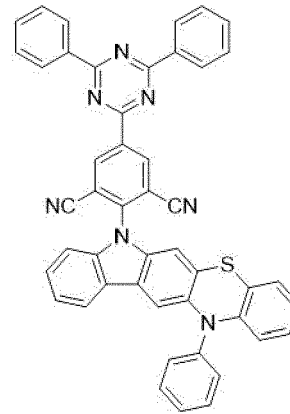

compound 2-6

20

25

30

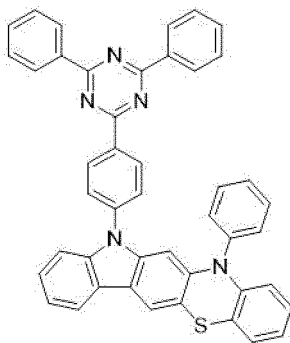

compound 2-7

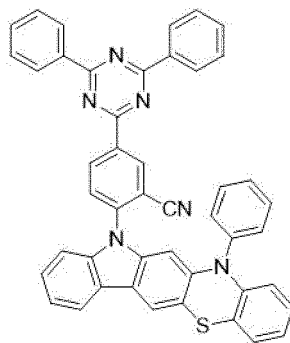

compound 2-8

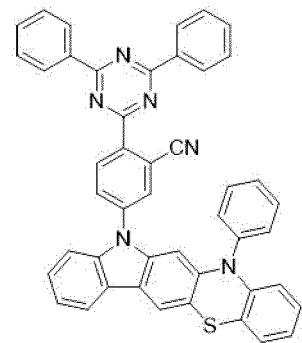

compound 2-9

35

40

45

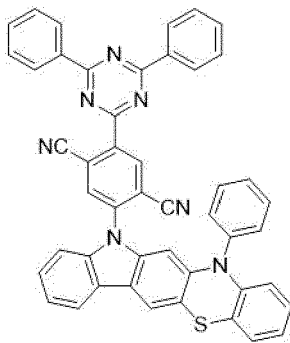

compound 2-10

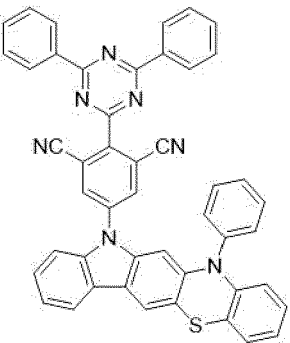

compound 2-11

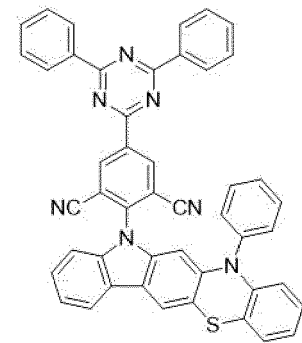

compound 2-12

50

55

5

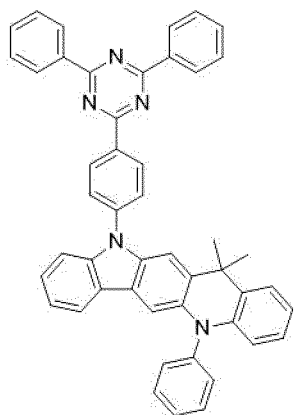

compound 3-1

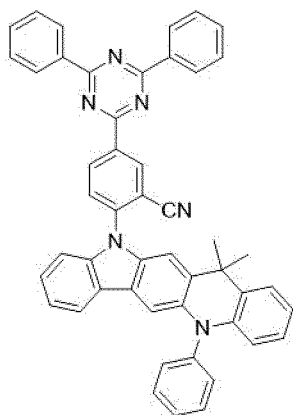

compound 3-2

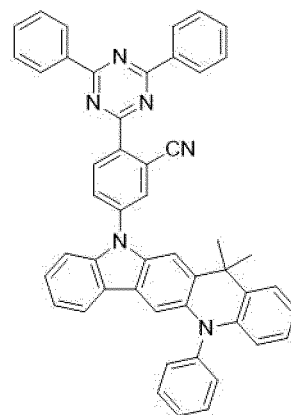

compound 3-3

10

15

20

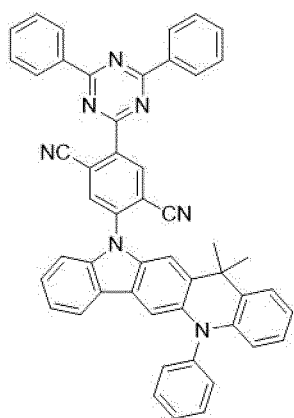

compound 3-4

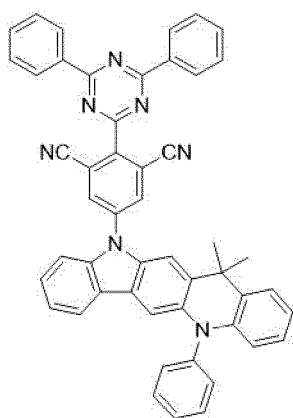

compound 3-5

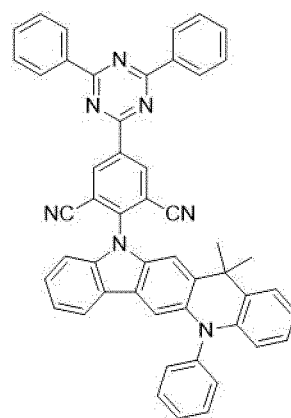

compound 3-6

25

30

35

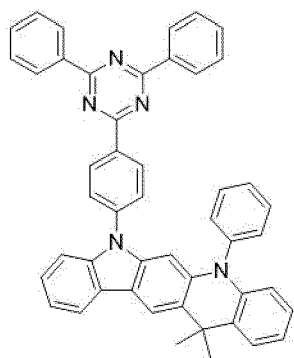

compound 3-7

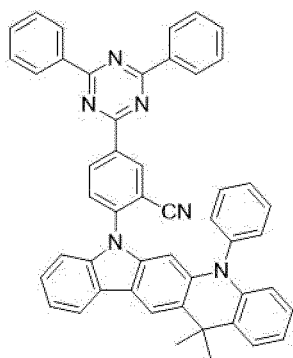

compound 3-8

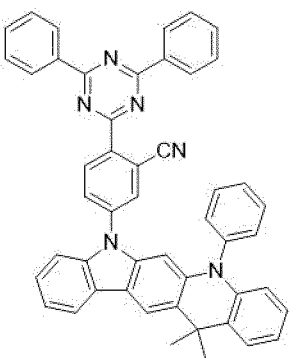

compound 3-9

40

45

50

55

5

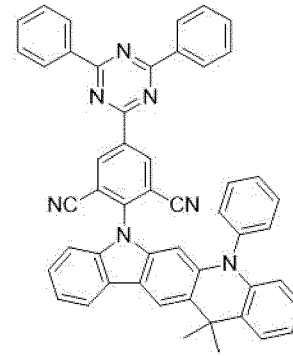
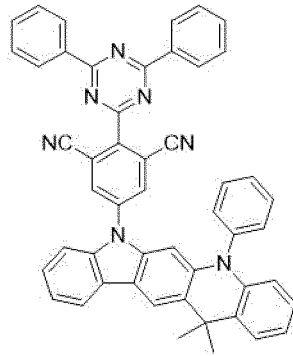
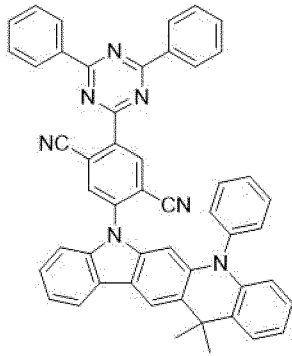

10

15

compound 3-10

compound 3-11

compound 3-12

20

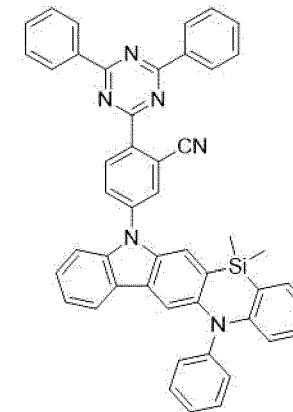
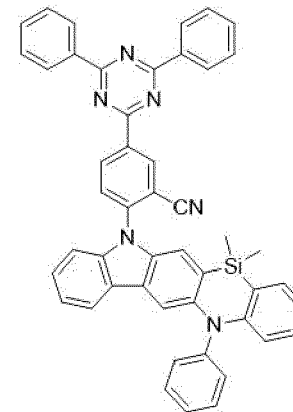
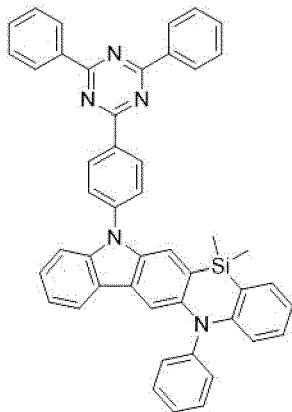

25

30

compound 4-1

compound 4-2

compound 4-3

35

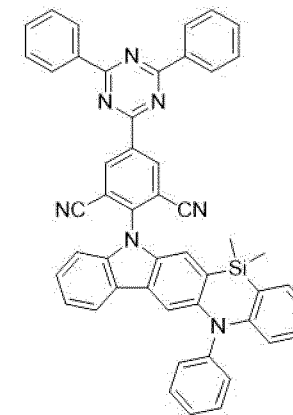
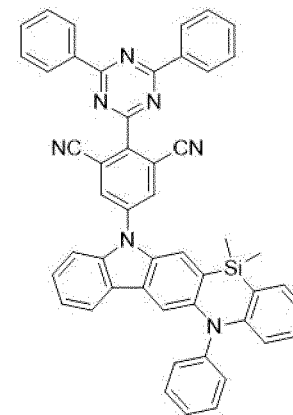
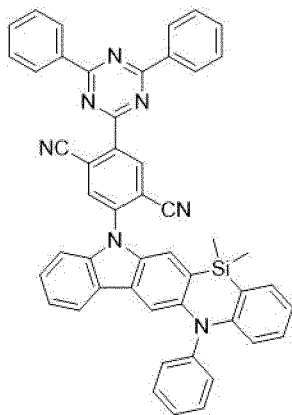

40

45

50

compound 4-4

compound 4-5

compound 4-6

55

5

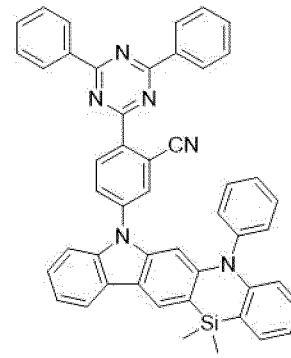
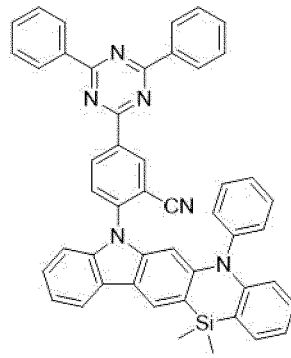
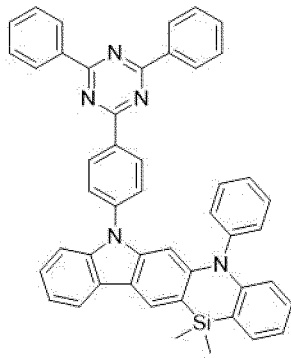

10

compound 4-7

compound 4-8

compound 4-9

15

20

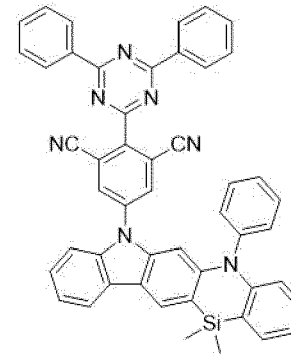
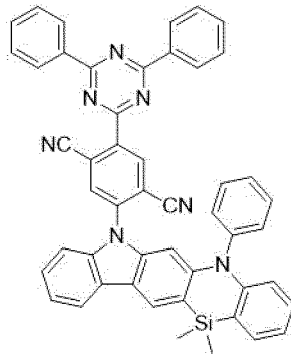
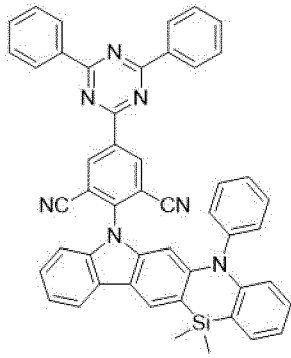

25

30

compound 4-10

compound 4-11

compound 4-12

35

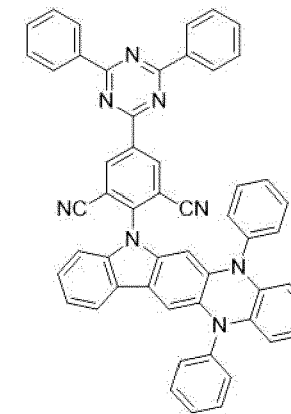
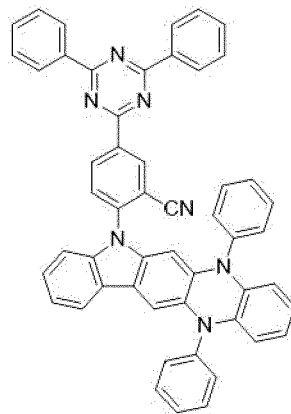
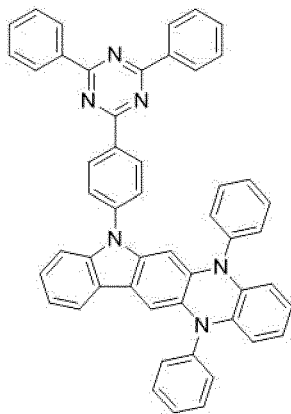

40

45

compound 5-1

compound 5-2

compound 5-3

50

55

5

10

15

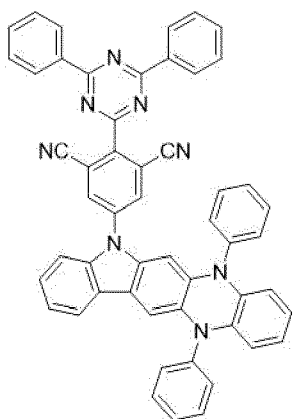

compound 5-4

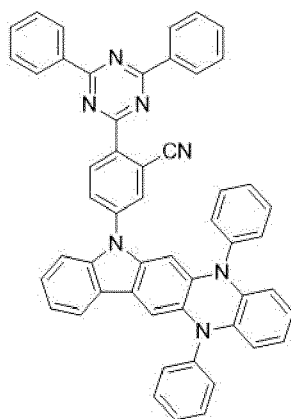

compound 5-5

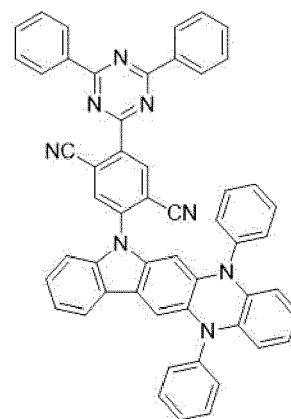

compound 5-6

[Synthesis of delayed fluorescent compounds]

20

1. Synthesis of compound 1-1

(1) compound A-2

25

[0078]

[Reaction Formula 1-1]

30

35

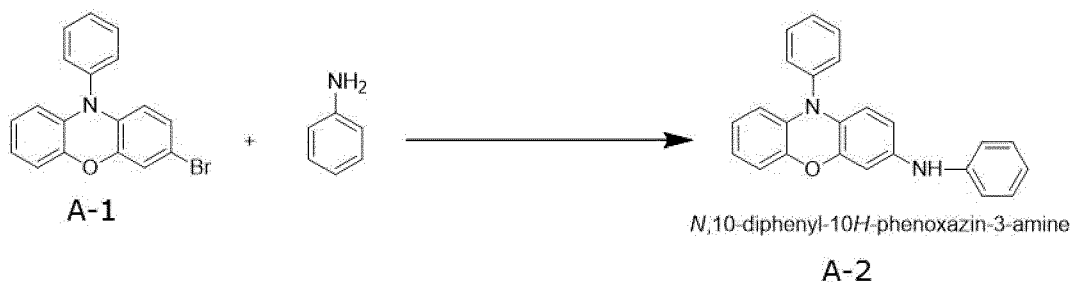

40

[0079] In the two-neck flask (1000 ml), the compound A-1 (30.0g, 88.70mmol), aniline (9.09g, 97.58mmol), Pd₂(dba)₃ (0.81g, 0.89mmol), tri-*tert*-butylphosphine (0.18g, 0.89mmol), and sodium-*tert*-butoxide (12.79g, 133.06mmol) were suspended in toluene (500ml), and the mixture was refluxed and stirred for 12 hrs. After completion of reaction, the mixture was extracted with dichloromethane and distilled water, and the organic layer was removed by the reduced-pressure distillation. The resultant was silica-gel-columned such that the compound A-2 is obtained. (25.0g, yield: 80.43%)

45

(2) compound A-3

[0080]

50

[Reaction Formula 1-2]

55

5

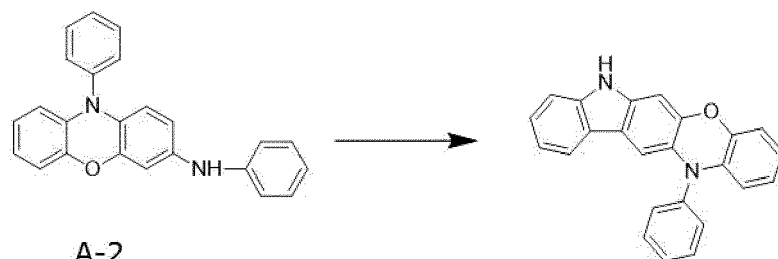

10

12-phenyl-5,12-dihydroindolo[3,2-*b*]phenoxazine

A-3

15

[0081] In the two-neck flask (500 ml), the compound A-2 (20.0g, 57.14mmol) and Pd(OAc)₂ (0.64g, 2.86mmol) were suspended in acetic acid (200ml), and the mixture was refluxed and stirred for 12 hrs. After completion of reaction, the mixture was extracted with dichloromethane and distilled water, and the organic layer was removed by the reduced-pressure distillation. The resultant was silica-gel-columned such that the compound A-3 is obtained. (15.10g, yield: 75.85%)

20

(3) compound 1-1

[0082]

25

[Reaction Formula 1-3]

30

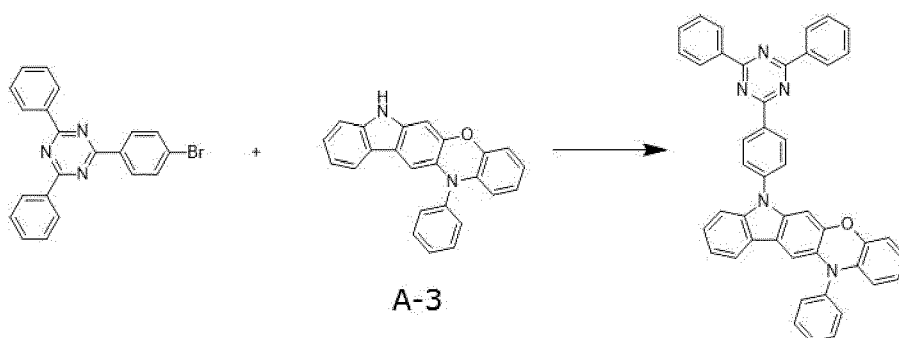

35

A-3

5-(4-(4,6-diphenyl-1,3,5-triazin-2-yl)phenyl)-12-phenyl-5,12-dihydroindolo[3,2-*b*]phenoxazine

40

[0083] In the two-neck flask (250 ml), the compound A-3 (5.0g, 14.35mmol), 2-(4-bromophenyl)-4,6-diphenyl-1,3,5-triazine (6.69g, 17.22mmol), Pd₂(dba)₃ (0.39g, 0.43mmol), tri-*tert*-butylphosphine (0.09g, 0.43mmol), and sodium-*tert*-butoxide (4.14g, 43.05mmol) were suspended in toluene (200ml), and the mixture was refluxed and stirred for 12 hrs. After completion of reaction, the mixture was extracted with dichloromethane and distilled water, and the organic layer was removed by the reduced-pressure distillation. The resultant was silica-gel-columned such that the compound 1-1 is obtained. (4.00g, yield: 42.50%)

45

2. Synthesis of compound 1-2

50

(1) compound B-2

[0084]

55

[Reaction Formula 2-1]

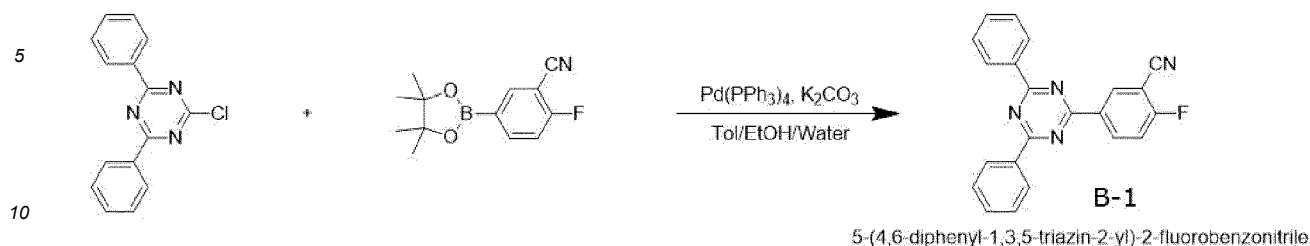

15 **[0085]** In the two-neck flask (500 ml), 2-chloro-4,6-diphenyl-1,3,5-triazine (2.00g, 7.47mmol), 2-fluoro-5-(4,4,5,5-tetramethyl-1,3,2-dioxaborolan-2-yl)benzonitrile (2.77g, 11.21mmol), K_2CO_3 (5.16g, 37.35mmol), and $Pd(PPh_3)_4$ were dissolved in the solvent of toluene, ethanol (EtOH) and water (volume ratio=3:1:1, 250ml), and the mixture was refluxed and stirred for 12 hrs. After completion of reaction, the mixture was columned using methylene chloride (MC) and hexane (volume ratio=3:7) such that the compound B-1 is obtained. (2.10g, yield: 79.78%)

20 (2) compound 1-2

[0086]

[Reaction Formula 2-2]

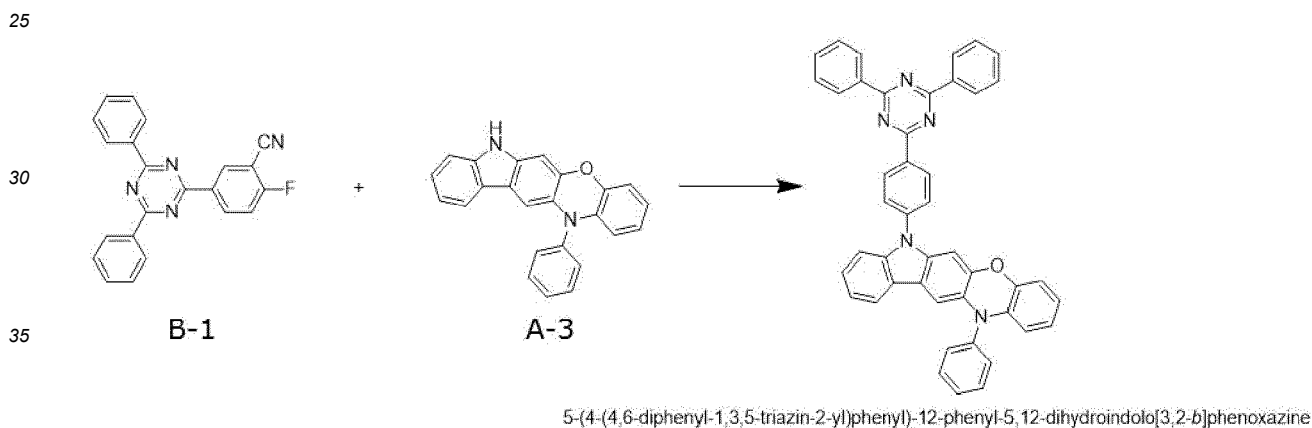

40 **[0087]** In the two-neck flask (250 ml), the compound A-3 (2.18g, 6.24mmol) was dissolved in dimethylformamide (DMF, 50ml), and NaH (55%, 0.5g, 11.35mmol) was added. After the mixture was stirred for 30 minutes, the compound B-1 (2.0g, 5.68mmol) was added. The mixture was refluxed and stirred for 12 hrs. After completion of reaction, the mixture was extracted with dichloromethane and distilled water, and the organic layer was removed by the reduced-pressure distillation. The resultant was silica-gel-columned such that the compound 1-2 is obtained. (2.9g, yield: 73.75%)

45 3. Synthesis of compound 1-6

[0088]

50

55

[Reaction Formula 3]

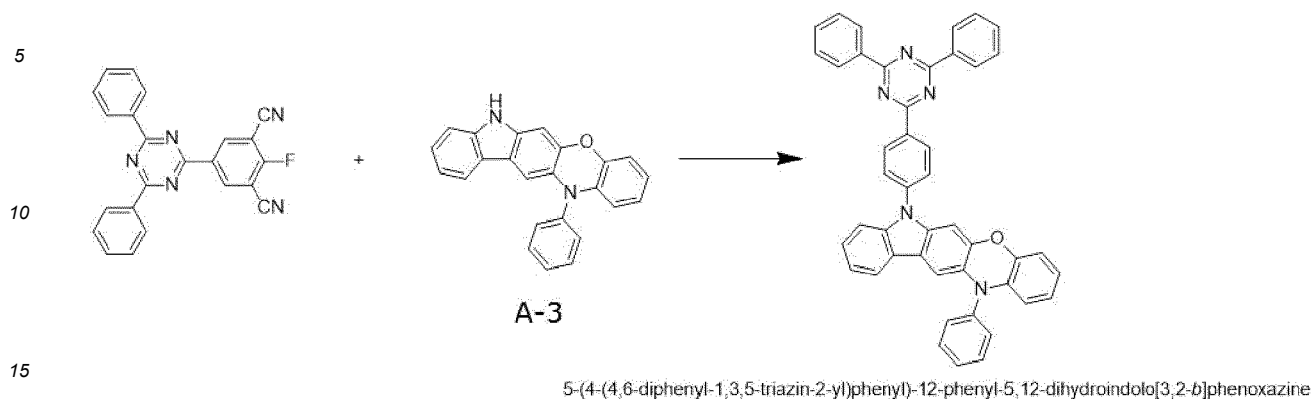

20

[0089] In the two-neck flask (250 ml), the compound A-3 (2.03g, 5.83mmol) was dissolved in DMF (50ml), and NaH (55%, 0.46g, 10.60mmol) was added. After the mixture was stirred for 30 minutes, the triazine compound (2.0g, 5.30mmol) was added. The mixture was refluxed and stirred for 12 hrs. After completion of reaction, the mixture was extracted with dichloromethane and distilled water, and the organic layer was removed by the reduced-pressure distillation. The resultant was silica-gel-columned such that the compound 1-6 is obtained. (2.5g, yield: 68.09%)

4. Synthesis of compound 2-2

25

[0090]

[Reaction Formula 4]

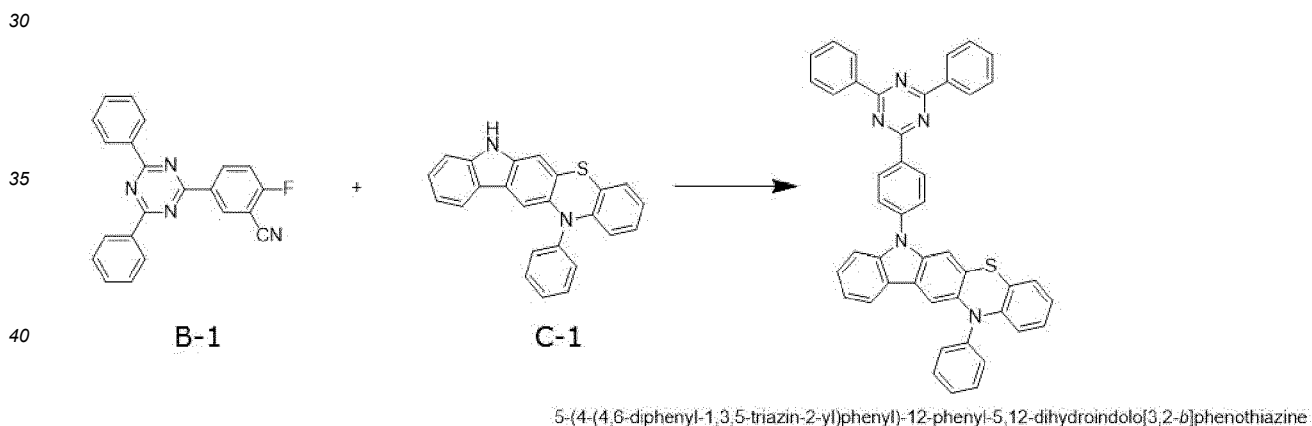

45

[0091] In the two-neck flask (250 ml), the compound C-1 (2.28g, 6.24mmol) was dissolved in DMF (50ml), and NaH (55%, 0.50g, 11.35mmol) was added. After the mixture was stirred for 30 minutes, the compound B-1 (2.0g, 5.68mmol) was added. The mixture was refluxed and stirred for 12 hrs. After completion of reaction, the mixture was extracted with dichloromethane and distilled water, and the organic layer was removed by the reduced-pressure distillation. The resultant was silica-gel-columned such that the compound 2-2 is obtained. (2.4g, yield: 62.94%)

5. Synthesis of compound 3-2

50

[0092]

55

[Reaction Formula 5]

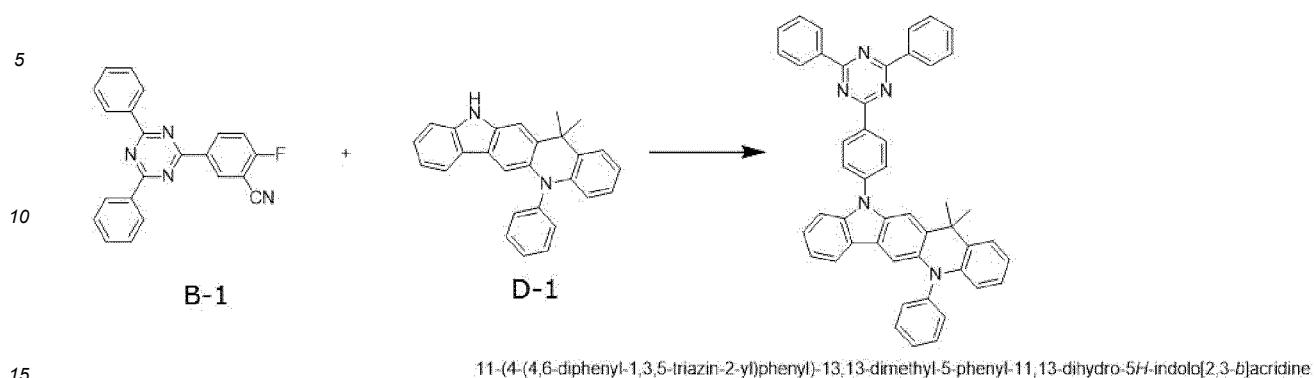

[0093] In the two-neck flask (250 ml), the compound D-1 (2.34g, 6.24mmol) was dissolved in DMF (50ml), and NaH (55%, 0.50g, 11.35mmol) was added. After the mixture was stirred for 30 minutes, the compound B-1 (2.0g, 5.68mmol) was added. The mixture was refluxed and stirred for 12 hrs. After completion of reaction, the mixture was extracted with dichloromethane and distilled water, and the organic layer was removed by the reduced-pressure distillation. The resultant was silica-gel-columned such that the compound 3-2 is obtained. (2.8g, yield: 72.35%)

[0094] Referring to FIG. 2, the EML 240 may further include a host. In the EML 240, the host may have a percentage by weight of approximately 50 to 99%, and the dopant, i.e., the delayed fluorescent compound of the present disclosure, may have a percentage by weight of about 1 to 50%. For example, the host may have a percentage by weight of approximately 60 to 80%, and the dopant may have a percentage by weight of about 20 to 40%.

[0095] A difference between an energy level of the HOMO of the host "HOMO_{Host}" and an energy level of the HOMO of the dopant "HOMO_{Dopant}" or a difference between an energy level of the LUMO of the host "LUMO_{Host}" and an energy level of the LUMO of the dopant "LUMO_{Dopant}" is less than about 0.5 eV. In this instance, the charge transfer efficiency from the host to the dopant may be improved.

[0096] The energy level of triplet state of the dopant is smaller than the energy level of triplet state of the host, and a difference between the energy level of singlet state of the dopant and the energy level of triplet state of the dopant is equal to or less than 0.3eV. ($\Delta E_{ST} \leq 0.3\text{eV}$.) As the difference " ΔE_{ST} " is smaller, the emitting efficiency is higher. In addition, even if the difference " ΔE_{ST} " between the energy level of singlet state of the dopant and the energy level of triplet state of the dopant is about 0.3eV, which is relatively large, the excitons in the singlet state (S_1) and the excitons in the triplet state (T_1) can be transited into the intermediate state.

[0097] For example, the host may be selected from materials in Formula 3.

[Formula 3]

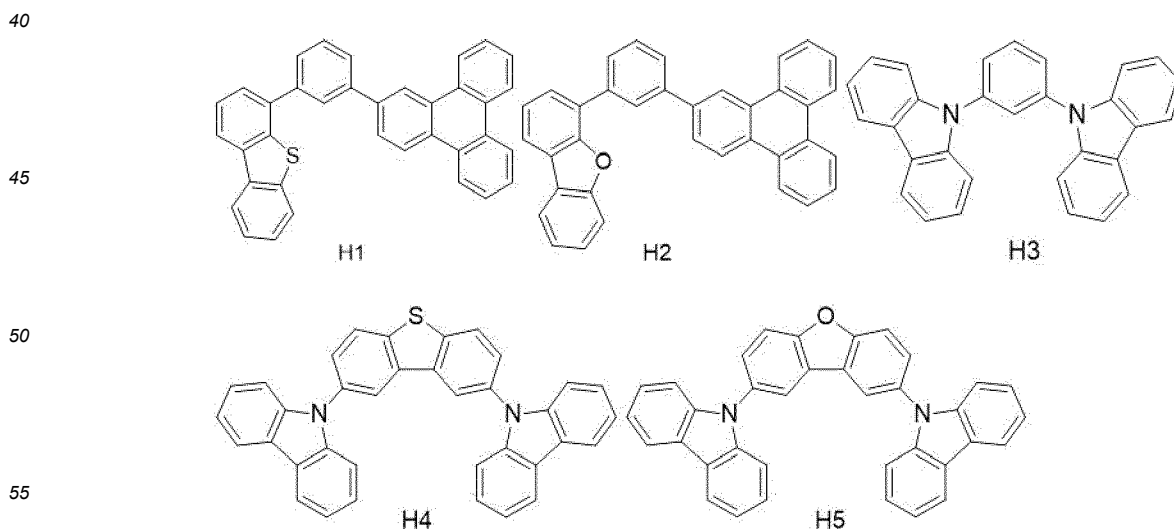

[0098] The EML 240 may include the delayed fluorescent compound of the present disclosure as a first dopant and

a host with a second dopant. In the EML 240, a summation of percentage by weight of the first and second dopants may be about 1 to 50. For example, the second dopant may be a fluorescent material (compound).

[0099] Since the EML 240 includes the host and the first and second dopant, the emitting efficiency may be improved by the first dopant and the color purity may be improved by the second dopant. Namely, after the triplet exciton in the first dopant, which has high emitting efficiency, is converted into the singlet exciton in the first dopant, the singlet exciton in the first dopant is transferred into the second dopant, which has narrow full width at a half maximum (FWHM) such that the light emission is provided from the second dopant. As a result, the emitting efficiency and the color purity of the OLED D are improved.

[0100] An energy level of singlet state of the first dopant (the delayed fluorescent compound) is greater than that of the second dopant (the fluorescent compound). An energy level of triplet state of the first dopant is smaller than that of the host and greater than that of the second dopant.

[0101] As mentioned above, in the delayed fluorescent compound of the present disclosure, the triplet exciton is activated by an external force, e.g., an electric field generated in the operation of the OLED, such that the singlet exciton and the triplet exciton are involved in the light emission. Accordingly, the delayed fluorescent compound provides high emitting efficiency.

[0102] As a result, in the OLED D and the organic light emitting display device 100 including the delayed fluorescent compound, the emitting efficiency is improved, and high quality image is provided.

[OLED]

[0103] Following layers are sequentially deposited on an ITO layer (anode).

[0104] (a) HIL (compound of Formula 4 (HATCN), 7nm), (b) HTL (compound of Formula 5 (NPB), 55nm), (c) EBL (compound of Formula 6 (m-CBP), 10nm), (d) EML (35nm), (e) HBL (compound of Formula 7 (B3PYMPM), 10nm), (f) ETL (compound of Formula 8 (TPBi), 20nm), (g) EIL (LiF), and (h) Cathode (Al)

[Formula 4]

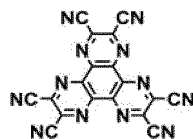

[Formula 5]

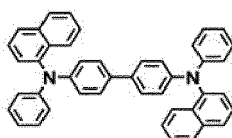

[Formula 6]

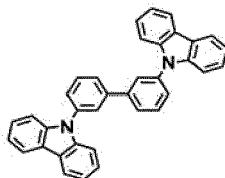

[Formula 7]

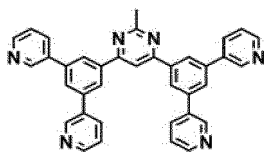

10 [Formula 8]

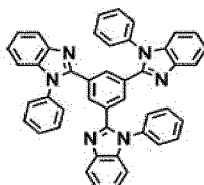

20 (1) Reference Example 1

[0105] In the EML, the compound H-1 of Formula 3 (70wt%) is used as the host, and the compound of Formula 9 (30wt%) is used as the delayed fluorescent dopant.

25 (2) Reference Example 2

[0106] In the EML, the compound H-1 of Formula 3 (70wt%) is used as the host, and the compound of Formula 10 (30wt%) is used as the delayed fluorescent dopant.

30 (3) Example 1

[0107] In the EML, the compound H-1 of Formula 3 (70wt%) is used as the host, and the compound 1-1 of Formula 2 (30wt%) is used as the delayed fluorescent dopant.

35 (4) Example 2

[0108] In the EML, the compound H-1 of Formula 3 (70wt%) is used as the host, and the compound 1-2 of Formula 2 (30wt%) is used as the delayed fluorescent dopant.

40 (5) Example 3

[0109] In the EML, the compound H-1 of Formula 3 (70wt%) is used as the host, and the compound 1-6 of Formula 2 (30wt%) is used as the delayed fluorescent dopant.

45 (6) Example 4

[0110] In the EML, the compound H-1 of Formula 3 (70wt%) is used as the host, and the compound 2-2 of Formula 2 (30wt%) is used as the delayed fluorescent dopant.

50 (7) Example 5

[0111] In the EML, the compound H-1 of Formula 3 (70wt%) is used as the host, and the compound 3-2 of Formula 2 (30wt%) is used as the delayed fluorescent dopant.

55

[Formula 9]

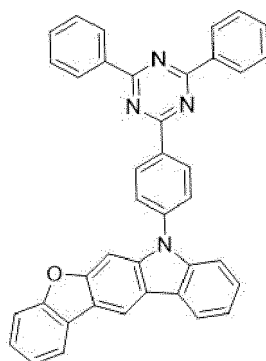

[Formula 10]

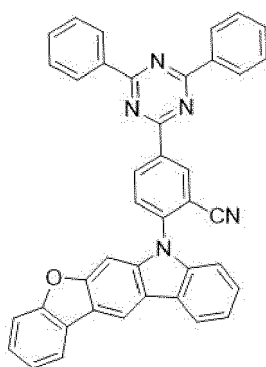

35

[0112] The properties, i.e., voltage (V), current efficiency (cd/A), power efficiency (lm/W), external quantum efficiency (EQE), maximum EL ($EL_{\lambda, \max}$), and CIE color coordinate, of the OLED of Reference Examples 1 and 2 and Examples 1 to 5 are measured and listed in Table 1.

Table 1

40

45

| | V | cd/A | lm/W | EQE (%) | $EL_{\lambda, \max}$ (nm) | CIE |
|------|------|-------|-------|---------|---------------------------|----------------|
| Ref1 | 4.71 | 6.2 | 4.2 | 3.09 | 476, | (0,187, 0.291) |
| Ref2 | 4.17 | 10.1 | 7.62 | 3.89 | 500 | (0.228, 0.430) |
| Ex1 | 3.97 | 38.04 | 30.10 | 9.6 | 536 | (0,338, 0.571) |
| Ex2 | 4.00 | 56.2 | 44.0 | 17,6 | 546 | (0.419, 0.554) |
| Ex3 | 3,56 | 46.85 | 41.33 | 13.75 | 544 | (0.399, 0.563) |
| Ex4 | 4.48 | 57.84 | 40.56 | 16.56 | 540 | (0.369, 0.563) |
| Ex5 | 3.84 | 50.79 | 41.57 | 15.93 | 568 | (0.489, 0.504) |

50

[0113] As shown in Table 1, in comparison to the OLED in Reference Examples 1 and 2, the OLED of Examples 1 to 5 including the delayed fluorescent compound of the present disclosure has high emitting efficiency.

[0114] Particularly, when the phenylene linker is substituted by cyano group, the emitting efficiency is significantly improved.

55

[0115] FIG. 4 is a schematic-cross sectional view of an OLED according to a second embodiment of the present disclosure.

[0116] As shown in FIG. 4, an OLED D includes the first and second electrodes 160 and 164, which face each other, and the organic emitting layer 162 therebetween. The organic emitting layer 162 includes an EML 340, which includes

first and second layers 342 and 344 and is positioned between the first and second electrodes 160 and 164, an HTL 320 between the first electrode 160 and the EML 340 and an ETL 360 between the second electrode 164 and the EML 340.

[0117] In addition, the organic emitting layer 162 may further include a HIL 310 between the first electrode 160 and the HTL 320 and an EIL 370 between the second electrode 164 and the ETL 360.

5 [0118] Moreover, the organic emitting layer 162 may further include an EBL 330 between the HTL 320 and the EML 340 and a HBL 350 between the EML 340 and the ETL 360.

[0119] For example, in the EML 340, one of the first layer 342 (e.g., a first emitting material layer) and the second layer 344 (e.g., a second emitting material layer) may include the delayed fluorescent compound of the present disclosure as a first dopant (a delayed fluorescent dopant). The other one of the first and second layers 342 and 344 may include a fluorescent compound as a second dopant (a fluorescent dopant). The energy level of the singlet state of the delayed fluorescent compound is higher than that of the fluorescent compound.

10 [0120] The OLED D, where the first layer 342 includes the delayed fluorescent compound, and the second layer 344 includes the fluorescent compound, will be explained.

[0121] In the OLED D, the energy level of singlet state and the energy level of triplet state of the delayed fluorescent compound are transferred into the fluorescent compound such that the light emission is provided from the fluorescent compound. As a result, the quantum efficiency of the OLED D is increased, and the FWHM of the OLED D is narrowed.

15 [0122] The delayed fluorescent compound having a delayed fluorescence property has high quantum efficiency. However, since the light emitted from the delayed fluorescent compound has wide FWHM, the light from the delayed fluorescent compound has poor color purity. On the other hand, the fluorescence compound has narrow FWHM and high color purity. However, since the energy level of triplet state of the fluorescence compound is not involved in the emission, the fluorescence compound has low quantum efficiency.

20 [0123] Since the EML 340 of the OLED D in the present disclosure includes the first layer 342, which includes the delayed fluorescent compound as the dopant, and the second layer 344, which includes the fluorescence compound as the dopant, the OLED D has advantages in both the emitting efficiency and the color purity.

25 [0124] The energy level of triplet state of the delayed fluorescent compound is converted into the energy level of singlet state of the delayed fluorescent compound by the reverse intersystem crossing (RISC) effect, and the energy level of singlet state of the delayed fluorescent compound is transferred into the energy level of singlet state of the fluorescence compound. Namely, the difference between the energy level of triplet state of the delayed fluorescent compound and the energy level of singlet state of the delayed fluorescent compound is not greater than 0.3eV such that the energy level of triplet state of the delayed fluorescent compound is converted into the energy level of singlet state of the delayed fluorescent compound by the RISC effect.

30 [0125] As a result, the delayed fluorescent compound has an energy transfer function, and the first layer 342 including the delayed fluorescent compound is not engaged in the light emission. The light emission is generated in the second layer 344 including the fluorescence compound.

35 [0126] The energy level of triplet state of the delayed fluorescent compound is converted into the energy level of singlet state of the delayed fluorescent compound by the RISC effect. In addition, since the energy level of singlet state of the delayed fluorescent compound is higher than that of the fluorescence compound, the energy level of singlet state of the delayed fluorescent compound is transferred into the energy level of singlet state of the fluorescence compound. As a result, the fluorescence compound emits the light using the energy level of singlet state and the energy level of triplet state such that the quantum efficiency (emitting efficiency) of the OLED D is improved.

40 [0127] In other words, the OLED D and the organic light emitting display device 100 (of FIG. 1) including the OLED D has advantages in both the emitting efficiency (quantum efficiency) and the color purity (FWHM).

[0128] The first and second layers 342 and 344 may further includes first and second hosts, respectively. The first and second hosts are same material or different materials. Each of the first and second hosts may be selected from the materials of Formula 3. Alternatively, the first host may be selected from the materials of Formula 3, while the second host may be common host compound.

45 [0129] The first and second hosts may have a percentage by weight being larger than the delayed fluorescent compound and the fluorescence compound, respectively. In addition, the percentage by weight of the delayed fluorescent compound in the first layer 342 may be greater than that of the fluorescence compound in the second layer 344. As a result, the energy transfer from the delayed fluorescent compound into the fluorescence compound is sufficiently generated.

50 [0130] The energy level of singlet state of the first host is greater than that of the delayed fluorescent compound (first dopant), and the energy level of triplet state of the first host is greater than that of the delayed fluorescent compound. In addition, the energy level of singlet state of the second host is greater than that of the fluorescence compound (second dopant).

55 [0131] When not satisfying this condition, a quenching happens at the first and second dopants or an energy transfer from the host to the dopant does not happen, and thus the quantum efficiency of the OLED D is reduced.

[0132] For example, the second host, which is included in the second layer 344 with the fluorescence compound, may be same as a material of the HBL 350. In this instance, the second layer 344 may have a hole blocking function with an

emission function. Namely, the second layer 344 may serve as a buffer layer for blocking the hole. When the HBL 350 is omitted, the second layer 344 serves as an emitting layer and a hole blocking layer.

5 [0133] When the first layer 342 includes the fluorescence compound and the second layer 344 includes the delayed fluorescent compound, the first host of the first layer 342 may be same as a material of the EBL 330. In this instance, the first layer 342 may have an electron blocking function with an emission function. Namely, the first layer 342 may serve as a buffer layer for blocking the electron. When the EBL 330 is omitted, the first layer 342 serves as an emitting layer and an electron blocking layer.

[0134] FIG. 5 is a schematic-cross sectional view of an OLED according to a third embodiment of the present disclosure.

10 [0135] As shown in FIG. 5, an OLED D includes the first and second electrodes 160 and 164, which face each other, and the organic emitting layer 162 therebetween. The organic emitting layer 162 includes an EML 440, which includes first to third layers 442, 444 and 446 and is positioned between the first and second electrodes 160 and 164, a HTL 420 between the first electrode 160 and the EML 440 and an ETL 460 between the second electrode 164 and the EML 440.

[0136] In addition, the organic emitting layer 162 may further include a HIL 410 between the first electrode 160 and the HTL 420 and an EIL 470 between the second electrode 164 and the ETL 460.

15 [0137] Moreover, the organic emitting layer 162 may further include an EBL 430 between the HTL 420 and the EML 440 and a HBL 450 between the EML 440 and the ETL 460.

[0138] In the EML 440, the first layer 442 is positioned between the second layer 444 and the third layer 446. Namely, the second layer 444 is positioned between the EBL 430 and the first layer 442, and the third layer 446 is positioned between the first layer 442 and the HBL 450.

20 [0139] The first layer 442 (e.g., a first emitting material layer) includes the delayed fluorescent compound of the present disclosure as a dopant (a delayed fluorescent dopant), and each of the second layer 344 (e.g., a second emitting material layer) and the third layer 446 (e.g., a third emitting material layer) may include the fluorescence compound as a dopant (first and second fluorescent dopants). The fluorescence compound in the second and third layers 444 and 446 may be same or different. The delayed fluorescent compound has an energy level of singlet state being larger than the fluorescence material.

25 [0140] In the OLED D, the energy level of singlet state and the energy level of triplet state of the delayed fluorescent compound in the first layer 442 are transferred into the fluorescence compound in the second layer 444 and/or the third layer 446 such that the emission is generated from the fluorescence compound. As a result, the quantum efficiency of the OLED D is increased, and the FWHM of the OLED D is narrowed.

30 [0141] The first to third layers 442, 444 and 446 may further include first to third host, respectively. The first to third hosts are same material or different materials. Each of the first to third hosts may be selected from the materials of Formula 3. Alternatively, the first host may be selected from the materials of Formula 3, while each of the second and third hosts may be common host compound.

35 [0142] In each of the first to third layers 442, 444 and 446, the first to third hosts may have a percentage by weight being larger than the delayed fluorescent compound and the fluorescence compound, respectively. In addition, the percentage by weight of the delayed fluorescent compound (i.e., the first dopant) in the first layer 442 may be greater than that of each of the fluorescence compound (i.e., the second dopant) in the second layer 444 and the fluorescence compound (i.e., the third dopant) in the third layer 446.

40 [0143] The energy level of singlet state of the first host is greater than that of the delayed fluorescent compound (i.e., the first dopant), and the energy level of triplet state of the first host is greater than that of the delayed fluorescent compound. In addition, the energy level of singlet state of the second host is greater than that of the fluorescence compound (i.e., the second dopant) in the second layer 444, and the energy level of singlet state of the third host is greater than that of the fluorescence compound (i.e., the third dopant) in the third layer 446.

45 [0144] For example, the second host in the second layer 444 may be same as a material of the EBL 430. In this instance, the second layer 444 may have an electron blocking function with an emission function. Namely, the second layer 444 may serve as a buffer layer for blocking the electron. When the EBL 430 is omitted, the second layer 444 serves as an emitting layer and an electron blocking layer.

50 [0145] The third host in the third layer 446 may be same as a material of the HBL 450. In this instance, the third layer 446 may have a hole blocking function with an emission function. Namely, the third layer 446 may serve as a buffer layer for blocking the hole. When the HBL 450 is omitted, the third layer 446 serves as an emitting layer and a hole blocking layer.

55 [0146] The second host in the second layer 444 may be same as a material of the EBL 430, and the third host in the third layer 446 may be same as a material of the HBL 450. In this instance, the second layer 444 may have an electron blocking function with an emission function, and the third layer 446 may have a hole blocking function with an emission function. Namely, the second layer 444 may serve as a buffer layer for blocking the electron, and the third layer 446 may serve as a buffer layer for blocking the hole. When the EBL 430 and the HBL 450 are omitted, the second layer 444 serves as an emitting layer and an electron blocking layer and the third layer 446 serves as an emitting layer and a hole blocking layer.

[0147] It will be apparent to those skilled in the art that various modifications and variations can be made in the present disclosure without departing from the scope of the present disclosure. Thus, it is intended that the present disclosure cover the modifications and variations of the present disclosure provided they come within the scope of the appended claims.

5

Claims

1. A delayed fluorescent compound of Formula:

10

15

20

25

30

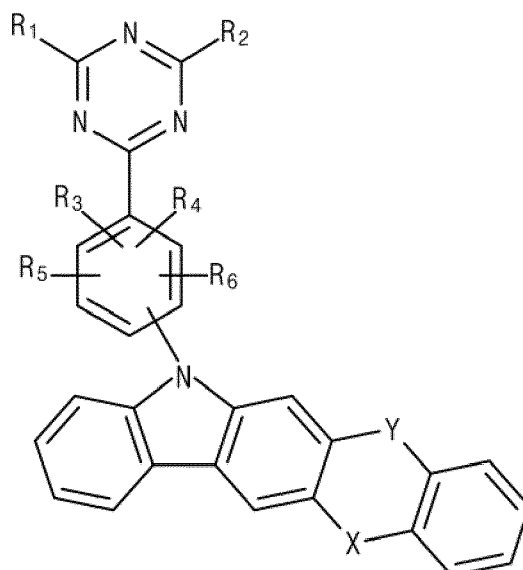

wherein each of R_1 to R_6 is independently selected from the group consisting of hydrogen, deuterium, halogen, cyano group, C1 to C20 alkyl group and C6 to C30 aryl group, and each of X and Y is independently selected from the group consisting of NR_7 , CR_8R_9 , O, S and $SiR_{10}R_{11}$, and wherein at least one of X and Y is NR_7 , and each of R_7 , R_8 , R_9 , R_{10} and R_{11} is independently selected from the group consisting of hydrogen, C1 to C20 alkyl group, C1 to C20 alkoxy group, C6 to C30 aryl group, C5 to C30 heteroaryl group and C1 to C20 amine group.

35

2. The delayed fluorescent compound according to claim 1, wherein the delayed fluorescent compound is one of the following compounds from:

40

45

50

55

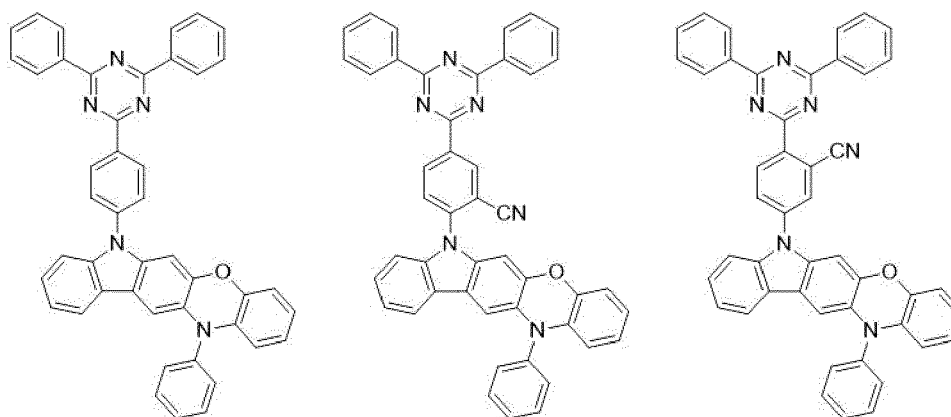

compound 1-1

compound 1-2

compound 1-3

5

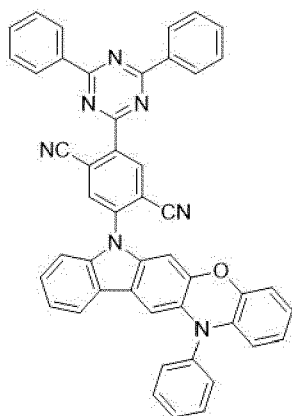

compound 1-4

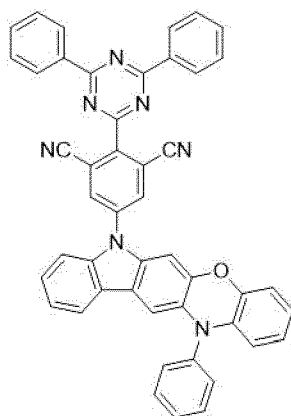

compound 1-5

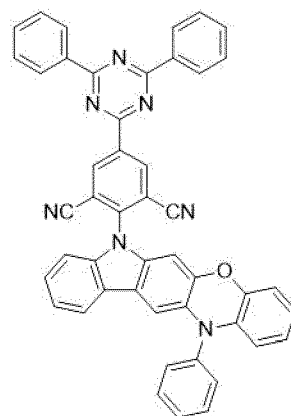

compound 1-6

10

15

20

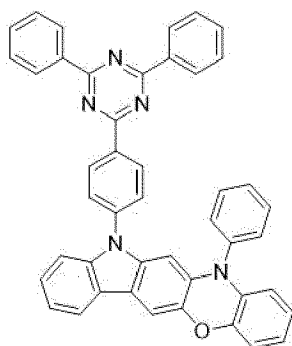

compound 1-7

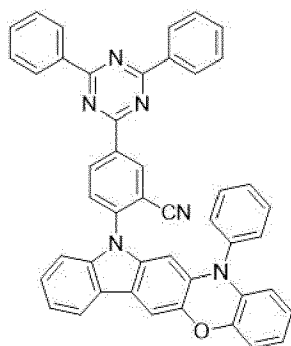

compound 1-8

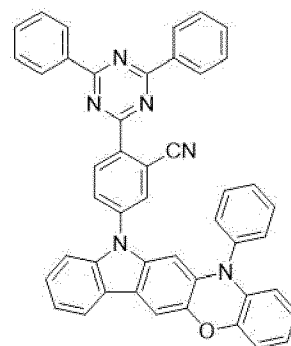

compound 1-9

25

30

35

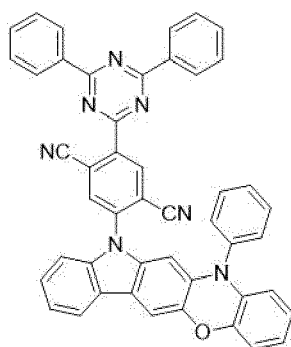

compound 1-10

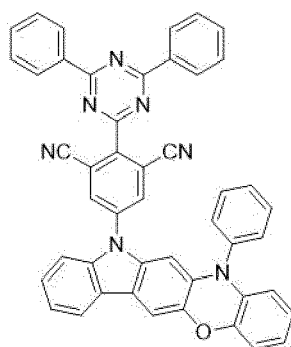

compound 1-11

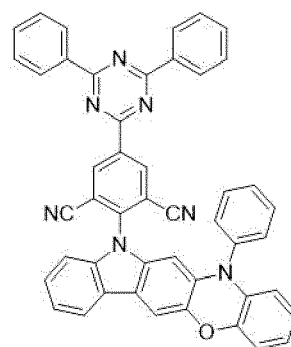

compound 1-12

40

45

50

55

5

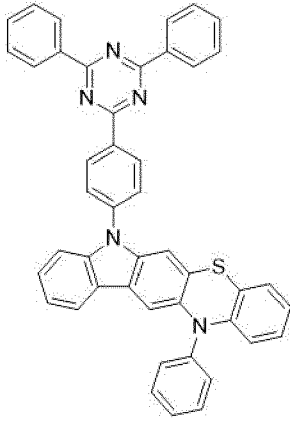

compound 2-1

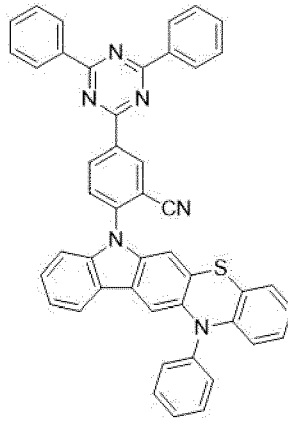

compound 2-2

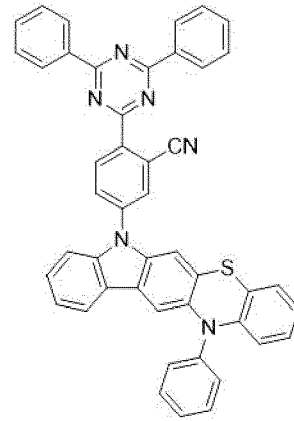

compound 2-3

10

15

20

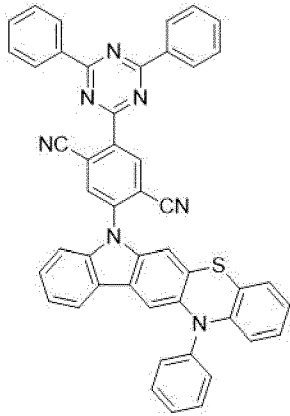

compound 2-4

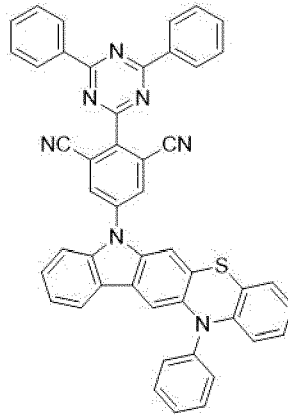

compound 2-5

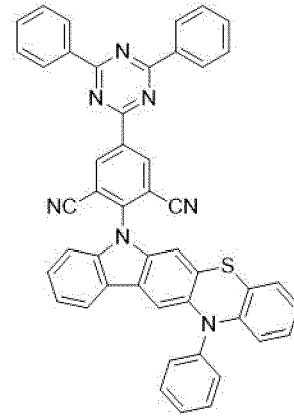

compound 2-6

25

30

35

40

45

50

55

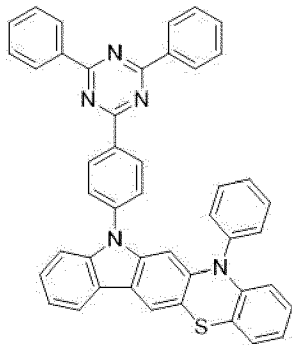

compound 2-7

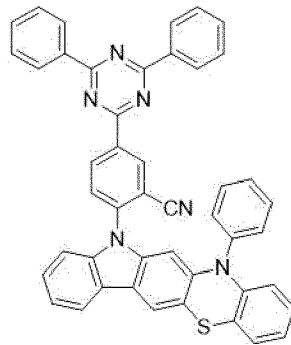

compound 2-8

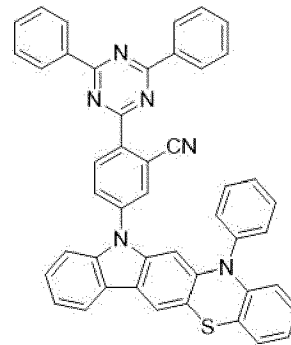

compound 2-9

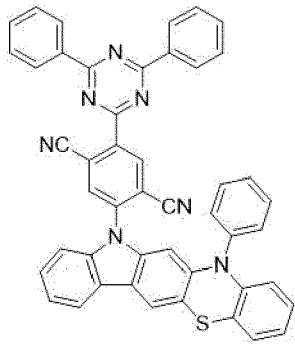

compound 2-10

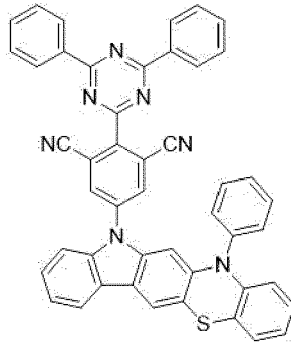

compound 2-11

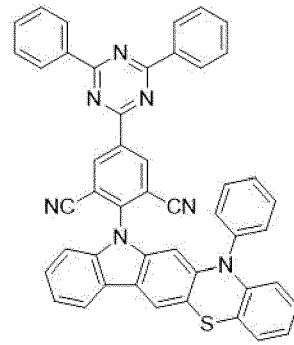

compound 2-12

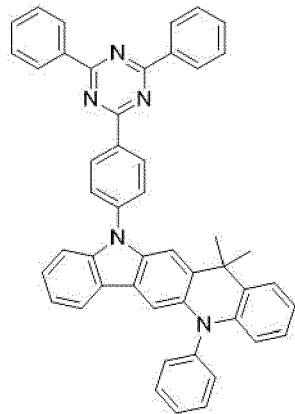

compound 3-1

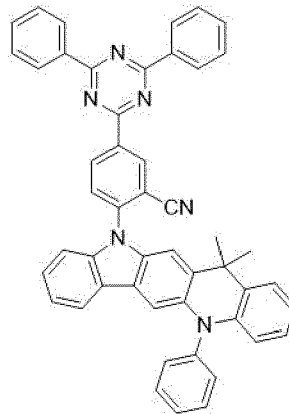

compound 3-2

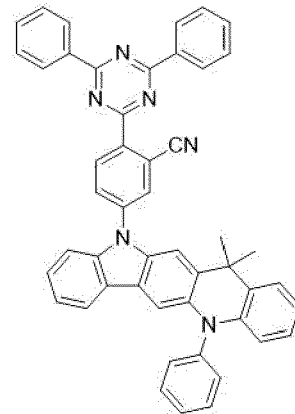

compound 3-3

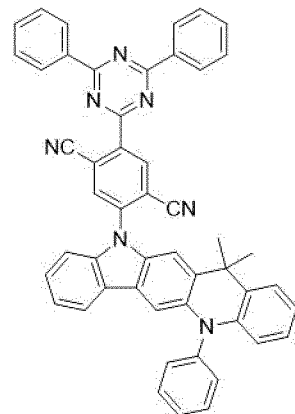

compound 3-4

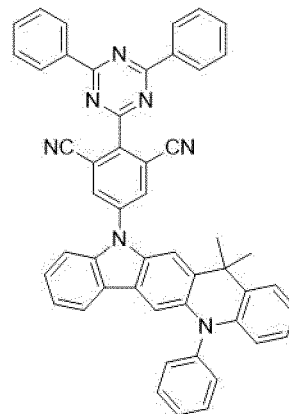

compound 3-5

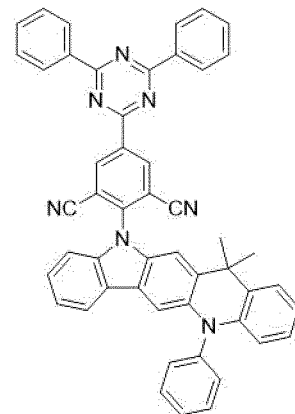

compound 3-6

5

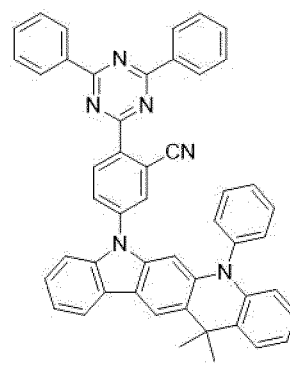
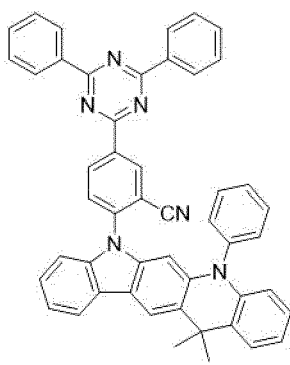
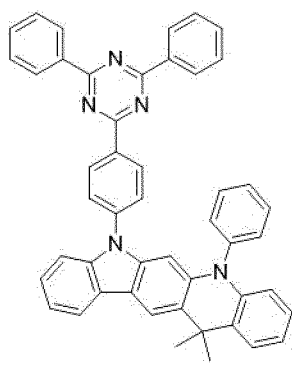

10

15

compound 3-7

compound 3-8

compound 3-9

20

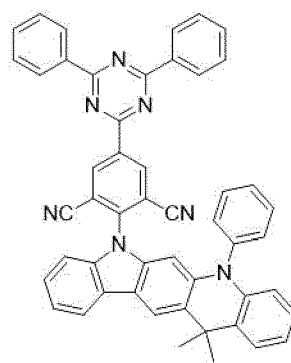
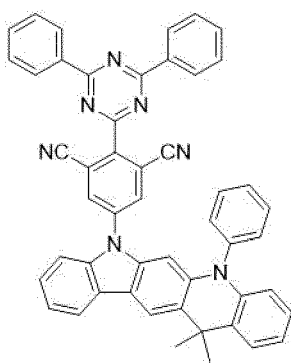
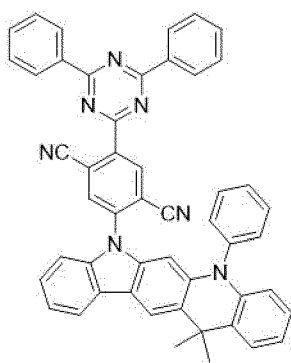

25

30

compound 3-10

compound 3-11

compound 3-12

35

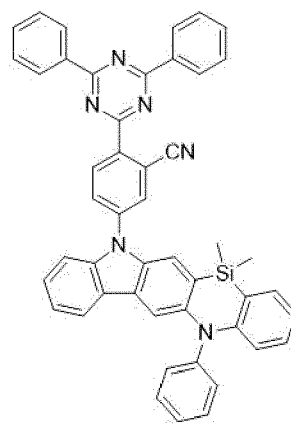
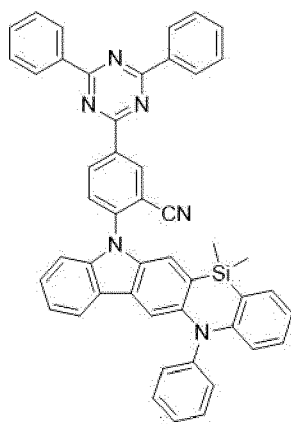
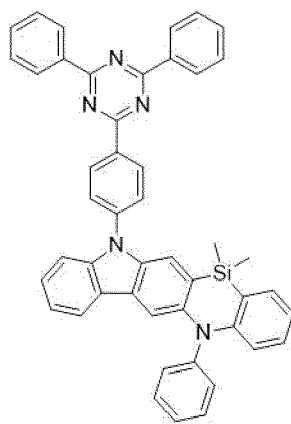

40

45

compound 4-1

compound 4-2

compound 4-3

50

55

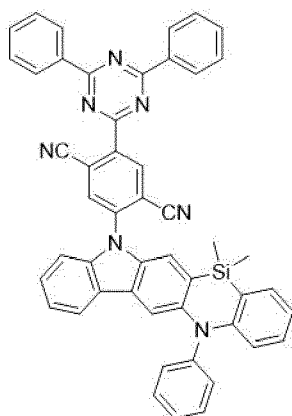

compound 4-4

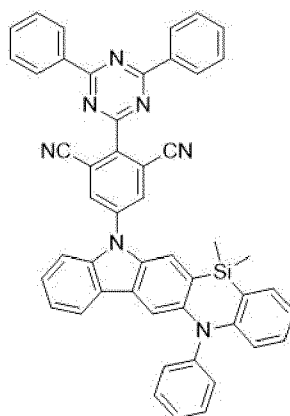

compound 4-5

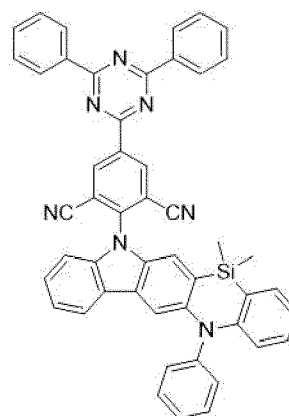

compound 4-6

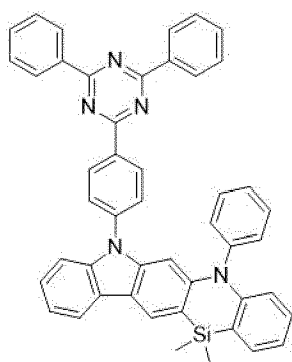

compound 4-7

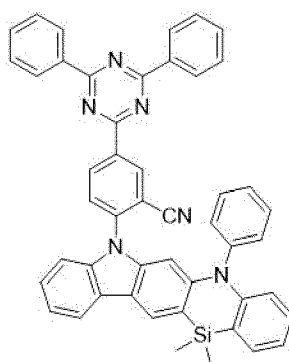

compound 4-8

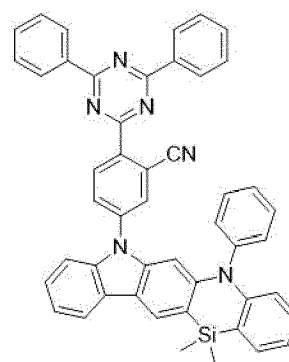

compound 4-9

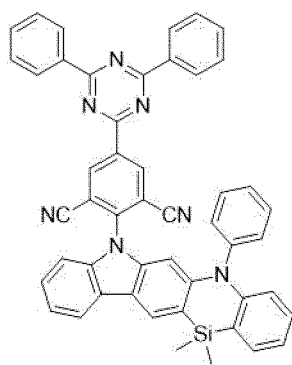

compound 4-10

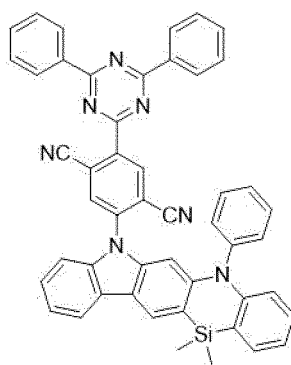

compound 4-11

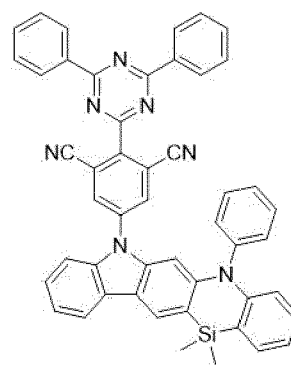

compound 4-12

5

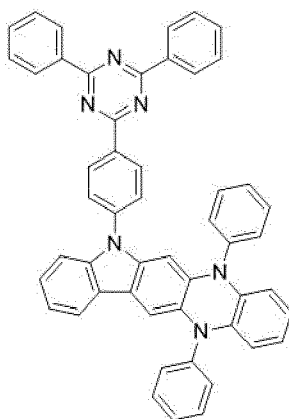

compound 5-1

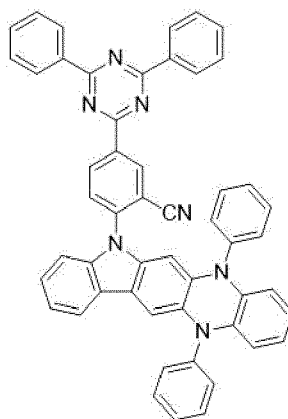

compound 5-2

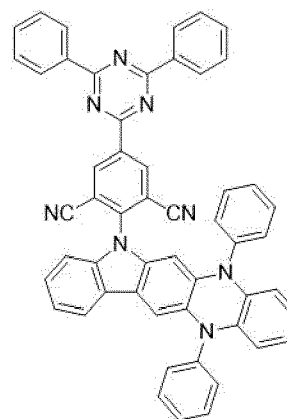

compound 5-3

10

15

20

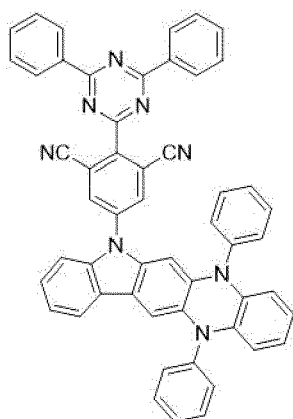

compound 5-4

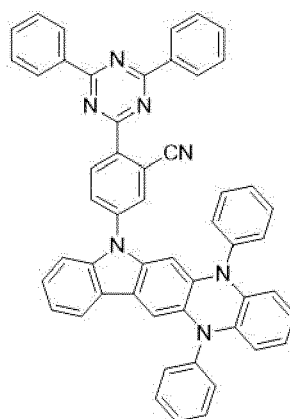

compound 5-5

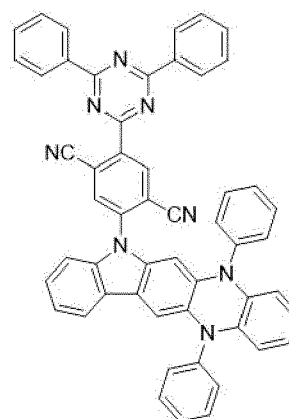

compound 5-6

25

30

35

3. An organic light emitting diode (D), comprising:

a first electrode (160);

a second electrode (164) facing the first electrode (160); and

a first emitting material layer positioned between the first and second electrodes (160, 164) and including a delayed fluorescent compound according to claim 1 or 2.

4. The organic light emitting diode (D) according to claim 3, wherein the delayed fluorescent compound is used as a first dopant, and the first emitting material layer further includes a first host.

5. The organic light emitting diode according to claim 4, wherein a difference between an energy level of a highest occupied molecular orbital of the first host and an energy level of a highest occupied molecular orbital of the first dopant or a difference between an energy level of a lowest unoccupied molecular orbital of the first host and an energy level of a lowest unoccupied molecular orbital of the first dopant is less than about 0.5 eV.

6. The organic light emitting diode (D) according to claim 4 or 5, wherein the first host is selected from the group consisting of:

55

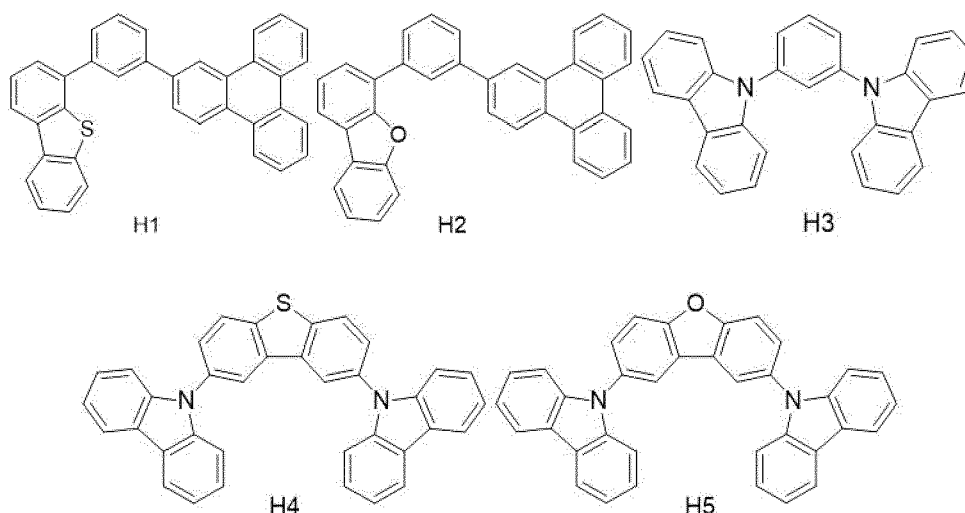

- 20
7. The organic light emitting diode (D) according to any one of claims 4 to 6, wherein the first emitting material layer further includes a second dopant, and wherein an energy level of singlet state of the first dopant is greater than an energy level of singlet state of the second dopant.
- 25
8. The organic light emitting diode according to claim 7, wherein an energy level of triplet state of the first dopant is smaller than an energy level of triplet state of the first host and greater than an energy level of triplet state of the second dopant.
- 30
9. The organic light emitting diode (D) according to any one of claims 4 to 8, further comprising a second emitting material layer positioned between the first emitting material layer and the first electrode (160) and including a second host and a first fluorescent dopant.
- 35
10. The organic light emitting diode (D) according to claim 9, further comprising:
an electron blocking layer between the first electrode (160) and the second emitting material layer,
wherein the second host is same as a material of the electron blocking layer.
- 40
11. The organic light emitting diode (D) according to claim 9, further comprising a third emitting material layer positioned between the first emitting material layer and the second electrode (164) and including a third host and a second fluorescent dopant.
- 45
12. The organic light emitting diode (D) according to claim 11, further comprising:
a hole blocking layer between the second electrode (164) and the third emitting material layer,
wherein the third host is same as a material of the hole blocking layer.
- 50
13. The organic light emitting diode (D) according to claim 11 or 12,
wherein:
an energy level of singlet state of the first dopant is greater than each of an energy level of singlet state of the first fluorescent dopant and an energy level of singlet state of the second fluorescent dopant; and/or
wherein:
an energy level of singlet state and an energy level of triplet state of the first host are greater than an energy level of singlet state and an energy level of triplet state of the first dopant, respectively, and
an energy level of singlet state of the second host is greater than an energy level of singlet state of the first fluorescent dopant, and an energy level of singlet state of the third host is greater than an energy level of singlet state of the second fluorescent dopant.
- 55

14. The organic light emitting diode (D) according to claim 9,
wherein:

5

an energy level of singlet state of the first dopant is greater than an energy level of singlet state of the first
fluorescent dopant; and/or
wherein:

10

an energy level of singlet state and an energy level of triplet state of the first host are greater than an energy
level of singlet state and an energy level of triplet state of the first dopant, respectively, and
wherein an energy level of singlet state of the second host is greater than an energy level of singlet state
of the first fluorescent dopant.

15. An organic light emitting display device (100), comprising:

15

a substrate (110); and
an organic light emitting diode (D) according to any one of claims 3 to 14 on the substrate (110).

20

25

30

35

40

45

50

55

FIG. 1

100

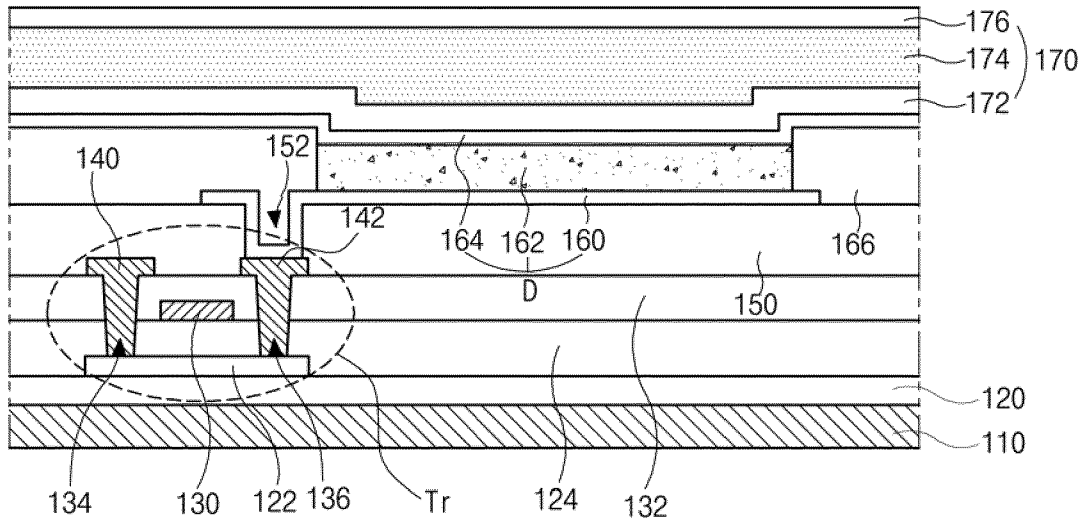

FIG. 2

D

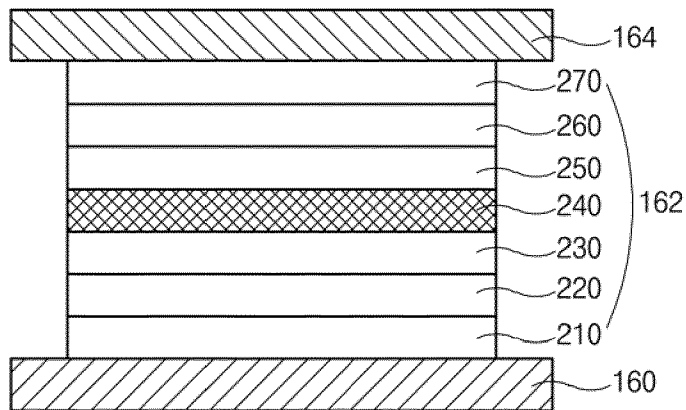

FIG. 3

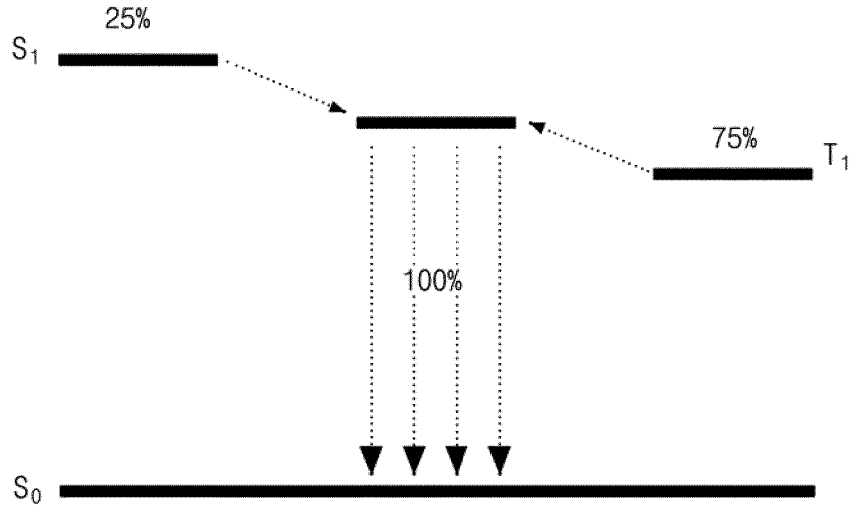

FIG. 4

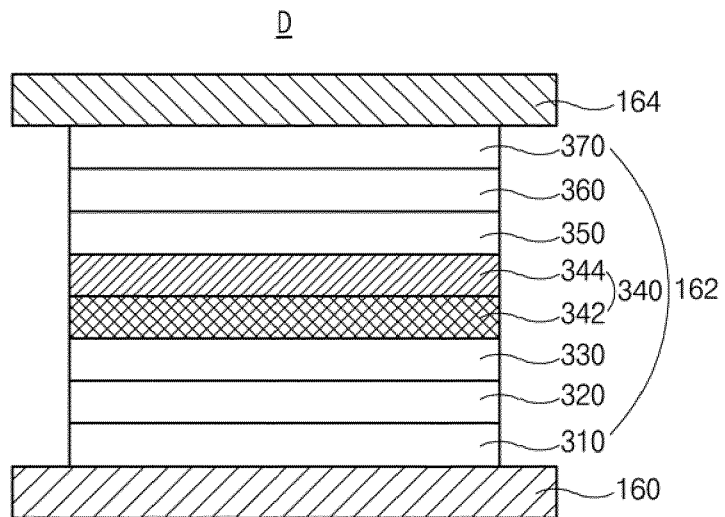
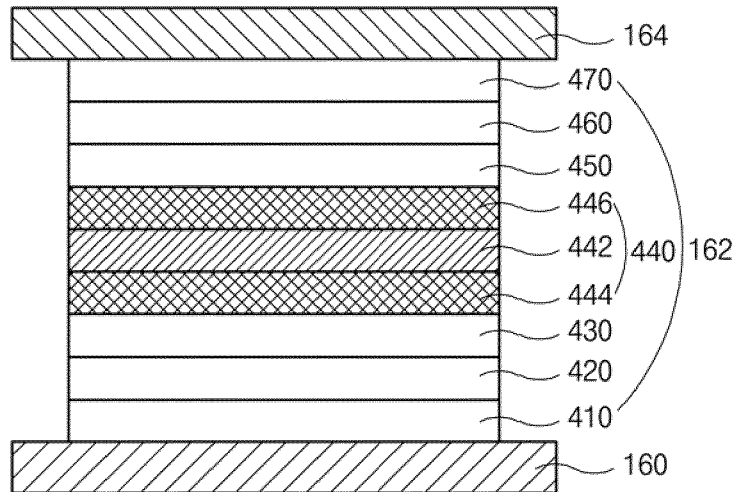

FIG. 5

D





EUROPEAN SEARCH REPORT

Application Number
EP 19 21 3201

5

10

15

20

25

30

35

40

45

50

55

| DOCUMENTS CONSIDERED TO BE RELEVANT | | | |
|--|--|--|---|
| Category | Citation of document with indication, where appropriate, of relevant passages | Relevant to claim | CLASSIFICATION OF THE APPLICATION (IPC) |
| X | CHEN JIA-XIONG ET AL: "Highly efficient thermally activated delayed fluorescence emitters based on novel Indolo[2,3-b]acridine electron-donor", ORGANIC ELECTRONICS, ELSEVIER, AMSTERDAM, NL, vol. 57, 13 March 2018 (2018-03-13), pages 327-334, XP085378326, ISSN: 1566-1199, DOI: 10.1016/J.ORGEL.2018.03.024 | 1-5,15 | INV. H01L51/54 |
| A | * page 332, left-hand column, lines 3-5; table 1; compounds IDAC-Trz * | 6-14 | |
| X | KR 2015 0111271 A (CS ELSOLAR CO LTD [KR]) 5 October 2015 (2015-10-05) * abstract; compound 22 * | 1,3,4,15 | |
| A | US 2016/190474 A1 (KIM SEHUN [KR] ET AL) 30 June 2016 (2016-06-30) * compounds 4,29 * | 1-15 | |
| | | | TECHNICAL FIELDS SEARCHED (IPC) |
| | | | H01L |
| The present search report has been drawn up for all claims | | | |
| Place of search The Hague | | Date of completion of the search 3 April 2020 | Examiner Welter, Steve |
| CATEGORY OF CITED DOCUMENTS X : particularly relevant if taken alone Y : particularly relevant if combined with another document of the same category A : technological background O : non-written disclosure P : intermediate document T : theory or principle underlying the invention E : earlier patent document, but published on, or after the filing date D : document cited in the application L : document cited for other reasons & : member of the same patent family, corresponding document | | | |

EPO FORM 1503 03/82 (P04C01)

**ANNEX TO THE EUROPEAN SEARCH REPORT
ON EUROPEAN PATENT APPLICATION NO.**

EP 19 21 3201

5 This annex lists the patent family members relating to the patent documents cited in the above-mentioned European search report.
The members are as contained in the European Patent Office EDP file on
The European Patent Office is in no way liable for these particulars which are merely given for the purpose of information.

03-04-2020

10

| Patent document cited in search report | Publication date | Patent family member(s) | Publication date |
|--|------------------|--------------------------------------|--------------------------|
| KR 20150111271 A | 05-10-2015 | NONE | |
| US 2016190474 A1 | 30-06-2016 | KR 20160080309 A US 2016190474 A1 | 08-07-2016 30-06-2016 |

15

20

25

30

35

40

45

50

55

EPO FORM P0459

For more details about this annex : see Official Journal of the European Patent Office, No. 12/82

REFERENCES CITED IN THE DESCRIPTION

This list of references cited by the applicant is for the reader's convenience only. It does not form part of the European patent document. Even though great care has been taken in compiling the references, errors or omissions cannot be excluded and the EPO disclaims all liability in this regard.

Patent documents cited in the description

- KR 1020180160974 [0001]

| | | | |
|----------------|---|---------|------------|
| 专利名称(译) | 延迟荧光化合物，有机发光二极管和有机发光显示装置 | | |
| 公开(公告)号 | EP3667756A1 | 公开(公告)日 | 2020-06-17 |
| 申请号 | EP2019213201 | 申请日 | 2019-12-03 |
| [标]申请(专利权)人(译) | 乐金显示有限公司 | | |
| 申请(专利权)人(译) | LG DISPLAY CO. , LTD. | | |
| 当前申请(专利权)人(译) | LG DISPLAY CO. , LTD. | | |
| [标]发明人 | BAE SUK YOUNG SHIN IN AE KIM JUN YUN | | |
| 发明人 | BAE, SUK-YOUNG SHIN, IN-AE KIM, JUN-YUN CHOE, IK-RANG | | |
| IPC分类号 | H01L51/54 | | |
| CPC分类号 | H01L51/0067 H01L51/0071 H01L51/0072 H01L51/0094 H01L51/5012 C07D471/04 C07D487/04 C07D498/04 C07D513/04 C07F7/0816 H01L51/0054 H01L51/0073 H01L51/0074 H01L51/5096 | | |
| 审查员(译) | 韦尔特，史蒂夫 | | |
| 优先权 | 1020180160974 2018-12-13 KR | | |
| 外部链接 | Espacenet | | |

摘要(译)

本公开提供了下式的延迟荧光化合物，以及有机发光二极管 (D)，其包括第一电极 (160)，第二电极 (164) 以及在第一电极和第二电极 (160、164 之间) 的有机发光层。)，其中延迟的荧光化合物包括在有机发光层中，以及包括该有机发光化合物的有机发光显示装置 (100)。

FIG. 1

