



(12) **EUROPEAN PATENT APPLICATION**

(88) Date of publication A3:  
**20.01.2016 Bulletin 2016/03**

(51) Int Cl.:  
**H01L 27/32** (2006.01) **G03F 7/00** (2006.01)  
**H01L 51/56** (2006.01) **B41M 5/46** (2006.01)

(43) Date of publication A2:  
**02.04.2014 Bulletin 2014/14**

(21) Application number: **13168105.8**

(22) Date of filing: **16.05.2013**

(84) Designated Contracting States:  
**AL AT BE BG CH CY CZ DE DK EE ES FI FR GB GR HR HU IE IS IT LI LT LU LV MC MK MT NL NO PL PT RO RS SE SI SK SM TR**  
 Designated Extension States:  
**BA ME**

(72) Inventors:  
 • **Son, Young Tae**  
**411-821 Goyang-si, Gyeonggi-do (KR)**  
 • **Kim, Jin Wuk**  
**Goyang-si, Gyeonggi-do 411-736 (KR)**  
 • **Kim, Wy-Yong**  
**152-785 Seoul (KR)**

(30) Priority: **27.09.2012 KR 20120108349**  
**10.04.2013 KR 20130039167**

(74) Representative: **Ter Meer Steinmeister & Partner**  
**Patentanwälte mbB**  
**Nymphenburger Straße 4**  
**80335 München (DE)**

(54) **Organic light emitting display device and method for manufacturing the same**

(57) Disclosed is a method of manufacturing an organic light emitting display device. The method include forming a driving thin film transistor and passivation layer on a substrate, forming a bank layer at a boundary portion between adjacent sub-pixels, on the passivation layer, laminating a first photoresist film on the bank layer, forming a first photoresist pattern by irradiating IR light on the first photoresist film in an area except a first sub-pixel, depositing a first organic emission layer in the first sub-

pixel area exposed by the first photoresist pattern, removing the first photoresist pattern, laminating a second photoresist film on the bank layer, forming a second photoresist pattern by irradiating IR light on the second photoresist film in an area except a second sub-pixel, depositing a second organic emission layer in the second sub-pixel area exposed by the second photoresist pattern, and removing the second photoresist pattern.

**FIG. 6**

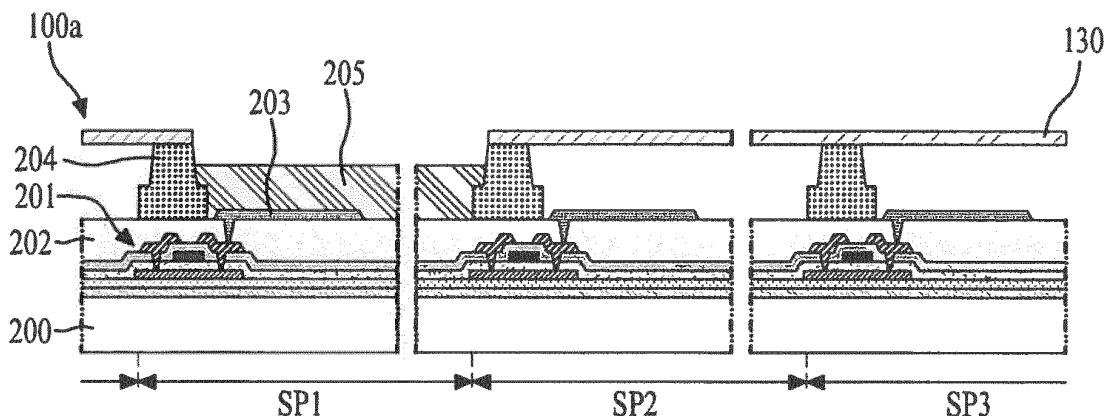



EUROPEAN SEARCH REPORT

Application Number  
EP 13 16 8105

5

10

15

20

25

30

35

40

45

50

55

DOCUMENTS CONSIDERED TO BE RELEVANT			
Category	Citation of document with indication, where appropriate, of relevant passages	Relevant to claim	CLASSIFICATION OF THE APPLICATION (IPC)
X	US 2009/184636 A1 (COK RONALD S [US]) 23 July 2009 (2009-07-23) * the whole document *	1-15	INV. H01L27/32 G03F7/00 H01L51/56
X	US 2007/252525 A1 (SEKI SHUNICHI [JP]) 1 November 2007 (2007-11-01) * paragraph [0129] - paragraph [0163] *	15	ADD. B41M5/46
A	* figure 18 *	1-14	
A	JP 2005 003979 A (TOYO BOSEKI) 6 January 2005 (2005-01-06) * the whole document *	7,9,10	
A	ETIENNE MENARD ET AL: "Micro- and Nanopatterning Techniques for Organic Electronic and Optoelectronic Systems", CHEMICAL REVIEWS, AMERICAN CHEMICAL SOCIETY, WASHINGTON, DC, US, vol. 107, January 2007 (2007-01), pages 1117-1160, XP007911140, DOI: 10.1021/CRO50139Y [retrieved on 2007-11-04] * pages 1146-1148, chapter 4.2 *	7,9,10	
			TECHNICAL FIELDS SEARCHED (IPC)
			H01L G03F B41M
The present search report has been drawn up for all claims			
Place of search Munich		Date of completion of the search 10 December 2015	Examiner Bruckmayer, Manfred
CATEGORY OF CITED DOCUMENTS X : particularly relevant if taken alone Y : particularly relevant if combined with another document of the same category A : technological background O : non-written disclosure P : intermediate document		T : theory or principle underlying the invention E : earlier patent document, but published on, or after the filing date D : document cited in the application L : document cited for other reasons ..... & : member of the same patent family, corresponding document	

EPO FORM 1503 03.02 (P04C01)

**ANNEX TO THE EUROPEAN SEARCH REPORT  
ON EUROPEAN PATENT APPLICATION NO.**

EP 13 16 8105

5

This annex lists the patent family members relating to the patent documents cited in the above-mentioned European search report. The members are as contained in the European Patent Office EDP file on The European Patent Office is in no way liable for these particulars which are merely given for the purpose of information.

10

10-12-2015

15

20

25

30

35

40

45

50

55

Patent document cited in search report	Publication date	Patent family member(s)	Publication date
US 2009184636 A1	23-07-2009	NONE	
-----			
US 2007252525 A1	01-11-2007	JP 2007242592 A	20-09-2007
		KR 20070079569 A	07-08-2007
		US 2007252525 A1	01-11-2007
-----			
JP 2005003979 A	06-01-2005	NONE	
-----			

EPO FORM P0459

For more details about this annex : see Official Journal of the European Patent Office, No. 12/82

专利名称(译)	有机发光显示装置及其制造方法		
公开(公告)号	<a href="#">EP2713399A3</a>	公开(公告)日	2016-01-20
申请号	EP2013168105	申请日	2013-05-16
[标]申请(专利权)人(译)	乐金显示有限公司		
申请(专利权)人(译)	LG DISPLAY CO. , LTD.		
当前申请(专利权)人(译)	LG DISPLAY CO. , LTD.		
[标]发明人	SON YOUNG TAE KIM JIN WUK KIM WY YONG		
发明人	SON, YOUNG TAE KIM, JIN WUK KIM, WY-YONG		
IPC分类号	H01L27/32 G03F7/00 H01L51/56 B41M5/46		
CPC分类号	G03F7/0035 H01L27/3246 H01L51/56 H01L2227/323		
优先权	1020120108349 2012-09-27 KR 1020130039167 2013-04-10 KR		
其他公开文献	EP2713399A2		
外部链接	<a href="#">Espacenet</a>		

摘要(译)

公开了一种制造有机发光显示装置的方法。该方法包括在基板上形成驱动薄膜晶体管 and 钝化层，在相邻子像素之间的边界部分处形成堤层，在钝化层上，在堤层上层叠第一光刻胶膜，形成第一光刻胶图案通过在除第一子像素之外的区域中的第一光刻胶膜上照射IR光，在由第一光刻胶图案暴露的第一子像素区域中沉积第一有机发光层，去除第一光刻胶图案，层压第二光刻胶膜在堤层上，通过在除第二子像素之外的区域中的第二光刻胶膜上照射IR光，在由第二光刻胶图案暴露的第二子像素区域中沉积第二有机发光层，形成第二光刻胶图案，以及去除第二光刻胶图案。

