



(11) **EP 1 601 033 B1**

(12) **EUROPEAN PATENT SPECIFICATION**

(45) Date of publication and mention of the grant of the patent:
26.10.2016 Bulletin 2016/43

(51) Int Cl.:
H01L 27/32^(2006.01) H01L 51/56^(2006.01)

(21) Application number: **05104331.3**

(22) Date of filing: **23.05.2005**

(54) **Organic light emitting display device and method of fabricating the same**

Organische lichtemittierende Vorrichtung und Herstellungsverfahren

Dispositif émetteur organique de lumière et méthode de fabrication

(84) Designated Contracting States:
AT BE BG CH CY CZ DE DK EE ES FI FR GB GR HU IE IS IT LI LT LU MC NL PL PT RO SE SI SK TR

(30) Priority: **25.05.2004 KR 2004037555**

(43) Date of publication of application:
30.11.2005 Bulletin 2005/48

(73) Proprietor: **Samsung Display Co., Ltd. Gyeonggi-do (KR)**

(72) Inventor: **LEE, Kwan-Hee Gyeonggi-do (KR)**

(74) Representative: **Gulde & Partner Patent- und Rechtsanwaltskanzlei mbB Wallstraße 58/59 10179 Berlin (DE)**

(56) References cited:
EP-A- 1 102 317 EP-A2- 1 096 568
KR-A- 20040 042 855 US-A- 5 742 129
US-A1- 2002 093 286 US-A1- 2002 187 265
US-A1- 2003 189 400

EP 1 601 033 B1

Note: Within nine months of the publication of the mention of the grant of the European patent in the European Patent Bulletin, any person may give notice to the European Patent Office of opposition to that patent, in accordance with the Implementing Regulations. Notice of opposition shall not be deemed to have been filed until the opposition fee has been paid. (Art. 99(1) European Patent Convention).

Description

BACKGROUND OF THE INVENTION

Field of the Invention

[0001] The present invention relates to flat panel displays (FPDs) generally and, more particularly, to an organic light emitting display (OLED) device and method of fabricating the same.

Description of the Related Art

[0002] Flat panel displays (FPDs) incorporating light emitting diodes (LEDs) have garnered much attention as replacements for conventional cathode ray tube (CRT) displays. An LED is an electronic device fabricated by positioning a series of thin films between two conductors. The thin films emit bright light when current is applied to the conductors. Even with multiple layers, LEDs are very thin and can be used to produce thin FPDs that are self-luminous, *e.g.*, do not require backlighting. If the thin films sandwiched between the conductors are formed of organic materials, a flat panel organic electroluminescent display (OLED) device may be produced. Such OLED devices have wider viewing angles, faster video response speeds, and lower power consumption than CRT displays. Other advantages of OLED devices over CRT displays include increased brightness, lighter weight, improved durability, and expanded ranges of operating temperatures. Exemplary embodiments of OLEDs of the prior art are disclosed in JP 2002 151255, US 2003/189400 A1, EP 1 096 568 A2, KR 2004 0042844 A and US 2004/135501 A1.

[0003] FIG. 1A and FIG. 1B are plan views illustrating a method of fabricating a conventional OLED device, and FIG. 2A and FIG. 2B are cross-sectional views taken along lines I-I of FIG. 1A and FIG. 1B, respectively.

[0004] Referring to FIG. 1A and FIG. 2A, anodes 3 are formed on an insulating substrate 1 including red (R), green (G), and blue (B) unit pixel regions R, G, and B. Each of the anodes 3 is located in one of the unit pixel regions R, G, and B. A pixel defining layer 2 is formed on the anode 3 such that it has an opening 2a exposing a portion of the surface of the anode 3. The opening 2a defines an emission region E. A hole injection/transport layer 4 is formed on the entire surface of the substrate 1 having the opening 2a.

[0005] Thereafter, a fine metal mask 9 is located on the substrate 1 where the hole injection/transport layer 4 is formed such that the mask has a slit exposing the red unit pixel region R. The fine metal mask 9 is adhered to the substrate 1 using a vacuum absorption process. Then, a red emission layer 5R is deposited using the fine metal mask 9 as a mask. Thus, the red emission layer 5R is formed on the hole injection/transport layer 4 in the red unit pixel region R.

[0006] Referring to FIG. 1B and FIG. 2B, after the red

emission layer 5R is formed, the fine metal mask 9 is removed. During this process, a crack C may form in a portion (S of FIG. 2A) of the hole injection/transport layer 4, which adheres to an edge of the slit of the fine metal mask 9. Generally, the edge of the slit of the fine metal mask 9 is rough, and this rough edge may make the crack C worse. The crack C may also form in the underlying pixel defining layer 2 through the hole injection/transport layer 4. Also, when the hole injection/transport layer 4 is not formed, the crack C may form directly in the pixel defining layer 2.

[0007] After the fine metal mask 9 is removed, a green emission layer 5G and a blue emission layer 5B are formed on the green and blue unit pixel regions G and B, respectively, in the same manner as when the red emission layer 5R is formed. Likewise, cracks may be formed in the hole injection/transport layer 4 or the pixel defining layer 2 on both sides of each of the green and blue emission layers 5G and 5B.

[0008] Subsequently, a cathode 6 is formed on the emission layers 5R, 5G, and 5B. However, if a crack C was formed, it may thin or sever the portion of the cathode 6 that overlays the crack C. In either case, the cathode 6 is weakened. The weakened cathode regions may result in some disadvantages, such as a unit pixel reduction phenomenon that reduces the amount of light emitted from an edge portion of a unit pixel during the operation of the OLED device.

SUMMARY OF THE INVENTION

[0009] The present invention may solve the aforementioned problems and/or overcome the disadvantages associated with manufacturing and/or operating conventional OLED devices by providing an OLED device and method of fabricating the same that suppress and/or eliminate the unit pixel reduction phenomenon.

[0010] The present invention discloses an organic light emitting display device as defined in the claims. The OLED of the invention comprises: unit pixel regions arranged on a substrate, the unit pixel regions including red unit pixel regions, green unit pixel regions, and blue unit pixel regions being arranged in a matrix shape, the matrix comprising row of unit pixel regions of alternating colors and columns of unit pixel regions of the same color, each of the unit pixel regions including an emission region and a non-emission region; a pixel electrode disposed at least in the emission region; a pillar disposed between emission regions of adjacent unit pixel regions that emit same-colored light, the pillar protruding upward further than the pixel electrode and the pillar having a height of 1 μm ; an emission layer disposed on the pixel electrode; and an opposite electrode disposed on the emission layer, wherein the width of the pillar is equal to or smaller than a width of the emission region.

[0011] The present invention also discloses a method of fabricating an OLED device comprising: providing a substrate including unit pixel regions, the unit pixel re-

regions including red unit pixel regions, green unit pixel regions, and blue unit pixel regions being arranged in a matrix shape, the matrix comprising row of unit pixel regions of alternating colors and columns of unit pixel regions of the same color, each of the unit pixel regions including an emission region and a non-emission region; forming a pixel electrode on the substrate in the emission region; forming a pillar between emission regions of adjacent unit pixel regions that emit same-colored light; wherein the width of the pillar is equal to or smaller than a width of the emission region, and wherein the pillar has a height of 1 μm ; closely adhering a fine metal mask to the substrate having the pillar, the fine metal mask having a slit that exposes the adjacent unit pixel regions that emit same-colored light; and forming an emission layer on the exposed unit pixel regions.

BRIEF DESCRIPTION OF THE DRAWINGS

[0012] The above and other features of the present invention will be described in reference to certain embodiments thereof with reference to the attached drawings.

FIG. 1A and FIG. 1B are plan views illustrating a method of fabricating a conventional organic light emitting display device (OLED).

FIG. 2A and FIG. 2B are cross-sectional views taken along lines I-I of FIG. 1A and FIG. 1B, respectively.

FIG. 3A and FIG. 3B are plan views illustrating a first method of fabricating an OLED device according to embodiments of the present invention.

FIG. 4A and FIG. 4B are cross-sectional views taken along lines II-II of FIG. 3A and FIG. 3B, respectively, which further illustrate the first method of fabricating an OLED device of the present invention.

FIG. 5A and FIG. 5B are cross-sectional views taken along lines III-III of FIG. 3A and FIG. 3B, respectively, which further illustrate the first method of fabricating an OLED device of the present invention.

FIG. 6A and FIG. 6B are cross-sectional views taken along lines IV-IV of FIG. 3A and FIG. 3B, respectively, which further illustrate the first method of fabricating an OLED device of the present invention.

FIG. 7A and FIG. 7B are cross-sectional views taken along lines V-V of FIG. 3A and FIG. 3B, respectively, which further illustrate the first method of fabricating an OLED device of the present invention.

FIG. 8A and FIG. 8B are cross-sectional views taken along lines II-II of FIG. 3A and FIG. 3B, respectively, which illustrate a second method of fabricating an OLED device of the present invention.

FIG. 9A and FIG. 9B are cross-sectional views taken along lines III-III of FIG. 3A and FIG. 3B, respectively, which further illustrate the method according to another embodiment of the present invention.

FIG. 10A and FIG. 10B are cross-sectional views taken along lines IV-IV of FIG. 3A and FIG. 3B, re-

spectively, which further illustrate the second method of fabricating an OLED device of the present invention.

FIG. 11A and FIG. 11B are cross-sectional views taken along lines V-V of FIG. 3A and FIG. 3B, respectively, which further illustrate the second method of fabricating an OLED device of the present invention.

10 DETAILED DESCRIPTION

[0013] The present invention is described more fully hereinafter with reference to the accompanying drawings, in which embodiments of the invention are shown.

15 The invention may, however, be embodied in different forms and should not be construed as limited to the embodiments set forth herein. Rather, these embodiments are provided so that the disclosure is thorough and complete and fully conveys the scope of the invention to those skilled in the art. The thicknesses of layers or regions shown in the drawings may be exaggerated for clarity, and the same reference numerals may be used to denote the same elements throughout the specification.

[0014] A first method of fabricating an organic light emitting display (OLED) according to an embodiment of the present invention is now described with reference to FIG. 3A, FIG. 3B, FIG. 4A, FIG. 4B, FIG. 5A, FIG. 5B, FIG. 6A, FIG. 6B, FIG. 7A and FIG. 7B. Specifically, FIG. 3A and FIG. 3B are plan views illustrating a method of fabricating an OLED device manufactured in accordance with the principles of the present invention. FIG. 4A and FIG. 4B are cross-sectional views taken along lines II-II of FIG. 3A and FIG. 3B, respectively. FIG. 5A and FIG. 5B are cross-sectional views taken along lines III-III of FIG. 3A and FIG. 3B, respectively. FIG. 6A and FIG. 6B are cross-sectional views taken along lines IV-IV of FIG. 3A and FIG. 3B, respectively. FIG. 7A and FIG. 7B are cross-sectional views taken along lines V-V of FIG. 3A and FIG. 3B, respectively.

40 **[0015]** Referring to FIG. 3A, FIG. 4A, FIG. 5A, FIG. 6A, and FIG. 7A, a substrate 100 on which red (R), green (G), and blue (B) unit pixel regions R, G, and B are arranged is provided. The unit pixel regions R, G, and B may be arranged in a stripe shape. That is, regions that emit same-colored light may be arranged in a column or row. Each of the unit pixel regions R, G, and B includes an emission region E and a non-emission region, which corresponds to a region excluding the emission region E.

[0016] The substrate 100 may be a glass substrate, a plastic substrate, or a quartz substrate. A buffer layer 105 may be formed on the substrate 100. A semiconductor layer 110 is formed on the buffer layer 105 in the non-emission region. The semiconductor layer 110 may be formed of amorphous silicon (a-Si) or poly crystalline silicon (poly-Si). Preferably, the semiconductor layer 110 is formed of poly-Si. The poly-Si semiconductor layer 110 can be obtained by forming a-Si on the substrate 100 and crystallizing the same. The crystallization of the a-

Si may be performed using a metal induced crystallization (MIC) process, a metal induced lateral crystallization (MILC) process, an excimer laser annealing (ELA) process, or a sequential lateral solidification (SLS) process.

[0017] A gate insulating layer 115 may be formed on the semiconductor layer 110, and a gate electrode 120 may be formed on the gate insulating layer 115. Impurity ions may be doped into the semiconductor layer 110 using the gate electrode 120 as a mask, thereby forming source and drain regions 110a and 110b in the semiconductor layer 110. A channel region 110c may be defined between the source region 110a and drain region 110b. An interlayer insulating layer 125 may be formed on the gate electrode 120. A source electrode 130a and drain electrode 130b may be formed on the interlayer insulating layer 125. The source electrode 130a may contact the source region 110a through a first contact hole. The drain electrode 130 may contact the drain region 110b through a second contact hole. In this manner, a thin film transistor (TFT) including the semiconductor layer 110, the gate insulating layer 115, the gate electrode 120, and the source and drain electrodes 130a and 130b may be formed. During the formation of the TFT, a capacitor (not shown) may be formed in the non-emission region.

[0018] A passivation insulating layer 135 may be formed on the source and drain electrodes 130a and 130b. The passivation insulating layer 135 may be an organic layer, an inorganic layer, or a combination thereof. A pixel electrode 140 may be formed on the passivation insulating layer 135 to contact either the source electrode 130a or the drain electrode 130b through a via hole. The pixel electrode 140 may be formed as an anode or a cathode. When the pixel electrode 140 is formed as the anode, it may be made of indium tin oxide (ITO) or indium zinc oxide (IZO). Before the pixel electrode 140 as the anode is formed, a reflective layer may be formed on the passivation insulating layer 135 using one selected from the group consisting of Al, Ag, MoW, AlNd, and Ti. On the other hand, when the pixel electrode 140 is formed as the cathode, it may be made of Mg, Ca, Al, Ag, Ba, or an alloy thereof.

[0019] A pixel defining layer 150 may be formed on the pixel electrode 140 such that it has an opening 150a exposing a portion of the surface of the pixel electrode 140. A region occupied by the opening 150a corresponds to the emission region E. That is, in one embodiment, the emission region E is defined by the opening 150a, and the pixel electrode 140 is located at least in the emission region E. Meanwhile, a pixel driving circuit, which is electrically connected to the pixel electrode 140, may be disposed in the non-emission region. The pixel driving circuit may include the above-described TFT and capacitor.

[0020] The pixel defining layer 150 may be formed of an organic or inorganic layer. When the pixel defining layer 150 is formed of an organic layer, it may be formed of one selected from the group consisting of benzocyclobutene (BCB), acrylic photoresist, phenolic photoresist, and polyimide photoresist. However, the present in-

vention is not limited to the materials or configurations described above.

[0021] Referring briefly to FIG. 6A and FIG. 7A, a pillar 155 may be formed on the pixel defining layer 150 or at any other suitable location. The pillar 155 is formed between emission regions of adjacent unit pixel regions that emit the same-colored light. Also, a length 155L of the pillar 155 may be equal to or smaller than a distance E_d (FIG. 3A) between the emission regions of the adjacent unit pixel regions that emit the same-colored light. The pillar 155 may be formed of the same material as or a different material from the pixel defining layer 150. More specifically, the pillar 155 may be a photosensitive resin. Further, the pillar 155 may be formed of one selected from the group consisting of an acrylic-based organic material, a polyimide-based organic material, and a polyphenolic-based organic material.

[0022] The pillar 155 and the pixel defining layer 150 having the opening 150a may be formed at the same time using a halftone mask. More specifically, a single or double insulating layer for forming the pixel defining layer 150 and the pillar 155 is stacked on the pixel electrode 140. By using the halftone mask, while the opening 150a is being formed in the pixel defining layer 150, the pillar 155 is formed at the same time.

[0023] Thereafter, a first charge injection/transport layer 143 may be formed on the substrate 100 having the pillar 155. The first charge injection/transport layer 143 may be a single layer or a multilayer charge injection/transport layer. When the pixel electrode 140 is an anode, the first charge injection/transport layer 143 is a hole injection/transport layer. When the pixel electrode 140 is a cathode, the first charge injection/transport layer 143 is an electron injection/transport layer.

[0024] Thereafter, a fine metal mask 900 may be adhered to the substrate 100 such that it has a slit exposing the red unit pixel region R. In one embodiment, the fine metal mask 900 may be adhered to the first charge injection/transport layer 143 formed on the pillar 155. Alternatively, if the first charge injection/transport layer 143 is not formed, the fine metal mask 900 may be adhered to the pillar 155. That is, the fine metal mask 900 may be supported by the pillar 155. Since the pillar 155 is formed between the emission regions of the adjacent unit pixel regions that emit the same-colored light, the pillar 155 is exposed by the slit or covered by the fine metal mask 900 so that it is not in contact with an edge 900s of the slit. Accordingly, the edge 900s of the slit is located a predetermined distance from the first charge injection/transport layer 143 above the substrate 100. Alternatively, if the first charge injection/transport layer 143 is not formed, the edge 900s of the slit is located a predetermined distance above the pixel defining layer 150.

[0025] Subsequently, a red emission layer 145R may be formed on the substrate 100 using the fine metal mask 900 as a mask. The red emission layer 145R may be formed on the first charge injection/transport layer 143 in the red unit pixel region R. After that, the fine metal

mask 900 may be removed from the substrate 100. As described above, because the edge 900s of the slit is located a predetermined distance above the first charge injection/transport layer 143 or the pixel defining layer 150 due to the pillar 155, cracks may not form in the first charge injection/transport layer 143 or the pixel defining layer 150 during the removal of the fine metal mask 900.

[0026] The pillar 155 is formed to a height of 1 μm such that the edge 900s of the slit can be spaced a sufficient distance apart from the first charge injection/transport layer 143 or the pixel defining layer 150. However, when the pillar 155 has an excessive height, a shadow effect may take place. Accordingly, the pillar 155 may be formed to a height of about 1 μm . Also, the pillar 155 may have a width 155w smaller than a width Pw of the red unit pixel region R. More preferably, the width 155w of the pillar 155 is equal to or smaller than a width Ew of the emission region E. Hence, close adhesion of the edge 900s of the slit to the pillar 155 or the first charge injection/transport layer 143 formed on the pillar 155 can be effectively prevented.

[0027] Referring to FIG. 3B, FIG. 4B, FIG. 5B, FIG. 6B, and FIG. 7B, a green emission layer 145G and a blue emission layer 145B are formed in the green and blue unit pixel regions, respectively, in the same manner as when the red emission layer 145R is formed. As described above, the pillar 155 prevents edges of slits of fine metal masks used to form the green and blue emission layers 145G and 145B from being adhered to the first charge injection/transport layer 143 formed on the pixel defining layer 150 or the pixel defining layer 150. Thus, when the fine metal masks are removed, (a crack) or cracks may not form in the first charge injection/transport layer 143 formed on the pixel defining layer 150 or in the pixel defining layer 150.

[0028] A second charge injection/transport layer 147 may be formed on the red, green, and blue emission layers 145R, 145G, and 145B. The second charge injection/transport layer 147 may be formed using a spin coating process or a blanket deposition process. The second charge injection/transport layer 147 may be a single layer or a multiple layer of a second charge injection layer and a second charge transport layer. When the pixel electrode 140 is an anode, the second charge injection/transport layer 147 is an electron injection/transport layer. When the pixel electrode 140 is a cathode, the second charge injection/transport layer 147 is a hole injection/transport layer.

[0029] An opposite electrode 149 is formed on the second charge injection/transport layer 147. When the pixel electrode 140 is an anode, the opposite electrode 149 is formed as a cathode, whereas when the pixel electrode 140 is a cathode, the opposite electrode 149 is formed as an anode. As stated above, the present invention may prevent formation of cracks in an organic layer adjacent to the emission region E (*i.e.*, in the first charge injection/transport layer 143 formed on the pixel defining layer 150 or the pixel defining layer 150) that may be caused

by removal of the fine metal mask 900. As a result, the cathode may be applied uniformly, without having portions thereof thinned or separated by a crack. The uniform application of the cathode suppresses and/or eliminates the pixel reduction phenomenon, and increases the amount of light emitted from an edge portion of the unit pixel region.

[0030] Hereinafter, a method of fabricating an OLED according to another embodiment of the present invention is described with reference to FIG. 3A, FIG. 3B, FIG. 8A, FIG. 8B, FIG. 9A, FIG. 9B, FIG. 10A, FIG. 10B, FIG. 11A, and FIG. 11B. Specifically, FIG. 8A and FIG. 8B are cross-sectional views taken along lines II-II of FIG. 3A and FIG. 3B, respectively. FIG. 9A and FIG. 9B are cross-sectional views taken along lines III-III of FIG. 3A and FIG. 3B, respectively. FIG. 10A and FIG. 10B are cross-sectional views taken along lines IV-IV of FIG. 3A and FIG. 3B, respectively. FIG. 11A and FIG. 11B are cross-sectional views taken along lines V-V of FIG. 3A and FIG. 3B, respectively.

[0031] Referring to FIG. 3A, FIG. 8A, FIG. 9A, FIG. 10A, and FIG. 11A, a substrate 100 on which red, green, and blue unit pixel regions R, G, and B are arranged is provided. The red, green, and blue unit pixel regions may be arranged in a stripe shape. That is, regions that emit same-colored light may be arranged in a column or row. Each of the unit pixel regions R, G, and B includes an emission region E and a non-emission region, which corresponds to a region excluding the emission region E.

[0032] The substrate 100 may be a glass substrate, a plastic substrate, or a quartz substrate. A buffer layer 105, a TFT, and an interlayer insulating layer 125 may be formed on the substrate 100 in the same manner TFT completed after 125 as described with reference to FIG. 4A, FIG. 5A, FIG. 6A, and FIG. 7A. The TFT may include a semiconductor layer 110, a gate insulating layer 115, a gate electrode 120, and source and drain electrodes 130a and 130b, and the semiconductor layer 110 includes source and drain regions 110a and 110b and a channel region 110c. As mentioned above, a capacitor (not shown) may be formed in the non-emission region during the formation of the TFT.

[0033] A passivation insulating layer 135 may be formed on the source and drain electrodes 130a and 130b. The passivation insulating layer 135 may be an organic layer, an inorganic layer, or a combination thereof. A pixel electrode 140 may be formed on the passivation insulating layer 135 to contact one of the source and drain electrodes 130a and 130b through a via hole. Unlike the embodiments described above, a region occupied by the pixel electrode 140 may correspond to the emission region E. That is, the emission region E may be defined by the pixel electrode 140. Meanwhile, a pixel driving circuit, which is electrically connected to the pixel electrode 140, may be disposed in the non-emission region. The pixel driving circuit may include the above-described TFT and capacitor.

[0034] The pixel electrode 140 may be formed as an

anode or a cathode. When the pixel electrode 140 is formed as the anode, it may be made of ITO or IZO. Before the pixel electrode 140 as the anode is formed, a reflective layer may be formed on the passivation insulating layer 135 using one selected from the group consisting of Al, Ag, MoW, AlNd, and Ti. On the other hand, the pixel electrode 140 as the cathode may be made of Mg, Ca, Al, Ag, Ba, or an alloy thereof.

[0035] A pillar 155 may be formed on the substrate 100 on which the pixel electrode 140 is formed such that it protrudes upward further than the pixel electrode 140. The pillar 155 may be formed between emission regions of adjacent unit pixel regions that emit same-colored light. Also, the pillar 155 may have a length 155L equal to or smaller than a distance Ed between the emission regions of the adjacent unit pixel regions that emit the same-colored light. The pillar 155 may be a photosensitive resin. Further, the pillar 155 may be formed of one selected from the group consisting of an acrylic-based organic material, a polyimide-based organic material, and a polyphenolic-based organic material.

[0036] Thereafter, a first charge injection/transport layer 143 may be formed on the substrate 100 having the pillar 155. The first charge injection/transport layer 143 may be a single layer or a multilayer charge injection/transport layer. When the pixel electrode 140 is an anode, the first charge injection/transport layer 143 is a hole injection/transport layer. When the pixel electrode 140 is a cathode, the first charge injection/transport layer 143 is an electron injection/transport layer.

[0037] Thereafter, a fine metal mask 900 may be adhered to the substrate 100 such that a slit in the mask exposes the red unit pixel region R. In such an embodiment, the fine metal mask 900 may be adhered to the first charge injection/transport layer 143 formed on the pillar 155. If the first charge injection/transport layer 143 is not formed, the fine metal mask 900 may be adhered to the pillar 155. That is, the fine metal mask 900 may be supported by the pillar 155. Since the pillar 155 is formed between the emission regions of the adjacent unit pixel regions that emit the same-colored light, the pillar 155 is exposed by the slit or covered by the fine metal mask 900 so that it is not in contact with an edge 900s of the slit. Accordingly, the edge 900s of the slit is located a predetermined distance from the first charge injection/transport layer 143 above the substrate 100.

[0038] Subsequently, a red emission layer 145R may be formed on the substrate 100 using the fine metal mask 900 as a mask. The red emission layer 145R may be formed on the first charge injection/transport layer 143 in the red emission region R. After that, the fine metal mask 900 is removed from the substrate 100. As stated above, because the edge 900s of the slit is located a predetermined distance from the first charge injection/transport layer 143 due to the pillar 155, cracks may not form in the first charge injection/transport layer 143 during the removal of the fine metal mask 900.

[0039] The pillar 155 is formed to a height of 1 μm such

that the edge 900s of the slit can be spaced a sufficient distance apart from the first charge injection/transport layer 143. However, when the pillar 155 has an excessive height, a shadow effect may take place. Accordingly, the pillar 155 is formed to a height of about 1 μm . Also, the pillar 155 may have a width 155w smaller than a width Pw of the red unit pixel region R. More preferably, the width 155w of the pillar 155 is equal to or smaller than a width Ew of the emission region E. Hence, close adhesion of the edge 900s of the slit to the pillar 155 or the first charge injection/transport layer 143 formed on the pillar 155 can be effectively prevented.

[0040] Referring to FIG. 3B, FIG. 8B, FIG. 9B, FIG. 10B, and FIG. 11B, a green emission layer 145G and a blue emission layer 145B are formed in the green and blue unit pixel regions, respectively, in the same manner as when the red emission layer 145R is formed. As described above, the pillar 155 prevents edges of slits of fine metal masks used to form the green and blue emission layers 145G and 145B from adhering to the first charge injection/transport layer 143. Thus, when the fine metal masks are removed, cracks may not form in the first charge injection/transport layer 143.

[0041] A second charge injection/transport layer 147 may be formed on the red, green, and blue emission layers 145R, 145G, and 145B. The second charge injection/transport layer 147 may be formed using a spin coating process or a blanket deposition process. The second charge injection/transport layer 147 may be a single layer or multi-layer second charge injection/transport layer. When the pixel electrode 140 is an anode, the second charge injection/transport layer 147 is an electron injection/transport layer. When the pixel electrode 140 is a cathode, the second charge injection/transport layer 147 is a hole injection/transport layer.

[0042] An opposite electrode 149 is formed on the second charge injection/transport layer 147. When the pixel electrode 140 is an anode, the opposite electrode 149 is formed as a cathode, whereas when the pixel electrode 140 is a cathode, the opposite electrode 149 is formed as an anode. As stated above, the present invention may prevent formation of cracks in an organic layer adjacent to the emission region E (*i.e.*, in the first charge injection/transport layer 13) that may be caused by removal of the fine metal mask 900. Consequently, the cathode may be uniformly deposited. Uniform application of the cathode suppresses and/or eliminates the pixel reduction phenomenon, and increases the amount of light emitted from an edge portion of the unit pixel region.

[0043] As explained thus above, the present invention may prevent formation of cracks in an organic layer adjacent to an emission region caused by removal of a fine metal mask, so that a cathode is not thinned or cut by the crack. Hence, an OLED device manufactured according to the principles of the invention can operate with improved viewing contrast and/or picture quality.

Claims

1. An organic light emitting display device, comprising:
 - unit pixel regions arranged on a substrate (100),
 - each of the unit pixel regions including an emission region (E) and a non-emission region;
 - a pixel electrode (140) disposed at least in the emission region (E);
 - a pillar (155) disposed between emission regions (E) of adjacent unit pixel regions that emit same-colored light, the pillar (155) protruding upward further than the pixel electrode (140);
 - an emission layer (145R) disposed on the pixel electrode (140); and
 - an opposite electrode (149) disposed on the emission layer (145R),

wherein the width (155w) of the pillar (155) is equal to or smaller than a width (Ew) of the emission region (E), and **characterized in that** the unit pixel regions including red unit pixel regions (R), green unit pixel regions (G), and blue unit pixel regions (B) being arranged in a matrix shape, the matrix comprising row of unit pixel regions of alternating colors (R, G, B) and columns of unit pixel regions of the same color, and **in that** the pillar (155) has a height of 1 μm .
2. The device of claim 1, wherein the pillar (155) has a width (155w) smaller than a width of each of the unit pixel regions.
3. The device of claim 1, wherein the pillar (155) has a length equal to or smaller than a distance between the emission regions (E) of the adjacent unit pixel regions that emit same-colored light.
4. The device of claim 1, wherein the pillar (155) is formed of a material selected from the group consisting of an acrylic-based organic material, a polyimide-based organic material, and a polyphenolic-based organic material.
5. The device of claim 1, wherein the emission region (E) is defined by the pixel electrode (140).
6. The device of claim 1, further comprising a pixel defining layer (150) disposed on the pixel electrode (140) and having an opening that exposes a portion of the pixel electrode (140), wherein the emission region (E) is defined by the opening.
7. The device of claim 6, wherein the pillar (155) is disposed on the pixel defining layer (150).
8. The device of claim 1, wherein the unit pixel regions include red unit pixel regions, green unit pixel regions, and blue unit pixel regions.
9. The device of claim 1, wherein the unit pixel regions are arranged on the substrate (100) in a stripe shape.
10. The device of claim 1, further comprising a pixel driving circuit disposed in the non-emission region and electrically connected to the pixel electrode (140).
11. The device of claim 10, wherein the pixel driving circuit includes a thin film transistor.
12. A method of fabricating an organic light emitting display device, comprising:
 - providing a substrate (100) including unit pixel regions, the unit pixel regions including red unit pixel regions (R), green unit pixel regions (G), and blue unit pixel regions (B) being arranged in a matrix shape, the matrix comprising row of unit pixel regions of alternating colors (R, G, B) and columns of unit pixel regions of the same color, each of the unit pixel regions including an emission region (E) and a non-emission region;
 - forming a pixel electrode (140) on the substrate (100) in the emission region (E);
 - forming a pillar (155) between emission regions (E) of adjacent unit pixel regions that emit same-colored light; wherein the width (155w) of the pillar (155) is equal to or smaller than a width (Ew) of the emission region (E), and wherein the pillar (155) has a height of 1 μm ;
 - closely adhering a fine metal mask (900) to the substrate (100) having the pillar (155), the fine metal mask (900) having a slit that exposes the adjacent unit pixel regions that emit same-colored light; and
 - forming an emission layer (145R) on the exposed unit pixel regions.
13. The method of claim 12, wherein the pillar (155) is formed to have a width (155w) smaller than a width of each of the unit pixel regions and a length equal to or smaller than a distance between the emission regions (E) of the adjacent unit pixel regions that emit same-colored light.
14. The method of claim 12, wherein a region where the pixel electrode (140) is formed corresponds to the emission region (E).
15. The method of claim 12, further comprising forming a pixel defining layer (150) on the pixel electrode (140), the pixel defining layer (150) having an opening that exposes a portion of the pixel electrode (140), wherein a region where the opening is formed corresponds to the emission region (E), and the pillar

(155) is formed on the pixel defining layer (150).

16. The method of claim 15, wherein the pillar (155) and the pixel defining layer (150) having the opening are formed simultaneously using a halftone mask.

Patentansprüche

1. Organische lichtemittierende Anzeigevorrichtung, umfassend:

Einheitspixelbereiche, die auf einem Substrat (100) angeordnet sind, wobei jeder der Einheitspixelbereiche einen Emissionsbereich (E) und einen Nichtemissionsbereich umfasst; eine Pixelelektrode (140), die wenigstens in dem Emissionsbereich (E) angeordnet ist; eine Säule (155), die zwischen Emissionsbereichen (E) benachbarter Einheitspixelbereiche, die gleichfarbiges Licht emittieren, angeordnet ist, wobei die Säule (155) weiter nach oben ragt als die Pixelelektrode (140); eine Emissionsschicht (145R), die auf der Pixelelektrode (140) angeordnet ist; und eine gegenüberliegende Elektrode (149), die auf der Emissionsschicht (145R) angeordnet ist,

wobei die Breite (155w) der Säule (155) gleich oder kleiner als eine(r) Breite (Ew) des Emissionsbereichs (E) ist, und **dadurch gekennzeichnet, dass** die Einheitspixelbereiche, die rote Einheitspixelbereiche (R), grüne Einheitspixelbereiche (G) und blaue Einheitspixelbereiche (B) umfassen, in einer Matrixform angeordnet sind, wobei die Matrix eine Reihe von Einheitspixelbereichen abwechselnder Farben (R, G, B) und Spalten von Einheitspixelbereichen der gleichen Farbe umfasst, und dass die Säule (155) eine Höhe von 1 μm aufweist.

2. Vorrichtung nach Anspruch 1, wobei die Säule (155) eine Breite (155w) aufweist, die kleiner ist als eine Breite jedes der Einheitspixelbereiche.
3. Vorrichtung nach Anspruch 1, wobei die Säule (155) eine Länge aufweist, die gleich oder kleiner als ein(em) Abstand zwischen den Emissionsbereichen (E) der benachbarten Einheitspixelbereiche, die gleichfarbiges Licht emittieren, ist.
4. Vorrichtung nach Anspruch 1, wobei die Säule (155) aus einem Material ausgebildet ist, das ausgewählt ist aus der Gruppe bestehend aus einem organischen Material auf Acrylbasis, einem organischen Material auf Polyimidbasis und einem organischen Material auf Polyphenolbasis.
5. Vorrichtung nach Anspruch 1, wobei der Emissions-

bereich (E) durch die Pixelelektrode (140) definiert ist.

6. Vorrichtung nach Anspruch 1, die weiterhin eine Pixeldefinitionsschicht (150) umfasst, die auf der Pixelelektrode (140) angeordnet ist und eine Öffnung aufweist, die einen Abschnitt der Pixelelektrode (140) freilegt, wobei der Emissionsbereich (E) durch die Öffnung definiert ist.
7. Vorrichtung nach Anspruch 6, wobei die Säule (155) auf der Pixeldefinitionsschicht (150) angeordnet ist.
8. Vorrichtung nach Anspruch 1, wobei die Einheitspixelbereiche rote Einheitspixelbereiche, grüne Einheitspixelbereiche und blaue Einheitspixelbereiche umfassen.
9. Vorrichtung nach Anspruch 1, wobei die Einheitspixelbereiche in einer Streifenform auf dem Substrat (100) angeordnet sind.
10. Vorrichtung nach Anspruch 1, die weiterhin eine Pixelansteuerschaltung umfasst, die in dem Nichtemissionsbereich angeordnet und elektrisch mit der Pixelelektrode (140) verbunden ist.
11. Vorrichtung nach Anspruch 10, wobei die Pixelansteuerschaltung einen Dünnschichttransistor umfasst.
12. Verfahren zur Herstellung einer organischen lichtemittierenden Anzeigevorrichtung, umfassend:
- Bereitstellen eines Substrats (100), das Einheitspixelbereiche umfasst, wobei die Einheitspixelbereiche, die rote Einheitspixelbereiche (R), grüne Einheitspixelbereiche (G) und blaue Einheitspixelbereiche (B) umfassen, in einer Matrixform angeordnet sind, wobei die Matrix eine Reihe von Einheitspixelbereichen abwechselnder Farben (R, G, B) und Spalten von Einheitspixelbereichen der gleichen Farbe umfasst, wobei jeder der Einheitspixelbereiche einen Emissionsbereich (E) und einen Nichtemissionsbereich umfasst;
- Ausbilden einer Pixelelektrode (140) auf dem Substrat (100) in dem Emissionsbereich (E);
- Ausbilden einer Säule (155) zwischen Emissionsbereichen (E) benachbarter Einheitspixelbereiche, die gleichfarbiges Licht emittieren; wobei die Breite (155w) der Säule (155) gleich oder kleiner als eine(r) Breite (Ew) des Emissionsbereichs (E) ist und wobei die Säule (155) eine Höhe von 1 μm aufweist;
- anliegendes Kleben einer Feinmetallmaske (900) an das Substrat (100), das die Säule (155)

aufweist, wobei die Feinmetallmaske (900) einen Schlitz aufweist, der die benachbarten Einheitspixelbereiche, die gleichfarbiges Licht emittieren, freilegt; und

Ausbilden einer Emissionsschicht (145R) auf den freiliegenden Einheitspixelbereichen.

13. Verfahren nach Anspruch 12, wobei die Säule (155) so ausgebildet ist, dass sie aufweist: eine Breite (155w), die kleiner ist als eine Breite jedes der Einheitspixelbereiche, und eine Länge, die gleich oder kleiner als ein(em) Abstand zwischen den Emissionsbereichen (E) der benachbarten Einheitspixelbereiche, die gleichfarbiges Licht emittieren, ist.

14. Verfahren nach Anspruch 12, wobei ein Bereich, in dem die Pixelelektrode (140) ausgebildet ist, dem Emissionsbereich (E) entspricht.

15. Verfahren nach Anspruch 12, das weiterhin ein Ausbilden einer Pixeldefinitionsschicht (150) auf der Pixelelektrode (140) umfasst, wobei die Pixeldefinitionsschicht (150) eine Öffnung aufweist, die einen Abschnitt der Pixelelektrode (140) freilegt, wobei ein Bereich, in dem die Öffnung ausgebildet ist, dem Emissionsbereich (E) entspricht und die Säule (155) auf der Pixeldefinitionsschicht (150) ausgebildet ist.

16. Verfahren nach Anspruch 15, wobei die Säule (155) und die Pixeldefinitionsschicht (150), welche die Öffnung aufweist, gleichzeitig unter Verwendung einer Halbtonmaske ausgebildet werden.

Revendications

1. Dispositif d'affichage électroluminescent organique, comprenant :

des régions de pixel unitaire agencées sur un substrat (100), chacune des régions de pixel unitaire comprenant une région d'émission (E) et une région sans émission ;

une électrode de pixel (140) disposée au moins dans la région d'émission (E) ;

un pilier (155) disposé entre les régions d'émission (E) des régions de pixel unitaire adjacentes qui émettent de la lumière de même couleur, le pilier (155) faisant saillie vers le haut plus loin que l'électrode de pixel (140) ;

une couche d'émission (145R) disposée sur l'électrode de pixel (140) ; et

une électrode opposée (149) disposée sur la couche d'émission (145R),

dans lequel la largeur (155w) du pilier (155) est égale ou inférieure à une largeur (Ew) de la région d'émission (E), et **caractérisé en ce que** les régions de pixel unitaire comprenant des régions de pixel unitaire rouges (R), des régions de pixel unitaire vertes (G), et des régions de pixel unitaire bleues (B) qui sont agencées selon une forme de matrice, la matrice comprenant une rangée de régions de pixel unitaire de couleurs alternées (R, G, B) et des colonnes de régions de pixel unitaire de la même couleur, et **en ce que** le pilier (155) a une hauteur de 1 μm .

2. Dispositif selon la revendication 1, dans lequel le pilier (155) a une largeur (155w) inférieure à une largeur de chacune des régions de pixel unitaire.

3. Dispositif selon la revendication 1, dans lequel le pilier (155) a une longueur égale ou inférieure à une distance entre les régions d'émission (E) des régions de pixel unitaire adjacentes qui émettent de la lumière de même couleur.

4. Dispositif selon la revendication 1, dans lequel le pilier (155) est formé avec un matériau choisi dans le groupe comprenant un matériau organique à base d'acrylique, un matériau organique à base de polyimide et un matériau organique à base de polyphénol.

5. Dispositif selon la revendication 1, dans lequel la région d'émission (E) est définie par l'électrode de pixel (140).

6. Dispositif selon la revendication 1, comprenant en outre une couche de définition de pixel (150) disposée sur l'électrode de pixel (140) et ayant une ouverture qui expose une partie de l'électrode de pixel (140), dans lequel la région d'émission (E) est définie par l'ouverture.

7. Dispositif selon la revendication 6, dans lequel le pilier (155) est disposé sur la couche de définition de pixel (150).

8. Dispositif selon la revendication 1, dans lequel les régions de pixel unitaire comprennent des régions de pixel unitaire rouges, des régions de pixel unitaire vertes, et des régions de pixel unitaire bleues.

9. Dispositif selon la revendication 1, dans lequel les régions de pixel unitaire sont agencées sur le substrat (100) selon une forme de bande.

10. Dispositif selon la revendication 1, comprenant en outre un dispositif d'entraînement de pixel disposé dans la région sans émission et électriquement raccordé à l'électrode de pixel (140).

11. Dispositif selon la revendication 10, dans lequel le

circuit d'entraînement de pixel comprend un transistor de film fin.

pillier (155) et la couche de définition de pixel (150) ayant l'ouverture, sont formés simultanément à l'aide d'un masque tramé.

- 12.** Procédé pour fabriquer un dispositif d'affichage électroluminescent organique, comprenant les étapes consistant à :

prévoir un substrat (100) comprenant des régions de pixel unitaire, les régions de pixel unitaire comprenant des régions de pixel unitaire rouges (R), des régions de pixel unitaire vertes (G) et des régions de pixel unitaire bleues (B) comprenant une rangée de régions de pixel unitaire de couleurs alternées (R, G, B) et des colonnes de régions de pixel unitaire de la même couleur, chacune des régions de pixel unitaire comprenant une région d'émission (E) et une région sans émission ;
former une électrode de pixel (140) sur le substrat (100) dans la région d'émission (E) ;
former un pilier (155) entre les régions d'émission (E) des régions de pixel unitaire adjacentes qui émettent de la lumière de même couleur ; dans lequel la largeur (155w) du pilier (155) est égale ou inférieure à une largeur (E_w) de la région d'émission (E), et dans lequel le pilier (155) a une hauteur de $1 \mu\text{m}$;
fixer étroitement un masque métallique fin (900) sur le substrat (100) ayant le pilier (155), le masque métallique fin (900) ayant une fente qui expose les régions de pixel unitaire adjacentes qui émettent de la lumière de la même couleur ; et
former une couche d'émission (145R) sur les régions de pixel unitaire exposées.

- 13.** Procédé selon la revendication 12, dans lequel le pilier (155) est formé pour avoir une largeur (155w) inférieure à une largeur de chacune des régions de pixel unitaire et une longueur égale ou inférieure à une distance entre les régions d'émission (E) des régions de pixel unitaire adjacentes qui émettent de la lumière de la même couleur.

- 14.** Procédé selon la revendication 12, dans lequel une région où l'électrode de pixel (140) est formée correspond à la région d'émission (E).

- 15.** Procédé selon la revendication 12, comprenant en outre l'étape consistant à former une couche de définition de pixel (150) sur l'électrode de pixel (140), la couche de définition de pixel (150) ayant une ouverture qui expose une partie de l'électrode de pixel (140), dans lequel une région où l'ouverture est formée, correspond à la région d'émission (E) et le pilier (155) est formé sur la couche de définition de pixel (150).

- 16.** Procédé selon la revendication 15, dans lequel le

FIG. 1A
(PRIOR ART)

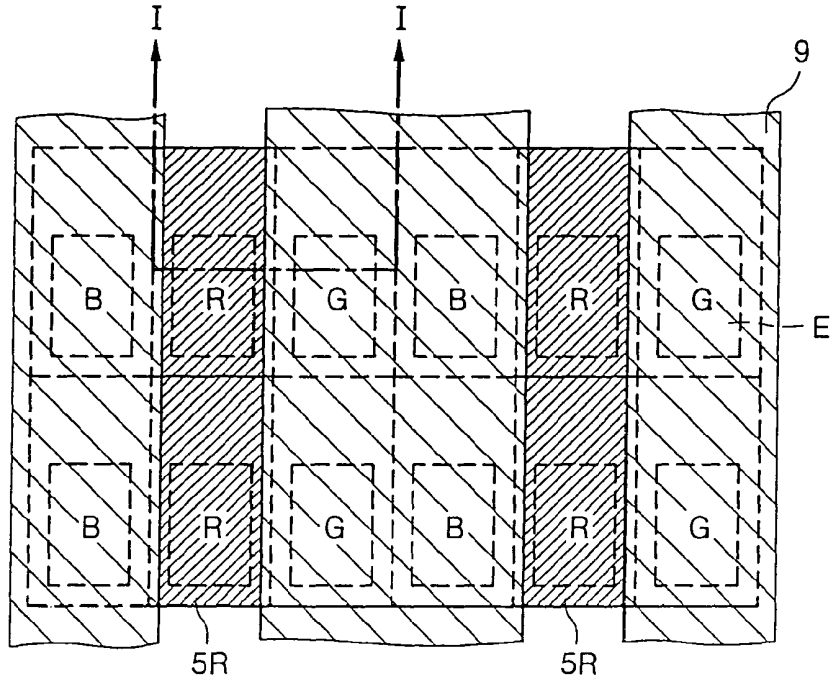

FIG. 1B
(PRIOR ART)

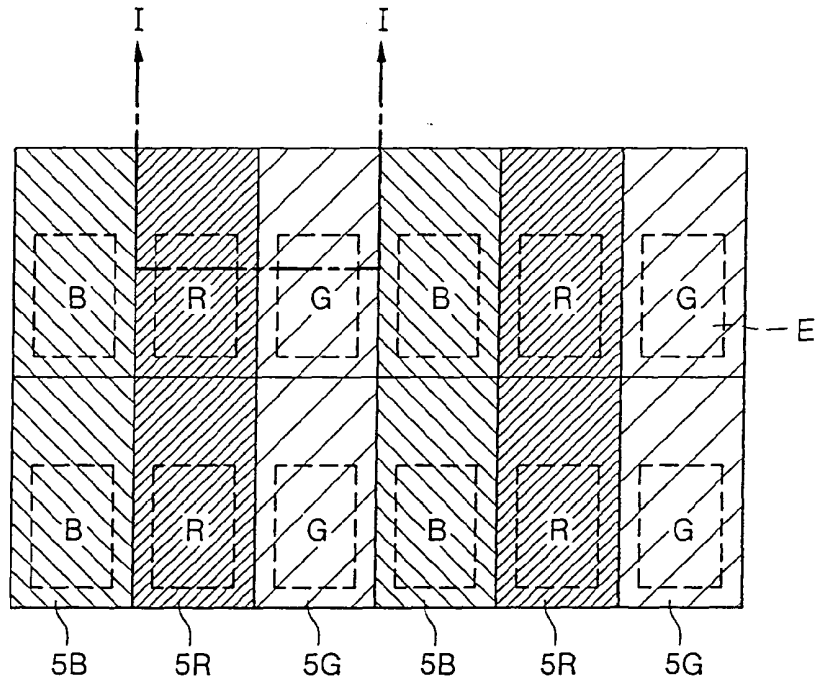

FIG. 2A
(PRIOR ART)

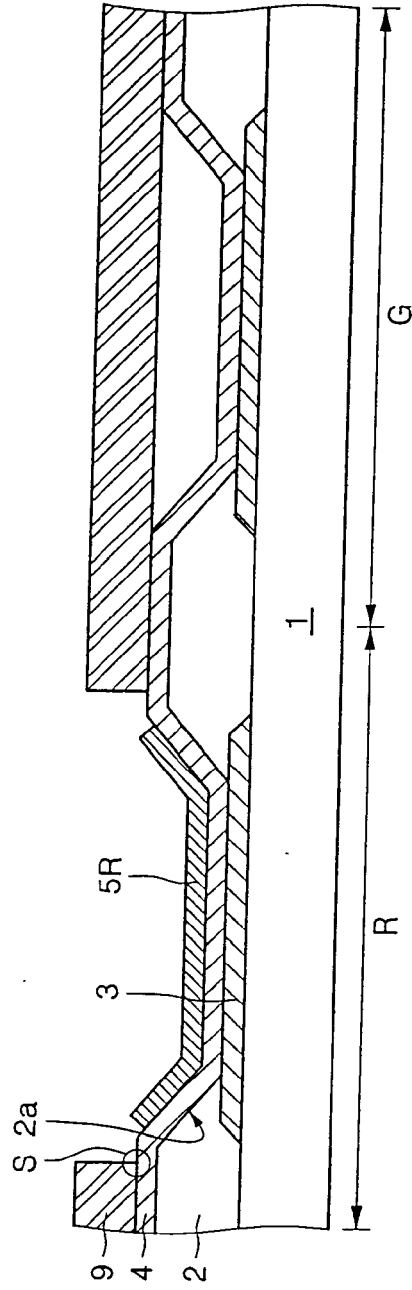

FIG. 2B
(PRIOR ART)

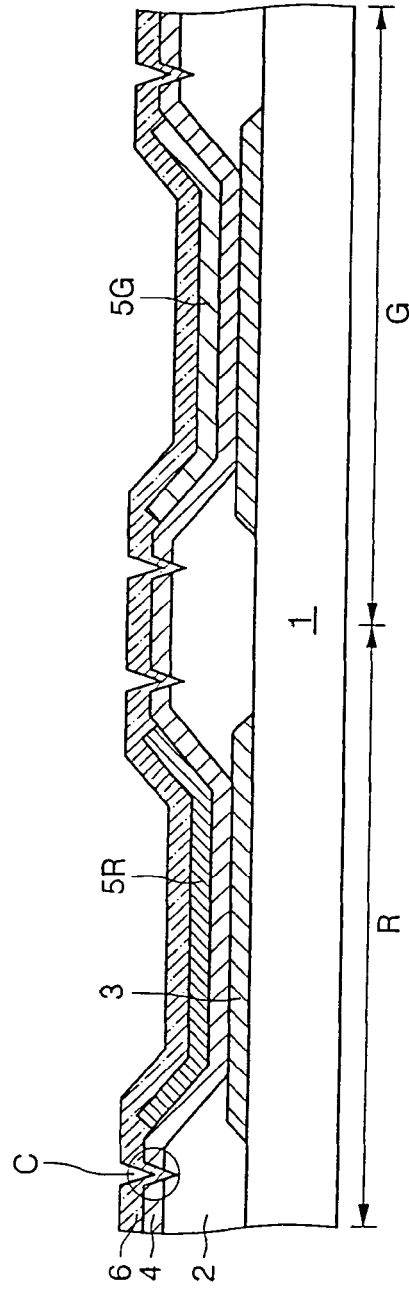

FIG. 3A

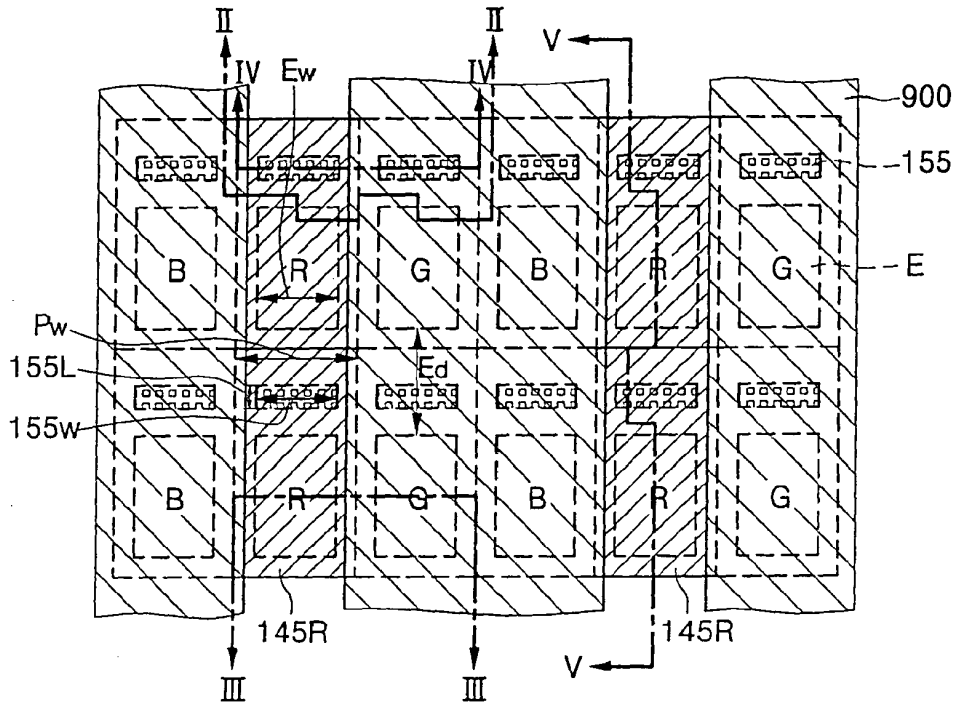

FIG. 3B

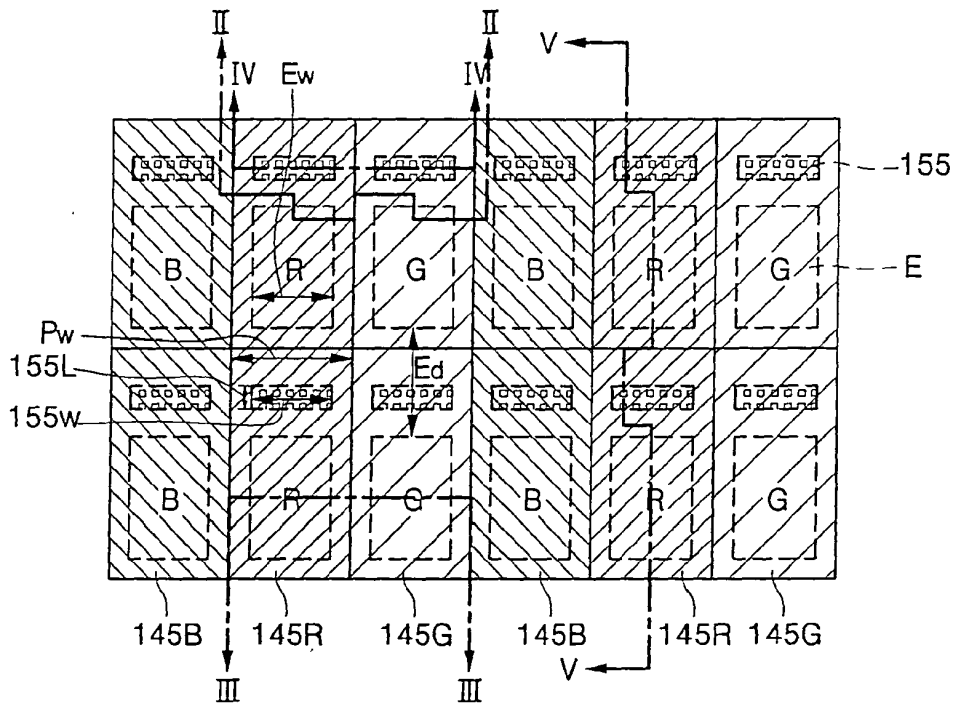

FIG. 4A

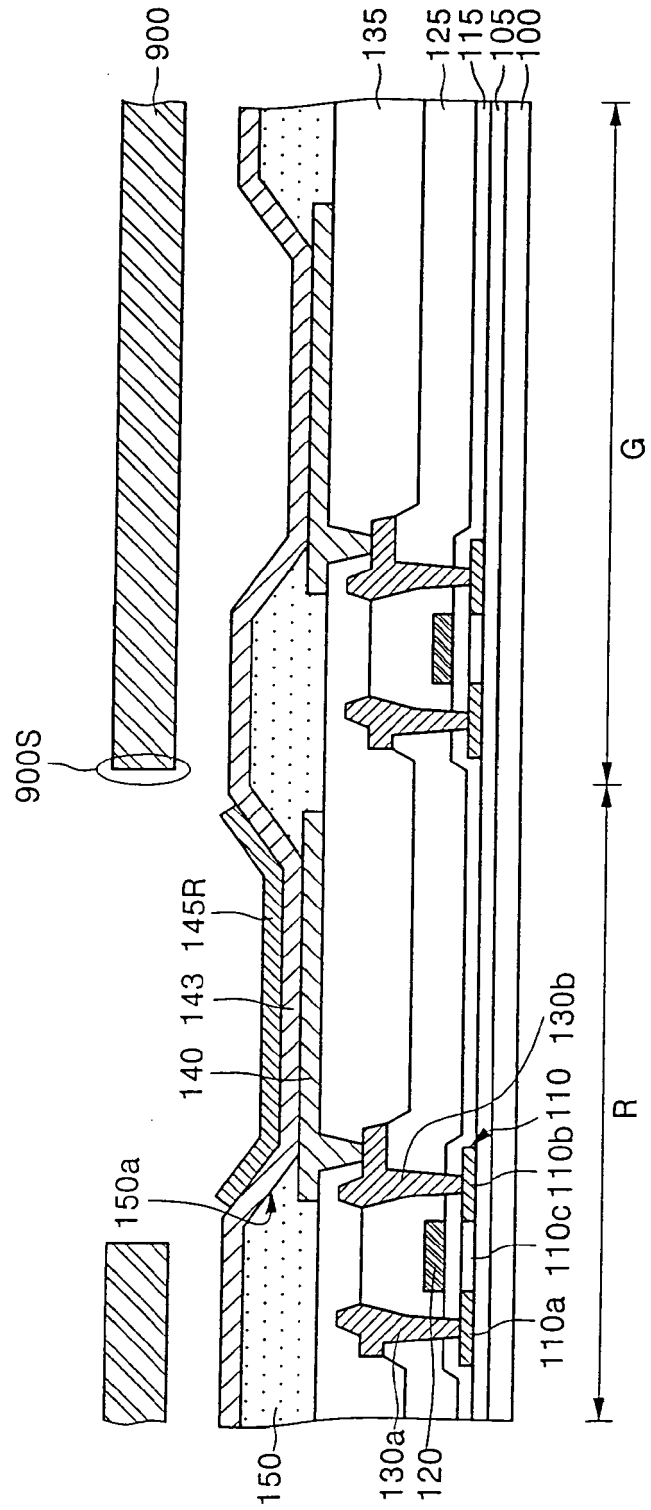

FIG. 4B

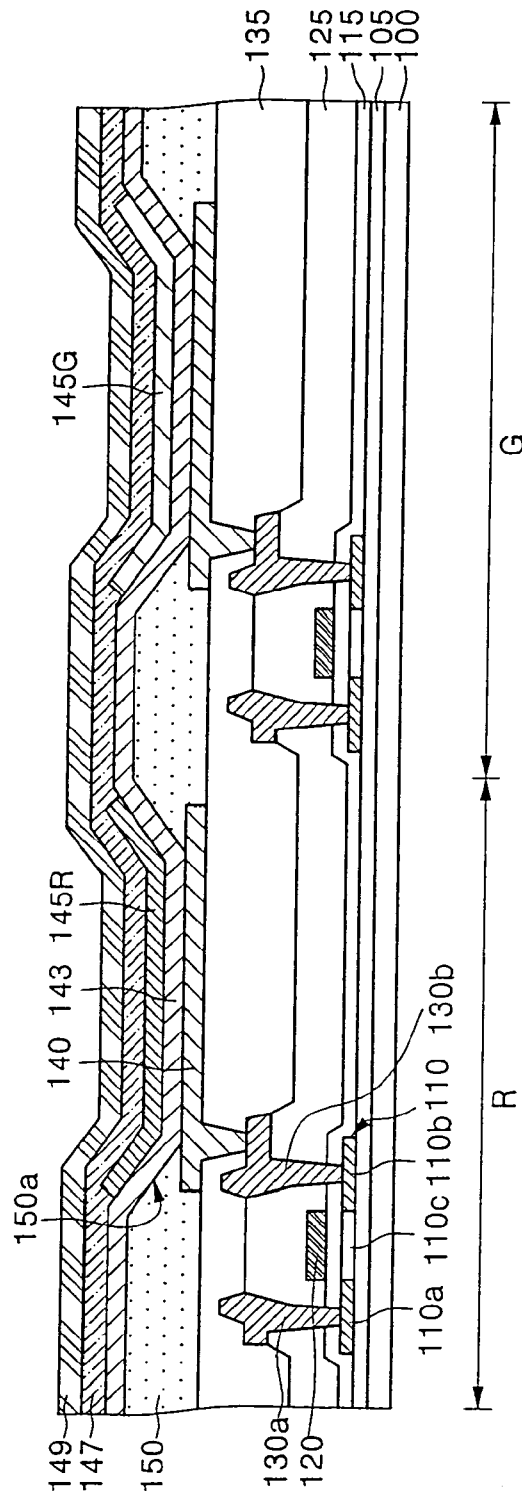

FIG. 5A

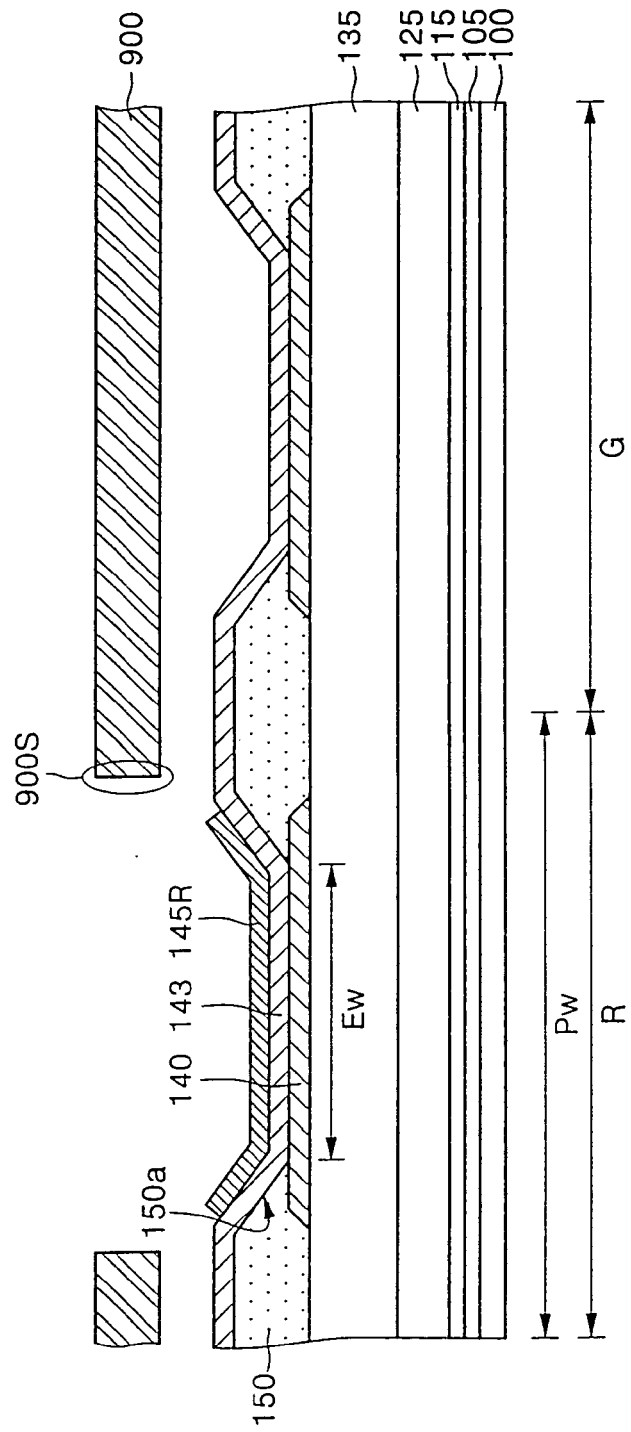

FIG. 5B

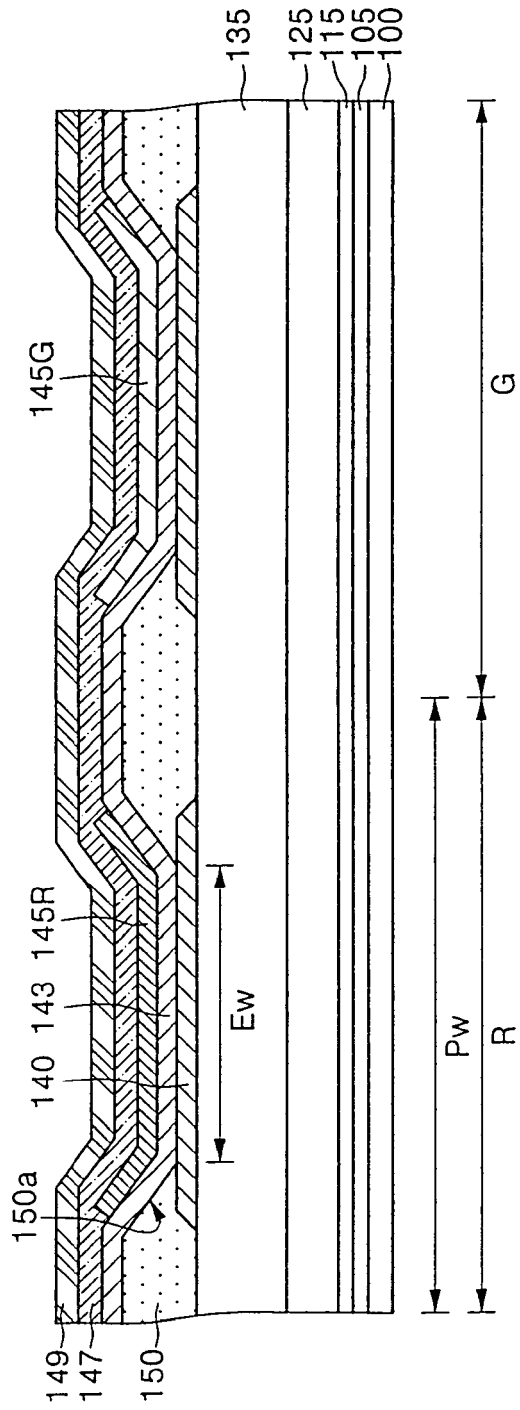

FIG. 6A

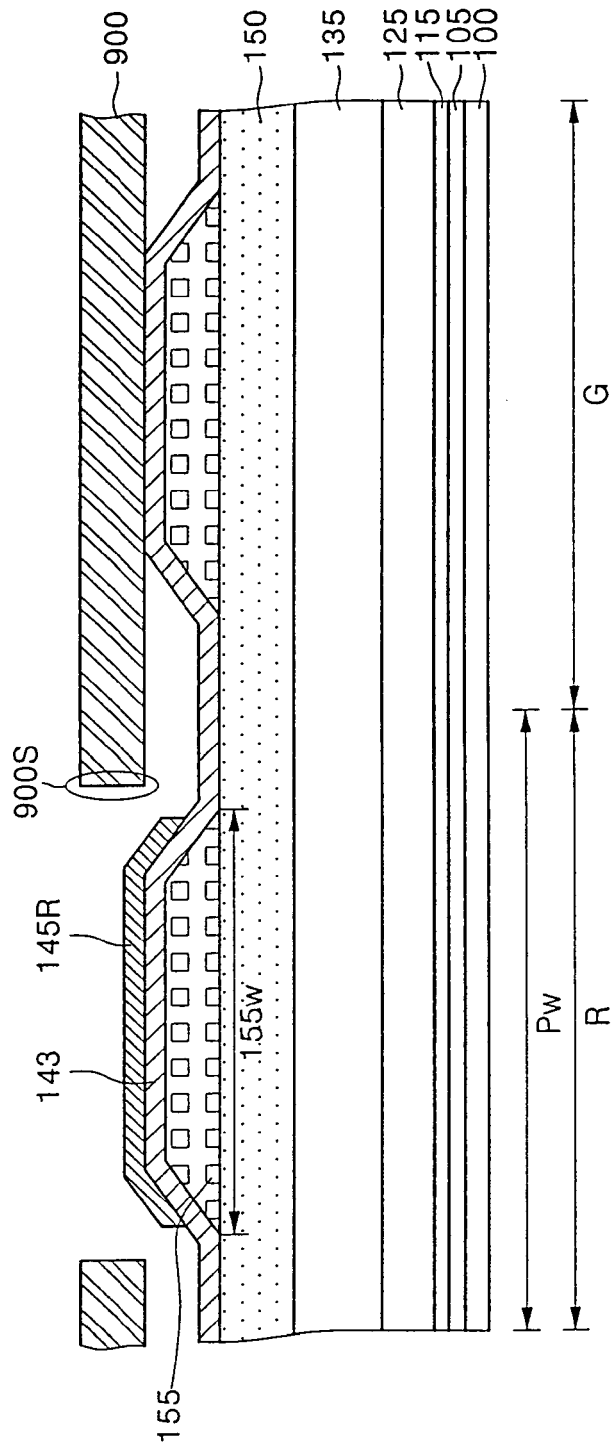

FIG. 6B

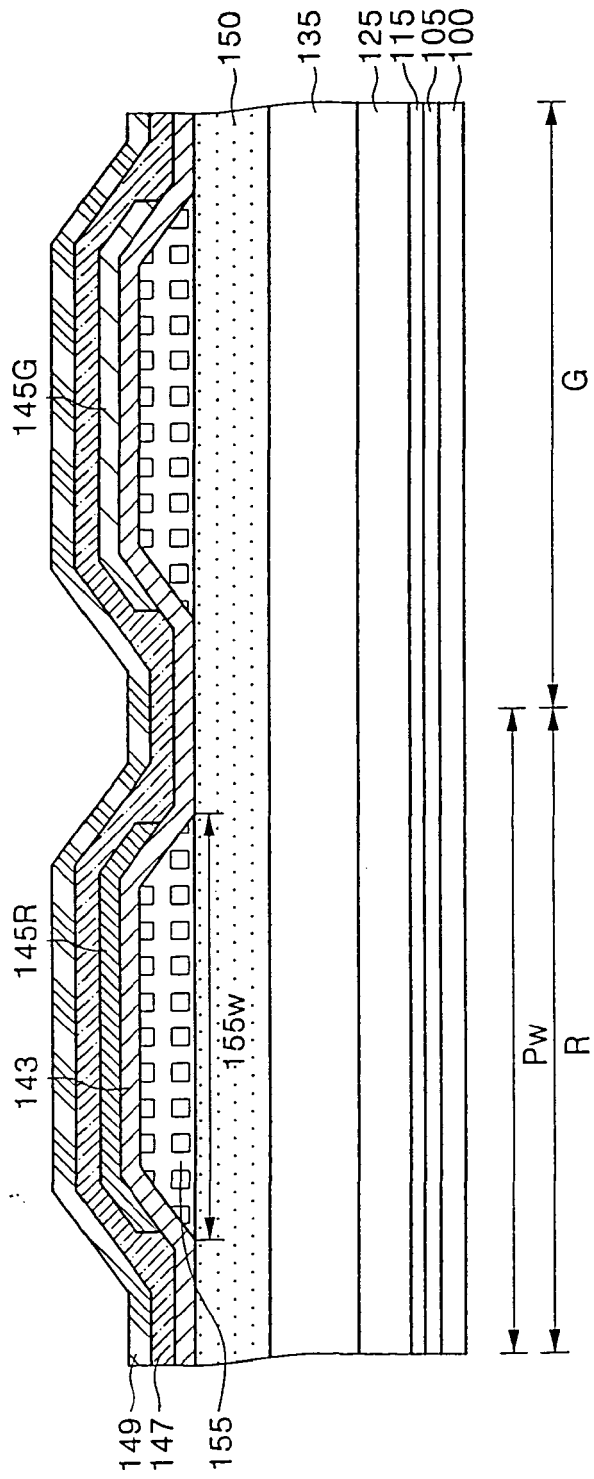

FIG. 7A

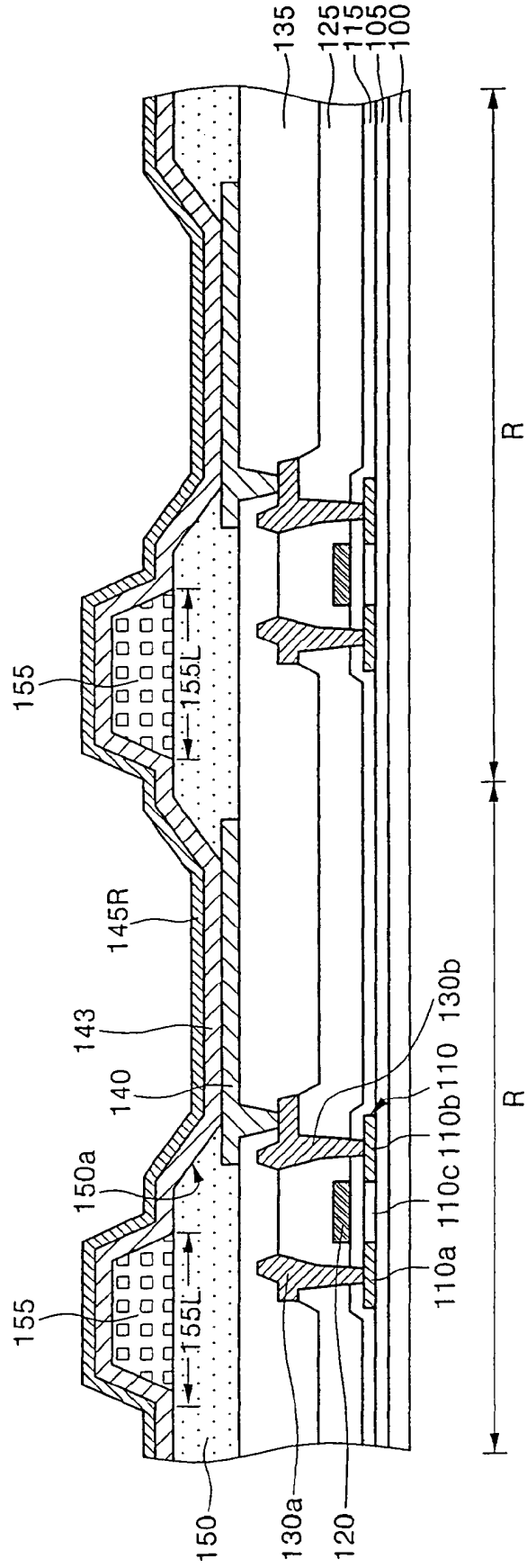

FIG. 7B

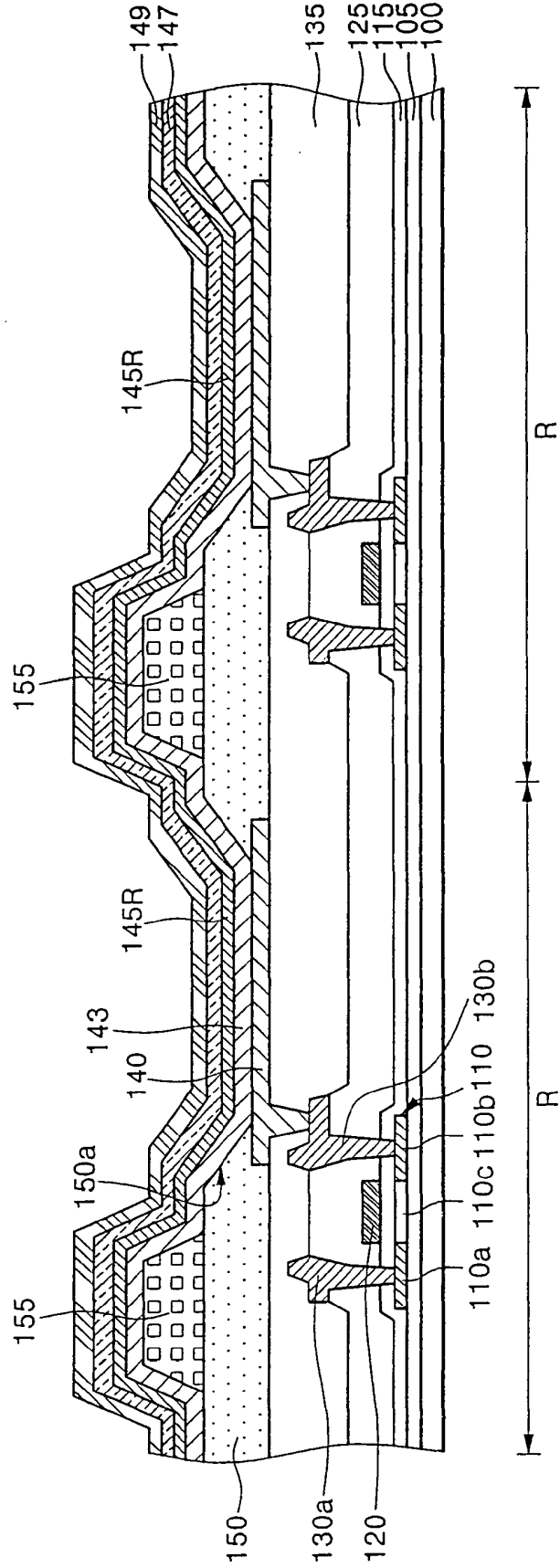

FIG. 8A

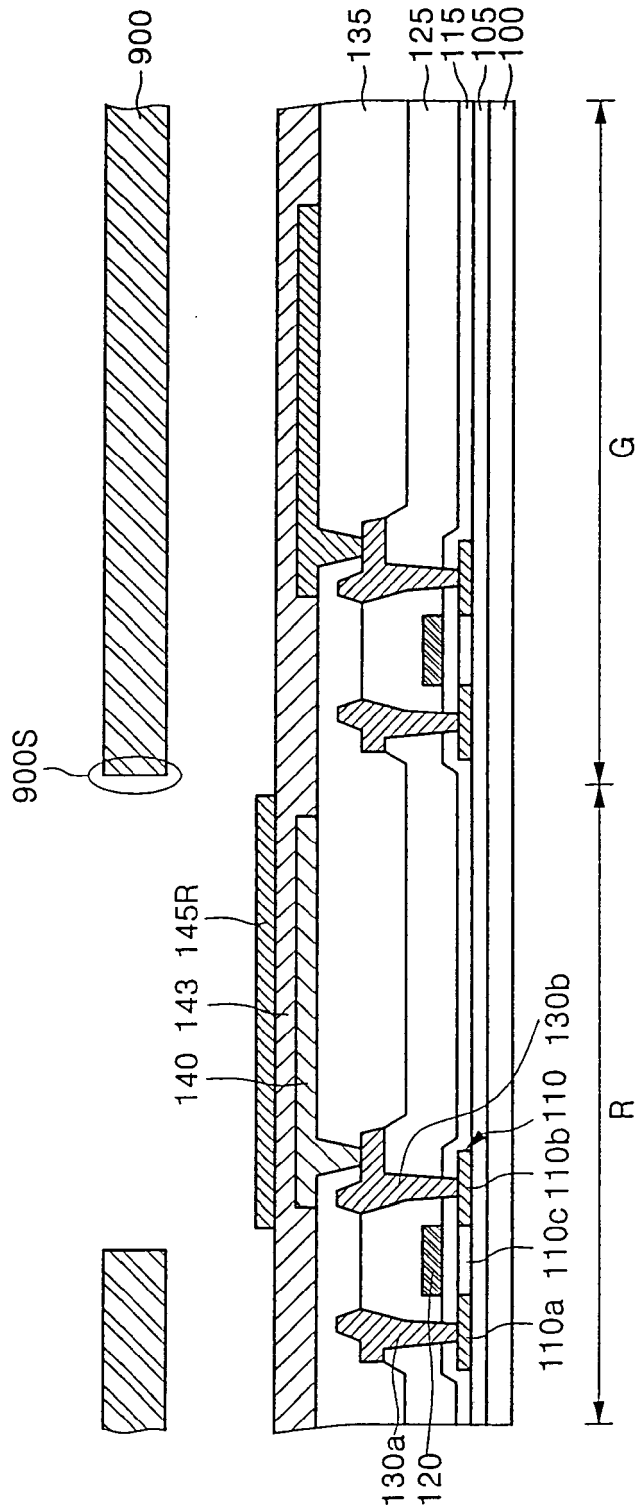

FIG. 8B

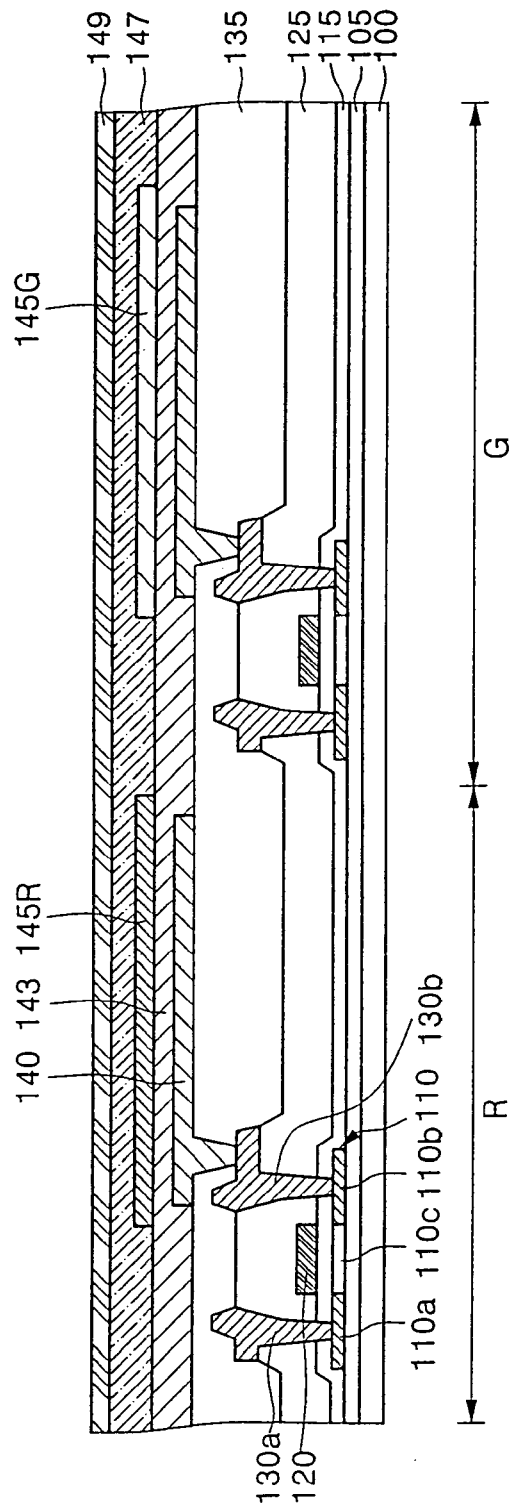

FIG. 9A

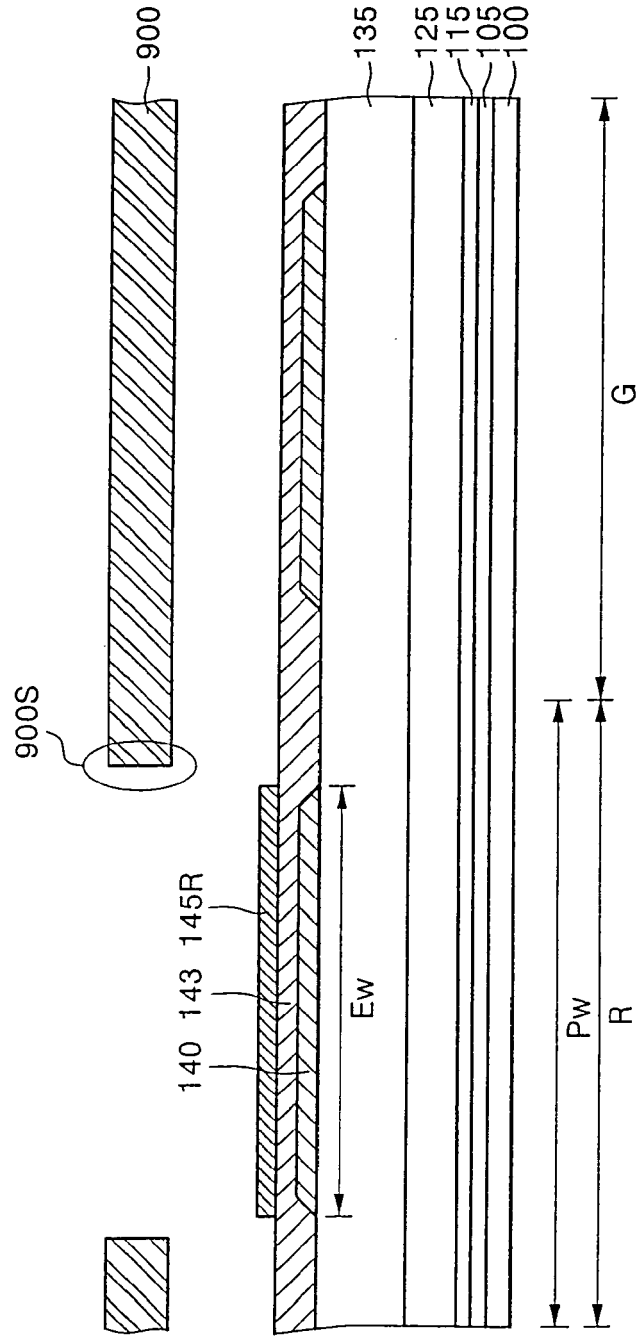

FIG. 9B

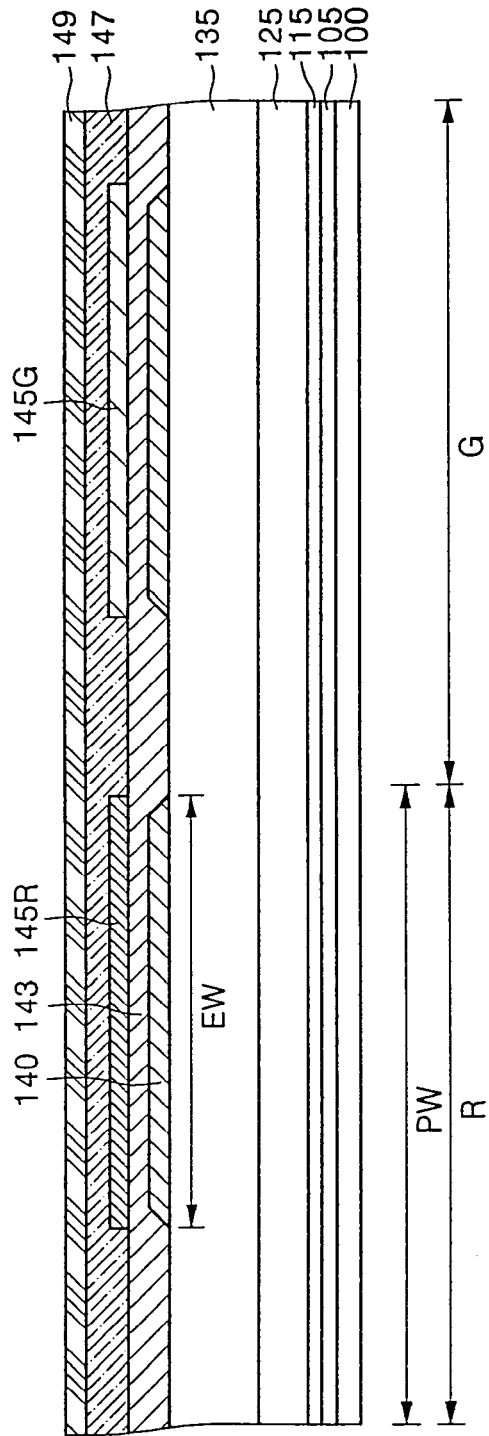

FIG. 10A

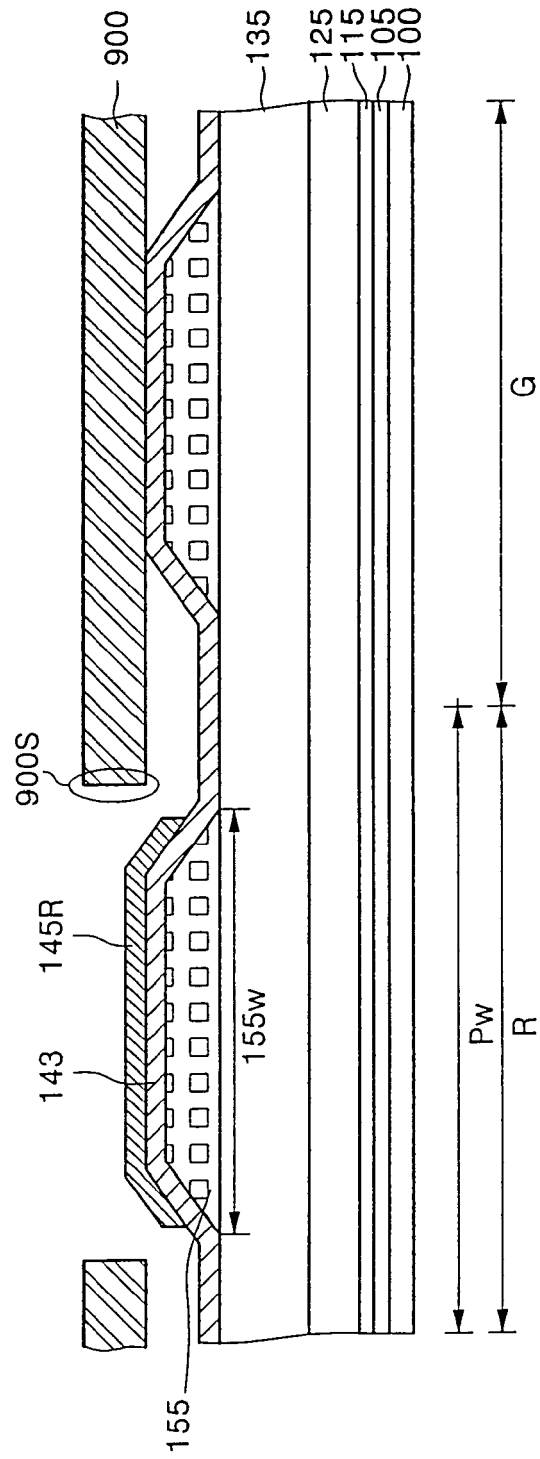

FIG. 10B

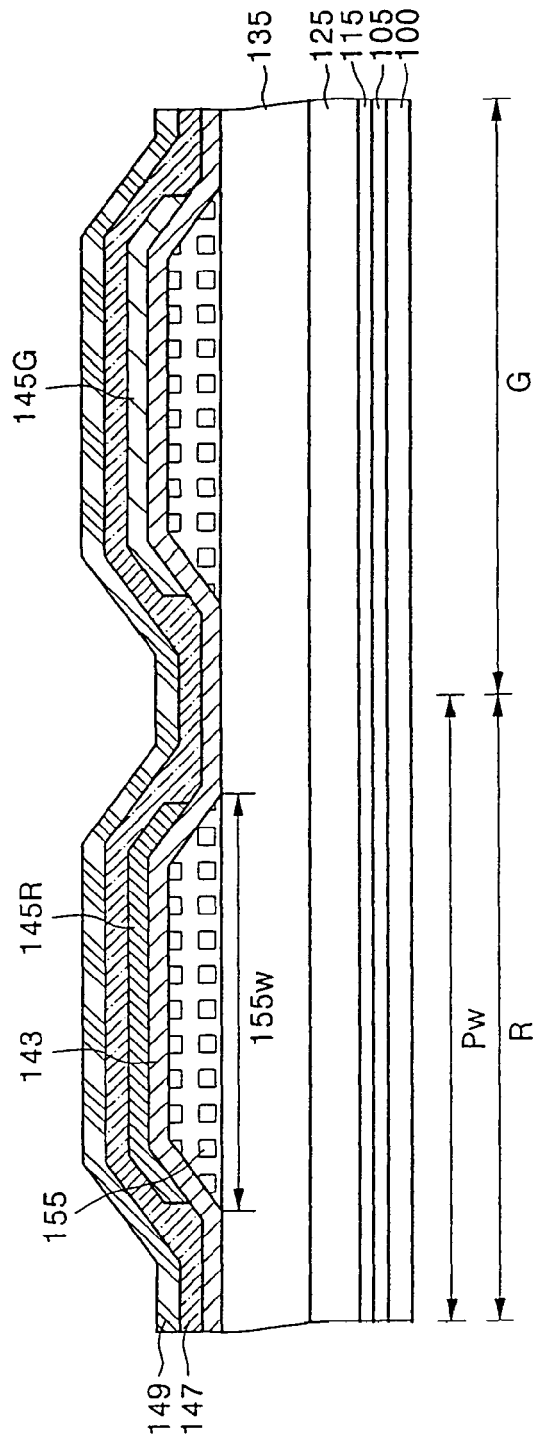

FIG. 11A

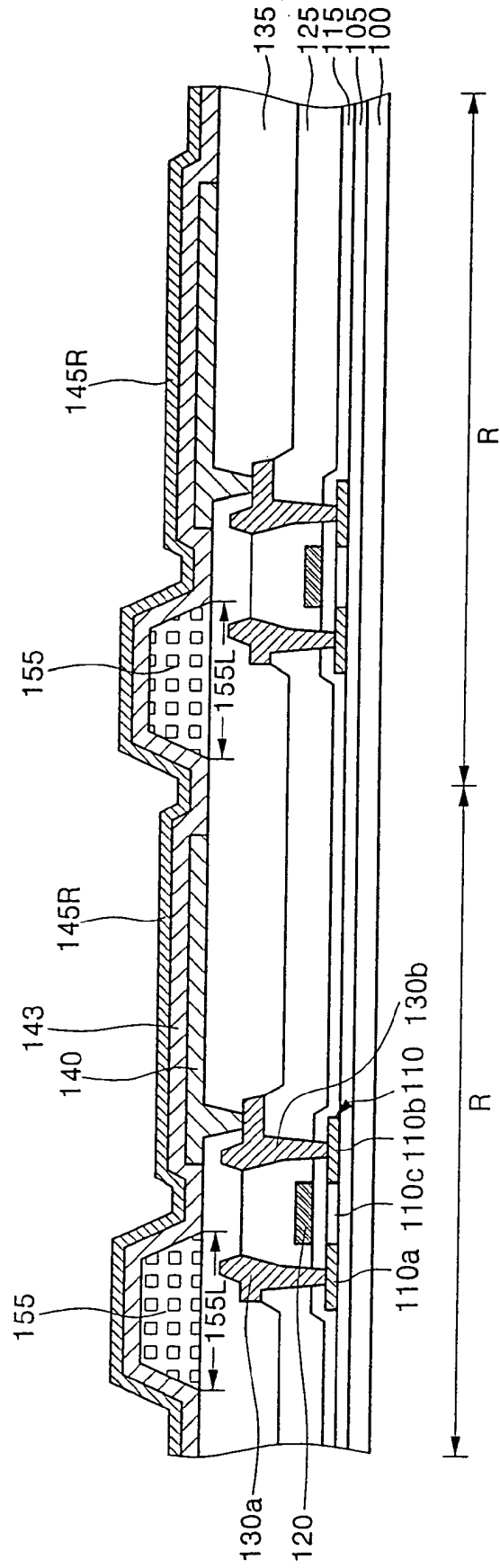
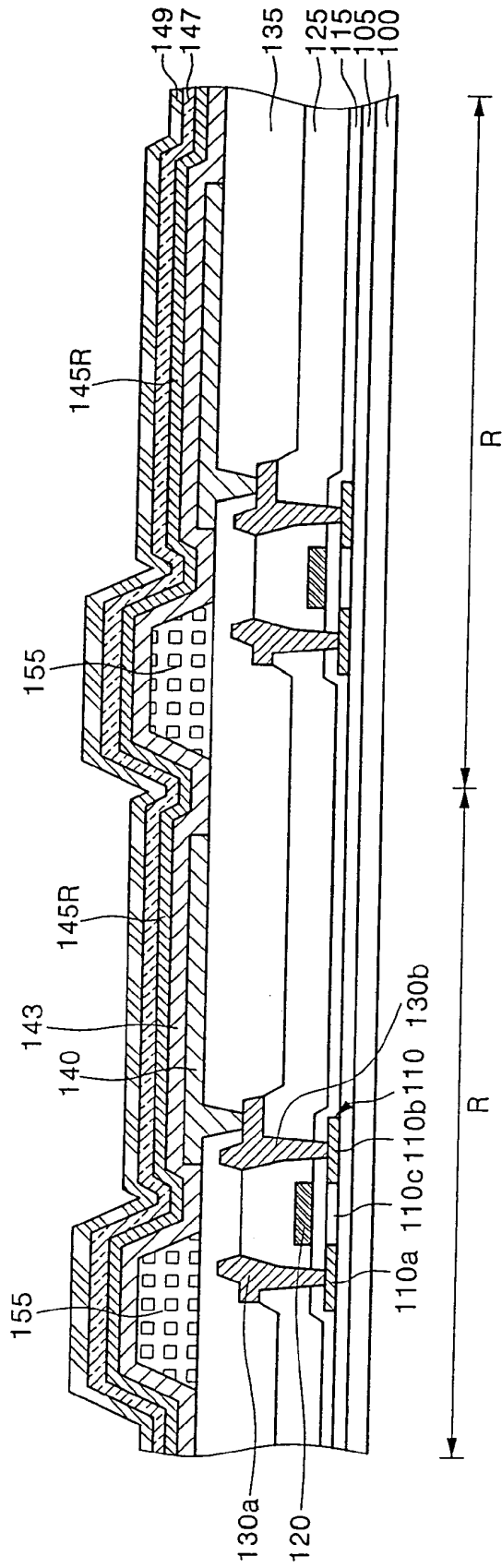

FIG. 11B



REFERENCES CITED IN THE DESCRIPTION

This list of references cited by the applicant is for the reader's convenience only. It does not form part of the European patent document. Even though great care has been taken in compiling the references, errors or omissions cannot be excluded and the EPO disclaims all liability in this regard.

Patent documents cited in the description

- JP 2002151255 A [0002]
- US 2003189400 A1 [0002]
- EP 1096568 A2 [0002]
- KR 20040042844 A [0002]
- US 2004135501 A1 [0002]

专利名称(译)	有机发光显示装置及其制造方法		
公开(公告)号	EP1601033B1	公开(公告)日	2016-10-26
申请号	EP2005104331	申请日	2005-05-23
[标]申请(专利权)人(译)	三星斯笛爱股份有限公司		
申请(专利权)人(译)	三星SDI CO. , LTD.		
当前申请(专利权)人(译)	三星DISPLAY CO. , LTD.		
[标]发明人	LEE KWAN HEE		
发明人	LEE, KWAN-HEE		
IPC分类号	H01L27/32 H01L51/56 H05B33/22 H01L51/00 H01L51/50 H05B33/12		
CPC分类号	H01L27/3211 H01L27/3246 H01L51/0011 C02F1/74 C02F3/02 Y02W10/15		
优先权	1020040037555 2004-05-25 KR		
其他公开文献	EP1601033A1		
外部链接	Espacenet		

摘要(译)

公开了一种有机发光显示 (OLED) 器件及其制造方法。该器件可以包括布置在衬底上的单位像素区域。每个单位像素区域可以包括发射区域和非发射区域。像素电极可以至少设置在发射区域中。柱 (155) 可以设置在发射相同颜色的光的相邻单位像素区域的发射区域之间。柱可以比像素电极向上突出得更多。发射层 (145R) 可以设置在像素电极上。相对电极可以设置在发射层上。

