



(11) **EP 1 919 007 B1**

(12) **EUROPEAN PATENT SPECIFICATION**

(45) Date of publication and mention of the grant of the patent:  
**20.06.2012 Bulletin 2012/25**

(51) Int Cl.:  
**H01L 27/32<sup>(2006.01)</sup> H01L 51/00<sup>(2006.01)</sup>**

(21) Application number: **08151027.3**

(22) Date of filing: **25.11.2004**

(54) **Organic light emitting display**

Organische lichtemittierende Anzeigevorrichtung

Affichage électroluminescent organique

(84) Designated Contracting States:  
**DE FR GB NL**

(30) Priority: **29.11.2003 KR 20030087789**

(43) Date of publication of application:  
**07.05.2008 Bulletin 2008/19**

(62) Document number(s) of the earlier application(s) in accordance with Art. 76 EPC:  
**04090465.8 / 1 536 494**

(73) Proprietor: **Samsung Mobile Display Co., Ltd.**  
**Suwon-si**  
**Gyeonggi-do (KR)**

(72) Inventors:  
• **Kim, Mu-Hyun**  
**Gyeonggi-do (KR)**  
• **Song, Myung-Won**  
**c/o Samsung SDI Co, Ltd.**  
**Suwon-si**  
**Gyeonggi-do (KR)**

- **Kang, Tae-Min**  
**c/o Samsung SDI Co., Ltd.**  
**Suwon-si**  
**Gyeonggi-do (KR)**
- **Lee, Seong-Taek**  
**c/o Samsung SDI Co.,Ltd.**  
**Suwon-si**  
**Gyeonggi-do (KR)**
- **Cho, Yu-Sung**  
**c/o Samsung SDI Co.,Ltd.**  
**Suwon-si**  
**Gyeonggi-do (KR)**

(74) Representative: **Hengelhaupt, Jürgen et al**  
**Gulde Hengelhaupt Ziebig & Schneider**  
**Patentanwälte - Rechtsanwälte**  
**Wallstrasse 58/59**  
**10179 Berlin (DE)**

(56) References cited:  
**EP-A- 1 063 704 EP-A- 1 315 209**  
**US-A1- 2002 063 515 US-A1- 2003 151 358**  
**US-A1- 2003 209 976**

**EP 1 919 007 B1**

Note: Within nine months of the publication of the mention of the grant of the European patent in the European Patent Bulletin, any person may give notice to the European Patent Office of opposition to that patent, in accordance with the Implementing Regulations. Notice of opposition shall not be deemed to have been filed until the opposition fee has been paid. (Art. 99(1) European Patent Convention).

**Description**

## BACKGROUND OF THE INVENTION

## 5 Field of the Invention

**[0001]** The present invention relates to an organic light emitting display and, more particularly, to a full color active matrix organic light emitting display that can reduce a step height between an organic thin film layer and a lower electrode and relieve a taper angle of a substrate surface to prevent device failure from occurring.

10

## Description of the Related Art

15

**[0002]** Generally, an active matrix organic light emitting display (AMOLED) has a structure such that a thin film transistor (TFT) is arranged on a substrate in a form of a matrix, an anode connected to the TFT is formed, and an organic thin film layer and a cathode are formed thereon.

20

**[0003]** FIG. 1 is a cross-sectional view of a conventional bottom-emission organic light emitting display. Referring to FIG. 1, a buffer layer 105 is formed on an insulating substrate 100, and a semiconductor layer 110 including source/drain regions 111, 115 is formed on the buffer layer 105. A gate electrode 125 is formed on a gate insulating layer 120, and source/drain electrodes 141, 145 each connected to the source/drain regions 111, 115 through first holes 131, 135 are formed in an interlayer insulating layer 130.

**[0004]** An anode 170, a lower electrode connected to the drain electrode 145 of the source/drain electrode 141, 145 through a second hole 155, is formed on a passivation layer 150 and the drain electrode portion at the second hole 155, and an organic thin film layer 185 and a cathode 190, which is an upper electrode, are formed thereon.

25

**[0005]** In the conventional organic light emitting diode having the above structure, when a taper angle of the first hole or the second hole is large, there occurred a pinhole defect at the stepped region between around the second hole or the first hole and the anode 170, and a short defect of the anode and the cathode. Further, since the organic emission layer is not uniformly deposited around the first hole and the second hole and at the stepped region of the anode, there were problems that a dark spot was generated by a concentrated phenomenon of current density when a voltage between the anode and the cathode was applied, and that an emission region was reduced due to the generation of the dark spot to degrade picture quality.

30

**[0006]** To address the foregoing problems, an organic light emitting display employing a pixel defining layer made of the organic insulating layer with a planarization feature was disclosed in U.S. Patent No. 6,246,179.

35

**[0007]** FIG. 2 is a cross-sectional view of a conventional organic light emitting diode having a pixel defining layer. Referring to FIG. 2, a buffer layer 205 is formed on an insulating substrate 200, and a semiconductor layer 210 including source/drain regions 211, 215 are formed on the buffer layer 205. A gate electrode 225 is formed on a gate insulating layer 220, and source/drain electrodes 241, 245 connected to the source/drain regions 211, 215 through first holes 231, 235 are formed in an interlayer insulating layer 230.

40

**[0008]** An anode 270, which is a lower electrode connected to one of the source/drain electrodes 241, 245, e.g. the drain electrode 245, through a second hole 255, is formed on a passivation layer 250 and the drain electrode portion at the second hole 255. A pixel defining layer 265 including an opening 275 that exposes a portion of the anode 270 is formed, and an organic thin film layer (i.e., organic emission layer) 285 and a cathode 290, which is an upper electrode, are formed on the exposed portion of the anode 270 and the pixel defining layer 265. The organic thin film layer 285 has at least one organic emission layer such as a hole injection layer, a hole transporting layer, an emitting layer of R, G or B, a hole blocking layer, an electron transports layer and an electron injection layer.

45

**[0009]** The conventional top-emission organic light emitting display as described above solved the problem of the device defect caused by the stepped region of the substrate surface by using the pixel defining layer 265. However, when the organic emission layer is formed by the laser induced thermal imaging process, device reliability is changed depending on the taper angle and the step between the pixel defining layer 265 and the anode 270.

50

**[0010]** FIGS. 3A to 3C are cross-sectional views for illustrating a method of forming an organic emission layer using the laser induced thermal imaging process.

55

**[0011]** Referring to FIG. 3A, a TFT including the semiconductor layer 210, the gate electrode 225 and the source/drain electrodes 241, 245 is formed on the insulating substrate 200, and the anode 270 connected to the drain electrode 245 of the source/drain electrodes 241, 245 through the second hole 255 arranged in the passivation layer 250 is formed, as shown in FIG. 2. The pixel defining layer 265 having an opening 275 to expose a portion of the anode 270 is formed. A donor film 20 having an organic emission layer 21 is aligned and closely adheres to the substrate on which the TFT is formed (TFT substrate).

**[0012]** Next, as shown in FIG. 3B, while the donor film 20 adheres to the TFT substrate, a laser is irradiated with a pattern onto a predetermined region. When the laser is irradiated on the donor film 20, a portion of film where the laser

is irradiated is expanded and the organic emission layer 21 of the donor film 20 is patterned on the insulating substrate 200. When the donor film 20 is removed from the TFT substrate after completing a transfer process, an organic emission layer pattern 285a is formed on the anode 270 and the sidewall of the pixel defining layer 265, as shown in FIG. 3C.

**[0013]** When the organic emission layer pattern 285a is formed by the laser induced thermal imaging process, a distance h31 from the surface of the organic emission layer 21 to the upper surface of the anode 270 has a close relationship to the energy required during the laser induced thermal imaging process. That is, when the pixel defining layer 265 is deposited thick so that there is a high step between the pixel defining layer 265 and the anode 270, the distance h31 to which the donor film 20 should reach the opening 275 should be relatively increased. Further, to this end, the donor film 20 should be expanded relatively large, so that the irradiation energy of the laser should be increased.

**[0014]** As the irradiation energy becomes large, the surface temperature of the donor film 20 is also increased to the extent more than required, so that the characteristics of the organic emission layer pattern 285a transferred to the anode 270 and the pixel defining layer 265 are changed. When the characteristics of the emission layer are changed, there were problems of characteristic deterioration, such as the deterioration of the efficiency of the resultant organic light emitting display, a change in the color coordinate, and reduction of the life-time.

**[0015]** Further, when the organic emission layer is formed by the laser induced thermal imaging process, the donor film and the TFT substrate should adhere tightly with each other. However, when the taper angle of the pixel defining layer 265 is large, the donor film does not adhere tightly to the insulating substrate at the edge, so that there occurs an open defect 285c, or the organic emission layer pattern 285a within the opening 275 is open. Particularly, the donor film does not adhere tightly to the TFT substrate at the edge of the opening 275, so that the open defect 285c is generated at the edge of the opening 275. That is, when the organic emission layer is not rightly transferred or even when it is regularly transferred, a defect such as unclean transfer boundary is generated.

**[0016]** For instance, EP 1 315 309 A2 discloses an organic el display including an underlying layer formed over a substrate, an insulating layer formed over the substrate to expose a portion of the underlying layer, wherein a taper angle of the insulating layer of 15 degrees is used at an edge of the opening to prevent defects in the organic EL layer.

However, the embodiments are drawn to a display in which a lower electrode is formed under an interlayer insulating layer. In US 2003/0151358 A1, to avoid the formation of defects at a lower electrode edge, the edges are covered by an edge cover film which has a taper angle of 30 degrees in a region in which the organic layer is formed on the edge cover film and the organic layer covers the lower electrode only at its upper planar side. EP 1 063 704 A2 discloses the formation of a lower electrode on a interlayer insulating layer. To avoid the formation of defects, the el layer is formed to entirely cover the lower electrode.

**[0017]** US 2002/0063515 A1 discloses a light-emitting display device to improve the throughput efficiency. The light-emitting display device is provided with a plurality of anodes isolated from each other by isolating films in the shape of islands, cathodes arranged opposite to the anodes and a plurality of pixels disposed in the form of a matrix. The cathode is provided with a declined surface between adjacent ones of the pixels. The declined surface defines an acute angle smaller than 90° with respect to the light-projecting surface. US 2003/0209976 discloses an electroluminescent panel comprising a hole injecting electrode formed on a TFT structure and a first planarization layer, a second planarization layer being arranged on top of the hole injecting electrode forming a contact hole and having a coating film f formed also on the side wall of the contact hole.

**[0018]** FIG. 6 is a picture showing an edge open defect of the conventional organic light emitting display having a pixel defining layer with a large taper angle and a high step. Referring to FIG. 6, it shows that when the pixel defining layer is formed at a taper angle of more than 40° and in a step height of 10,000Å, the edge open defect is generated at the opening, which is a boundary between the anode and the pixel defining layer. During the laser transfer process, the characteristics of the organic emission layer are changed by the high energy required due to the high step of the pixel defining layer, so that the efficiency of the organic emission layer is degraded to less than 30%. In this case, for the blue organic emission layer, the color coordinate was changed from 0.15, 0.18 to 0.17, 0.25 along with the efficiency reduction, and for the red organic emission layer, a mixed color phenomenon occurs due to the emission of the electron transporting layer at the portion where the edge open defect is generated.

## SUMMARY OF THE INVENTION

**[0019]** It is, therefore, an object of the present invention to provide an improved organic light emitting display.

**[0020]** It is also an object of the present invention to provide an organic light emitting display that has a structure with a reduced step height and a reduced taper angle of a pixel defining layer to prevent device failure from occurring in an organic emission layer.

**[0021]** It is another object of the present invention to provide an organic light emitting display to which the laser induced thermal imaging process can be applied.

**[0022]** The present invention provides an organic light emitting display comprising: a TFT substrate comprising an insulating substrate a semiconductor layer having a source region and a drain region, a first insulating layer formed on

the TFT substrate having holes that expose a portion of the source/drain regions and a TFT having source/drain electrodes connected to the source/drain regions through the holes; a lower electrode formed on the first insulating layer and connected to one of the source/drain electrodes; a second insulating layer having a first opening that exposes a first portion of the lower electrode, the second insulating layer being a passivation layer formed on the TFT substrate including the first insulating layer and the lower electrode at an edge thereof; a third insulating layer being a pixel defining layer formed on the second insulating layer and the lower electrode at an edge thereof and having a second opening that exposes a second portion of the lower electrode which is within the first portion of the lower electrode; an organic thin film layer formed on the third insulating layer and the second portion of the lower electrode; and an upper electrode formed on the organic thin film layer, wherein the third insulating layer has a taper angle of less than 40° at an edge of the second opening, and wherein a step height between the upper surface of the lower electrode and the bottom surface of the organic thin film layer formed on the third insulating layer is less than or equal to about 3.000Å.

#### BRIEF DESCRIPTION OF THE DRAWINGS

**[0023]** A more complete appreciation of the present invention, and many of the above and other features and advantages of the present invention, will be readily apparent as the same becomes better understood by reference to the following detailed description when considered in conjunction with the accompanying drawings. In the following, Figs. 1-9 are not part of the invention though necessary to understand it. Like reference symbols in the drawings indicate the same or similar components, wherein:

**[0024]** FIG. 1 is a cross-sectional view of a conventional organic light emitting display;

**[0025]** FIG. 2 is a cross-sectional view of a conventional organic light emitting display having a pixel defining layer;

**[0026]** FIGS. 3A TO 3C are cross-sectional views for illustrating a method of forming an organic emission layer using a laser induced thermal imaging process, for a conventional organic light emitting display having a pixel defining layer; first insulating layer and connected to one of the source/drain electrodes; a second insulating layer having a first opening that exposes a first portion of the lower electrode; a third insulating layer having a second opening that exposes a second portion of the lower electrode which is within the first portion of the lower electrode; an organic thin film layer formed on the third insulating layer and the second portion of the lower electrode; and an upper electrode formed on the organic thin film layer, wherein the third insulating layer has a taper angle of less than 40° at an edge of the second opening, and wherein a step height between the upper surface of the lower electrode and the bottom surface of the organic thin film layer formed on the third insulating layer is less than or equal to about 3,000Å.

#### BRIEF DESCRIPTION OF THE DRAWINGS

**[0027]** A more complete appreciation of the present invention, and many of the above and other features and advantages of the present invention, will be readily apparent as the same becomes better understood by reference to the following detailed description when considered in conjunction with the accompanying drawings in which like reference symbols indicate the same or similar components, wherein:

**[0028]** FIG. 1 is a cross-sectional view of a conventional organic light emitting display;

**[0029]** FIG. 2 is a cross-sectional view of a conventional organic light emitting display having a pixel defining layer;

**[0030]** FIGS. 3A TO 3C are cross-sectional views for illustrating a method of forming an organic emission layer using a laser induced thermal imaging process, for a conventional organic light emitting display having a pixel defining layer;

**[0031]** FIG. 4 is a graph for illustrating a relationship between a radius of curvature made by a donor film which does not completely adhere to the opening and an open edge defect, for an organic light emitting display;

**[0032]** FIG. 5 is a diagram for illustrating a relationship between an open edge defect and a taper angle of a pixel defining layer for an organic light emitting display;

**[0033]** FIG. 6 is a picture showing an open edge defect generated when a pixel defining layer has a high step and a large taper angle for a conventional organic light emitting display;

**[0034]** FIG. 7 is a cross-sectional view of an organic light emitting display;

**[0035]** FIG. 8 is a cross-sectional view of an organic light emitting display;

**[0036]** FIG. 9 is a cross-sectional view of an organic light emitting display;

**[0037]** FIG. 10 is a cross-sectional view of an organic light emitting display according to an embodiment of the present invention; and

**[0038]** FIG. 11 is a picture showing that an open edge defect is not generated when a pixel defining layer has a low taper angle and a low step, for an organic light emitting display according to the embodiment of the present invention.

#### DETAILED DESCRIPTION OF THE PREFERRED EMBODIMENTS

**[0039]** The present invention will now be fully understood hereinafter with the help of the accompanying drawings, in

which a preferred embodiment of the invention is shown. This invention may, however, be embodied in different forms within the scope defined in the appended claims. In the drawings, the thickness of layers and areas are exaggerated for clarity. Like numbers refer to like elements throughout the specification.

5 [0040] FIG. 7 is a cross-sectional view of a top-emission organic light emitting display. Referring to FIG. 7, a buffer layer 305 is formed on an insulating substrate 300, and a semiconductor layer 310 having source/drain regions 311, 315 is formed on the buffer layer 305. A gate electrode 325 is formed on a gate insulating layer 320, and source/drain electrodes 341, 345 connected to the source/drain regions 311, 315 through first holes 331, 335 are formed in an interlayer insulating layer 330.

10 [0041] A planarization layer 360 is formed on a passivation layer 350, and an anode 370, which is a lower electrode connected to one of the source/drain electrodes 341, 345, for example, the drain electrode 345, through a second hole 355, is formed in the planarization layer 360. A pixel defining layer 365 including an opening 375 that exposes a portion of the anode 370 is formed on the planarization layer, and an organic thin film layer 385 and a cathode 390 are sequentially formed on the TFT substrate. The organic thin film layer 385 includes at least an emission layer selected from a hole injection layer, a hole transporting layer, R, G or B emitting layer, a hole blocking layer, an electron transporting layer and an electron injection layer. The organic thin film layer includes an organic emission layer formed by the laser induced thermal imaging process.

15 [0042] According to this display, in order to prevent the edge open defect at the opening edge of the pixel defining layer and to prevent characteristic deterioration of the emission layer due to high energy in forming the organic emission layer using the laser induced thermal imaging process, it is desirable that a taper angle  $\theta_{31}$  of the pixel defining layer 365 is below  $40^\circ$  and that a step height  $d_{31}$ , as shown in FIG. 7, from the upper surface of the anode 370, the lower electrode, to the upper surface of the pixel defining layer 365 is below or equal to about  $3,000\text{\AA}$ .

20 [0043] FIG. 4 is a graph for illustrating a relationship between a radius of curvature of a donor film and an open edge defect, when an organic emission layer of an organic light emitting display is formed by the laser induced thermal imaging process as in the embodiment of the present invention, and FIG. 5 is a diagram for illustrating a relationship between an open edge defect and a taper angle of a pixel defining layer. In FIG. 5, each line indicates the edge open defect corresponding to the ratio of the curvature radius to the step.

25 [0044] Referring to FIGS. 4 and 5, a radius  $R$  is a radius of curvature 43 made by a donor film which does not completely adhere to the opening when the donor film is made adhere to the opening of the pixel defining layer 41 for laser transfer. The step height  $d_4$  is a distance from the upper surface of the anode 40, the lower electrode, to the upper surface of the pixel defining layer 41. Further, the edge open defect means that the edge portion of the opening, which the organic emission layer is not formed at or completely attached to, of the pixel defining layer 41.

30 [0045] Assuming that the donor film does adhere tightly to the TFT substrate at the opening of the pixel defining layer 41, that is, assuming that the donor film adheres tightly to the anode 40 and the pixel defining layer 41, the curvature radius  $R$  of the donor film becomes "0". Meanwhile, the lower the adhesion tightness to the TFT substrate is at the opening of the pixel defining layer 41, the larger the curvature radius  $R$  of the donor film becomes, whereas the higher the adhesion tightness to the TFT substrate is, the smaller the curvature radius  $R$  of the donor film becomes. Further, the adhesion tightness of the donor film to the TFT substrate is increased as the taper angle of the pixel defining layer 41 is low and the step is low. Accordingly, the curvature radius  $R$  of the donor film becomes small.

35 [0046] Therefore, it will be noticed that as the curvature radius of the donor film becomes smaller, the edge open defect of the organic emission layer is reduced. The organic emission layer is not formed in the region where the edge open defect is generated, so that there occurs characteristic deterioration such as a change of the color coordinate due to the color mixing.

40 [0047] Accordingly, to prevent this characteristic deterioration, the edge open defect should be reduced. The edge open defect needs to be at least below  $1.0\ \mu\text{m}$  for preventing the color mixing due to the edge open defect detected neither by naked eyes nor by the measuring device. For the edge open defect to be below  $1.0\ \mu\text{m}$ , it is desirable that the taper angle of the pixel defining layer is below  $40^\circ$ . Further, from FIG. 5, it will be appreciated that as the curvature radius of the donor film and the step are smaller, the edge open defect is reduced.

45 [0048] FIG. 11 is a picture showing a cross-sectional structure of an organic light emitting display in which the organic emission layer is formed by the laser induced thermal imaging process. Referring to FIG. 11, it shows that, when the pixel defining layer is formed such that its taper angle is below  $40^\circ$  and the organic light emitting display is fabricated such that the step height between the anode and the pixel defining layer is below or equal to about  $3,000\text{\AA}$ , the edge open defect is not generated while forming the organic emission layer using the laser induced thermal imaging process at the edge of the opening.

50 [0049] Table 1 shows characteristic data of the device fabricated by the laser induced thermal imaging process, based on the laser transfer conditions and the step between the pixel electrode and the pixel defining layer.

55 [0050] The organic light emitting displays used in Table 1 are red light emitting displays, which are fabricated with different steps and taper angles to measure the device characteristics, that is, with the step heights such as  $10,000\text{\AA}$ ,  $5,000\text{\AA}$  and  $3,000\text{\AA}$  and with the taper angle such as  $40^\circ$  and  $20^\circ$ . For each red light emitting display, the pixel defining

layer is formed on the anode with 40° and 20° taper angles and with 10,000Å, 5,000Å and 3,000Å step heights. After forming the pixel defining layer, poly(3, 4-ethylene dioxythiophene (PEDOT), which is a polymer charge transporting layer, is formed in a thickness of 500Å by a spin-coating process, and the annealing process is performed using a hot plate at 200°C during 5 minutes.

**[0051]** Next, 4,4'-bis-[N-(1-naphthyl)-N-phenylamino]biphenyl (NPB), which is a monomer hole transporting layer, is formed in a thickness of 300Å by a vacuum deposition method. Subsequently, the monomer R emission layer (the emission layer where 12% weigh fraction of TER004 is doped into TMM004 host) is patterned in a thickness of 300Å by the laser induced thermal imaging process. Then, 50Å thick bis(2-methyl-8-quinolinolato)(4-phenylphenolato)aluminum (BAIq) and 200Å tris(8-quinolinolato)-aluminum (Alq3) are successively deposited as a hole blocking layer and a monomer electron transporting layer. Next, LiF/A1 is deposited by a resistance heating process to form the cathode. And then, it is encapsulated by an encapsulating substrate using a sealant to fabricate the red light emitting display.

**[0052]** From Table 1, it will be appreciated that in case the step height between the anode and the pixel defining layer is large, the laser energy is increased due to the large step height, when the emission layer is patterned by the laser induced thermal imaging process. For this reason, it is shown that the organic emission layer has degraded characteristics and a reduced efficiency due to the laser energy, and the color coordinate is worsened due to the emission of the hole blocking layer or the electron transporting layer at the portion where the open defect of the edge of the emission region is generated.

**[0053]** Further, from Table 1, it will be appreciated that the red light emitting display without edge open defect and the degraded characteristics has color coordinates of 0.67, 0.33 and efficiency more than 5.0Cd/A. The conditions that meet such device characteristics are a step height of 3,000Å and a taper angle less than 40°.

Table 1

Step Height	Taper Angle (degree)	Laser Energy (J/cm <sup>2</sup> )	Edge Open (μm)	Efficiency (Cd/A)	Color Coordinate
10,000Å	40	1.5	5.0	1.5	0.58, 0.35
5,000Å	40	1.0	1.5	4.1	0.64, 0.34
3,000Å	40	0.7	0.5	5.3	0.67, 0.33
3,000Å	20	0.7	0	6.0	0.67, 0.33

**[0054]** FIG. 8 is a cross-sectional view illustrating a top-emission organic light emitting display according to a second embodiment of the present invention. Referring to FIG. 8, a buffer layer 405 is formed on an insulating substrate 400, and a semiconductor layer 410 including source/drain regions 411, 415 are formed on the buffer layer 405. A gate electrode 425 is formed on a gate insulating layer 420, and source/drain electrodes connected to the source/drain regions 411, 415 are formed in an interlayer insulating layer 430 through first holes 431, 435.

**[0055]** A planarization layer 460 is formed on a passivation layer 450, and an anode 470, which is a lower electrode connected to one of the source/drain electrodes 441, 445, for example, the drain electrode 445 through a second hole 455, is formed in the planarization layer 460. An organic thin film layer 485 and a cathode 490 are formed on the TFT substrate. The organic thin film layer 485 includes at least an emission layer selected from a hole injection layer, a hole transporting layer, R, G, or B emitting layer, a hole blocking layer, an electron transporting layer and an electron injection layer. The organic thin film layer includes an organic emission layer formed by the laser induced thermal imaging process.

**[0056]** According to the present invention, in order to prevent open defect of the organic emission layer caused by the stepped region of the anode, which is a lower electrode, when the organic emission layer is formed by the laser induced thermal imaging process, it is desirable that the taper angle θ41 of the anode 470 is below 40°.

**[0057]** FIG. 9 is a cross-sectional view illustrating a bottom-emission organic light emitting display according to a third embodiment of the present invention. Referring to FIG. 9, a buffer layer 505 is formed on an insulating substrate 500, and a semiconductor layer 510 including source/drain regions 511, 515 are formed on the buffer layer 505. A gate electrode 525 is formed on a gate insulating layer 520, and source/drain electrodes 541, 545 is formed in an interlayer insulating layer 530 through first holes 531, 535.

**[0058]** An anode 570, which is a lower electrode connected to one of the source/drain electrodes 541, 545, for example, the drain electrode 545, through a second hole 555, is formed in a passivation layer 550. A pixel defining layer 565 including an opening 575 that exposes a portion of the anode 570 is formed, and an organic thin film layer and a cathode 590, an upper electrode, are formed on the pixel defining layer 565 and the anode 570 of the opening 575. The organic thin film layer 585 includes at least one organic layer selected from a hole injection layer, a hole transporting layer, R, G, or B emitting layer, a hole blocking layer, an electron transporting layer and an electron injection layer. The emission layer includes an organic thin film layer formed by a laser induced thermal imaging process.

**[0059]** According to the present invention, in order to prevent edge open defects at the opening edge of the pixel defining layer, and to prevent characteristic deterioration of the emission layer caused by high energy when the organic emission layer is formed by the laser induced thermal imaging process, it is desirable that a taper angle  $\theta_{51}$  of the pixel defining layer 565 is below  $40^\circ$ , and that a step height  $d_{51}$  from the upper surface of the anode 570, the lower electrode, to the upper surface of the pixel defining layer 565 is below or equal to about  $3,000\text{\AA}$ .

**[0060]** FIG. 10 is a cross-sectional view illustrating an organic light emitting display according to an embodiment of the present invention. Referring to FIG. 10, a buffer layer 605 is formed on an insulating substrate 600, and a semiconductor layer 610 including source/drain regions 611, 615 are formed on the buffer layer 605. A gate electrode 625 is formed on a gate insulating layer 620, and source/drain electrodes 641, 645 connected to the source/drain regions 611, 615 through first holes 631, 635 are formed in an interlayer insulating layer 630. An anode 670 connected to one of the source/drain electrodes 641, 645, for example, the drain electrode 645, is formed in the interlayer insulating layer 630.

**[0061]** A passivation layer 650 including a first opening that exposes a first portion of the anode 670 is formed on the TFT substrate, and a pixel defining layer 665 including a second opening 675 that exposes a second portion of the anode 670 is formed on the passivation layer 650.

**[0062]** An organic thin film layer 685 and a cathode 690, which is an upper electrode, are formed on the pixel defining layer 665 and an anode 670 in the second opening 675. The organic thin film layer 685 includes at least one organic layer selected from a hole injection layer, a hole transporting layer, R, G or B emitting layer, a hole blocking layer, an electron transporting layer and an electron injection layer. The organic thin film layer is formed by a laser induced thermal imaging process.

**[0063]** According to the present invention, in order to prevent edge open defects at the second opening edge of the pixel defining layer, and to prevent characteristic deterioration of the emission layer caused by high energy when the organic emission layer is formed by the laser induced thermal imaging process, it is desirable that a second taper angle  $\theta_{61}$  of the pixel defining layer 665 is below  $40^\circ$ , and that a step height  $d_{61}$  from the upper surface of the anode 670, the lower electrode, to the upper surface of the pixel defining layer 665 is below or equal to about  $3,000\text{\AA}$ .

**[0064]** According to this embodiment of the present invention, the second opening 675 of the pixel defining layer 665 has the second taper angle  $\theta_{61}$ , and the first opening of the passivation layer 650 has a first taper angle  $\theta_{62}$ . Since the edge open defect depends on the second taper angle  $\theta_{61}$  of the pixel defining layer 665 during a laser induced thermal imaging process, it is desirable that the pixel defining layer has the second taper angle  $\theta_{61}$  of less than  $40^\circ$ . The first exposed portion of the anode 670 is within the second exposed portion of the anode 670.

**[0065]** The organic light emitting display according to the embodiment of the present invention can be applied to display devices having a bottom-emission structure, where the anode, or the lower electrode, is formed with a transparent electrode, and the cathode, or the upper electrode, is formed with a reflective electrode to emit light in a direction of the TFT substrate; a top-emission structure, where the anode, or the lower electrode, is formed with the reflective electrode, and the cathode is formed with the transparent electrode to emit light in a direction opposite to the TFT substrate; and a double-side-emission structure where the anode, or the lower electrode, and the cathode, or the upper electrode, are formed with the transparent electrodes to emit light both in the direction of the TFT substrate and in the direction opposite to the TFT substrate.

**[0066]** Further, although the embodiments of the present invention has been described with regard to the conventional organic light emitting display, in which the anode, the organic thin film layer and the cathode are sequentially stacked, it can be also applied to the inverted organic light emitting display, in which the cathode, the organic emission layer and the anode are sequentially electrode.

**[0067]** According to the present invention as described above, an organic thin film for relieving a taper angle is formed on the anode, thereby preventing the defect around the first hole and the second hole as well as the defect of the organic emission layer, so that the reliability and yield can be enhanced.

**[0068]** Although a preferred embodiments of the present invention has been described, those skilled in the art will appreciate that a variety of modifications and changes can be made without departing from the scope of the present invention described in the following claims.

## Claims

1. An organic light emitting display, comprising:

a TFT substrate comprising an insulating substrate (600), a semiconductor layer (610) having a source region (611) and a drain region (615), a first insulating layer (630) formed on the TFT substrate having holes (631, 635) that expose a portion of the source region (611) and the drain region (615) and a thin film transistor having a source electrode (641) connected to the source region (611) and a drain electrode (645) connected to the drain region (615) through the holes (631, 635);

a lower electrode (670) formed on the first insulating layer (630) and connected to one of the source electrode (641) and the drain electrode (645);

a second insulating layer (650) having a first opening that exposes a first portion of the lower electrode (670), the second insulating layer (650) being a passivation layer formed on the TFT substrate including the first insulating layer (630) and the lower electrode (670) at an edge thereof;

a third insulating layer (665) being a pixel defining layer formed on the second insulating layer (650) and the lower electrode (670) at an edge thereof and having a second opening (675) that exposes a second portion of the lower electrode (670), said second portion of the lower electrode (670) being within the first portion of the lower electrode (670);

an organic thin film layer (685) formed on the third insulating layer (665) and the second portion of the lower electrode (670); and

an upper electrode (690) formed on the organic thin film layer (685);

**characterized in that** the third insulating layer (665) has a taper angle ( $\theta 61$ ) of less than  $40^\circ$  at an edge of the second opening (675), and a step height ( $d61$ ) between the upper surface of the lower electrode (670) at the second opening (675) and the bottom surface of the organic thin film layer (685) formed on the third insulating layer (665) is less than or equal to  $3,000 \text{ \AA}$ .

2. The organic light emitting display according to claim 1, wherein the lower electrode (670) is one of an anode and a cathode, and the upper electrode (690) is the other one.

3. The organic light emitting display according to claim 1, wherein the lower electrode (670) is a transparent electrode, and the upper electrode (690) acts as a reflective or transparent electrode, and light emitted from the organic thin film layer (685) is emitted in a direction of the TFT substrate or is emitted in both the direction of TFT substrate and a direction opposite to the TFT substrate.

4. The organic light emitting display according to claim 1, wherein the organic thin film layer (665) includes at least one organic layer selected from the group consisting of a hole injection layer, a hole transporting layer, an emission layer, a hole blocking layer, an electron transporting layer and an electron injection layer, and the organic thin film layer (665) includes an organic layer formed by a laser induced thermal imaging process.

## Patentansprüche

1. Organische lichtemittierende Anzeigevorrichtung, umfassend:

ein TFT-Substrat, umfassend: ein Isoliersubstrat (600), eine Halbleiterschicht (610) mit einem Source-Bereich (611) und einem Drain-Bereich (615), eine auf dem TFT-Substrat ausgebildete erste Isolierschicht (630) mit Löchern (631, 635), die einen Abschnitt des Source-Bereiches (611) und des Drain-Bereiches (615) freilegen, und einen Dünnschichttransistor mit einer Source-Elektrode (641), die mit dem Source-Bereich (611) verbunden ist, und einer Drain-Elektrode (645), die mit dem Drain-Bereich (615) verbunden ist, jeweils über die Löcher (631, 635);

eine untere Elektrode (670), die auf der ersten Isolierschicht (630) ausgebildet ist und mit der Source-Elektrode (641) oder der Drain-Elektrode (645) verbunden ist;

eine zweite Isolierschicht (650) mit einer ersten Öffnung, die einen ersten Abschnitt der unteren Elektrode (670) freilegt, wobei die zweite Isolierschicht (650) eine Passivierungsschicht ist, die auf dem TFT-Substrat einschließlich der ersten Isolierschicht (630) und der unteren Elektrode (670) an einem Rand davon ausgebildet ist;

eine dritte Isolierschicht (665), die eine pixeldefinierende Schicht ist, die auf der zweiten Isolierschicht (650) und der unteren Elektrode (670) an einem Rand davon ausgebildet ist und eine zweite Öffnung (675) aufweist, die einen zweiten Abschnitt der unteren Elektrode (670) freilegt, wobei sich der zweite Abschnitt der unteren Elektrode (670) innerhalb des ersten Abschnitts der unteren Elektrode (670) befindet;

eine organische Dünnschicht-Schicht (685), die auf der dritten Isolierschicht (665) und dem zweiten Abschnitt der unteren Elektrode (670) ausgebildet ist; und

eine obere Elektrode (690), die auf der organischen Dünnschicht-Schicht (685) ausgebildet ist;

**dadurch gekennzeichnet, dass** die dritte Isolierschicht (665) einen Verjüngungswinkel ( $\theta 61$ ) von weniger als  $40^\circ$  an einem Rand der zweiten Öffnung (675) aufweist und eine Stufenhöhe ( $d61$ ) zwischen der oberen Oberfläche der unteren Elektrode (670) an der zweiten Öffnung (675) und der unteren Oberfläche der organischen Dünnschicht-Schicht (685), die auf der dritten Isolierschicht (665) ausgebildet ist, kleiner oder gleich  $3.000 \text{ \AA}$  ist.

2. Organische lichtemittierende Anzeigevorrichtung nach Anspruch 1, wobei die untere Elektrode (670) eine Anode oder eine Kathode ist und die obere Elektrode (690) die jeweils andere ist.
- 5 3. Organische lichtemittierende Anzeigevorrichtung nach Anspruch 1, wobei die untere Elektrode (670) eine transparente Elektrode ist und die obere Elektrode (690) als reflektierende oder transparente Elektrode wirkt und von der organischen Dünnschicht-Schicht (685) emittiertes Licht in einer Richtung des TFT-Substrats emittiert wird oder sowohl in der Richtung des TFT-Substrats als auch in einer Richtung entgegengesetzt zum TFT-Substrat emittiert wird.
- 10 4. Organische lichtemittierende Anzeigevorrichtung nach Anspruch 1, wobei die organische Dünnschicht-Schicht (665) mindestens eine organische Schicht, ausgewählt aus der Gruppe bestehend aus einer Lochinjektionsschicht, einer Lochtransportschicht, einer Emissionsschicht, einer Lochsperrschicht, einer Elektronentransportschicht und einer Elektroneninjektionsschicht, einschließt und die organische Dünnschicht-Schicht (665) eine durch einen laserangeregten thermischen Abbildungsprozess ausgebildete organische Schicht einschließt.
- 15

## Revendications

- 20 1. Dispositif d'affichage électroluminescent organique, comprenant :

un substrat TFT comprenant un substrat isolant (600), une couche semiconductrice (610) ayant une région de source (611) et une région de drain (615), une première couche isolante (630) formée sur le substrat TFT ayant des trous (631,635) qui exposent une partie de la région de source (611) et de la région de drain (615) et un transistor à couches minces ayant une électrode de source (641) reliée à la région de source (611) et une

25 électrode de drain (645) reliée à la région de drain (615) à travers les trous (631,635) ;

une électrode inférieure (670) formée sur la première couche isolante (630) et reliée à l'une de l'électrode de source (641) et de l'électrode de drain (645) ;

une deuxième couche isolante (650) ayant une première ouverture qui expose une première partie de l'électrode inférieure (670), la deuxième couche isolante (650) étant une couche de passivation formée sur le substrat TFT comportant la première couche isolante (630) et l'électrode inférieure (670) au niveau de son bord ;

une troisième couche isolante (665) étant une couche définissant des pixels formée sur la deuxième couche isolante (650) et l'électrode inférieure (670) au niveau de son bord et ayant une deuxième ouverture (675) qui expose une deuxième partie de l'électrode inférieure (670), ladite deuxième partie de l'électrode inférieure (670) étant dans la première partie de l'électrode inférieure (670) ;

une couche en film mince organique(685) formée sur la troisième couche isolante (665) et sur la deuxième partie de l'électrode inférieure (670) ; et

une électrode supérieure (690) formée sur la couche en film mince organique(685) ;

### **caractérisé en ce que**

la troisième couche isolante (665) présente un angle de biseau ( $\theta 61$ ) inférieur à  $40^\circ$  au niveau d'un bord de la deuxième ouverture (675), et une hauteur de marche ( $d61$ ) entre la surface supérieure de l'électrode inférieure (670) au niveau de la deuxième ouverture (675) et la surface inférieure de la couche en film mince organique (685) formée sur la troisième couche isolante (665) est inférieure ou égale à 3000 Å.

- 45 2. Dispositif d'affichage électroluminescent organique selon la revendication 1, dans lequel l'électrode inférieure (670) est l'une d'une anode et une cathode, et l'électrode supérieure (690) est l'autre.
3. Dispositif d'affichage électroluminescent organique selon la revendication 1, dans lequel l'électrode inférieure (670) est une électrode transparente, et l'électrode supérieure (690) joue le rôle d'une électrode réfléchissante ou transparente, et la lumière émise à partir de la couche en film mince organique (685) est émise dans une direction du substrat TFT ou est émise à la fois dans la direction du substrat TFT et dans la direction opposée au substrat TFT.
- 50 4. Dispositif d'affichage électroluminescent organique selon la revendication 1, dans lequel la couche en film mince organique (665) comporte au moins une couche organique sélectionnée dans le groupe constitué d'une couche d'injection de trous, d'une couche de transport de trous, d'une couche d'émission, d'une couche de blocage de trous, d'une couche de transport d'électrons et d'une couche d'injection d'électrons, et la couche en film mince organique (665) comporte une couche organique formée par processus d'imagerie thermique induite par laser.
- 55

FIG. 1

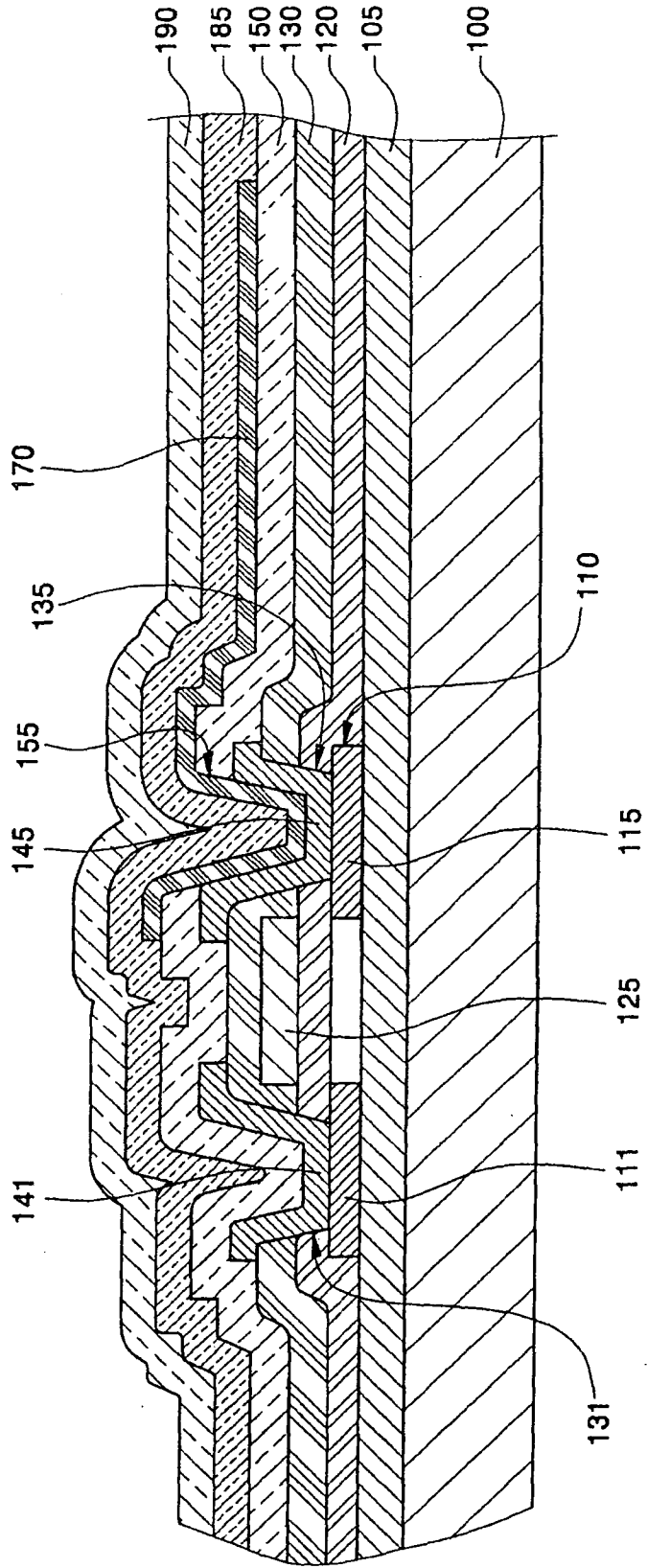

FIG. 2

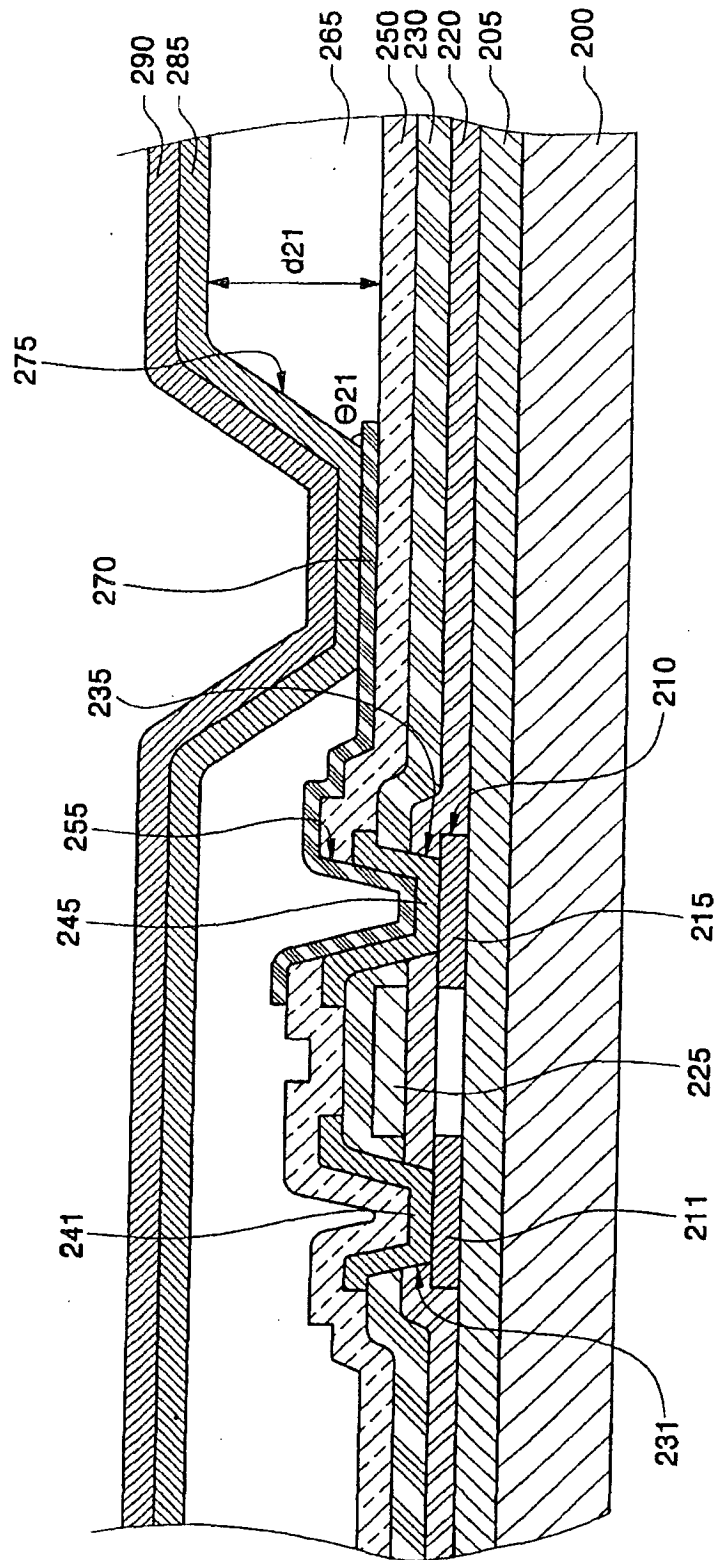

FIG. 3A

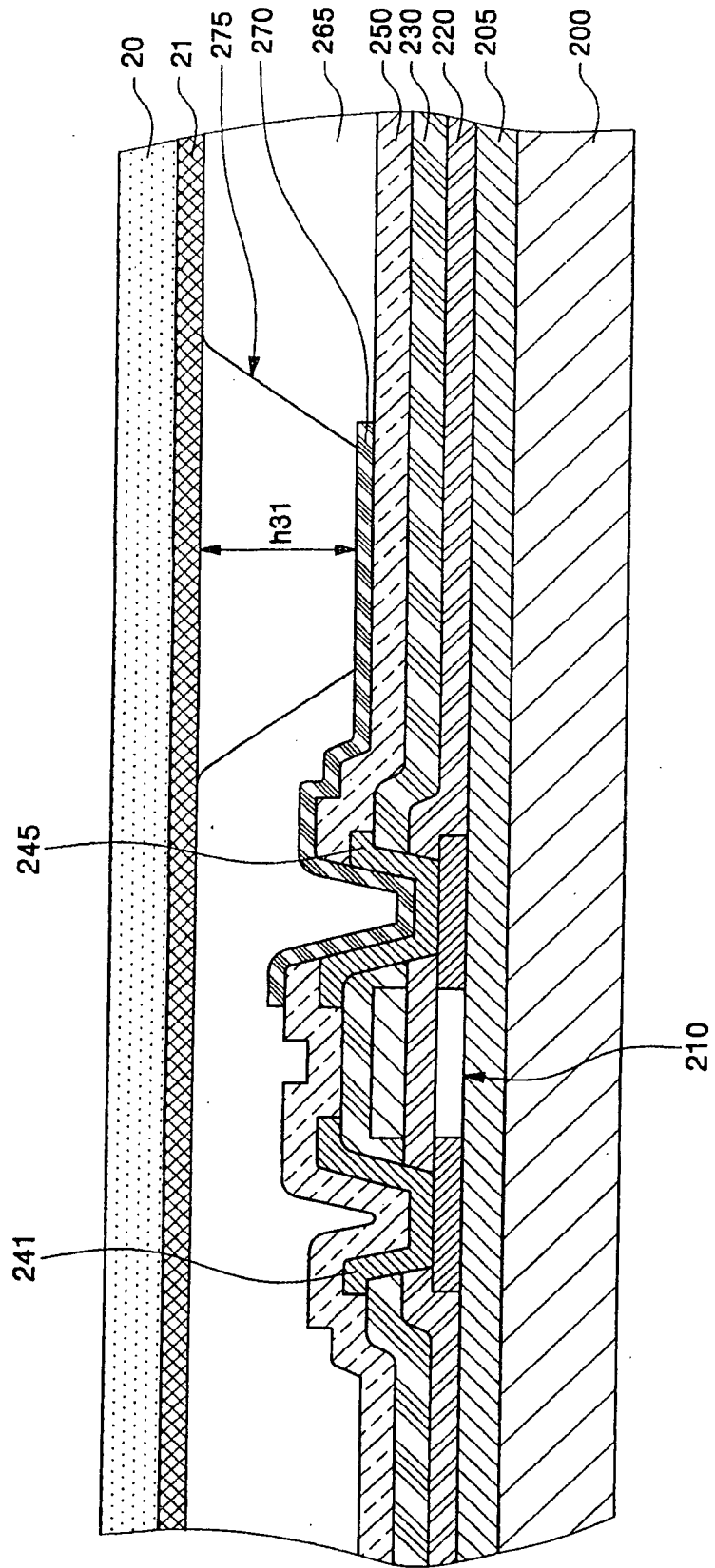

FIG. 3B

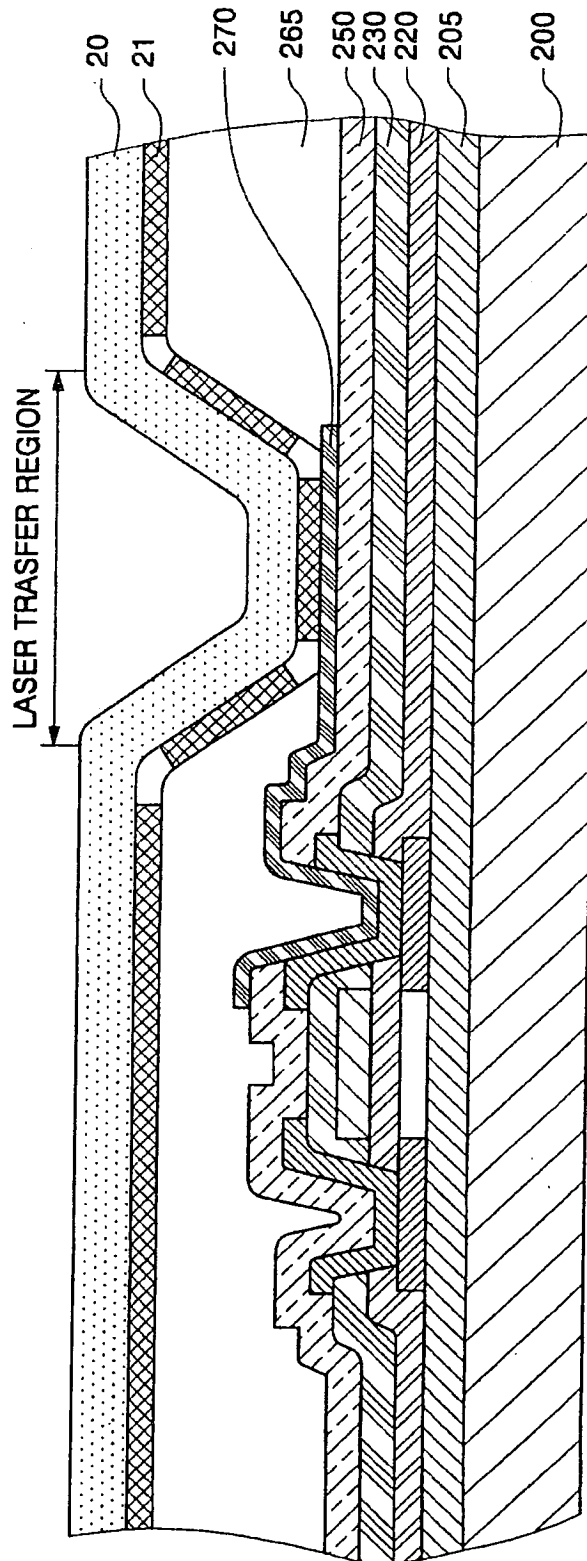

FIG. 3C

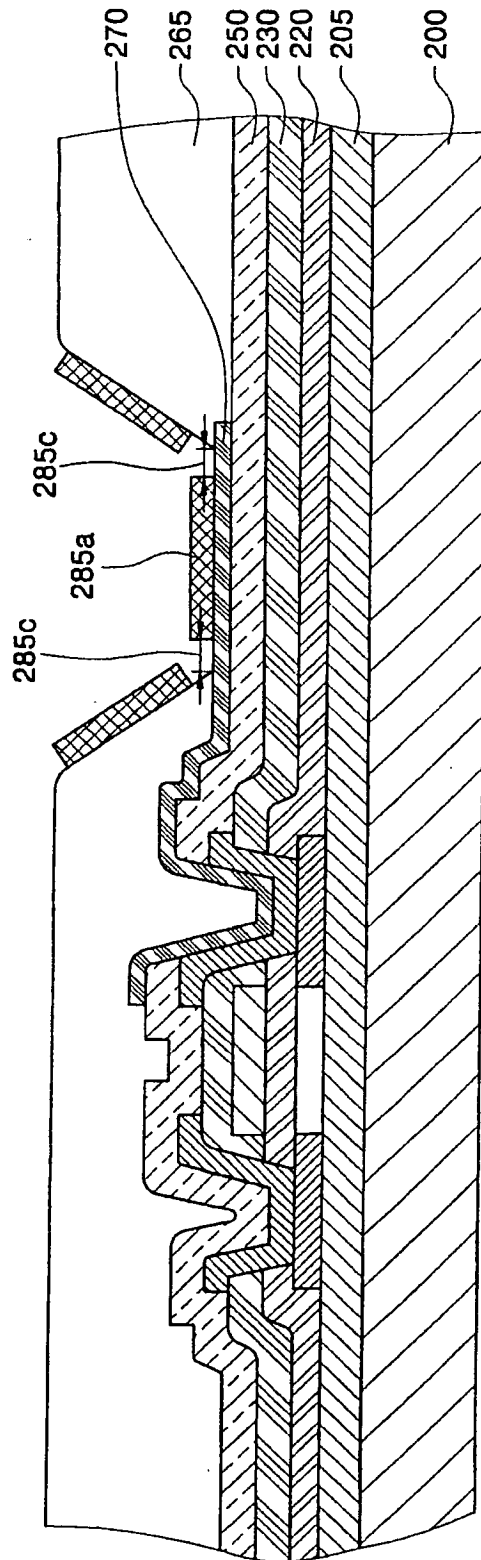

FIG. 4

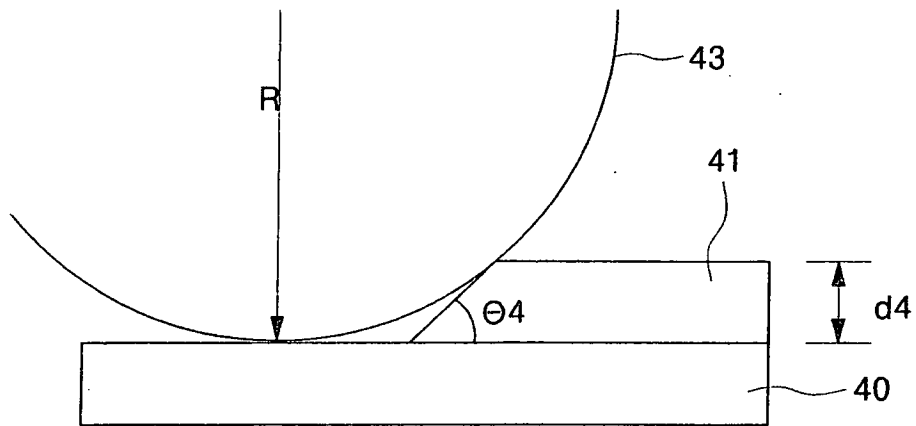

FIG. 5

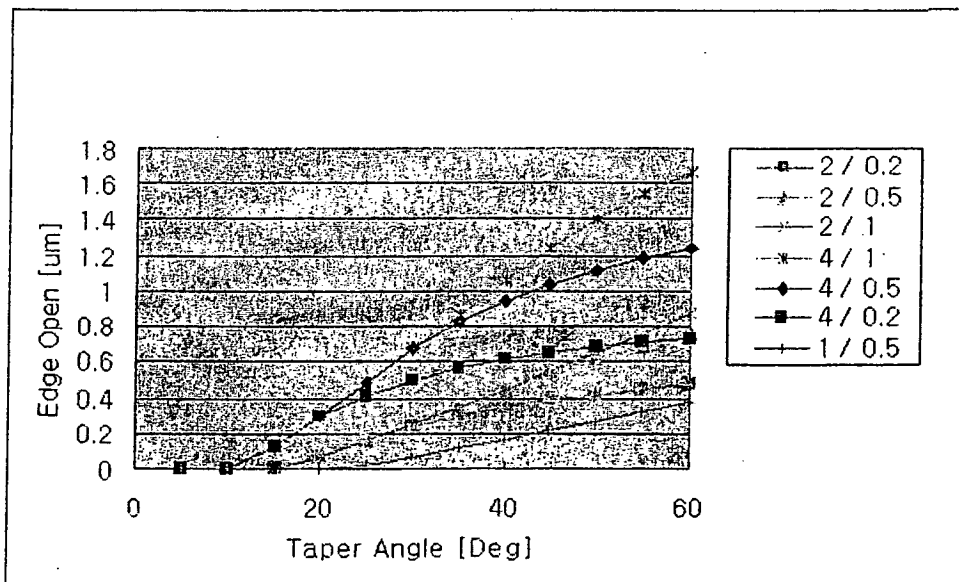

FIG. 6

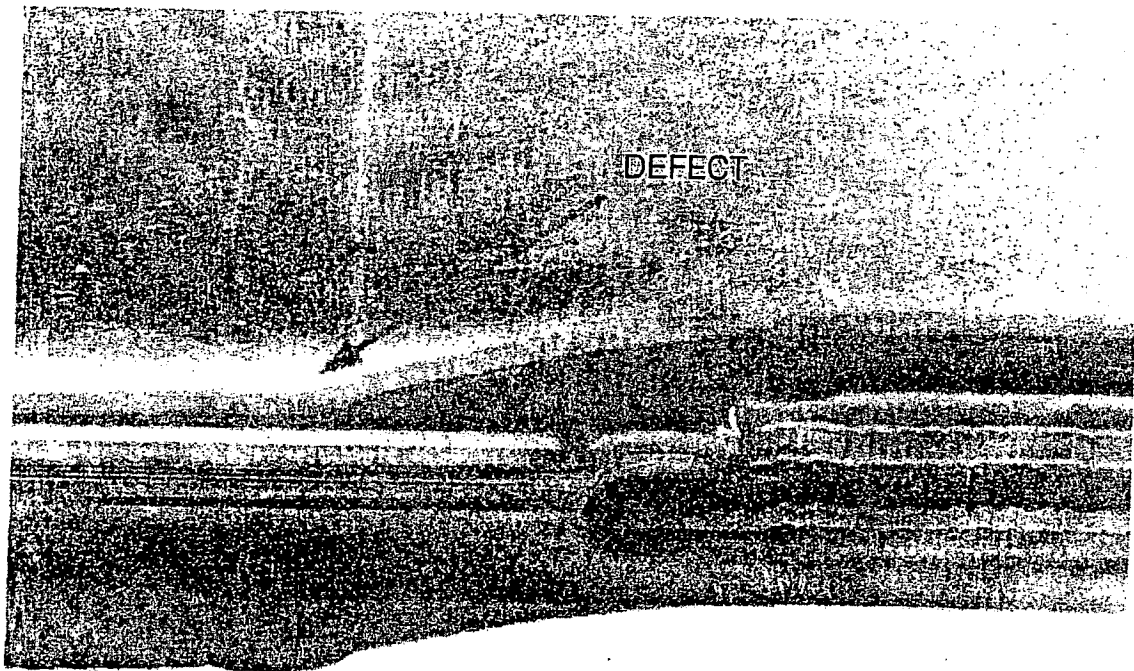

FIG. 7

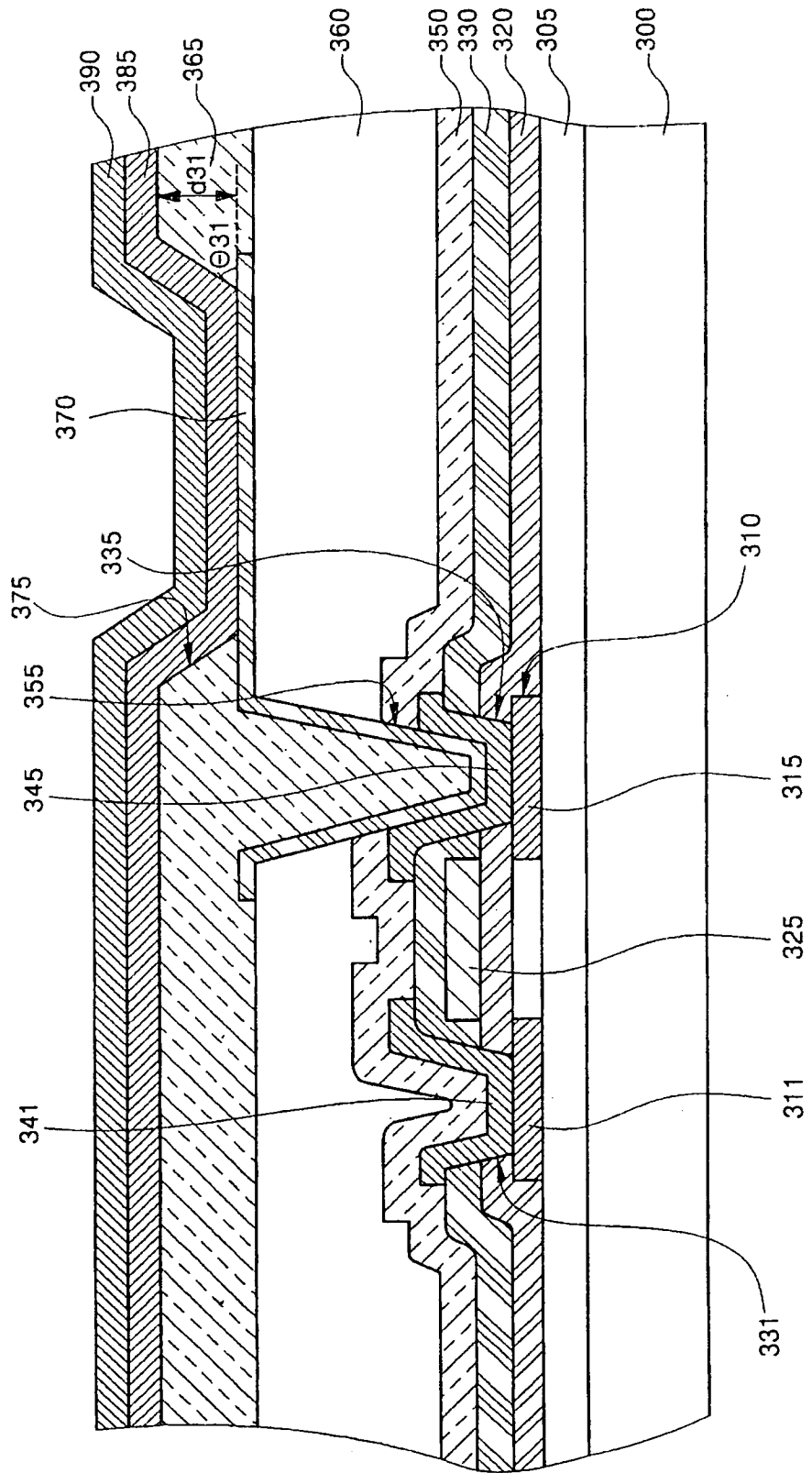

FIG. 8

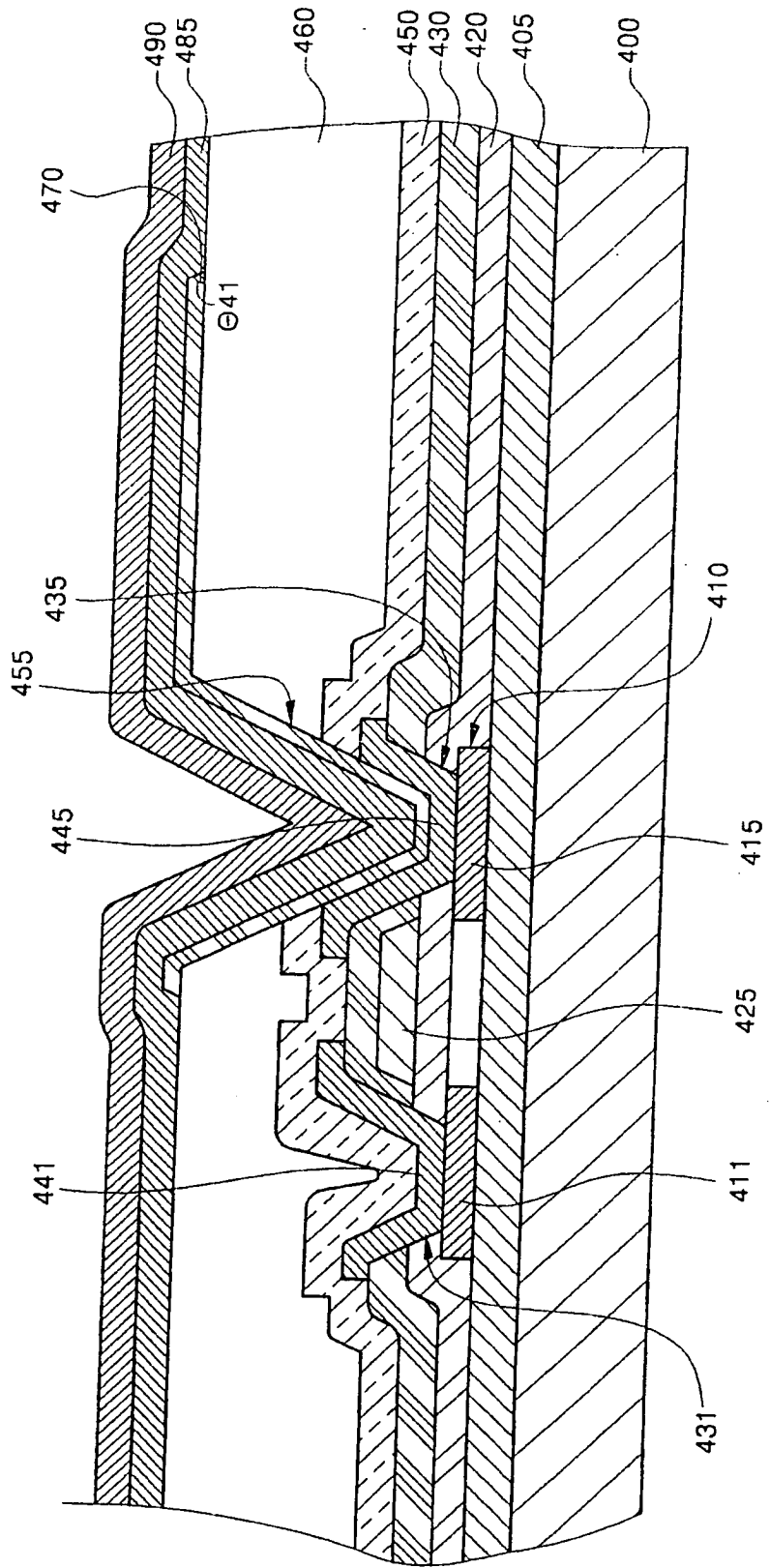

FIG. 9

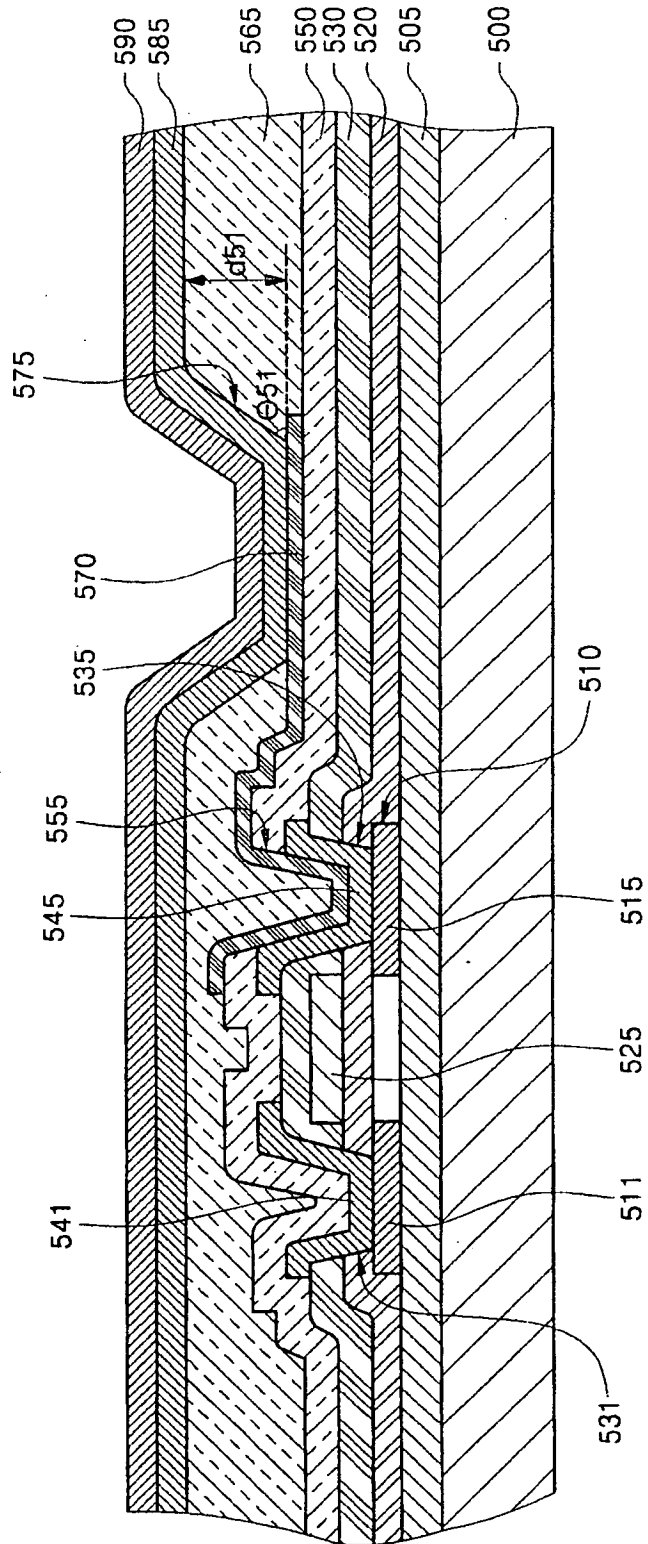
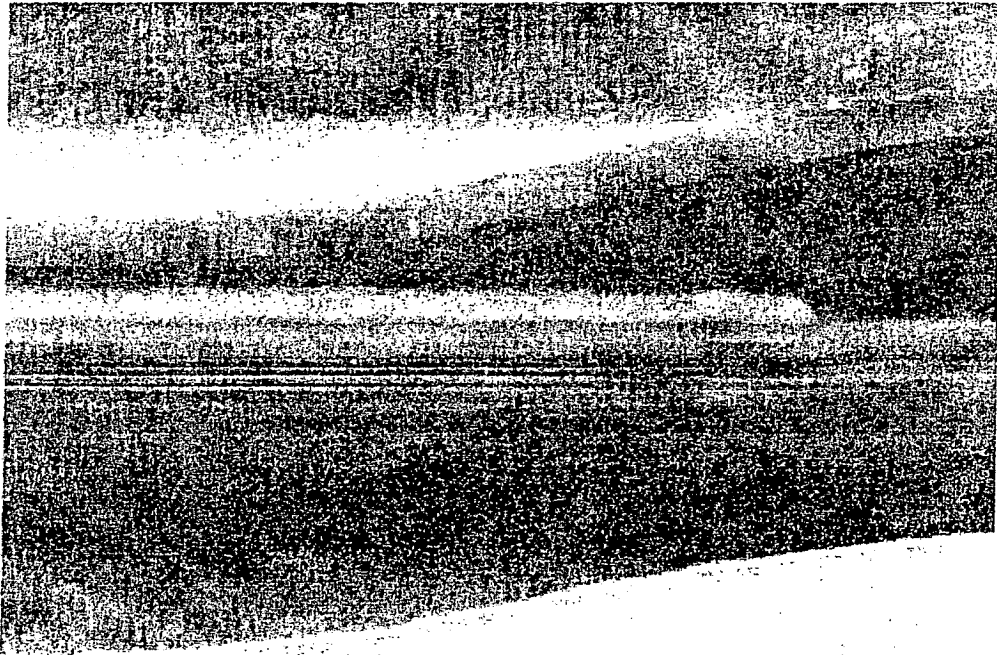



FIG. 11



**REFERENCES CITED IN THE DESCRIPTION**

*This list of references cited by the applicant is for the reader's convenience only. It does not form part of the European patent document. Even though great care has been taken in compiling the references, errors or omissions cannot be excluded and the EPO disclaims all liability in this regard.*

**Patent documents cited in the description**

- US 6246179 B [0006]
- EP 1315309 A2 [0016]
- US 20030151358 A1 [0016]
- EP 1063704 A2 [0016]
- US 20020063515 A1 [0017]
- US 20030209976 A [0017]

专利名称(译)	有机发光显示器		
公开(公告)号	<a href="#">EP1919007B1</a>	公开(公告)日	2012-06-20
申请号	EP2008151027	申请日	2004-11-25
[标]申请(专利权)人(译)	三星斯笛爱股份有限公司		
申请(专利权)人(译)	三星SDI CO. , LTD.		
当前申请(专利权)人(译)	三星移动显示器有限公司.		
[标]发明人	KIM MU HYUN KANG TAE MIN C O SAMSUNG SDI CO LTD		
发明人	KIM, MU-HYUN SONG, MYUNG-WON C/O SAMSUNG SDI CO, LTD. KANG, TAE-MIN C/O SAMSUNG SDI CO., LTD. LEE, SEONG-TAEK C/O SAMSUNG SDI CO.,LTD. CHO, YU-SUNG C/O SAMSUNG SDI CO.,LTD.		
IPC分类号	H01L27/32 H01L51/00 H01L51/50 G09F9/30 H05B33/22		
CPC分类号	H01L27/3246 H01L27/1248 H01L27/3248 H01L27/3258 H01L51/0013 H01L51/5206 H01L51/5221 H01L2251/5315 H01L2251/5323 H01L2251/558		
代理机构(译)	hengelhaupt , Jürgen		
优先权	1020030087789 2003-11-29 KR		
其他公开文献	EP1919007A2 EP1919007A3		
外部链接	<a href="#">Espacenet</a>		

摘要(译)

一种有机发光显示器，其构造有具有绝缘基板的TFT基板和至少具有源电极和漏电极的TFT，形成在TFT基板上并连接到源/漏电极之一的下电极，绝缘层，具有暴露下电极的一部分的开口，形成在下电极和绝缘层的暴露部分上的有机薄膜层，以及形成在有机薄膜层上的上电极，其中绝缘层具有在开口的边缘处具有小于40°的锥角，并且在下电极和有机薄膜层之间形成小于或等于3,000的台阶。有机发光显示器可以防止设备故障。

FIG. 1

