



(11) **EP 2 293 275 A1**

(12) **EUROPEAN PATENT APPLICATION**

(43) Date of publication:
09.03.2011 Bulletin 2011/10

(51) Int Cl.:
G09G 3/32^(2006.01) H01L 27/32^(2006.01)

(21) Application number: **09180882.4**

(22) Date of filing: **29.12.2009**

(84) Designated Contracting States:
AT BE BG CH CY CZ DE DK EE ES FI FR GB GR HR HU IE IS IT LI LT LU LV MC MK MT NL NO PL PT RO SE SI SK SM TR
Designated Extension States:
AL BA RS

(72) Inventors:
• **Tsai, Tsung-Tin Hsin-Chu (TW)**
• **Chang, Lee-Hsun Hsin-Chu (TW)**

(30) Priority: **01.09.2009 US 584221**

(74) Representative: **Lang, Christian et al LangRaible GbR Patent- und Rechtsanwälte Rosenheimerstrasse 139 81671 München (DE)**

(71) Applicant: **AU Optronics Corporation Hsin-Chu (TW)**

(54) **Pixel driving circuit for light emitting display panel**

(57) A display panel has a plurality of OLED pixels arranged in rows and columns. The pixel driving circuit has two or more current paths through a plurality of switching elements for providing the necessary current to the OLEDs in a pixel. The control end of each switching element is connected to the control end of the other switching elements, but each switching element has a

separate power source which can be separately adjustable. In some embodiments, in a pixel or sub-pixel, one switching element is located at one end and one switching element is located at the other end of a pixel length, and each pixel is adjacent to a first power source line and a second power source line along the pixel length for separately providing the electrical power to two switching elements.

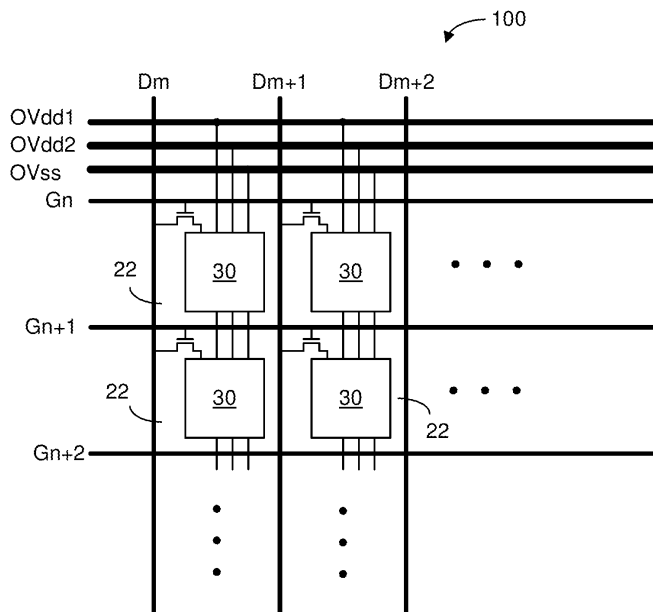

FIG. 3

EP 2 293 275 A1

DescriptionField of the Invention

[0001] The present invention relates generally to a display panel having a plurality of pixels made of light-emitting diodes and, more particularly, to a circuit for driving the pixels.

Background of the Invention

[0002] Light-emitting devices, such as organic light-emitting diodes (OLEDs), have been used in an active-matrix OLED (AMOLED) display. An active-matrix OLED (AMOLED) display panel consists of a two dimensional array of OLED pixels deposited or integrated onto a thin-film transistor (TFT) array. A typical OLED display panel is shown in Figure 1. As shown, the display panel 1 has a plurality of pixels 10 arranged in rows and columns in a display area 100 driven by a data driver 200 and a gate driver 300. The data driver 200 is used to provide signals indicative of data on a data line to each of the columns and a gate driver 300 is used to provide a gate line signal to each of the rows. In a color OLED display panel, an image is generally presented in three colors: red (R), green (G) and blue (B). Each of the pixels 10 is typically divided into three color sub-pixels: red sub-pixel 20R, green sub-pixel 20G and blue sub-pixel 20B, as shown in Figure 2. A data line 221 is used to provide the data signal to the R sub-pixel in a column, a data line 222 is used to provide the data signal to the G sub-pixel in the same pixel column, and a data line 223 is used to provide the data signal to the B sub-pixel in the same pixel column. The data line 224 is used to provide the data signal to the R sub-pixel in the next pixel column. A gate line 231 is used to provide the gate line signal to all sub-pixels in a row and a gate line 232 is used to provide the gate line signal to all sub-pixels in the next row.

Summary of the Invention

[0003] The present invention provides a method and a pixel driving circuit in which two or more current paths through a plurality of switching elements are used to provide the necessary current to one or more OLEDs in a pixel. In particular, the control end of each switching element is connected to the control end of the other switching elements. According to the present invention, the gate terminal of one switching element is connected to the gate terminal of another switching element, whereas each switching element is connected to a different power source line. According to various embodiments of the present invention, the different source lines are separately connected to different power sources so that the current in each current path can be separately adjustable.

[0004] Thus, the first aspect of the present invention is a light-emitting display panel. The display panel comprises:

a plurality of pixels arranged in a plurality of rows and columns;

a plurality of data lines, each data line arranged to provide data signals to the pixels in a column;

a plurality of gate lines, each gate line arranged to provide scan signals to the pixels in a row, wherein each pixel comprises:

a control switching element having a first switching end arranged to receive data signals from a data line, a second switching end, and a control end arranged to receive a scan signal;
a first switching element comprising:

a first switching terminal arranged to receive electrical power for providing a first current in a first current path; a second switching terminal connected to a light-emitting component; and a control terminal connected to the second switching end of the control switching element; and

a second switching element comprising: a first switching terminal arranged to receive electrical power for providing a second current in a second current path; a second switching terminal connected to the light-emitting component; and a control terminal connected to the second switching end of the control switching element.

[0005] According to some embodiments, the light-emitting component comprises: a first light-emitting diode arranged to receive the first current from the first current path; and a second light-emitting diode arranged to receive the second current from the second current path.

[0006] According to various embodiments of the present invention, each pixel comprises:

a first capacitor connected between the first switching terminal and the control terminal of the first switching element, and a second capacitor connected between the switching terminal and the control terminal of the second switching element.

[0007] The first switching element is arranged to receive electrical power from a first power source and the second switching element is arranged to receive electrical power from a different second power source.

[0008] According to one embodiment of the present invention, each pixel comprises a pixel length, wherein the first switching element and the first light-emitting diode are located at a first end of the pixel length, and the second switching element and the second light-emitting diode are located at a second end of the pixel length. Each pixel is adjacent to a first power source line and a second power line along the pixel length, the first switching element arranged to receive electrical power from a first power source line and the second switching element

arranged to receive electrical power from a second power source line.

[0009] The second aspect of the present invention is a method for use in a light-emitting display panel, the light-emitting display panel comprising:

a plurality of pixels arranged in a plurality of rows and columns;

a plurality of data lines, each data line arranged to provide data signals to the pixels in a column;

a plurality of gate lines, each gate line arranged to provide scan signals to the pixels in a row, wherein each pixel comprises a light-emitting component, wherein each of the pixels comprises a control switching element having a first switching end arranged to receive data signals from a data line, a second switching end, and a control end arranged to receive a scan signal, and each of the pixels comprises a light emitting component, said method comprising:

disposing a first current path in said each of the pixels for providing a first current to the light emitting component, and

disposing a different second current path in said each of the pixels for providing a second current to the light emitting component,

controlling the first current in the first current path through a first switching element, and

controlling the second current in the second current path through a second switching element, the first switching element comprising:

a first switching terminal arranged to receive electrical power for providing the first current in the first current path, a second switching terminal connected to the light-emitting component, and a control terminal connected to the second switching end of the control switching element; and

the second switching element comprising: a first switching terminal arranged to receive electrical power for providing the second current in the second current path, a second switching terminal connected to the light-emitting component, and a control terminal connected to the second switching end of the control switching element.

[0010] According to various embodiments of the present invention, the light-emitting component comprises: a first light-emitting diode arranged to receive the first current from the first current path; and a second light-emitting diode arranged to receive the second current from the second current path. Each pixel comprises a pixel length, wherein the first switching element and the first light-emitting diode are located at a first end of the pixel length, and the second switching element and the second light-emitting diode are located at a second end of the pixel length.

[0011] The present invention will become apparent upon reading the description taken in conjunction with Figures 3 to 11.

5 Brief Description of the Invention

[0012]

Figure 1 shows a typical OLED display panel.

10 Figure 2 shows three color sub-pixels in a pixel in a typical OLED display panel.

Figure 3 shows a portion of the display area having a plurality of pixels, according to various embodiments of the present invention.

15 Figure 4 shows a pixel and its driving circuit, according to one embodiment of the present invention.

Figure 5 shows a pixel and its driving circuit, according to another embodiment of the present invention.

20 Figure 6 shows a pixel and its driving circuit, according to yet another embodiment of the present invention.

Figure 7 shows a pixel and its driving circuit, according to still another embodiment of the present invention.

25 Figure 8 shows a pixel and its driving circuit, according to a different embodiment of the present invention.

Figure 9 shows a pixel and its driving circuit, according to yet another embodiment of the present invention.

30 Figure 10 shows an exemplary layout of a pixel, according to the present invention.

Figure 11 shows another layout of a pixel, according to the present invention.

35 Detailed Description of the Invention

[0013] In a typical OLED display panel, a power source is used to provide a voltage to a plurality of pixels. A conductor is used to provide the voltage to each of the pixels as a drain voltage applied to a TFT which regulates the current through a connecting OLED. The conductor inherently has a resistance, causing a drop in the voltage in proportion to the current. The voltage drop can be substantial if the current is high. As a result, the brightness of the display may vary noticeably among the pixels, affecting the viewing quality of an OLED display panel.

40 **[0014]** The present invention provides a pixel driving circuit and a method for improving the viewing quality of the OLED display panel by reducing the voltage drop in the pixels. According to various embodiments of the present invention, the drain voltage applied to the switching elements in the OLED pixels comprises two or more separate lines OVdd1, OVdd2. If the source voltage line in each pixel is short, it is sufficient to use only one source voltage line OVss. For example, if the OLED is fabricated on a substrate where one end of the diode is in direct contact with an electrically conducting plane, the voltage

drop on the OVss side is negligible. However, it is also possible to use two or more OVss lines. As shown in Figure 3, each pixel 22 has a pixel area 30 and each pixel area 30 has two separate conductors connected to OVdd1 and OVdd2. Gn, Gn+1, ... are gate lines for providing gate line data and Dm, Dm+1, ... are data lines for providing data signal.

[0015] In one embodiment of the present invention, a pixel area 30 comprises two OLEDs, D1 and D2, separately connected to two TFTs, M1 and M2 to form two separate current paths (shown with current I1 and current I2). The gate terminals of M1 and M2 are connected together such that, in effect, the current paths are connected in parallel. Both M1 and M2 are p-type TFTs arranged to be switched on or off simultaneously by a switching element M3, which can be a TFT. One end of the TFT M3 is connected to a data line to receive a signal Vdata m and the gate terminal of M3 is connected to a gate line to receive a scan signal n. Each of the current I1 and current I2 has a storage capacitor C1, C2 connected to the switching element M3.

[0016] With two or more OLEDs in each OLED pixel, it is possible to reduce the current I1 and current I2 to achieve the brightness from one OLED with a higher current. As a result, the voltage drop in each of the current paths is smaller than the voltage drop if only one current path is used to produce light. For example, the current used in only one current path to produce light at a certain brightness level is I, then it is possible to use $I1 < I$ and $I2 < I$ to achieve the same brightness level. If the brightness of an OLED is proportional to the current, then $I = I1 + I2$.

[0017] In another embodiment of the present invention, one of the current regulating TFTs is a p-type TFT and the other is an n-type TFT as shown in Figure 5.

[0018] In yet another embodiment of the present invention, both M1 and M2 are n-type TFTs.

[0019] In the embodiments as shown in Figures 4 to 6, it is possible to put the anodes of both M1 and M2 in contact with an electrically conducting layer on a substrate where OVss is provided. As such, the voltage drop on the OVss side is substantially eliminated.

[0020] In a current path wherein an n-type TFT is used to regulate the current through the OLED, it is also possible to connect one switching end of the TFT to OVss, as shown in Figures 7 and 8. In this configuration, it would be advantageous to keep the connector between the source terminal of the TFT or TFTs to the OVss source very short so as to reduce the voltage drop on the OVss side.

[0021] It should be noted that, according to various embodiments of the present invention, the voltage drop on OVdd can be reduced by using two or more current paths to provide the current to an OLED on each of the current paths. It is possible to achieve a similar voltage-drop reduction by passing the currents from two or more current paths to one OLED, as shown in Figure 9.

[0022] In summary, the present invention provides a

method and a pixel driving circuit in which two or more current paths, through a plurality of switching elements, are used to provide the necessary current to one or more OLEDs in a pixel. In particular, the control end of each switching element is connected to the control end of the other switching elements. For example, as shown in Figures 4 to 6, the gate terminal of TFT M1 is connected to the gate terminal of TFT M2. According to various embodiments of the present invention, each switching element has a separate power source OVdd so that the power sources can be separately adjustable. Furthermore, with separate power sources, it is possible to arrange OVdd1 and OVdd2 to be provided from different directions. For example, each of the pixels 30 as shown in Figure 4 represents a color sub-pixel R, B or G. The color sub-pixels can be arranged side-by-side, with two power-source lines OVdd1, OVdd2 located between two adjacent color sub-pixels such as B and G. In each of the sub-pixels R, B and G, the TFT M1 is located at one end of the sub-pixel and the other TFT M2 is located at the other end. As shown in Figure 10, the sub-pixel 30 has a width separated by a data line (Vdata) and one of power-source lines OVdd1 and OVdd2, and a length separated by a scan line and a source-supply line OVDD. Along the length the sub-pixel has a first end a second end. The first end has a first OLED area 32 and the second end has a second OLED area 34. At the first end, TFT M1 is used to provide the current path to OLED D1 in the first OLED area 32. At the second end, TFT M2 is used to provide the current path to OLED D2 in the second OLED area 34. As such, the power-source line OVdd1 provides a source voltage to TFT M1 from the first end and the power-source line OVdd2 provides a source voltage to TFT M2 from the second end. Since each TFT is connected to a separate power-source line at a short distance, the voltage drop of OVdd1 and OVdd2 can be reduced.

[0023] In other embodiments, the power sources that provide electrical power to M1 and M2 are connected to the same power source OVDD, as shown in Figure 11. Thus, the power source lines OVdd1 and OVdd2 as shown in Figure 10 can be combined into a power source line OVdd.

[0024] Thus, although the present invention has been described with respect to one or more embodiments thereof, it will be understood by those skilled in the art that the foregoing and various other changes, omissions and deviations in the form and detail thereof may be made without departing from the scope of this invention.

Claims

1. A light-emitting display panel, comprising:

- a plurality of pixels arranged in a plurality of rows and columns;
- a plurality of data lines, each data line arranged

to provide data signals to the pixels in a column; a plurality of gate lines, each gate line arranged to provide scan signals to the pixels in a row, wherein each pixel comprises:

a control switching element having a first switching end arranged to receive data signals from a data line, a second switching end, and a control end arranged to receive a scan signal; a first switching element comprising:

a first switching terminal arranged to receive electrical power for providing a first current in a first current path; a second switching terminal connected to a light-emitting component; and

a control terminal connected to the second switching end of the control switching element; and a second switching element comprising:

a first switching terminal arranged to receive electrical power for providing a second current in a second current path; a second switching terminal connected to the light-emitting component; and

a control terminal connected to the second switching end of the control switching element.

2. The display panel of claim 1, wherein the light-emitting component comprises:

a first light-emitting diode arranged to receive the first current from the first current path; and a second light-emitting diode arranged to receive the second current from the second current path.

3. The display panel of claim 1, wherein each of the first switching element and the second switching element comprises a p-type transistor.

4. The display panel of claim 1, wherein each of the first switching element and the second switching element comprises an n-type transistor.

5. The display panel of claim 1, wherein the first switching element comprises a p-type transistor and the second switching element comprises an n-type transistor.

6. The display panel of claim 1, wherein each pixel further comprises:

a capacitor connected between the first switching terminal and the control terminal of the first

switching element.

7. The display panel of claim 1, wherein the first switching element is arranged to receive electrical power from a first power source and the second switching element is arranged to receive electrical power from a different second power source.

8. The display panel of claim 2, wherein each pixel comprises a pixel length, wherein the first switching element and the first light-emitting diode are located at a first end of the pixel length, and the second switching element and the second light-emitting diode are located at a second end of the pixel length.

9. The display panel of claim 8, wherein each pixel is adjacent to a first power source line and a second power source line along the pixel length, the first switching element arranged to receive electrical power from the first power source line and the second switching element arranged to receive electrical power from the second power source line.

10. The display panel of claim 1, wherein each pixel comprises a color sub-pixel.

11. A method for use in a light-emitting display panel, the light-emitting display panel comprising:

a plurality of pixels arranged in a plurality of rows and columns;

a plurality of data lines, each data line arranged to provide data signals to the pixels in a column; a plurality of gate lines, each gate line arranged to provide scan signals to the pixels in a row, wherein each pixel comprises a light-emitting component, wherein each of the pixels comprises a control switching element having a first switching end arranged to receive data signals from a data line, a second switching end, and a control end arranged to receive a scan signal, and each of the pixels comprises a light emitting component, said method comprising:

disposing a first current path in said each of the pixels for providing a first current to the light emitting component, and

disposing a different second current path in said each of the pixels for providing a second current to the light emitting component,

controlling the first current in the first current path through a first switching element, and controlling the second current in the second current path through a second switching element, the first switching element comprising:

a first switching terminal arranged to receive electrical power for providing the first current in the first current path;

a second switching terminal connected to the light-emitting component; and

a control terminal connected to the second switching end of the control switching element; and
5
the second switching element comprising:

a first switching terminal arranged to receive electrical power for providing the second current in the second current path; 10
a second switching terminal connected to the light-emitting component; and

a control terminal connected to the second switching end of the control switching element. 15

12. The method of claim 11, wherein the light-emitting component comprises: 20

a first light-emitting diode arranged to receive the first current from the first current path; and
a second light-emitting diode arranged to receive the second current from the second current path. 25

13. The method of claim 12, wherein each pixel comprises a pixel length, wherein the first switching element and the first light-emitting diode are located at a first end of the pixel length, and the second switching element and the second light-emitting diode are located at a second end of the pixel length. 30

14. The method of claim 13, further comprising: 35

arranging a first power source line and a second power line along the pixel length such that each pixel is adjacent to both the first power source line and the second power source line;
arranging the first switching element for receiving electrical power from the first power source line and the second switching element for receiving electrical power from the second power source line. 40
45

50

55

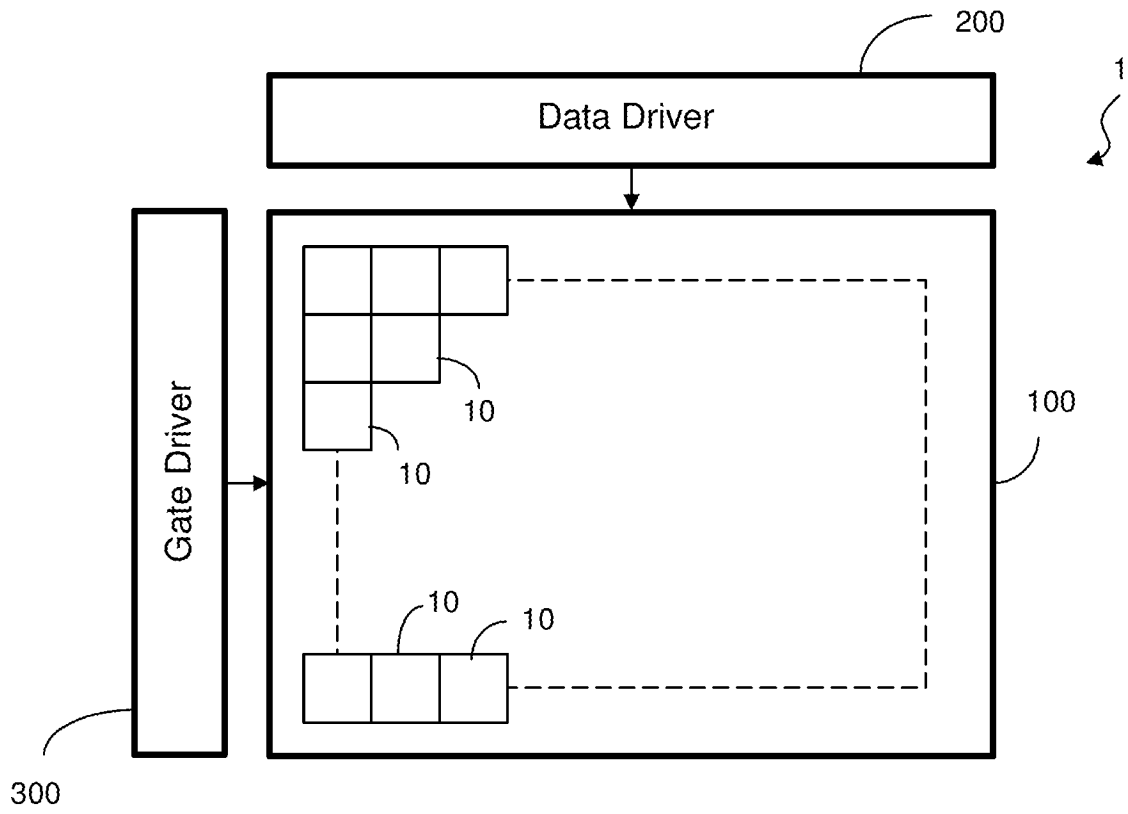
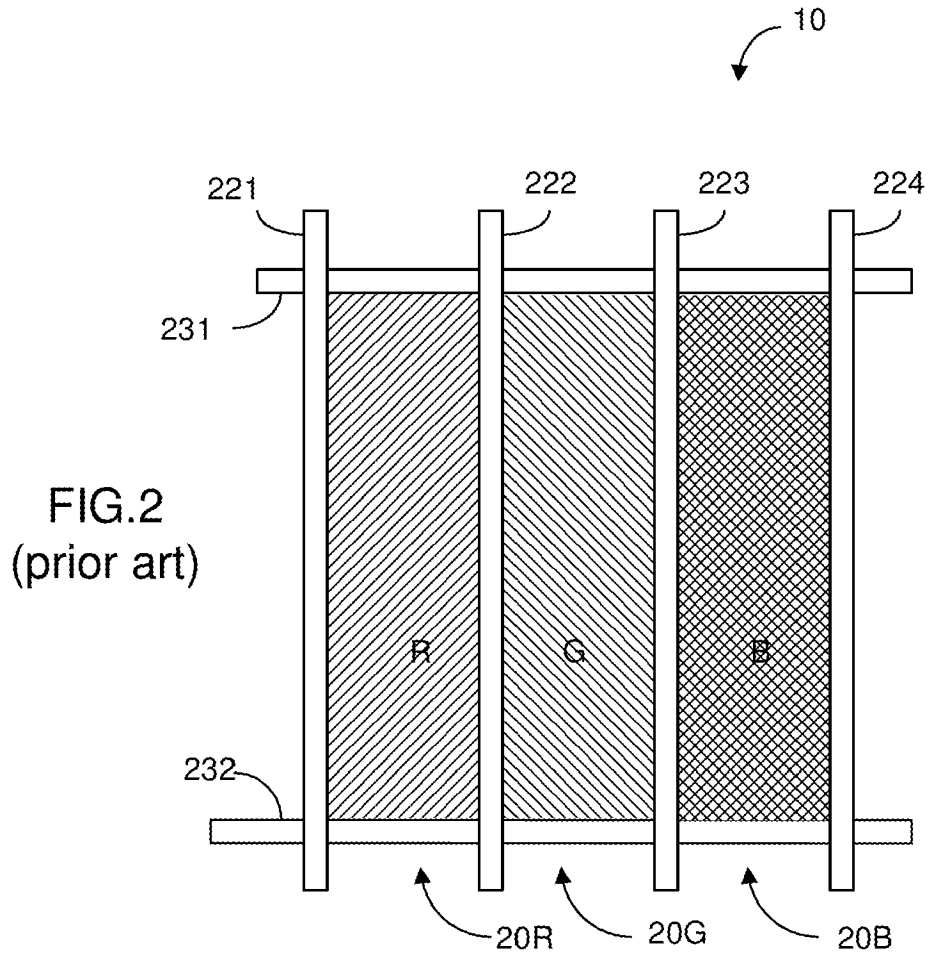

FIG. 1
(prior art)



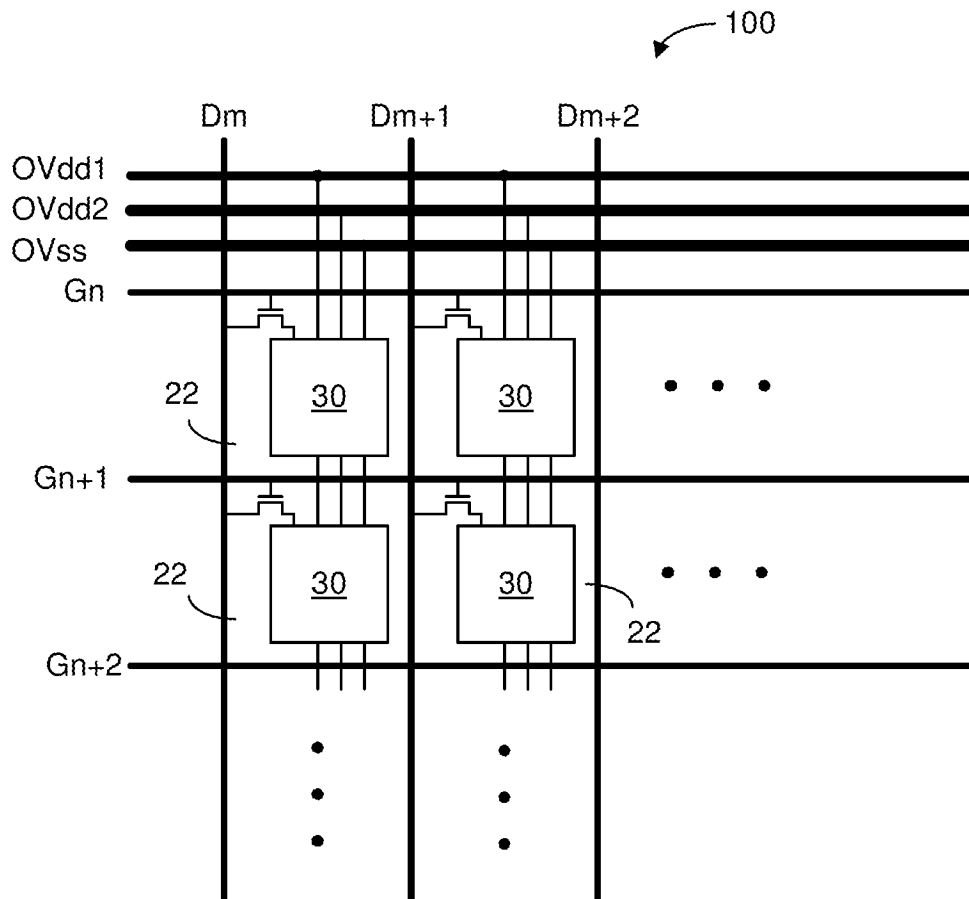

FIG. 3

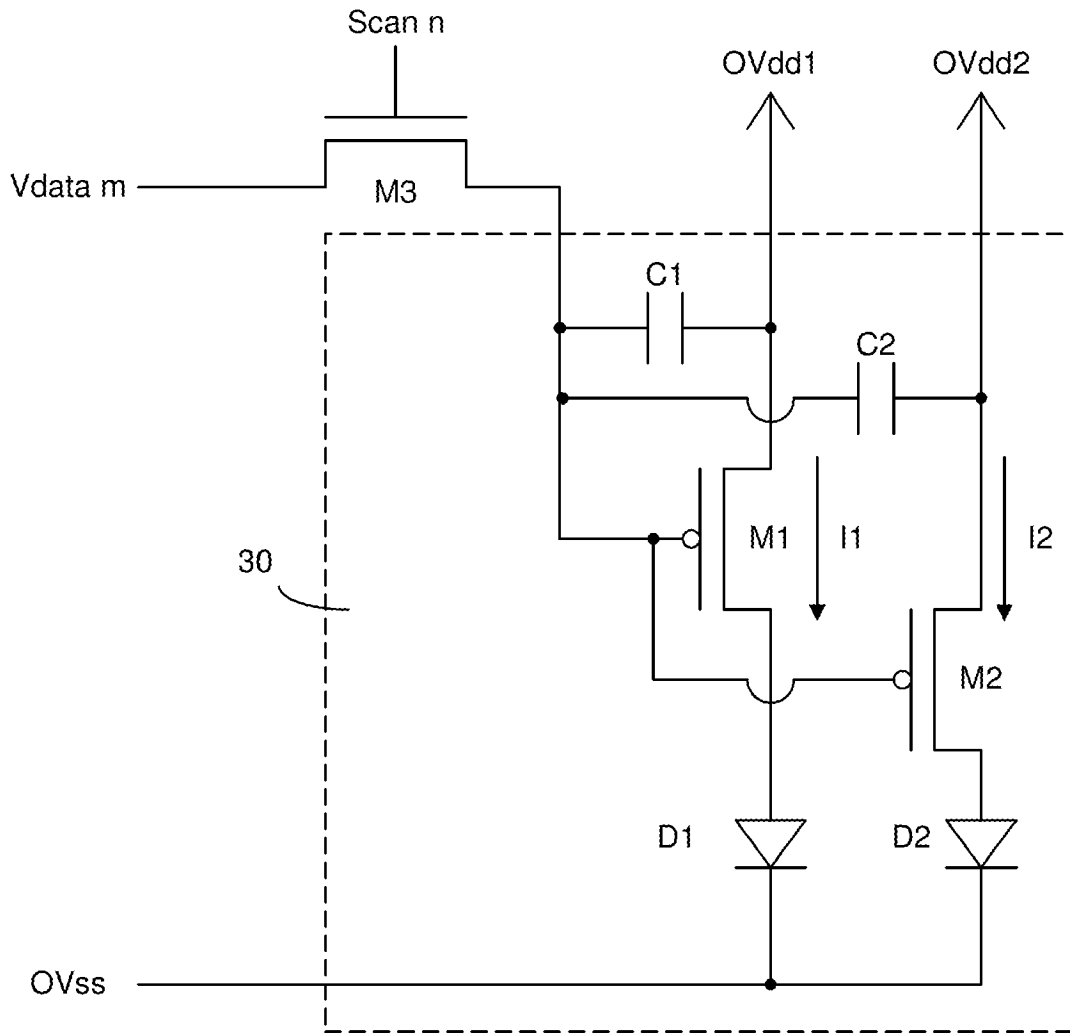

FIG. 4

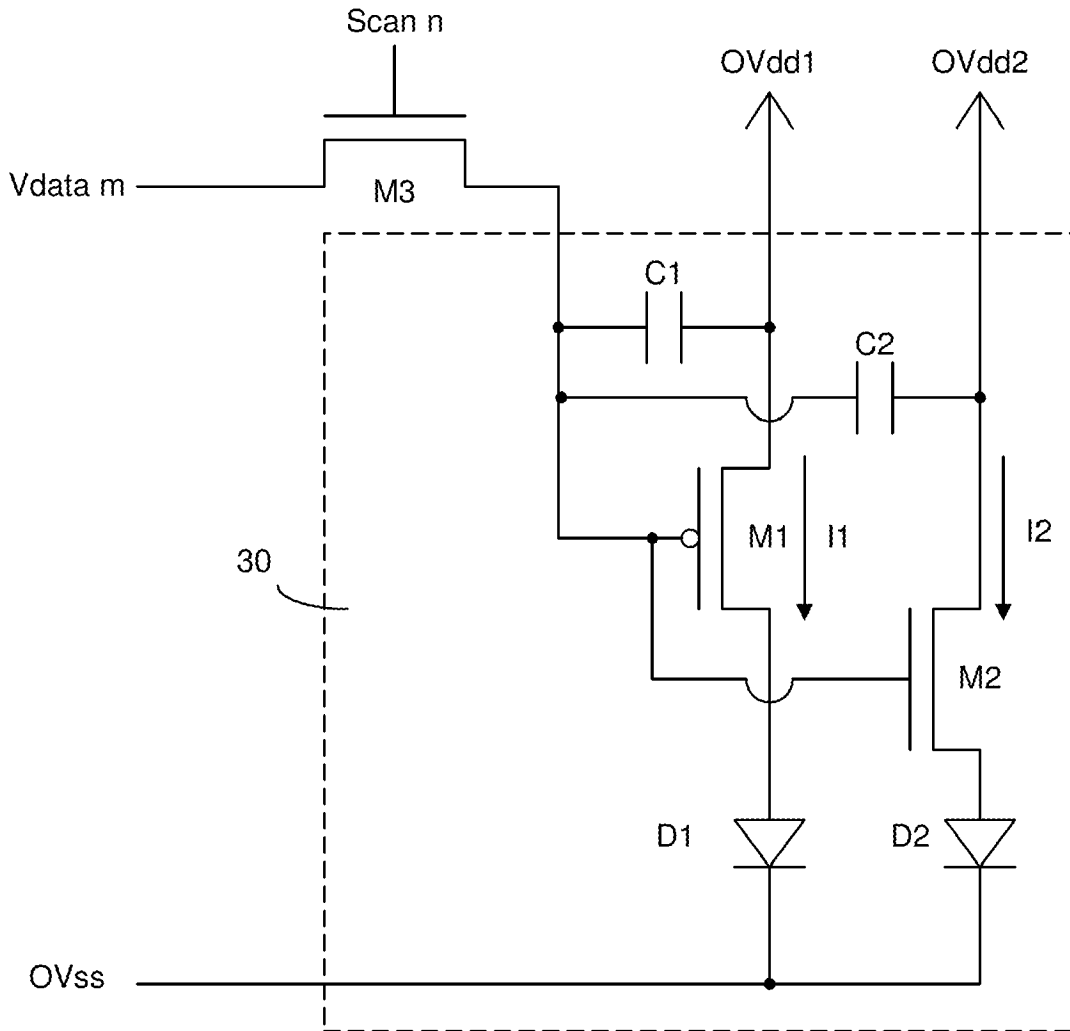

FIG. 5

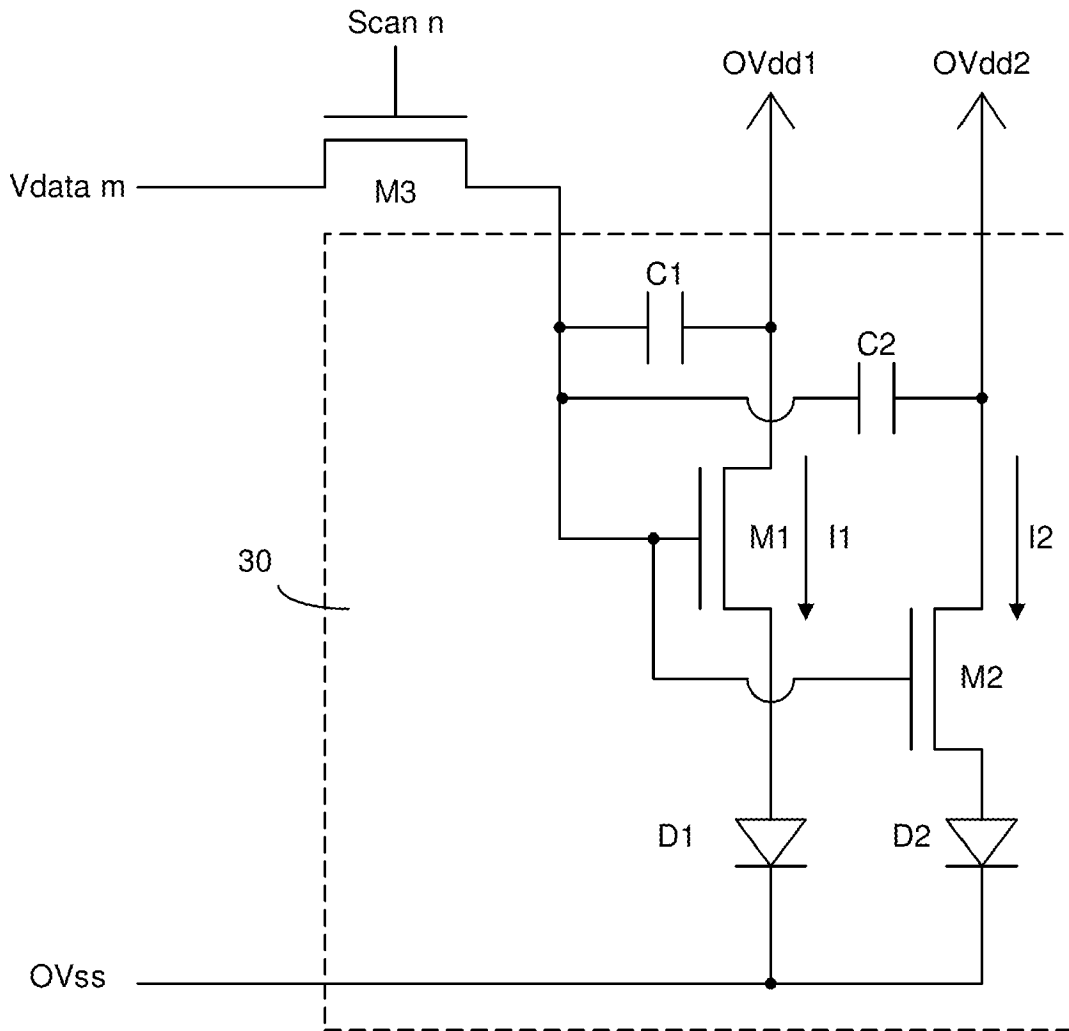

FIG. 6

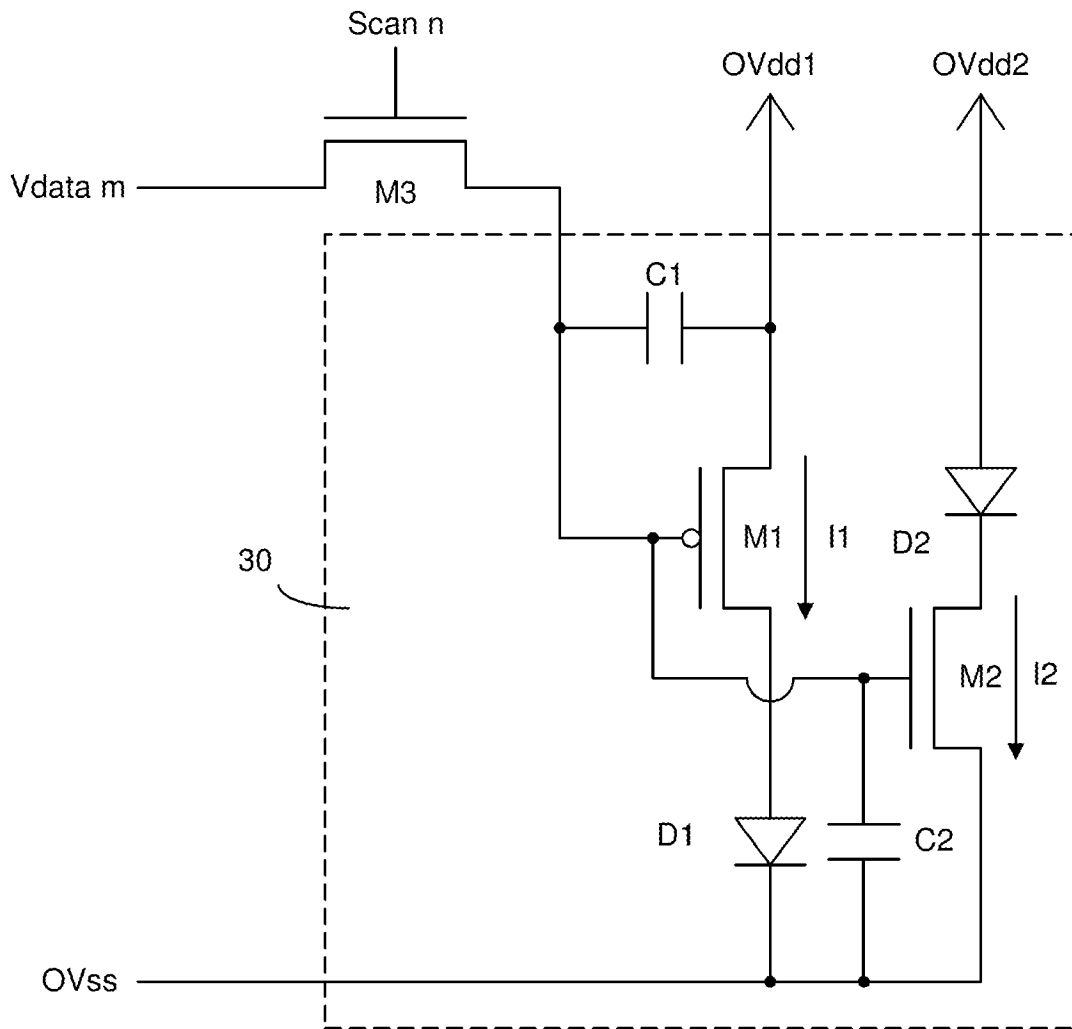

FIG. 7

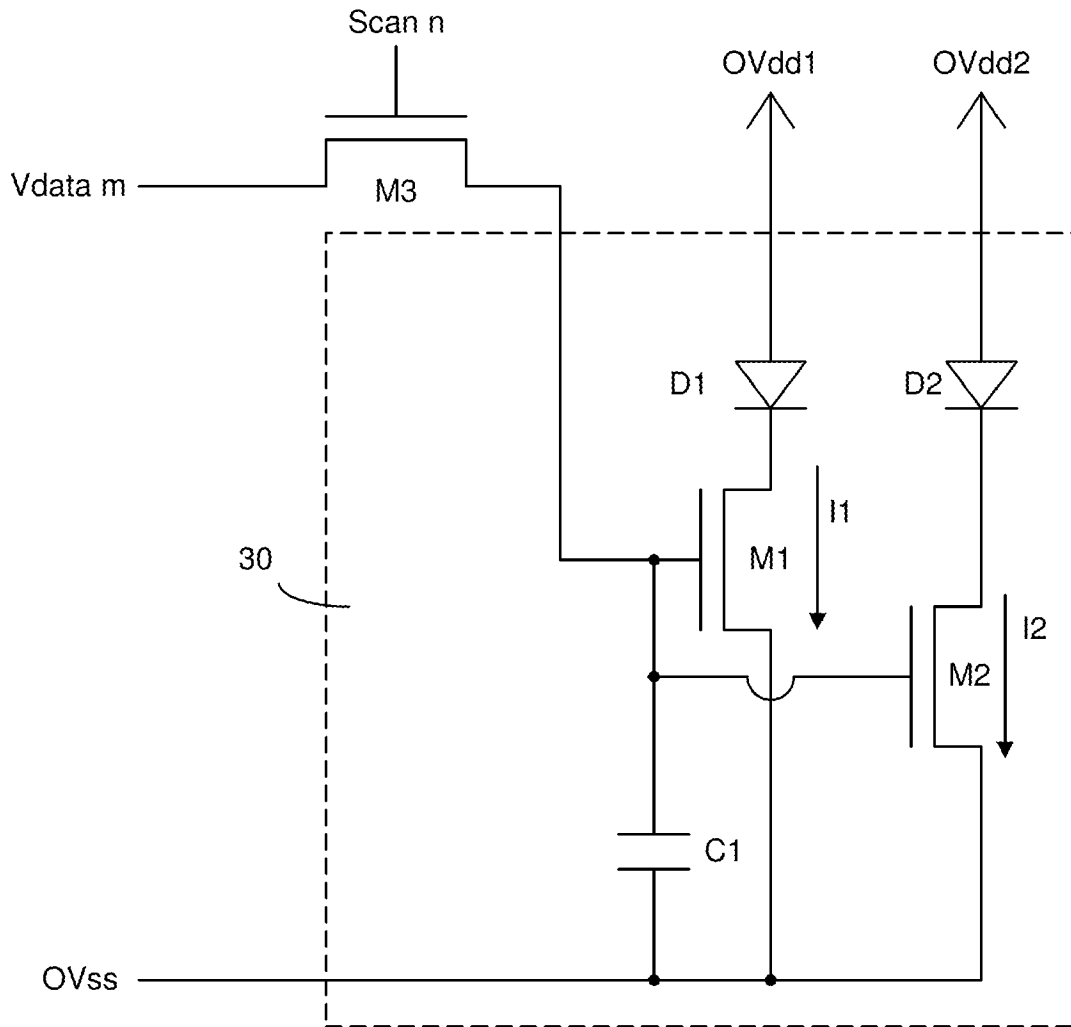

FIG. 8

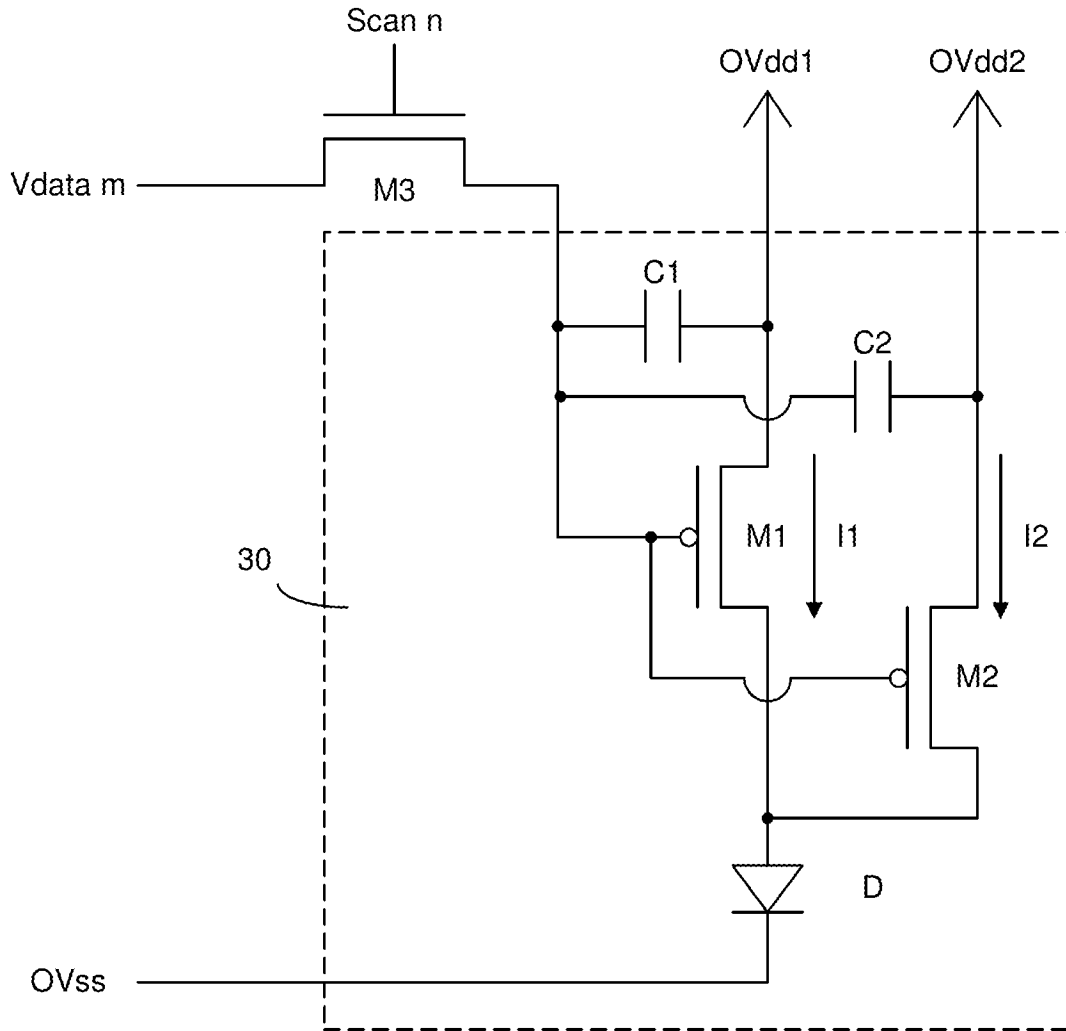

FIG. 9

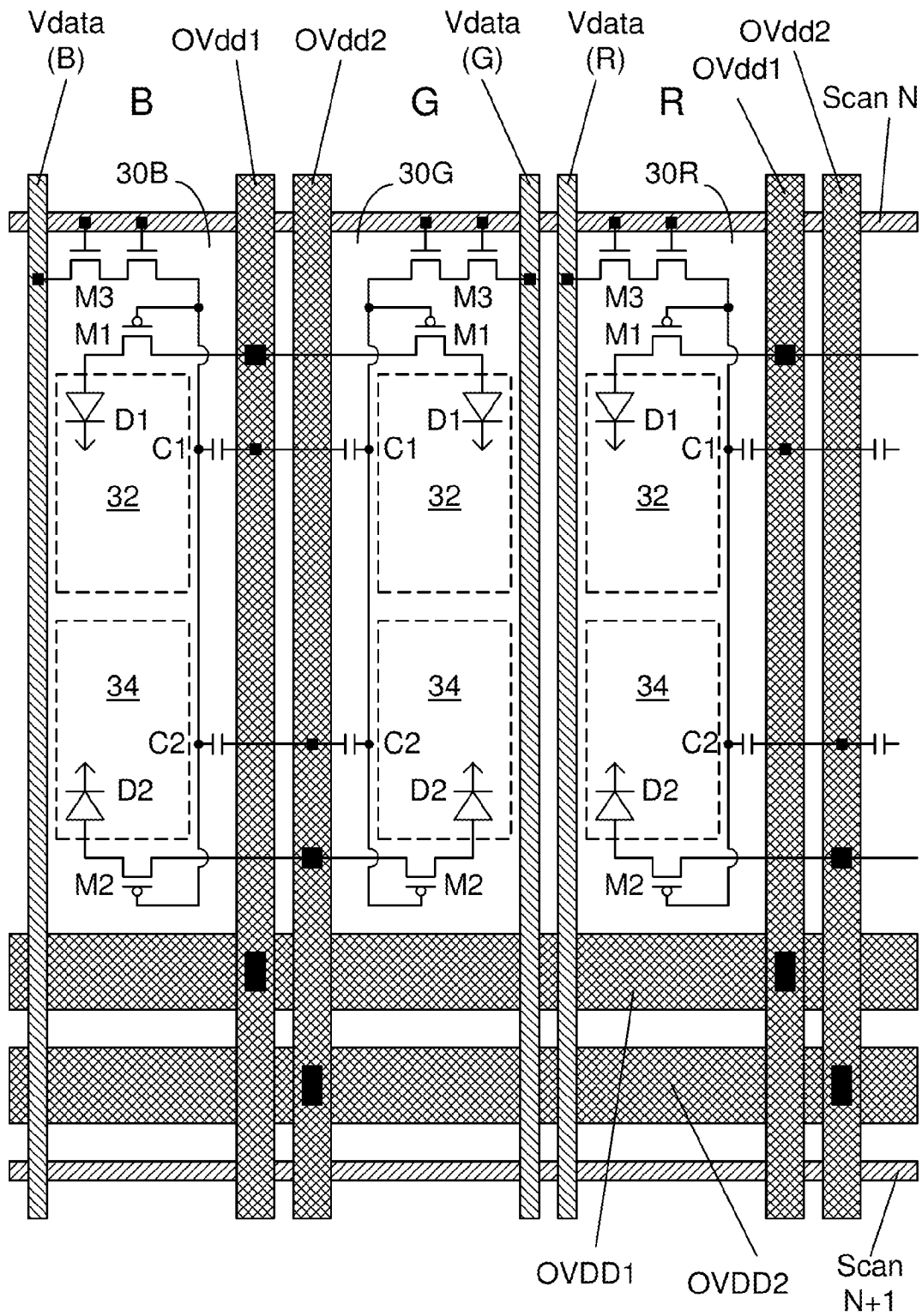

FIG. 10



Europäisches
Patentamt
European
Patent Office
Office européen
des brevets

EUROPEAN SEARCH REPORT

Application Number
EP 09 18 0882

DOCUMENTS CONSIDERED TO BE RELEVANT				
Category	Citation of document with indication, where appropriate, of relevant passages	Relevant to claim	CLASSIFICATION OF THE APPLICATION (IPC)	
X	US 2001/043168 A1 (KOYAMA JUN [JP] ET AL) 22 November 2001 (2001-11-22) * paragraphs [0049], [0050], [0149], [0150], [0167] - [0170], [175], [217] - [0218], [0222], [0449], [0450]; figures 5,8,9,10,40,41,42 *	1-14	INV. G09G3/32 H01L27/32	
X	US 2004/227707 A1 (INUKAI KAZUTAKA [JP]) 18 November 2004 (2004-11-18) * paragraphs [0073] - [0082], [0115], [0116], [0185] - [0191], [0285], [0314], [0316], [0317], [0362], [0364]; figures 2,3,8,15a,15b,21 *	1-14		
X	US 2004/004443 A1 (PARK JAE YONG [KR] ET AL) 8 January 2004 (2004-01-08) * paragraphs [0107] - [0120]; figures 8,9,10 *	1-14		
X	EP 1 193 741 A2 (SANYO ELECTRIC CO [JP]) 3 April 2002 (2002-04-03) * paragraphs [0023] - [0027], [0055]; figures 1,7 *	1-14		TECHNICAL FIELDS SEARCHED (IPC)
A	US 2007/008269 A1 (KIMURA HAJIME [JP]) 11 January 2007 (2007-01-11) * paragraphs [0018], [0019]; figures 14a,14b *	2,8,12, 13		G09G H01L
A	US 6 522 079 B1 (YAMADA TSUTOMU [JP]) 18 February 2003 (2003-02-18) * column 1, lines 20-33; figures 3,5a,5b,5c * * column 3, lines 3-19 * * column 8, line 14 - column 9, line 62 *	7,9,14		
The present search report has been drawn up for all claims				
Place of search The Hague		Date of completion of the search 13 April 2010	Examiner Vázquez del Real, S	
CATEGORY OF CITED DOCUMENTS X : particularly relevant if taken alone Y : particularly relevant if combined with another document of the same category A : technological background O : non-written disclosure P : intermediate document		T : theory or principle underlying the invention E : earlier patent document, but published on, or after the filing date D : document cited in the application L : document cited for other reasons & : member of the same patent family, corresponding document		

1

EPO FORM 1503 03.82 (P04C01)

ANNEX TO THE EUROPEAN SEARCH REPORT
ON EUROPEAN PATENT APPLICATION NO.

EP 09 18 0882

This annex lists the patent family members relating to the patent documents cited in the above-mentioned European search report. The members are as contained in the European Patent Office EDP file on
The European Patent Office is in no way liable for these particulars which are merely given for the purpose of information.

13-04-2010

Patent document cited in search report	Publication date	Patent family member(s)	Publication date
US 2001043168 A1	22-11-2001	KR 20060063837 A	12-06-2006
		KR 20070092694 A	13-09-2007
		TW 554637 B	21-09-2003
		TW 554638 B	21-09-2003

US 2004227707 A1	18-11-2004	NONE	

US 2004004443 A1	08-01-2004	CN 1475983 A	18-02-2004
		JP 4145737 B2	03-09-2008
		JP 2004094211 A	25-03-2004
		KR 20040005163 A	16-01-2004

EP 1193741 A2	03-04-2002	CN 1346153 A	24-04-2002
		JP 2002176063 A	21-06-2002
		KR 20020025809 A	04-04-2002
		TW 529108 B	21-04-2003
		US 2002070381 A1	13-06-2002

US 2007008269 A1	11-01-2007	US 2009309823 A1	17-12-2009

US 6522079 B1	18-02-2003	JP 2001109405 A	20-04-2001
		KR 20010050783 A	25-06-2001
		TW 577240 B	21-02-2004

专利名称(译)	用于发光显示面板的像素驱动电路		
公开(公告)号	EP2293275A1	公开(公告)日	2011-03-09
申请号	EP2009180882	申请日	2009-12-29
[标]申请(专利权)人(译)	友达光电股份有限公司		
申请(专利权)人(译)	友达光电股份有限公司		
当前申请(专利权)人(译)	友达光电股份有限公司		
[标]发明人	TSAI TSUNG TIN CHANG LEE HSUN		
发明人	TSAI, TSUNG-TIN CHANG, LEE-HSUN		
IPC分类号	G09G3/32 H01L27/32		
CPC分类号	G09G3/3233 G09G2300/0426 G09G2300/0439 G09G2300/0465 G09G2300/0842 G09G2300/0852 G09G2320/0223 G09G2320/0233 G09G2330/02 H01L27/326		
代理机构(译)	LANG, CHRISTIAN		
优先权	12/584221 2009-09-01 US		
外部链接	Espacenet		

摘要(译)

显示面板具有以行和列布置的多个OLED像素。像素驱动电路具有通过多个开关元件的两个或更多个电流路径，用于向像素中的OLED提供必要的电流。每个开关元件的控制端连接到其他开关元件的控制端，但每个开关元件具有可单独调节的单独电源。在一些实施例中，在像素或子像素中，一个开关元件位于一端，一个开关元件位于像素长度的另一端，并且每个像素与第一电源线 and 第二电源相邻沿像素长度的源极线用于分别向两个开关元件提供电功率。

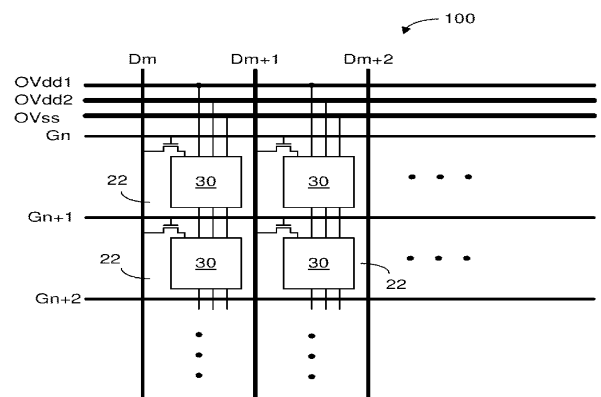

FIG. 3