

(19)
(12)

(KR)
(B1)

(51) 。 Int. Cl. 7
G02F 1/1335

(45)
(11)
(24)

2002 08 28
10 - 0350596
2002 08 16

(21) 10 - 2000 - 0005026
(22) 2000 02 02

(65) 2000 - 0057869
(43) 2000 09 25

(30) 1999 - 026570 1999 02 03 (JP)

(73) 가 가 5 7 1

(72) 5 7 1 가 가
5 7 1 가 가

(74)

:

(54)

가 ,
가 .
, P 가 . S .
, , .

4

, S , P , , , , , , ,

1

2

3

4 1

5 1

6 1

7 2

<

1a, 1b :

2 :

3 :

4 :

5 :

6 :

7 :

8 : P

9 : S

10 :

11 :

1 , 1 , (105)가 , (backlight, 107)
 (101b) (102) (107) (105)
 (105) (102) , (101a) (105)
 (102)

(105) (105)
 , (107) 가 , (105) (101b)
 , (101b) (101b) , (107) (107)
 1/2 (102) (107) , (107)
 가 ,

가
 , 9 - 326205 2
 9 - 326205 3 9
 - 274109

2 9 - 326205 (201),
 (201) (221) (202), (202)
 230 (231), (202) (
 (201) (202) (230)
 (231) (221) (202)
 (230) (230)
 (202)

2
 가 , ,

3 9 - 274109 ,
 (320), (330), (340), (350)
 (320) (310) (330) (320) (320)
 (340) (320)
 (350) , (310)
 가 ,

(320) (320) (310) (320) Brewster B (330)
 (321) , (322) (321) (331) (330) (320)
 (332) (321)

(310) , (321 331)
 S (321 331) P
 P (311) S (312)

(340) (320) (321)
 (323) (320) (
 (330)) (323 321)

(340) (330) (310) (
 320) (334 324) 1/2 (340) , (321)

(340) S P (313) 1/2 (321)
 S 1/2 (340)

(350) (320) (322)
 2가 (350) (32
 2) P , (350) (3
 51) P , (350) (350) P P

(310) Brewster B
 (321) P (311) S (312)
 S (312) P (313) (340) 1/2 P (350)
 P (311) P (313) (350) (350)

3 , 가
 (321) 1/2 1/2 (340) (310) (332) ,
 (321) 1/2 가 (350) , 가

가

가

가

가

가

가

2가

가

가

가

가

가

가

가

가

,

가

(1)

4 1

4 (1b) (6) (2) (1a) (2) (5) (1b) (2) (5) (5) (4) (3) (4) (6) (4) (3) (2)

(10) (11) (3) (4) (5) (6) (5) (6)

(6) (5) (2) (6) (6)

P

5 (5) 4 5 가 (4) (3) (4) (4) (10) (4) (4) (3) (4) (3) (4) (4) (3) (4) (3) (11)

2

(3) (4) X , X (5) Z (5) (

4) X Y , N_{X1} , Y (5) N_{Y1} , Z N_{Z1} , N_{X1} N_Y (

$1 = N_{Z1}$ 가 (3) N_{X2} , Y (3) N_{Y2} , Z N_{Z2} , N_{X1} N_{X2} (= N_{Y2} =

N_{Z2}) N_{Y1} = N_{Z1} 가 (5) (1b)

3 (6) (5) 3 (6)

6 (6) (7) (4) (5)

(7) Y Z (7) (4) (11) (11)

(5) N_{Y1} / N_{Y2} , P (8) N_{Y1} N_{Y2} , P (8) N_{Y1} N_{Y2}

N_{Y1} / N_{Y2} , P (8) (2) 가 , P (8) , N_{Y1} / N_{Y2}

Y2 1 , (11) P 가 가 ,

N_{Y1} / N_{Y2} 0.75 0.95 . P (8) 가 가

(6) (5) (11) P (6)

(4) (11) P (6)

= (90 - arctan (N_{Y1} / N_{Y2})) × 2

(3) (4) 30 300μm , (2)

(moire) 가 50μm

(11) (7) X Z S (9)

N_{X1} N_{X2} 6 (11) S (9) N_{X1} / N_{X2} 1.0 S

3 (9) (6) (2) (6)

(6) (1b) S (5) (6)

11) (2) , P (8) (5) (5) (

(4) (4) (4) (4) 가

(extrusion) (orefin) (4) (4)

(4) (4) 2 (4)

(4) (4)

(4) , (4) , JSR
JALS - 428 Y ,

(pretilt angle) 0° 가 (4) 가
X (die)가 ,

2가 , 가
(salenium) 가 ,

(3) (3) , (4)
(3) (3) ,
(4) .

(4) 가 가 (3) ,

(3) (3) (3) (4) (5)
(3) (3) (4) 가 , (3) (4) (3) (4)

(3) (4) 50 200μm .

(3) (4) (11) 가
가 , 1 2 , 가 2
(3) (4) (2) 가
(3) (4) (5) 가 ,

(4) (5)가 (11) (3) (6) (3) (7)
(4) (5) (7) P (5)
(2) , P (8) (11) (3) (4)
(2) . P (8) (11) (11) (2)
(11) , S (9) (6) S (9) P
(6) S (9) (2)

(11) , (3) (4) (5)

(2)

7 2 , 1 (5) , 7
1

7 (15)
(13c) (14a), (13a), (14b), (13b), (14c),
(21b) (21a) (14a) (13a) ,
(13c) (14b) (13b) (21c) (14c)
(14a, 14b, 14c) , (13c)

(21a) , (20a)
(20b) (21b) ,
(10) (20c) (21c)
(21a, 21b, 21c) (20a, 20b, 20c) 1 (11)

S (15) (14a) (15) ,
(21a, 21b, 21c) , S 가 가 (15)가
, 1 , S 가 가 ,

(14a, 14b, 14c) 1 (4)
(14b 14c) 가 , (14b 14c)
, 1 (3) (4) (14b 14c) (13a 13b)

, , ,
, , ,
가 , , ,
가 , , ,

, , 가 , ,
, , , 가 , ,

(57)

1.

2.

1 ,
.

3.

1 2 ,
.

4.

;

-;

5.

4 ,

6.

4 5 ,

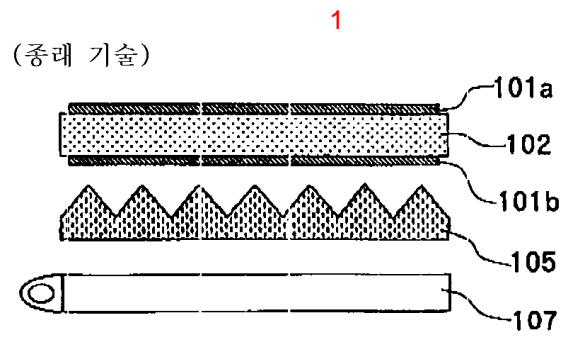

2

(종래 기술)

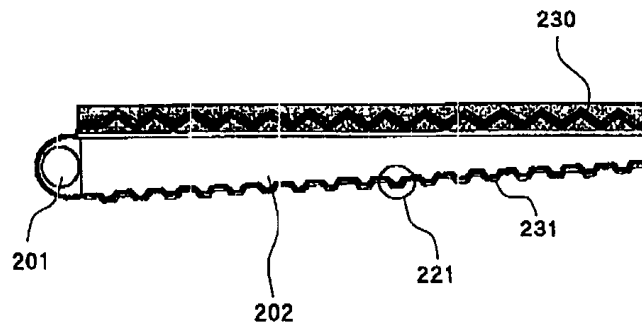

3

(종래 기술)

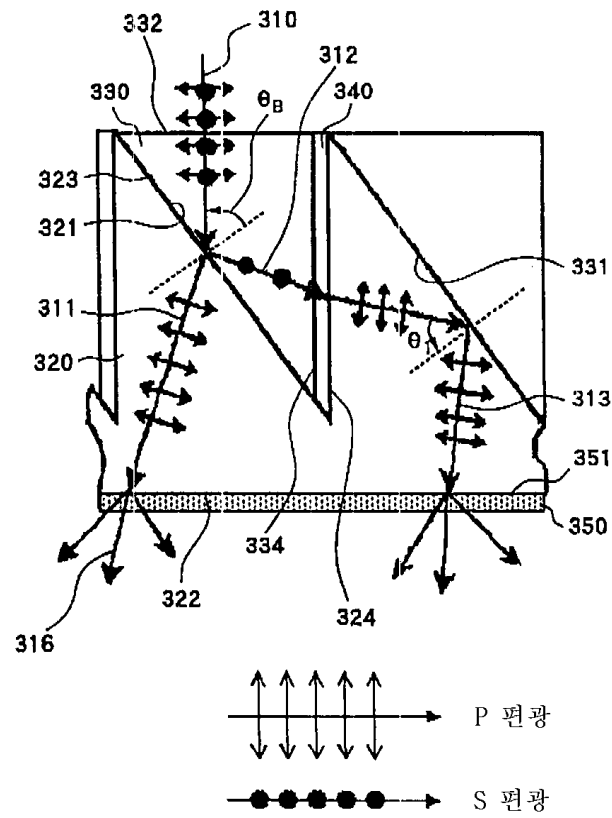

4

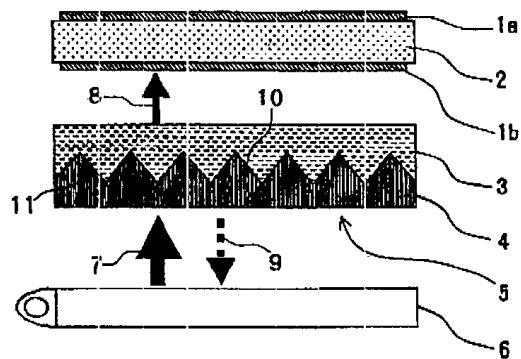

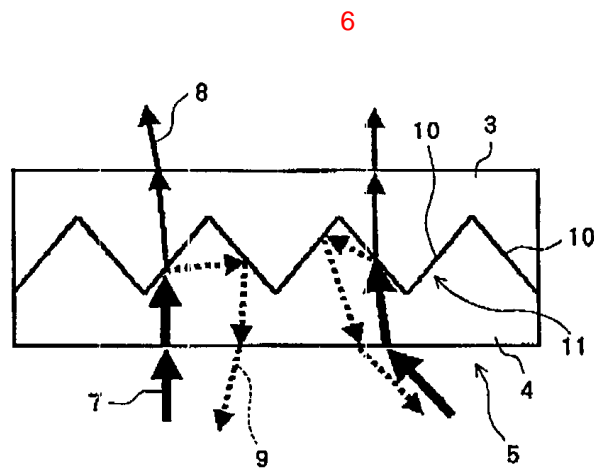
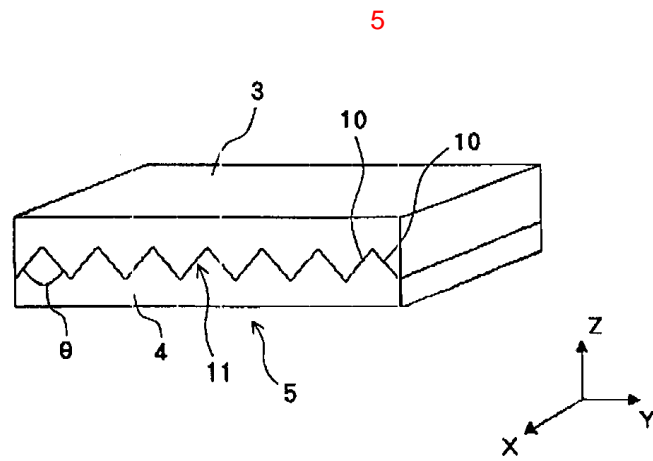

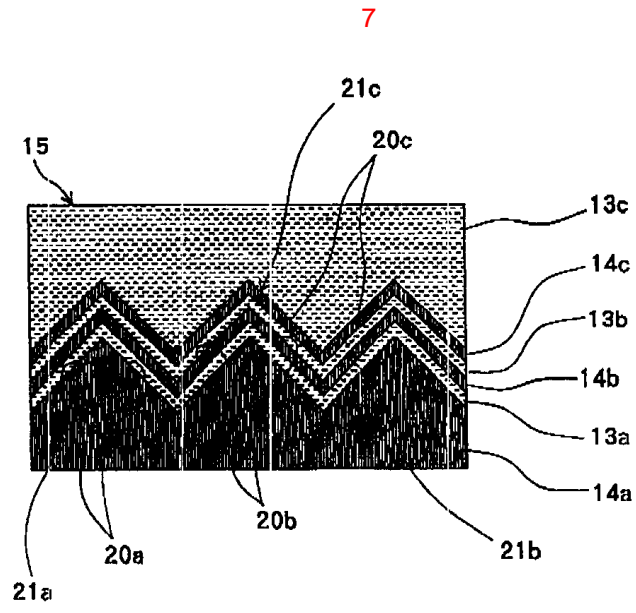

专利名称(译)	偏振元件和具有该偏振元件的液晶显示装置		
公开(公告)号	KR100350596B1	公开(公告)日	2002-08-28
申请号	KR1020000005026	申请日	2000-02-02
申请(专利权)人(译)	日本电气有限公司sikki		
当前申请(专利权)人(译)	日本电气有限公司sikki		
[标]发明人	MARUYAMA MUNEO 마루야마무넨오 FUJIMAKI ERIKO 후지마끼에리꼬		
发明人	마루야마무넨오 후지마끼에리꼬		
IPC分类号	G02F1/1335		
代理人(译)	CHANG, SOO KIL		
优先权	1999026570 1999-02-03 JP		
其他公开文献	KR1020000057869A		

摘要(译)

各向同性体和各向异性体被层叠，并且反射偏振元件被构造使得由多个棱镜表面构成的几何结构平面形成在各向同性体和各向异性体之间的界面上。当平面光中的P偏振光通过几何结构表面在液晶面板的垂直方向上会聚时，当来自背光的平面光进入各向异性层一侧的反射偏振元件的表面时到达液晶面板，亮度得到改善。S偏振光被背光侧的几何结构表面反射并重新使用。在反射偏振元件中，几乎不发生光学损耗，并且提高了光利用效率。 4 指数方面 反射偏振器，S偏振光，P偏振光，几何表面，主面，各向异性，各向同性，背光，偏振器，液晶面板 - 1 -

