

(19)  
(12)

(KR)  
(B1)

(51) 。 Int. Cl. 7  
G09G 3/36

(45)  
(11)  
(24)

2002 08 30  
10 - 0350726  
2002 08 17

(21) 10 - 2000 - 0053555  
(22) 2000 09 08

(65) 2002 - 0020418  
(43) 2002 03 15

(73) 14 - 1102

(72) 14 - 1102

(74)  
:

(54)

가 / , 2 /  
/ , 가 가  
/ 가 가

10

1	(TFT)	가	.
2			.
3			.
4	가		.
5	2		.
6	3		.
7	4		.
8	2	N N+1	.
9		TFT - LCD	.
10	2		.
**		**	
110:	120:		
130:	132: TFT		
134:	111:		
112:	113:		

(line time)

(Liquid Crystal Device: LCD)

(Thin Film Transistor:TFT) LCD / TFT

TFT가 / TFT (132)

(134), (130) TFT (source) (column) (gate) N x

(row) (D1~DN) (G1~GM) (110) (ROW)

M ( , SVGA 800x600, XGA 1024x768, UXGA 1600x1200)

(SCAN) (120)

1 (134) TFT(132) (drain) TFT 가 가

(120) 가 (134) 가 (ITO) 가

(Vcom) 가 (C<sub>STG</sub>) (storage on gate)

가 가 (inversion) 가

(TFT 가 ) (Vcom) (+)

(-)

2 (112), (113) (111) (110) (111)

(G1~GM) 30V (113)

, 가 3 (gate line; )

1 (line time:1H) 1 (gate line) 가

, LCD 가 (data line) 가 가

가 ( )

4 가 4

(interlace scanning) 2 (line time) 가

2 (gate line) 가 1/2

(line time)

2 / 가 /

5 2 ( )

5 , 2 (gate line) 가 가 (gate line) G1 G2  
 , 가 가 G1 G2 , (data line)  
 가 , 가 1 (G1)가 1 2  
 가 , 2 (G2)가 2

percentage ) , 2 30~70%  
 (gate line)

(line time) 17 μ sec 가 XGA(1024 × 768) 75Hz , 22~30 μ sec  
 (line time)

2 N , 6 3 , 5  
 7 4 (gate line)

(gate line) 가 가 (line time)  
 , 5, 6, 7  
 (gate line) 가  
 N- , 8 2- , (column)  
 , (row) 2- (N N- )

(gate) (line time)  
 (gate line) Vp 가  
 , Vp

TFT - LCD ,  $C_{LC}$  ,  $C_{STG}$  ,  $C_{GS1}$  ,  $C_{GS2}$  , G1 G2

g) , G1 ,  $(C_{LC})$  ,  $C_{GS1}$  (couplin  
 $V_p$  1

1

$$\Delta V_{P1} = \frac{C_{GS1}}{C_{LS} + C_{STG} + C_{GS1} + C_{GS2}} (-V_G)$$

LC 1 C , V  
 G

$V_p$  ,  $C_{GS2}$  (coupling) , G2 가 ,  
 $C_{GS2}$

, (gate line) 9  $C_{GS1}$  2 1  
 $V_{p1}$  , (gate line)  $C_{GS1}$  C  
 $V_{p2}$  가

2

$$\Delta V_{P2} = \frac{C_{GS1}}{C_{LS} + C_{STG} + C_{GS1} + C_{GS2}} (-V_G) + \frac{C_{GS2}}{C_{LS} + C_{STG} + C_{GS1} + C_{GS2}} V_G$$

$V_p$ 가 , 5 G1 가

10 (gate line)  $V_p$  가

, 10 2 G2, G4 (gate line) 가 , (gate line) 가, G1, G3  
 G1, G3 (gate line) 가 ,  
 (gate line) 2  $V_p$  가  
 가 (gate line)  $V_p$  가  
 가 가 ,

가 / 가

(57)

1.

( )

2

가

2.

( ) 1

N

, N

3.

( ) 2 가

가 가

가 가

가

4.

( ) 1 가

가 가

가 가

가

5.

( ) 1

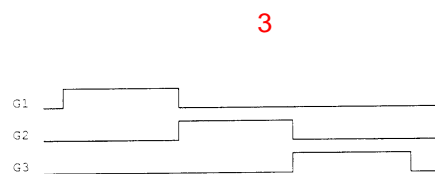
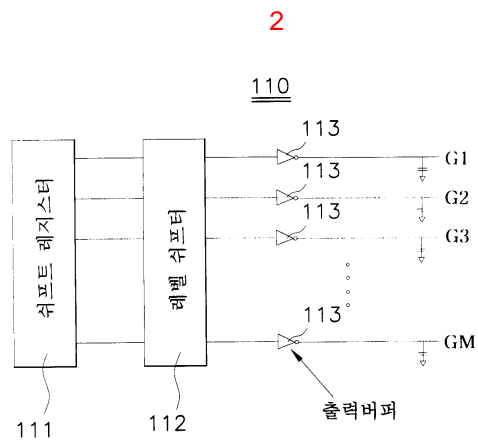
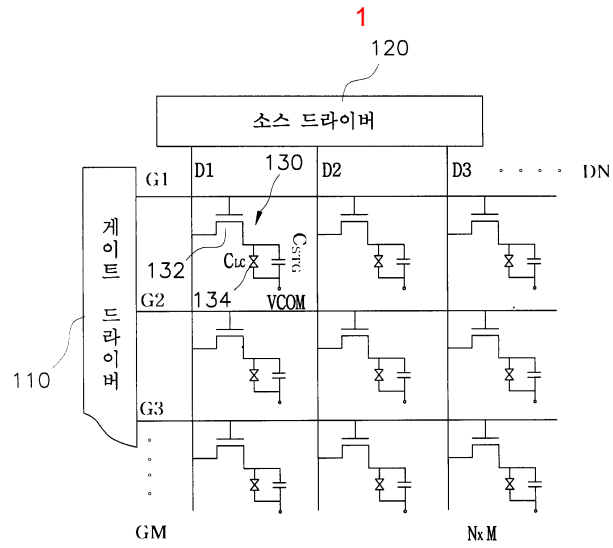

4

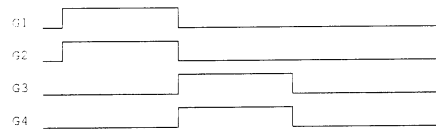

5

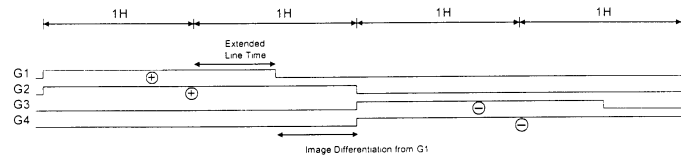

6

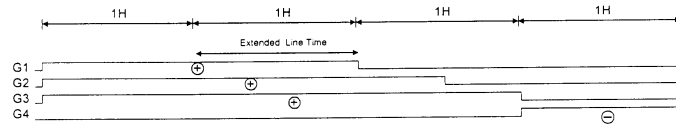

7

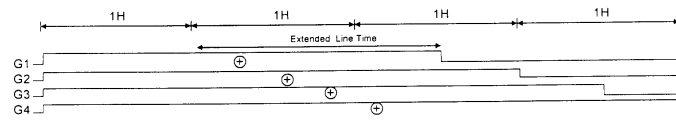

8

(N)th Frame						(N+1)th Frame					
-	+	-	+	-	+	+	-	+	-	+	-
-	+	-	+	-	+	+	-	+	-	+	-
+	-	+	-	+	-	-	+	-	+	-	+
+	-	+	-	+	-	-	+	-	+	-	+

9

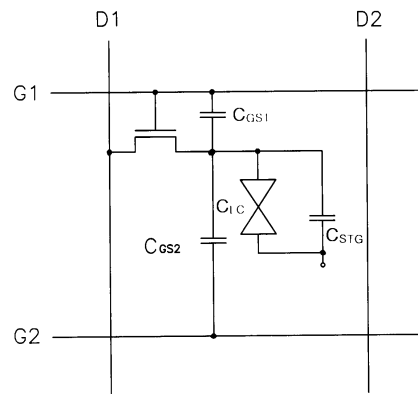

10

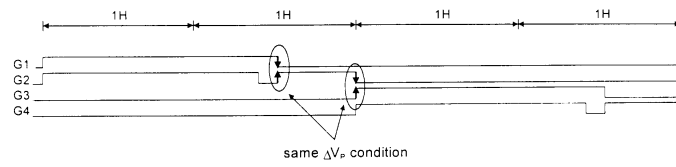

专利名称(译)	液晶显示装置的栅极驱动方法		
公开(公告)号	<a href="#">KR100350726B1</a>	公开(公告)日	2002-08-30
申请号	KR1020000053555	申请日	2000-09-08
[标]申请(专利权)人(译)	KWON OH KYOUNG 权, 呵呵 - 灵		
申请(专利权)人(译)	权, 呵呵 - 灵		
当前申请(专利权)人(译)	权, 呵呵 - 灵		
[标]发明人	KWON OH KYOUNG		
发明人	KWON, OH KYOUNG		
IPC分类号	G09G3/36		
其他公开文献	KR1020020020418A		

摘要(译)

本发明驱动多条栅极线，但在同一时间上的大尺寸的高清晰度的液晶显示器可以在时间线延伸到在液晶显示装置中的扫描信号的不同下降时间装置的栅极驱动方法。根据本发明的驱动液晶显示器的栅极线的方法是通过将扫描信号同时上升/下降到至少两条栅极线来驱动液晶显示装置的栅极线的方法，同时驱动栅极线，在不同的下降/上升时间将图像信号传输到数据线，从而延长线时间而不降低分辨率。因此，根据本发明，扫描信号同时施加到多条栅极线，但是下降时间不同，从而增加了线时间而不降低分辨率，从而充分地像素电极充电/放电。此外，通过使奇数行和偶数行的下降条件相同，可以防止由寄生电容引起的图像质量的劣化。 10 指数方面 液晶显示，栅极驱动，线时延长

