

(19)
(12)

(KR)
(A)

(51) 。 Int. Cl. ⁷
G02F 1/1333

(11)
(43)

2003 - 0031401
2003 04 21

(21) 10 - 2002 - 0027417
(22) 2002 05 17

(30) JP - P - 2001 - 00317500 2001 10 15 (JP)

(71) 가 가 가 가 4 1 - 1

(72) 가 가 가 가 가 4 - 1 - 1 가 가
가 가 가 가 가 4 - 1 - 1 가 가
가 가 가 가 가 4 - 1 - 1 가 가

(74)
:

(54)

가 (2) (26) (ln) n n+1 ° (2)
가 0.1

1	1						
2	1		1 - 1				
3	1		1 - 1				
4 (L11)	Si	o (2)	(L10) (L11)	(6) ()	,	(6)	(4)
5	(2)		(球形)				
6	2 μ m	()					
7	2.5 μ m	()					
8	3.5 μ m	()					
9	4 μ m	()					
10	2 4 μ m	()	가 90°	25°			
11 (2)	1		1 - 1				
12	(2)	(ln)	(26) n	가	,	(26)	(ln)
13	(ln)		(ln)				
14	(2)	(deg.)		(%),		(%)	
15	(ln)		(ln)				
16	15			1	3		
17							
18							
19						(20)	
20							
21	1						

22	1	(100)	가	.
23	1			,
24		(2)		.
25	TN			.
26	2	VA		.
27	2			.
28	2			.
29	2			.
30	2			.
31	2			.
32	2			.
33	2			.
34	2			.
35	2			.
36	2			.
37	2			.
38	2			.
39	2			.
40	2			.
41	2			.
42	2			.
43	2			.
44	2			.
45	2			.
46	2			.

47	2			.
48	2			.
49	2			.
50	2			.
51	2			.
52	2			(2)
	.			
53		.		
54	3	1		.
55	3	3 - 1		
56	3	4		.
57	3	8		.
58	3	3 - 1		.
59	3	3 - 3		.

*

1, 100, 101 :

2, 102 :

4, 104, 105 :

4a, 104a, 105a :

6, 106 :

8, 108 :

10 :

12 : 1

14 : 2

16 : 3

18 : TAC

20 :

22 :

24 :

26 :

30 :

32, 34 :

36, 38 :

39 : 2

40 :

110 : (前方)

112, 114 :

116, 118 :

In :

L1, L2, L3, L4, L5, L6, L7 :

:

:

:

VA

가

5 - 232465

가

8 - 338993

1

. 1 , 1

21 1 (100)

() (102) (102) (/4)

(106) (106) (108) (104)

(104) 2 가 ()

가

(104) 가

가 () 1

(100) , 가 (,)

22 1 (100) (104) (104a)

22a 가 (104a) , 22b 가

(104a) , 22 가

(104a) (anchoring)() 가

(retardation)() 가 가

가 , 가

(Y.Itoh, N.Kimura, S.Mizushima, Y.Ishii and M.Hijikigawa, AM - LCD2000 digest, p.243(2000)).

23 21 1 (101)

(105) () , 21 (105)

가 VA(Vertically Aligned) 가 1

(101) , 가 (,)

(101)

(102) , (102) 가

가

1° 가 , n n+

가 0.1

[1]

1 1

20 , 1a () , 1b () (1)

(2) (2) (8)

(/4)(6) (6) (4) ()

(4) ()

(4) , VA , .1 가 (1) , 가

, 1a , (8) () (10) () (10) (L2)

(8)) , (L1) /4 (6) (L2) (8) , (L1)

(4a)) (L3) (4) (4) 가

(L4) , (L3) (4a)

(4) (L4) (2) (4) (L4)

(L5) , (L5) /4 (6)

(L6) /4 (6) (L6) (8)

(8) 가 .

, 1b , (8) , (L2) (8) , (L1)

(8) (4) , (L1) /4 (6) (L3)

(4) (4) 가 (4a) (2) (L3)

(L3) 180° , (4) (4)

(L7) (4) /4 (6) , (L8)

(L7) /4 (6) (L8) (8) (8)

(8) 가 , (2)

가 .

, /4 (6) (4)
(2) 가 .

, 1 (2) 가 ,
n n+1° 0.1
가 .

[1 - 1]

2 2a 2b (optic axis) 2a 2b
(6) /4 (12) 2 (/4)(14) 1
(6) /4 (4) 3 (가
VAC75)(16)
(4) , 가 n=0.1 (Merck Japan Ltd.)

e) (8) , (TAC (18) G1220DU)(20) TAC(Triacetyl Cellulos 가 .

3 1 2 VA (1) (L10)
(2) (L11) ()
o , o x ()
) , x y ()
z ()
3 Si , o Si x - y (射影)
x i(x (正側)) z
i(z (負側))

Si o (L10)(=550nm) (8) (6) (4)
(L11) (2) (L11) () 4 . 4
(L10) i(deg.) , (L11) ((deg.;))
i 0=0° 17=170° 10° 18
0 17 . (4) (z ;) 3μm .

4 , i=0° i ()가 90° ,
i () 90° , , 11=110°
° 15=150° ()가 90° .

(2) (1) 5 G1 G2
 (2) 1μm (2) 5 24
 (22)가 5 24
 3μm, 3.5μm 4μm 2 3μm, 2.5 3.5μm 3 4
 μm 6 9 2 4μm ()
 6 9 (L10) i(deg.) (L11) ((deg.))
 0 17 i 0=0° 17=170° 10° 18
 (4)
 10 6 9 () ()
)가 90° 25° 10
 2 4μm ()가 90° 25° i 10
 μm 2μm =10 50° ()가 90° 25° 2.5
 =50 180° =30° 3.5μm =100 160° 4μm =0 10°
 ()가 90° 25°
 3μm 10 2 3μm ()가 90° 25°
 =10 50° =120 140° (L10) (L1
 1) (2) ()가 90° 가
 3.5μm , 2.5 3.5μm , 10
 =30° =100 160° (L10) (L11) (2)
 ()가 90° 4μm , 3 4μm
 0) (L11) (2) =0 10° =50 180° (L1
 ()가 90°
 () ()
 (2) i
 가 ((i+90°))
 3μm =10 50° =120 140°
 11
 (2) TFT(;Thin Film Transistor)
 , TFT()
 (2)
 (2)
 (1) , TFT AFP750(Clariant Japan) 3μm

- (2) TFT , 110 2 .
- (3) TFT , 135 80 .
- (4) TFT , UV() 2600mJ/cm² .
- (5) TFT , 215 60 .

(6) Al() 200nm . , Al () () .

11 , TFT (2)
 =0° =90° AFM() , 12 (2)
 (In) (26) 가 , (26) (In) 3 .

13 (In) n , (In) n=0° (In) n=90° 가
 . 13 , (In) 가 (2) VA
 가 , 3μm
 () 2a (8) (6)
 2b 3 x - y - z x - y - z
 2b (8) (20) () TAC (1
 8) =15° , nx ny 가 n
 x ny, nz , nx ny 가 .

2b (6) 1 (12) =25° , 2
 3 (16) =80° 2b ,
 2a (2) 11 .
 (2) , 가 (2) (4) 5V
 , 가 (4) 가 .

14 . 14 (2) (deg.) , 14 ,
 (%) =0° (=180°), =90° (%) 가 ,
 . 11 (2) , =0° =90° 가 ,
 =45° =135° 가 =0° =90° ,
 , =45° =135° , =0° =90°

0° , (8) =120 (6) 140° (4) , 10 =10 5
 , 가

[1 -2]

n (2) (26) (In) 15 . 15 (2) (In) 1 1 - 1
 (2) , 3 (2) . 2

2 (2)
 (1) , TFT AFP750 3μm
 (2) TFT
 (3) TFT , 110 2
 (4) TFT , 135 80
 (5) TFT , UV 2600mJ/cm²
 (6) TFT , 215 60
 (7) , Al 200nm , Al ()
 , 3

(1) , TFT AFP750 3μm
 (2) TFT , 90 20
 (3) 10μm
 (4) TFT , MF319(Shibley) 1
 (5) TFT , 125 40
 (6) TFT , UV 1300mJ/cm²
 (7) TFT , 215 60
 (8) Al 200nm

15
 , 16 () (=0.10)
 , 1 1-1
 1 3 , 가
 3 , 2 (=0.32)
 (=0.56)가

VA
 , 2 (8) (6)
 17 , 3()
 2 1 , 16 가
 (=0.32 0.56; 0.5)가
 (=0.10)

[1-3]

10 , 3.5μm 4μm (2)
 =30° =100 160° (=50 190° (=120°)
 0° =130° =120° =30° =3
 =145° , =120° =130°

[1-4]

(2) , 18 (2) 가
 가 (8) , (2) 18 ,
 60° 7°, 10° 13° , 30°, 45°
 (1) (2)
 7 15°

, (2) VA ()
 n=0.1 , 3μm) (2)
 (1) , 0.7mm AFP750
 (2) , 90 20
 (3) , UV 2600mJ/cm²
 (4) , 215 60

1.4 μm AI 200nm
 1 μm 1.1 μm , k=11 $^\circ$ 24c
 AI 200nm
 0.5 μm , k=8 $^\circ$.

24 (2) , (2) 가
 TN

TN VA 25 26
 25 26 가 21 22 1 (112, 114)
 (110) 가 (104a) 25 TN , 25a
 가 (104) (2)
 /4

25b 가 (104a) 가 0
 가 4 5V 가 가 15

26 VA 26a 가
 (105a)가 (105) /4 26b (105)
 가 (= n · d; n , d) (2)
 , VA () 4V

27 51
 n A(n=0.1, = -7)
 1=450nm, 2=550nm, 3=650nm 3가

27 31 , 1.5 μm n · d=150nm , p p= (;
 가), p=d() × 5=7.5 μm , p=d × 4=6 μm , p=d × 3=4.5 μm , p=d × 2=3 μm 가

32 36 , 2 μm n · d=200nm , p p= , p=d × 5=10 μm , p=d ×
 4=8 μm , p=d × 3=6 μm , p=d × 2=4 μm 가

37 41 , 3 μm n · d=300nm , p p= , p=d × 5=15 μm , p=d ×
 4=12 μm , p=d × 3=9 μm , p=d × 2=6 μm 가

42 46 , 4 μm n · d=400nm , p p= , p=d × 5=20 μm , p=d ×
 4=16 μm , p=d × 3=12 μm , p=d × 2=8 μm 가

47 51 , 5μm n · d=500nm , p p= , p=d × 5=25μm, p=d × 4=20μm, p=d × 3=15μm, p=d × 2=10μm 가 .

27, 32, 37, 42 47 , 가 p= , (105) n
 · d n · d 가 , (105) n
 · d=500nm 가 () , 47 n
 50nm , , 가 2V , , 27 n · d=1
 , 4V 가 (trade - off)

가
 , 27 51 , d 3 4 가 p
 , 가

, n 0.05 , - 3.8 , n
 A , (2) 가 가 ,
 UV ,

, TN VA(Vertical Alignment)
 ,
 , 가 가 ,
 가 가 , 가 ,

(1,462,978 9 - 266889) ,
 df · {(nx+ny)/2 - nz} dlc · n ,
 , 가 .

52 (2) . (2)
 1

()¹ 가 (2)

52 , N=1.0, (TAC) N 1.5, N 1.5 , TAC ,
 TAC dv () 1 2 , TAC
 dv/cos² dv/cos³ 3 . TAC

(2) , TAC dv/cos² dv/cos² ,
 dlc/cos³ dlc/cos² , dlc , TAC
 dv .

(2) 가 1 .

53a , TAC 가 53b , Z

53a 53b , X - Y (常光) No' , Ne'
 X X - Y () , 53c 53d ,

(Z) , Ny' , Nz' Y - Z 53c 53d
 , Y - Z Y - Z Ny'

[1]

[1]

$$\frac{Y^2}{Ny^2} + \frac{Z^2}{Nz^2} = 1$$

$$\frac{Ny'^2 \cos^2 \theta}{Ny^2} + \frac{Ny'^2 \sin^2 \theta}{Nz^2} = 1$$

$$Ny'^2 = \frac{1}{\frac{\cos^2 \theta}{Ny^2} + \frac{\sin^2 \theta}{Nz^2}}$$

$$Ny' = \frac{Ny Nz}{\sqrt{Nz^2 \cos^2 \theta + Ny^2 \sin^2 \theta}} = \frac{Nz}{\sqrt{\frac{Nz^2}{Ny^2} \cos^2 \theta + (1 - \cos^2 \theta)}} = \frac{Nz}{\sqrt{1 - \nu \cos^2 \theta}}$$

단, $\nu = \frac{Ny^2 - Nz^2}{Ny^2}$

Nz' [2]

[2]

$$\frac{Y^2}{Ny^2} + \frac{Z^2}{Nz^2} = 1$$

$$\frac{Nz'^2 \sin^2 \theta}{Ny^2} + \frac{Nz'^2 \cos^2 \theta}{Nz^2} = 1$$

$$Nz'^2 = \frac{1}{\frac{\sin^2 \theta}{Ny^2} + \frac{\cos^2 \theta}{Nz^2}}$$

$$Nz' = \frac{NyNz}{\sqrt{Nz^2 \sin^2 \theta + Ny^2 \cos^2 \theta}} = \frac{Nz}{\sqrt{\frac{Nz^2}{Ny^2} (1 - \cos^2 \theta) + \cos^2 \theta}} = \frac{Nz}{\sqrt{\frac{Nz^2}{Ny^2} + \nu \cos^2 \theta}}$$

Nx', Ny', Nz'

dlc 3μm,

n 0.1 ,

3

[1]

[1]

			(1)		(2)		(3)	
A	13.06	46.77	15.26	32.6%	29.65	63.4%	36.32	77.7%
B	8.98	23.14	9.05	39.1%	16.15	69.8%	19.04	82.3%
C	7.67	17.09	7.53	44.1%	12.85	75.2%	14.82	86.7%
D	7.48	13.63	6.64	48.7%	10.92	80.1%	12.35	90.6%

[2]

			(4)		(5)		(3)	
A	13.06	46.77	41.81	89.4%	47.12	100.7%	51.34	109.8%
B	8.98	23.14	21.73	93.9%	24.34	105.2%	25.96	112.2%
C	7.67	17.09	16.83	98.5%	18.77	109.8%	19.76	115.6%
D	7.48	13.63	13.96	102.4%	15.52	113.9%	16.15	118.5%

7nm ,

()

가

1

가

Z

df (1) 79μm, (2) 83μm, (3)

87μm, (4) 84μm, (5) 88μm, (6) 89μm,

{(nx+ny)/2 - nz} (1) 0.

0006, (2) 0.0013, (3) 0.0015, (4) 0.0018, (5) 0.0020, (6) 0.0022 ,
 (nx=ny).

1 (1) (6) (4)가
 가 , .

가 dlc n ,
 dlc · n ,

0.5 $[df \cdot \{(nx+ny)/2 - nz\}] / (dlc \cdot n) \quad 0.7$

10% , .

가 1 (試作) ,
 가 가 14 47nm , 7 13° (4) (6)
 가 ,

0.4 $[df \cdot \{(nx+ny)/2 - nz\}] / (dlc \cdot n) \quad 0.7$

VA ,

0.4 $[df \cdot \{(nx+ny)/2 - nz\}] / (dlc \cdot n) \quad 0.7$

90° 2 , 1 (가 ,
) 2 1 ,
 1
 , 1 2 2 1
) (, 2
 1 , 1 , 2
 2 , 2 1

(Shibley) , 200 60
 135 40 ,
 7.7 ° ,
 AI 200nm

, TFT CF (JSR) , 3μm (= -7.0)
) n 0.1 (Merck Japan Ltd.) VA

CF

- (1) : 15 ° (가).
- (2) /2 : 275nm 1 (JSR). 25 ° .
- (3) /4 : 135nm 1 (JSR). 80 ° .
- (4) VAC70 : 2nm, 154nm 2 (가).
 80 ° .
- (5) : VA

(2) (3) /4 , /4
 . (2) (4) 가
 (540nm) 1/2 (2) (4) . (4) 가
 , (1) df · {(nx+ny)/2 - nz} [df ·
 {(nx+ny)/2 - nz}] / (dlc · n) = 0.51 .

VAC70

CF

- (1) : 2 - 4 .
- (2) VAC70 : 2 - 4 .
- (3) /2 : 2 - 4 .
- (4) /4 : 2 - 4 .
- (5) : 2 - 4 .

1

CF

- (1) : .
- (2) /2 : 2 - 4 .

(3) /4 : 2-4 .

(4) : 2-4 .

2 TN , CF

(1) : 2-4 .

(2) /2 : 260nm 1 (JSR). 25° .

(3) /4 : 115nm 1 (JSR). 80° .

(4) : TN

(2) /4 가 , /4 23nm () ,

가 가

(4) (JSR) , 3μm (=6.0) , (n 0.067 (가 가))

2-4, 1 2 가 ,

가 , 가 () .

2 55%) , 37(116% 가) 0.29(2 /4 2) , /4 VA 1(가 가) , VAC70 ,

[2]

[3]

			CR
		0.29 10.82	37.3
		0.45 10.63	23.6
1		0.60 11.05	18.4
2		0.64 11.02	17.2

(가)

0V, 4V

2.5V, 0V

3
) 30° , , 45(92% 가) . 0.56(2 48%

[3]

[4]

			CR
		0.56 25.27	45.1
		0.70 25.14	35.9
1		0.90 25.45	28.3
2		1.08 25.36	23.5

(가)

TFT , , , CF

[3]

3 54 59

가

Taylor: J. Appl. Phys. 45 4718 1974)가 (GH) (D. L. White and G. N. GH 5 6 .

711)가 1 (TN) (1 - 319261 06 - 011 () ,가 1/4 90° GH 40% 12 14 .

, TN 11 - 311784) (16 18 .

가 (Vol.50, No.8, pp1091 1095, 1996). GH 40% 1 12 TN 16 18 , GH TN 가

1 TN 11 - 311784

1 VA 가 (1 - 319261). VA ,가 ()가 TN 1/4 90° , 90° , 가 , TN , VA () 가 .

2000 - 29030 가

1 - 319261

가 ,
 가 , VA 1
 1 , 2
 (1)
 1 , 1 2 , 1 2
 , 2 ()
) 1 ()
) , .

54 1 54
 (112) (112) (114) (μm) ,
 (a.u.) , 가 (4a) (112) ,
 (30) , 54 S2, S3, S4 가 (114)
 S3 , 가 (32, 34) () (36)
 , 가 (4a)가 .

54 (36) , (30) , , (30)
 (36) (30) 가 (30)
 , (30) (4a)
 2 .

(2)

1 , 2 1 1 ,
 , 2 1
 55 55 (36) 1
 55 (4) 가 (30) (30)
 (36) (32, 34) (30) (4a, 4b)가
 55 (30) W2 , (30)
 (36) W1 .

2 (30) , 가 (30) 90° (36) , (30) . (30) , (逆) 가 . 가 1/4 (roughness) , (36) (30) , (36) 가 가 가 , 가 가 R(), G(), B() 3 1 () 가 3:1 (30) , (30) 1/3 . (30) , 1 (36) 2 (30) , (30) (36) 1 (30) , (30) 180° (30) 1 (36) 2 (30) (30) , (30) (30) (30) (30) 180° , 2 (30) 2 . (3) 2 W1 1 (W1/W2) 3 (30) (36) W1 (30) W2 , (36) (30) , 가 . 55 W1 (30) (36) (30) W2 6μm , 가 (36) 2 가 5% (30) 2μm 2%, 4μm 3%, 6μm 4% , (36) 2 (30) W1

가 W1 W2 , (30) W1 W2 가
(36)

(4)

1 1
, 2 ,
56 56 (36)
56 (4) 가 (30)
(36) (34) (30) (4b)가
56 W1 (30) W2 (30)
(36)

(36) (30) , ,
(30) 가 가 (30) 가
90
° () 가 ()
, 가 가

(5)

4 W1 $\frac{1}{2}$ (W1/W2) $\frac{3}{2}$ 2
, , (36) (30)
, W1 2

(6)

1 , 1
(30) 가 , 55 56 , (30)
(38) 가 (36) W1 ,
(30) (30) 가
가

(7)

1 , 가 , 1 2 . 56
 (40) .
 (36, 38) , 가 , (36, 38)
 (30) 가 , (4) , (3)
 6, 38) , (4)
 (8)

1 , 1 2
 4 μ m 2
 .
 (30) , (30)
 57 가 , 가
 , 1 2 (30) 2 (30)
 4 μ m (36) , (39) (30) (30)
 (36) , (30) (30)
 (36) , 4 μ m W1 , 2
 , 2 (39) , 2 (39)
 (39) (30) (36)
 (30) (39) (30) (36)
 (30)

, 2 (39) 가 , 2 (39)
 (4a, 4b)가 ,
 , 2 (39)
 , 90° (4a, 4b)가 (36, 39)
 (36, 39) , 4 μ m

(9)
 1 , 4 μ m 2
 (,) .
 8 2 (39) (30)
 . , (30) ,
 , 2

가 , 가 . ,

(10)

8 9 , 2 ()

2 ,

, 가 . , ,

, 2 , 2

(11)

1 , 가

, , 가 .

, , 가 가 , 가 , 가

, 가 .

(12)

1 , 2 ,

, 2 , ,

. 1 , , 2 가

, 1 , 2

, 1 1 . 2

(13)

1 (改質) 1
 가 . , .
 , , .
 , 1 CF , .

(14)

1 2 , .
 , . VA
 가 ,
 가 .

((zero)) , , .

90° ,
 , 90° ,
 , 가
 (,) .

1 , 가 , 가 ,

[3-1]

(Shibley) 3μm , TFT
 , 135 40 , 200 90 30
 , Al , AI
 ()

90 30 3μm
 , 2
 1

55 (30) 55 (4) 가
 (30) (36) (32, 34)
 (30) (30) (4a, 4b)가 ()
 W2 (30) 6μm , 55 (30)
 (36) W1 6 18μm (30) (36) 0 6μm
 (36)
 가 (36) 가 (36)

, , , 130 2 , 220 60
 ()

, TFT (JSR) T
 FT 3μm ()
 d.) (= -7.0) () n 0.1 (Merck Japan Lt

/4 150nm , 가 1
 4 58

58 , (a) (b) $w1/w2=1.0$
 1A , (c) (d) $w1/w2=1.7$ 1B , (e) (f) $w1/w2=2.3$ 1C
 , (a), (c) (e) , (b), (d) (f)

W1 W2 (1A), 가 가
 (1B 1D). , 가

가

45°

가

x,

가

가

가

x,

가

가

가

, $W1/W2 = 3$

W1 1 $W1/W2 = 3$

가

[4]

[5]

	W1/W2			CR			
1A	1.0	11.3%	0.25%	45.2	x		
1B	1.7	11.1%	0.25%	44.4			
1C	2.3	11.0%	0.27%	40.7			
1D	3.0	10.9%	0.30%	36.3			
	-	11.0%	0.35%	31.4			

[3-2]

3-1

TFT

1.5 μ m

(3B; 59 (a)).

3-1 , CR
 3-2 6 , 59 2
 3A(59 (a)) 가 2

[6]

[7]

	W1/W2			CR			
3A	1.7	10.5%	0.25%	42.0			27ms
3B	1.7	10.8%	0.25%	43.2			45ms
	-	11.0%	0.35%	31.4			25ms

[3-4]

3-1 TFT 2
 90 30 3μm
 2 1
 , 130
 2 , 220 60 ,
 , TFT 1.5μm
 90 30 4μm
 2
 W2 6μm, W1 10μm ,
 2μm , 130 2
 , 2 AI , 2

3-1 7 (7 4) 3-3 (AI)
 가 ,

3A
 () . 2
 2

[7]

[8]

	W1/W2			CR			
4	1.7	8.0%	0.25%	32.0			27ms
	-	11.0%	0.35%	31.4			25ms

[3-5]

3-1 TFT
 , TFT
 (Merck Japan Ltd.) 0.3wt% 3-1
 , DC 10V 가
 10% 3-1
 8

B 0.3V ,
 () ,
 가 , 가
 , 2.3V 0.3V

[8]

[9]

	W1/W2			CR			
1B	1.7	11.1%	0.25%	44.4	1.60		43ms
5	1.7	11.1%	0.36%	30.8	1.30		25ms
	-	11.0%	0.35%	31.4	1.10		25ms

[3-6]

3-1 TFT , TFT 4
 5° 2000mJ/cm² ,
 3-1 , 3-5
 9

3-6(9 6)

가

[9]

[10]

			CR					
6	11.0%	0.25%	44.0	1.20			25ms	
	11.0%	0.35%	31.4	1.10			25ms	

[3-7]

1.5 μ m, TFT, 90, 30, 135, 40, 200, 60, TFT, Cs, 가, 가, (), Al, TFT, 45°, 2000mJ/cm², 3-1, 10, CR, 30°, 3-7(10, 7, CR, CR, 90°

[10]

[11]

	/ /CR	/ /CR	/ /CR	/ /CR
7	22.0/0.37/59.5	23.0/0.38/60.5	12.0/0.70/17.1	12.0/0.18/66.7
	17.0/0.28/60.7	17.3/0.29/59.7	16.9/1.00/16.9	17.1/0.25/68.4

, 1

가 ,

1

(1)

가

가 0.1

, n

n+1°

(2)

1

, 0.5

(3)

1 2

, 가

(4)

1 3

, 가

(5)

1

, 1 4

(6)

5

(7)

6

2

(8)

$n \cdot d$ ($n \cdot d$)가 150nm , 500nm , ()

(9)

$\{ (nx+ny)/2 - nz \}$ 가 0.4 [$df \cdot \{ (nx+ny)/2 - nz \} / (dlc \cdot n)$] 0.7 1 , $df \cdot$

(10)

9 , 1 2

(11)

8 10 ,

(12)

8 11 , 2
가

(13)

8 12 , 2
/4 ,

(14)

8 13 ,

3

(15)

1 , 1 , 2 2 , 1
2 1 , 2 ,

(16)

15 , 1 , 2 ,
1 ,

(17)

16 , W1 ,
W2 , 1 (W1/W2) 3

(18)

15 , 1 , 2 ,

(19)

18 , W1 ,
W2 , 1/2 (W1/W2) 3/2

(20)

15 , 1 ,

(21)

15 , 1 2 , 가

(22)

15 , 1 2 ,
4 μ m 2

(23)

15 , ,
4 μ m 2

(24)

15 , 가

(25)

1, 1, 2, 1
 2, 1, 2
 2, 1, 2

(26)

25, .

(27)

1, 1, 2, 1, 가, 2, 1
 2, , 가, 2, 1
 , .

(28)

15 27, .

(57)

1.

n, n+1°, 가, 가 0.1

2.

1, 0.5, .

3.

1, ,

1 2

4.

1 2 ,
 1 2 n · d()가 150nm 500nm ,
 1 , d 2 (가)

5.

3 4 ,

$$\frac{df \cdot \{(nx+ny)/2 - nz\}}{0.4 [df \cdot \{(nx+ny)/2 - nz\}]} / (dlc \cdot n) \cdot 0.7$$
 , dlc (, n df 1 , nx, ny, nz 1 xyz (異常光) ne (常光) no) .

6.

5 ,
 1 2 .

7.

1 ,
 1 , 2 ,
 1 2 ,
 2 1 ,

8.

7 ,
 1 , 2 , 1 ,

9.

8 ,

W1 ,

W2 ,

1 (W1/W2) 3

10.

7 ,

1 ,

2 ,

11.

3 10 ,

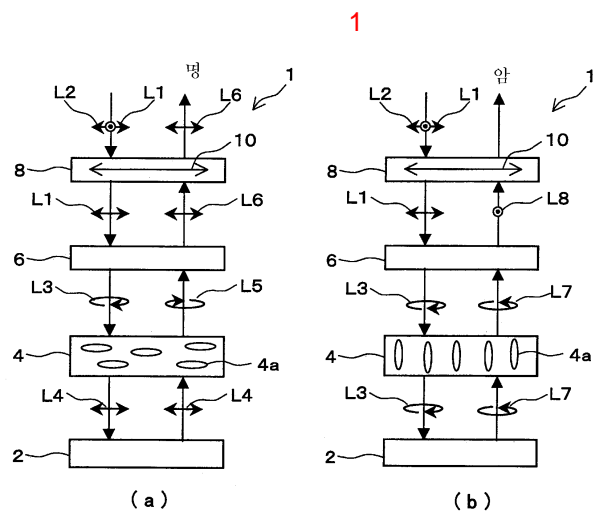

2

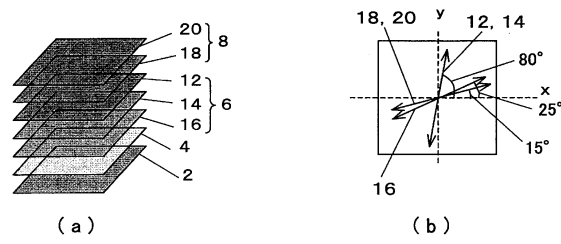

3

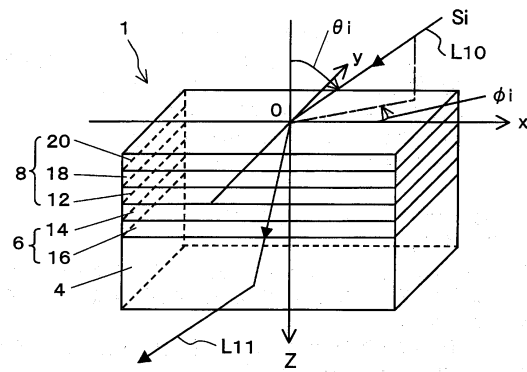

4

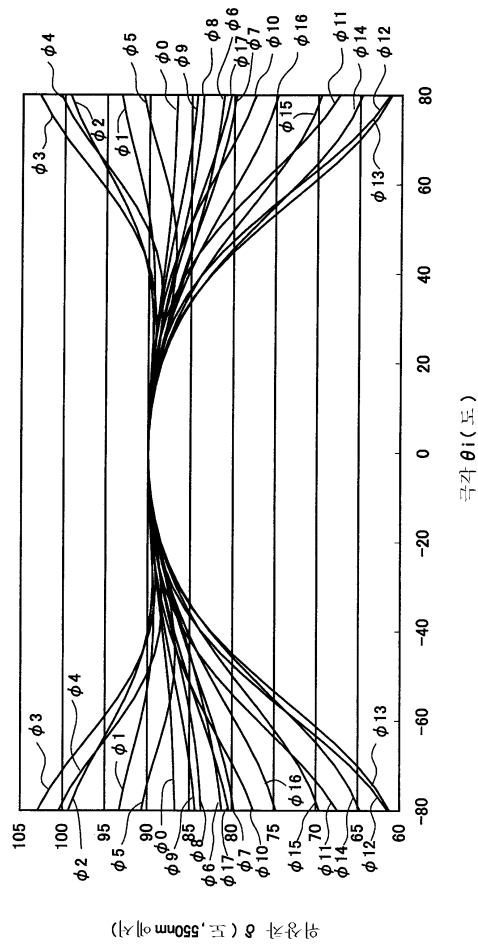

5

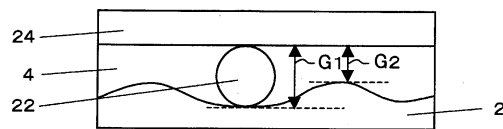

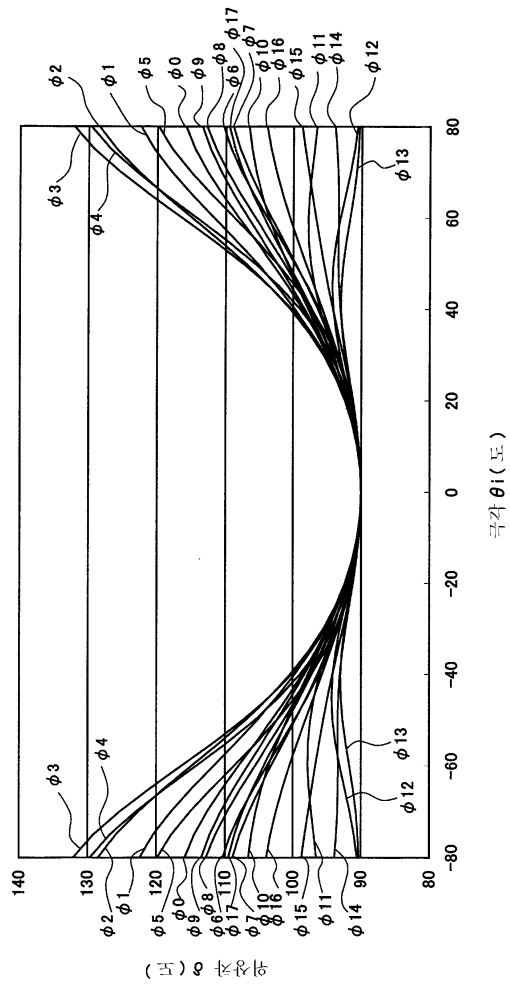

(五) 各曲线

7

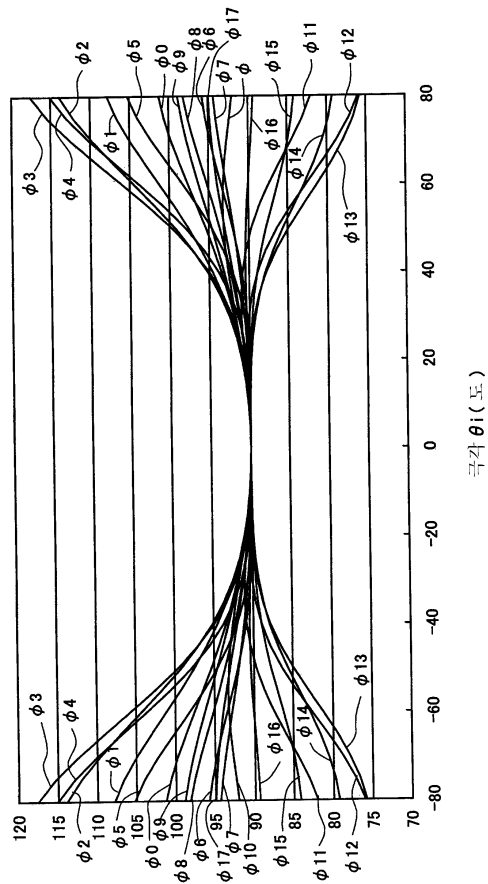

(五) 各曲线

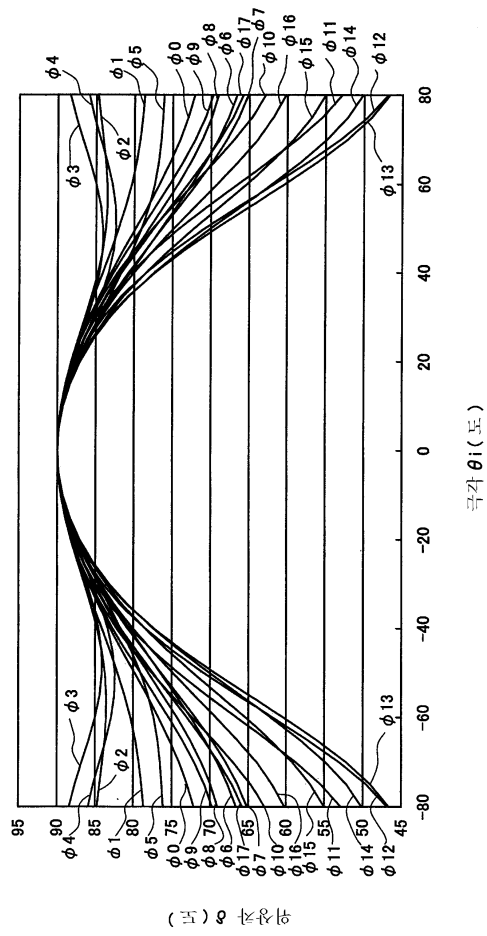

9

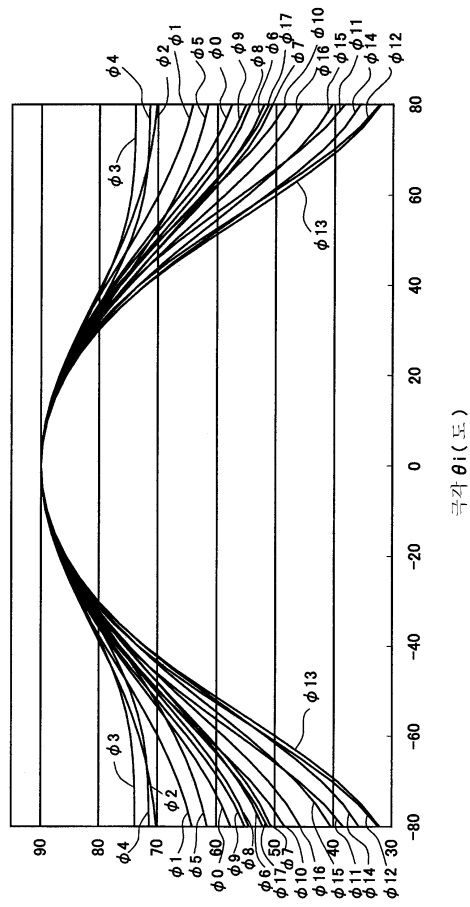

(五) ϕ 各層長

10

셀 겹	δ 가 90° 이하 25° 이상 어긋난 방위각 조건
2um	$10 \sim 50^\circ$
2.5um	30°
3um	$120 \sim 140^\circ$
3.5um	$100 \sim 160^\circ$
4um	$0 \sim 10^\circ, 50 \sim 180^\circ$

11

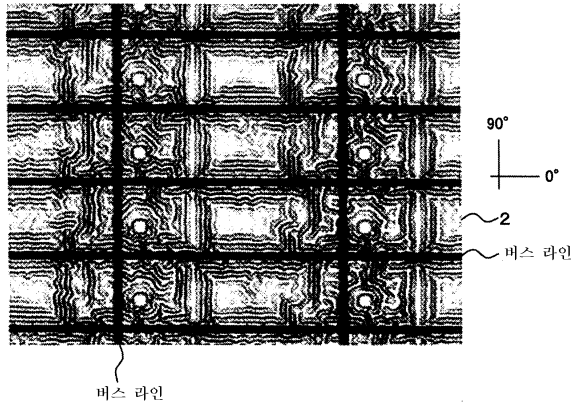

12

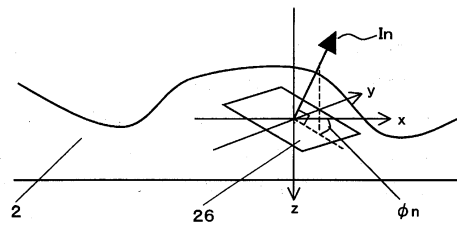

13

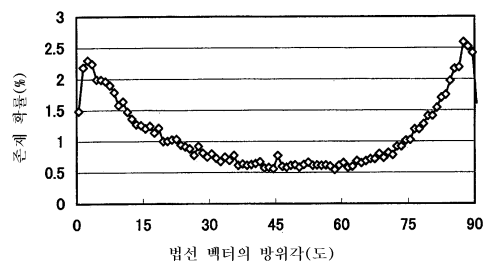

14

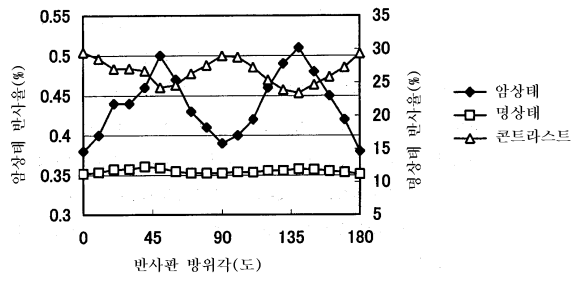

15

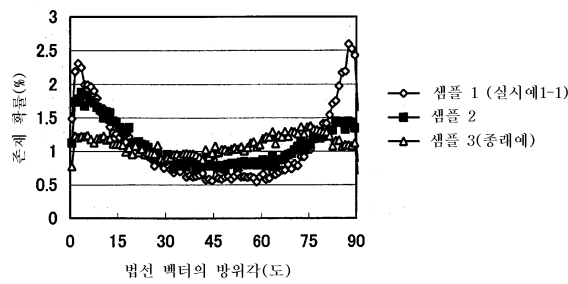

16

	표준편차	비고
샘플 1	0.56	실시에 1-1의 요철 형상
샘플 2	0.32	
샘플 3	0.10	종래에

17

	최대치	최소치
샘플 1	29.5	23.4
샘플 2	26.8	24.2
샘플 3	25.1	24.7

18

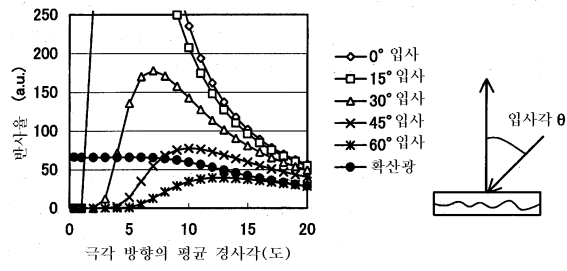

19

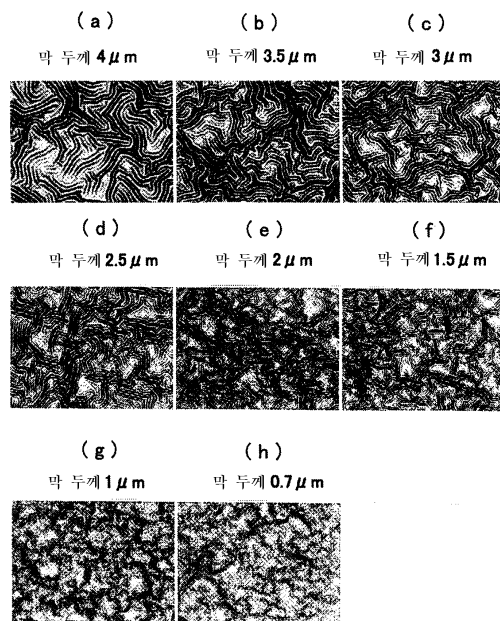

20

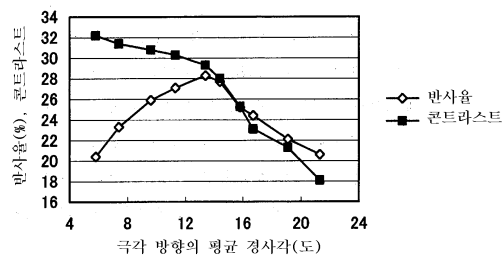

21

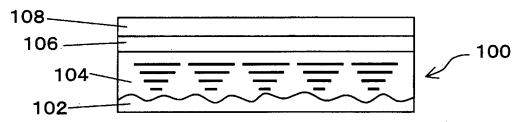

22

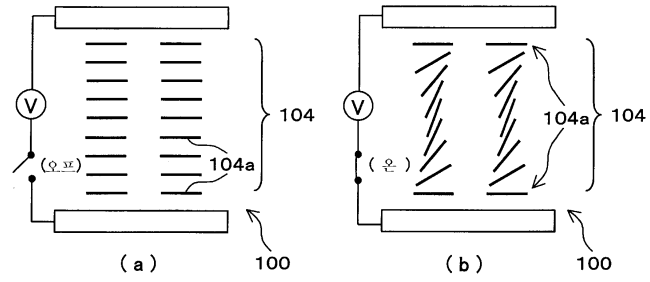

23

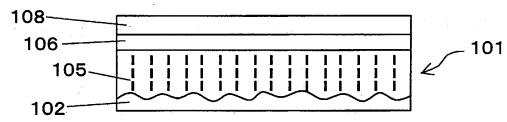

24

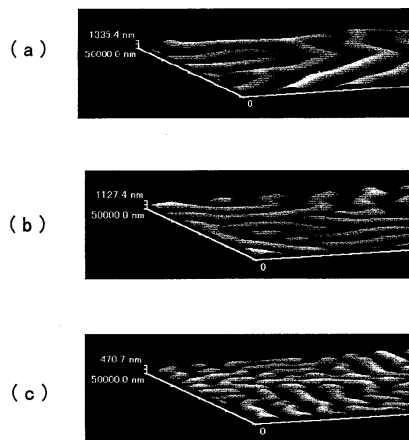

25

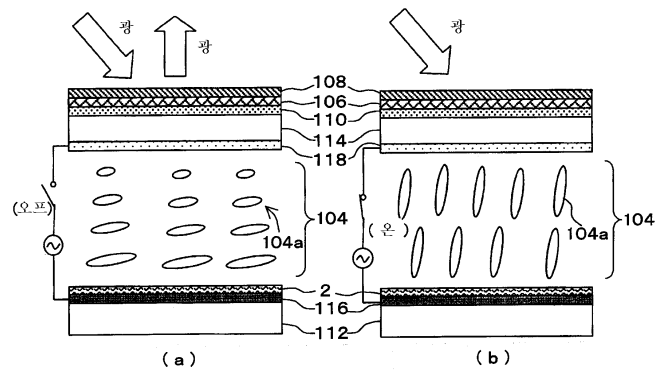

26

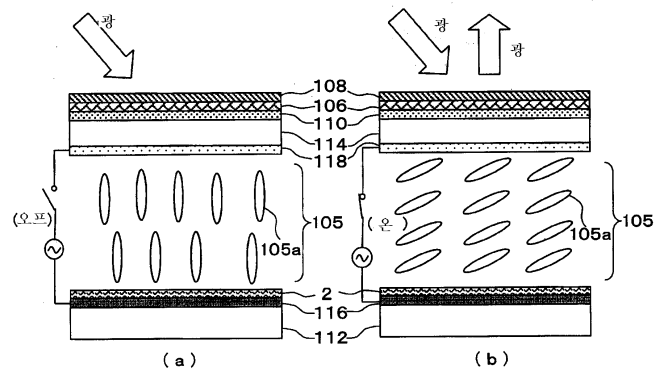

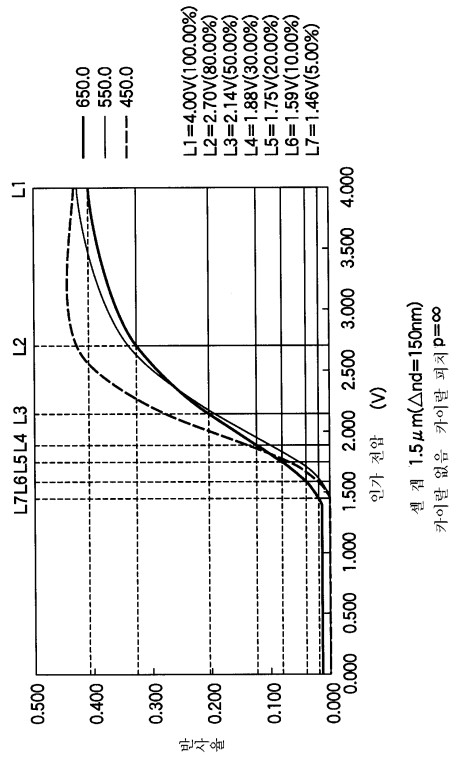

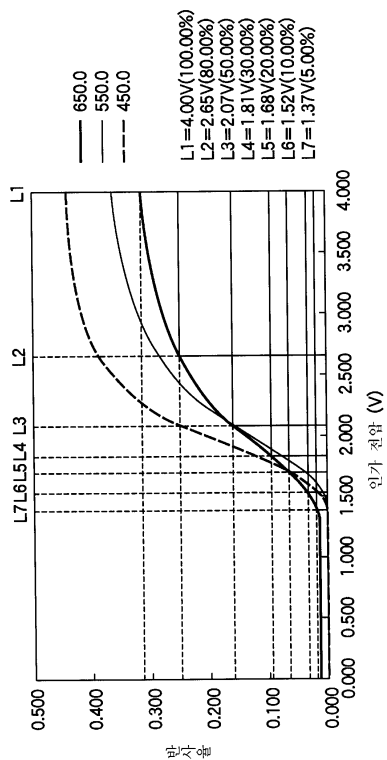

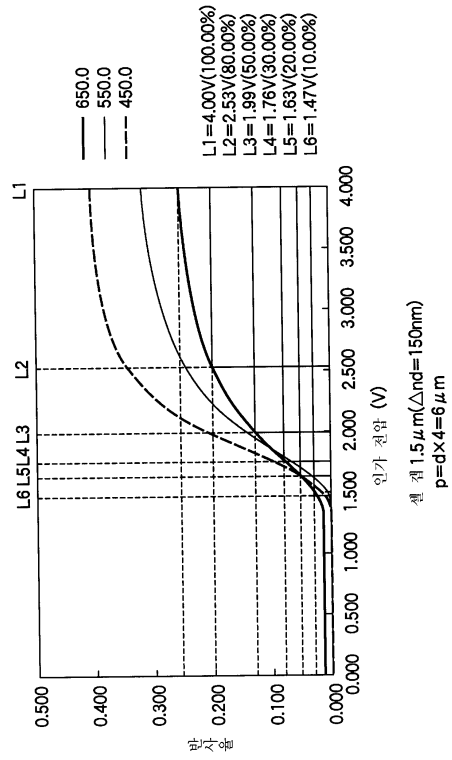

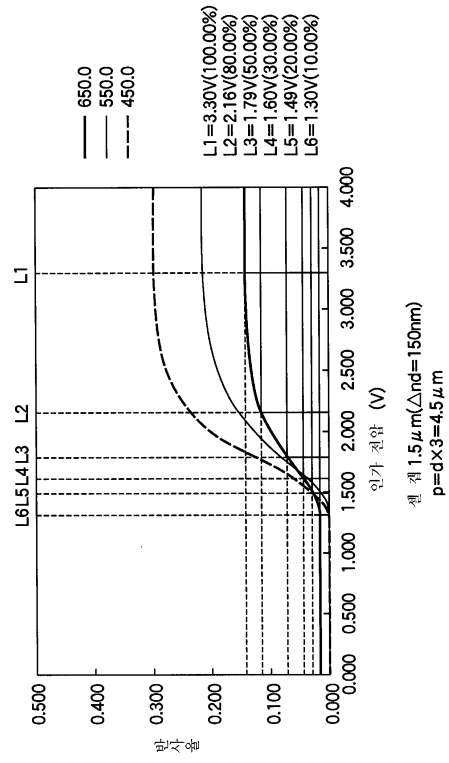

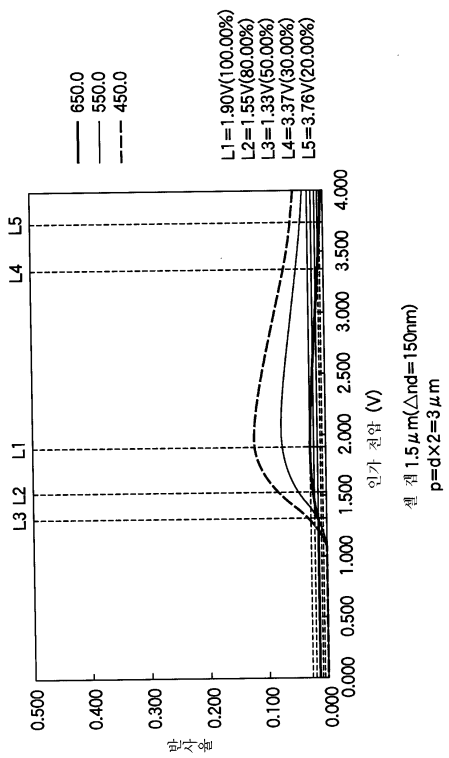

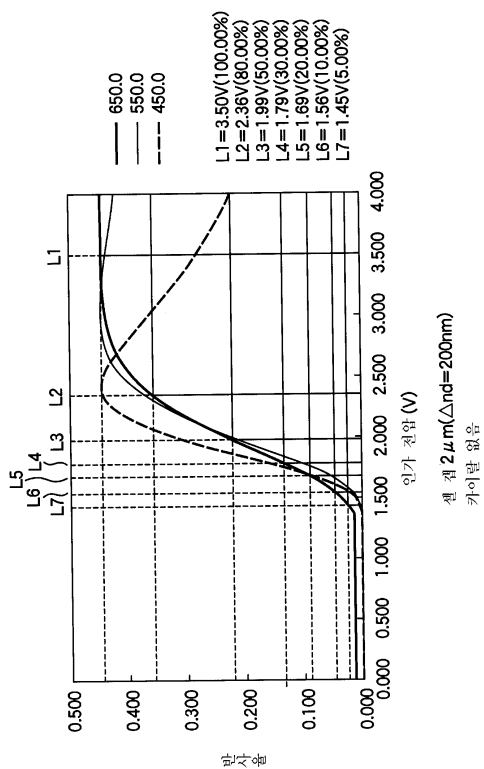

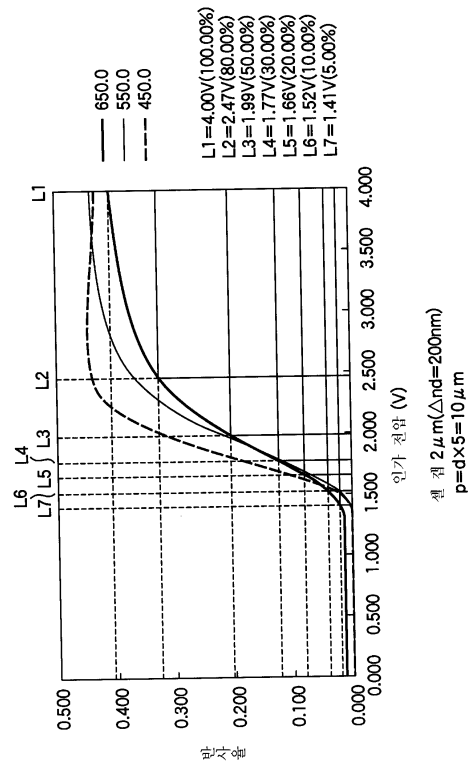

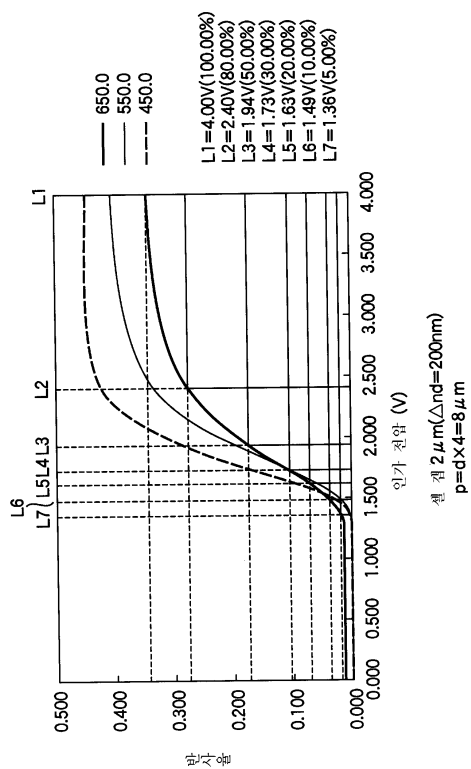

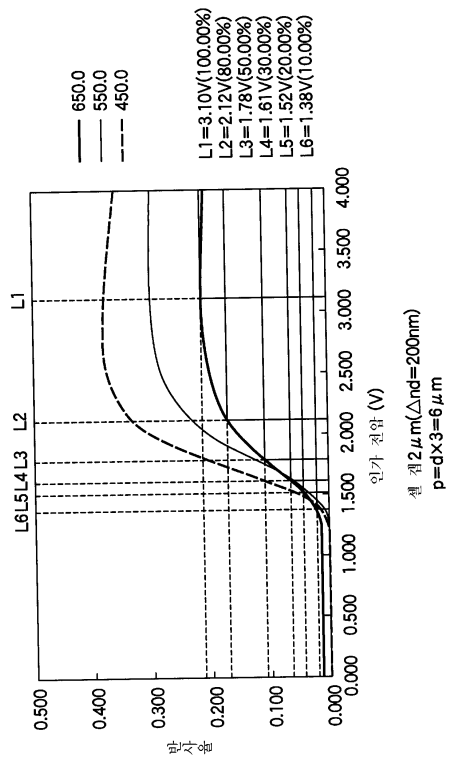

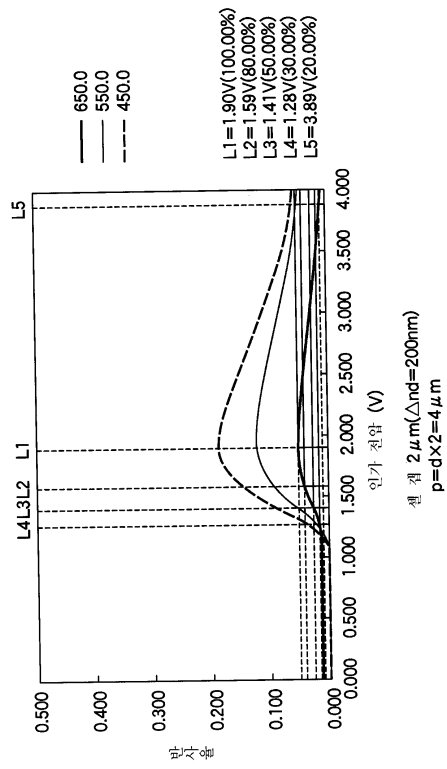

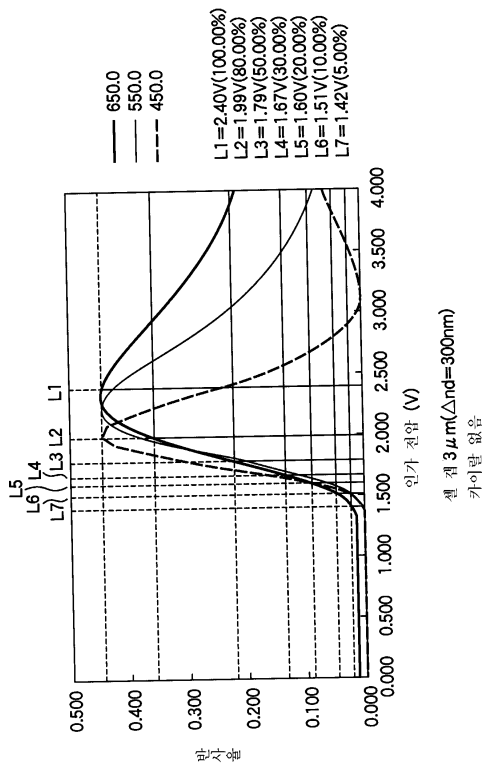

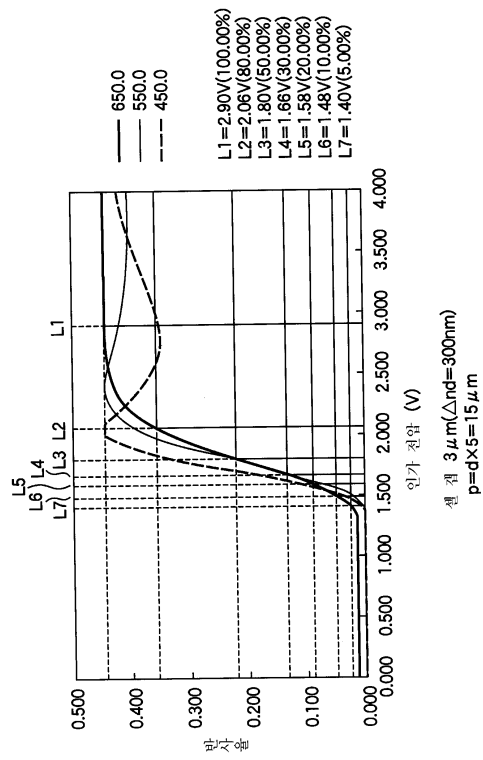

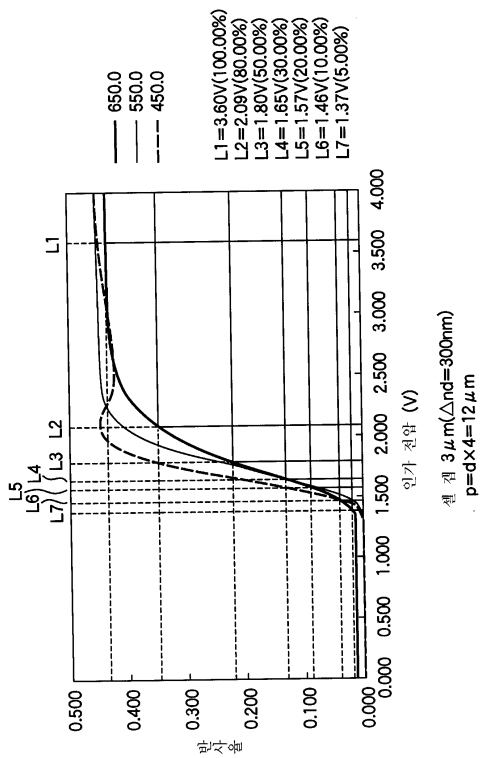

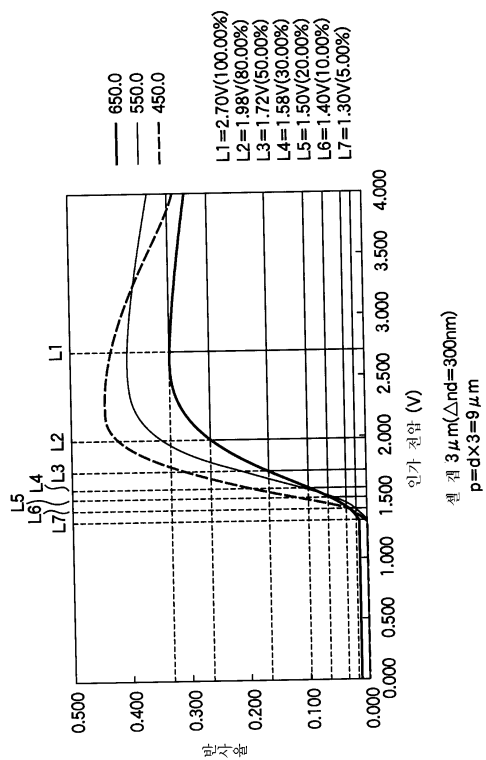

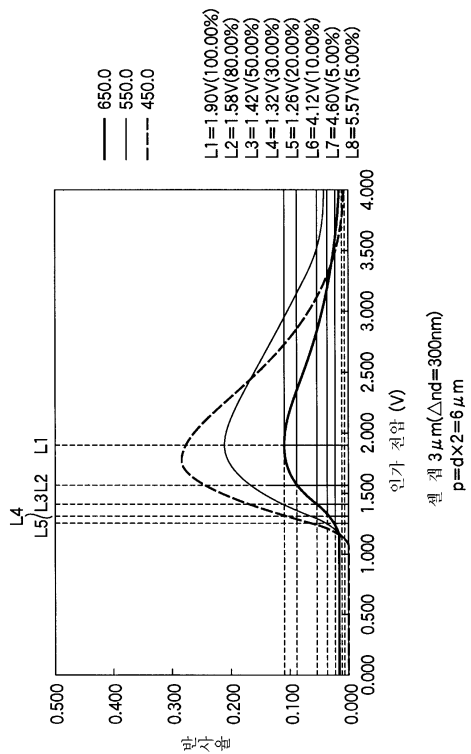

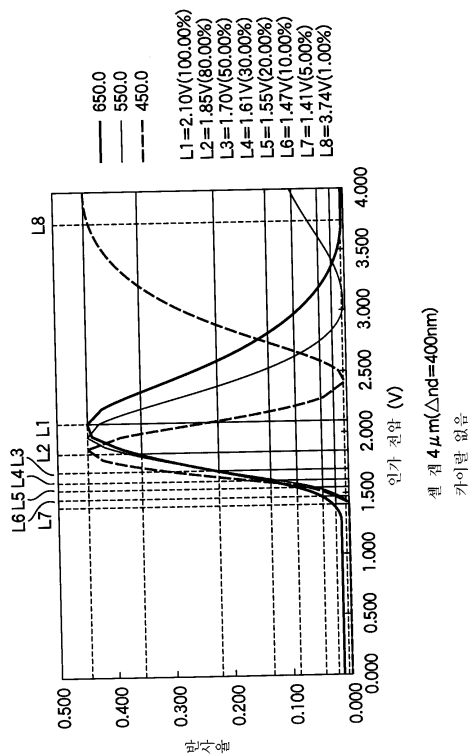

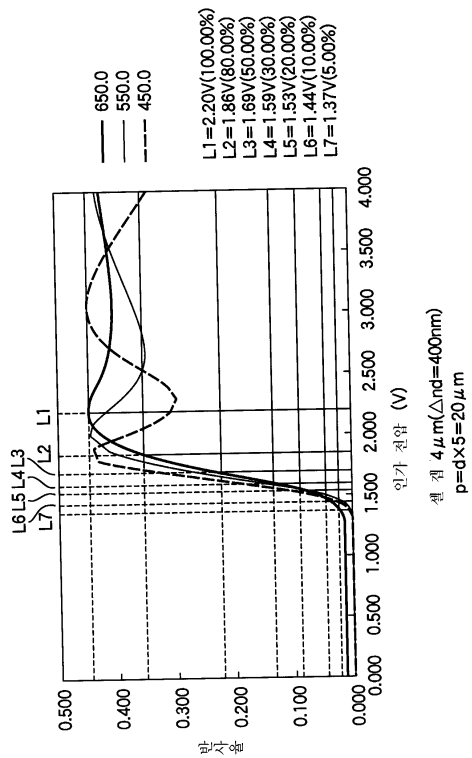

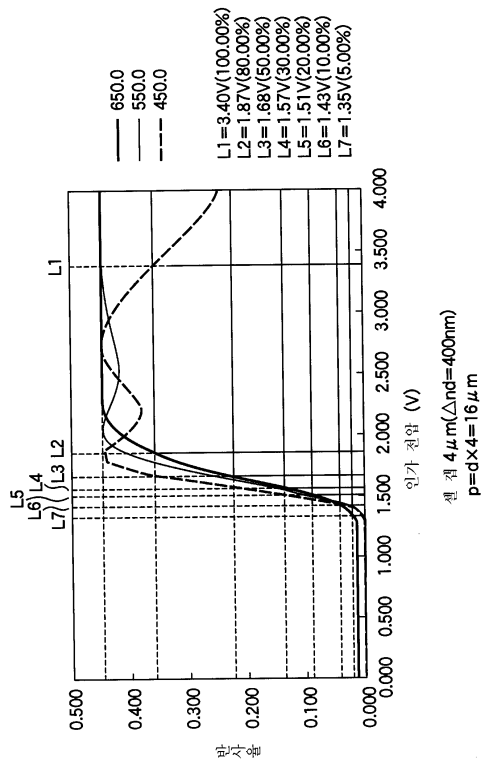

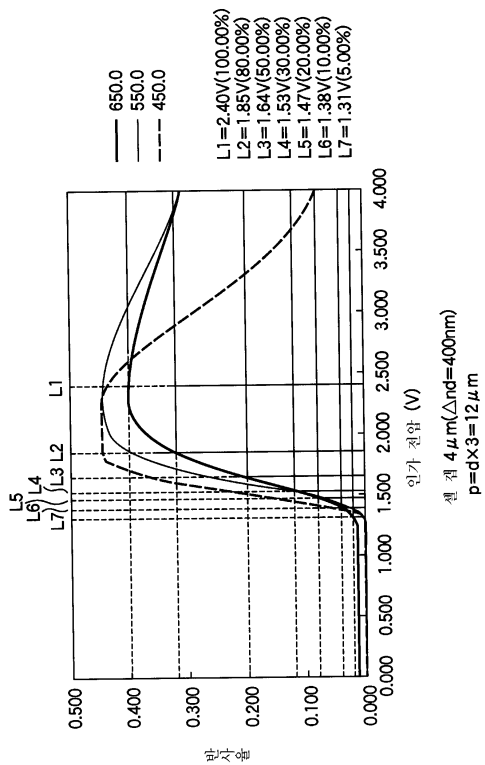

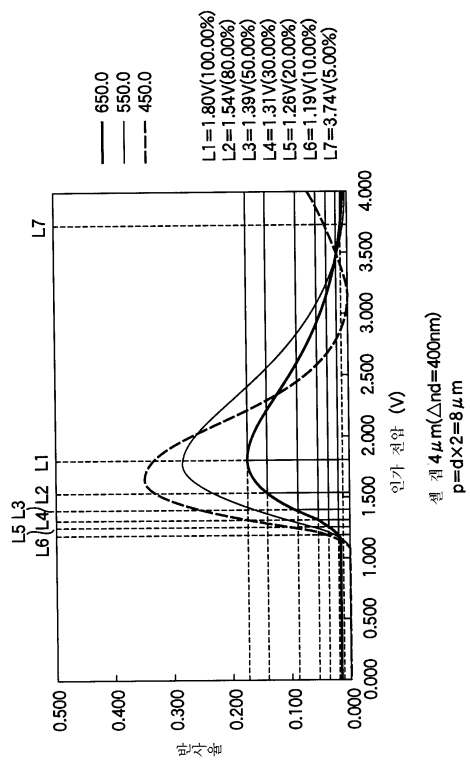

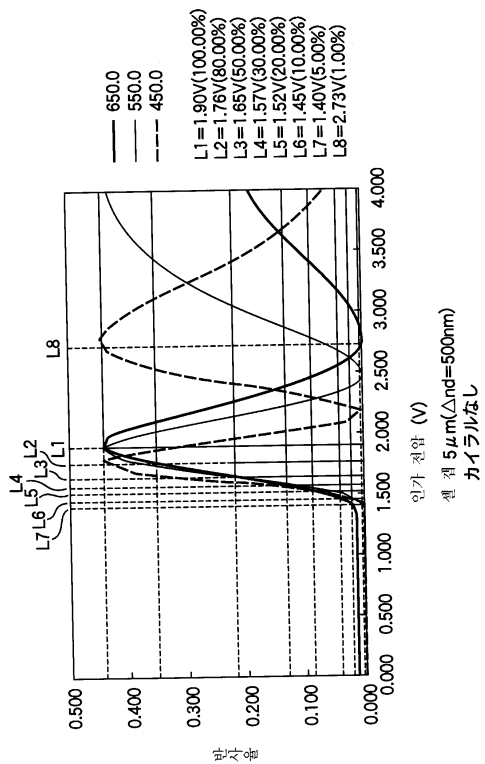

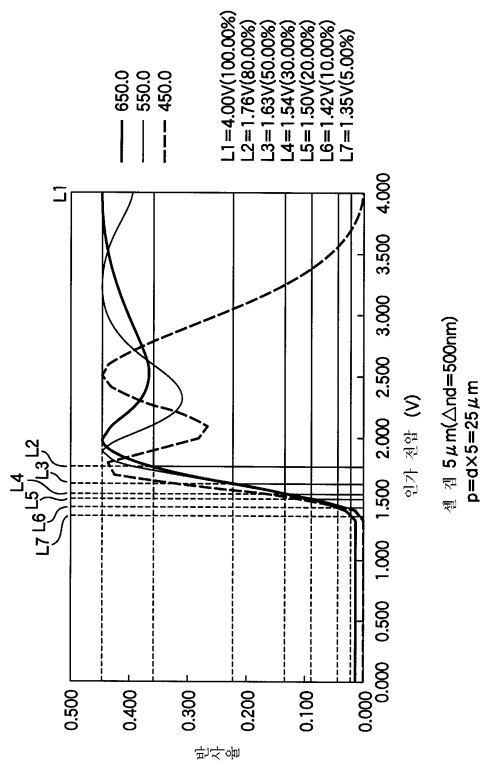

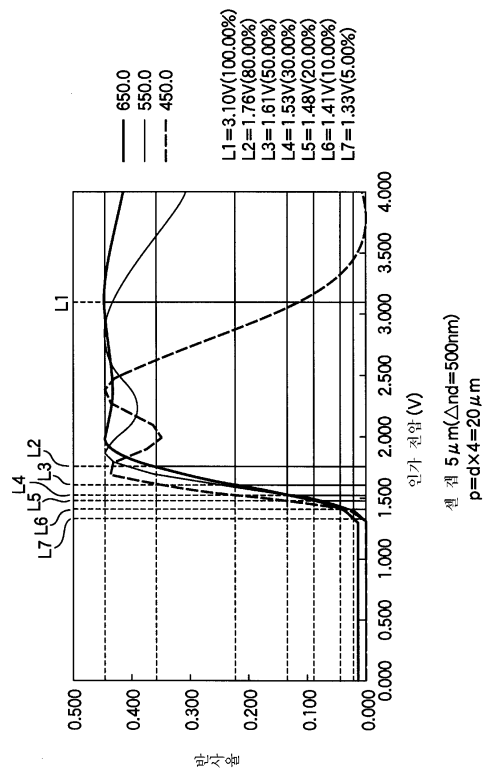

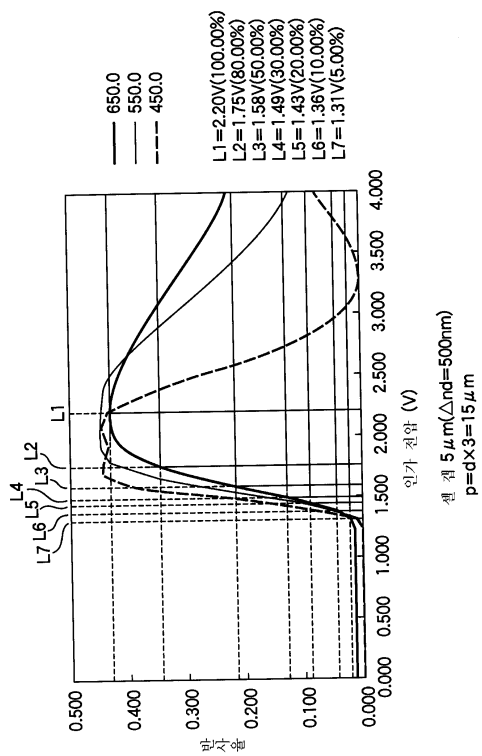

51

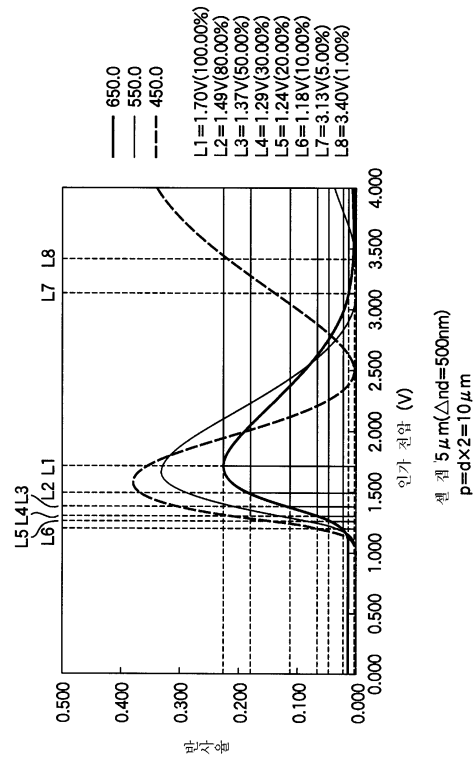

52

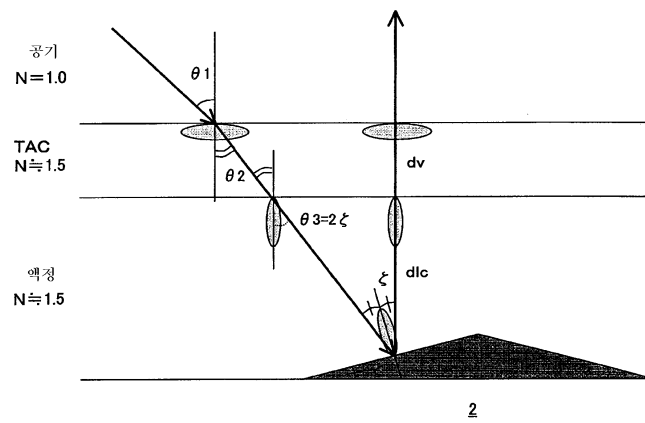

53

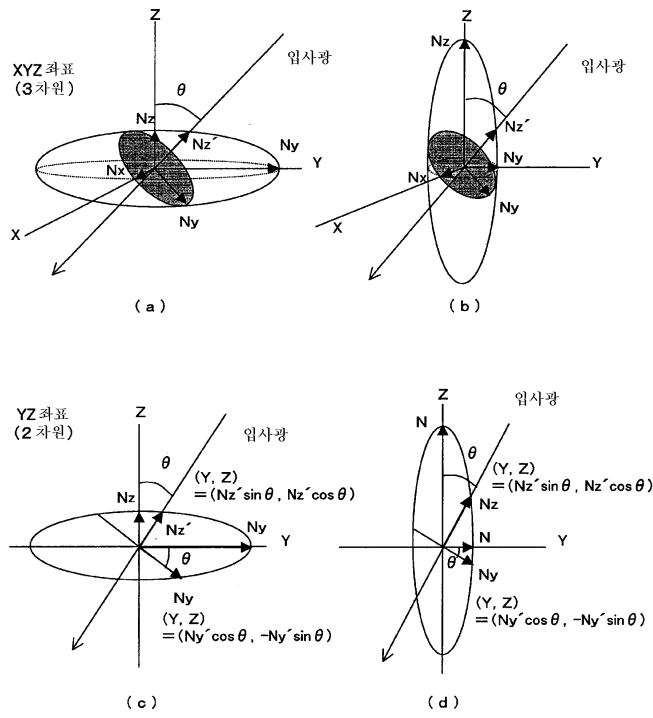

54

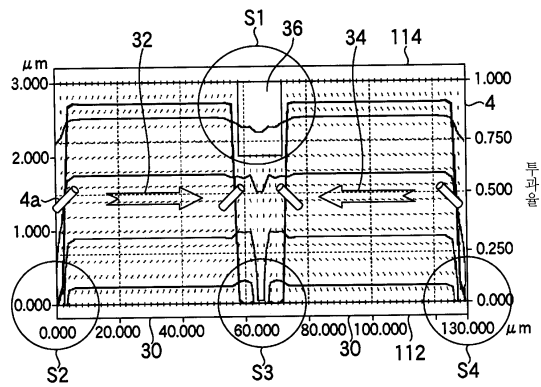

55

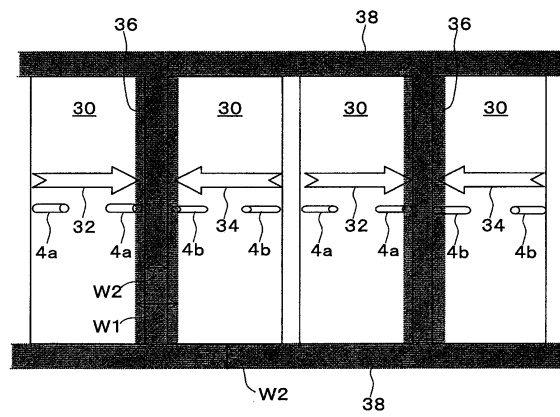

56

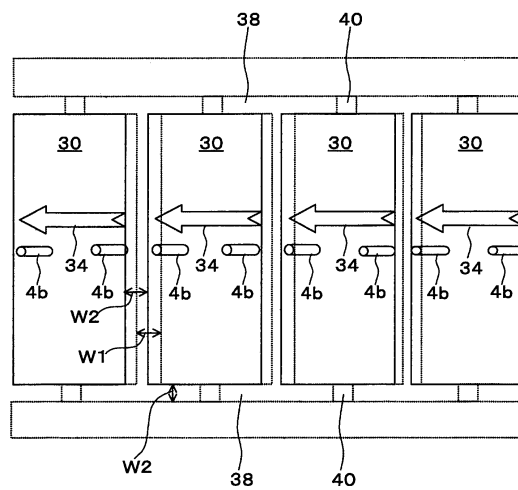

57

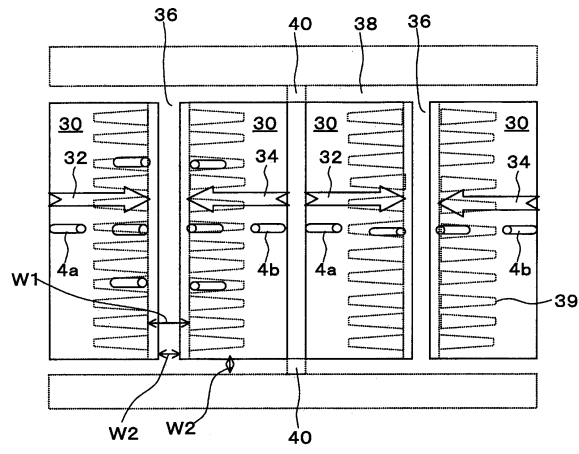

58

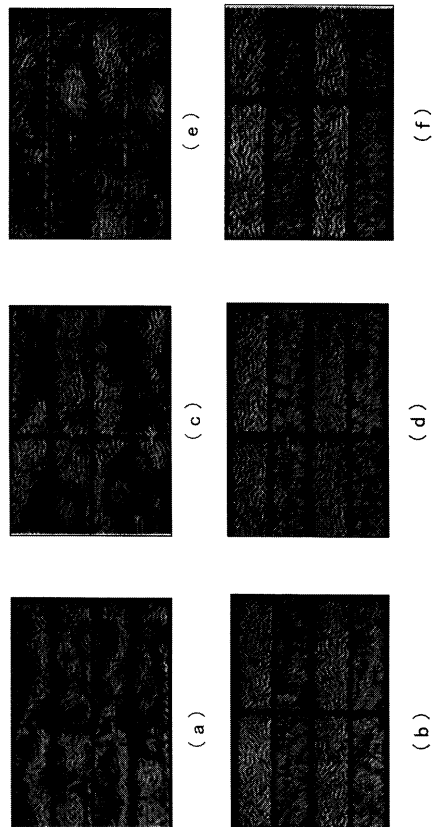

59

(a)

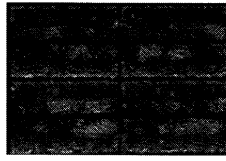

(b)

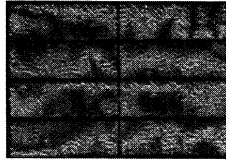

专利名称(译)	反射型液晶显示装置基板和使用其的反射型液晶显示装置		
公开(公告)号	KR1020030031401A	公开(公告)日	2003-04-21
申请号	KR1020020027417	申请日	2002-05-17
[标]申请(专利权)人(译)	夏普株式会社		
申请(专利权)人(译)	夏普株式会社		
当前申请(专利权)人(译)	夏普株式会社		
[标]发明人	SUGIURA NORIO 스기우라노리오 OHMURO KATSUFUMI 오무로가츠후미 TASHIRO KUNIHIRO 다시로구니히로		
发明人	스기우라노리오 오무로가츠후미 다시로구니히로		
IPC分类号	G02F1/1333 G02F1/1337 G02B5/08 G02B5/02 G02F1/139 G02F1/13363 G02F1/1335 G02F1/1343		
CPC分类号	G02F1/133504 G02F1/1337 G02F1/133553 G02F1/1393		
代理人(译)	MOON, KI桑		
优先权	2001317500 2001-10-15 JP		
其他公开文献	KR100787899B1		
外部链接	Espacenet		

摘要(译)

本发明的目的是提供一种用于反射型液晶显示装置的基板，该基板可用于反射型液晶显示装置，而高对比度的基板则是高反射率的，因为本发明涉及反射基板。在使用介电各向异性的VA模式的反射型液晶显示装置中以实惠的价格使用的型液晶显示装置是它包括的可否认液晶和具有凹凸形状的漫反射板。由于配备有具有反射表面的光反射板(2)的反射型液晶显示装置的基板是凹凸形状，因此当假设反射表面由多个微反射镜(26)组成时，标准偏差为微镜(26)的法向矢量(I_n)方向存在于距方位角 ϕ_n 的 $\phi_n + 1^\circ$ 的角度范围内的概率分布包括为大于0.1。用于反射型液晶显示装置的基板，反射型液晶显示装置，微镜，宝丽来膜，相位差板。

