

(19)
(12)

(KR)
(A)

(51) 。 Int. Cl.7
G02F 1/1335

(11)
(43)

10-2004-0054425
2004 06 25

(21) 10-2002-0081460
(22) 2002 12 18

(71) . 20

(72) 501 105

(74)
:

(54)

4

1

2

3a 3b

4 2 A

5

TFT

6

TFT

(240, 250) (matrix) (data pad)가 , TFT (200) 가 (gate pad) (Vcom) 가

(210) TFT (200) , TFT (200) (Cr) RGB 가 (210) ITO(Indium-Tin-Oxide) (Vcom) 가 (Ag dot)

(200, 210) (spacer) (200, 210) (gap) (210) 가 1 (sealant) (230)가 , 가 1 (230) (A) (200) 가 (240) 5 2 TFT (240)가 (200) (A) 3a 3b

(300) (310) TFT(350)가 (300) (switch) , (310) (drain) (330) (frame) (Clc) TFT(350) 가 (storage-on-gate) TFT(350) (Ct) (Cs+Clc) 가 (320) (310), (300), TFT(350) (330) 가 (340) (210) 2 (360)가

TFT(350), (300), (310), (320) (320) 2 (360) (d1) TFT(350), (300), (310), (320) (photolithography) (margin) (simulation) (360) (design rule) 가 (330) (300) 가 가 2 (330) 가 (360) TFT (200) (210) 가 2 (360) 3b (d2)

TFT (200) (210) 2 5μm (360)가 5μm (330) 5μm (330) 가

4 2 A 1 5 (240a, 240b, 240c, 240d, 240e)가 (240a, 240b, 240c, 240d, 240e) (330) 2 (360)

(57)

- 1. 1 ;
1 ;
1 ;
1 ;
1 ;
2 2 ; 2 2 1
2 2 ; 2 1 ;
2 2 ;
1 가 2 2
2. 1 , ,
가
3. 1 , ,
1 1
4. 1 , 2 1μm
5. 1 , ,
가
6. 1 , ,
가
7. ;
;
;

7 8.

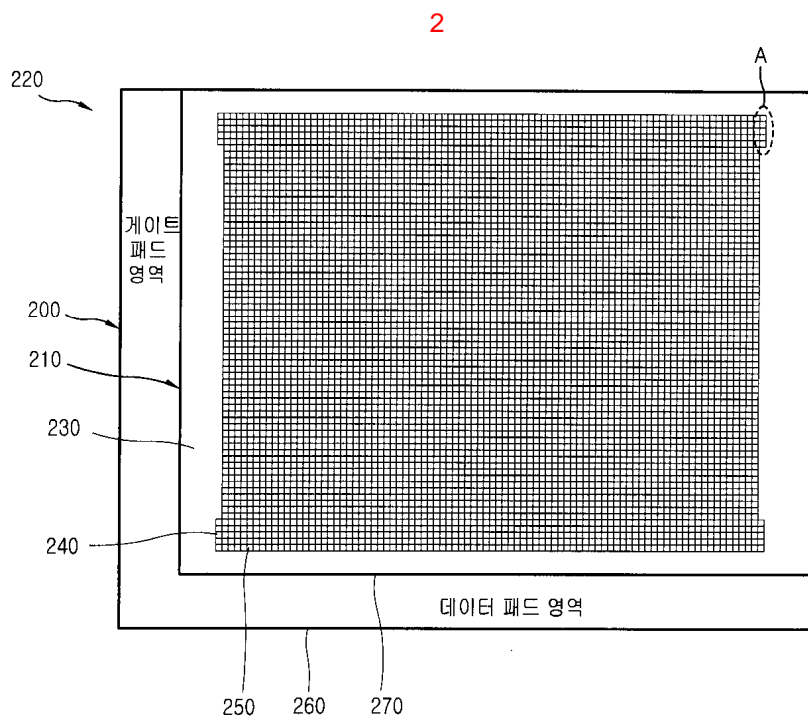
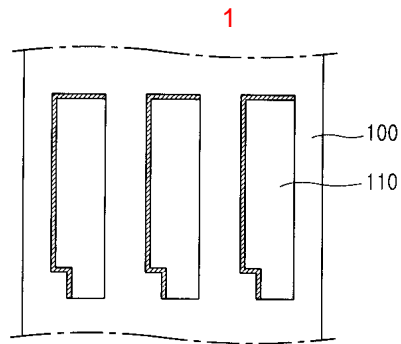

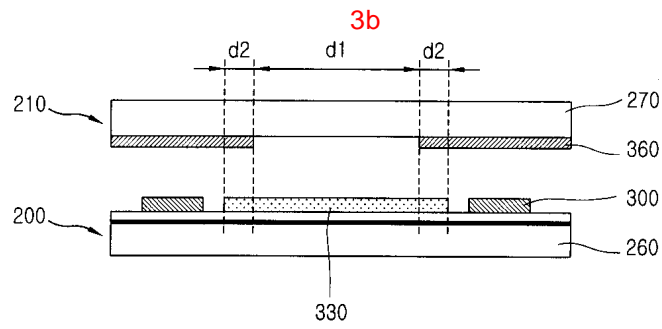
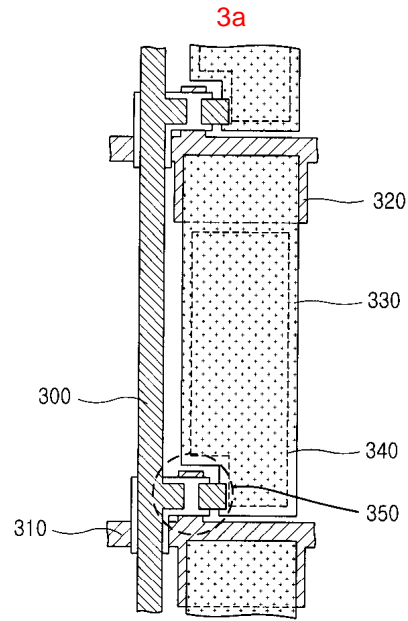

4

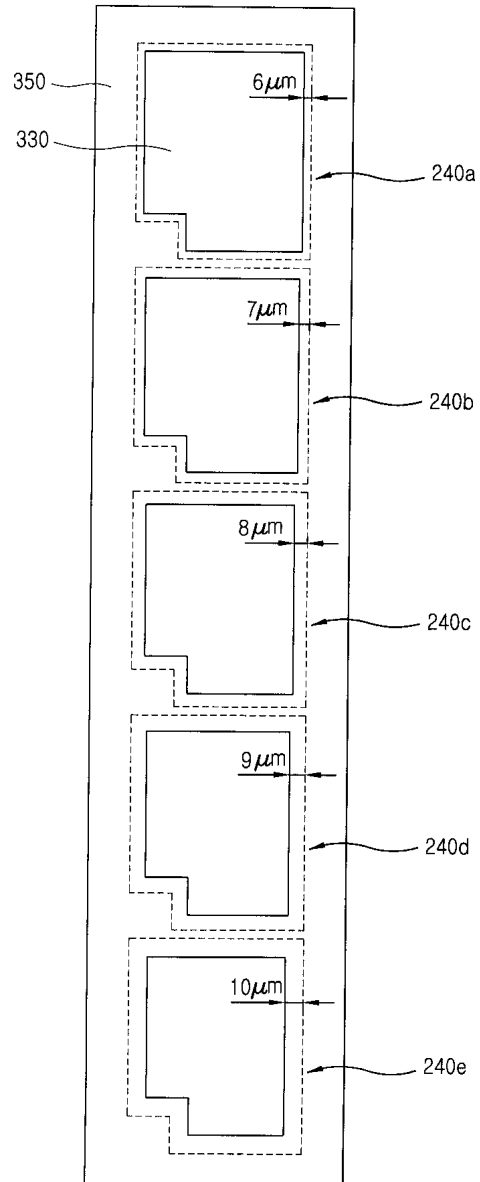

5

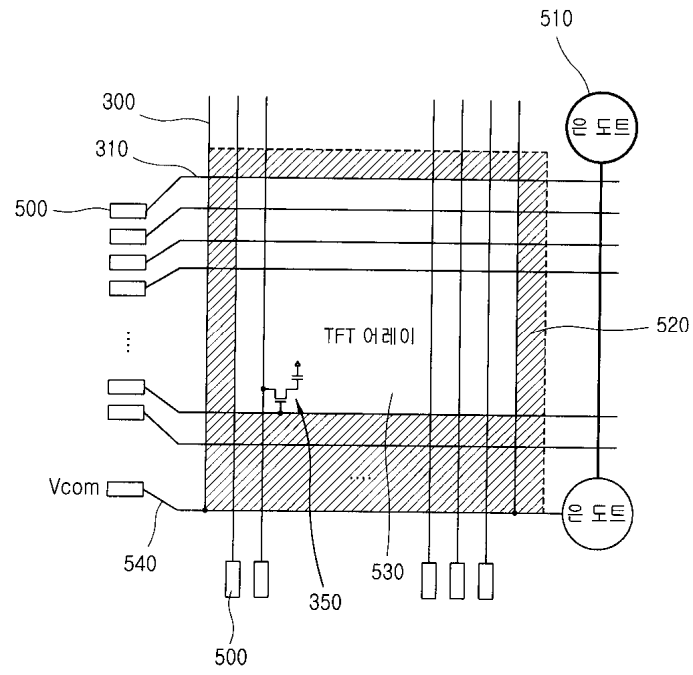

6

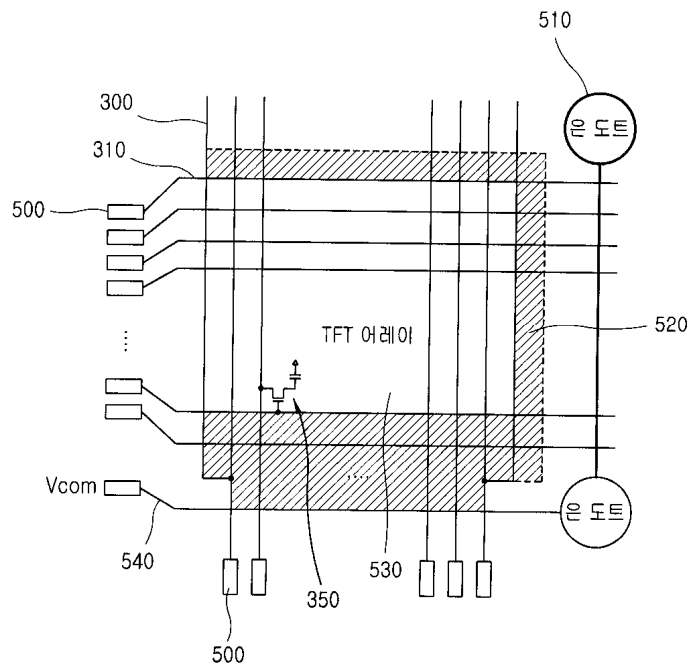

专利名称(译)	使用液晶显示装置制造能够容易地观察漏光现象的液晶显示装置和最佳宽度的黑矩阵		
公开(公告)号	KR1020040054425A	公开(公告)日	2004-06-25
申请号	KR1020020081460	申请日	2002-12-18
[标]申请(专利权)人(译)	乐金显示有限公司		
申请(专利权)人(译)	LG显示器有限公司		
当前申请(专利权)人(译)	LG显示器有限公司		
[标]发明人	LIM JOOSOO 임주수		
发明人	임주수		
IPC分类号	G02F1/1335 G02F1/13		
CPC分类号	G02F1/133512 G02F1/1309		
代理人(译)	PARK , JANG WON		
其他公开文献	KR100662780B1		
外部链接	Espacenet		

摘要(译)

目的：提供一种LCD装置，包括在LCD面板的虚设区域中具有不同重叠宽度的透明电极和黑矩阵的多个测试像素，从而精确地观察漏光以进行旋错。

