

(19)
(12)

(KR)
(A)

(51) 。 Int. Cl.7
G02F 1/13

(11)
(43)

10-2004-0095047
2004 11 12

(21) 10-2003-0028644
(22) 2003 05 06

(71) . 20

(72) 630 108 202

112 403

4 205 501

204 1202

(74)

:

(54)

(jig)가

가

가

1
2
3
4
5
6
7
8
<
1 :
3 :
5 :
7 :
11, 17 :
13 :
15 :
18, 26 :
20, TFT :
22 :
30 :
34 :
36 :
40 :
401, 402, 405 :
404 :
702, 802 :

4
4

가
가

가
가

가
가

가
가

가
가

가
가

가
가

가
가

가
가

가
가

>

2 :

4 :

amp;

8, 23 :

12 :

14 :

16 :

19, 28 :

21 :

24 : H

32 :

35 :

-

400 :

403a

403d :

701, 801 :

T1

T4 :

C1, C2 :

Clc :

Cst :

(jig)가

(Cathode Ray Tube)

가

(Flat Panel Display)가

D),

(Liquid Crystal Display : LCD),
(Plasma Display Panel : PDP)

(Field Emission Display : FE
(Electroluminescence : EL)

(Thin Film Transistor : 'TFT')

(23) 1 (15) (22) TFT

2) (22) (11) (12) (13) (R), (G) (B) (14) (1) (13)
(Black Matrix)가 가

TFT (23) (16) (19) (18) (18) (19) (18) (19) (19)
TFT (20) (21) TFT(20) (18) (21) TFT (23)
(21) (17)

(15) 가 TFT (23)

(15) (22) TFT (23) (11,17) 90° TN

(22) TFT (23)

(Repair)

TFT

/ TFT
 / (Sealant) TFT
 Tape Carrier Package : , 'TCP') 가 ((Chip On Glass ; , 'COG') (Tape Automated Bonding) TFT
 TFT / TFT 가
 가 가 가 가 가
 377,030 2 가 2 5,
 2 (32) (38) (35) (36) (24) TF
 T (46) (28) (32) (34) , H (30) , (4
 6) (35) TFT (46) (26) V (42) , TFT (4
 T (46) (28) (26) , TFT , TF
 T (46) (33) , (33) TFT (Cst)가
 T (46) T (46)가 (load) , T (46) (writing) T (46) (reading)
 T (46)가
 4) (32) (30) (34) 1 (34a) (30) H (2
 (42) (35) T (46) (28) (34), V
 (Cst) T (35) - (turn-on) (28) (26) T T
 4) (26) (34) 2 (34b) (30) H (2
 (Cst) T (28), (30), T (35) - (turn-on) (32), (3
 4) (38) (38) (40) , (40) - (Cst) - T
 (46) (40) (38) T (46)가 (32),
 (34), (35), H (24), V (42), (30), (32),
 가 (36), - (38), (40) T (46)가 (32),
 2 가 가

가 TFT (46) (26) (28)
가

, 가 .

, 가 가 ; - ; - , .

가 가 ; - ; .

2 TFT . - 1 TFT ; 1 TFT -
1 가 ; 1 TFT 2 TFT 가
2 2 TFT 1 2 TFT

2 TFT ;
1 TFT 2 TFT .
2 TFT

2 TFT 1 TFT 2 TFT
4 TFT . - 3 TFT ; 3 TFT -

(DGL, GL1 GLn) TFT (DGL, GL1 GLn) (DGL) TFT
 TFT (GL1 GLn) TFT (DL1 DLm)
 TFT (Cst) 가 - (DL1 DLm)
 (Cst) (Cst) TFT , TFT
 . 3 amp; (3) (Cst) (point defect)
 (GL1 GLm) (DL1 DLm) (short) (open)
 (Device for protecting a electrostatic discharge damage : 'ESD ') (403a
 403d) 가 ('ESD ')
)(404) TFT . ESD
 (404) (GND) (Vcom)
 , TFT TFT 가 가 1 3
 (401, 402, 405) , 1 (401) 가 1 3 TFT(T1, T3) , 2
 (402) TFT (GL1 GLn) 2 TFT(T2) , 1 2 TFT(T1,
 T2) 4 TFT(T4) , 3 (C1) , 3 (405) TFT (DL1 DLm)
 (C2)
 1 (401) 1 3 TFT(T1, T3) (Vg-off)
 2 (402) 2 4 TFT(T2, T4) (Vg-on)
 3 (405) (Vds) (DL1 DLm)
 (Vcst) 3 (405)
 1 TFT(T1) 1 (401) 2 (402) 1 TFT
 (T1) (C1) 1 TFT(T1) (1) (Vg-on)
 (C1) (Photo current) - 2 (402)
 2 TFT(T2) (C1) 2 (402) 2 TFT(T2)
 - (G1 Gn) 2 (G1 Gn) (C1)
 (G1 Gn) TFT - (Vg-on) (G1 Gn)
 3 TFT(T3) 1 (401) 2 (402) 3 TFT
 (T3) (C2) 3 TFT(T3) (1) (Vg-on) (C2)
 - 2 (402)
 4 TFT(T4) (C2) 3 (405) 4 TFT(T4)
 - (DL1 DLm) 4 TFT(T4) (C2)
 (DL1 DLm) 3 (403) (Vds) (DL1 DLm)
 (Vcst) 3 (405)
 4) (C1,C2) 1 3 TFT(T1,T3)가 - 2 4 TFT(T2,T4)

TFT (Vds) (writing) TFT TFT (reading) , TFT

4 TFT 5

5 Vds (1) (1a) 3 (405) 3 amp; (6) (

(C1) 1 TFT(T1) 2 (402) (Vg-on) 3 TFT(T3) 2 TFT(T2) (GL1 GLn)

(C2) 3 TFT(T3) 3 (405) (Vds) (DL1 DLm) 4 TFT(T4)

(Cst) (GL1 GLm) TFT (Cst) (Vds) (DL1 DLm) (405), (

DL1 DLm) TFT (i) 3

T1, T3) (1) (1a) TFT 1 3 TFT (T1, T3) (1a) 1 3 TFT (

6

6 1a) 1 TFT (T1) 3 (405) 3 TFT (T3) 가 (1) (

TFT(T1) 2 (402) (Vg-on) 2 TFT(T2) (C1) 1

3 TFT(T3) (DL1 DLn) 3 (405) (DGL, GL1 GLn) (C2) .

GLm) (i) TFT (Cst) (DL1 DLm) (GL1

3 (405) (i) (Cst) (Vcst) TFT, (DL1 DLm) (DL1 DLm)

amp; (6) amp;

(3) amp; (6) TFT amp; (3) (Vcst) amp; (DL1 DLm) (GL1

TFT GLn) (4) , TFT amp; (3) (Vcst)

T1 T4), (400) TFT 가 가 , 1 4 TFT (

TFT (C1, C2), 1 3 (401, 402, 405) TFT (Clc) 7

(702) / (701) (DL1 DLm)

(702)

(701) (Gate start pulse)

(GL1 GLn)

2, 405) TFT 1 4 TFT (T1 T4), (C1, C2), 1 3 가 (401, 40

TFT (T1 T4) 8 TFT (T1 T4) (Clc) (803)

(802) / (801)

TFT

TFT
TFT

TFT

TFT,

TFT
TFT

가

가

(57)

1.

가

가

;

2.

1

3.

가

가

;

4.

3

5.

4

3 **6.** ,
 ,
 - 1 ;
 1 - 2

6 **7.** ,
 ,
 가 1 1 ; 1
 2 가 2 1 2 .

7 **8.** ,
 ,
 2 ;

8 **9.** ,
 1 2 ,
 2

6 **10.** ,
 1 2 2

3 **11.** ,
 ,
 - 3 ;
 3 - 4

12.

11 ,

,

가 3 1 ;

3

4 2 ;

3

가

4

가

3

13.

12 ,

,

4 ;

14.

13 ,

3 4 ,

4

15.

11 ,

3 4

4

16.

3 ,

17.

3 ,

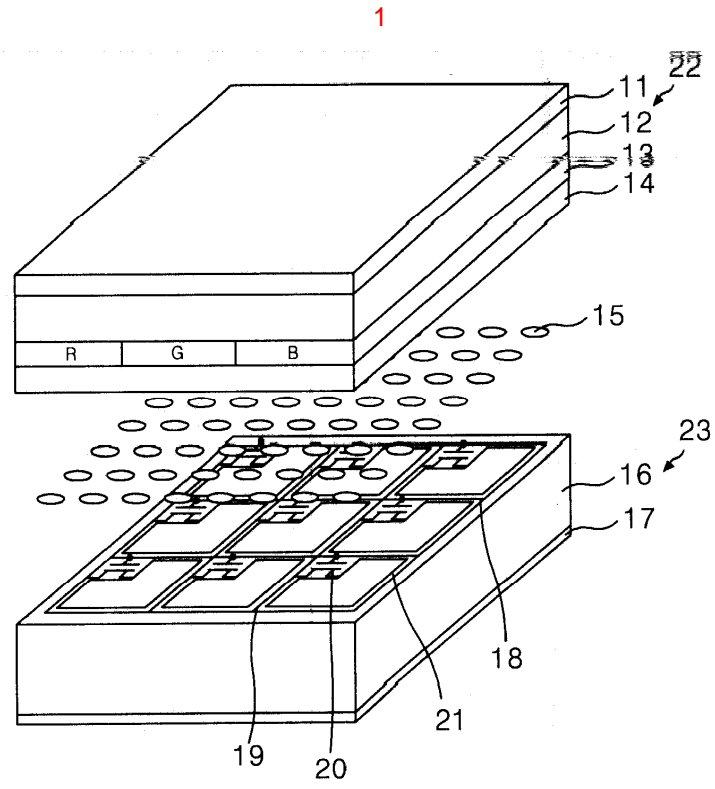

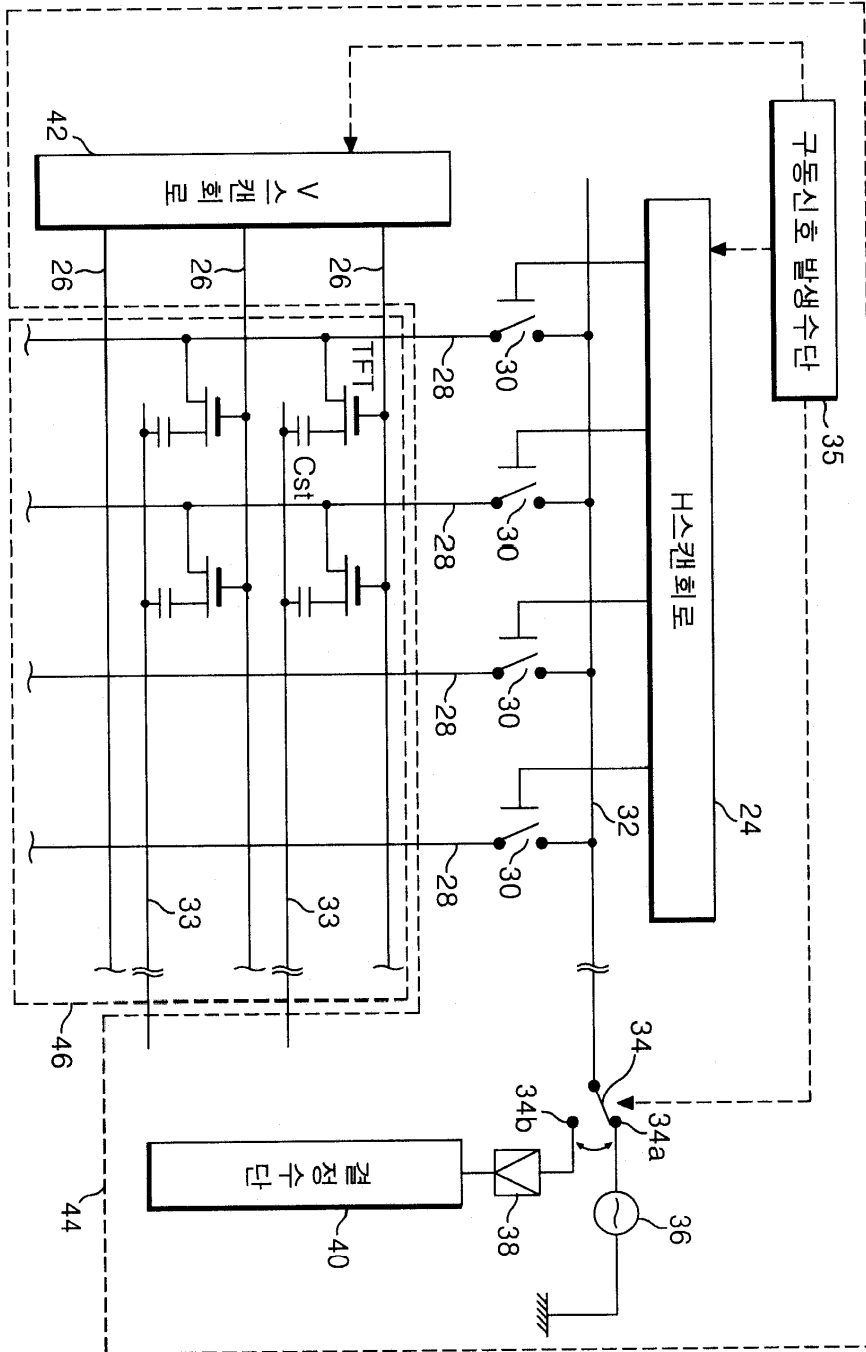

3

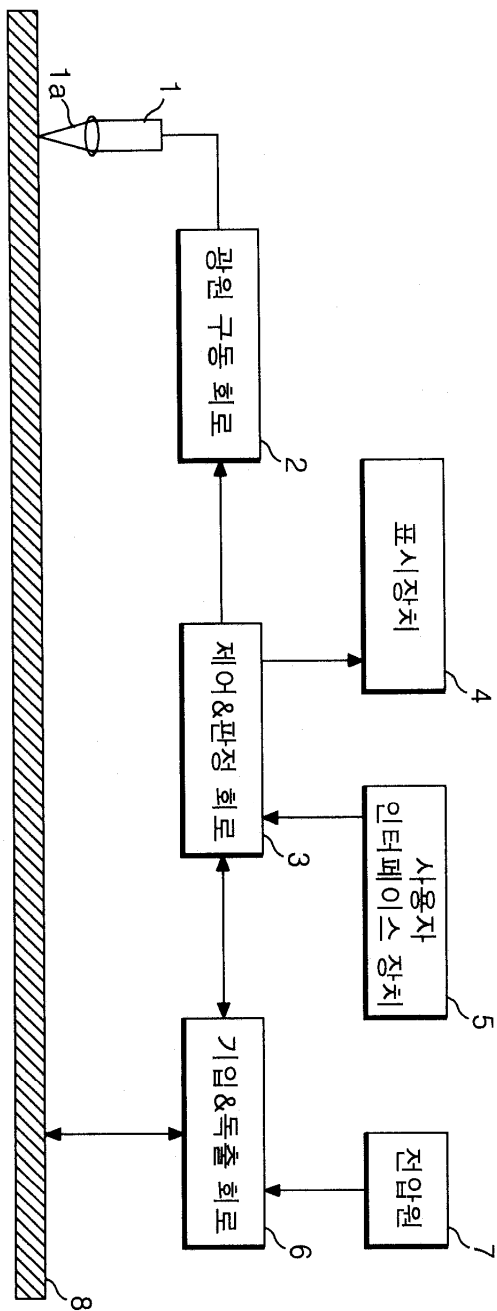

4

