

(19)
(12)

(KR)
(B1)

(51) 。 Int. Cl.7
G02F 1/1333

(45)
(11)
(24)

2004 07 30
10-0442491
2004 07 21

(21) 10-2001-0088585
(22) 2001 12 29

(65)
(43)

10-2003-0058193
2003 07 07

(73) .
20

(72) 710 106 1501

112 105 1210

617 205 1406

328-5

381

(74)
:

(54)

(rubbing)

(seal pattern) (sp

acer)

(scribe) 가 (break)

가 가

1

1 (100) (113) (115) (1

13) (114) (115) (102) (115)

(101) 가 (113) (114) (115)

(113) (113)

가 가 가 가 (113) (101)

(113) (102) (101)

p) (113) 가 (101) (116) (102) - (cell-ga

2 (101) 1 (102)

2 (101) (102)

02) 1 가 (114) (115)가 (101) (1

2 (160) (102) (101) (101)

(dummy region, 170)

60) (101) 1 (150) (102) 2 (1

(160) (102) (170)

(101) (102)

(active region, 180) (180) 가

(190) (160) (102) (170) (margin) 가

2 (180) (190) (102) 가 (de

sign rule) 2 (160) (102) 가 2

(160)

(180) 가 가 3 (190)

가

1 2 ,
 2 1
 , 1 2 ;
 가 2 1 ;
 7 (301) 1 (350) (
 302) 2 (360) (301) (302)
 7 가 1 (101) (102)
 , (114) (115)가
 , (301) (302) (301) (303)
 , 가 (coating)
 , (160) (170) (102) 2 (160)
 (101) 2 가 , 2 (360) 2 (360) (3)
 (102) (302) 가 , 2 (360)
 , 2 5 (180) 2
 (160) (208) (102) (190) 가 , 7
 (302) (301)
 , (380) 2 (360) , (30) (30)
 2) 7 (401), (402), (403), (404), 8 (405) (406)가 (
 407) (406) (301) (302)
 , 8 (401)가 (402) , (402) (4)
 01)가 가 가 , (402)
 , (302) (301) (302) (407)
 , (301) (302) (407)
 , (408) (301) (302) (303)
 , (301) (302) (401)

(57)

1.

2.

3.

4.

5.

6.

1 2 ; , 1 2 2 1 ;
가

7.

6 , ; ;

8.

6 , 1 2

9.

8 , 가

10.

6 , 2

11.

10 ,

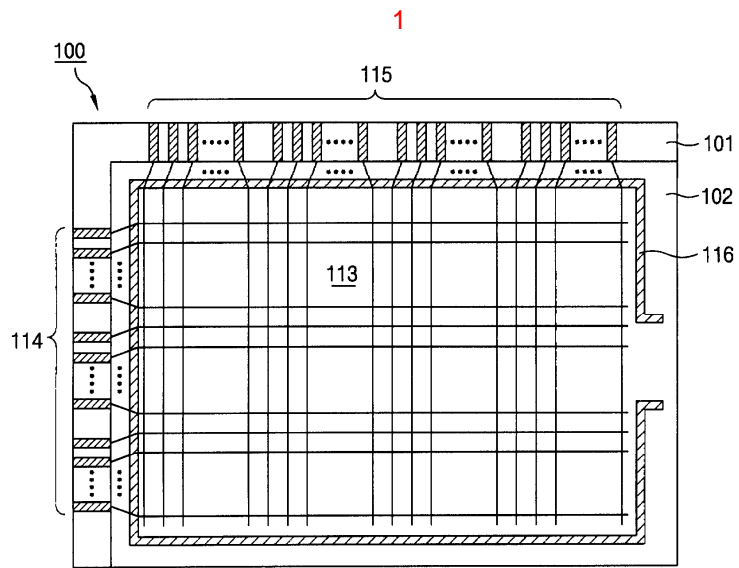

2

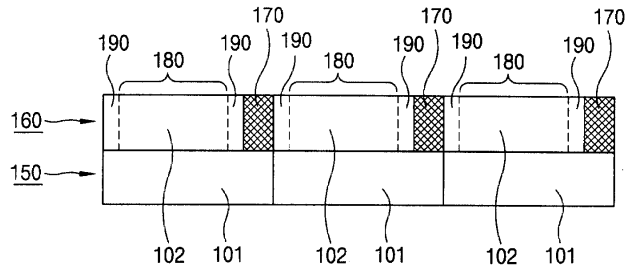

3

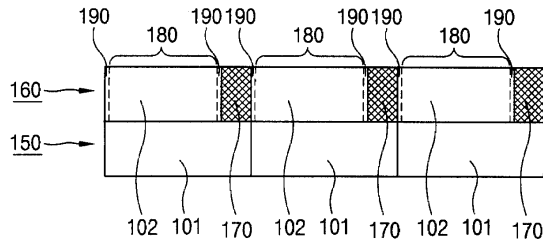

4

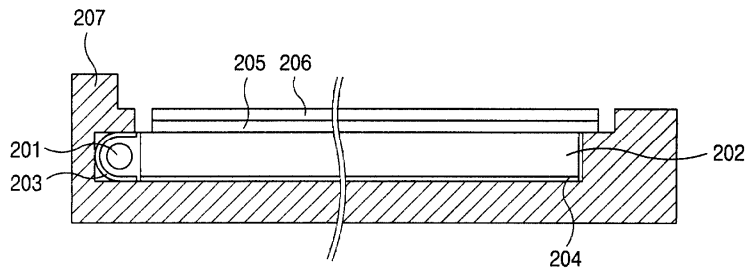

5

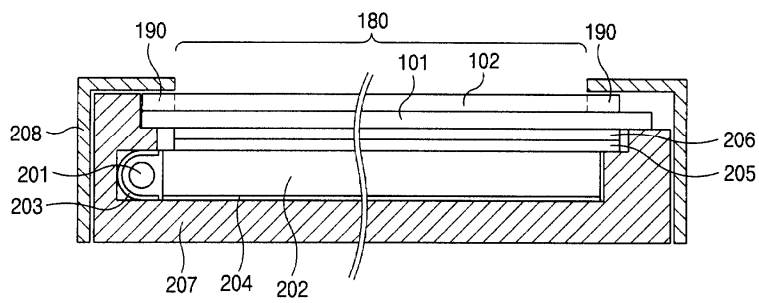

6

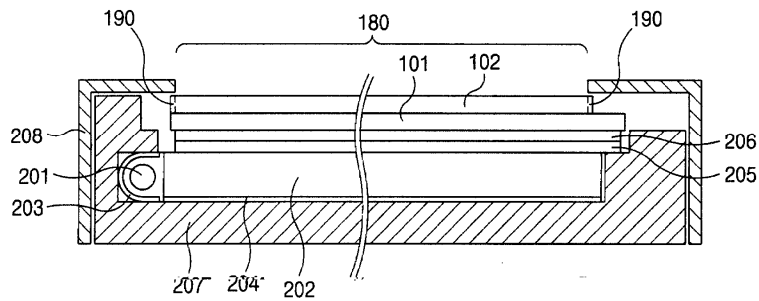

7

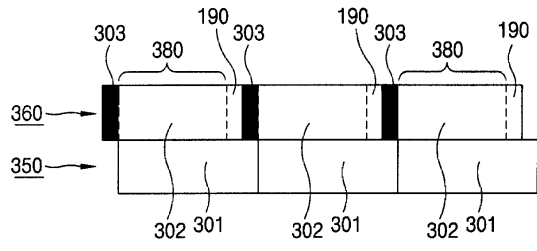

8

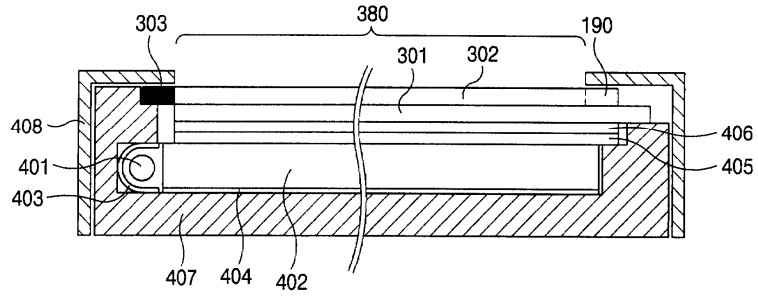

| | | | |
|----------------|---|---------|------------|
| 专利名称(译) | 液晶面板和具有该液晶面板的液晶显示装置 | | |
| 公开(公告)号 | KR100442491B1 | 公开(公告)日 | 2004-07-30 |
| 申请号 | KR1020010088585 | 申请日 | 2001-12-29 |
| [标]申请(专利权)人(译) | 乐金显示有限公司 | | |
| 申请(专利权)人(译) | LG显示器有限公司 | | |
| 当前申请(专利权)人(译) | LG显示器有限公司 | | |
| [标]发明人 | NAM MYUNGWOO 남명우 KIM JUNGROK 김정록 JUNG JUNHO 정준호 KANG KYUNGGYU 강경규 WON SAECHANG 원세창 | | |
| 发明人 | 남명우 김정록 정준호 강경규 원세창 | | |
| IPC分类号 | G02F1/1333 G02F1/13 G02F1/1335 | | |
| CPC分类号 | G02F1/133351 G02F1/133308 G02F1/1333 G02F1/133512 | | |
| 代理人(译) | PARK , JANG WON | | |
| 其他公开文献 | KR1020030058193A | | |
| 外部链接 | Espacenet | | |

摘要(译)

一种液晶面板，包括第一基板和第二基板，其中第一基板相对于第二基板在一侧突出，第二基板在相对于第一基板的相对侧突出。

