

(19) (KR)  
(12) (A)

(51) Int. Cl.<sup>7</sup>  
G02F 1/136

(11)  
(43)

10-2005-0003246  
2005 01 10

(21) 10-2003-0043962  
(22) 2003 06 30

(71) . 20

(72) 2 4 404-302

875 @353-1602

1 221

가 4 108-201

@606-1302

4 885-627/7

(74)  
:

(54)

), (Mo-alloy)

(Mo-alloy) (Cu) .

(Mo) 200 가 , .

y) (Cu) (Si) , (Mo-allo

가 ,

6f

1

2a 2f 3a 3f 4a 4f 1 - ' - \, - \ ,

5 2f D ,

6a 6f 7a 7f 8a 8f .

9 2 .

< >

121 : 131 :

133 : 135 :

137 : 139 :

141 : 149 :

151 : 155 :

157 : - 159 :

169 : 171 :

173 :

(liquid crystal display device) , (Cu) (Mo-alloy)

1

(21) (T) (33) (T)가 (53) (matrix type) ,

(33) (33) 가 (35) , (35)

(53) (53) 가 (55) , (55)

(71) (35) (55) 가 (73) .

(33) (53) (P) .

(33) (C<sub>ST</sub>)가 .

(39) (T) (31) (49) (51) , (31)

(33) (C<sub>ST</sub>) (33) 1 ,

(69) (33) (63) - (57) (49,51) 2 .

(Al)( (31) ) (33) ( (35) ) .

가 (51) ( (53) ) (55) ,

2a 2f 3a 3f 4a 4f ,

2a 2f 3a 3f 4a 4f , 1 - ` , - ` , - ` , 3a 3f

( 2a 2f ) .

2a 3a 4a , (21) (Al) (35) (33)

(21) (31) .

(33) (signal delay) (hillock)

(Cr) (Mo)) 가 , 가 가 ( (

2b 3b 4b (SiN<sub>x</sub>) (SiO<sub>2</sub>) (33) (31) (

21) 1 (37) .

(n+a-Si:H) (31) , (39) (37) (a-Si:H) (41) .

Mo , 2c 3c 4c (41) (21) , (

(Al) (Mo) , 1,2,3 (43,45,47) .

, 2d 3d 4d , 1,2,3 (43,45,47) , /  
 / (Mo/Al/Mo) 3 (41) ( 1 53)  
 (49) (51) (55) (49) ( 1 53)  
 , (33) - (57)  
 (49,51) ( 1 53) (Mo) (Cr) 가  
 , (49,51) (53)  
 , (49,51) ( 1 53)  
 가 (spiking) 2 (39) (41)  
 , (49,51) ( 1 53) (55) (Mo/  
 Al/Mo) (49,51) (41)  
 (39)  
 2e 3e 4e (49,51) (21)  
 , 2 (59) (59) (51) (61) , - (57)  
 (59) (63) , (35) (67) (65) ,  
 (55) (59) (21) - - (ITO) (5  
 1) - - (IZO) (57) (69) , (35)  
 (71) , (55) (73)  
 , (49,51) ( 1 53) (55) (Mo)  
 가 ( ) ,  
 , 가  
 , 5 5 2f D  
 , (45) (Mo) (47,43)  
 , (49, 2f 51) ( 1 53) ( 2f 5  
 5) 가 (55) (45) (E)

(59)

(39)

(41)  
)

가 .

(

(Mo-alloy)

(Cu)

가 가

(Mo-alloy)

(Cu)

가

가

(Mo-alloy)

(Cu)

(Mo-alloy)

(Cu)

Al)

(Mo)

(Ti),

(Ta),

(Cr),

(Ni),

(Nd),

(In),

(

(Mo)

Cu)

(Mo-alloy)

(

(Cu)

-- 1 --

(Mo-alloy)

1

(Cu)

6a

6f

7a

7f

8a

8f

6a 6f 7a 7f 8a 8f ( 6  
a 6f 7a 7f 8a 8f , 7a 7f , 8a  
8f .)

6a 7a 8a , (121) (Mo-alloy) (M) (Cu) (C)  
(135), (121) (133) , (133)  
(133) (131)

, (Al) (M) (Mo) (Ti), (Ta), (Cr), (Ni), (Nd), (In),  
, (135,133) (131) (121) 200

1) , (M) (C) (C) (D)  
, (Mo)

6b 7b 8b , (C) (D1)  
(133) (131) (100) (SiN<sub>x</sub>) (SiO<sub>2</sub>)  
(137) (137)

, (131) (137) (139)(active layer)  
(141)(ohmic contact layer)

(139) (a-Si:H) , (141)  
(n+a-Si:H)

, 6c 7c 8c , (141) (121)  
(143) (145)

(143) (145)

, 6d 7d 8d , (143) (145)  
(149) (151) , (149) ( )  
(155)

, (133) - (157)

, (149) (151) (141)  
(139)

, (149,151) ( ) (155) (121)  
200

, (D2)  
(Nd), (D2) , (Mo) (Ti), (Ta), (Cr), (Ni),  
(In), (Al)

(D2) (145)

, (143) (145) (141)  
(145) (141)

6e ( ) 7e ( ) 8e (121) (BCB) (Acryl) (D2) (SiN<sub>x</sub>) (resin) (149) (SiO<sub>2</sub>) (151)

(165) (157) (155) (163) (151) (167) (135) (161) -

(ITO) 6f - 7f - 8f (IZO) (159) (121) - -

(135) (151) - (157) (169) (171) (155) (161) (

173) .

1

2

1

-- 2 --

2 1 .( 1

9 2

(D) (221) (T) (P) (G) (24

1)) (249) (231) (251) (239) (T)

(233) (233) (G) (P) (235)

( ) (D) (255) .

(P) (251) (269)

(M) (233) (231) (Cu) (C)

(D1) (C) (M)

(D1) (C) (221) (C) (221)

(C) (249,251) ( ) 1 (D2) (M)

2

가

가

가 . , 가 ,  
가 .

(57)

1. , (Mo-alloy) (Cu) ;

;

;

;

1 2. , (Mo) (Ti), (Ta), (Cr), (Ni), (Nd), (In), (Al)

1 3. , (a-Si:H) , (n+a-Si:H)

1 4. , (Cu) (Mo-alloy) ,

5. ,

5 6. , (Mo)

5 7. , 1~100 .

1 8.

8 9.

9 10.

8 11.

가

1 12.

12 13.

13 14.

1 ~100

15.

(Mo-alloy)

(Cu)

(Cu)

;

16.

15

(Mo) (Ti), (Ta), (Cr), (Ni), (Nd), (In), (Al)

17.

15

16

(Mo)

18.

15

(a-Si:H)

(n+a-Si:H)

19.

15

20.

19

21.

15

22.

15

23.

15

24.

23

가

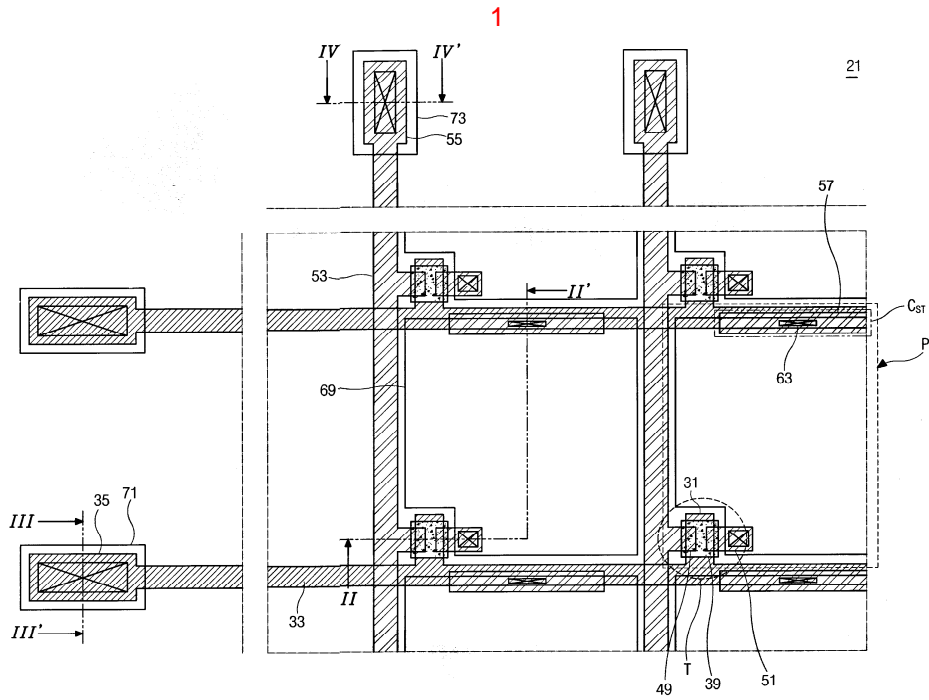

**2a**

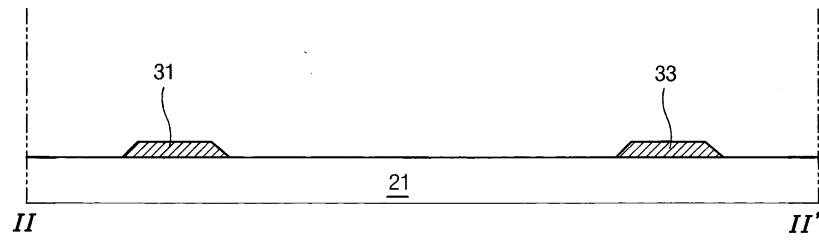

**2b**

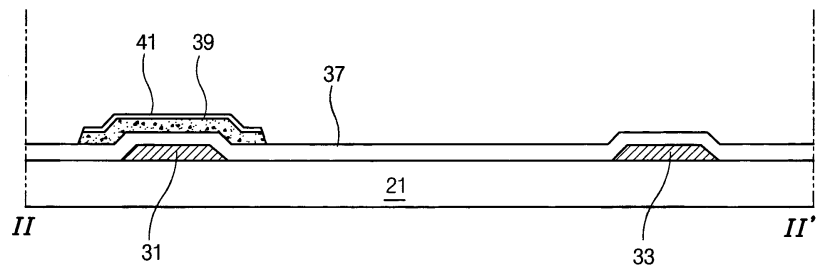

**2c**

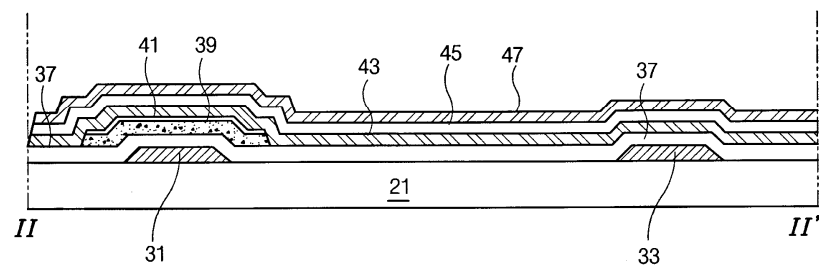

2d

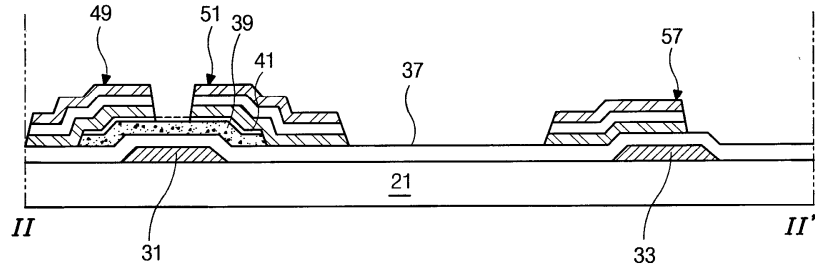

2e

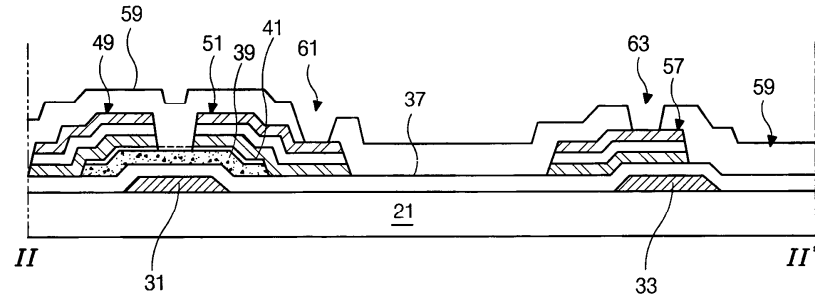

2f

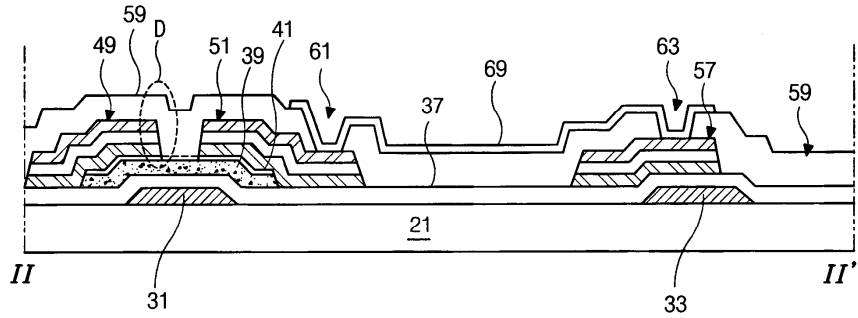

3a

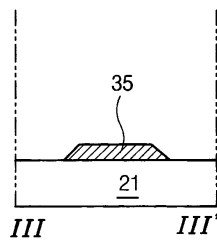

3b

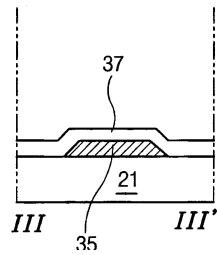

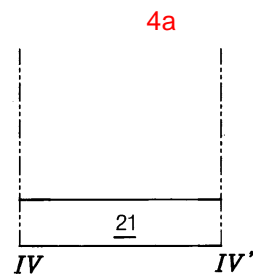
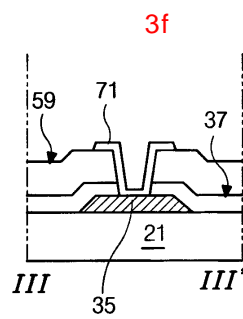
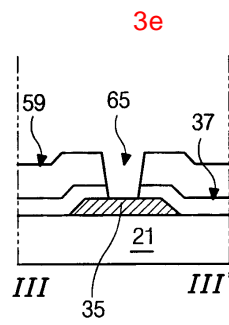
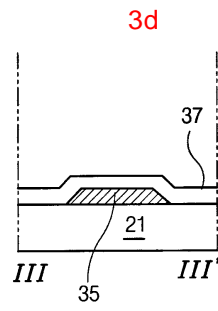
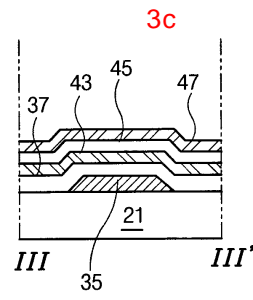

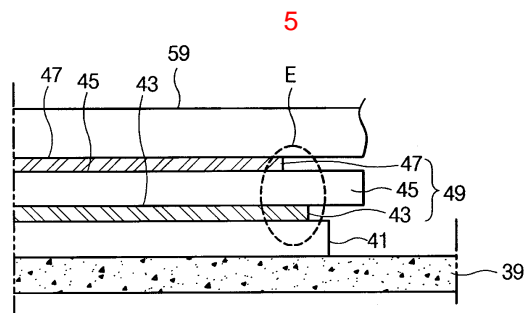
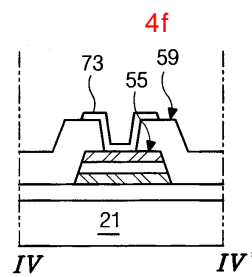
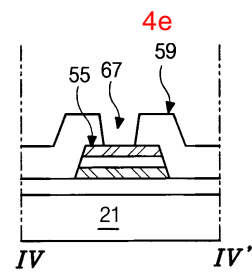
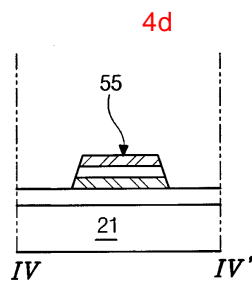
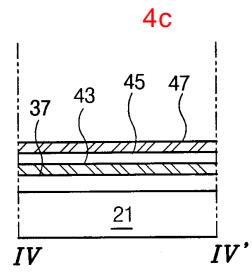
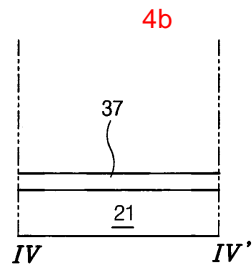

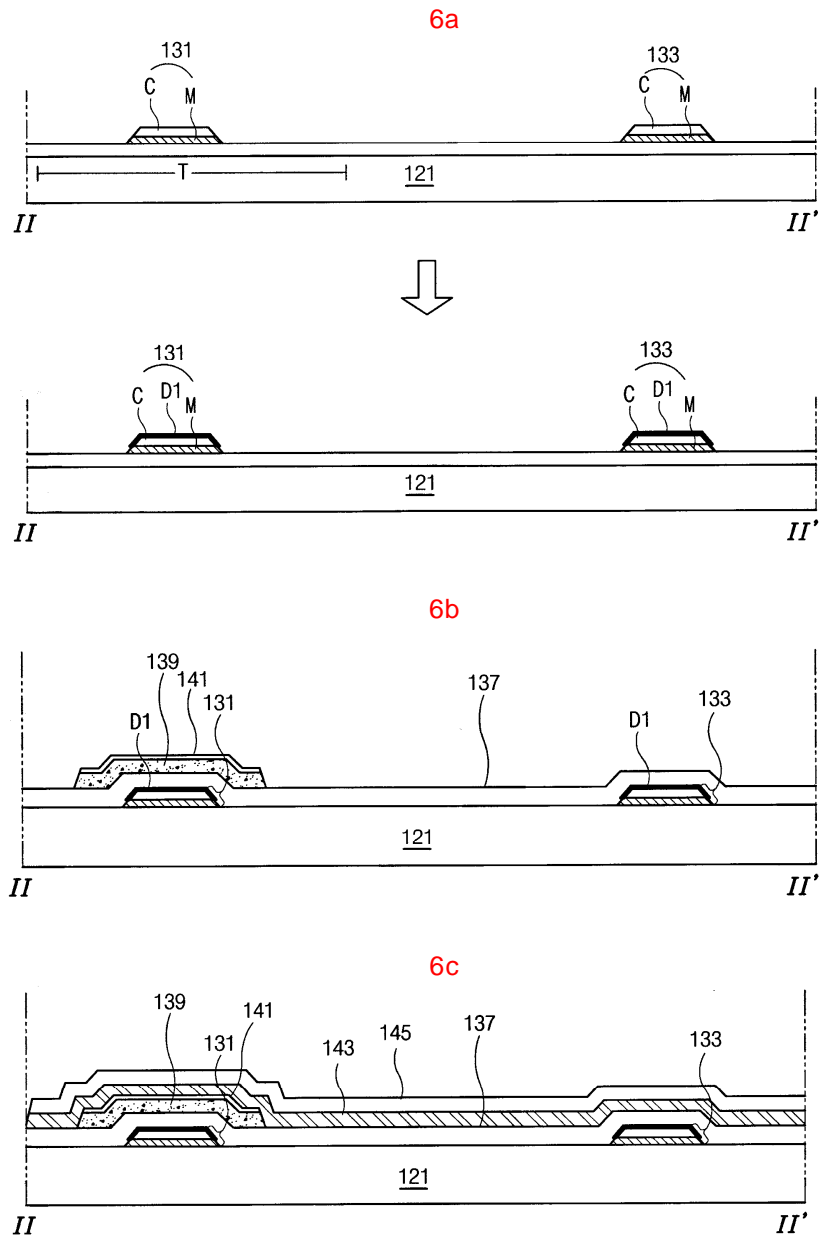

6d

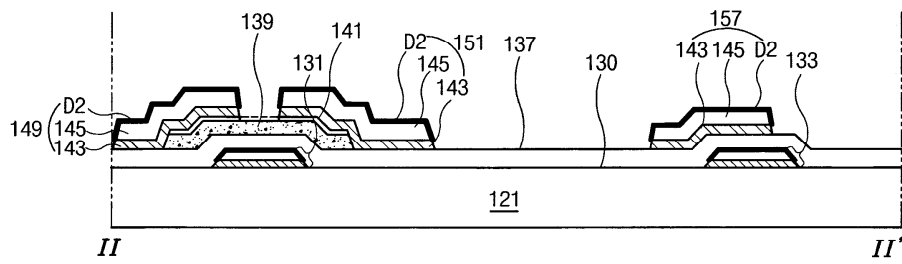
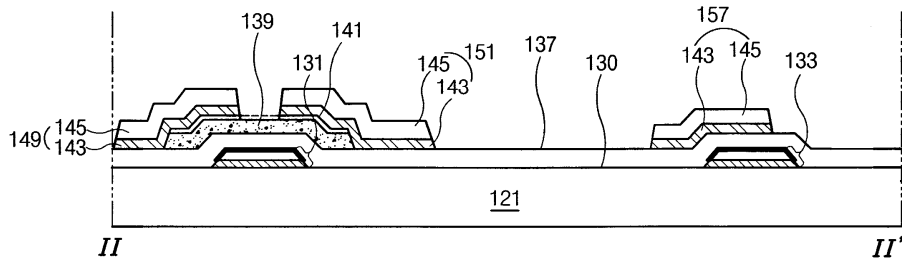

6e

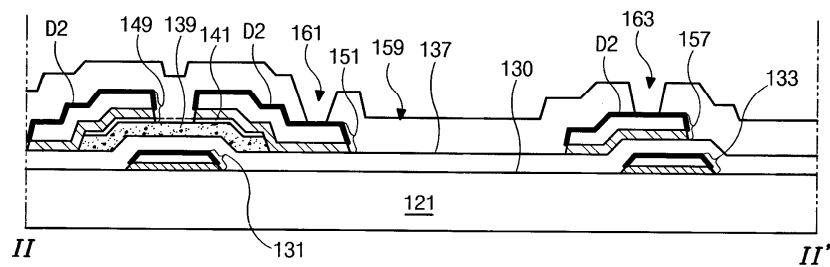

6f

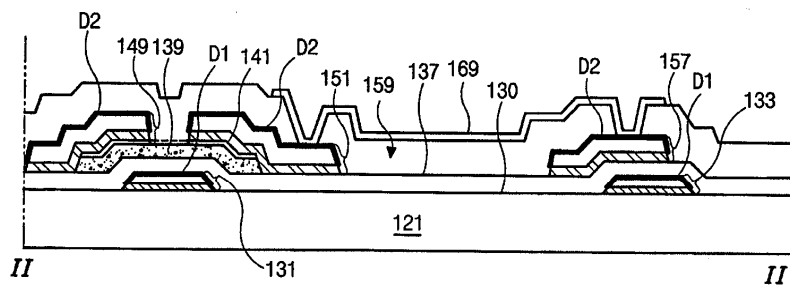

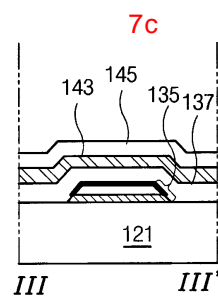
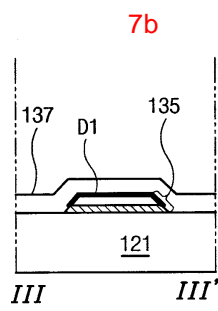
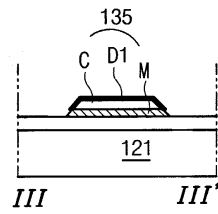
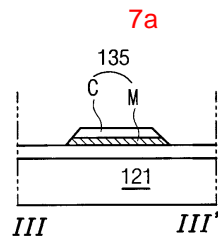

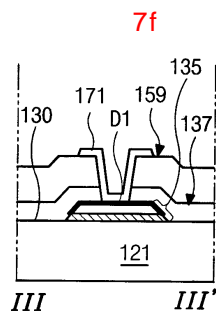
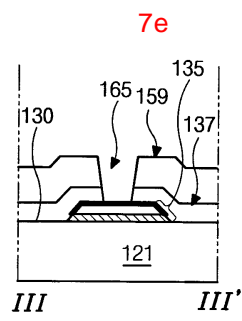
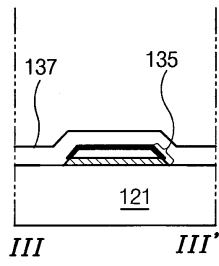
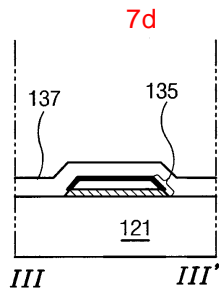

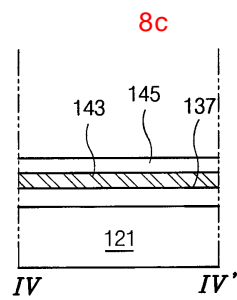
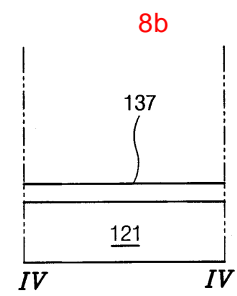
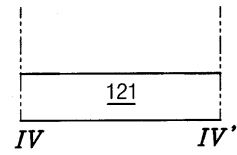
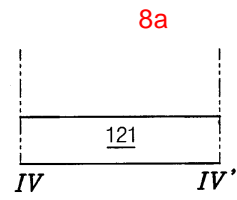

8d

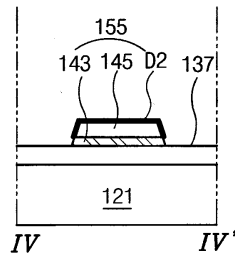
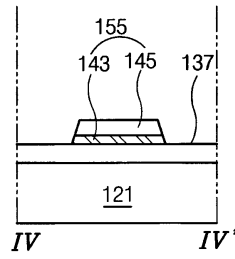

8e

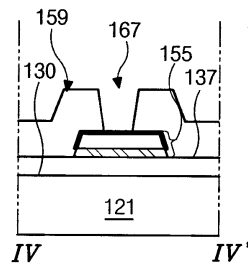

8f

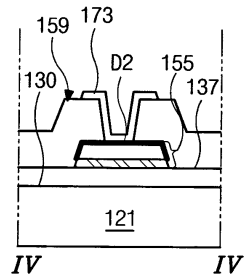

9

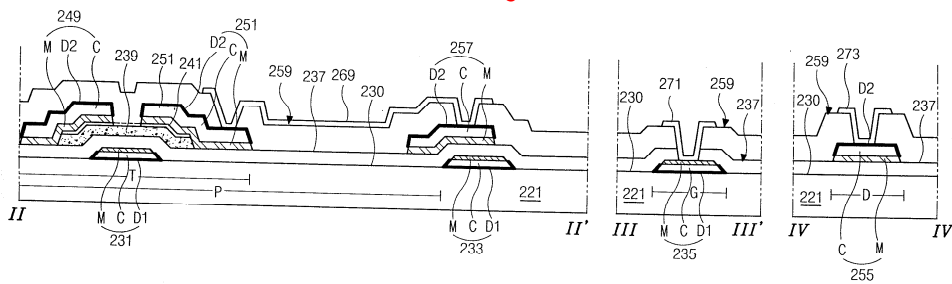

|                |   |         |            |
|----------------|---|---------|------------|
| 专利名称(译)        | 用于液晶显示装置的阵列基板和制造方法  |         |            |
| 公开(公告)号        | <a href="#">KR1020050003246A</a>  | 公开(公告)日 | 2005-01-10 |
| 申请号            | KR1020030043962   | 申请日     | 2003-06-30 |
| [标]申请(专利权)人(译) | 乐金显示有限公司  |         |            |
| 申请(专利权)人(译)    | LG显示器有限公司   |         |            |
| 当前申请(专利权)人(译)  | LG显示器有限公司   |         |            |
| [标]发明人         | CHO WONHO<br>조원호<br>JO GYOOCHUL<br>조규철<br>LEE GUETAI<br>이규태<br>KANG JINGYU<br>강진규<br>JEONG BEUNGHWA<br>정병화<br>KIM JINYOUNG<br>김진영 |         |            |
| 发明人            | 조원호<br>조규철<br>이규태<br>강진규<br>정병화<br>김진영  |         |            |
| IPC分类号         | G02F1/1362 G02F1/136 G02F1/1368   |         |            |
| CPC分类号         | G02F1/136286 G02F1/1368   |         |            |
| 其他公开文献         | KR100938885B1   |         |            |
| 外部链接           | <a href="#">Espacenet</a>   |         |            |

摘要(译)

液晶显示器的阵列基板及其制造方法技术领域本发明涉及液晶显示器，更具体地，涉及用于液晶显示器的阵列基板及其制造方法。本发明的特征在于，作为在阵列基板上形成的第一层的栅极布线和栅极电极由双层铜层和钼合金层构成，并且源电极和漏电极由双层形成，其中Mo合金层和Cu层依次堆叠。当对层压结构施加200°C或更高的热量时，与钼(Mo)合金化的金属从钼合金层扩散到铜层的表面。铜层周围的扩散层与绝缘膜具有良好的接触性能，以改善铜的粘附性能，并且Mo合金层用作铜层和半导体层之间的缓冲层，(Si)组分反应。因此，具有低电阻的铜可以用作布线材料，这有利于制造大面积液晶面板。图6F

