

(19)
(12)

(KR)
(A)

(51) 。 Int. Cl. ⁷
G02F 1/136

(11)
(43)

2001 - 0082837
2001 08 31

(21) 10 - 2000 - 0008313
(22) 2000 02 21

(71) .
,
20

(72) 21 103 - 1410
301 1601

(74)
:

(54)

AI

가

2

1a 1e

2

3a 3e

< >

10, 32 : 12, 34 :

14, 36 : 16, 38 :

18, 40 : 20, 42 :

22, 44 : 24, 46 :

26, 48 : 28, 52 :

30, 54 : 50 :

(Liquid Crystal Display; LCD) 가 (Active Matrix) (Thin Film Transistor; TFT)가

1a 1d

1a (14) (10) (12) (14)가 (12)
16) 1b (16) (18) (20) (18)
(20) (22, 24) (16) 1c (22)
(24) (20) (18) 가 (24)
1d (14) (26)

, (40) (42) (38) Al
 3c (44, 46)
 . , (44) (46) (42) (40)
 . 가 3d (48)
 (46) 1 (47) (36) 2
 (49) . , 1 (47) (46) 2 (49)
 (36) (50) (50)
 Mo, Ni, Cr, Cu, Ag, Pb
 3e (46) (
 52) (46) (54)

, Al
 . , 가 .
 가

(57)

1.

가 , 가 , , ,

2.

1 ,

3.

1 ,

Mo, Ni, Cr, Cu, Ag, Pb

4.

5.

4

6.

4

7.

6

Mo, Ni, Cr, Cu, Ag, Pb

1a

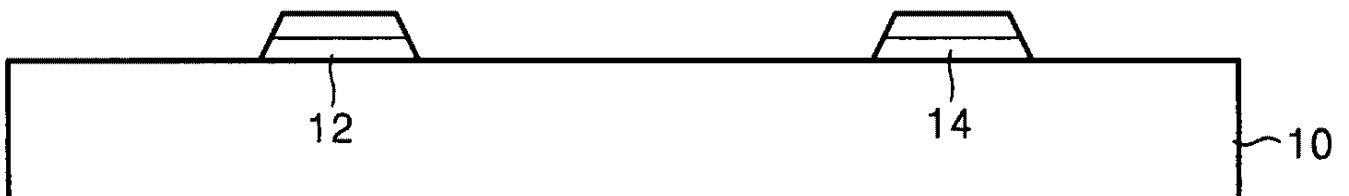

1b

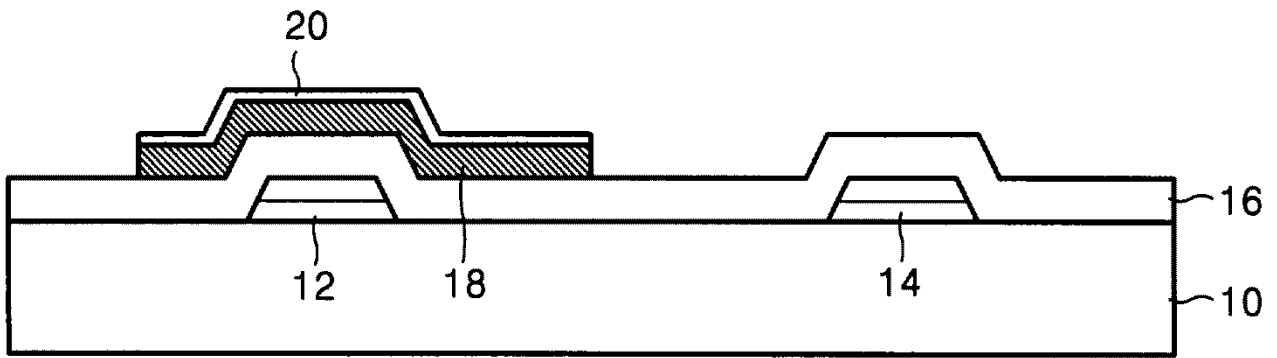

1c

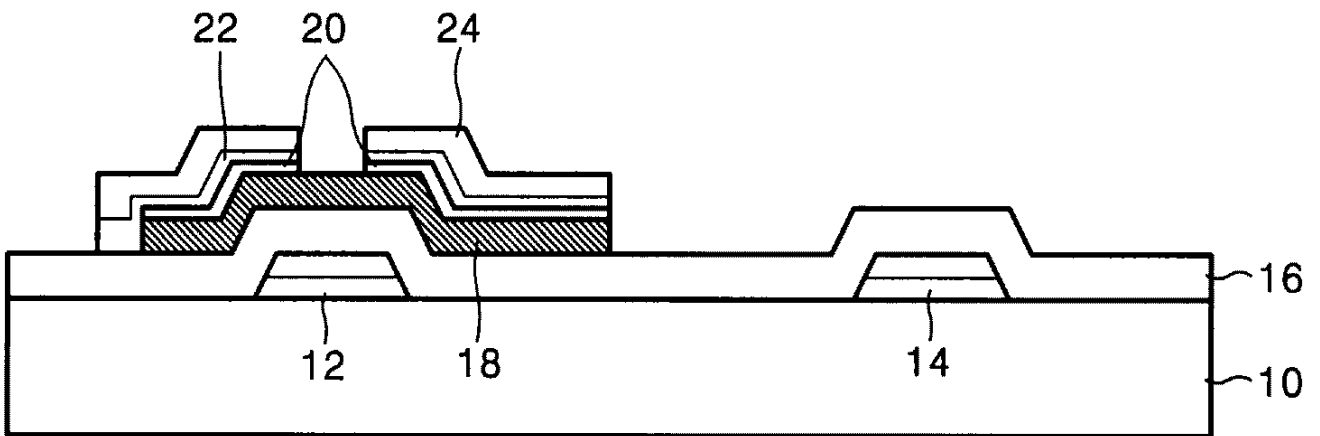

1d

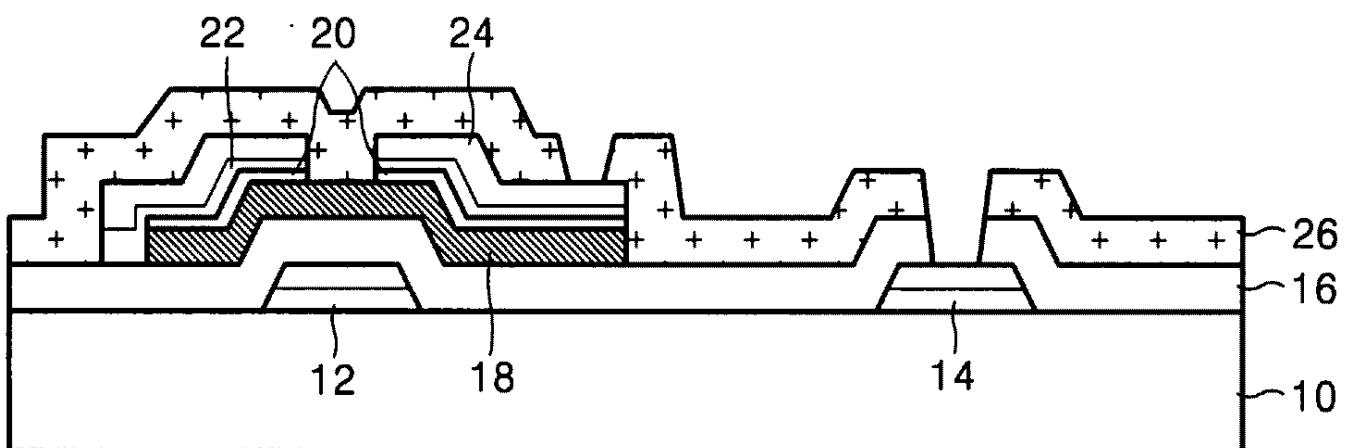

1e

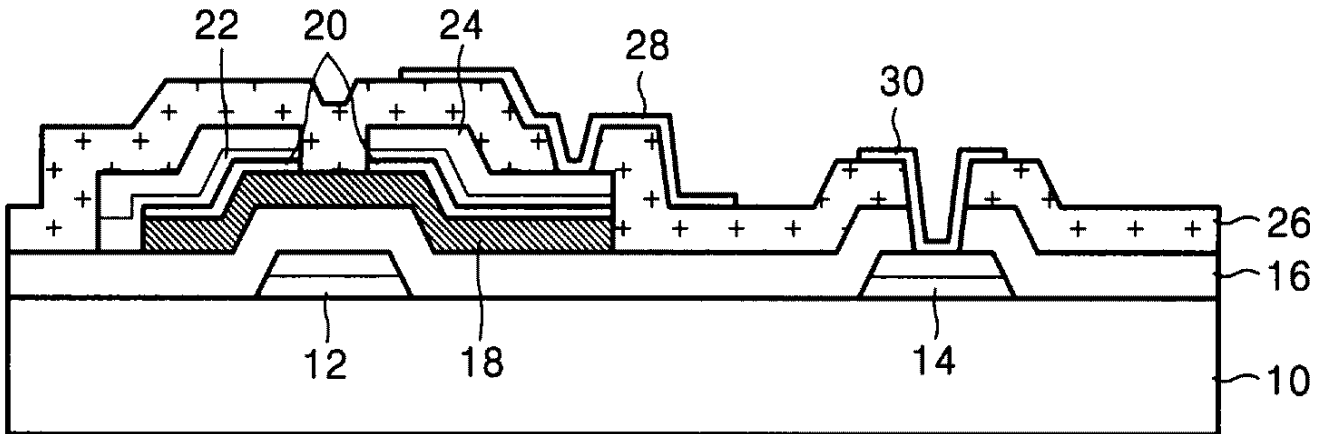

2

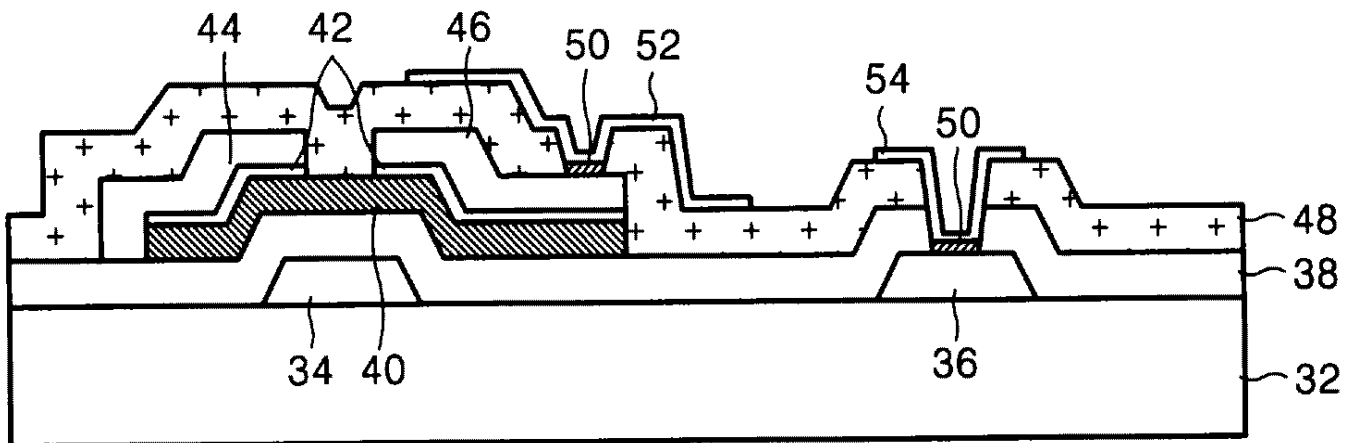

3a

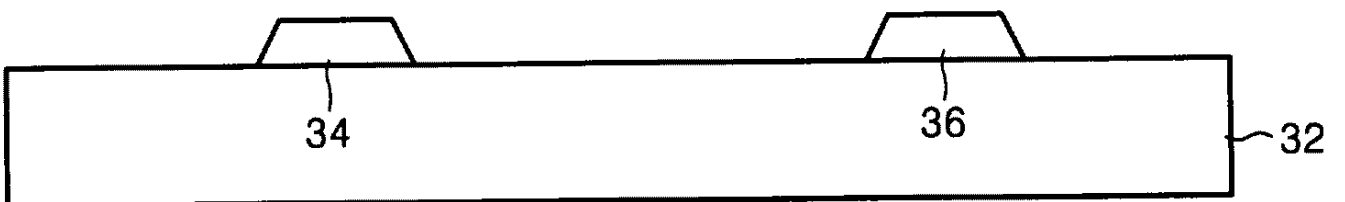

3b

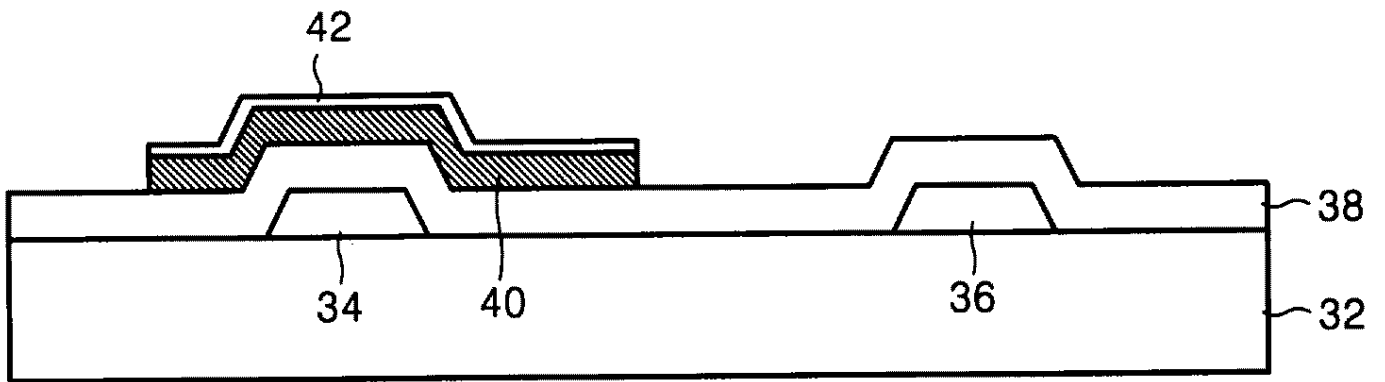

3c

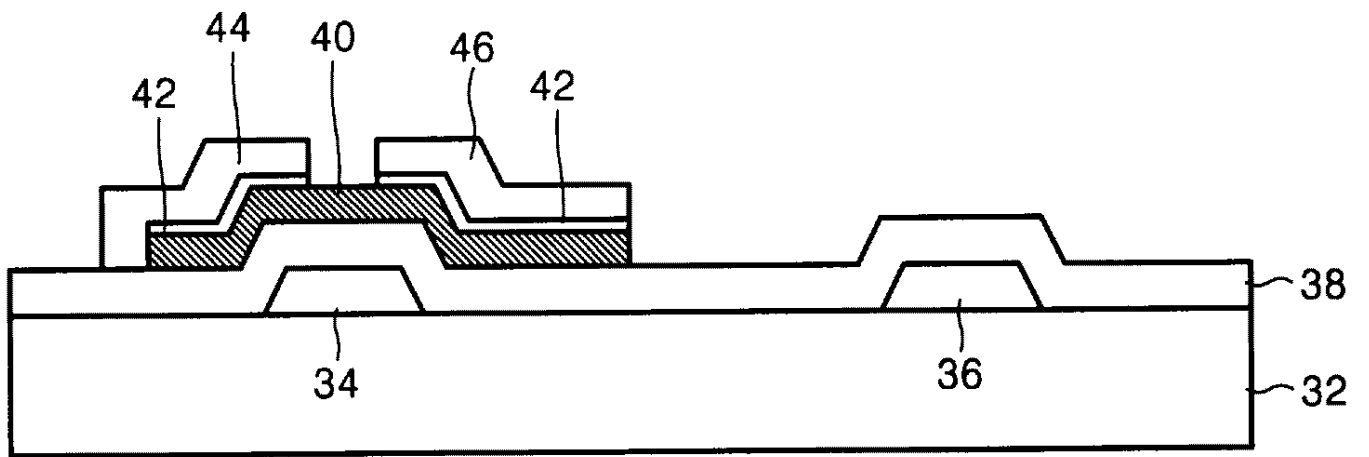

3d

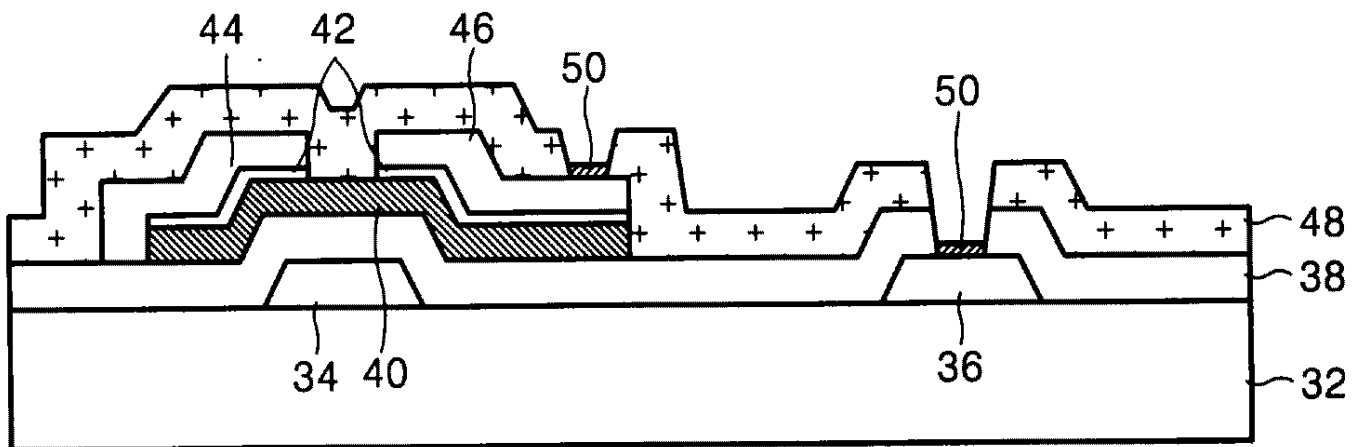

3e

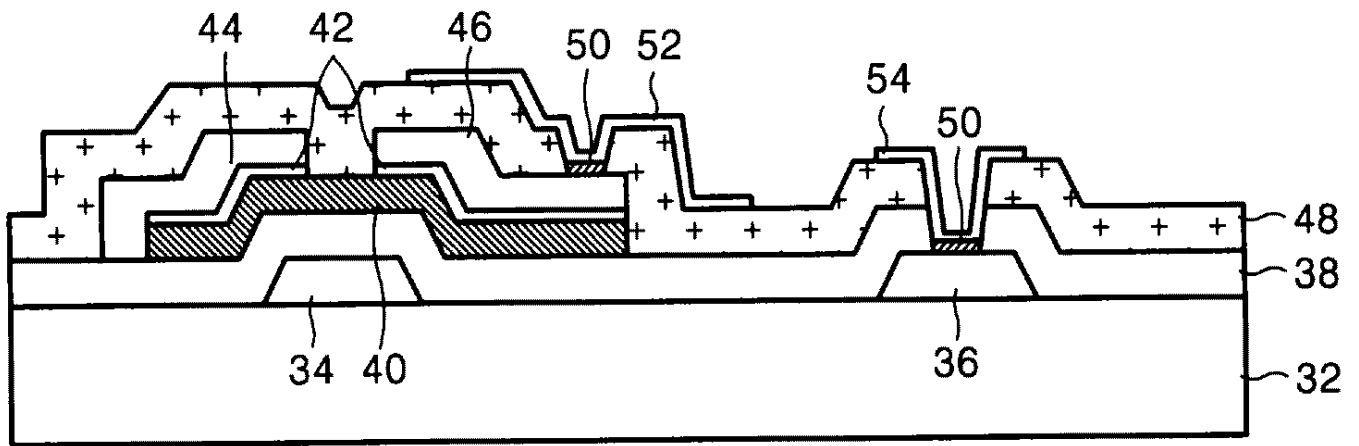

专利名称(译)	液晶显示元件及其制造方法		
公开(公告)号	KR1020010082837A	公开(公告)日	2001-08-31
申请号	KR1020000008313	申请日	2000-02-21
[标]申请(专利权)人(译)	乐金显示有限公司		
申请(专利权)人(译)	LG显示器有限公司		
当前申请(专利权)人(译)	LG显示器有限公司		
[标]发明人	KWON OHNAM 권오남 HWANG KWANGJO 황광조		
发明人	권오남 황광조		
IPC分类号	G02F1/13 G02F1/1368 G02F1/1362 G02F G02F1/136		
CPC分类号	G02F1/1368 G02F1/136227		
代理人(译)	KIM , YOUNG HO		
其他公开文献	KR100690001B1		
外部链接	Espacenet		

摘要(译)

用途：提供LCD及其制造方法，以降低单个金属电极层和透明电极之间的接触电阻。

