

(19)
(12)

(KR)
(A)

(51) 。 Int. Cl.7
G02F 1/136

(11)
(43)

10-2004-0041491
2004 05 17

(21) 10-2003-0065240
(22) 2003 09 19

(30) 1020020069578 2002 11 11 (KR)

(71) .
20

(72) LG 103 807

408-9 1 101

APT 915 1402

(74)
:

(54)

3

, 2 () 1
, 3

3

가

6

1 ,
 2 ,
 3a 3g 4a 4g 5a 5g 2 - ` , - ` , - `
 ,
 6 ,
 7a 7h 8a 8h 9a 9h 6 - ` , - ` , - `
 ,
 10 11 12 6 - ` , - ` , - `
 .

< >

100 : 102 :
 104 : 106 :
 134 : 2 136 :
 138 : 140 :
 142 : 160 :
 162 : 164 :
 166 :

1 ,
 (8) (11) (6) (7) (8) ,
 (56) (9) (5) (22) (P) (5)
 (22) (15) (T) .
 (22) , (T)가 (matrix type)
 , 가 (12) (34) .
 (P) (56) - - (12) (34) (P)
 (indium-tin-oxide : ITO)
 (T) (56)

(12) (T) 1
(34) (T) 2

가

(15) (Spontaneous Polarization) 가
(Bipolar) 가

가

가

5~7 4

2 4

(34) (12) (34) (T)가 (P) (12)

(36) (12) (10) (34)

(10,36) (58) (60)

(34) (T) 가 (12) (40) 가 (14) (42)

(14) (40) (42) (32)

(56) (P) (12) (42) (56)

(12) (12) (56) (38) (38)

(28) 2 (12) 1 (17)
(C)가 1 2

(30) (40,42) ()

(34) (36) 1 (35) (28)
(29)

4 4

4 3a 3g 4a 4g 5a 5g 2 - ` , - ` , - ` .(3a 3g 5a 5g .)

, 4a 4g , 5a 5g .)

, 3a 4a 5a (10) , (22) 1 (12) 1

, (14) .

(Al), (Al) , (Mo), (W), (Cr) (Mo) (Cr)

(12) (18) , (10) (20) , (22) 2 (24) 1 (16) ,

, 1 (16) , 2 (SiN_x) (24) (Cr), (SiO₂) (Mo), (W), (Ta)

(22) (D) (P) (T) , (S)

, (T) (P)

, 3b 4b 5b (photo-resist: 'PR') (D,T,P,S) 2 (24) PR (26) , PR (26)

(positive type)

PR (26) (22) (A) (B) () (C)

(50)

(C) (D) (T) (S) (14) , (B)

, (C) PR (26) (A)

, (50) (exposure) , (devel

op)

, 3c 4d 5d , (T) (S)

(D) PR (26)

(20) PR (26) 2 (24)

, (T) (18) / (28) , 3d 4d 5d (D) / (28)

(34) , (36)

, (12) (38)

(34) 2 (29) (36) 1 (35) , (38)

, (30) (T) 1 (32) (30) ,

, 3e 4e 5e PR (T) (CH) (ashing processing)

PR (26) (F) 가 (14) (28,34(),38,36(PR)) , .
 , PR (26) .
 , PR (26) 가 (Mo) , (Cr) PR
 , 3f 4f 5f (40) , (42) (T) / (30)
 (CH) .
 (36) 2 (12) , (32) (38) (40,42) (34)
 , (22) (40,42) (34) (36) (38)
 (BCB) (acryl) (resin)
 (SiN_x) (SiO₂)
 2 (46) .
 , (46) 3 , (42)
 (48) , (38) (50) , (10)
 (36) (52) (54) .
 , 3g 4g 5g , (46) - - (ITO) - -
 (IZO) (42) (P) 4 (38) , (56) ,
 (60) (10) (58) (36)

4

(halftone)

3

가

1

2

1

2

3

3

2

1

2

3

1

2

3

6

(112), (100) (102) (132) (P),
 (132) (T)

(102) (106) (132)
 (142) (106,142)

(164) (166)

(T) (102) 가 (104), (138)
 (132) 가 (136) 가

(P) (138) (162) (P)
 (102) (134)

(138) (102) (C) (102) 1
 (134) (162) 2

(136,138) 2 (134) (132)
 (142)

132) (136,138) 1 (126) 1 (126) (
 (142) 2 (130) 2 (134)

3 (128)

1 (126) 2 (130) 3 (128) (136,138)
 (132) (142) 2 (134) .(

(166) (100) (162) (164)
 (162)

) 3 (162) (164) (166)

7a 7h 8a 8h 9a 9h

7a 7h 8a 8h 9a 9h 6 - ` , - ` , - ` ,

(7a 7h 8a 8h
 , 9a 9h) , 8a 8h

7a 8a 9a (100) (Al), (W), (Mo), (Cr)
 (104) 1 (102) (106)

(104) RC (delay)

(hillock)
 가

7b 8b 9b (102) (104)
 (106) (100) (SiO₂), (SiN_x)

(BCB) (Acryl) (resin) , (108)

H)(112) , 2 (114) (108) (a-Si:H)(110) (n+a-Si:

, 2 (photo-resist : PR) PR (116)

2 (114) (Cr), (Mo), (W), (Ta)

, PR (116) (100) (P) (T) (D)
(S)

, (P) (T)

, (100) (A) (C) (B) (M)

, (M) (B) (D) (S) , (T)
, (C) (T) (104)

(M) , (100) PR (116)

7b C) 7c 8c 9c , 가 PR (T) (M) (D)
(S) PR PR (120a) (120b)

, PR (120a,120b) , PR 2 (114) (112)
sing) (110) , PR (ashing proces

(124) , 7d 8d 9d (124) (F) (E) (T) PR / (122a)

, (124) (S) (134) (D) /
(142) (132) (132,142) (132) ,
PR (122b) (134) (F)

, PR (122a,122b)
PR (122a,122b)

(102) , 7e 8e 9e (136) (138) , (136) (T) (D) (142)
(132) , (102) 2 (134)

(142) (136,138) 2 (130) , 1 (126) , 1 (132)
(134) 2 (134) 3 (128)

(126b,130b,128b) (126a,130a,128a)

(132) (142) (136,138) , 2 (134)
 (130a,126a,128a)

146) (100) (136,138) (132) (142) 2 ()
 (BCB) (acryl) (resin)가 (160)

3 (160) 7f 8f 9f ,
 (T) (142) (132) , (106)
 (102) 2 (146) (142)
 (106) () (160)

(160) (curing) (160)
 ()

(160) 90

7g 8g 9g (160) (108)
 (106)

7h 8h 9h (160) (100)
 (ITO) - - (IZO) -
 (138) 2 (146) (P) (162) ,
 (106) (164) , (142)
 (166)

(160) (100)

가 3

) (T) (T) (126a) (160) (160) , (160)

10 11 12

10 11 12 6 - , - , -

(143) (T) (160) (160) (143)

(SiN_x) (SiO₂) (T) (136,138) (132)

(160) (160)

(160) (100) - - (ITO) - - (IZO)
 (138) 2 (146)

(P) (164) , (162) , (106) (166) .
 (143) , (T) (132) (102) (160) (T) (12)
 6a) (143) , (143) (T) .
 0) , (143) (102,132) (16)

3 가 , 가

(57)

1.

, ;
 ;
 ;
 가 , ;
 , ;
 , ;

2.

1 , .

3.

2 , .

4.

1 , .

5.

1 4 ,

1 **6.** 5 ,

, 1 2

1 **7.** ,

1 **8.**

1 ; , 2 ; ,

3 ; , 3 ;

8 **9.** ,

2 ; , ;

1 , 2 ; ;

9 10.

3

8 11.

8 12.

8 13. 12

8 14. 13

1

2

8 15.

15 16.

1

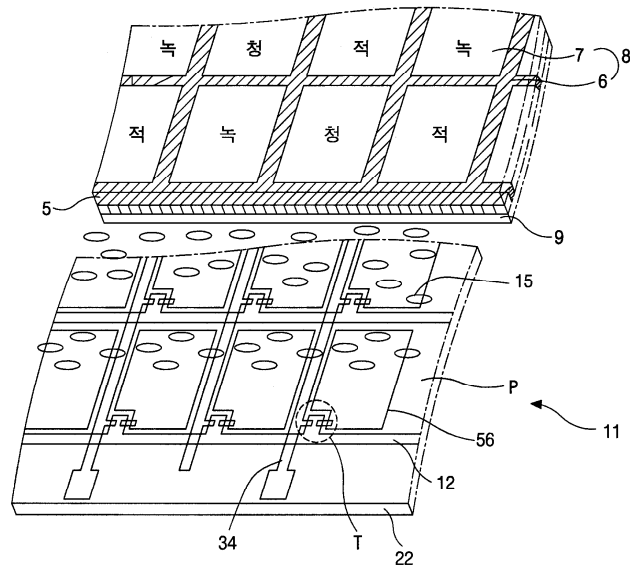

2

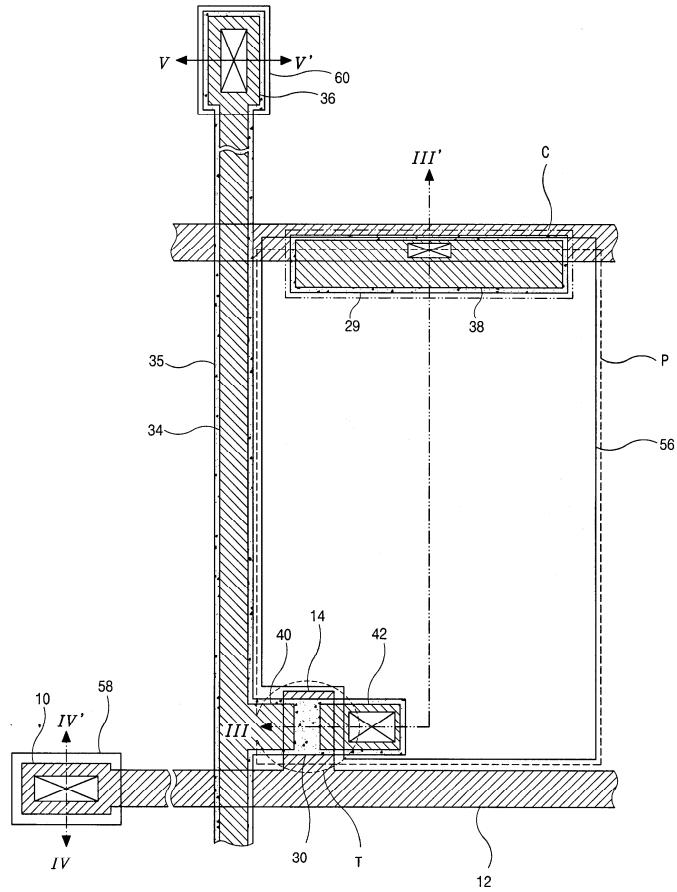

3a

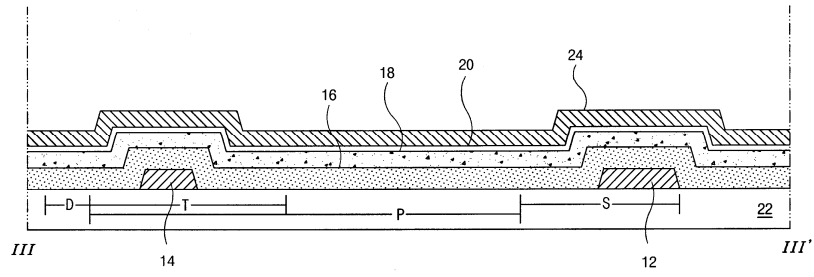

3b

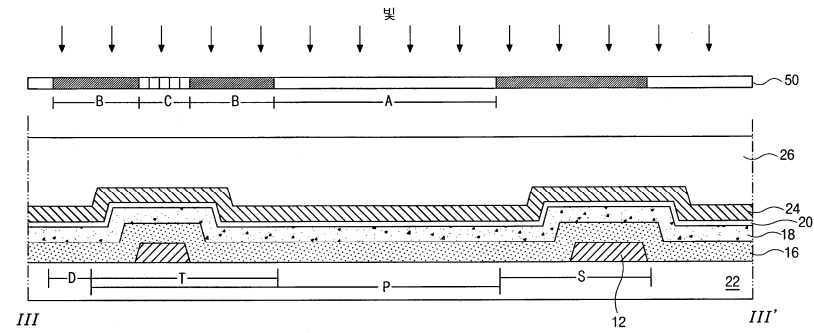

3c

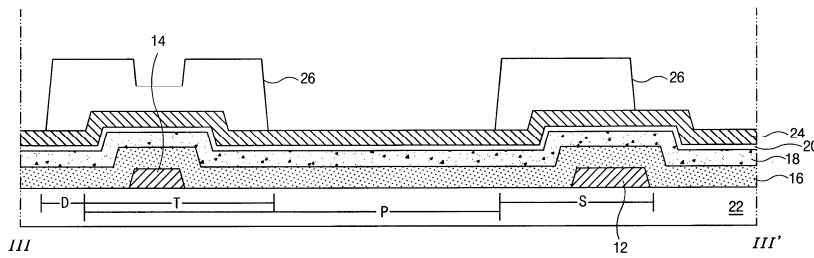

3d

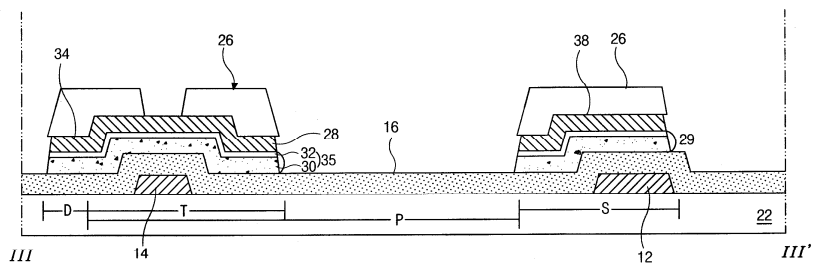

3e

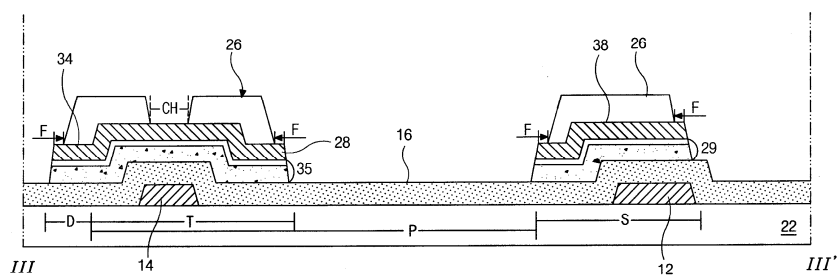

3f

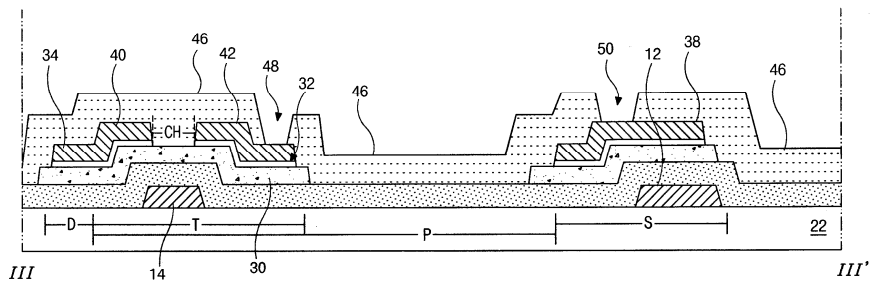

3g

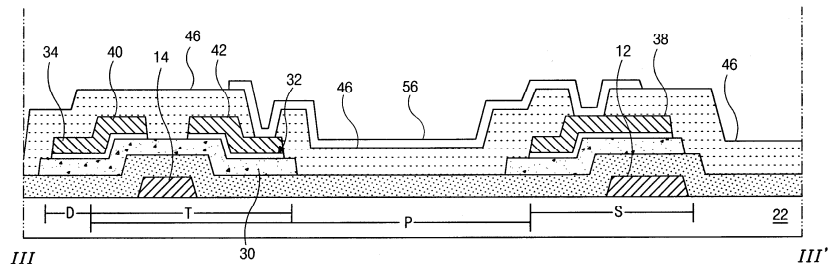

4a

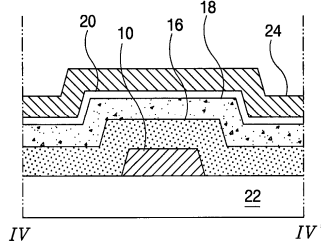

4b

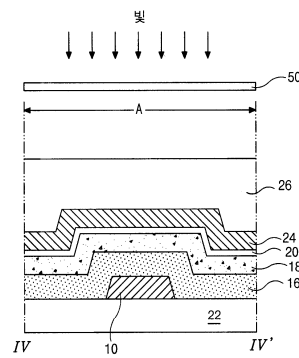

4c

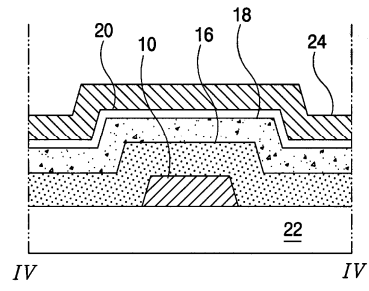

4d

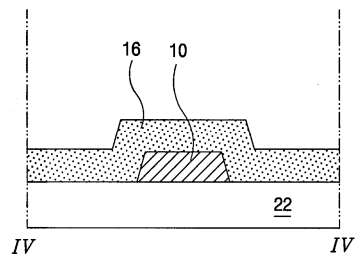

4e

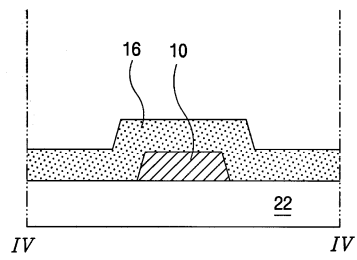

4f

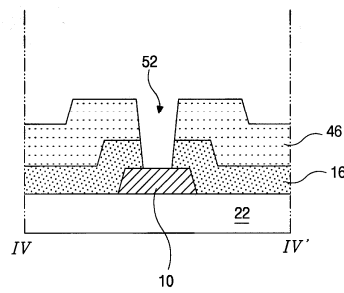

4g

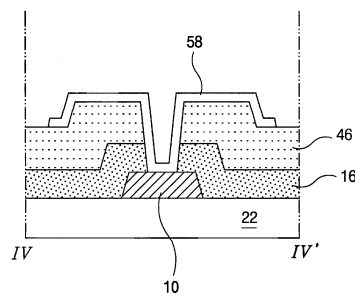

5a

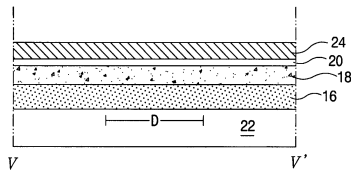

5b

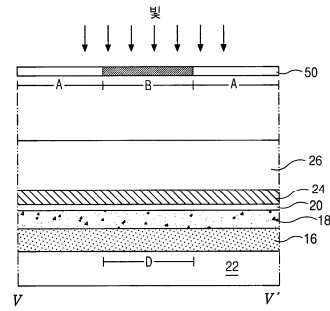

5c

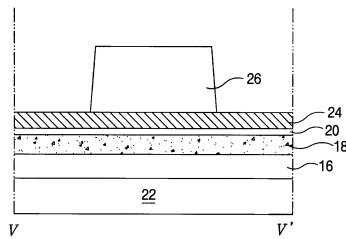

5d

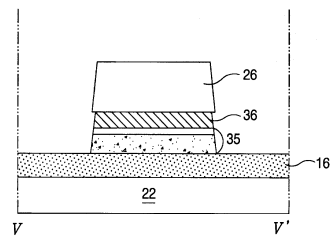

5e

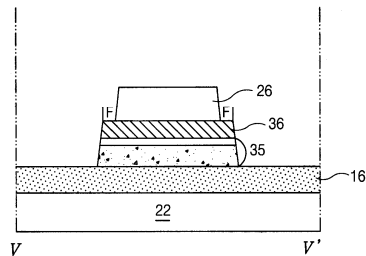

5f

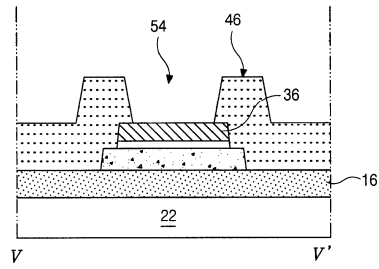

5g

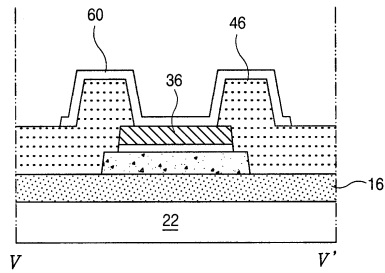

6

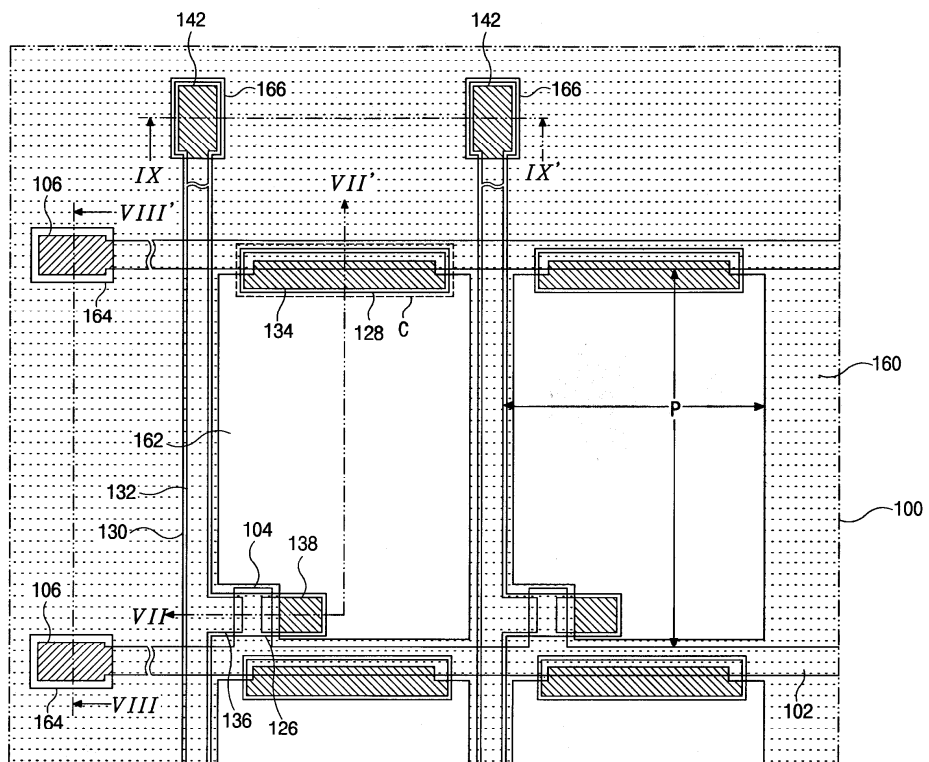

7a

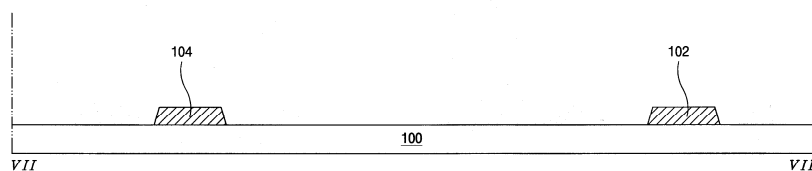

7b

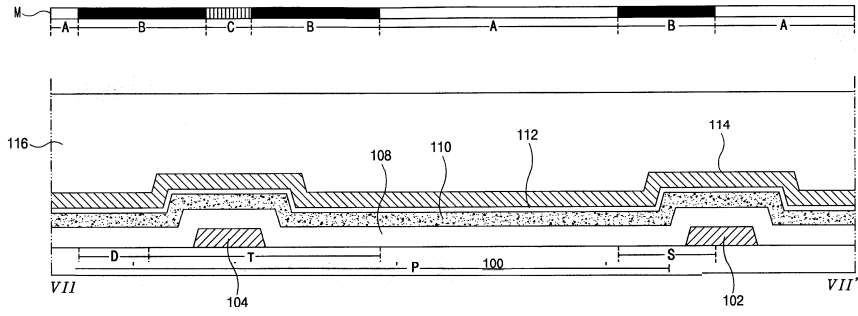

7c

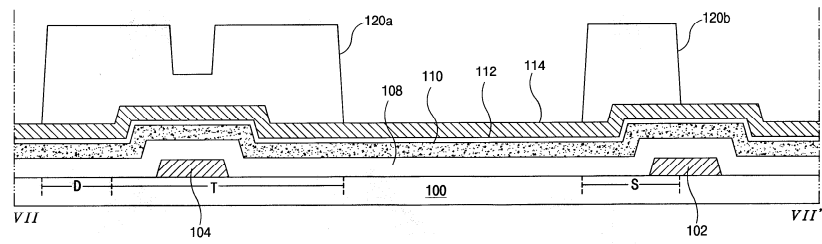

7d

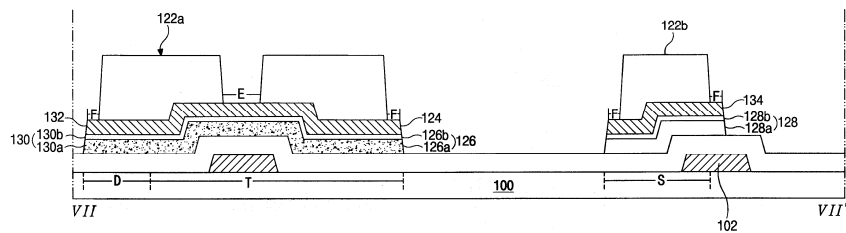

7e

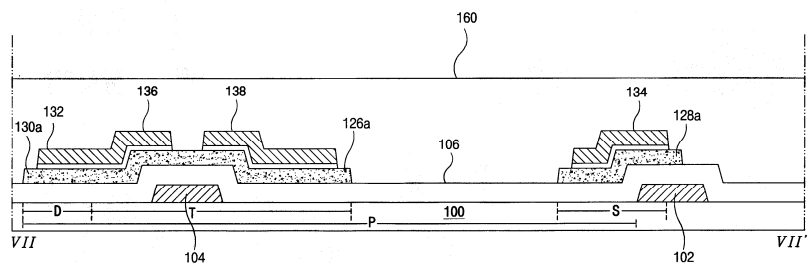

7f

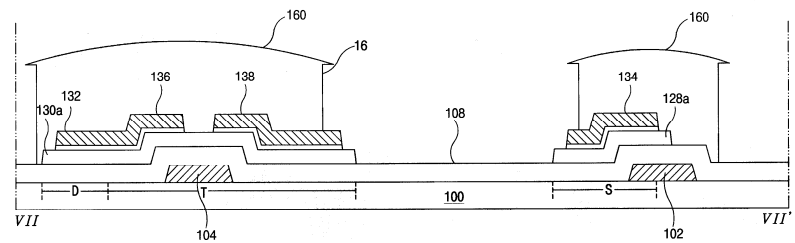

7g

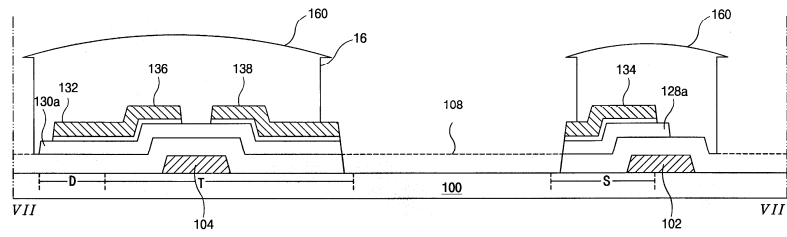

7h

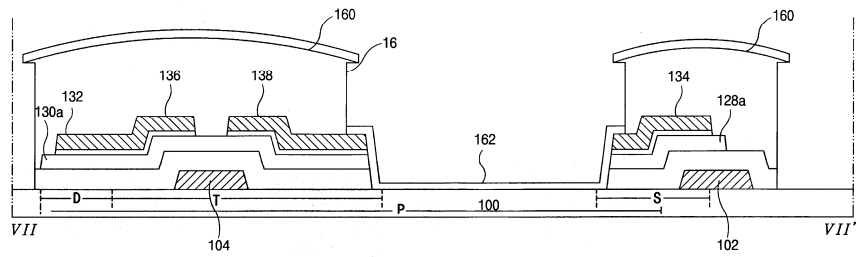

8a

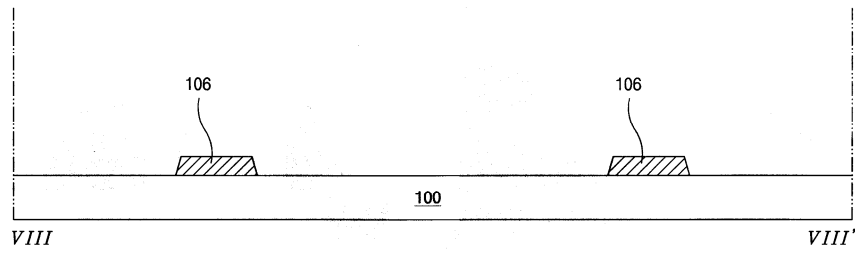

8b

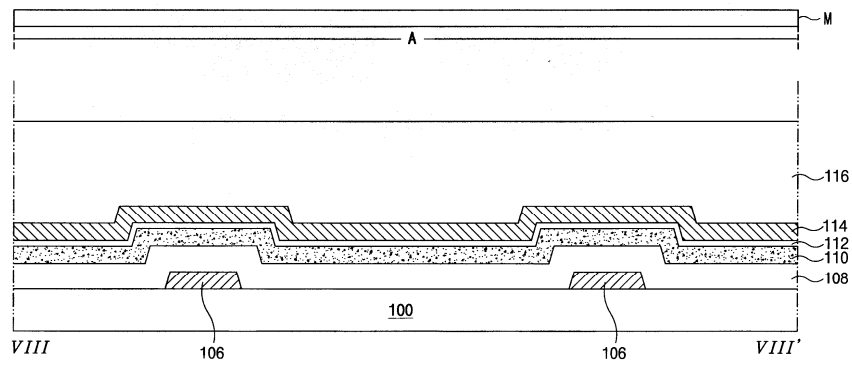

8c

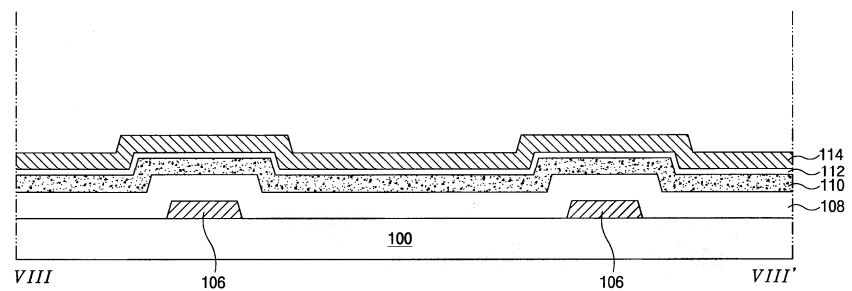

8d

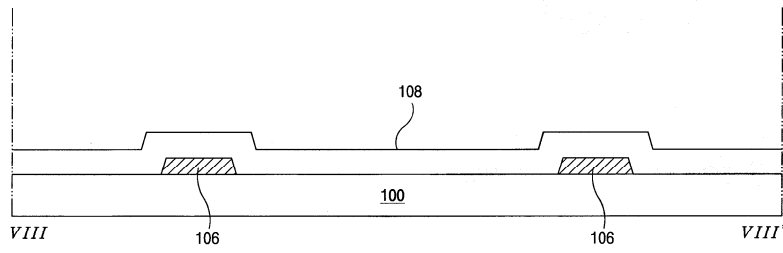

8e

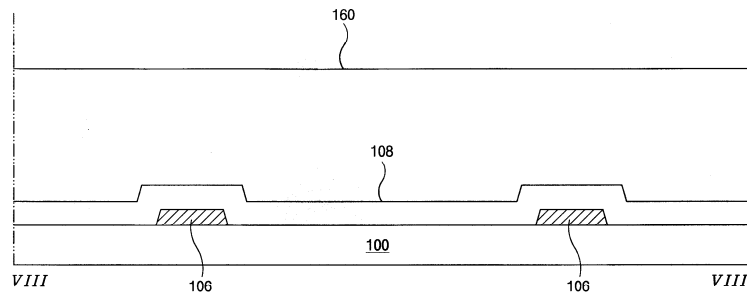

8f

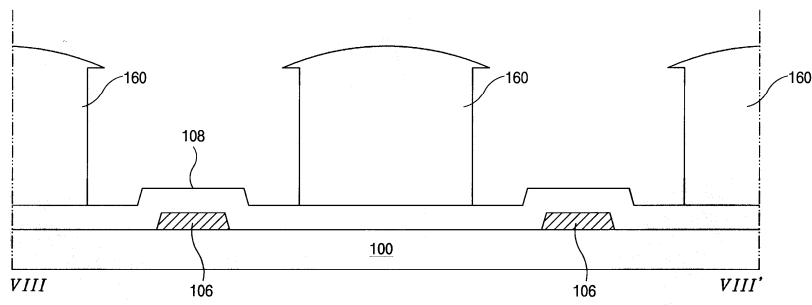

8g

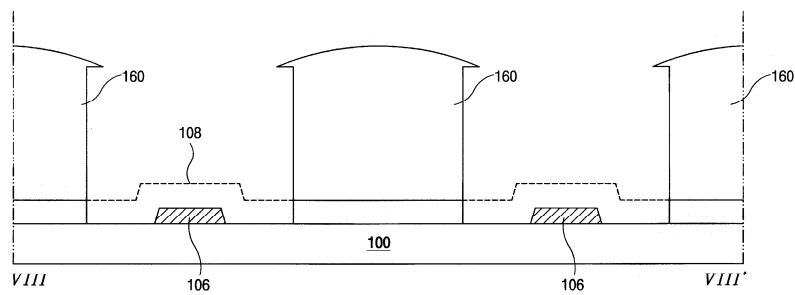

8h

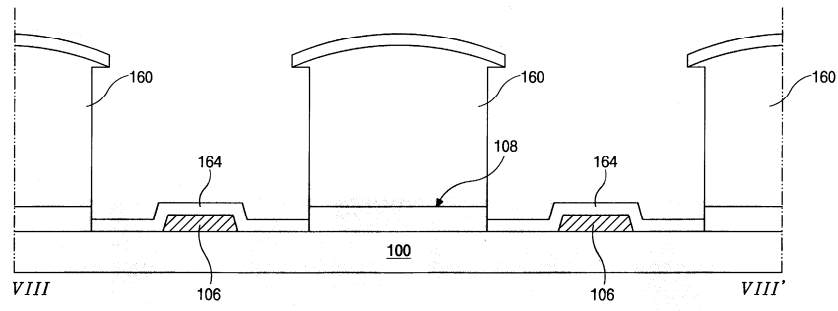

9a

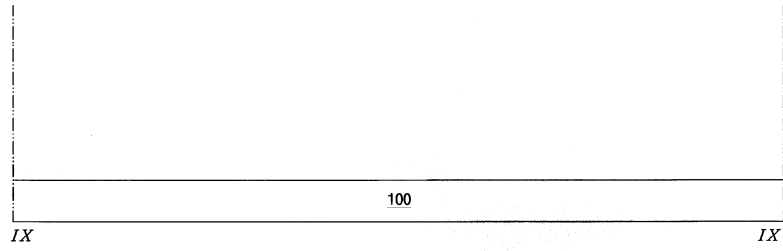

9b

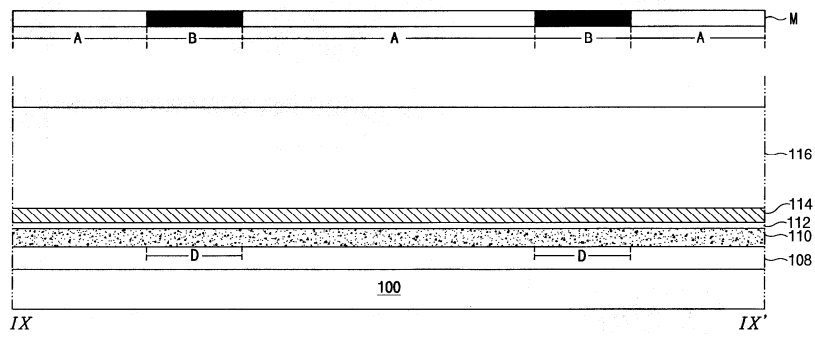

9c

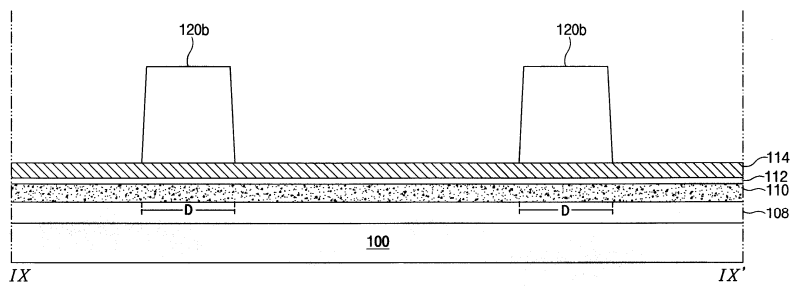

9d

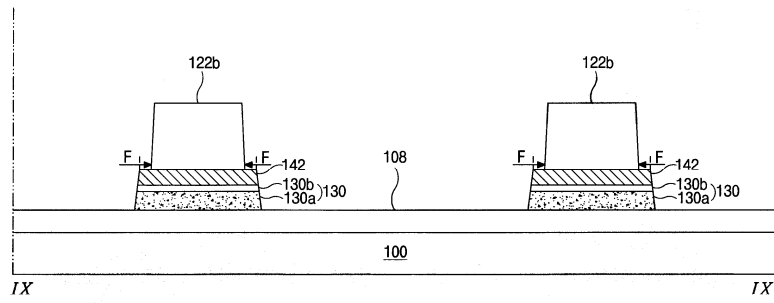

9e

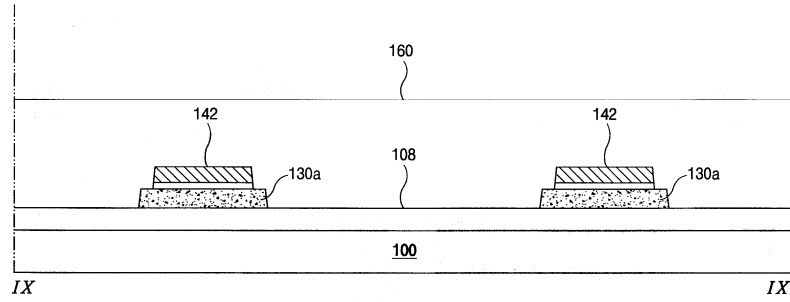

9f

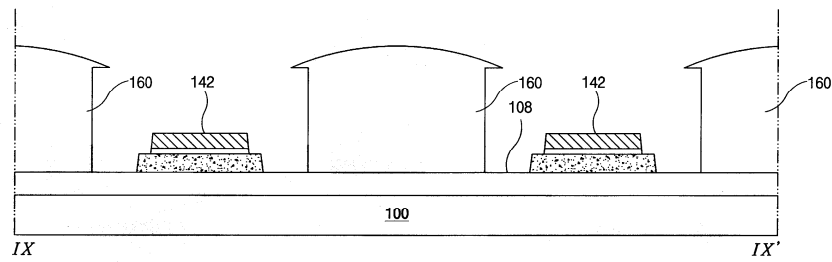

9g

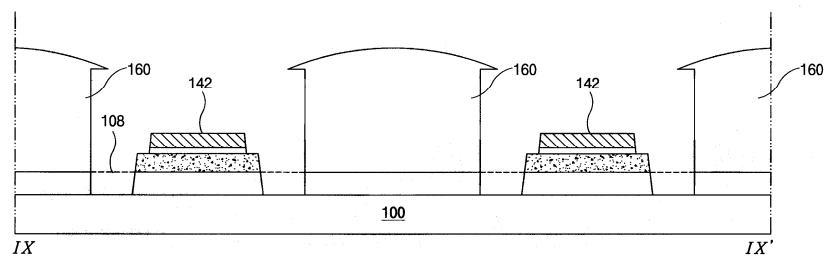

9h

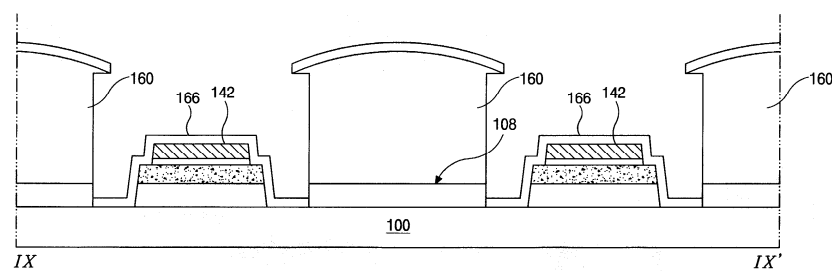

10

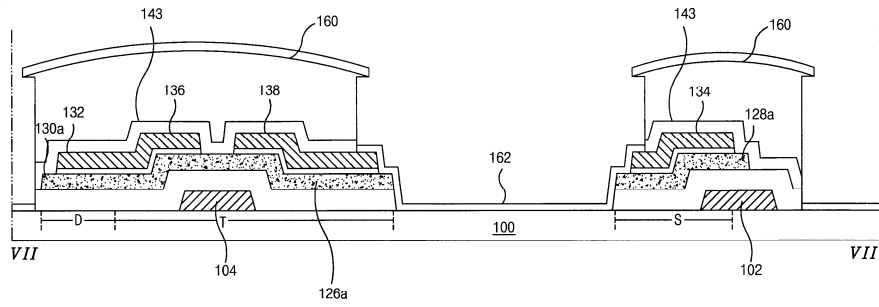

11

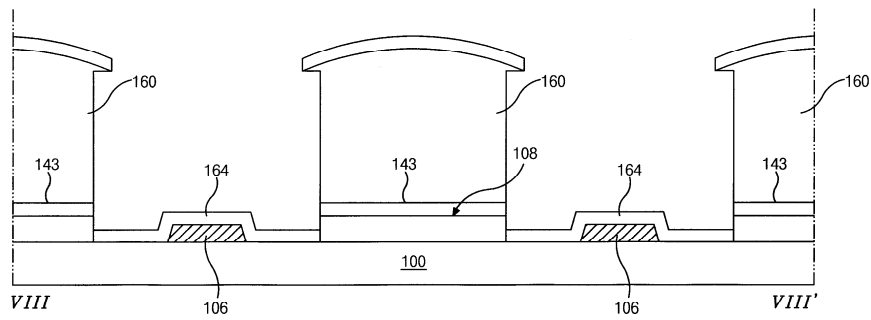

12

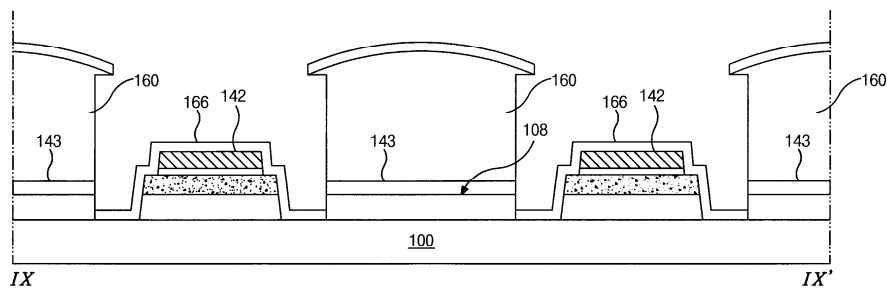

专利名称(译)	制造用于液晶显示器的阵列基板的方法		
公开(公告)号	KR1020040041491A	公开(公告)日	2004-05-17
申请号	KR1020030065240	申请日	2003-09-19
[标]申请(专利权)人(译)	乐金显示有限公司		
申请(专利权)人(译)	LG显示器有限公司		
当前申请(专利权)人(译)	LG显示器有限公司		
[标]发明人	CHANG YOUN GYOUNG 장윤경 CHO HEUNG LYUL 조흥렬 YOO SOON SUNG 류순성		
发明人	장윤경 조흥렬 류순성		
IPC分类号	G02F1/1345 G02F1/1368 G02F1/136 G02F1/1362 G09F9/30 G09F9/35		
CPC分类号	G02F2001/136236 G02F1/13458 G02F1/136227		
优先权	1020020069578 2002-11-11 KR		
其他公开文献	KR100971955B1		
外部链接	Espacenet		

摘要(译)

本发明涉及液晶显示器，尤其涉及液晶显示器件阵列基板的制作方法。本发明涉及使用3掩模工艺制造液晶显示器阵列基板的方法。并且栅电极，栅极布线和栅极焊盘形成成为第一掩模工艺。有源层，源极，漏极，数据线和数据焊盘电极形成成为第二掩模工艺（半色调掩模用途）。在对掩模进行图案化之后，保护膜进行第三掩模工艺，并且相应的栅极焊盘电极端子接触和数据焊盘电极端子形成有像素电极，以及栅极焊盘电极和数据焊盘电极。可以具有提高价格竞争力的优点，因为如果用于液晶显示器的阵列基板缩短了处理时间并且降低了制造成本，同时可以提高处理产量作为如上所述的3掩模处理。

