



US 20180011368A1

(19) **United States**

(12) **Patent Application Publication**
Son et al.

(10) **Pub. No.: US 2018/0011368 A1**
(43) **Pub. Date: Jan. 11, 2018**

(54) **DISPLAY APPARATUS**

Publication Classification

(71) Applicant: **LG Display Co., Ltd.**, Seoul (KR)
(72) Inventors: **Nam Do Son**, Chilgok-gun (KR); **Song Ryol You**, Goyang-si (KR); **Kyeong Tak Baek**, Daegu (KR); **Seong Rok Kim**, Seoul (KR); **Dong Yong Kim**, Samcheok-si (KR); **Ki Nam Jean**, Gumi-si (KR)

(51) **Int. Cl.**
G02F 1/1333 (2006.01)
(52) **U.S. Cl.**
CPC **G02F 1/133308** (2013.01); **G02F 2001/133322** (2013.01); **G02F 2201/465** (2013.01)

(21) Appl. No.: **15/710,153**

(22) Filed: **Sep. 20, 2017**

Related U.S. Application Data

(62) Division of application No. 12/982,496, filed on Dec. 30, 2010, now Pat. No. 9,804,429.

Foreign Application Priority Data

Apr. 27, 2010 (KR) 10-2010-0039024

(57) **ABSTRACT**

Disclosed is a display apparatus which facilitates minimized thickness by innovatively removing a case and some portions of a set cover, which have been regarded as indispensable structures for the display apparatus, and simultaneously facilitates good aesthetic exterior appearance of the display apparatus by a novel design. The display apparatus comprises a set cover exposed externally to have a storage space; a support cover placed onto the storage space and formed to have a supporting space; a backlight unit received in the supporting space; a guide frame connected to the support cover while being supported by the support cover, and received in the storage space; and a liquid crystal display panel placed onto the guide frame, wherein the liquid crystal display panel displays images by adjusting transmittance of light emitted from the backlight unit.

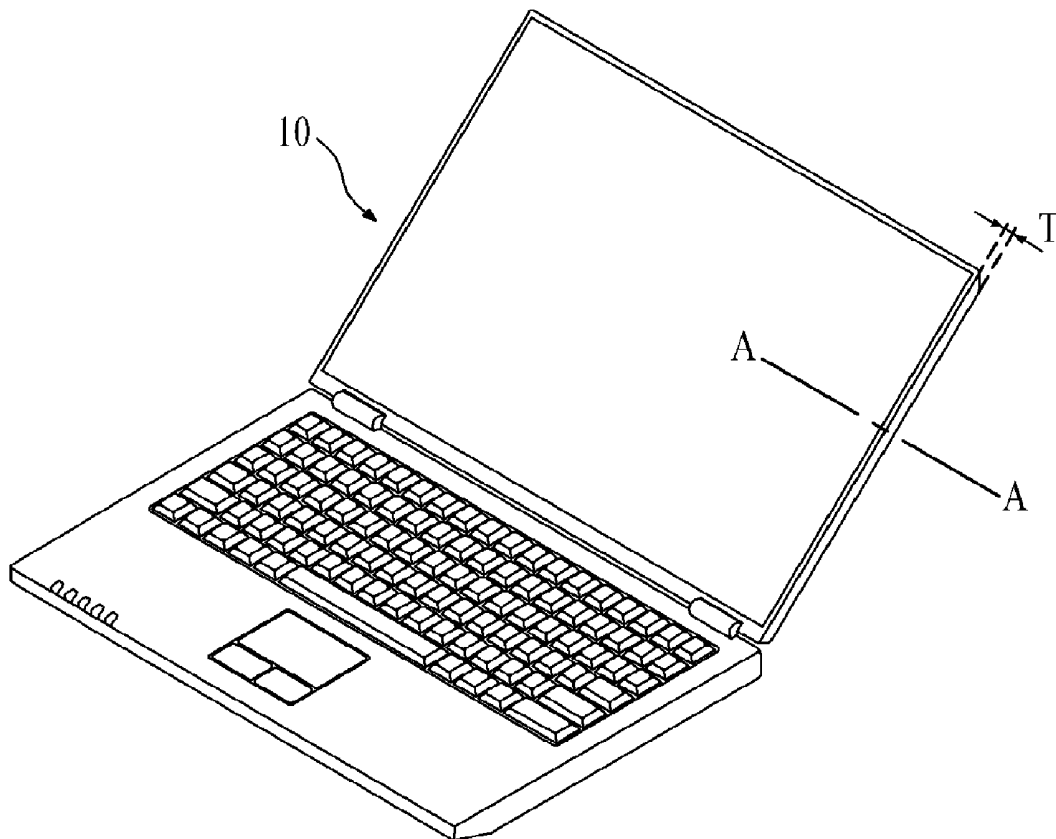

FIG. 1

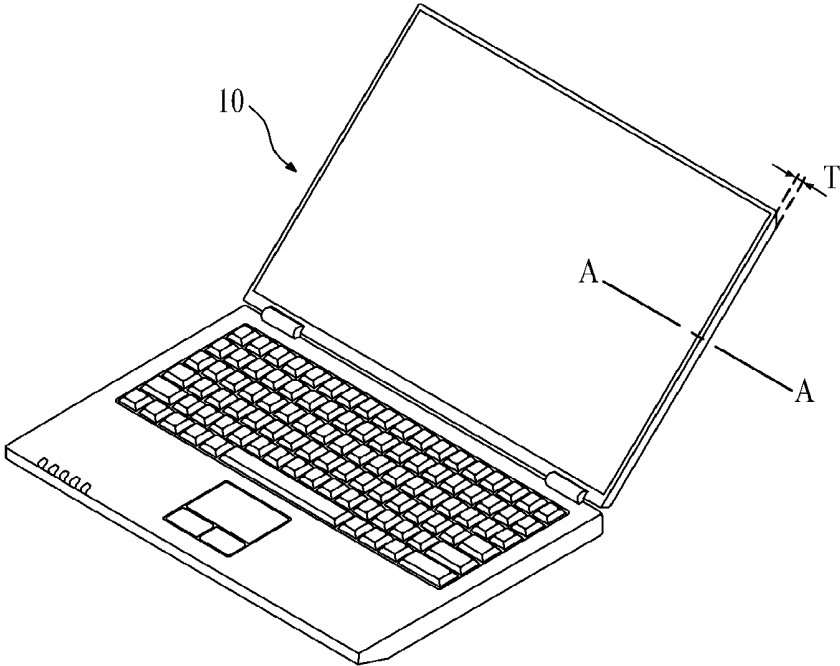

FIG. 2

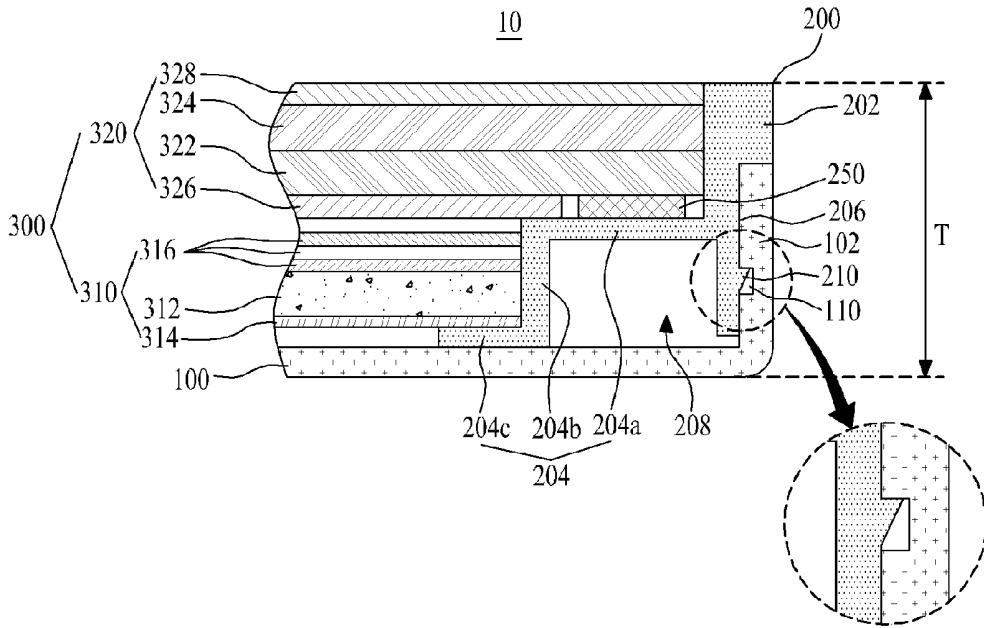

FIG. 3

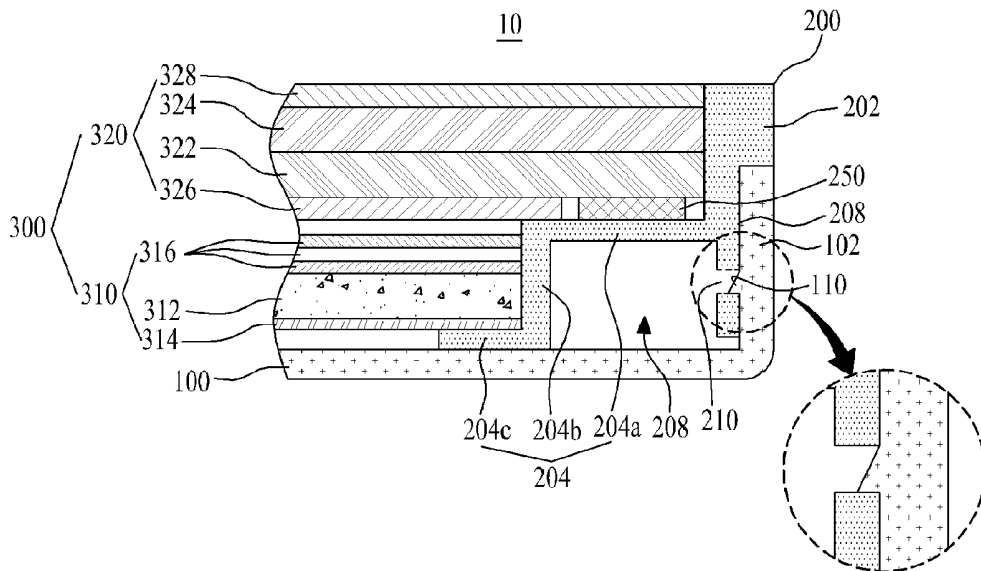

FIG. 4

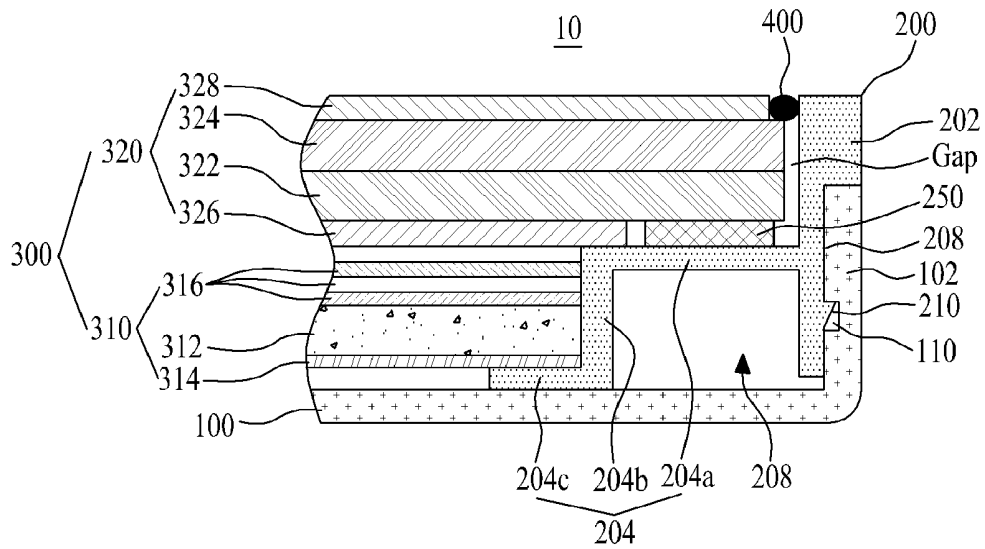

FIG. 5

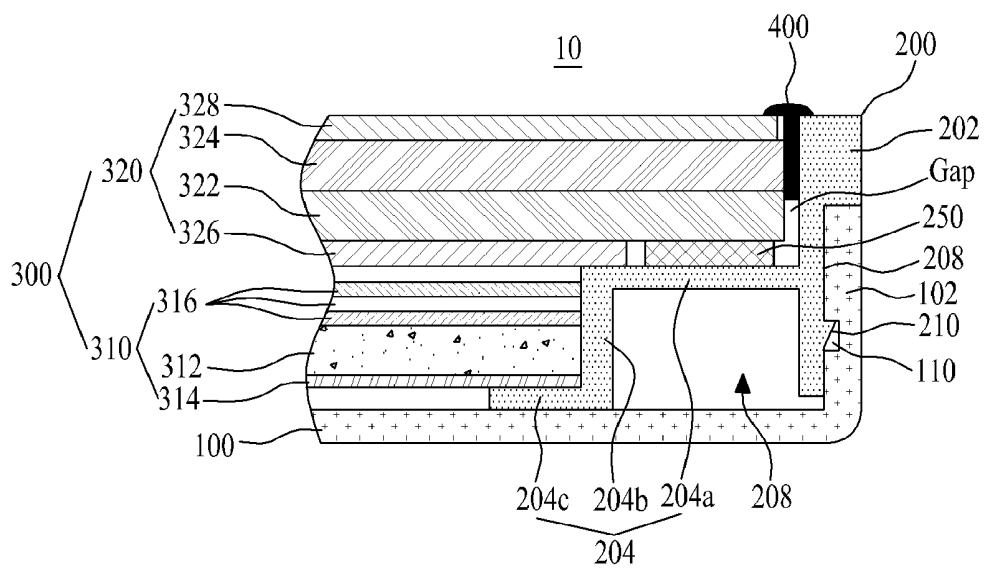

FIG. 6

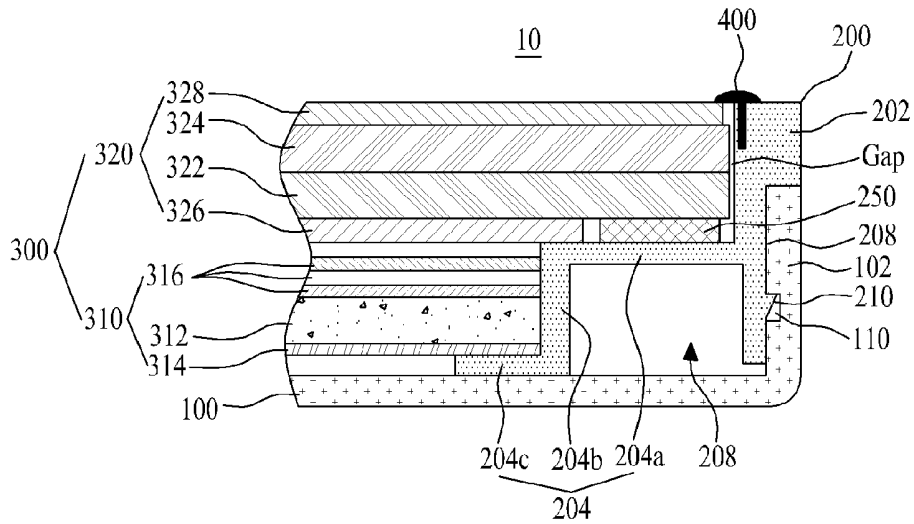

FIG. 7

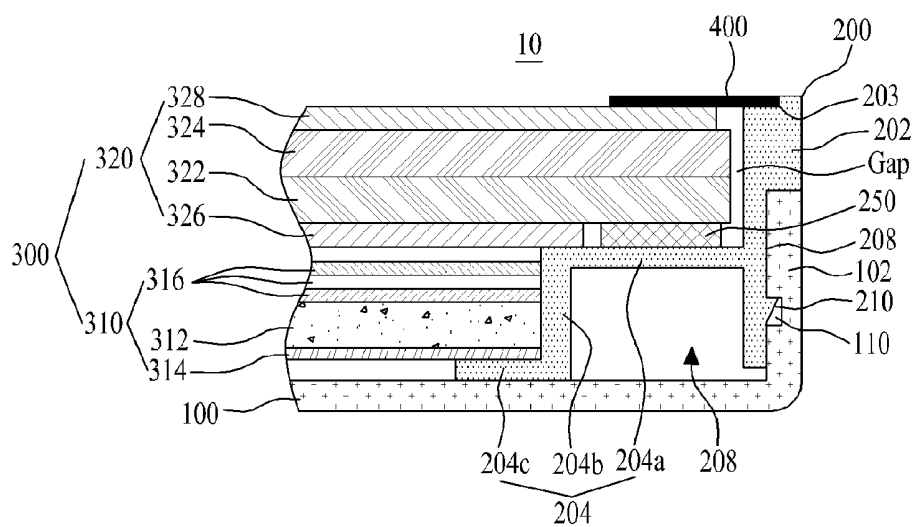

FIG. 8

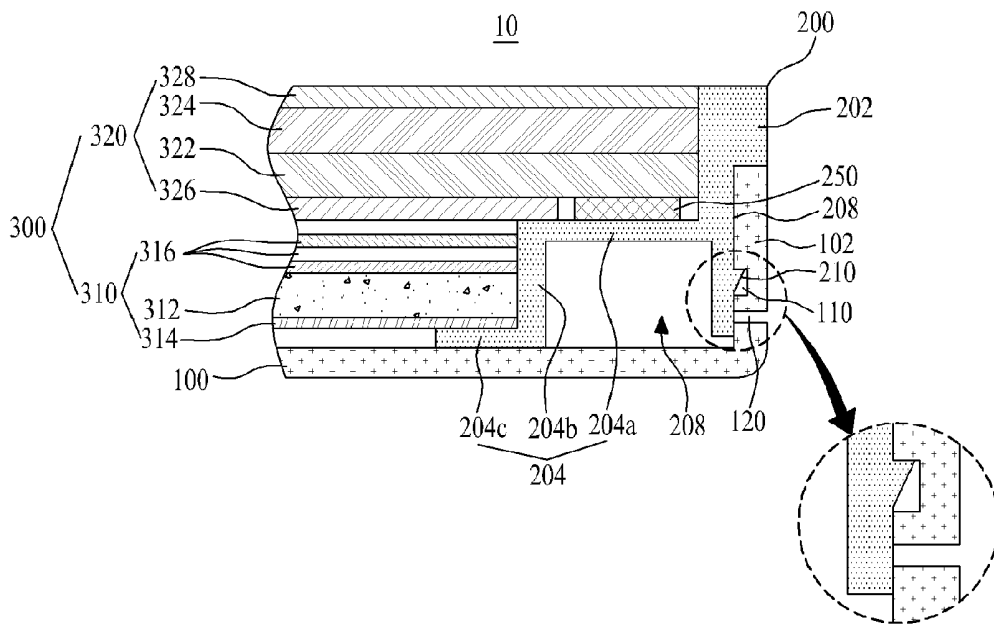

FIG. 9

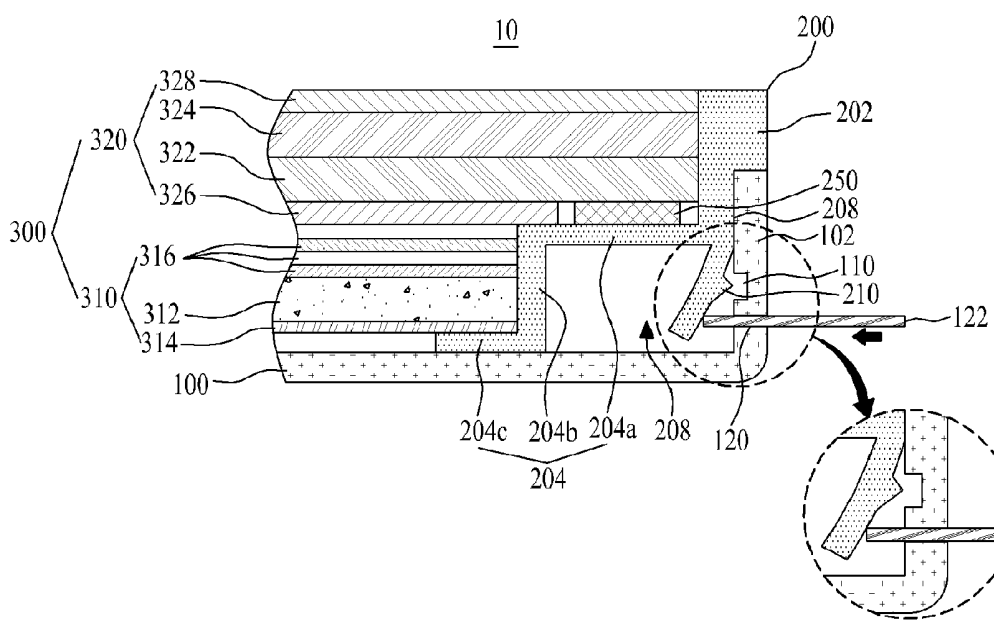

FIG. 10

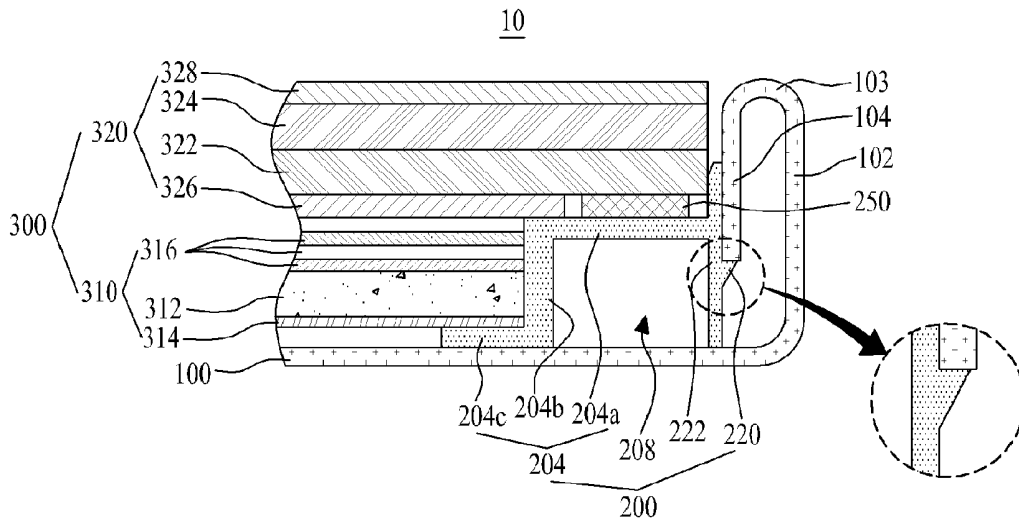

FIG. 11

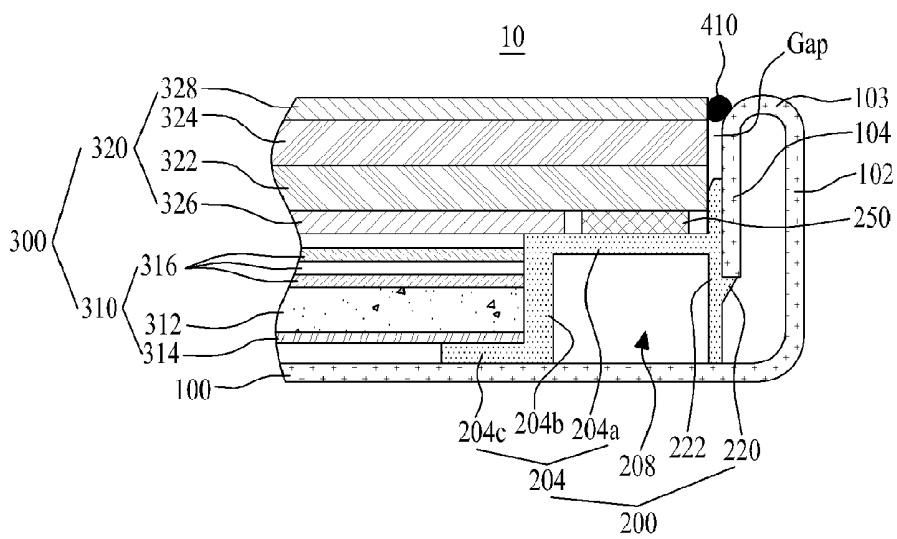

FIG. 12

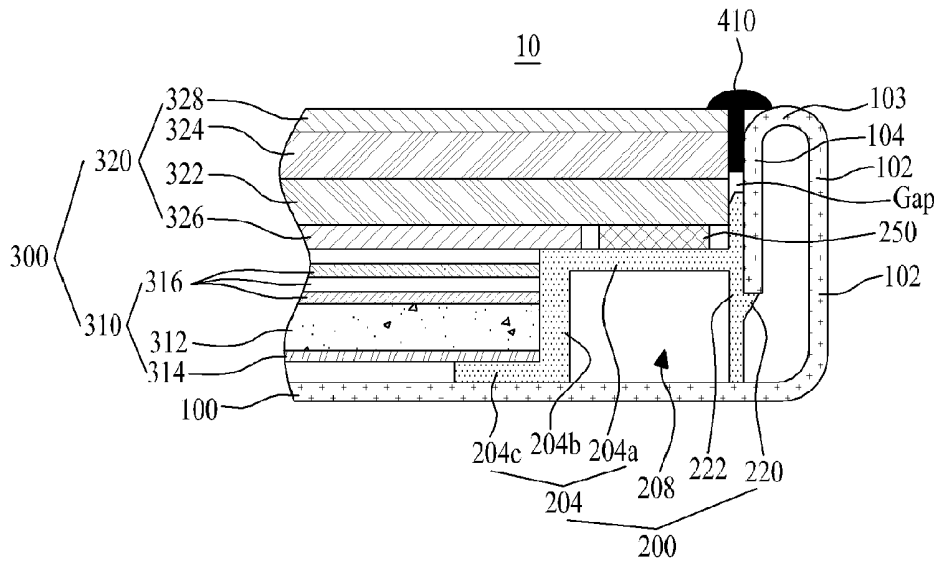

FIG. 13

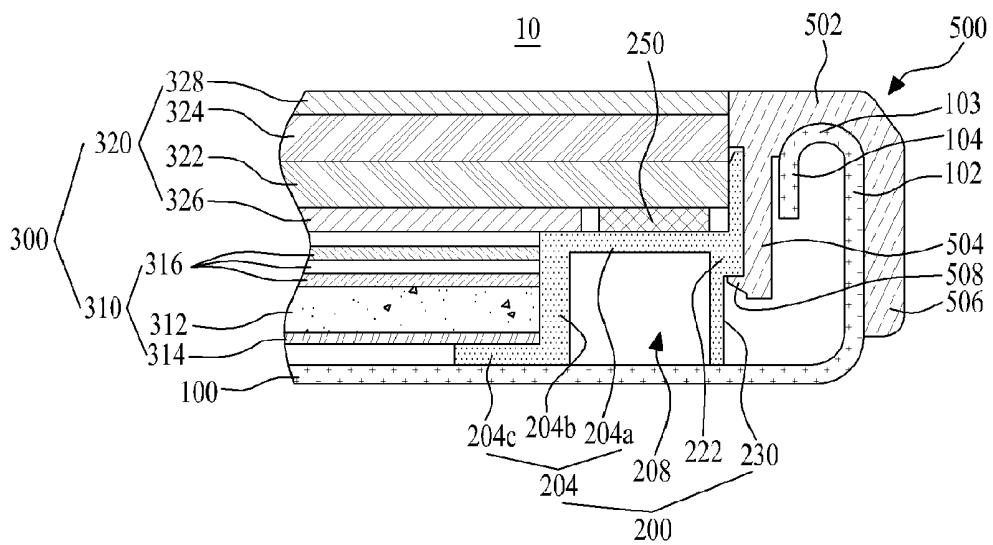

FIG. 14

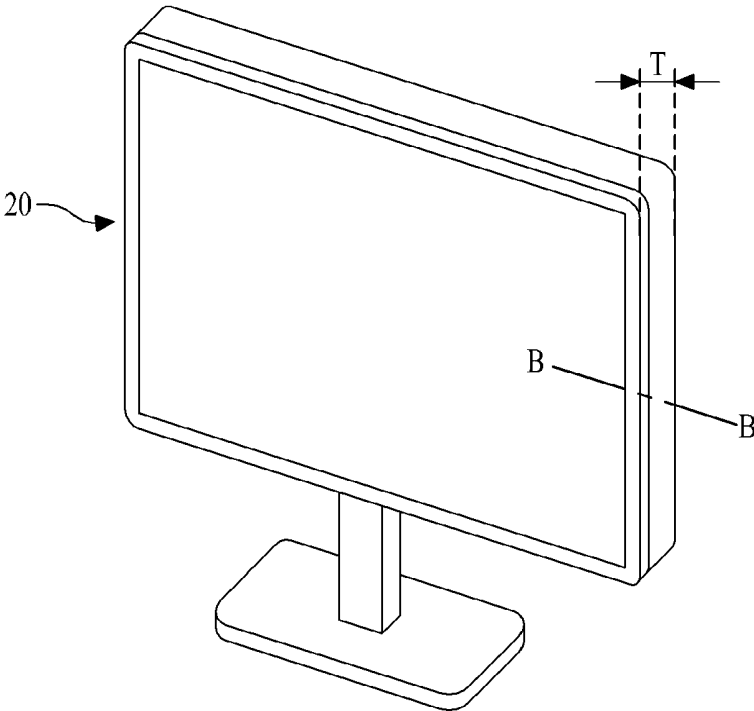

FIG. 15

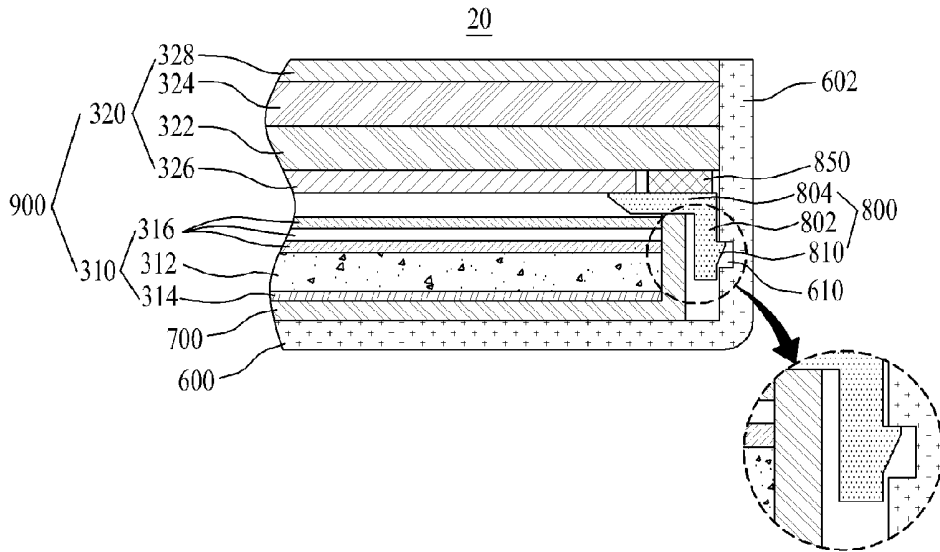

FIG. 16

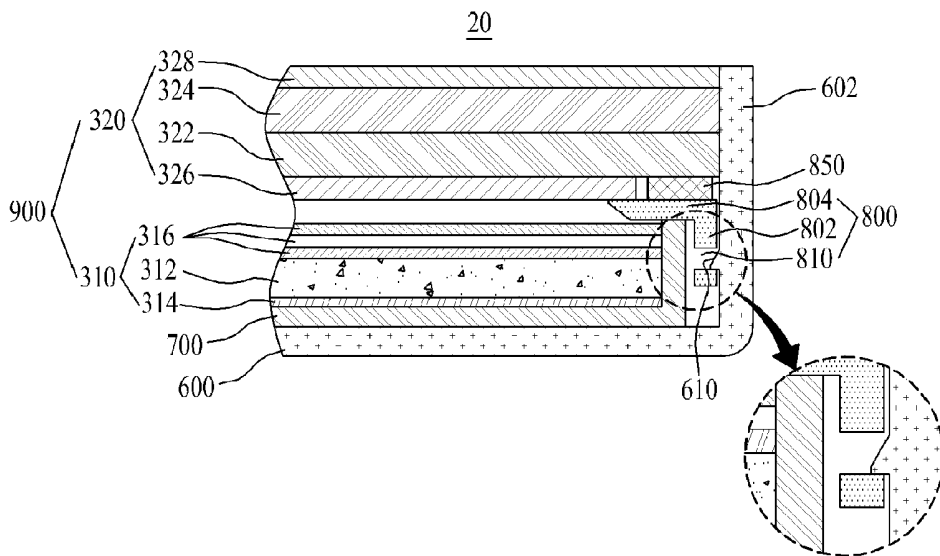

FIG. 17

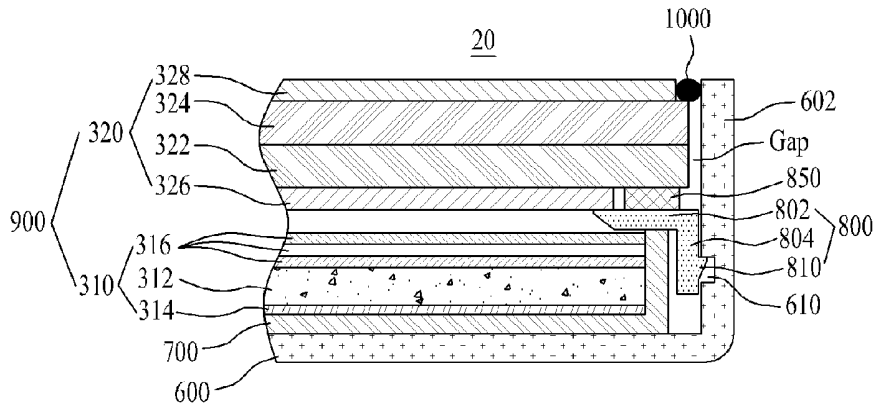

FIG. 18

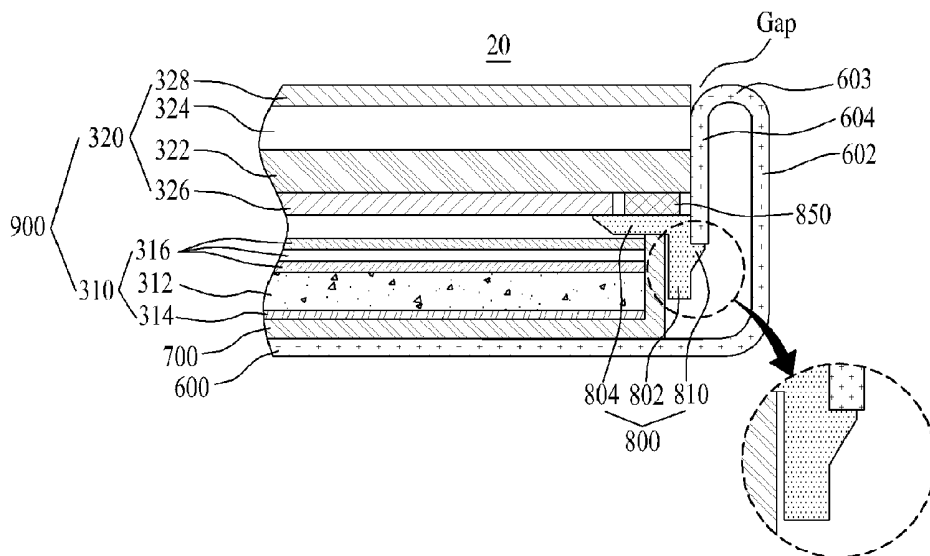

FIG. 19

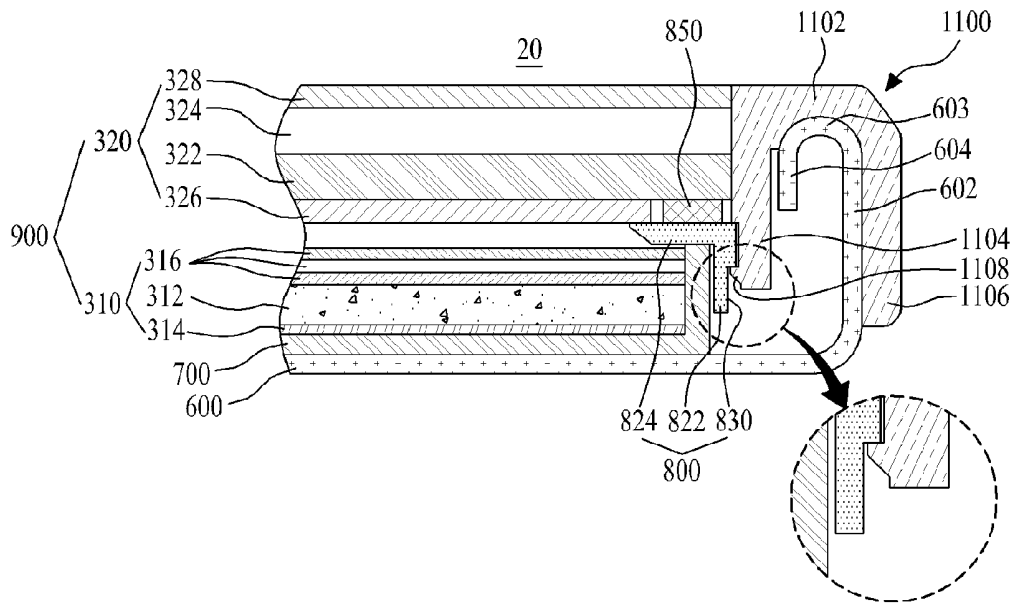
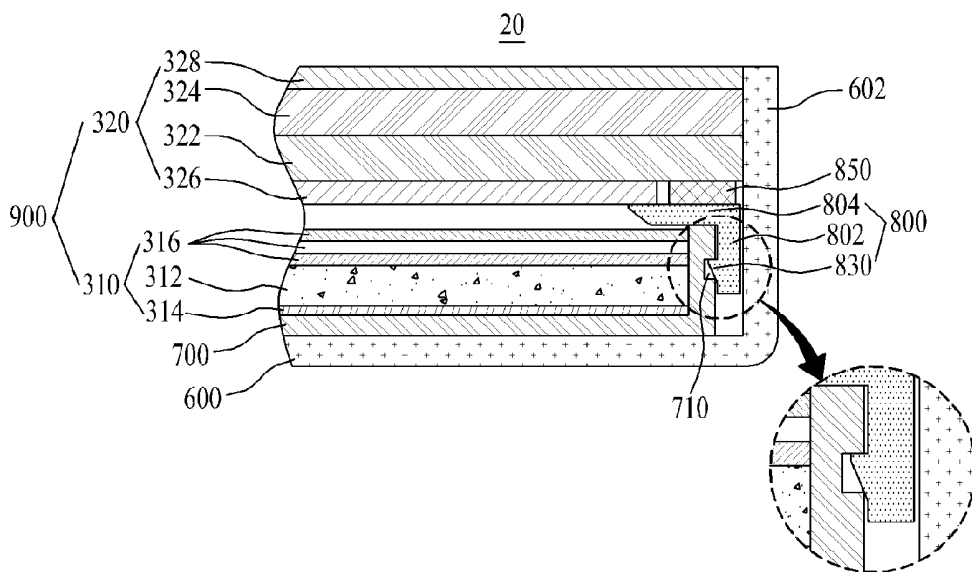

FIG. 20



DISPLAY APPARATUS**CROSS REFERENCE TO RELATED APPLICATIONS**

[0001] This application claims the benefit of the Korean Patent Application No. 10-2010-0039024 filed on Apr. 27, 2010, which is hereby incorporated by reference for all purposes as if fully set forth herein.

BACKGROUND**Field of the Invention**

[0002] The present invention relates to a display apparatus, and more particularly, to a display apparatus which facilitates minimized thickness by innovatively removing a case and some portions of a set cover, which have been regarded as indispensable structures for the display apparatus, and simultaneously facilitates to realize good aesthetic exterior appearance of the display apparatus by a novel design.

Discussion of the Related Art

[0003] Recently, various flat-type display devices have been actively developed and researched to decrease heavy weight and large volume which correspond to disadvantages of Cathode Ray Tubes (CRT), for example, Liquid Crystal Display (LCD) devices, Plasma Display Panels (PDP), Field Emission Display (FED) devices, Light Emitting Display (LED) devices, etc. Especially, among these devices, the LCD device has attracted great attention owing to its advantages such as ability to be mass produced, simple driving means, and high picture quality.

[0004] In addition to the technical aspects of the flat-type display apparatus, there is an increasing demand for research and development of flat-type display apparatus design. This research includes steady efforts toward minimization in thickness of the display apparatus (for example, slimness) while simultaneously increasing satisfactory designs which are capable of arousing customer's interest.

[0005] However, the existing design for the slimness and good aesthetic exterior appearance of the display apparatus has been developed by changing a structure of components included in the display apparatus under the circumstances that all components are used for the display apparatus. Thus, it limits the slimness of the display apparatus and the development of the new design.

[0006] For instance, a related art LCD device necessarily uses lower and upper cases to receive a liquid crystal display unit and a backlight unit therein. In addition, front and rear set covers are additionally used in the related art LCD device to manufacture notebook computers, monitors, mobile devices, or televisions. As the lower and upper cases and the front and rear set covers for the manufactured device are inevitably used in the display device, these limit the slimness of the display device and the development of the new design. Especially, the upper edges of the liquid crystal display panel are covered with the upper case and front set cover, whereby the liquid crystal display device is increased in its thickness. Also, the edge width of the liquid crystal display device is increased so that step coverage of the edge is increased, which might be an obstruction to the development of innovative design.

SUMMARY

[0007] Accordingly, the present invention is directed to a display apparatus that substantially obviates one or more problems due to limitations and disadvantages of the related art.

[0008] An advantage of the present invention is to provide a display apparatus which minimize thickness by innovatively removing a case and some portions of a set cover, which have been regarded as indispensable structures for the display apparatus, and simultaneously facilitates to realize a good aesthetic exterior appearance of the display apparatus by a novel design.

[0009] Additional advantages and features of the invention will be set forth in part in the description which follows and in part will become apparent to those having ordinary skill in the art upon examination of the following or may be learned from practice of the invention. The objectives and other advantages of the invention may be realized and attained by the structure particularly pointed out in the written description and claims hereof as well as the appended drawings.

[0010] To achieve these and other advantages and in accordance with the purpose of the invention, as embodied and broadly described herein, there is provided a display apparatus comprising: a set cover exposed to the external to have a storage space; a support cover placed onto the storage space and formed to have a supporting space; a backlight unit received in the supporting space; a guide frame connected to the support cover while being supported by the support cover, and received in the storage space; and a liquid crystal display panel placed onto the guide frame, wherein the liquid crystal display panel displays images by adjusting transmittance of light emitted from the backlight unit.

[0011] It is to be understood that both the foregoing general description and the following detailed description of the present invention are exemplary and explanatory and are intended to provide further explanation of the invention as claimed.

BRIEF DESCRIPTION OF THE DRAWINGS

[0012] The accompanying drawings, which are included to provide a further understanding of the invention and are incorporated in and constitute a part of this application, illustrate embodiment(s) of the invention and together with the description serve to explain the principle of the invention. In the drawings:

[0013] FIG. 1 illustrates a display apparatus used for a notebook computer according to an exemplary embodiment of the present invention;

[0014] FIG. 2 is a cross section view along A-A of FIG. 1, which illustrates a display apparatus according to a first embodiment of the present invention;

[0015] FIG. 3 illustrates another exemplary embodiment of first and second coupling members shown in FIG. 2;

[0016] FIG. 4 illustrates a display apparatus according to a second exemplary embodiment of the present invention;

[0017] FIG. 5 illustrates the second embodiment of the sealing member shown in FIG. 4;

[0018] FIG. 6 illustrates a third exemplary embodiment of the sealing member shown in FIG. 4;

[0019] FIG. 7 illustrates a fourth exemplary embodiment of the sealing member shown in FIG. 4;

[0020] FIG. 8 illustrates a display apparatus according to the third embodiment of the present invention;

[0021] FIG. 9 illustrates a separation between a guide frame and a set cover through the use of separation hole inserted into a separation hole shown in FIG. 8;

[0022] FIG. 10 illustrates a display apparatus according to a fourth exemplary embodiment of the present invention;

[0023] FIG. 11 illustrates a display apparatus according to a fifth exemplary embodiment of the present invention;

[0024] FIG. 12 illustrates a second exemplary embodiment of the sealing member shown in FIG. 11;

[0025] FIG. 13 illustrates a display apparatus according to a sixth exemplary embodiment of the present invention;

[0026] FIG. 14 illustrates a display apparatus used for a monitor or television according to an embodiment of the present invention;

[0027] FIG. 15 illustrates a display apparatus according to a seventh exemplary embodiment of the present invention;

[0028] FIG. 16 illustrates another exemplary embodiment of first and second coupling members shown in FIG. 15;

[0029] FIG. 17 illustrates a display apparatus according to an eighth exemplary embodiment of the present invention;

[0030] FIG. 18 illustrates a display apparatus according to a ninth exemplary embodiment of the present invention;

[0031] FIG. 19 illustrates a display apparatus according to a tenth exemplary embodiment of the present invention; and

[0032] FIG. 20 illustrates a display apparatus according to an eleventh exemplary embodiment of the present invention.

DETAILED DESCRIPTION OF THE INVENTION

[0033] Reference will now be made in detail to the exemplary embodiments of the present invention, examples of which are illustrated in the accompanying drawings. Wherever possible, the same reference numbers will be used throughout the drawings to refer to the same or like parts.

[0034] Hereinafter, a display apparatus according to the present invention will be described with reference to the accompanying drawings.

[0035] FIG. 1 illustrates a display apparatus used for a notebook computer according to an embodiment of the present invention. FIG. 2 is a cross section view along A-A of FIG. 1, which illustrates a display apparatus according to a first exemplary embodiment of the present invention.

[0036] Referring to FIG. 2, the display apparatus 10 according to a first embodiment of the present invention may include a set cover 100, a guide frame 200, and a display unit 300.

[0037] The set cover 100 may be formed in a rectangular-shaped frame. At this time, the set cover 100 may be provided with a set plate and a set sidewall 102, wherein the set sidewall 102 may be vertically curved from the set plate so as to form a predetermined space. The set cover 100 may support the guide frame 200 and the display unit 300, and simultaneously covers the lateral side of the guide frame 200. In this case, the set cover 100 may be formed of a plastic material or metal material. For the aesthetic exterior appearance, the set cover 100 may be formed of the metal material, preferably.

[0038] The guide frame 200, which may be received in the predetermined space of the set cover 100, may support the display unit 300. For this, the guide frame 200 may comprise

a guide sidewall 202, a supporter 204, a set sidewall insertion groove 206, and a plurality of first coupling members 210.

[0039] The guide sidewall 202 may be vertically formed to cover the lateral side of the display unit 300. In this case, the upper surface of the guide sidewall 202 may be exposed to the external so as to cover the lateral side of the display unit 300, whereby the upper surface of the guide sidewall 202 may form the frontal edge of the display unit 300.

[0040] The supporter 204 may protrude from the guide sidewall 202 while being in opposite to the set sidewall 102, to thereby support the display unit 300. For this, the supporter 204 may comprise a first part 204a, a curved part 204b, and a second part 204c.

[0041] The first part 204a may protrude from the guide sidewall 202 while being in parallel to the set plate.

[0042] The curved part 204b may be vertically curved from one end of the first part 204a toward the set plate.

[0043] The second part 204c may be curved from one end of the curved part 204b while being in parallel to the set plate and being placed onto the set plate.

[0044] The set sidewall insertion groove 206 may be hollowly formed in the lower outer surface of the guide sidewall 202 except the upper outer surface of the guide sidewall 202. The set sidewall insertion groove 206 may be covered by the set sidewall 102 inserted thereto.

[0045] The plurality of first coupling members 210 may be formed in the set sidewall insertion groove 206, and may then be connected to the set sidewall 102 of the set cover 100. For this, the plurality of first coupling members 210 may protrude from the outer surface of the set sidewall insertion groove 206, wherein each of the plural first coupling members 210 may include a stepped surface, and a slant surface which is inclined by a predetermined angle.

[0046] In the inner surface of the set sidewall 102, a plurality of second coupling members 110 may be formed to be respectively coupled to the plurality of first coupling members 210. Each of the plural second coupling members 110 may be formed in a groove shape to be coupled to the slant surface of each of the plural first coupling members 210, to thereby prevent a separation of the guide frame 200.

[0047] Each of the plural first coupling members 210 may be inserted into and coupled to each of the plural second coupling members 110, whereby the set cover 100 and the guide frame 200 are coupled to each other.

[0048] Meanwhile, the guide frame 200 may further comprise an empty room 208 between the curved part 204b of the supporter 204 and the guide sidewall 202. An antenna or antenna wire used for the notebook computer may be arranged in the empty room 208.

[0049] A color of the guide frame 200 may be the same as a color displayed for a non-driving mode of the display unit 300. For example, it is preferable that the guide frame 200 have a black color.

[0050] The display unit 300 may comprise a backlight unit 310 and a liquid crystal display panel 320.

[0051] The backlight unit 310, which may be placed onto the second part 204c of the guide frame 200, emits light to the rear surface of the liquid crystal display panel 320. At this time, the rear side of the backlight unit 310 may be supported by the second part 204c of the guide frame 200, and the lateral side of the backlight unit 310 may be covered by the curved part 204b of the guide frame 200. The

backlight unit **310** may comprise a light guide plate **312**, a reflective sheet **314**, and an optical member **316**.

[0052] The light guide plate **312** may be formed in a flat type to have a light-incidence surface, whereby the light guide plate **312** guides the light, which is emitted from a light source (not shown) and is then incident on the light-incidence surface, toward the liquid crystal display panel **320**. At this time, the light source (not shown) may be formed to include a fluorescent lamp or light emitting diode.

[0053] The reflective sheet **314** may be arranged on the rear surface of the light guide plate **312**, and is also placed onto the second part **204c** of the guide frame **200**. The reflective sheet **314** reflects the light from the light guide plate **312** toward the liquid crystal display panel **320**.

[0054] The optical member **316**, which may be provided on the light guide plate **312**, improves a luminance property of the light advancing toward the liquid crystal display panel **320** from the light guide plate **312**. For this, the optical member **316** may comprise at least two sheets of a lower diffusion sheet, a lower prism sheet, an upper prism sheet, and an upper diffusion sheet.

[0055] The lower diffusion sheet, which is arranged on the light guide plate **312**, diffuses the light incident from the light guide plate **312**, and applies the diffused light to the lower prism sheet.

[0056] The lower prism sheet, which may be arranged on the lower diffusion sheet, concentrates the light incident from the lower diffusion sheet into a first direction, and applies the concentrated light to the upper prism sheet. At this time, the first direction may correspond to a long or short side direction of the light guide plate **312**.

[0057] The upper prism sheet, which may be arranged on the lower prism sheet, concentrates the light incident from the lower prism sheet into a second direction, and applies the concentrated light to the upper diffusion sheet. At this time, the second direction may be perpendicular to the first direction. According to the structure of the backlight unit **310**, the upper prism sheet may be omitted. Also, the lower and upper prism sheets may be substituted by one prism sheet including first and second light-concentrating patterns to concentrate the light from the lower diffusion sheet into the first and second directions. Furthermore, the first and second light-concentrating patterns may be formed on the lower diffusion sheet. If the first and second light-concentrating patterns are formed on the lower diffusion sheet, the lower and upper prism sheets may be omitted.

[0058] The upper diffusion sheet, which may be arranged on the upper prism sheet, diffuses the light incident from the upper prism sheet, and applies the diffused light to the liquid crystal display panel **320**. At this time, if the upper prism sheet is omitted, the upper diffusion sheet may be arranged on the lower prism sheet to diffuse the light incident from the lower prism sheet and to apply the diffused light to the liquid crystal display panel **320**. Also, if both the lower and upper prism sheets are omitted, the upper diffusion sheet may diffuse the light incident from the lower diffusion sheet with the first and second light-concentrating patterns, and apply the diffused light to the liquid crystal display panel **320**.

[0059] The liquid crystal display panel **320** is placed onto the first part **204a** of the guide frame **200**, and is arranged on the backlight unit **310**, whereby the liquid crystal display panel **320** adjusts a transmittance of the light emitted from the backlight unit **310**, to thereby display a predetermined image. At this time, the rear side of the liquid crystal display

panel **320** may be placed onto the first part **204a** of the guide frame **200**, and the lateral side of the liquid crystal display panel **320** may be covered by the guide sidewall **202** of the guide frame **200**.

[0060] The liquid crystal display panel **320** may be placed onto the first part **204a** of the guide frame **200** through the use of adhesive member **250**. At this time, the adhesive member **250** may be a double-sided tape. The adhesive member **250** may be adhered onto the edge of the rear surface of the liquid crystal display panel **320** or onto the first part **204a** of the guide frame **200**, whereby the liquid crystal display panel **320** and the guide frame **200** are stably connected to each other.

[0061] The liquid crystal display panel **320** may comprise a lower substrate **322**, an upper substrate **324**, a lower polarizing plate **326**, and an upper polarizing plate **328**.

[0062] The lower substrate **322** may include a plurality of pixels (not shown) in every regions formed by crossing a plurality of gate lines (not shown) and data lines (not shown). Each pixel may comprise a thin film transistor (not shown) connected to the gate and data lines; a pixel electrode connected to the thin film transistor; and a common electrode formed adjacent to the pixel electrode, wherein a common voltage is applied to the common electrode. The common electrode may be formed on the upper substrate **324** according to a driving mode of liquid crystal layer. The lower substrate **322** may form an electric field corresponding to a differential voltage between the common voltage and data voltage applied to each pixel, to thereby adjust the light transmittance of liquid crystal layer.

[0063] The aforementioned adhesive member **250** may be adhered onto the edge of the lower substrate **322** or the first part **204a**, whereby the lower substrate **322** and the guide frame **322** may be connected to each other.

[0064] The upper substrate **324** may be formed to have a color filter corresponding to each pixel of the lower substrate **322**. The lower and upper substrates **322** and **324** may be bonded to each other with the liquid crystal layer interposed therebetween. At this time, the common electrode supplied with the common voltage may be formed on the upper substrate **324** according to the driving mode of the liquid crystal layer. The incident light passing through the liquid crystal layer may be filtered through the color filter of the upper substrate **324** so that the predetermined colored light is emitted to the external. Accordingly, the predetermined colored image may be displayed on the liquid crystal display panel **320**.

[0065] Meanwhile, a detailed structure of the lower and upper substrates **322** and **324** may vary according to the driving mode of the liquid crystal display panel **320**, for example, Twisted Nematic (TN) mode, Vertical Alignment (VA) mode, In-Plane Switching (IPS) mode, Fringe Field Switching (FFS) mode, and etc., which are generally known to those skilled in the art.

[0066] The lower polarizing plate **326** may be formed on the rear surface of the lower substrate **322**, wherein the lower polarizing plate **326** polarizes the light incident from the backlight unit **310**, and applies the polarized light to the lower substrate **322**. While being overlapped with the optical member **316** of the backlight unit **310**, the lower polarizing plate **326** may be adhered onto the remaining regions except the edge of the rear surface of the lower substrate **322** with the aforementioned adhesive member **250** adhered thereonto.

[0067] The upper polarizing plate 328 may be formed on the entire surface of the upper substrate 324, whereby the light incident through the upper substrate 324 is polarized by the upper polarizing plate 328, and the polarized light is emitted to the external.

[0068] The aforementioned display unit 300 may be formed of a light emitting display unit including a light emitting display panel with an organic light emitting device, instead of the liquid crystal display unit including the backlight unit 310 and the liquid crystal display panel 320. In this case, the guide frame 200 may comprise the first part 204a which supports the guide sidewall 202 covering the lateral surface of the light emitting display unit and the rear surface of the light emitting display unit; the set sidewall insertion groove 206 which is formed in the guide sidewall 202, wherein the set sidewall 102 of the set cover 100 may be inserted into the set sidewall insertion groove 206; and the plurality of first coupling members 210 which may be formed in the set sidewall insertion groove 206, wherein the plurality of first coupling members 210 are respectively coupled to the plurality of second coupling members 110.

[0069] In the display apparatus 10 according to the first exemplary embodiment of the present invention, the plurality of first coupling members 210 in the protrusion type may be formed along the guide sidewall 202, and the plurality of second coupling members 110 in the groove type may be formed along the set sidewall 102, but not necessarily. The first and second coupling members 210 and 110 may be formed in various shapes appropriate for their coupling. For example, as shown in FIG. 3, the plurality of first coupling members 210 may be formed as a groove or hole along the guide sidewall 202; and the plurality of second coupling members 110 may be formed as a protrusion along the set sidewall 102.

[0070] The display apparatus 10 according to the first exemplary embodiment of the present invention may support the display unit 300 through the use of guide frame 200, and connects the guide frame 200 and the set cover 100 to each other, so that it is possible to decrease a total thickness (T) of the device by omitting lower and upper cases, and a front cover of product, which have been essentially used for the related art display apparatus.

[0071] In the display apparatus 10 according to the first embodiment of the present invention, the upper surface of the guide sidewall 202 may be exposed to the external so as to cover the lateral surface of the display unit 300, whereby the upper surface of the guide sidewall 202 forms the frontal edge of the display unit 300. Thus, there is no requirement for an additional structure for covering the upper edge of the display unit 300 and the lateral side of the guide frame 200, to thereby decrease the total thickness (T) of the display apparatus.

[0072] The display apparatus 10 according to the first embodiment of the present invention may minimize the border of the display unit 300 by exposing only the liquid crystal display panel 320 and guide sidewall 202 to a user. Thus, the good aesthetic exterior appearance of the display apparatus may be realized owing to the minimized border of the display unit 300.

[0073] FIG. 4 illustrates a display apparatus according to the second exemplary embodiment of the present invention.

[0074] Referring to FIG. 4, the display apparatus 10 according to the second embodiment of the present invention may include a set cover 100, a guide frame 200, a

display unit 300, and a sealing member 400. Except the sealing member 400, the display apparatus 10 according to the second embodiment of the present invention may be identical in structure to the display apparatus according to the first embodiment of the present invention shown in FIGS. 2 and 3, whereby a detailed explanation for the same parts will be omitted.

[0075] First, when manufacturing the display unit 300, that is, liquid crystal display panel 320 and guide frame 200, a gap may occur between a lateral side of the liquid crystal display panel 320 and a guide sidewall 202 of the guide frame 200 due to a manufacturing error. Accordingly, the sealing member 400 may seal the gap between the lateral side of the liquid crystal display panel 320 and the guide frame 200, and may thereby prevent foreign matters such as dust from coming into the inside of the display apparatus through the gap. At this time, a color of the sealing member 400 may be the same as a color of the guide frame 200, which allows good aesthetic exterior appearance of the display apparatus by preventing a color difference between the sealing member 400 and the guide frame 200.

[0076] For this, the sealing member 400 according to the first embodiment of the present invention may be formed in a ring shape. The ring-shaped sealing member 400 may be inserted into the gap between the lateral side of the liquid crystal display panel 320 and the guide frame 200, to thereby seal the gap. Thus, it is possible to prevent foreign matters such as dust from coming into the inside of the display apparatus through the gap.

[0077] As shown in FIG. 5, the sealing member 400 according to the second embodiment of the present invention may be formed in a pin shape including a semicircular head, and a head supporter for supporting the semicircular head. At this time, the head supporter may be inserted into the gap, and the head is overlapped with the edge of the liquid crystal display panel 320 and the upper surface of the guide sidewall 202 so as to cover the gap. Accordingly, the sealing member 400 may seal the gap between the lateral side of the liquid crystal display panel 320 and the guide frame 200, to thereby prevent foreign matters such as dust from coming into the inside of the display apparatus through the gap.

[0078] As shown in FIG. 6, the sealing member 400 according to the third exemplary embodiment of the present invention may comprise a semicircular head which covers the gap between the lateral side of the liquid crystal display panel 320 and the guide sidewall 202 of the guide frame 200; and a head supporter which may be formed as one body with the upper inner portion of the guide sidewall 202 so as to support the head. In this case, the sealing member 400 may be formed simultaneously with the guide frame 200. That is, the sealing member 400 and the guide frame 200 may be formed by a double injection molding method. Accordingly, the sealing member 400 may seal the gap between the lateral side of the liquid crystal display panel 320 and the guide sidewall 202, to thereby prevent foreign matters such as dust from coming into the inside of the display apparatus through the gap.

[0079] As shown in FIG. 7, the sealing member 400 according to the fourth embodiment of the present invention may be formed in a film type which is adhered to the upper edge of the liquid crystal display panel 320 and simultaneously to the partial portion of the upper surface of the guide frame 200, to thereby seal the gap between the lateral side

of the liquid crystal display panel 320 and the guide sidewall 202 of the guide frame 200. In this case, the film-type sealing member 400 may have 0.2t thickness, but not necessarily. The thickness of the sealing member 400 may be determined within a range to minimize step coverage with the liquid crystal display panel 320, which enables the good aesthetic exterior appearance of the display apparatus.

[0080] Meanwhile, if the film-type sealing member 400 is adhered to the entire upper surface of the guide sidewall 202, the sealing member 400 may be peeled off by a user's contact. In this respect, the sealing member 400 may be adhered to the partial portion of the upper surface of the guide sidewall 202. For this, a sealing member adhesion groove 203 may be formed in the upper surface of the guide sidewall 202, and the sealing member 400 may be adhered to the sealing member adhesion groove 203. Accordingly, the film-type sealing member 400 may be adhered to the liquid crystal display panel 320, that is, between the upper edge of upper polarizing plate and the sealing member adhesion groove 203 of the guide frame 200, to thereby seal the gap between the lateral side of the liquid crystal display panel 320 and the guide sidewall 202. Thus, it is possible to prevent foreign matters such as dust from coming into the inside of the display apparatus through the gap.

[0081] FIG. 8 illustrates a display apparatus according to the third exemplary embodiment of the present invention.

[0082] Referring to FIG. 8, the display apparatus 10 according to the third embodiment of the present invention may include a set cover 100, a guide frame 200, a display unit 300, and a plurality of separation holes 120. Except the separation holes 120, the display apparatus according to the third embodiment of the present invention may be identical in structure to the display apparatus according to the first embodiment of the present invention shown in FIGS. 2 and 3, whereby a detailed explanation for the same parts will be omitted.

[0083] The plurality of separation holes 120 may be provided adjacent to a plurality of second coupling members 110 in a set sidewall 102 of the set cover 100 by penetrating a predetermined portion of the set sidewall 102. When separating the guide frame 200 from the set cover 100 for a rework of the display apparatus 10, the separation hole 120 may enable an easy separation between the guide frame 200 and the set cover 100. Meanwhile, since the plurality of separation holes 120 are exposed at the lateral side of the manufactured display apparatus, each of the plural separation holes 120 may be sealed by an additionally-provided separable sealing cap (not shown) so as to realize good aesthetic exterior appearance of the display apparatus.

[0084] In more detail, when separating the guide frame 200 from the set cover 100 for the rework of the display apparatus 100, a worker may first separate the sealing cap from the separation hole 120, as shown in FIG. 9, and then may insert an additional separation pin member 122 into the separation hole 120, whereby the guide sidewall 202 of the guide frame 200 may be forcibly pushed so that the first coupling member 210 is separated from the second coupling member 110. Accordingly, the worker may separate the guide frame 200 from the set cover 100 with ease.

[0085] For the aforementioned explanation, the separation hole 120 may be formed in the set sidewall 102 while being adjacent to the plurality of second coupling members 110, but not necessarily. Instead, the separation hole 120 may penetrate through the plurality of second coupling members

110 of the groove type. At this time, the separation hole 120 may be formed in the plurality of second coupling members 110 and exposed externally and may be sealed by the aforementioned sealing cap.

[0086] The display apparatus 10 according to the third embodiment of the present invention may additionally comprise any one among the sealing members 400 according to the first to fourth exemplary embodiments of the present invention shown in FIGS. 4 to 7.

[0087] The display apparatus 10 according to the third embodiment of the present invention may provide the same effect as those of the aforementioned first and second embodiments of the present invention, and allows the separation between the guide frame 200 and the set cover 100 with ease through the use of separation pin member 122 inserted into the separation hole 120.

[0088] FIG. 10 illustrates a display apparatus according to the fourth exemplary embodiment of the present invention.

[0089] Referring to FIG. 10, the display apparatus 10 according to the fourth embodiment of the present invention may include a set cover 100, a guide frame 200, and a display unit 300. Except the set cover 100 and the guide frame 200, the display apparatus according to the fourth embodiment of the present invention may be identical in structure to the display apparatus according to the first embodiment of the present invention shown in FIGS. 2 and 3, whereby a detailed explanation for the same parts will be omitted.

[0090] The set cover 100 may comprise a set plate, a set sidewall 102, a bending part 103, and an inner sidewall 104.

[0091] The set plate supports the guide frame 200 onto which the display unit 300 is placed.

[0092] The set sidewall 102 may be vertically bent from the set plate, to thereby provide a predetermined space for receiving the guide frame 200 therein.

[0093] The bending part 103 with a predetermined curvature may be bent from one end of the set sidewall 102 toward the display unit 300. The bending part 103 may be exposed to the external so as to cover the lateral side of the display unit 300, whereby the bending part 103 may form the frontal edge of the display unit 300.

[0094] The inner sidewall 104 may be vertically extended from one end of the bending part 103 while being in parallel to the set sidewall 102, and may then connect to the guide frame 200.

[0095] The guide frame 200 may be connected to the inner sidewall 104 of the set cover 100, so that the guide frame 200 supports the display unit 300 received inside the set cover 100. At this time, a color of the guide frame 200 may be the same as a color displayed for a non-driving mode of the display unit 300. For example, it is preferable that the guide frame 200 have a black color. For this, the guide frame 200 may comprise a guide sidewall 222, a supporter 204, and a first coupling member 220.

[0096] The guide sidewall 222 may be formed in parallel to the set sidewall 102, to thereby cover some parts of the lateral side of the display unit 300.

[0097] The supporter 204 may protrude from the guide sidewall 222 while being in an opposite direction to the set sidewall 102, to thereby support the display unit 300. For this, the supporter 204 comprises a first part 204a, a curved part 204b, and a second part 204c, which may be identical to those of the first embodiment of the present invention,

whereby a detailed explanation for structures of the first part **204a**, curved part **204b**, and second part **204c** will be omitted.

[0098] Meanwhile, the guide frame **200** may further comprise an empty room **208** between the guide sidewall **222** and the curved part **204b**. An antenna or antenna wire used for a notebook computer, and a power supply cable of the backlight unit **310** may be arranged in the empty room **208**.

[0099] The plurality of first coupling members **220** may be formed in the guide sidewall **222**, and are connected to the inner sidewall **104** of the set cover **100**. For this, the plurality of first coupling members **220** may protrude from the outer surface of the guide sidewall **222**, wherein each of the plurality of first coupling members **220** include a stepped surface, and a slant surface which is inclined by a predetermined angle. Accordingly, as the stepped surface of each of the plurality of first coupling members **220** is constrained by a lower end of the inner sidewall **104**, the set cover **100** and the guide frame **200** may be connected to each other. At this time, the inner sidewall **104** may be defined as the second coupling member connected to the first coupling member **220**.

[0100] In the display apparatus **10** according to the fourth embodiment of the present invention, the bending part **103** in the set cover **100** may be connected to the guide frame **200**, and the lateral side of the display unit **300** may be covered by the bending part **103**, to thereby decrease a total thickness of the display apparatus, and to realize good aesthetic exterior appearance through the bending part **103**.

[0101] FIG. 11 illustrates a display apparatus according to the fifth exemplary embodiment of the present invention.

[0102] Referring to FIG. 11, the display apparatus **10** according to the fifth embodiment of the present invention may include a set cover **100**, a guide frame **200**, a display unit **300**, and a sealing member **410**. Except the sealing member **410**, the display apparatus **10** according to the fifth embodiment of the present invention may be identical in structure to the display apparatus according to the fourth embodiment of the present invention shown in FIG. 10, whereby a detailed explanation for the same parts will be omitted.

[0103] The sealing member **410** according to the first embodiment of the present invention may be formed in a ring shape which is inserted into a gap between a lateral side of a liquid crystal display panel **320** and a bending part **103** so as to seal the gap. This may be identical to the sealing member **400** of the first embodiment in the aforementioned display apparatus according to the second embodiment of the present invention.

[0104] As shown in FIG. 12, the sealing member **410** according to the second embodiment of the present invention may be formed in a pin shape which may be inserted into the gap between the lateral side of the liquid crystal display panel **320** and the bending part **103** so as to seal the gap. This may be identical to the sealing member **400** of the second embodiment in the aforementioned display apparatus according to the second embodiment of the present invention. That is, the pin-shaped sealing member **410** may comprise a semicircular head, and a head supporter for supporting the semicircular head.

[0105] The display apparatus **10** according to the fifth embodiment of the present invention may seal the gap between the lateral side of the liquid crystal display panel **320** and the bending part **103** through the use of ring-shaped

or pin-shaped sealing member **410**, so that it may be possible to prevent foreign matters such as dust from coming into the inside of the display apparatus through the gap. This may enable to provide the same effects as those of the aforementioned display apparatus according to the fourth embodiment of the present invention.

[0106] FIG. 13 illustrates a display apparatus according to the sixth exemplary embodiment of the present invention.

[0107] Referring to FIG. 13, the display apparatus **10** according to the sixth embodiment of the present invention may include a set cover **100**, a guide frame **200**, a display unit **300**, and an edge frame **500**. Except the guide frame **200** and edge frame **500**, the display apparatus **10** according to the sixth embodiment of the present invention may be identical to the display apparatus according to the fourth embodiment of the present invention shown in FIG. 10, whereby a detailed explanation for the same part will be omitted.

[0108] The guide frame **200**, which may be received inside the set cover **100**, supports the display unit **300**. At this time, a color of the guide frame **200** may be the same as a color displayed for a non-driving mode of the display unit **300**. For example, it is preferable that the guide frame **200** have a black color.

[0109] The guide frame **200** may comprise a guide sidewall **222**, a supporter **204**, and a first coupling member **230**.

[0110] The guide sidewall **222**, which may be formed in parallel to a set sidewall **102** of the set cover **100**, covers the lateral side of the display unit **300**. At this time, the guide sidewall **222** may be provided at a predetermined interval from a bending part **103**.

[0111] The supporter **204** protruding from the guide sidewall **222** may be formed in opposite to the set sidewall **102**, to thereby support the display unit **300**. For this, the supporter **204** may comprise a first part **204a**, a curved part **204b**, and a second part **204c**, which may be identical to those of the first embodiment of the present invention, whereby a detailed explanation for structures of the first part **204a**, curved part **204b**, and second part **204c** will be omitted.

[0112] The first coupling member **230** may be hollowly formed to have a stepped surface in the outer lower surface of the guide sidewall **222**, and may be connected to the edge frame **500**.

[0113] Meanwhile, the guide frame **200** may further comprise an empty room **208** between the guide sidewall **222** and the curved part **204b**. An antenna or antenna wire used for a notebook computer, and a power supply cable of the backlight unit **310** may be arranged in the empty room **208**.

[0114] The guide frame **200** may be connected to the set cover **100** through the use of adhesive member (for example, double-sided tape, not shown) formed between the second part **204c** and the set plate of the set cover **100**.

[0115] The edge frame **500** may be formed in shape “∩” to be connected to the guide frame **200**. The ∩-shaped edge frame **500** may be inserted between the lateral side of the display unit **300** and the inner sidewall **104** of the set cover **100**, and simultaneously cover the bending part **103** of the set cover **100** and the outer side of the set sidewall **102**, whereby the edge frame **500** forms the frontal edge of the display unit **300**. For this, the edge frame **500** may comprise a front part **502**, an inner protrusion **504**, an outer protrusion **506**, and a plurality of second coupling members **508**.

[0116] The front part **502**, which may be arranged to be in contact with the lateral side of the display unit **300**, may cover the space between the lateral side of the liquid crystal display panel **320** and the bending part **103**, and also may cover the entire sides of the bending part **103**, to thereby form the frontal edge of the display unit **300**.

[0117] The inner protrusion **504**, which may vertically protrude from one end of the front part **502**, may be inserted into the space between the lateral side of the display unit **300** and the inner sidewall **104** of the set cover **100**, to thereby seal the space between the lateral side of the display unit **300** and the bending part **103**.

[0118] The outer protrusion **506**, which may vertically protrude from the other end of the front part **502**, may cover the outer sides of the set sidewall **102**.

[0119] The set sidewall **102**, bending part **103**, and inner sidewall **104** of the set cover **100** may be inserted into the \cap -shaped space prepared between the inner protrusion **504** and the outer protrusion **506**.

[0120] The plurality of second coupling members **508** may be provided at fixed intervals, wherein the plurality of second coupling members **508** may protrude from the outer surface of the inner protrusion **504** toward the guide frame **200**. Each of the plural second coupling members **508** may include a slant portion which is provided for a smooth connection to the guide frame **200**; and a stepped portion which is coupled to the stepped surface of frame connection groove **230** in the guide frame **200**.

[0121] The display apparatus **10** according to the sixth embodiment of the present invention may cover the structures provided at the lateral side of the display unit **300** through the use of edge frame **500** connected to the guide frame **200**, to thereby prevent the foreign matters from coming into the inside of the display apparatus. This may enable to provide the same effects as those of the aforementioned display apparatus according to the first embodiment of the present invention.

[0122] FIG. **14** illustrates a display apparatus used for a monitor and television according to an exemplary embodiment of the present invention. FIG. **15** is a cross section view along B-B of FIG. **14**, which illustrates a display apparatus according to the seventh exemplary embodiment of the present invention.

[0123] Referring to FIG. **15**, the display apparatus **20** according to the seventh embodiment of the present invention may include a set cover **600**, a support cover **700**, a guide frame **800**, and a display unit **900**.

[0124] The set cover **600** may be formed in a rectangular-shaped frame type including a set plate and a set sidewall **602**, wherein the set sidewall **602** may be vertically curved from the set plate so as to provide a predetermined space. The set cover **600** may support the guide frame **800** and the display unit **900**, and simultaneously cover the lateral side of the guide frame **800**. In this case, the set cover **600** may be formed of a plastic material or metal material. For good aesthetic exterior appearance, the set cover **600** may preferably be formed of metal material.

[0125] The support cover **700** may be placed onto the set plate of the set cover **600**, and the support cover **700** supports the guide frame **800** and the display unit **900**. For this, the support cover **700** may comprise a support plate which is placed onto the set plate of the set cover **600**; and a support sidewall which may be vertically curved from the support plate. Preferably, the support cover **700** may be

formed of the metal material so as to smoothly dissipate heat generated in the display unit **900**. The support cover **700** may be connected to the set cover **600** through the use of an adhesive member (for example, double-sided tape) or coupling member (for example, screw). Preferably, the support cover **700** may be connected to the set cover **600** through the use of a coupling member.

[0126] The guide frame **800**, which may be placed on the support sidewall of the support cover **700**, supports the display unit **900**. Also, the guide frame **800** may be connected to the set cover **600**. For this, the guide frame **800** may be formed in a rectangular band, which comprises a guide sidewall **802**, a supporter **804**, and a plurality of first coupling members **810**.

[0127] The guide sidewall **802** facing toward the set sidewall **602** may be formed in parallel to the set sidewall **602**, and the guide sidewall **802** may be inserted between the support sidewall of the support cover **700** and the set sidewall **602**.

[0128] The supporter **804** may be curved from an upper end of the guide sidewall **802** so that the supporter **804** may be placed onto the support sidewall of the support cover **700**, to thereby support the display unit **900**.

[0129] The plurality of first coupling members **810** may be formed in the guide sidewall **802**, and may be connected to the set sidewall **602** of the set cover **600**. For this, the plurality of first coupling members **810** may protrude from the outer surface of the guide sidewall **802**, wherein each of the plural first coupling members **810** may include a stepped surface, and a slant surface which may extend from the stepped surface while being inclined by a predetermined angle.

[0130] In the inner surface of the set sidewall **602**, a plurality of second coupling members **610** may be formed to be respectively coupled to the plurality of first coupling members **810**. Each of the plurality of second coupling members **610** may be formed in a groove shape and may be coupled to the slant surface of each of the plurality of first coupling members **810**, to thereby prevent a separation of the guide frame **600**. Here, the aforementioned separation hole shown in FIGS. **8** and **9** may be formed in the plurality of second coupling members **610**, and the separation hole may be sealed by the sealing cap.

[0131] Each of the plurality of first coupling members **810** may be inserted into and coupled to each of the second coupling members **610**, whereby the set cover **600** and the guide frame **800** may be connected to each other.

[0132] As explained in the first embodiment of the present invention, the display unit **900** may be formed of the liquid crystal display unit including the backlight unit **310** and the liquid crystal display panel **320**; or may be formed of the light-emitting display unit including the light-emitting display panel, and their detailed explanations will be omitted.

[0133] If the display unit **900** corresponds to the liquid crystal display unit, the backlight unit **310** may be received in and supported by the support cover **700**; and the liquid crystal display panel **320** may be placed onto and connected to the supporter **804** of the guide frame **800** through the use of adhesive member **850** (for example, double-sided tape).

[0134] If the display unit **900** corresponds to the light-emitting display unit, the light-emitting display unit may comprise the light-emitting display panel without the backlight unit. Thus, the light-emitting display panel may be placed onto and connected to the supporter **804** of the guide

frame **800** through the use of adhesive member **850** (for example, double-sided tape). At this time, the support cover **700** may be formed in a flat plate for dissipation of the heat generated in the light-emitting display panel, or may be omitted.

[0135] In the display apparatus **20** according to the seventh embodiment of the present invention, the plurality of first coupling members **810** may be formed in the protrusion type along the guide sidewall **802**, and the plurality of second coupling members **610** may be formed in the groove type along the set sidewall **602**, but not necessarily. The first and second coupling members **810** and **610** may be formed in various shapes for their coupling. For example, as shown in FIG. **16**, the plurality of first coupling members **810** may be formed as a groove or hole along the guide sidewall **802**; and the plurality of second coupling members **610** may be formed as a protrusion along the set sidewall **602**.

[0136] In the display apparatus **20** according to the seventh embodiment of the present invention, the display unit **900** may be supported by the guide frame **800**, and the guide frame **800** and the set cover **600** may be connected to each other. This may provide the same effects as those of the aforementioned display apparatus according to the first embodiment of the present invention.

[0137] FIG. **17** illustrates a display apparatus according to an eighth exemplary embodiment of the present invention.

[0138] Referring to FIG. **17**, the display apparatus **20** according to the eighth embodiment of the present invention may include a set cover **600**, a support cover **700**, a guide frame **800**, a display unit **900**, and a sealing member **1000**. Except that the sealing member **1000** may be additionally provided, the display unit **20** according to the eighth embodiment of the present invention may be identical in structure to the display unit according to the seventh embodiment of the present invention shown in FIG. **15** or **16**, whereby a detailed explanation for the same parts will be omitted.

[0139] The sealing member **1000** according to the first embodiment of the present invention may be formed in a ring shape to be inserted into a gap between a lateral side of a liquid crystal display panel **320** and a set sidewall **602**, to thereby seal the gap. This may be identical to the sealing member **400** of the first embodiment in the aforementioned display apparatus according to the second embodiment of the present invention.

[0140] In the same manner as the sealing member **400** shown in FIG. **5**, the sealing member **1000** according to the second embodiment of the present invention may be formed in a pin shape and may be inserted into the gap between the lateral side of the liquid crystal display panel **320** and the set sidewall **602** so as to seal the gap, wherein the pin-shaped sealing member **1000** may comprise a semicircular head, and a head supporter for supporting the semicircular head.

[0141] In the same manner as the sealing member **400** shown in FIG. **7**, the sealing member **1000** according to the third embodiment of the present invention may be formed in a film type which may be adhered to the upper edge of the liquid crystal display panel **320** and simultaneously to the partial portion of the upper surface of the set sidewall **602**, to thereby seal the gap between the lateral side of the liquid crystal display panel **320** and the set sidewall **602**.

[0142] Meanwhile, if the film-type sealing member **1000** is adhered to the entire upper surface of the set sidewall **602**, the sealing member **1000** may be peeled off by a user's

contact. In this respect, the sealing member **1000** may be adhered to the partial portion of the upper surface of the set sidewall **602**. For this, a sealing member adhesion groove (not shown) may be formed in the upper surface of the set sidewall **602**, and the sealing member **1000** may be adhered to the sealing member adhesion groove. Accordingly, the film-type sealing member **1000** may be adhered to the liquid crystal display panel **320**, that is, between the upper edge of upper polarizing plate and the sealing member adhesion groove of the set sidewall **602**, to thereby seal the gap between the lateral side of the liquid crystal display panel **320** and the set sidewall **602**.

[0143] FIG. **18** illustrates a display apparatus according to a ninth exemplary embodiment of the present invention.

[0144] Referring to FIG. **18**, the display apparatus **20** according to the ninth embodiment of the present invention may include a set cover **600**, a support cover **700**, a guide frame **800**, and a display unit **900**. Except the set cover **600**, the display apparatus **20** according to the ninth embodiment of the present invention may be identical in structure to the display apparatus according to the seventh or eighth embodiment of the present invention shown in FIGS. **15** to **17**, whereby a detailed explanation for the same parts will be omitted.

[0145] The set cover **600** may comprise a set plate, a set sidewall **602**, a bending part **603**, and an inner sidewall **604**.

[0146] The set plate may support the guide frame **800** and the display unit **900**.

[0147] The set sidewall **602** may be vertically curved from the set plate so as to provide a predetermined space.

[0148] The bending part **603** with a predetermined curvature may be bent from one end of the set sidewall **602** toward the display unit **900**. The bending part **603** may be exposed externally so as to cover the lateral side of the display unit **900**, whereby the bending part **603** forms the frontal edge of the display unit **900**.

[0149] The inner sidewall **604** may be vertically extended from one end of the bending part **603** while being in parallel to the set sidewall **602**, and may then be connected to a first coupling member **810** of the guide frame **800**. That is, a stepped surface of the first coupling member **810** in the guide frame **800** may be connected to a lower end of the inner sidewall **104** so that the set cover **600** and the guide frame **800** may be connected to each other. Here, the inner sidewall **604** may be defined as a second coupling member connected to the first coupling member **810**.

[0150] The display apparatus **20** according to the ninth embodiment of the present invention may further comprise the sealing member (not shown) for sealing the gap between the liquid crystal display panel **320** and the set sidewall **602**. At this time, the sealing member may be formed in the ring shape shown in FIG. **4**; or may be formed in the pin shape shown in FIG. **5**.

[0151] In the display apparatus **20** according to the ninth embodiment of the present invention, the inner sidewall **604** in the set sidewall **602** of the set cover **600** may be connected to the guide frame **800**, and the frontal edge of the display unit **900** may be formed by the bending part **603**, to thereby decrease a total thickness of the display apparatus, and to realize the good aesthetic exterior appearance of the display apparatus.

[0152] FIG. **19** illustrates a display apparatus according to a tenth exemplary embodiment of the present invention.

[0153] Referring to FIG. 19, the display apparatus 20 according to the tenth embodiment of the present invention may include a set cover 600, a support cover 700, a guide frame 800, a display unit 900, and an edge frame 1100. Except the guide frame 800 and edge frame 1100, the display apparatus 20 according to the tenth embodiment of the present invention may be identical in structure to the display apparatus according to the ninth embodiment of the present invention shown in FIG. 18, whereby a detailed explanation for the same parts will be omitted. However, while the display apparatus according to the ninth embodiment of the present invention may have the structure for connecting the set cover 600 and the guide frame 800 to each other, the display apparatus according to the tenth embodiment of the present invention may have the structure for connecting the guide frame 800 and the edge frame 1100 to each other.

[0154] The guide frame 800 may support the display unit 900 while being placed onto a support sidewall of the support cover 700; and the guide frame 800 may be connected to the edge frame 1100. For this, the guide frame 800 may be formed in a rectangular band, which may comprise a guide sidewall 822, a supporter 824, and a first coupling member 830.

[0155] The guide sidewall 822 facing toward a set sidewall 602 of the set cover 600 may be formed in parallel to the set sidewall 602, and the guide sidewall 822 may be inserted between the support sidewall of the support cover 700 and an inner sidewall 604 of the set cover 600.

[0156] The supporter 824 may be curved from an upper end of the guide sidewall 822 so that the supporter 824 may be placed onto the support sidewall of the support cover 700, to thereby support the display unit 900. That is, the supporter 824 may be connected to a rear surface of a liquid crystal display panel 320 of the display unit 900 through the use of adhesive member 850.

[0157] The first coupling member 830 may be hollowly formed to have a stepped surface in the outer lower surface of the guide sidewall 822, and is connected to the edge frame 1100.

[0158] The edge frame 1100 may be formed in shape “fl” to be connected to the guide frame 200, to thereby form the edge of the display unit 900. For this, the edge frame 1100 may comprise a front part 1102, an inner protrusion 1104, an outer protrusion 1106, and a plurality of second coupling members 1108.

[0159] The front part 1102, which may be arranged to be in contact with the lateral side of the display unit 900, may cover the space between the lateral side of the liquid crystal display panel 320 and a bending part 603, and also may cover the entire sides of the bending part 603, to thereby form the edge of the display unit 900.

[0160] The inner protrusion 1104, which may vertically protrude from one end of the front part 1102, may be inserted into the space between the lateral side of the liquid crystal display panel 320 and the inner sidewall 604 of the set cover 600, to thereby seal the space between the lateral side of the liquid crystal display panel 320 and the bending part 603.

[0161] The outer protrusion 1106, which may vertically protrude from the other end of the front part 1102, may cover the outer sides of the set sidewall 602.

[0162] The set sidewall 602, bending part 603, and inner sidewall 604 may be inserted into the \cap -shaped space prepared between the inner protrusion 1104 and the outer protrusion 1106.

[0163] The plurality of second coupling members 1108 may be provided at fixed intervals, wherein the plurality of second coupling members 1108 may protrude from the outer surface of the inner protrusion 1104 toward the guide frame 800. Each of the plural second coupling members 1108 may include a slant portion which is provided for a smooth connection to the guide frame 800; and a stepped portion which may be coupled to the stepped surface of the first coupling member 830 in the guide frame 800.

[0164] In the display apparatus 20 according to the tenth embodiment of the present invention, the structures provided at the lateral side of the liquid crystal display panel 320 may be covered by the edge frame 1100 connected to the guide frame 800, to thereby prevent the foreign matters from coming into the inside of the display apparatus. This provides the same effects as those of the aforementioned display apparatus according to the seventh embodiment of the present invention.

[0165] FIG. 20 illustrates a display apparatus according to an eleventh exemplary embodiment of the present invention.

[0166] Referring to FIG. 20, the display apparatus 20 according to the eleventh embodiment of the present invention may include a set cover 600, a support cover 700, a guide frame 800, and a display unit 900. Except that the support cover 700 and the guide frame 80 may be connected to each other, the display apparatus 20 according to the eleventh embodiment of the present invention may be identical in structure to the display apparatus according to the seventh or eighth embodiment of the present invention shown in FIGS. 15 to 17, whereby a detailed explanation for the same parts will be omitted.

[0167] The support cover 700, which may be received in a set plate of the set cover 600, may support the guide frame 800 and the display unit 900. For this, the support cover 700 may comprise a support plate which may be placed onto the set plate of the set cover 600; a support sidewall which may be vertically curved from the support plate; and a plurality of second coupling members 710 which may be hollowly formed at fixed intervals along the support sidewall. Preferably, the support cover 700 may be formed of the metal material so as to smoothly dissipate heat generated in the display unit 900. The support cover 700 may be connected to the set plate of the set cover 600 through the use of an adhesive member (for example, double-sided tape) or a coupling member (for example, screw). Preferably, the support cover 700 is connected to the set plate of the set cover 600 through the use of a coupling member.

[0168] The guide frame 800, which may be placed onto the support sidewall of the support cover 700, supports the display unit 900; and the guide frame 800 may be connected to the support sidewall of the support cover 700. For this, the guide frame 800 may be formed in a rectangular band, which comprises a guide sidewall 802, a supporter 804, and a plurality of first coupling members 830.

[0169] The guide sidewall 802 facing toward the set sidewall 602 may be formed in parallel to the set sidewall 602, and the guide sidewall 802 may be inserted between the support sidewall of the support cover 700 and the set sidewall 602.

[0170] The supporter **804** may be curved from an upper end of the guide sidewall **802** so that the supporter **804** may be placed onto the support sidewall of the support cover **700**, to thereby support the display unit **900**.

[0171] The plurality of first coupling members **830** may be formed in the guide sidewall **802**, and are connected to the second coupling member **710** of the support cover **700**. For this, the plurality of first coupling members **830** may protrude from the outer surface of the guide sidewall **802**, wherein each of the plural first coupling members **830** may include a stepped surface, and a slant surface which may extend from the stepped surface while being inclined by a predetermined angle.

[0172] According as each of the plural first coupling members **830** may be inserted into and coupled to each of the plural second coupling members **710**, the support cover **700** and the guide frame **800** may be connected to each other.

[0173] In the display apparatus **20** according to the eleventh embodiment of the present invention, the plurality of first coupling members **830** may be formed in the protrusion type along the guide sidewall **802**, and the plurality of second coupling members **710** may be formed in the groove type along the support sidewall, but not necessarily. The first and second coupling members **830** and **710** may be formed in various shapes for their coupling. For example, the plurality of first coupling members **810** may be formed in the shape of groove or hole along the guide sidewall **802**; and the plurality of second coupling members **710** may be formed in the shape of a protrusion along the support sidewall.

[0174] The display apparatus **20** according to the eleventh embodiment of the present invention may further comprise the sealing member (not shown) for sealing a gap (not shown) between a lateral side of a liquid crystal display panel **320** and the set sidewall **602**. At this time, the sealing member may be formed in the ring shape, pin shape, or film type shown in FIG. 4, 5, or 7.

[0175] The display apparatus **20** according to the eleventh embodiment of the present invention may provide the same effects as those of the display apparatus according to the seventh embodiment of the present invention.

[0176] For the aforementioned explanation, the display apparatus **10** shown in FIGS. 2 to 13 may be used for a notebook computer, and the display apparatus **20** shown in FIGS. 15 to 20 may be used for a monitor or television, but not necessarily. That is, the display apparatus **10** shown in FIGS. 2 to 13 may be used for a monitor, television, or mobile device, and the display apparatus **20** shown in FIGS. 15 to 20 may be used for a notebook computer or mobile device.

[0177] As mentioned above, the guide frame for supporting the display unit may be connected to the set cover, so that it is possible to decrease the total thickness of the device by innovatively removing the related art lower and upper cases, and the front cover of the manufactured device.

[0178] In addition, the edge width of the display unit may be decreased and the step coverage of the edge portion is minimized, to thereby manufacture the display apparatus having the novel design with the improved aesthetic exterior appearance.

[0179] It will be apparent to those skilled in the art that various modifications and variations can be made in the present invention without departing from the spirit or scope of the inventions. Thus, it is intended that the present

invention covers the modifications and variations of this invention provided they come within the scope of the appended claims and their equivalents.

1-25. (canceled)

26. A display apparatus comprising:

a set cover exposed to an external side of the display apparatus and forming a storage space, the set cover including a set plate and a set sidewall curved perpendicular to the set plate;

a guide frame connected to the set cover and disposed in the storage space; and

a display panel placed on the guide frame, wherein a top edge of the display panel is exposed externally to the display apparatus,

wherein the guide frame comprises:

a guide sidewall connected to the set cover; and

a supporter for supporting the display panel, wherein the supporter protrudes from the guide sidewall, r

wherein an upper surface of the guide sidewall is exposed to the external side of the display apparatus to cover a lateral side of the display panel, and the upper surface of the guide sidewall forms an edge of the display panel, and

wherein an upper outer surface of the guide sidewall and an outer surface of the set sidewall are exposed to the external side of the display apparatus.

27. The display apparatus according to claim 26, wherein the guide frame further comprises a set sidewall insertion groove hollowly formed in a lower outer surface of the guide sidewall and not in the upper outer surface of the guide sidewall,

wherein the set sidewall is inserted into the set sidewall insertion groove of the guide frame.

28. The display apparatus according to claim 27, wherein the guide frame further comprises a first coupling member in the set sidewall insertion groove,

wherein the set cover further comprises a second coupling member in the set sidewall, and

wherein the second coupling member of the set sidewall is coupled to the first coupling member of the guide frame.

29. The display apparatus according to claim 26, further comprising a sealing member sealing a gap between the lateral side of the display panel and the guide sidewall of the guide frame.

30. The display apparatus according to claim 29, wherein the sealing member is formed in a ring shape.

31. The display apparatus according to claim 29, wherein the sealing member is inserted into the gap between the lateral side of the display panel and the guide sidewall of the guide frame.

32. The display apparatus according to claim 29, wherein the sealing member comprises:

a head which covers the gap between the lateral side of the display panel and the upper surface of the guide sidewall; and

a head supporter which is inserted into the gap between the lateral side of the display panel and the guide sidewall of the guide frame.

33. The display apparatus according to claim 29, wherein the sealing member comprises:

a head which covers the gap between the lateral side of the display panel and the upper surface of the guide sidewall; and

a head supporter which is formed as one body with the upper surface of the guide sidewall.

34. The display apparatus according to claim **29**, wherein the guide frame further comprises a sealing member adhesion groove formed in the upper surface of the guide sidewall, and

wherein the sealing member is adhered to the top edge of the display panel and the sealing member adhesion groove so as to cover the gap between the lateral side of the display panel and the guide sidewall of the guide frame.

35. The display apparatus according to claim **34**, wherein the sealing member is formed as a film.

36. The display apparatus according to claim **26**, wherein the set cover further comprises a separation hole formed in the second coupling member or formed in the set sidewall to be adjacent to the second coupling member, and

wherein a separation pin is inserted into the separation hole so as to separate the first coupling member from the second coupling member by forcibly pushing the guide sidewall.

37. The display apparatus according to claim **36**, further comprising a sealing cap sealing the separation hole.

38. The display apparatus according to claim **26**, wherein the guide frame is black.

39. The display apparatus according to claim **26**, wherein the supporter comprises:

a first part protruding from the guide sidewall in an opposite direction to the set sidewall;

a curved part curved from the first part toward the set plate; and

a second part curved from the curved part and placed onto the set plate.

40. The display apparatus according to claim **37**, further comprising a backlight unit received in the storage space and placed on the second part,

wherein the display panel is placed on the first part, and wherein the display panel displays images by modulating transmittance of light emitted from the backlight unit.

* * * * *

专利名称(译)	显示装置		
公开(公告)号	US20180011368A1	公开(公告)日	2018-01-11
申请号	US15/710153	申请日	2017-09-20
[标]申请(专利权)人(译)	乐金显示有限公司		
申请(专利权)人(译)	LG DISPLAY CO. , LTD.		
当前申请(专利权)人(译)	LG DISPLAY CO. , LTD.		
[标]发明人	SON NAM DO YOU SONG RYOL BAEK KYEONG TAK KIM SEONG ROK KIM DONG YONG JEAN KI NAM		
发明人	SON, NAM DO YOU, SONG RYOL BAEK, KYEONG TAK KIM, SEONG ROK KIM, DONG YONG JEAN, KI NAM		
IPC分类号	G02F1/1333		
CPC分类号	G02F2201/465 G02F2001/133322 G02F1/133308		
优先权	1020100039024 2010-04-27 KR		
其他公开文献	US10082693		
外部链接	Espacenet USPTO		

摘要(译)

本发明公开了一种显示装置，该显示装置通过创新地移除壳体和设置的盖子的一些部分来促进最小化的厚度，其被认为是显示装置的必不可少的结构，并且同时通过新颖的设计促进了显示装置的良好美学外观。显示装置包括外部暴露的设置盖，以具有存储空间；支撑盖放置在存储空间上并形成具有支撑空间；背光单元容纳在支撑空间中；引导框架，在由支撑盖支撑的同时连接到支撑盖，并容纳在存储空间中；液晶显示面板放置在引导框架上，液晶显示面板通过调节从背光单元发出的光的透射率来显示图像。

