



US009436034B2

(12) **United States Patent**
Kim et al.

(10) **Patent No.:** **US 9,436,034 B2**
(45) **Date of Patent:** **Sep. 6, 2016**

(54) **DISPLAY DEVICE HAVING A FIRST POLARIZATION LAYER COMPRISING AN ISOTROPIC MACROMOLECULAR MATERIAL AND A SECOND POLARIZER LAYER COMPRISING A MACROMOLECULAR MATERIAL HAVING A POSITIVE BIREFRINGENCE, THE FIRST AND SECOND POLARIZERS LAYERS STACKED ON EACH OTHER**

(71) Applicant: **Samsung Display Co., Ltd.**, Yongin, Gyeonggi-do (KR)

(72) Inventors: **Sang-Jae Kim**, Seongnam-si (KR); **Boo-Kan Ki**, Yongin-si (KR); **Ji-Hye Kim**, Hwaseong-si (KR); **Hee-Wook Do**, Cheonan-si (KR); **Jae-Won Park**, Seoul (KR); **Duck-Jong Suh**, Seoul (KR); **Jung-Hun Lee**, Seoul (KR); **Hyoung-Joo Lee**, Gongju-si (KR); **Seon-Ah Cho**, Busan (KR); **Hyo-Sung Hong**, Suwon-si (KR)

(73) Assignee: **SAMSUNG DISPLAY CO., LTD.**, Yongin, Gyeonggi-Do (KR)

(*) Notice: Subject to any disclaimer, the term of this patent is extended or adjusted under 35 U.S.C. 154(b) by 226 days.

(21) Appl. No.: **14/017,672**

(22) Filed: **Sep. 4, 2013**

(65) **Prior Publication Data**
US 2014/0146273 A1 May 29, 2014

(30) **Foreign Application Priority Data**
Nov. 23, 2012 (KR) 10-2012-0133365

(51) **Int. Cl.**
G02F 1/1335 (2006.01)

(52) **U.S. Cl.**
CPC ... **G02F 1/133536** (2013.01); **G02F 1/133524** (2013.01); **G02F 2001/133531** (2013.01)

(58) **Field of Classification Search**
CPC G02F 1/133536; G02F 2001/133631; G02F 2001/133545; G02F 1/133512; G02F 1/133555; G02F 2001/134345; G02F 1/133524; G02B 27/26; G02B 5/3083; G02B 6/0033; G02B 6/0035; G02B 6/0055; H04N 13/0434; G09G 3/003; G01J 3/02; G01J 3/0283; G01J 3/0224; G01N 21/65; H01L 27/322; H01L 51/5281; B41M 5/395
See application file for complete search history.

(56) **References Cited**
U.S. PATENT DOCUMENTS

6,480,248 B1 11/2002 Lee et al.
7,817,106 B2 10/2010 Fukushima et al.
(Continued)

FOREIGN PATENT DOCUMENTS

JP 2008090173 4/2008
JP 2011232681 11/2011
(Continued)

Primary Examiner — Huyen Ngo
(74) *Attorney, Agent, or Firm* — F. Chau & Associates, LLC

(57) **ABSTRACT**
A display panel includes a first substrate, a second substrate, a liquid crystal layer, a first polarizer, a second polarizer and a viewing angle control layer. The second substrate faces the first substrate. A liquid crystal layer is disposed between the first substrate and the second substrate. A first polarizer is disposed on a lower surface of the first substrate and includes a first polarizing layer and a second polarizing layer stacked on each other. A second polarizer is disposed on an upper surface of the second substrate. A viewing angle control layer is disposed on the first polarizer and is configured to control a viewing angle of a column direction of the display panel.

24 Claims, 5 Drawing Sheets

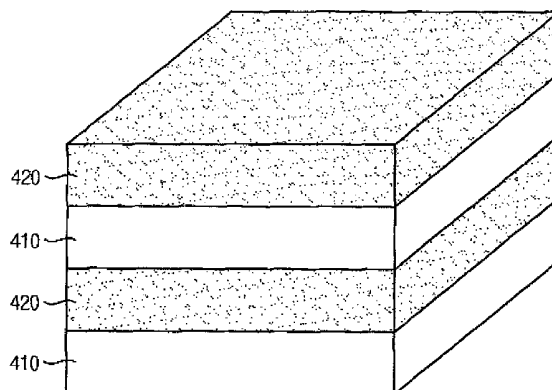

(56)

References Cited

U.S. PATENT DOCUMENTS

7,932,975 B2 4/2011 Sakai et al.
7,936,422 B2 5/2011 Adachi et al.
8,189,147 B2 5/2012 Sakai et al.
2005/0213003 A1* 9/2005 Kaneko 349/114
2010/0002171 A1* 1/2010 Yoshimi 349/96
2010/0073604 A1* 3/2010 Okuyama et al. 349/75
2011/0102690 A1* 5/2011 Kikuchi et al. 349/15
2011/0249333 A1* 10/2011 Kuriyama et al. 359/489.07
2012/0154463 A1* 6/2012 Hur et al. 345/691

2012/0162763 A1* 6/2012 Son G02B 27/2214
359/463
2012/0287504 A1* 11/2012 Jang G02B 27/26
359/463
2013/0293802 A1* 11/2013 Chae 349/58

FOREIGN PATENT DOCUMENTS

KR 1020070111037 11/2007
KR 1020110024079 3/2011

* cited by examiner

FIG. 1

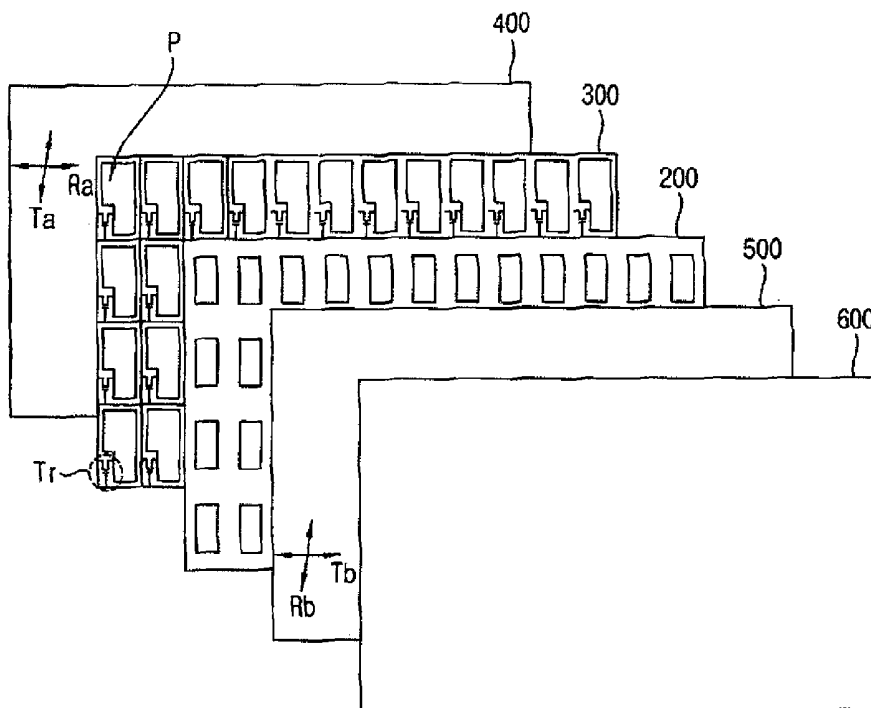

FIG. 2

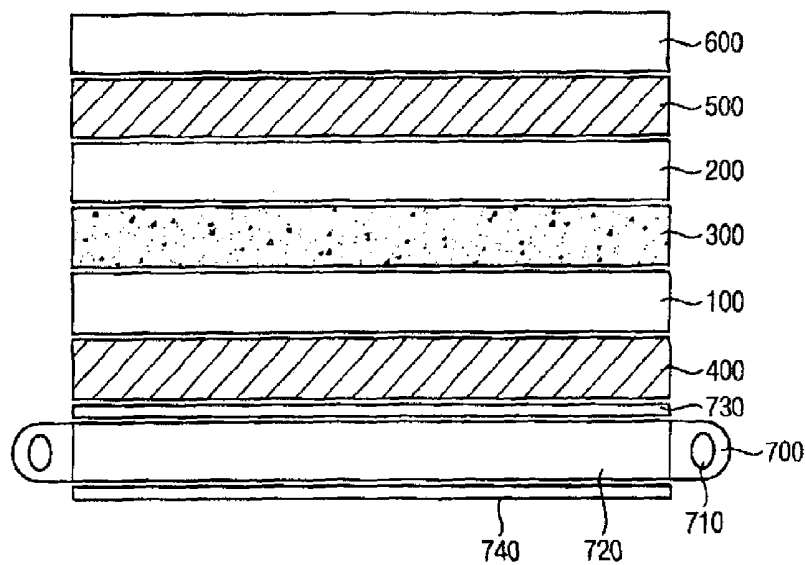

FIG. 3

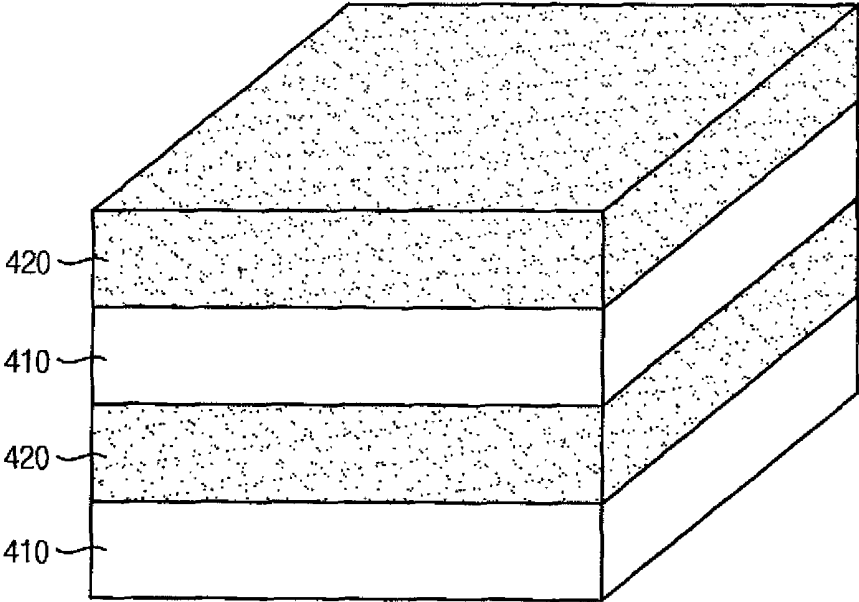

FIG. 4

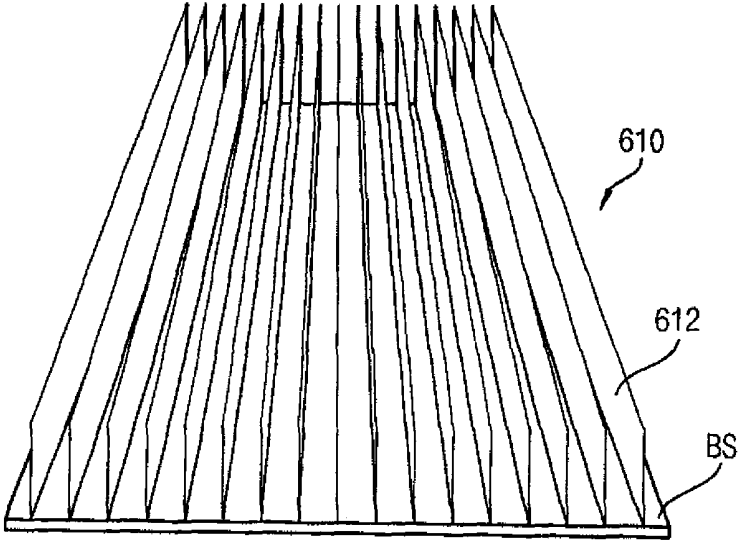

FIG. 5

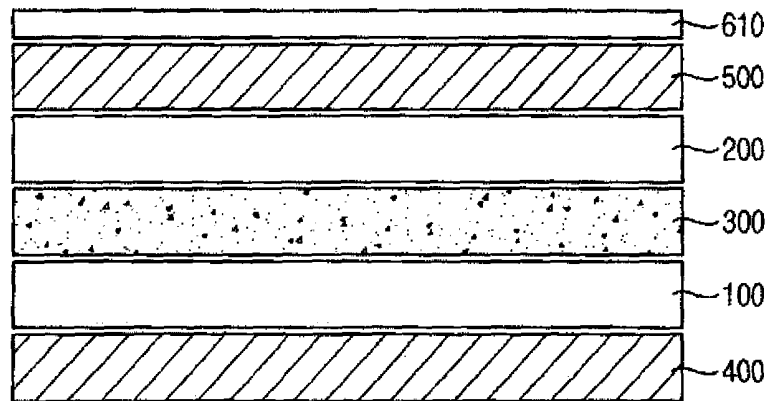

FIG. 6

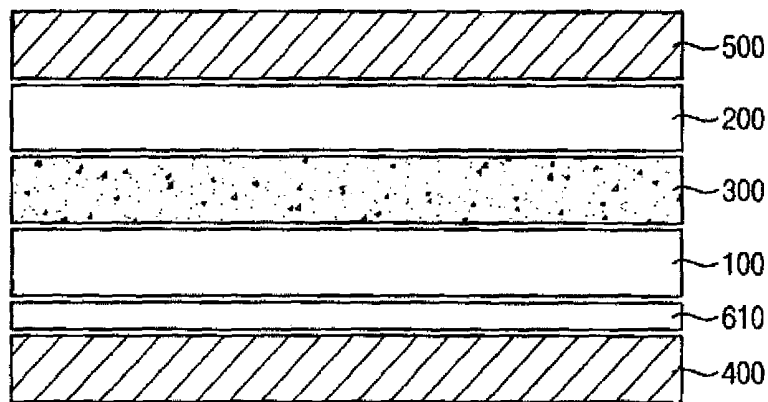

FIG. 7

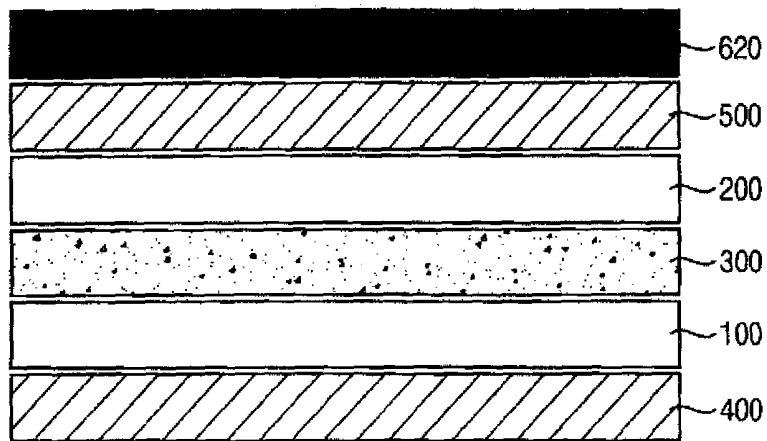

FIG. 8

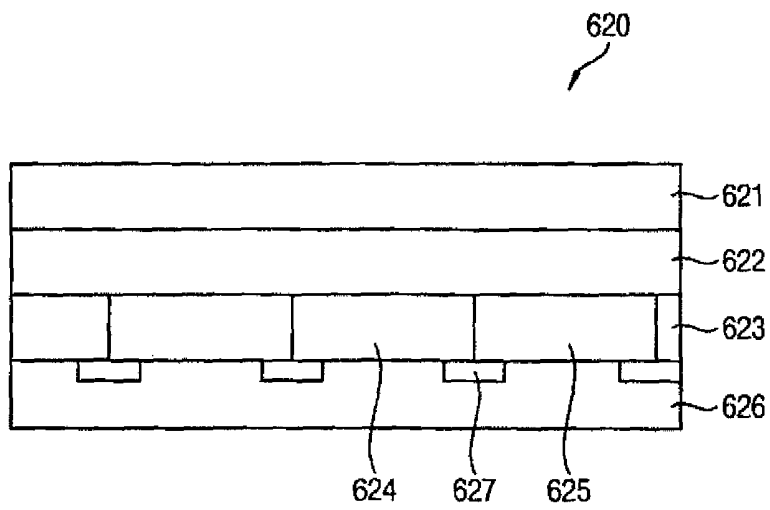

FIG. 9

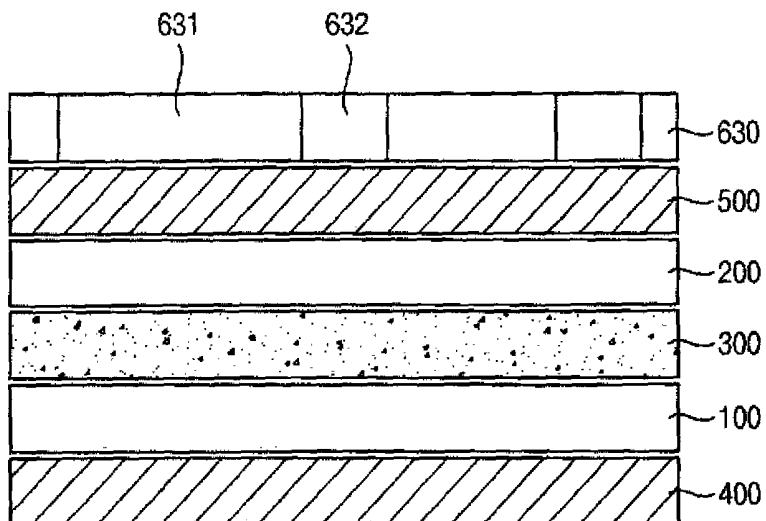
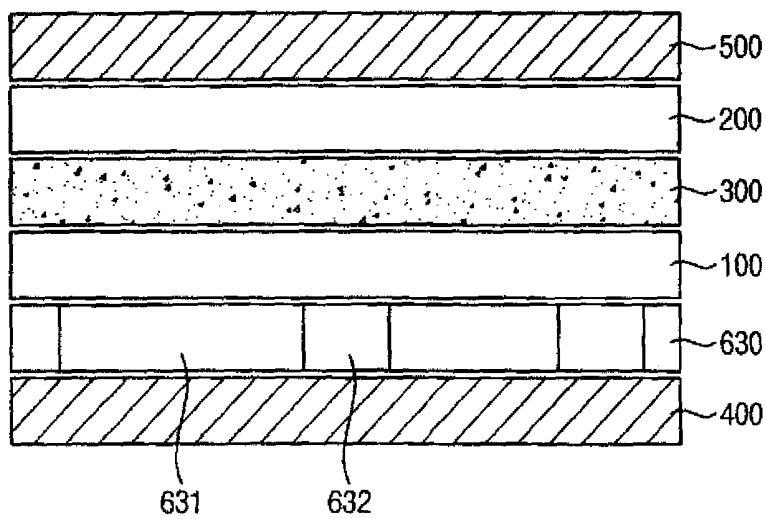

FIG. 10



**DISPLAY DEVICE HAVING A FIRST
POLARIZATION LAYER COMPRISING AN
ISOTROPIC MACROMOLECULAR
MATERIAL AND A SECOND POLARIZER
LAYER COMPRISING A
MACROMOLECULAR MATERIAL HAVING
A POSITIVE BIREFRINGENCE, THE FIRST
AND SECOND POLARIZERS LAYERS
STACKED ON EACH OTHER**

This application claims priority to Korean Patent Application No. 10-2012-0133365, filed on Nov. 23, 2012, the disclosure of which is hereby incorporated by reference herein in its entirety.

TECHNICAL FIELD

Example embodiments relate to a display panel and a display device having the same. More particularly, example embodiments relate to a display panel including a viewing angle control layer and a reflective polarizer, and a display device having the same.

DISCUSSION OF THE RELATED ART

A Liquid Crystal Display LCD device is one type of flat display device. The LCD device is a display device that applies voltages to specific molecules of liquid crystal to convert arrangements of the molecules and change an optical property of the liquid crystal cell such as, for example, a birefringence, an optical activity, a dichroism, a light scattering, etc. to display an image.

Generally, the display panel includes a liquid crystal layer disposed between two substrates. A liquid crystal is, for example, injected between two substrates, to thereby form the liquid crystal layer. Two polarizers may be disposed on outer surfaces of two substrates. For example, a reflection polarizer and an absorption polarizer may pass or absorb light of a specific polarization, to thereby display an image. The reflection polarizer may pass only light of a specific polarization and reflect light of another polarization. The absorption polarizer may pass only light of a specific polarization and absorb light of another polarization. However, because the display panel includes different type of polarizers, the brightness may be decreased and the manufacturing costs associated therewith may be increased.

Additionally, an optical sheet may be used to increase the brightness of a display device. For example, the optical sheet may include a dual brightness enhancement film (DBEF). DBEF may recycle a polarization which is reflected by the reflection polarizer. Therefore, a luminance efficiency of the display device may be increased by a polarization recycling.

However, in consideration of the cost of DBEF, new reflection polarizers have been developed. The new reflection polarizer may include, for example, a cholesteric liquid crystal (CLC), a wire grid polarizer (WGP) or a birefringence optical fiber.

When the display device includes only the reflection polarizer, a reddish phenomenon may occur in a vertical direction, such as, for example, a column direction of the display panel.

SUMMARY

Example embodiments provide a display panel capable of increasing the brightness and preventing a reddish phenomenon in a column direction of the display panel.

Example embodiments also provide a display device including the above-mentioned display panel.

In accordance with an example embodiment, a display panel includes a first substrate, a second substrate, a liquid crystal layer, a first polarizer, a second polarizer and a viewing angle control layer. The second substrate faces the first substrate. A liquid crystal layer is disposed between the first substrate and the second substrate. A first polarizer is disposed on a lower surface of the first substrate and includes a first polarizing layer and a second polarizing layer stacked on each other. A second polarizer is disposed on an upper surface of the second substrate. A viewing angle control layer is disposed on the first polarizer and is configured to control a viewing angle of a column direction of the display panel.

In an example embodiment, the viewing angle control layer may be disposed on the upper surface of the second polarizer.

In an example embodiment, the viewing angle control layer may be disposed between the first substrate and the first polarizer.

In an example embodiment, the first polarizer may be a reflection polarizer, and the second polarizer is an absorption polarizer.

In an example embodiment, the first polarizer and the second polarizer may be a reflection polarizer.

In an example embodiment, an absorption axis of the second polarizer may be parallel to a reflection axis of the first polarizer.

In an example embodiment, the viewing angle control layer may include a viewing angle control film. The viewing angle control film may include a base sheet and a protrusion portion protruding from an upper surface of the base sheet and extending in a direction.

In an example embodiment, an absorption axis of the viewing angle control layer may be parallel to a reflection axis of the first polarizer.

In an example embodiment, the viewing angle control layer may include a pattern retarder.

In an example embodiment, the pattern retarder may include a base layer, a pattern retarding layer and an adhesive layer. The base layer may have a birefringence. The pattern retarding layer may be disposed on a lower surface of the base layer and may include patterns having a different optical axis from each other. The adhesive layer may be disposed on a lower surface of the pattern retarding layer.

In an example embodiment, the pattern retarding layer may include a first retarder, a second retarder and a black matrix. The first retarder may be configured to convert a first light to a first polarization. The second retarder may be configured to convert a second light to a second polarization. The black matrix may be disposed on lower surfaces of the first retarder and the second retarder to cover boundary portions between the first retarder and the second retarder.

In an example embodiment, the black matrix may be parallel to a reflection axis of the first polarizer.

In an example embodiment, the viewing angle control layer may include a parallax barrier layer. The parallax barrier layer may include a plurality of parallax barriers and a wire grid polarizer. The wire grid polarizer may be disposed between the plurality of parallax barriers.

In an example embodiment, an absorption axis of the parallax barrier may be parallel to a reflection axis of the first polarizer.

In accordance with example embodiment, a display device includes a display panel and a backlight assembly. The display panel includes a first substrate, a second sub-

strate, a liquid crystal layer, a first polarizer, a second polarizer and a viewing angle control layer. The second substrate faces the first substrate. The liquid crystal layer is disposed between the first substrate and the second substrate. The first polarizer is disposed on a lower surface of the first substrate and includes a first polarizing layer and a second polarizing layer stacked on each other. The second polarizer is disposed on an upper surface of the second substrate. The viewing angle control layer is disposed on the first polarizer and is configured to control a viewing angle of a column direction of the display panel. The backlight assembly is configured to provide a light to the display panel.

In an example embodiment, the viewing angle control layer may be disposed on an upper surface of the second polarizer.

In an example embodiment, the viewing angle control layer may include a viewing angle control film. The viewing angle control film may include a base sheet and a protrusion portion. The protrusion portion may be protruding from an upper surface of the base sheet and may be extending in a direction.

In an example embodiment, the viewing angle control layer may include a pattern retarder. The pattern retarder may include a base layer, a pattern retarding layer and an adhesive layer. The base layer may have a birefringence. The pattern retarding layer may be disposed on a lower surface of the base layer and may include patterns having a different optical axis from each other. The adhesive layer may be disposed on a lower surface of the pattern retarding layer.

In an example embodiment, the viewing angle control layer may include a parallax barrier layer and a wire grid polarizer. The parallax barrier layer may include a plurality of parallax barriers. The wire grid polarizer may be disposed between the plurality of parallax barriers.

In accordance with an example embodiment, a display device which includes a display panel and a backlight assembly is provided. The display panel includes a first substrate, a second substrate facing the first substrate, a liquid crystal layer disposed between the first substrate and the second substrate, a first polarizer disposed on a lower surface of the first substrate and including a first polarizing layer and a second polarizing layer stacked on each other, a second polarizer disposed on an upper surface of the second substrate, and a viewing angle control layer disposed on the first polarizer and configured to control a viewing angle of a column direction of the display panel, and an optical sheet disposed on a lower surface of the first polarizer.

In addition, the display device further includes a backlight assembly disposed on a lower surface of the optical sheet and configured to provide a light to the display panel.

In accordance with example embodiments of the present invention, a display panel and a display device having the same, a reflection polarizer may be applied as a first polarizer of the display panel. Thus, optical materials may be reduced and the brightness of the display panel may increase. Accordingly, a film for increasing the brightness may not be needed, so that manufacturing costs may be decreased.

Furthermore, the display panel includes a viewing angle control layer. The viewing angle control layer includes a viewing angle control film, a pattern retarder or a parallax barrier layer. When the reflection polarizer is applied as a first polarizer, a reddish phenomenon may be prevented.

Accordingly, a viewing angle at a column direction of the display panel may be decreased by including the viewing angle control layer, so that the reddish phenomenon may be prevented.

BRIEF DESCRIPTION OF THE DRAWINGS

Example embodiments of the invention can be understood in more detail from the following detailed description taken in conjunction with the accompanying drawings, in which:

FIG. 1 is a plan view illustrating a display panel in accordance with an example embodiment;

FIG. 2 is a cross-sectional view illustrating a display device including the display panel of FIG. 1;

FIG. 3 is a perspective view illustrating a reflection polarizer in the display panel of FIG. 1;

FIG. 4 is a perspective view illustrating a viewing angle control film in accordance with an example embodiment;

FIG. 5 is a cross-sectional view illustrating a display panel in accordance with an example embodiment including the viewing angle control film in the FIG. 4;

FIG. 6 is a cross-sectional view illustrating a display panel in accordance with an example embodiment including the viewing angle control film in the FIG. 4;

FIG. 7 is a cross-sectional view illustrating a display panel in accordance with an example embodiment including a pattern retarder;

FIG. 8 is a cross-sectional view illustrating the pattern retarder in the display panel of FIG. 7;

FIG. 9 is a cross-sectional view illustrating a display panel in accordance with an example embodiment including a parallax barrier layer; and

FIG. 10 is a cross-sectional view illustrating a display panel in accordance with an example embodiment including a parallax barrier layer.

DETAILED DESCRIPTION OF EXAMPLE EMBODIMENTS OF THE INVENTION

Hereinafter, example embodiments will be explained in detail with reference to the accompanying drawings.

In the drawings, the thickness of layers, films, panels, regions, etc., may be exaggerated for clarity. Like reference numerals designate like elements throughout the specification. It will be understood that when an element such as a layer, film, region, or substrate is referred to as being "on" another element, it can be directly on the other element or intervening elements may also be present.

As used herein, the singular forms, "a", "an", and "the" are intended to include plural forms as well, unless the context clearly indicates otherwise.

FIG. 1 is a plan view illustrating a display panel in accordance with an example embodiment. FIG. 2 is a cross-sectional view illustrating a display device including the display panel of FIG. 1. FIG. 3 is a perspective view illustrating a reflection polarizer in the display panel of FIG. 1.

Referring to FIGS. 1 to 3, a display device includes, for example, a first substrate 100, a second substrate 200, a liquid crystal layer 300, a first polarizer 400, a second polarizer 500, a viewing angle control layer 600, a backlight assembly 700 and an optical sheet 730.

The first substrate 100 and the second substrate 200 may be, for example, a transparent insulation substrate. For example, the transparent insulation substrate may include a glass substrate, a quartz substrate, or a plastic substrate, etc. Further, in an example embodiment, the transparent insula-

tion substrate may be, for example, a flexible substrate. Suitable materials for the flexible substrate include, for example, polyethersulfone (PES), polyethylenenaphthalate (PEN), polyethylene (PE), polyimide (PI), polyvinyl chloride (PVC), polyethylene terephthalate (PET), or a combination thereof.

The first substrate **100** may be, for example, a thin film transistor substrate including thin film transistors Tr. The thin film transistor Tr substrate includes, for example, a plurality of transistors Tr, which are formed in a matrix shape. The first substrate **100** may include a plurality of gate lines GL and a plurality of data lines DL which are connected to the thin film transistors Tr respectively.

The first substrate **100** may further include a plurality of pixel electrodes PE which are connected to the thin film transistors Tr respectively. The pixel electrodes PE may include, for example, a transparent conductive oxide material, such as indium tin oxide (ITO), indium zinc oxide (IZO), aluminum doped ZnO (AZO), cadmium zinc oxide (CZO), indium gallium zinc oxide (IGZO), or a combination thereof.

The second substrate **200** may include, for example, a common electrode CE which faces to the pixel electrode. Alternatively, the common electrode CE may be disposed on, for example, the first substrate **100**. The common electrode CE may include, for example, a transparent conductive oxide material, such as indium tin oxide (ITO), indium zinc oxide (IZO), aluminum doped ZnO (AZO), cadmium zinc oxide (CZO), indium gallium zinc oxide (IGZO), or a combination thereof.

The second substrate **200** may be, for example, a color filter substrate having color filters. The color filter substrate converts a light which is incident from the backlight assembly **700** to a desired color. For example, the second substrate **200** may include a first color filter, a second color filter and a third color filter. The second substrate **200** may further include, for example, a black matrix BM which is disposed between the first, second and third color filters. For example, the first color filter may be a red color filter R. The second color filter may be, for example, a green color filter G. The third color filter may be, for example, a blue color filter B. Alternatively, the color filters may be disposed on, for example, the first substrate **100**.

The liquid crystal (LC) layer **300** may be disposed between the first substrate **100** and the second substrate **200**. The liquid crystal layer **300** may include, for example, liquid crystal molecules having an optical anisotropy. The liquid crystal molecule is driven by an electric field, so that the liquid crystal molecule transmits or blocks a light, to thereby display an image.

The first polarizer **400** may be disposed on, for example, a lower surface of the first substrate **100**. The backlight assembly **700** may be disposed on, for example, a lower surface of the first polarizer **400**. The optical sheet **730** may be disposed, for example, between the first polarizer **400** and the backlight assembly **700**.

The second polarizer **500** may be disposed on, for example, an upper surface of the second substrate **200**. The second polarizer **500** may be positioned, for example, adjacent to a viewer. The second polarizer **500** may include, for example, an adhesion layer (not illustrated) to be adhered to the second substrate **200**. The adhesion layer may include, for example, a pressure sensitivity adhesive. The adhesion layer may be formed, for example, in a film type. The adhesion layer is adhered to the second substrate **200** in response to an outer pressure.

The display panel according to an example embodiment may further include, for example, a viewing angle control layer **600** to decrease a viewing angle in a column direction of the display panel.

The viewing angle control layer **600** may be disposed, for example, on an upper surface of the second polarizer **500**. Alternatively, the viewing angle control layer **600** may be disposed, for example, between the first substrate **100** and the first polarizer **400**.

An absorption axis Tc (not illustrated) of the viewing angle control layer **600** may be, for example, perpendicular to the column direction of the display panel. That is, the absorption axis of the viewing angle control layer **600** may be, for example, parallel with the reflection axis Ra of the first polarizer **400** and the absorption axis Tb of the second polarizer **500**.

The viewing angle control layer **600** may include a viewing angle control film (See FIGS. 4 and 5), a pattern retarder (See FIGS. 7 and 8) or a parallax barrier layer (See FIG. 9).

The backlight assembly **700** may provide a light to the display panel. The backlight assembly **700** may be disposed, for example, under the display panel.

The backlight assembly **700** may include, for example, a light guide plate **720**, a reflection plate **740** and a light source **710** which generates a light.

The backlight assembly **700** may include, for example, at least one light source **710** disposed in a side of the backlight assembly **700**. The light source **710** may generate a light to the light guide plate **720**.

Examples of the light source **710** may include but are not limited to a cold cathode fluorescent lamp (CCFL), an external electrode fluorescent lamp (EEFL), a flat fluorescent lamp (FFL), a light emitting diode (LED), an electro luminescence (EL), and hot cathode fluorescent lamp (HCFL). The light source **710** may be, for example, a point light source or a linear light source.

The light guide plate **720** may convert, for example, an incident light from the point light source or the linear light source into an outgoing light having a plane light source. That is, the light guide plate **720** converts a light path. Moreover, the light guide plate **720** may be formed of, for example, a resin based material such as at least one of a polymethylmethacrylate (PMMA), a polyethylene terephthalate (PET) resin, a polycarbonate (PC) resin, a cyclic olefin copolymer (COC) resin, and a polyethylene naphthalate (PEN) resin.

The reflection plate **740** may be disposed, for example, on a lower surface of the light guide plate **720**. The reflection plate **740** reflects a light which is emitted to the light guide plate **720**, to thereby increase luminance efficiency. For example, in an example embodiment, reflective plate **740** may be formed of a plastic such as polyethyleneterephthalate (PET) or polycarbonate (PC).

The optical sheet **730** may be disposed, for example, on an upper surface of the backlight assembly **700**. The optical sheet **730** may include, for example, a plurality of sheets. Examples of the optical sheet may be, for example, a protection sheet, a diffusion sheet, a prism sheet, etc. Alternatively, for example, in an example embodiment, the optical sheet **730** may be omitted.

Referring again to FIG. 3, the reflection polarizer may include, for example, a plurality of polarizing layers stacked on each other and having a different reflective index from each other. In the present embodiment, the reflection polarizer may include, for example, a first polarizing layer **410** and a second polarizing layer **420** stacked on each other. The

first polarizing layer **410** includes, for example, a birefringence material. The second polarizing layer **420** includes, for example, a material having a reflective index different from the birefringence material of the first polarizing layer **410**.

Furthermore, the second polarizing layer **420** of the reflection polarizer may include, for example, a macromolecular material having a positive birefringence. The first polarizing layer **410** of the reflection polarizer may include, for example, an isotropic macromolecular material. For example, a polyvinyl alcohol film may be stretched and dyed with iodine or dichroic dye to form the absorption polarizer. An axis of the absorption polarizer may be formed to be, for example, perpendicular to the stretched direction of the polyvinyl alcohol film.

The first polarizer **400** may include, for example, the reflection polarizer and the second polarizer **500** may include the absorption polarizer. Alternatively, both of the first polarizer **400** and the second polarizer **500** may include, for example, the reflection polarizer.

When the absorption polarizer and the reflection polarizer are used together, a reflection axis of the reflection polarizer may be, for example, parallel to an absorption axis of the absorption polarizer. When both of the first polarizer **400** and the second polarizer **500** include the reflection polarizer, a reflection axis of the first polarizer may be, for example, perpendicular to a reflection axis of the second polarizer.

The absorption axis Tb of the second polarizer **500** may be, for example, perpendicular to the absorption axis Ta of the first polarizer **400**. A reflection axis Rb of the second polarizer **500** may be, for example, parallel to an absorption axis Ta of the first polarizer **400**.

A light, which vibrates in a first direction and a second direction, may be incident from the backlight assembly **700** to the first polarizer **400**. A light, which vibrates in the first direction perpendicular to the reflection axis Ra of the first polarizer **400** including the reflection polarizer, may only pass through the first polarizer **400**. Thus, a light which vibrates in the second direction may be reflected by the first polarizer **400**.

The second polarizer **500** may be disposed, for example, on an upper surface of the second substrate **200**. The second polarizer **500** may include, for example, the absorption polarizer. A light, which passes through the first polarizer **400** and a liquid crystal layer **300** to which an electric field is applied, may be incident to the second polarizer **500**. A light, which vibrates in the second direction parallel to the absorption axis Tb of the second polarizer **500** including the absorption polarizer, may only pass through the second polarizer **500**.

The reflection polarizer may allow a light, which has a specific direction, to pass through and may reflect a light which has another direction. Thus, the reflection polarizer may linearly polarize a light emitted from the backlight assembly to about 100 percent. Accordingly, an optical loss in the absorption polarizer may be reduced and an amount of a light which passes through may be increased, to thereby increase the brightness of the display device.

The absorption polarizer passes light of a specific polarization and absorbs light of other polarizations. The reflection polarizer passes light of a specific polarization and reflects light of other polarizations. Accordingly, when both of the first polarizer **400** and the second polarizer **500** are used as the reflection polarizer, a luminance efficiency of the display device may be increased by using the reflected polarized light.

When the first polarizer **400** and the second polarizer **500** are used as the reflection polarizer, most polarized lights may pass through the display panel, so that the display panel may be glittered to deteriorate visibility. Alternatively, the display panel may be applicable to a billboard, which may tolerate a glittered display panel.

When a light, which passes through the first polarizer **400** and the liquid crystal layer **300** to which an electric field is applied, is incident to the second polarizer **500**, a light vibrating only in the second direction may pass through the first polarizer **400**. The second direction is perpendicular to a reflection axis of the second polarizer **500** including the reflection polarizer. Another light, which vibrates in the first direction, is reflected by the second polarizer **500**.

Although it is not illustrated in the figures, the first polarizer **400** and the second polarizer **500** may further include, for example, a phase difference layer, a protection film, etc. The first polarizer **400** and the second polarizer **500** may include, for example, a polymer material. Examples of the polymer material may include but are not limited to polycarbonate, polystyrene, polyvinyl alcohol, poly methyl methacrylate, polypropylene, polyolefine, polyacrylate, polyamide, etc.

In the display panel, when the first polarizer **400** includes the reflection polarizer, a reddish phenomenon may occur along a column direction of the display panel, which is a vertical direction of the display panel.

The reddish phenomenon may be prevented by decreasing a viewing angle in a column direction of the display panel. As the viewing angle in the column direction is decreased, the reddish phenomenon may disappear.

FIG. 4 is a perspective view illustrating a viewing angle control film in accordance with an example embodiment. FIG. 5 is a cross-sectional view illustrating a display panel in accordance with an example embodiment including the viewing angle control film in the FIG. 4. FIG. 6 is a cross-sectional view illustrating a display panel in accordance with an example embodiment including the viewing angle control film in FIG. 4.

Referring to the FIGS. 4 to 6, the viewing angle control film **610** may partially block a light from the display panel such that an image of the display panel may be observed at a front or at a specific viewing angle.

A viewing angle control layer **600** of the display panel may include, for example, a viewing angle control film **610**.

The viewing angle control film **610** may include, for example, a base sheet BS and a protrusion portion **612** protruding from an upper surface of the base sheet BS and extending in a direction. The protrusion portion **612** may partially pass a light or partially interfere with the light, to thereby decrease a viewing angle. The protrusion portion **612** may extend, for example, in a first direction on the base sheet BS. The first direction is, for example, parallel with the absorption axis of the viewing angle control film **610**.

The protrusion portion **612** may include, for example, a light reflecting material and a light absorbing material. The light reflecting material of the protrusion portion includes, for example, titanium dioxide, zinc oxide, zinc sulfide, zinc phosphate, calcium carbonate, alumina, silica, antimony oxide, barium sulfide, lytopene (co-precipitate of barium sulfide and zinc oxide), calcined kaolin, lead carbonate, magnesium oxide, etc. These may be used alone or in a mixture thereof. The light absorbing material of the protrusion portion **612** includes, for example, carbon black, spinel black, rutile black, iron black, etc. These may be used alone or in a mixture thereof.

For example, the protrusion portion **612** of the viewing angle control film **610** extends in a column direction of the display panel. That is, the protrusion portion **612** may extend, for example, perpendicular to the reflection axis Ra of the first polarizer **400**, to thereby decrease the viewing angle. Accordingly, an image of the display panel may be not observed well to a viewer outside the viewing angle range, so that the security of the display device may be increased.

In case that the protrusion portion **612** of the viewing angle control film **610** extends in the row direction of the display panel, a viewing angle in a row direction of the display panel may be decreased. However, a viewing angle in the column direction may not be decreased. Accordingly, when a reflection axis Ra of the first polarizer **400** rotates about 90 degrees, a viewing angle in a column direction may be decreased, to thereby prevent a reddish phenomenon.

Alternatively, when the protrusion portion **612** of the viewing angle control film **610** extends in a row direction of the display panel, a viewing angle in a column direction of the display panel may be decreased without rotating an reflection axis Ra of the first polarizer **400** about 90 degrees.

As mentioned above, an absorption axis of the viewing angle control layer **600** may be controlled to extend in a column direction. That is, the protrusion portion **612** of the viewing angle control film **610** may extend in a row direction. Therefore, the viewing angle in a column direction may be decreased, so that a reddish phenomenon may be prevented.

The absorption axis Tb of the second polarizer **500** may be parallel to the reflection axis Ra of the first polarizer **400**.

Accordingly, the absorption axis of the viewing angle control film **610** is parallel to the reflection axis Ra, to thereby prevent the reddish phenomenon.

In the present example embodiment of FIGS. **4** and **5**, the viewing angle control film **610** is disposed on the second polarizer **500**.

Alternatively, in an example embodiment, as shown in FIG. **6**, the viewing angle control film **610** may be disposed between the first substrate **100** and the first polarizer **400**.

FIG. **7** is a cross-sectional view illustrating a display panel in accordance with an example embodiment including a pattern retarder. FIG. **8** is a cross-sectional view illustrating the pattern retarder in the display panel of FIG. **7**.

Referring to FIG. **7** and FIG. **8**, a viewing angle control layer **600** may include, for example, a pattern retarder **620**.

The pattern retarder **620** may include, for example, a surface treatment layer **621**, a base layer **622** having a birefringence, a pattern retarding layer **623** disposed on a lower surface of the base layer **622** and including patterns having a different optical axis from each other and an adhesive layer **626** disposed on a lower surface of the pattern retarding layer **623**.

The surface treatment layer **621** may be used to decrease a reflection by an external light. However, the surface treatment layer **621** may be omitted for simplicity.

The base layer **622** may include, for example, an organic macromolecule. A thickness of the base layer **622** may be controlled to obtain a desired retardation value. Examples of the organic macromolecule may include but are not limited to triacetin cellulose (TAC), cyclo olefin copolymer (COP), polyacrylate (PAC), polyetheretherketone (PEEK), polyvinylalcohol (PVA), etc.

The pattern retarding layer **623** may include, for example, a first retarder **624** converting a first light into a first polarization, a second retarder **625** converting a second light into a second polarization, and a black matrix (BM) **627** disposed on lower surfaces of the first retarder **624** and the

second retarder **625** to cover boundary portions between the first retarder **624** and the second retarder **625**.

The pattern retarder layer **623** may include, for example, the first retarder **624** and the second retarder **625**. The first retarder **624** and the second retarder **625** may be disposed, for example, alternately in a column direction of the display panel.

As illustrated in FIG. **7**, the adhesive layer **626** may be, for example, adhered to the second polarizer **500** of the display panel and the pattern retarder **620**. Therefore, the adhesive layer **626** may be disposed, for example, on an upper surface of the second polarizer **500**. Alternatively, the pattern retarder **620** may be disposed, for example, between the first substrate **100** and the first polarizer **400**.

The black matrix **627** may be disposed, for example, on lower surfaces of the first retarder **624** and the second retarder **625** to cover boundary portions between the first retarder **624** and the second retarder **625**. Therefore, the black matrix **627** overlaps boundary portions between the first retarder **624** and the second retarder **625**. The black matrix **627** partially blocks a light which is incident to the display panel, so that the viewing angle may be decreased in a column direction.

The black matrix **627** prevents the light from passing between pixel areas adjacent to each other. Therefore, the black matrix **627** prevents the lights passing through the pixel areas from interfering with each other.

The black matrix **627** may have, for example, a black color. The black matrix **627** may include, for example, a photoresist (PR).

The photoresist (PR) layer may be patterned, for example, using a mask to form the black matrix **627** by an exposure process.

The black matrix **627** may be arranged, for example, to be parallel with the reflection axis Ra of the first polarizer **400**.

For example, the black matrix **627** may be formed to have a linear shape extending in a row direction. The black matrix **627** of the pattern retarder **620** may be disposed, for example, in a row direction, so that the viewing angle may be decreased in a column direction. Therefore, a reddish phenomenon may be prevented. When the black matrix **627** of the pattern retarder **620** is formed to extend in the row direction, the reflection axis Ra of the first polarizer **400** of the display panel does not need to be rotated.

Alternatively, the black matrix **627** of the pattern retarder **620** may be formed to have, for example, a dotted pattern in a column direction. In this case, because the black matrix **627** having a dotted pattern extends in the column direction, the reflection axis Ra of the first polarizer **400** is controlled to be rotated about 90 degrees, to thereby decrease the viewing angle.

The absorption axis Tb of the second polarizer **500** is, for example, parallel to the reflection axis Ra of the first polarizer **400**. The black matrix **627** of the pattern retarder **620** is disposed to be, for example, parallel to the reflection axis Ra of the first polarizer **400**, so that the viewing angle may be decreased in a column direction of the display panel. Therefore, a reddish phenomenon may be prevented.

FIG. **9** is a cross-sectional view illustrating a display panel in accordance with an example embodiment including a parallax barrier layer. FIG. **10** is a cross-sectional view illustrating a display panel in accordance with an example embodiment including a parallax barrier layer.

A viewing angle control layer **600** may include, for example, a parallax barrier layer **630**.

The parallax barrier layer **630** may include, for example, a plurality of parallax barriers **631** and a wire grid polarizer **632** disposed between the plurality of parallax barriers **631**.

The parallax barrier **630** may be formed in, for example, a matrix-shape and a stripe-shape.

A light emitted from a backlight assembly **700** is incident to the parallax barriers **631**, and thus the light may be reflected. When a light passes through the wire grid polarizer **632**, an image may be displayed to a viewer.

The parallax barrier layer **630** may extend, for example, in a row direction of the display panel.

The parallax barrier layer **630** includes, for example, a parallax barrier **631**, to thereby block a light. Therefore, a cross talk may be prevented and brightness may be increased. Accordingly, the parallax barrier **631** partially blocks a light, so that a viewing angle may be decreased in a column direction of the display panel.

The absorption axis Tb of the second polarizer **500** may be, for example, parallel to the reflection axis Ra of the first polarizer **400**. The parallax barrier **631** of the parallax barrier layer **630** is, for example, parallel to the reflection axis Ra of the first polarizer **400**, so that the viewing angle may be decreased in a column direction. Therefore, a reddish phenomenon may be prevented.

The parallax barrier **631** may reflect a light emitted from a backlight assembly **700**. The light emitted from a backlight assembly **700** may pass through the wire grid polarizer **632**.

The parallax barrier **631** may include, for example, a light reflecting material. Examples of a light reflecting material may include but are not limited to titanium dioxide, zinc oxide, zinc sulfide, zinc phosphate, calcium carbonate, alumina, silica, antimony oxide, barium sulfide, lytopene (coprecipitate of barium sulfide and zinc oxide), calcined kaolin, lead carbonate, magnesium oxide, etc. These may be used alone or in a mixture thereof.

In the present example embodiment, the parallax barrier layer **630** is disposed on the second polarizer **500**.

Alternatively, in an example embodiment, as shown in FIG. **10**, the parallax barrier layer **630** may be disposed between the first substrate **100** and the first polarizer **400**.

Having described example embodiments of the present invention, it is further noted that it is readily apparent to those of ordinary skill in the art that various modifications may be made without departing from the spirit and scope of the invention which is defined by the metes and bounds of the appended claims.

What is claimed is:

1. A display panel, comprising:

a first substrate;

a second substrate facing the first substrate;

a liquid crystal layer disposed between the first substrate and the second substrate;

a first polarizer disposed on a lower surface of the first substrate and including a first polarizing layer and a second polarizing layer stacked on each other, wherein the first polarizing layer comprises an isotropic macromolecular material and the second polarizing layer comprises a macromolecular material having a positive birefringence;

a second polarizer disposed on an upper surface of the second substrate; and

a viewing angle control layer disposed on the first polarizer, wherein the viewing angle control layer is configured to control a viewing angle of a column direction of the display panel,

wherein the viewing angle control layer comprises a pattern retarder,

wherein the pattern retarder comprises:

a base layer having a birefringence;

a pattern retarding layer disposed on a lower surface of the base layer and including patterns having a different optical axis from each other; and

an adhesive layer disposed on a lower surface of the pattern retarding layer,

wherein the pattern retarding layer comprises:

a first retarder configured to convert a first light to a first polarization;

a second retarder configured to convert a second light to a second polarization; and

a black matrix disposed on lower surfaces of the first retarder and the second retarder to cover boundary portions between the first retarder and the second retarder, and

wherein the black matrix makes contact with the lower surfaces of the first and second retarders.

2. The display panel of claim 1, wherein the viewing angle control layer is disposed on the upper surface of the second polarizer.

3. The display panel of claim 1, wherein the viewing angle control layer is disposed between the first substrate and the first polarizer.

4. The display panel of claim 1, wherein the first polarizer is a reflection polarizer, and the second polarizer is an absorption polarizer.

5. The display panel of claim 1, wherein the first polarizer and the second polarizer is a reflection polarizer.

6. The display panel of claim 1, wherein an absorption axis of the second polarizer is parallel to a reflection axis of the first polarizer.

7. The display panel of claim 1, wherein the viewing angle control layer comprises a viewing angle control film, and the viewing angle control film includes a base sheet and a protrusion portion protruding from an upper surface of the base sheet and extending in a direction.

8. The display panel of claim 7, wherein an absorption axis of the viewing angle control layer is parallel to a reflection axis of the first polarizer.

9. The display panel of claim 1, wherein the black matrix is parallel to a reflection axis of the first polarizer.

10. The display panel of claim 1, wherein the viewing angle control layer comprises a parallax barrier layer, and the parallax barrier layer includes a plurality of parallax barriers and a wire grid polarizer disposed between the plurality of parallax barriers.

11. The display panel of claim 10, wherein an absorption axis of the parallax barrier is parallel to a reflection axis of the first polarizer.

12. The display panel of claim 1, wherein the first polarizer comprises:

a first layer comprising the first polarizing layer;

a second layer stacked directly on the first layer, the

second layer comprising the second polarizing layer;

a third layer stacked directly on the second layer, the third

layer comprising the first polarizing layer; and

a fourth layer stacked directly on the third layer, the fourth layer comprising the second polarizing layer.

13. A display device, comprising:

a display panel comprising:

a first substrate, a second substrate facing the first substrate,

a liquid crystal layer disposed between the first substrate and the second substrate, a first polarizer

disposed on a lower surface of the first substrate and

including a first polarizing layer and a second polarizing layer stacked on each other, a second polarizer

13

disposed on an upper surface of the second substrate, and a viewing angle control layer disposed on the first polarizer,

wherein the viewing angle control layer is configured to a viewing angle of a column direction of the display panel; and

a backlight assembly configured to provide a light to the display panel,

wherein the viewing angle control layer comprises a pattern retarder,

wherein the pattern retarder comprises:

a base layer having a birefringence;

a pattern retarding layer disposed on a lower surface of the base layer and including patterns having a different optical axis from each other; and

an adhesive layer disposed on a lower surface of the pattern retarding layer,

wherein the pattern retarding layer comprises:

a first retarder configured to convert a first light to a first polarization;

a second retarder configured to convert a second light to a second polarization; and

a black matrix disposed on lower surfaces of the first retarder and the second retarder to cover boundary portions between the first retarder and the second retarder, and

wherein the black matrix makes contact with the lower surfaces of the first and second retarders, and

wherein the first polarizing layer of the first polarizer comprises an isotropic macromolecular material and the second polarizing layer of the first polarizer comprises a macromolecular material having a positive birefringence.

14. The display apparatus of claim 13, wherein the viewing angle control layer is disposed on the upper surface of the second polarizer.

15. The display device of claim 13, wherein the viewing angle control layer is disposed between the first substrate and the first polarizer.

16. The display device of claim 13, wherein the viewing angle control layer comprises a viewing angle control film, and the viewing angle control film includes a base sheet and a protrusion portion protruding from an upper surface of the base sheet and extending in a direction.

17. The display device of claim 16, wherein the protrusion portion includes a light reflecting material and a light absorbing material.

18. The display device of claim 17, wherein the light reflecting material of the protrusion portion includes at least one selected from the group consisting of titanium dioxide, zinc oxide, zinc sulfide, zinc phosphate, calcium carbonate, alumina, silica, antimony oxide, barium sulfide, lytopene (co-precipitate of barium sulfide and zinc oxide), calcined kaolin, lead carbonate, and magnesium oxide and wherein the light absorbing material of the protrusion portion includes at least one material selected from the group consisting of carbon black, spinel black, rutile black, and iron black.

19. The display device of claim 13, wherein the viewing angle control layer comprises a parallax barrier layer, and the parallax barrier layer includes a plurality of parallax barriers and a wire grid polarizer disposed between the plurality of parallax barriers.

20. The display device of claim 19, wherein the plurality of parallax barriers include at least one light reflecting

14

material selected from the group consisting of titanium dioxide, zinc oxide, zinc sulfide, zinc phosphate, calcium carbonate, alumina, silica, antimony oxide, barium sulfide, lytopene (co-precipitate of barium sulfide and zinc oxide), calcined kaolin, lead carbonate, and magnesium oxide.

21. The display device of claim 13, wherein an absorption axis of the second polarizer is perpendicular to an absorption axis of the first polarizer or wherein a reflection axis of the second polarizer is parallel to an absorption axis of the first polarizer.

22. A display device, comprising:

a display panel comprising:

a first substrate, a second substrate facing the first substrate, a liquid crystal layer disposed between the first substrate and the second substrate, a first polarizer disposed on a lower surface of the first substrate and including a first polarizing layer and a second polarizing layer stacked on each other, a second polarizer disposed on an upper surface of the second substrate, and a viewing angle control layer disposed on the first polarizer,

wherein the viewing angle control layer is configured to control a viewing angle of a column direction of the display panel, an optical sheet disposed on a lower surface of the first polarizer; and

a backlight assembly disposed on a lower surface of the optical sheet and configured to provide a light to the display panel,

wherein the viewing angle control layer comprises a pattern retarder,

wherein the pattern retarder comprises:

a base layer having a birefringence;

a pattern retarding layer disposed on a lower surface of the base layer and including patterns having a different optical axis from each other; and

an adhesive layer disposed on a lower surface of the pattern retarding layer,

wherein the pattern retarding layer comprises:

a first retarder configured to convert a first light to a first polarization;

a second retarder configured to convert a second light to a second polarization; and

a black matrix disposed on lower surfaces of the first retarder and the second retarder to cover boundary portions between the first retarder and the second retarder, and

wherein the black matrix makes contact with the lower surfaces of the first and second retarders, and

wherein the first polarizing layer of the first polarizer comprises an isotropic macromolecular material and the second polarizing layer of the first polarizer comprises a macromolecular material having a positive birefringence.

23. The display device of claim 22, wherein the first polarizing layer includes a birefringence material and wherein the second polarizing layer includes a material having a reflective index different from the birefringence material of the first polarizing layer.

24. The display device of claim 22, wherein the backlight assembly includes a light guide plate, a light source disposed at a side of the backlight assembly and configured to emit light to the light guide plate, and a reflection plate disposed on a lower surface of the light guide plate and configured to reflect the light emitted to the light guide plate.

专利名称(译)	具有包含各向同性高分子材料的第一偏振层和包含具有正双折射的高分子材料的第二偏振层的显示装置，所述第一和第二偏振层彼此堆叠		
公开(公告)号	US9436034	公开(公告)日	2016-09-06
申请号	US14/017672	申请日	2013-09-04
[标]申请(专利权)人(译)	三星显示有限公司		
申请(专利权)人(译)	三星DISPLAY CO. , LTD.		
当前申请(专利权)人(译)	三星DISPLAY CO. , LTD.		
[标]发明人	KIM SANG JAE KI BOO KAN KIM JI HYE DO HEE WOOK PARK JAE WON SUH DUCK JONG LEE JUNG HUN LEE HYOUNG JOO CHO SEON AH HONG HYO SUNG		
发明人	KIM, SANG-JAE KI, BOO-KAN KIM, JI-HYE DO, HEE-WOOK PARK, JAE-WON SUH, DUCK-JONG LEE, JUNG-HUN LEE, HYOUNG-JOO CHO, SEON-AH HONG, HYO-SUNG		
IPC分类号	G02F1/1335		
CPC分类号	G02F1/133536 G02F1/133524 G02F2001/133531		
优先权	1020120133365 2012-11-23 KR		
其他公开文献	US20140146273A1		
外部链接	Espacenet USPTO		

摘要(译)

显示面板包括第一基板，第二基板，液晶层，第一偏振器，第二偏振器和视角控制层。第二基板面向第一基板。液晶层设置在第一基板和第二基板之间。第一偏振器设置在第一基板的下表面上，并包括彼此堆叠的第一偏振层和第二偏振层。第二偏振器设置在第二基板的上表面上。视角控制层设置在第一偏振器上，并被配置为控制显示面板的列方向的视角。

