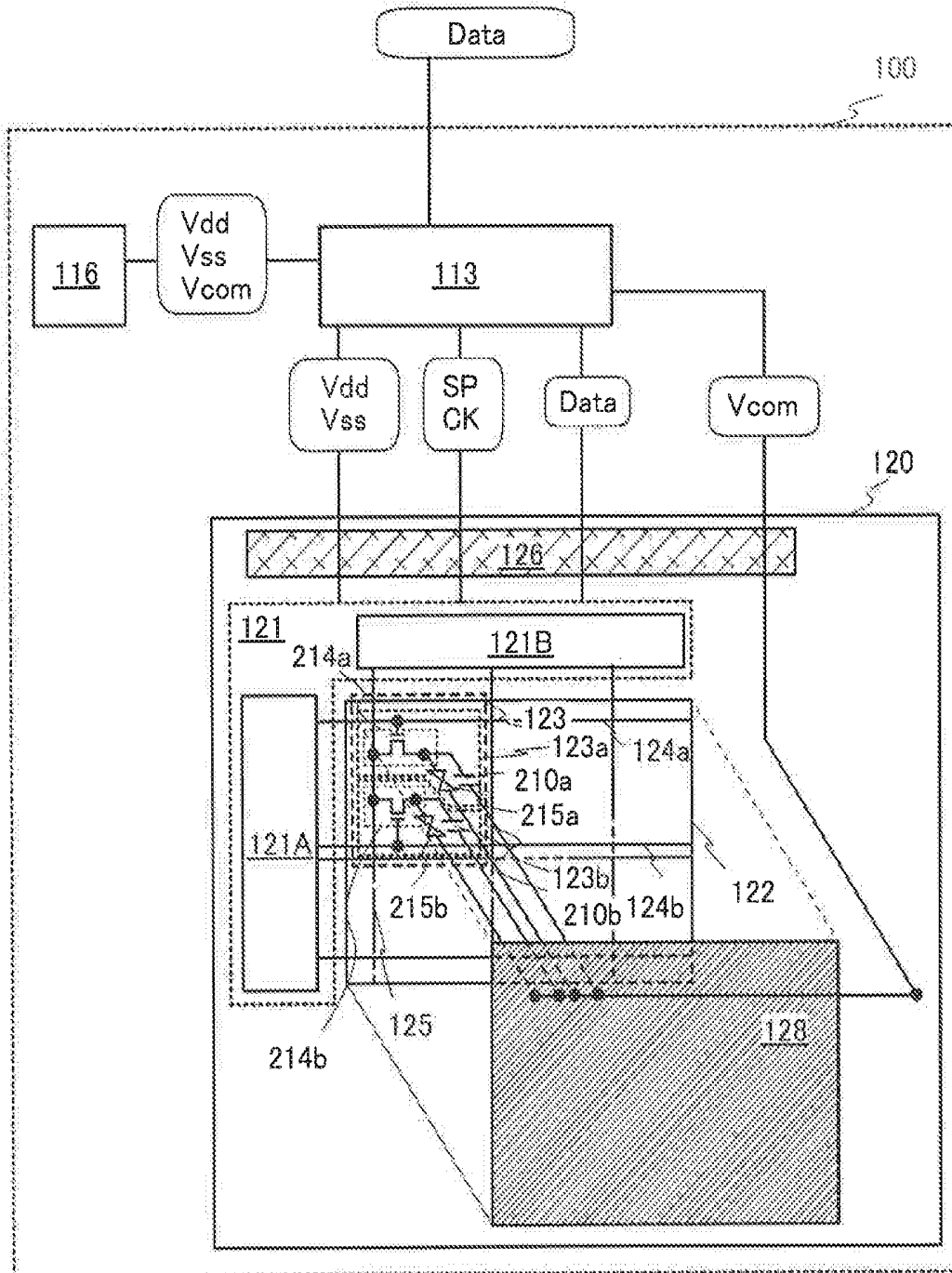

FIG. 1



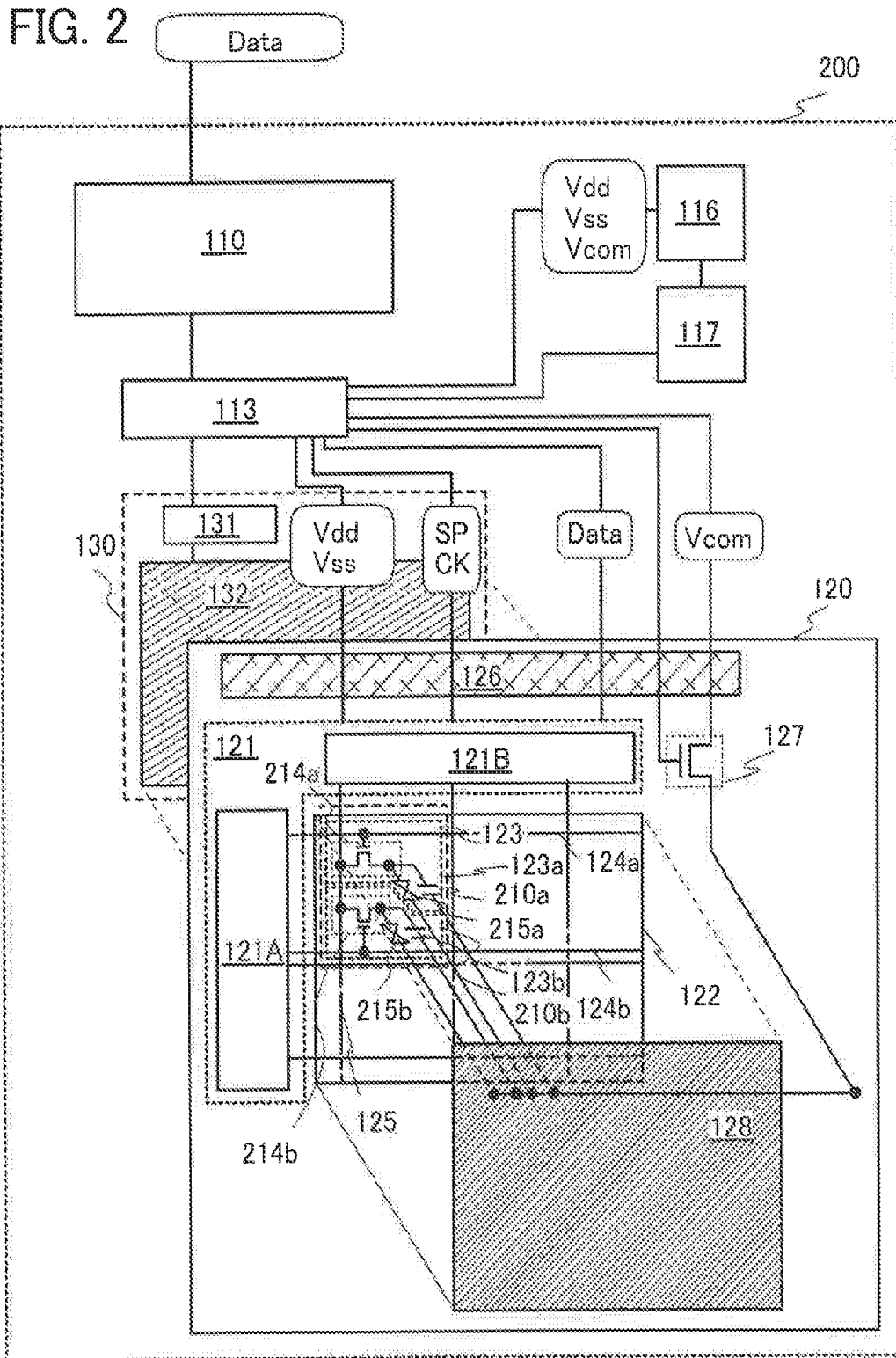

FIG. 3

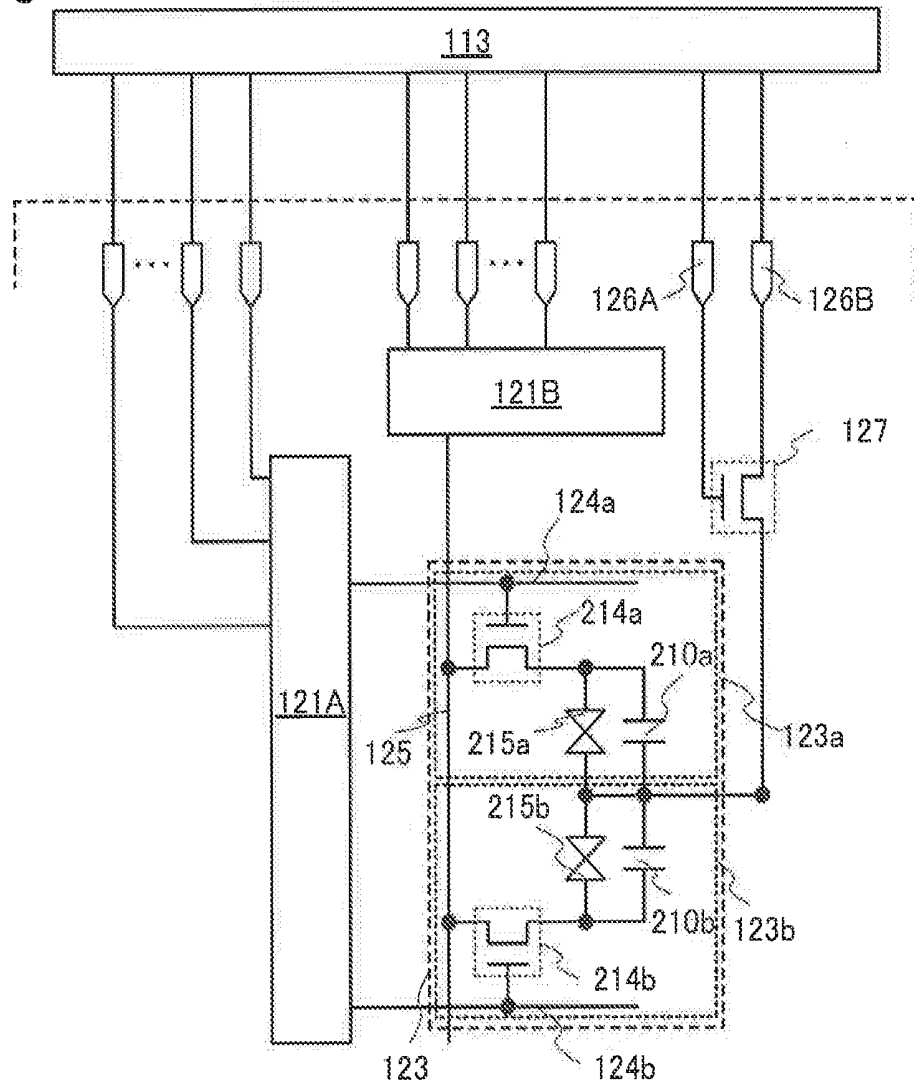

FIG. 4

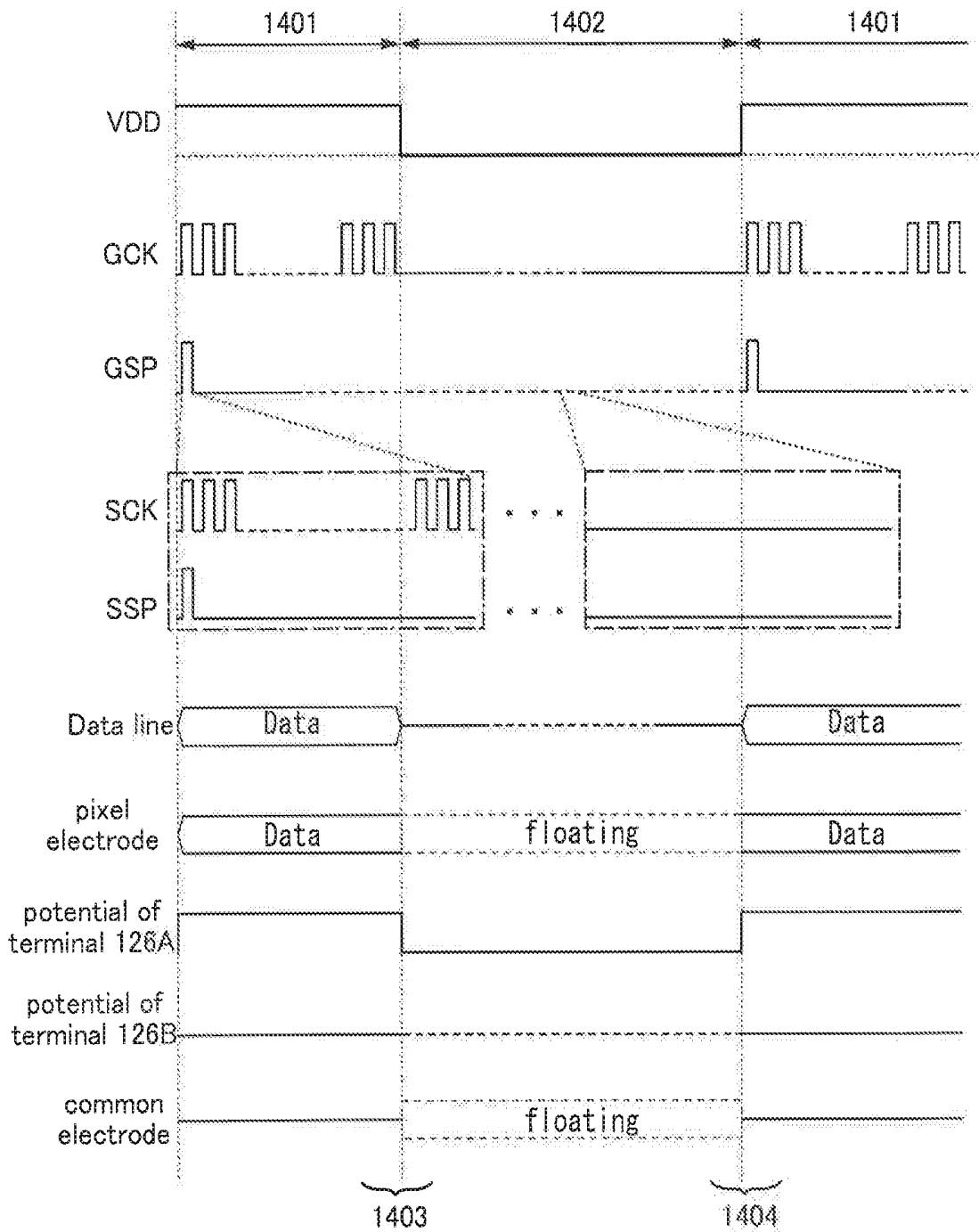

FIG. 5A

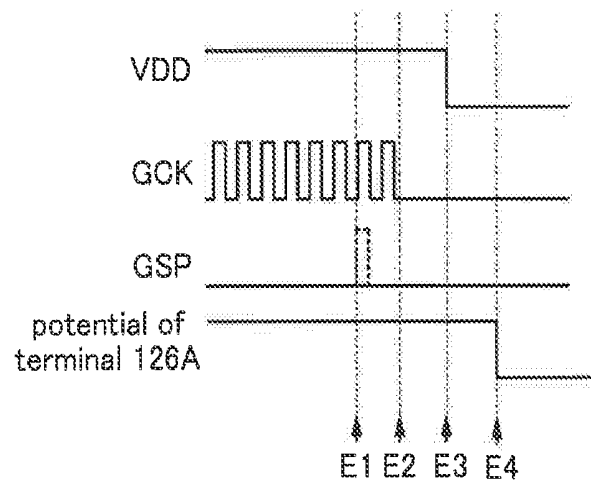

FIG. 5B

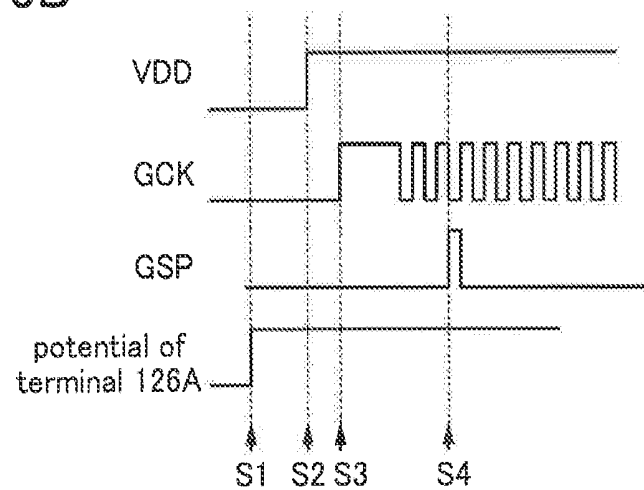

FIG. 6

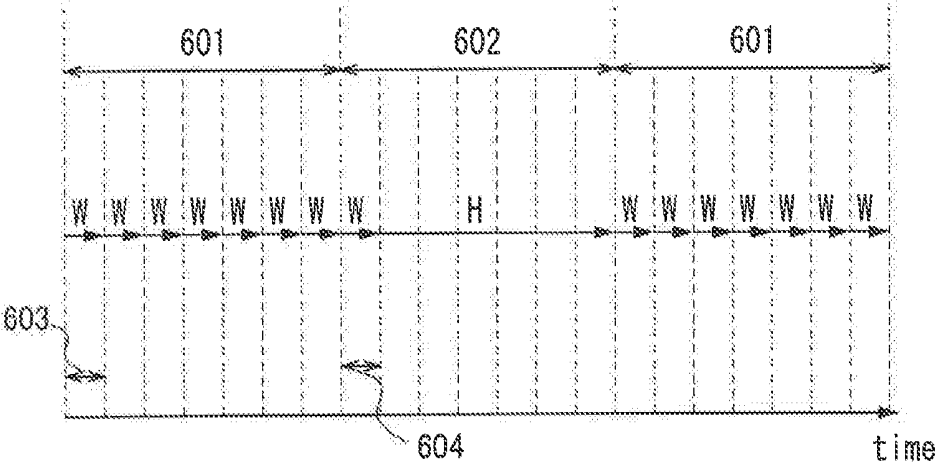

FIG. 7

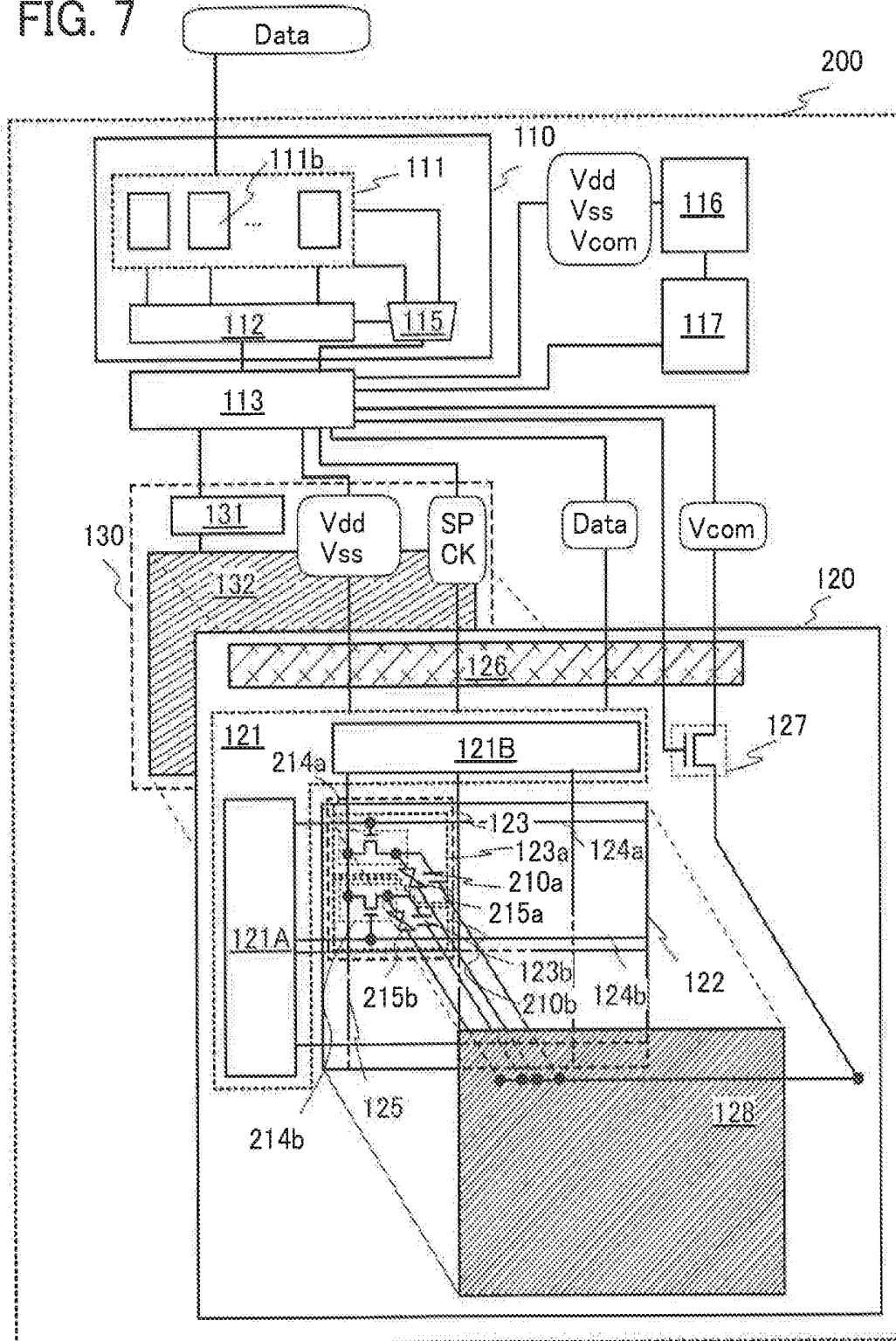

FIG. 8A

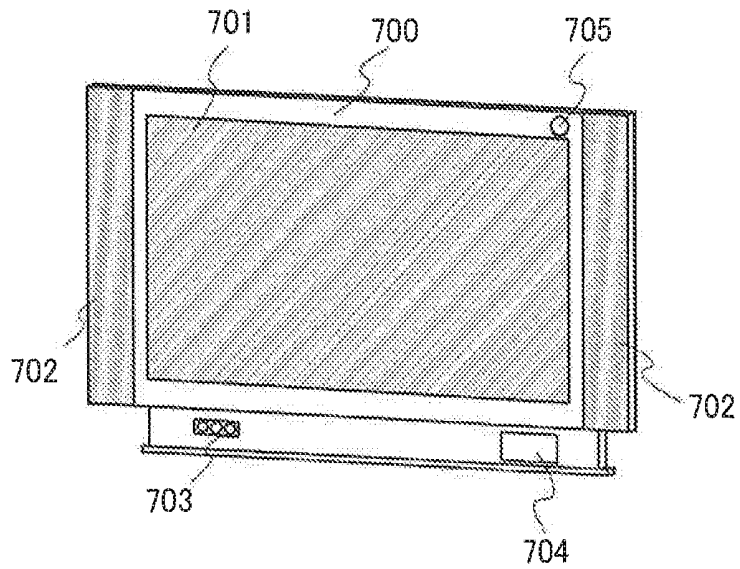

FIG. 8B

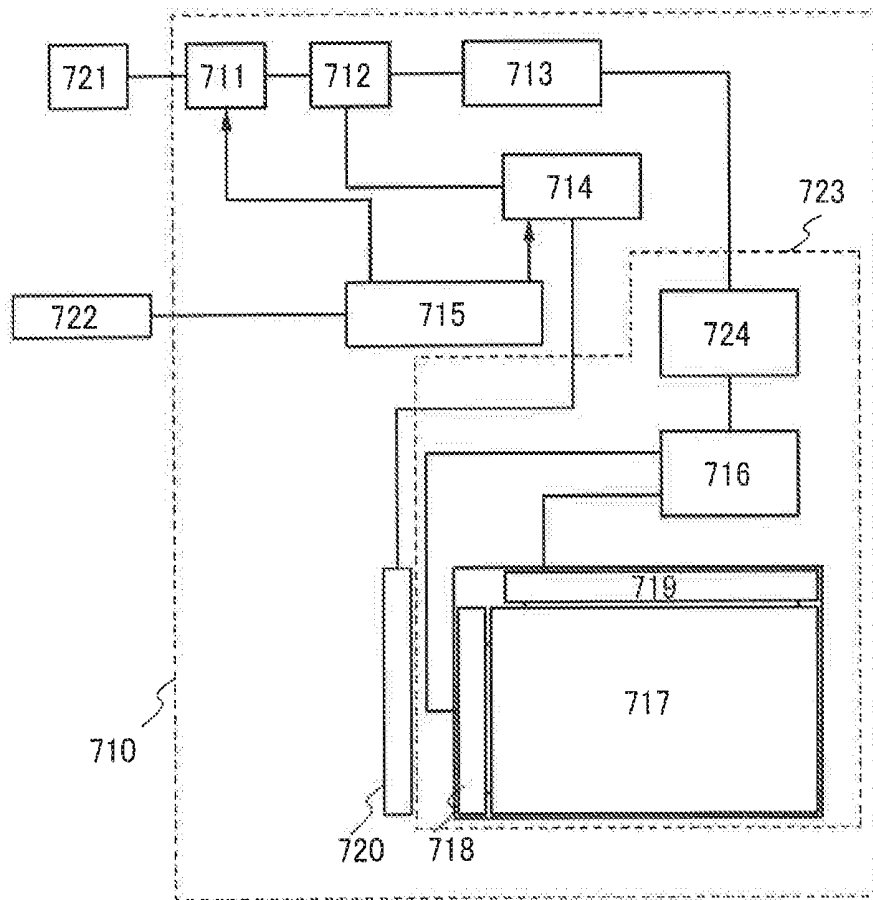

FIG. 9A

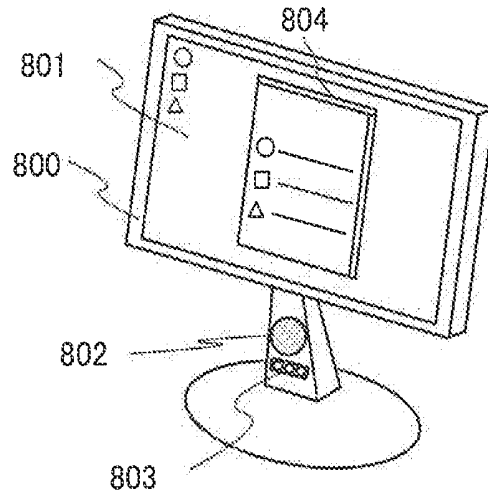

FIG. 9B

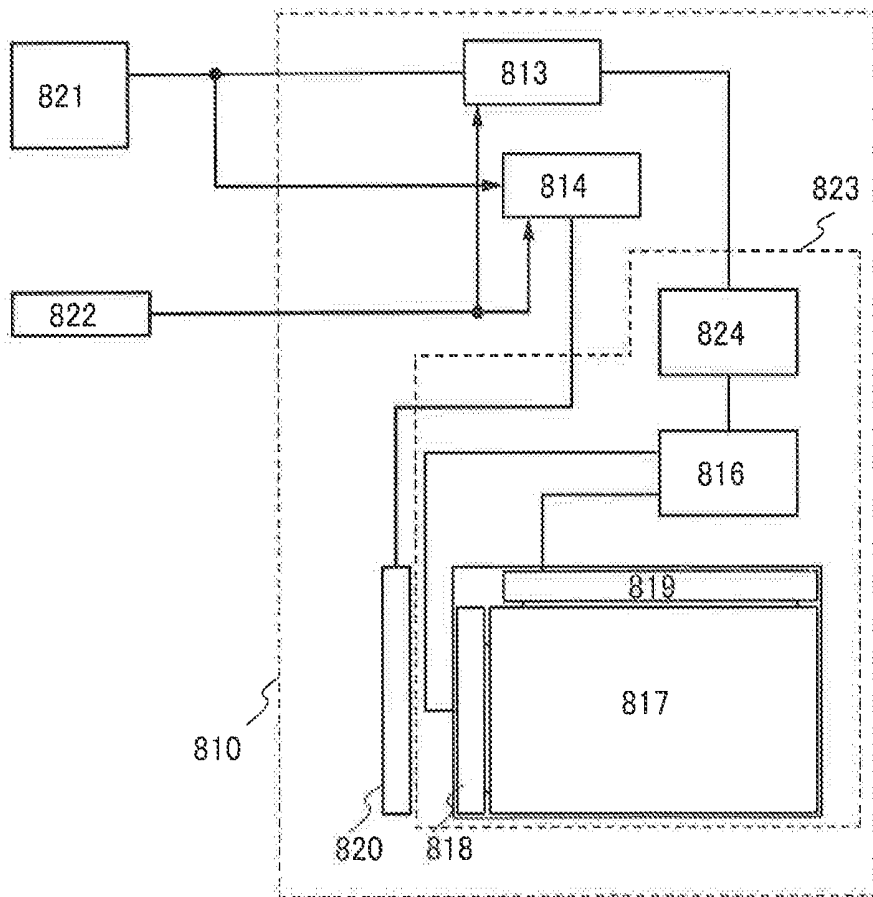

FIG. 10A

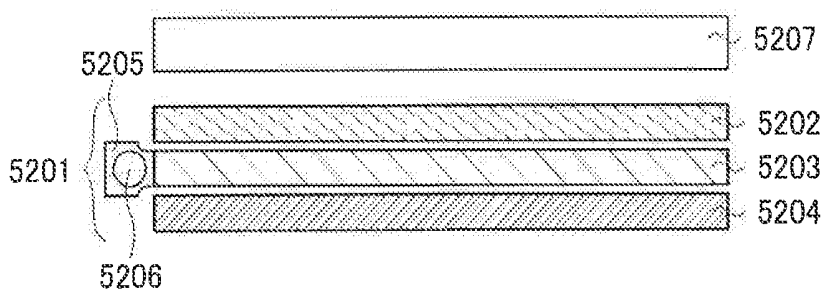

FIG. 10B

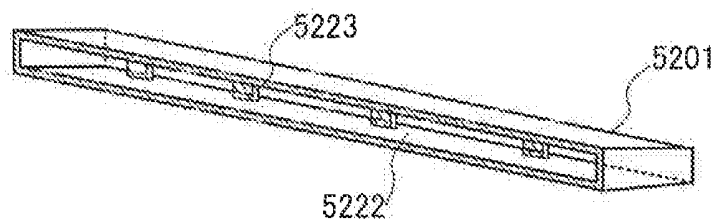

FIG. 10C

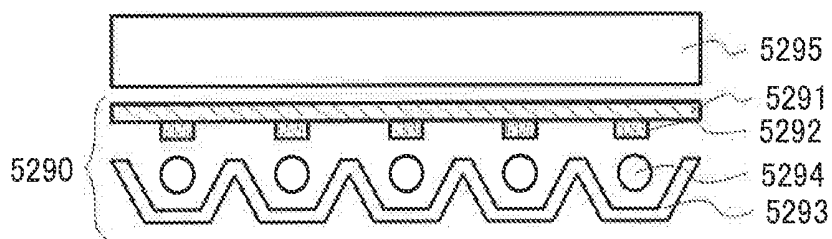

FIG. 11A

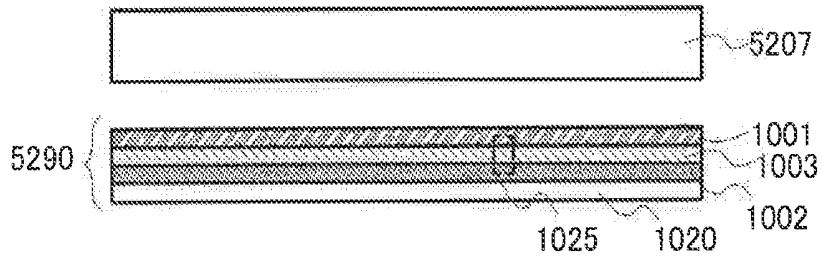

FIG. 11B

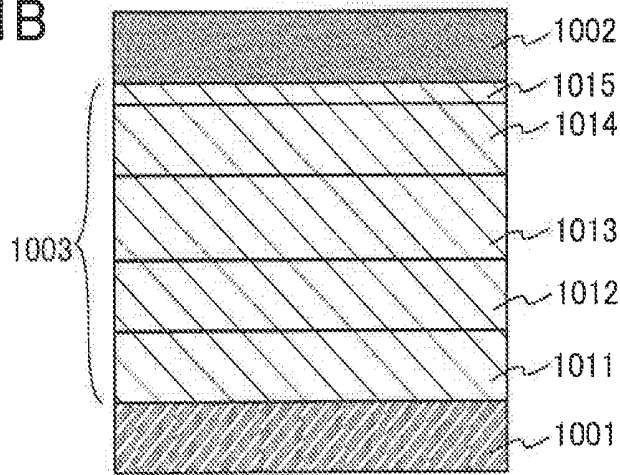

FIG. 11C

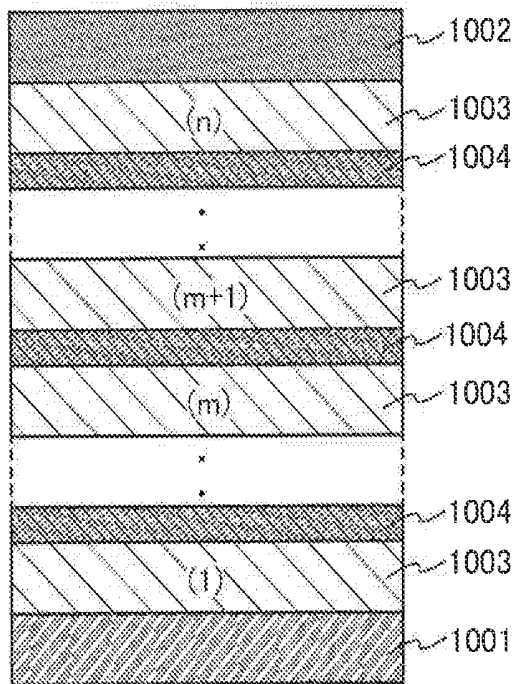

FIG. 12A

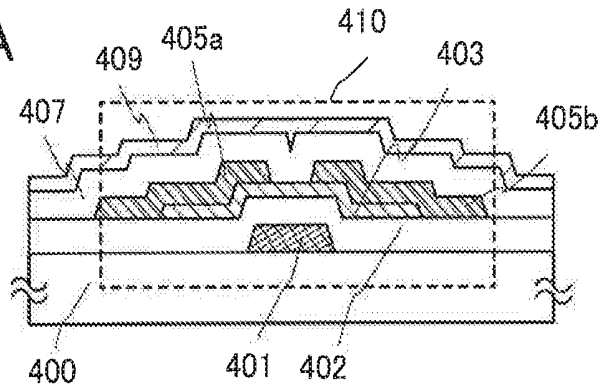

FIG. 12B

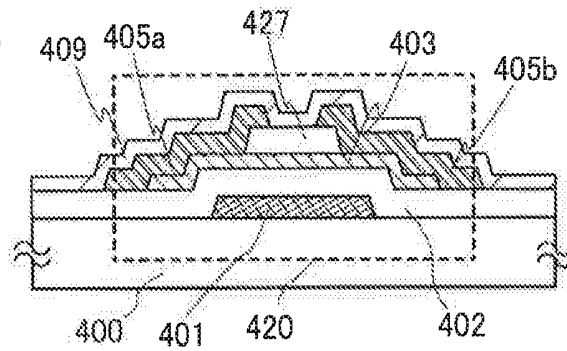

FIG. 12C

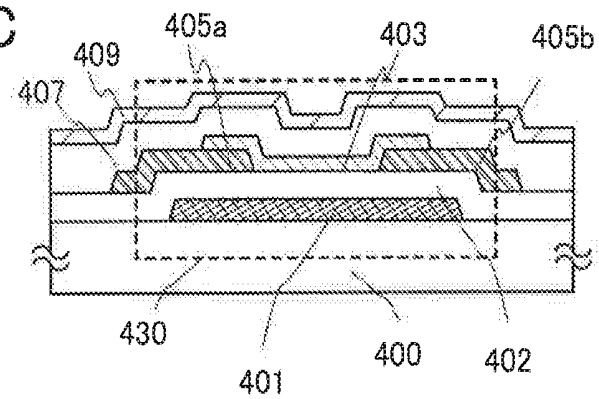

FIG. 12D

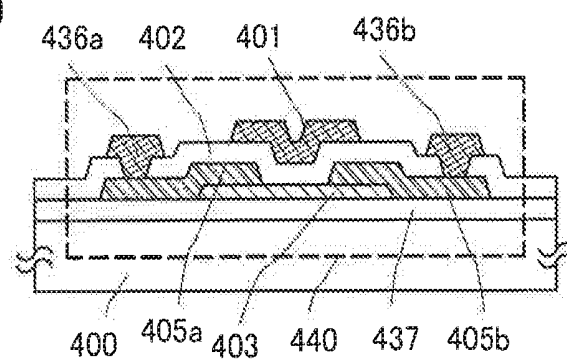

FIG. 13A

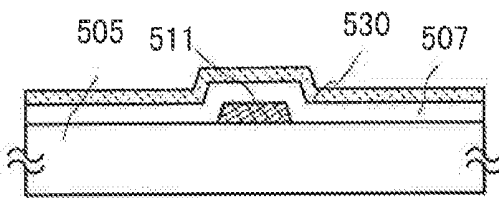

FIG. 13B

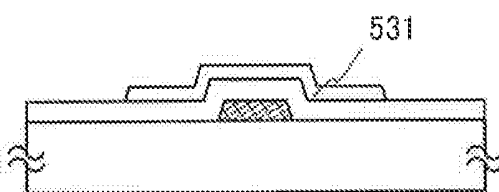

FIG. 13C

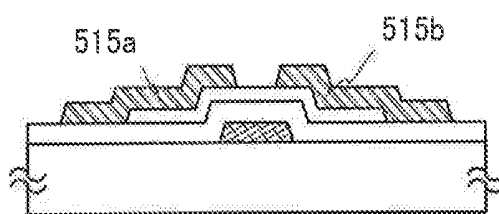

FIG. 13D

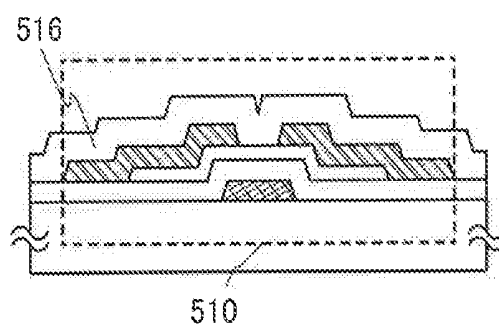

FIG. 13E

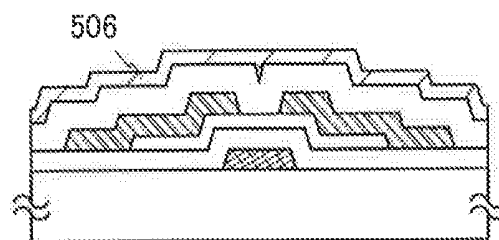

FIG. 14

(n-ch, L/W= 10/ 50 [μm] , T_{ox} = 100 [nm] , ϵ = 4.1)

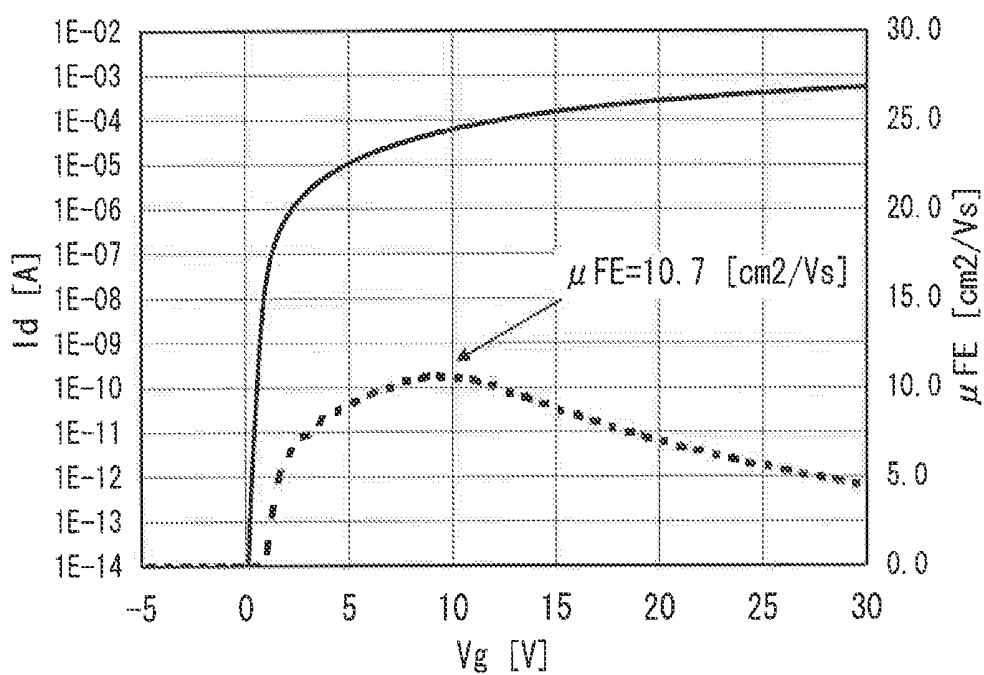

FIG. 15

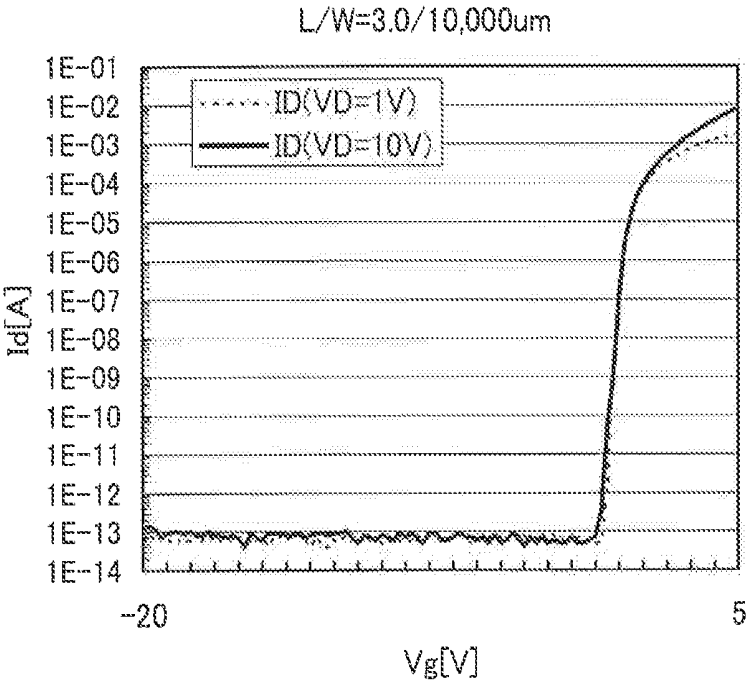

FIG. 16

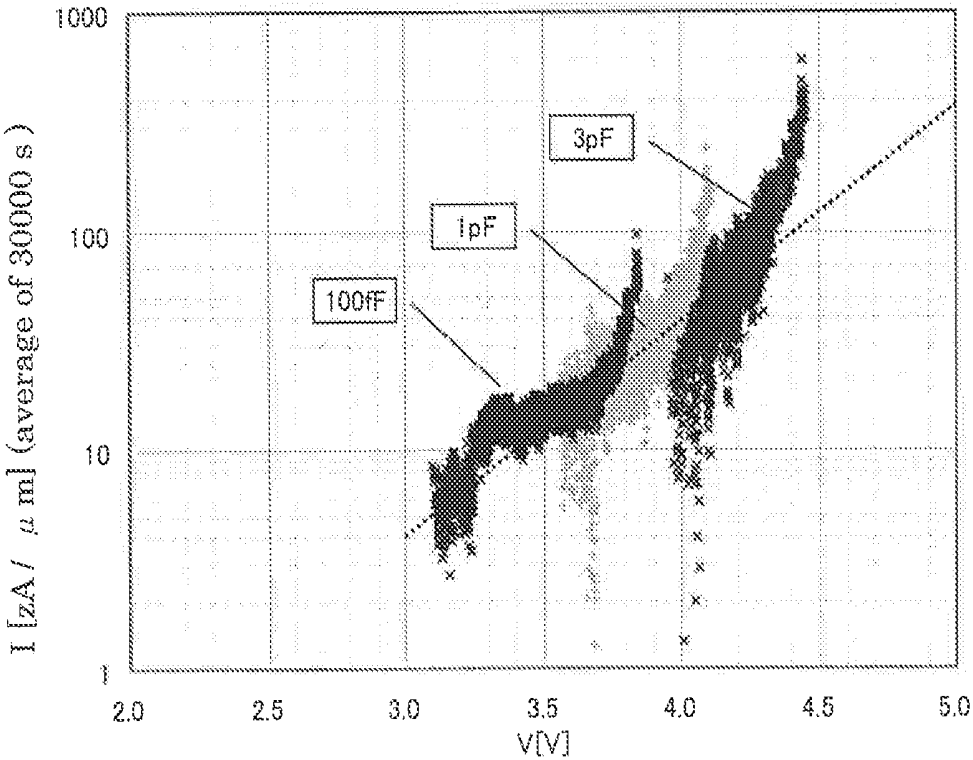

FIG. 17A

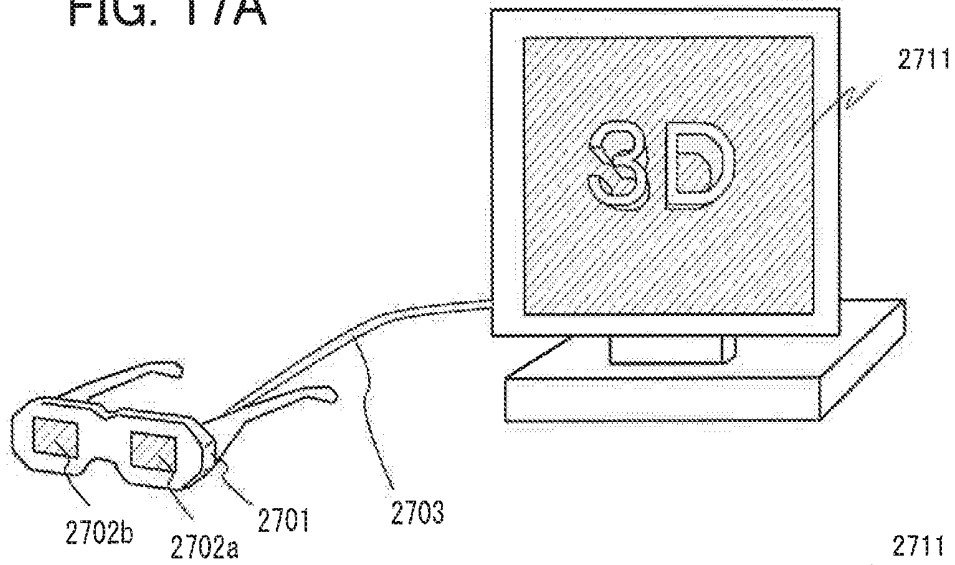

FIG. 17B

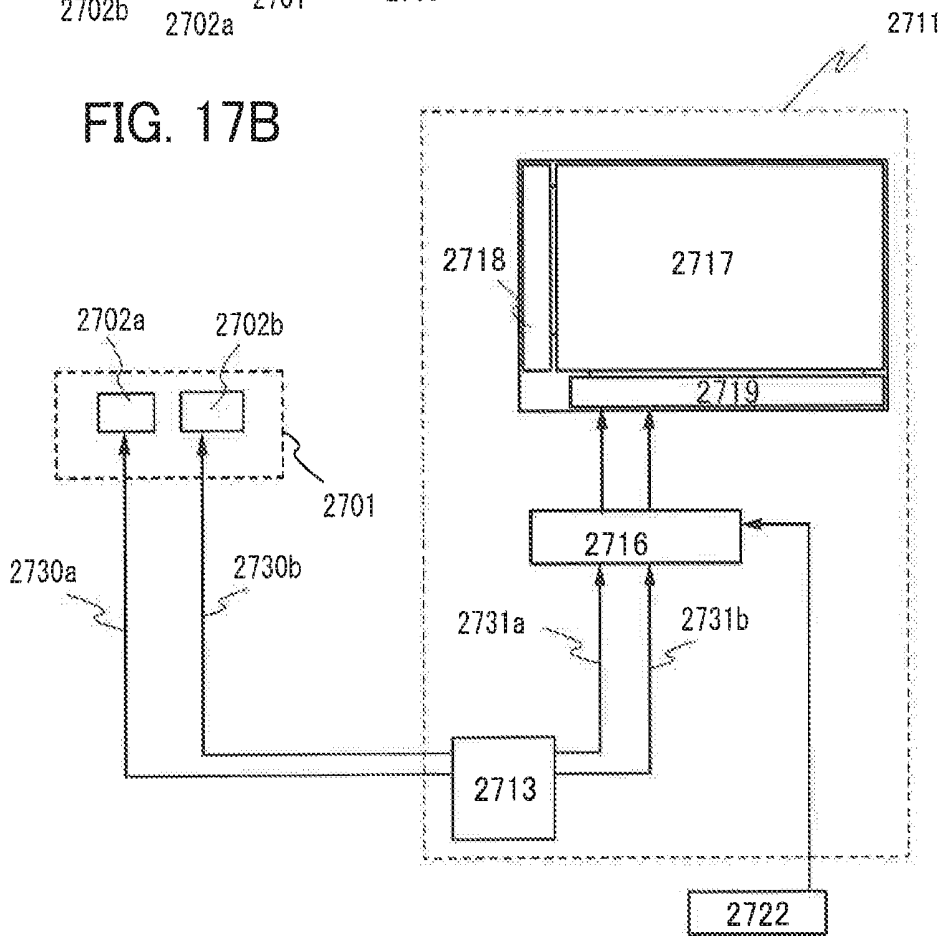

FIG. 18A

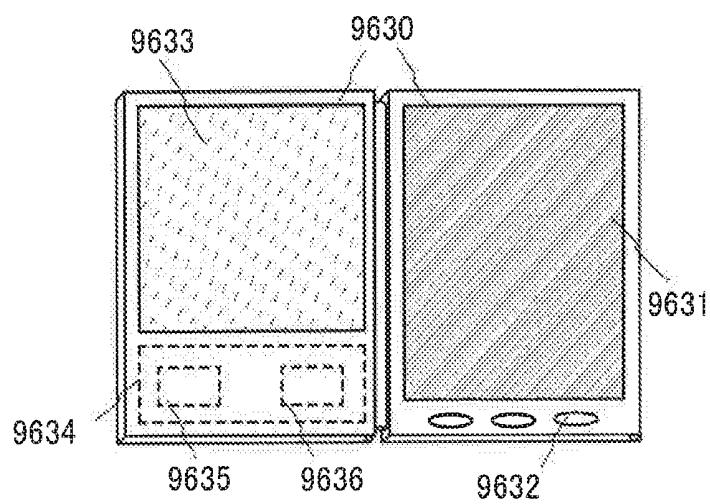

FIG. 18B

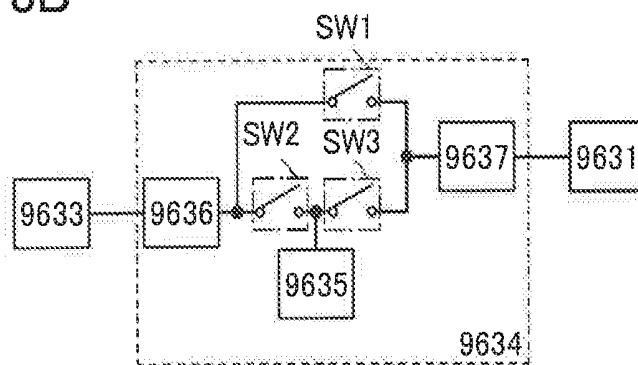

FIG. 19

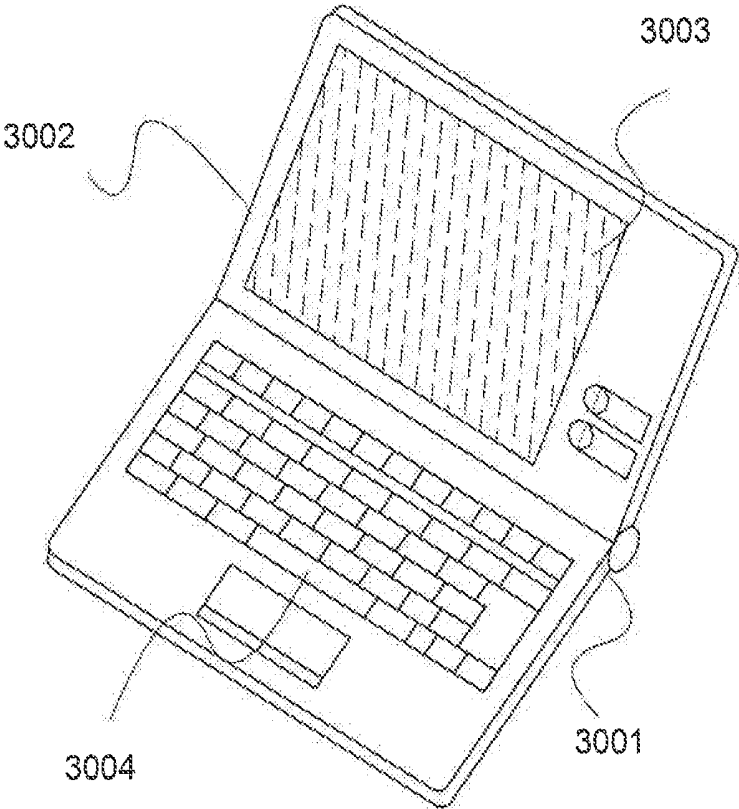
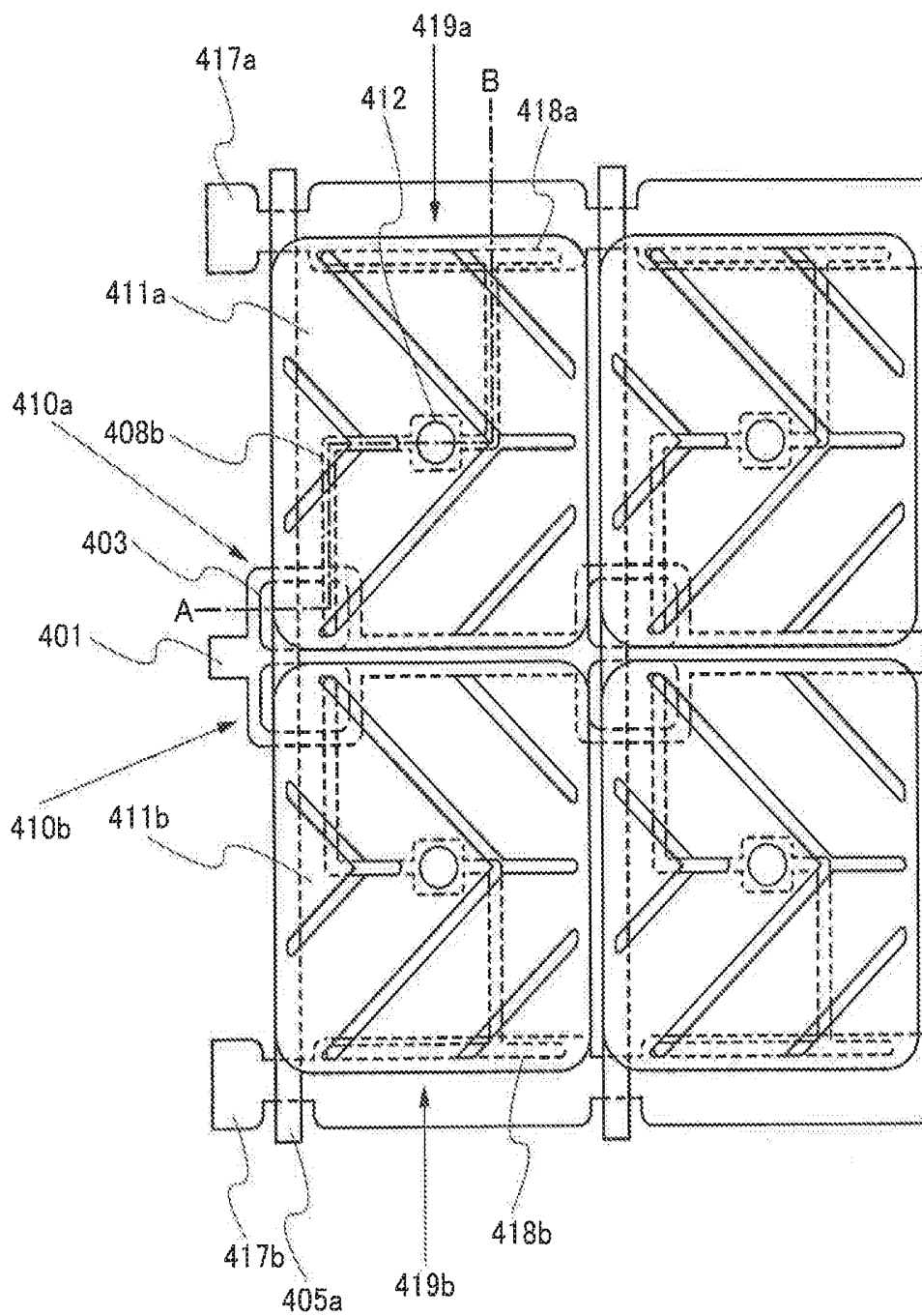

FIG. 20



DISPLAY DEVICE**CROSS-REFERENCE TO RELATED APPLICATIONS**

[0001] This application is a continuation of U.S. application Ser. No. 15/451,541, filed Mar. 7, 2017, now allowed, which is a continuation of U.S. application Ser. No. 14/505,593, filed Oct. 3, 2014, now U.S. Pat. No. 9,599,860, which is a continuation of U.S. application Ser. No. 13/011,535, filed Jan. 21, 2011, now U.S. Pat. No. 8,879,010, which claims the benefit of a foreign priority application filed in Japan as Serial No. 2010-012665 on Jan. 24, 2010, all of which are incorporated by reference.

TECHNICAL FIELD

[0002] One embodiment of the present invention relates to a display device including a field-effect transistor using an oxide semiconductor.

BACKGROUND ART

[0003] A liquid crystal display panel including a thin film transistor using amorphous silicon as a driving element of liquid crystal is widely used in commercial products such as a monitor of a computer and a liquid crystal television. A manufacturing technique of a thin film transistor using amorphous silicon is already established and a liquid crystal panel with more than 60 inches has been produced.

[0004] Since operation speed of a thin film transistor using amorphous silicon is slow and any further high performance cannot be expected, a thin film transistor using polysilicon has been developed. However, a crystallization step is required for making polysilicon, which leads to cause variation in transistor characteristics or inhibit enlargement of a panel area.

[0005] In contrast, an oxide semiconductor material has been attracting attention as a transistor material besides a silicon based material. As an oxide semiconductor material, zinc oxide or a substance containing zinc oxide is known. Thin film transistors each of which is formed using an amorphous oxide (an oxide semiconductor) having an electron carrier concentration of lower than $10^{18}/\text{cm}^3$ are disclosed (see Patent Documents 1 to 3).

[0006] Liquid crystal display devices are widely used for display devices ranging from large-sized display devices such as television sets to small-sized display devices such as mobile phones. Therefore, the development of liquid crystal display devices is intended to achieve low-cost liquid crystal display devices and to provide high-value added liquid crystal display devices as well as to achieve a wide viewing angle and high image quality. In addition, as high-value added liquid crystal display devices, the development for low power consumption has also been underway.

[0007] In order to improve viewing angle characteristics of liquid crystal display devices, in a liquid crystal display device which performs display by aligning liquid crystal molecules in a gradient manner or a radical gradient manner, it is disclosed that one pixel is divided into a plurality of independent pixel regions and different signals are added to each divided pixel region in each given period (for example, see Patent Document 4).

[0008] Further, as a method for satisfying basic display quality such as brightness and contrast and achieving sufficient low power consumption, a driving method of a

display device in which a scanning period and a non-scanning period longer than the scanning period are set is disclosed (see Patent Document 5). Specifically, it is a driving method of a display device in which all data signal lines are electrically disconnected from a data signal driver in a break period in which all scan lines and data signal lines are in a non-selection state, so that a high impedance state is obtained.

REFERENCE**Patent Document**

- [0009] [Patent Document 1] Japanese Published Patent Application No. 2006-165527
 [0010] [Patent Document 2] Japanese Published Patent Application No. 2006-165528
 [0011] [Patent Document 3] Japanese Published Patent Application No. 2006-165529
 [0012] [Patent Document 4] Japanese Published Patent Application No. 2008-287042
 [0013] [Patent Document 5] Japanese Published Patent Application No. 2001-312253

DISCLOSURE OF INVENTION

[0014] Even when having an electron carrier concentration of lower than $10^{18}/\text{cm}^3$, an oxide semiconductor is a substantially n-type oxide semiconductor, and an on-off ratio of the thin film transistors disclosed in the above Patent Documents is only 10^3 . A reason of such low on-off ratio of the thin film transistors is high off current.

[0015] For example, in a liquid crystal panel, each pixel includes a storage capacitor provided in parallel to a pixel electrode driving liquid crystal. A transistor is turned on to apply an image signal to the pixel electrode and the storage capacitor, whereby potential is applied to liquid crystal and the storage capacitor is charged to given potential. When this writing operation is completed, the transistor is off until the next image signal is applied. At this time, when off current of the transistor is high, potential applied to the liquid crystal is fluctuated and electrical charges stored in the storage capacitor are discharged.

[0016] In a pixel, a relation between off current i of a transistor, an electrostatic capacitance C , voltage fluctuation V , and a holding time T can be expressed by $CV=iT$. For example, when off current of a transistor is 0.1 pA, electrostatic capacitance of a storage capacitor is 0.1 pF, and one frame period is 16.6 ms, voltage fluctuation V of a pixel in one frame becomes as follows:

$$0.1 [\text{pF}] \times V = 0.1 [\text{pA}] \times 16.6 [\text{ms}]$$

$$[0017] \quad V = 16.6 [\text{mV}]$$

[0018] In the case where the maximum driving voltage of liquid crystal is 5 V and 256 grayscale is displayed, a grayscale voltage for 1 grayscale is approximately 20 mV. When voltage fluctuation of a pixel is 16.6 mV as described above, this corresponds to a grayscale voltage for approximately 1 grayscale. Further, in the case where 1024 grayscale is displayed, a grayscale voltage for 1 grayscale is approximately 5 mV, and when voltage fluctuation of a pixel is 16.6 mV, this corresponds to a grayscale voltage for 4 grayscales and thus influence of voltage fluctuation due to off current cannot be ignored. Consequently, not only characteristics of an on state (such as on current and field-effect

mobility) but also influence of off current of a transistor included in a display panel must be considered.

[0019] In the liquid crystal display device disclosed in Patent Document 1, an image signal is not input to each pixel included in a pixel portion in the inactive period. That is, a transistor for controlling the input of an image signal is kept turned off for a long period of time while an image signal is held in each pixel. Thus, the effect that leakage of an image signal through the transistor has on display of each pixel becomes apparent. Specifically, voltage applied to a liquid crystal element is reduced, whereby display deterioration (change) of a pixel including the liquid crystal element becomes apparent.

[0020] Further, the amount of leakage of an image signal through the transistor is changed in accordance with operation temperature of the transistor. Specifically, the amount of leakage of an image signal through the transistor is increased along with an increase in the operation temperature. Therefore, it is difficult for the liquid crystal display device disclosed in Patent Document 1 to maintain uniform display quality when being used in the outdoors where environments vary widely.

[0021] As described above, by simply using a transistor formed using an oxide semiconductor, it is difficult to achieve low power consumption and high image quality including improvement of a viewing angle. Thus, an object of one embodiment of the present invention is to reduce power consumption of a display device and suppress deterioration of display (reduction in display quality) as well as to achieve high image quality in a display device.

[0022] One embodiment of the present invention provides a display device having high image quality and low power consumption by using a transistor whose off current is reduced to an extremely low level. In order to reduce off current of a transistor, a semiconductor material whose width of a forbidden band (a band gap) is greater than that of a silicon semiconductor is used for forming a transistor, preferably the concentration of an impurity which serves as a carrier donor of the semiconductor material is reduced, in one embodiment of the present invention. Therefore, an oxide semiconductor whose energy gap is greater than or equal to 2 eV, preferably greater than or equal to 2.5 eV, more preferably greater than or equal to 3 eV is used for a semiconductor layer of a transistor (a layer forming a channel formation region) to reduce the concentration of an impurity which serves as a carrier donor included in the oxide semiconductor. Consequently, the off current of the transistor per micrometer of channel width can be reduced to lower than 10 zA/ μm at room temperature and lower than 100 zA/ μm at 85° C., which is an extremely low level.

[0023] As one mode of a transistor using an oxide semiconductor, a source electrode and a drain electrode part of which are formed of metal nitride are included, in addition to the above oxide semiconductor layer. A gate electrode of the transistor may be provided on a lower side (a substrate side), an upper side (the side opposite to the substrate side), or both sides of the oxide semiconductor layer with an insulating layer interposed therebetween. Further, a transistor whose maximum value of field-effect mobility is greater than or equal to 5 cm²/Vsec, preferably in the range of 10 cm²/Vsec to 150 cm²/Vsec in an on state, in addition to the characteristics of offstate is used. This is because by increas-

ing the operation speed of the transistor, writing operation or the like can be performed sufficiently even when density of a pixel is increased.

[0024] One embodiment of the present invention is a display device provided with a display panel in which pixels are provided in a matrix to display an image. Each pixel includes one or more unit. Each unit includes a plurality of subunits each of which includes a transistor where a gate electrode is provided to overlap with an oxide semiconductor layer with a gate insulating layer interposed therebetween, a pixel electrode which is connected to a source or drain side of the transistor and drives liquid crystal, a counter electrode provided so as to face the pixel electrode, and a liquid crystal layer provided between the pixel electrode and the counter electrode.

[0025] One embodiment of the present invention is a display device provided with a display panel which includes: a pixel portion in which pixels are provided in a matrix to display an image, each pixel including one or more units, each unit including a plurality of subunits each of which includes a transistor where a gate electrode is provided to overlap with an oxide semiconductor layer with a gate insulating layer interposed therebetween, a pixel electrode which is connected to a source or drain side of the transistor and drives liquid crystal, a counter electrode provided so as to face the pixel electrode, and a liquid crystal layer provided between the pixel electrode and the counter electrode; and a driver circuit portion which drives the pixel portion to display an image on a screen. The driver circuit portion has a function to perform a writing operation in which an image signal is written successively to a selected pixel to display an image. Such a function is achieved by using the above transistor.

[0026] One embodiment of the present invention is a display device provided with a display panel which includes: a pixel portion in which pixels are provided in a matrix to display an image, each pixel including one or more units, each unit including a plurality of subunits each of which includes a transistor where a gate electrode is provided to overlap with an oxide semiconductor layer with a gate insulating layer interposed therebetween, a pixel electrode which is connected to a source or drain side of the transistor and drives liquid crystal, a counter electrode provided so as to face the pixel electrode, and a liquid crystal layer provided between the pixel electrode and the counter electrode; and a driver circuit portion which drives the pixel portion to display an image on a screen. The driver circuit portion has a function to select an operation mode in which a writing operation is performed in which an image signal is written successively to a selected pixel to display an image and an operation mode in which operation of writing an image signal is stopped and a written image on the screen is held in the case where one image is displayed on the screen. Such a function is achieved by using the above transistor.

[0027] According to one embodiment of the present invention, a signal voltage applied to a pixel can be held stably by using a transistor whose off current is satisfactorily reduced. Consequently, a signal input to the pixel can be kept in a given state (the state in which an image signal is written), so that an image can be displayed stably.

[0028] According to one embodiment of the present invention, as a transistor provided in each pixel, a transistor whose channel formation region is formed using an oxide semiconductor layer is employed. When the oxide semiconductor

layer is highly purified, off current of the transistor at room temperature can be lower than 10 zA/ μm per micrometer of the channel width and off current of the transistor at 85° C. can be lower than 100 zA/ μm per micrometer of the channel width. Therefore, the amount of leakage of an image signal through the transistor can be reduced. That is, display deterioration (change) which occurs when the writing frequency of an image signal to a pixel including the transistor is reduced can be suppressed. Thus, power consumption of the liquid crystal display device can be reduced and display deterioration (reduction in display quality) can be suppressed.

[0029] Further, a pixel including a transistor whose off current is extremely reduced can maintain a constant state (a state in which an image signal is written), and thus can operate stably even in the case where a still image is displayed. In that case, since an increase in off current with an increase in operation temperature is small in the transistor, adverse effect that an external factor such as temperature has on leakage of an image signal in the pixel can be reduced. That is, the liquid crystal display device can suppress display deterioration (reduction in display quality) even when a still image is displayed by maintaining a state in which an image signal is written in the outdoors or the like where environments vary widely.

BRIEF DESCRIPTION OF DRAWINGS

[0030] In the accompanying drawings:

[0031] FIG. 1 is a block diagram illustrating a structure of a liquid crystal display device according to Embodiment 1;

[0032] FIG. 2 is a block diagram illustrating a structure of a liquid crystal display device according to Embodiment 1;

[0033] FIG. 3 is a diagram illustrating a structure of a driver circuit and a pixel of a liquid crystal display device according to Embodiment 1;

[0034] FIG. 4 is a timing chart illustrating operation of a liquid crystal display device according to Embodiment 1;

[0035] FIGS. 5A and 5B are timing charts illustrating operation of a display control circuit of a liquid crystal display device according to Embodiment 1;

[0036] FIG. 6 is a chart schematically showing the frequency of writing an image signal in a period in which a moving image is displayed and a period in which a still image is displayed;

[0037] FIG. 7 is a block diagram illustrating a structure of a liquid crystal display device according to Embodiment 1;

[0038] FIGS. 8A and 8B are diagrams illustrating a structure of a television set according to Embodiment 2;

[0039] FIGS. 9A and 9B are diagrams illustrating a structure of a monitor according to Embodiment 2;

[0040] FIGS. 10A to 10C are diagrams illustrating an example of a structure of a backlight of a liquid crystal display device;

[0041] FIGS. 11A to 11C are diagrams illustrating an example of a structure of a backlight of a liquid crystal display device;

[0042] FIGS. 12A to 12D are diagrams each illustrating an example of a transistor which can be applied to a liquid crystal display device;

[0043] FIGS. 13A to 13E are diagrams illustrating a transistor including an oxide semiconductor layer and a manufacturing method thereof;

[0044] FIG. 14 is a graph showing an example of V_g - I_d characteristics of a transistor formed using an oxide semiconductor;

[0045] FIG. 15 is a graph for showing characteristics of an off state, in V_g - I_d characteristics of a transistor formed using an oxide semiconductor;

[0046] FIG. 16 is a graph showing a relation between source-drain voltage V and off current I ;

[0047] FIGS. 17A and 17B are diagrams illustrating an example of a device which shows a 3D image which is a moving image or a still image with dedicated glasses with which an image of the display device is synchronized;

[0048] FIGS. 18A and 18B are diagrams illustrating an example of an electronic book reader according to the present invention;

[0049] FIG. 19 is a diagram illustrating an example of a computer according to the present invention;

[0050] FIG. 20 is a plan view illustrating an example of a pixel of a liquid crystal display device; and

[0051] FIG. 21 is a cross-sectional view illustrating an example of a pixel of a liquid crystal display device.

BEST MODE FOR CARRYING OUT THE INVENTION

[0052] Embodiments of the present invention are described below with reference to the accompanying drawings. However, the invention disclosed in this specification is not limited to the following description, and it is easily understood by those skilled in the art that modes and details can be variously changed without departing from the purpose and the scope of the present invention. Therefore, the invention disclosed in this specification should not be interpreted as being limited to the following description of the embodiments.

[0053] In the case where description is made with reference to drawings in embodiments, reference numerals are used to denote the same components in different drawings in some cases. Note that components illustrated in the drawings, that is, a thickness or a width of a layer, a region, or the like, a relative position, and the like are exaggerated in some cases for clarification in description of embodiments.

Embodiment 1

[0054] In this embodiment, one mode of a liquid crystal display device and a driving method of the liquid crystal display device are described with reference to FIG. 1, FIG. 2, FIG. 3, FIG. 4, FIGS. 5A and 5B, FIG. 6, and FIG. 7.

[0055] An example of each component of a liquid crystal display device 100 illustrated in this embodiment is described with reference to FIG. 1. The liquid crystal display device 100 includes a power supply 116, a display control circuit 113, and a display panel 120. In the case of a transmissive liquid crystal display device or a transreflective liquid crystal display device, a backlight portion which is one of lighting units may be further provided as a light source.

[0056] An image signal (image signal Data) is supplied to the liquid crystal display device 100 from an external device which is connected to the liquid crystal display device 100. Note that power supply potential (high power supply potential V_{dd} , low power supply potential V_{ss} , and common potential V_{com}) is supplied by turning on the power supply 116 of the liquid crystal display device and starting supply-

ing power, and a control signal (a start pulse SP and a clock signal CK) is supplied by the display control circuit 113.

[0057] Note that the high power supply potential V_{dd} is potential higher than reference potential, and the low power supply potential V_{ss} is potential lower than or equal to the reference potential. It is preferable that both the high power supply potential V_{dd} and the low power supply potential V_{ss} have such a level as to allow the transistor to operate. The high power supply potential V_{dd} and the low power supply potential V_{ss} are collectively referred to as a power supply voltage in some cases.

[0058] The common potential V_{com} may be any potential as long as it serves as a fixed potential to be a reference with respect to the potential of an image signal supplied to a pixel electrode. For example, the common potential may be ground potential.

[0059] The image signal Data may be appropriately inverted in accordance with dot inversion driving, source line inversion driving, gate line inversion driving, frame inversion driving, or the like to be supplied to the liquid crystal display device 100. In the case where the image signal is an analog signal, it may be converted to a digital signal through an A/D converter or the like to be supplied to the liquid crystal display device 100.

[0060] In this embodiment, the common potential V_{com} which is a fixed potential is supplied from the power supply 116 to a common electrode 128 and one of electrodes of a capacitor through the display control circuit 113.

[0061] The display control circuit 113 supplies a display panel image signal (Data), a control signal (specifically, a signal for controlling switching between a supply or a stop of a control signal such as a start pulse SP and a clock signal CK), and power supply potential (high power supply potential V_{dd} , low power supply potential V_{ss} , and common potential V_{com}) to the display panel 120.

[0062] The display panel 120 includes a liquid crystal element 215a and a liquid crystal element 215b between a pair of substrates (a first substrate and a second substrate), and a driver circuit portion 121 and a pixel portion 122 are provided over the first substrate. Further, the second substrate is provided with a common connection portion (also referred to as a common contact) and the common electrode 128 (also referred to as a counter electrode). Note that the first substrate and the second substrate are electrically connected to each other through the common connection portion; therefore, the common connection portion may be provided over the first substrate.

[0063] A plurality of gate lines 124 (124a and 124b) (scan lines) and a plurality of source lines 125 (signal lines) are provided in the pixel portion 122 and a plurality of pixels are provided in a matrix so that the pixels are surrounded by the gate lines 124 and the source lines 125. Note that in the display panel illustrated in this embodiment, the gate lines 124 (124a and 124b) are extended from a gate line driver circuit 121A and the source lines 125 are extended from a source line driver circuit 121B.

[0064] The liquid crystal display device disclosed in this specification includes a plurality of units in one pixel and further includes a plurality of subunits in each unit. Each of the number of units in one pixel and the number of subunits may be at least two, and further, each of them may be larger than two. In this embodiment, an example in which a pixel includes a plurality of units 123 and the unit 123 further includes a plurality of subunits 123a and 123b is shown. As

an example of units provided in one pixel, an R (red) unit, a G (green) unit, and a B (blue) unit are provided in one pixel.

[0065] Display is performed using a plurality of miniaturized subunits, whereby an image can be displayed with high definition. In addition, since a liquid crystal alignment can be controlled independently in each subunit, a viewing angle can be improved.

[0066] The liquid crystal element 215a and the liquid crystal element 215b are elements which control transmission or non-transmission of light by an optical modulation action of liquid crystal. The optical modulation action of liquid crystal is controlled by an electric field applied to the liquid crystal. An electric field direction applied to the liquid crystal differs depending on a liquid crystal material, a driving method, and an electrode structure and can be selected as appropriate. For example, in the case where a driving method in which an electric field is applied in a direction of a thickness of liquid crystal (so-called a perpendicular direction) is used, a pixel electrode and a common electrode are provided on the first substrate and the second substrate, respectively, so that the liquid crystal is interposed between the pixel electrode and the common electrode. In the case where a driving method in which an electric field is applied in an in-plane direction of a substrate (so-called a horizontal direction) to liquid crystal is used, a pixel electrode and a common electrode may be provided on the same substrate side of the liquid crystal. The pixel electrode and the common electrode may have a variety of opening patterns. There is no particular limitation on a liquid crystal material, a driving method, and an electrode structure in this embodiment as long as the element controls transmission or non-transmission of light by the optical modulation action.

[0067] The subunit 123a provided in the unit 123 includes a transistor 214a functioning as a switching element, a capacitor 210a and the liquid crystal element 215a which are connected to the transistor 214a, and the subunit 123b provided in the unit 123 includes a transistor 214b functioning as a switching element, a capacitor 210b and the liquid crystal element 215b which are connected to the transistor 214b.

[0068] In this embodiment, voltages applied to the liquid crystal element 215a and the liquid crystal element 215b are different from each other, whereby alignments of liquid crystal are independently controlled in the subunit 123a and the subunit 123b. Accordingly, a wide viewing angle is achieved.

[0069] In the subunit 123a, a gate electrode of the transistor 214a is connected to the gate line 124a provided in the pixel portion 122, one of a source electrode and a drain electrode of the transistor 214a is connected to the source line 125, and the other of the source electrode and the drain electrode of the transistor 214a is connected to one of electrodes of the capacitor 210a and one of electrodes (a pixel electrode) of the liquid crystal element 215a. In the subunit 123b, a gate electrode of the transistor 214b is connected to the gate line 124b provided in the pixel portion 122, one of a source electrode and a drain electrode of the transistor 214b is connected to the source line 125, and the other of the source electrode and the drain electrode of the transistor 214b is connected to one of electrodes of the capacitor 210b and one of electrodes (a pixel electrode) of the liquid crystal element 215b. In this embodiment, the

common potential V_{com} which is a fixed potential is applied to the common electrode (electrode which faces the pixel electrode) of the liquid crystal element **215a** and the liquid crystal element **215b**, and the others of the electrodes of the capacitor **210a** and the capacitor **210b** from the power supply **116** through the display control circuit **113**.

[0070] In the subunit **123a** and the subunit **123b** of this embodiment, different potentials are supplied to the transistor **214a** and the transistor **214b** by the gate line **124a** and the gate line **124b**. Therefore, the capacitance of the capacitor **210a** and the capacitance of the capacitor **210b** are different and the voltage applied to the liquid crystal element **215a** and the voltage applied to the liquid crystal element **215b** are different from each other. Thus, in the subunit **123a** and the subunit **123b**, alignment of liquid crystal in the liquid crystal element **215a** and alignment of liquid crystal in the liquid crystal element **215b** can be controlled independently, so that a viewing angle can be improved.

[0071] In order to apply different voltages to liquid crystal elements in respective subunits, the following method also can be employed, for example: the sizes of the transistor **214a** and the transistor **214b** are different from each other, or the capacitor **210a** and the capacitor **210b** are connected to respective capacitor lines which supply different potentials from each other.

[0072] A transistor whose off current is reduced is preferably used for each of the transistor **214a** and the transistor **214b**. When the transistor **214a** and the transistor **214b** are off, electrical charges accumulated in the liquid crystal elements **215a** and **215b** and the capacitors **210a** and **210b** which are connected to the transistors **214a** and **214b** whose off currents are reduced hardly leak through the transistors **214a** and **214b**, and a state in which a signal is written before the transistors **214a** and **214b** are off can be stably held until a next signal is written. Therefore, the subunit **123a** and the subunit **123b** can be formed without using the capacitor **210a** and the capacitor **210b** which are connected to the transistor **214a** and the transistor **214b** whose off currents are reduced.

[0073] With such a structure, the capacitor **210a** and the capacitor **210b** can hold a voltage applied to the liquid crystal element **215a** and the liquid crystal element **215b**. Alternatively, the electrodes of the capacitor **210a** and the capacitor **210b** may be connected to a capacitor line additionally provided. In this case, the capacitor **210a** and the capacitor **210b** may be connected to the same capacitor line or may be connected to different capacitor lines.

[0074] The driver circuit portion **121** includes the gate line driver circuit **121A** and the source line driver circuit **121B**. The gate line driver circuit **121A** and the source line driver circuit **121B** are driver circuits for driving the pixel portion **122** including the plurality of pixels and each include a shift register circuit (also referred to as a shift register).

[0075] Note that the gate line driver circuit **121A** and the source line driver circuit **121B** may be formed over the same substrate as the pixel portion **122** or may be formed over a different substrate from the substrate where the pixel portion **122** is formed.

[0076] Note that high power supply potential V_{dd} , low power supply potential V_{ss} , a start pulse SP, a clock signal CK, and an image signal Data which are controlled by the display control circuit **113** are supplied to the driver circuit portion **121**.

[0077] A terminal portion **126** is an input terminal which supplies predetermined signals (high power supply potential V_{dd} , low power supply potential V_{ss} , a start pulse SP, a clock signal CK, an image signal Data, common potential V_{com} , and the like) which are output from the display control circuit **113**, to the driver circuit portion **121**.

[0078] The common electrode **128** is electrically connected to a common potential line which supplies common potential V_{com} controlled by the display control circuit **113** through the common connection portion.

[0079] As a specific example of the common connection portion, a conductive particle in which an insulating sphere is covered with a metal thin film is provided between the common electrode **128** and the common potential line, whereby the common electrode **128** and the common potential line can be electrically connected to each other. Note that two or more common connection portions may be provided in the display panel **120**.

[0080] In addition, the liquid crystal display device may include a photometry circuit. The liquid crystal display device provided with the photometry circuit can detect brightness of the environment where the liquid crystal display device is set. Thus, the display control circuit **113** to which the photometry circuit is connected can control a driving method of a light source such as a backlight or a sidelight in accordance with a signal input from the photometry circuit.

[0081] Note that when color display is performed, display can be performed using a color filter. In addition, another optical film (such as a polarizing film, a retardation film, or an anti-reflection film) can be used. A light source such as a backlight used for a transmissive liquid crystal display device or a transmissive liquid crystal display device may be used in accordance with usage of the liquid crystal display device **100**, and for example, a light-emitting diode (LED) or the like can be used. Further, a surface light source may be formed using a plurality of LED light sources, a plurality of electroluminescent (EL) light sources, or the like. As the surface light source, three or more kinds of LEDs may be used and an LED emitting white light may be used. Note that the color filter is not provided in the case where RGB light-emitting diodes or the like are arranged in a backlight and a successive additive color mixing method (a field sequential method) in which color display is performed by time division is employed.

[0082] Next, a structure and a driving method of a liquid crystal display device **200** are described with reference to FIG. 2. The liquid crystal display device **200** has a different structure from that of the above liquid crystal display device **100** and can achieve further low power consumption. Note that the same portions as the liquid crystal display device **100** or portions having functions similar to those of the liquid crystal display device **100** can be formed as in the liquid crystal display device **100**, and also the same steps as the liquid crystal display device **100** or the steps similar to those of the liquid crystal display device **100** can be performed in a manner similar to those of the liquid crystal display device **100**; therefore, repetitive description thereof is omitted. In addition, detailed description of the same portions is omitted.

[0083] Each component of the liquid crystal display device **200** is illustrated in a block diagram of FIG. 2. The liquid crystal display device **200** has a structure in which an image processing circuit **110** is added to the structure of the

liquid crystal display device **100**. Note that in a transmissive liquid crystal display device or a transreflective liquid crystal display device, a backlight portion **130** is provided as a light source.

[0084] The image processing circuit **110** analyzes, calculates, and processes an input image signal (image signal Data), and then outputs the processed image signal together with a control signal to the display control circuit **113**.

[0085] Specifically, the image processing circuit **110** analyzes the input image signal Data, judges whether the input image signal Data is for a moving image or a still image, and outputs a control signal including the judgment result to the display control circuit **113**. Further, the image processing circuit **110** captures a still image of one frame in the image signal Data including a moving image or a still image and outputs the captured image together with a control signal which indicates that the captured image is a still image to the display control circuit **113**. The image processing circuit **110** outputs the input image signal Data together with the above control signal to the display control circuit **113**. Note that the above-described function is an example of functions which the image processing circuit **110** has, and a variety of image processing functions may be selected in accordance with usage of the display device.

[0086] Note that since an image signal which is converted to a digital signal is easily calculated (e.g., a difference between image signals is detected), in the case where an input image signal (image signal Data) is an analog signal, an A/D converter or the like is provided in the image processing circuit **110**.

[0087] The backlight portion **130** includes a backlight control circuit **131** and a backlight **132**. The backlight **132** may be used in accordance with usage of the liquid crystal display device **200**, and a light-emitting diode (LED) or the like can be used for the backlight **132**. For example, a white light-emitting element (e.g., a white LED) can be provided in the backlight **132**. A backlight signal which controls a backlight and power supply potential are supplied from the display control circuit **113** to the backlight control circuit **131**.

[0088] Next, a driving method of the liquid crystal display device illustrated in FIG. 2 will be described with reference to FIG. 3, FIG. 4, FIGS. 5A and 5B, and FIG. 6. The driving method of the liquid crystal display device described in this embodiment is a display method in which the frequency of rewriting in the display panel varies in accordance with properties of a display image. Specifically, in the case where image signals in successive frames are different from each other (i.e., a moving image is displayed), a display mode in which an image signal is written in each frame period is used. On the other hand, in the case where image signals in successive frames have the same image (still image), used is a display mode in which writing of image signals is prevented or the writing frequency is extremely reduced in a period in which the same image is being displayed; the voltage applied to the liquid crystal element is held by setting potentials of the pixel electrode and the common electrode which apply the voltage to the liquid crystal element in a floating state; and accordingly a still image is displayed without an additional supply of potential.

[0089] The liquid crystal display device combines a moving image and a still image and performs display on the screen. Note that by switching of a plurality of different images which are time-divided into a plurality of frames at

high speed, the images are recognized as a moving image by human eyes. Specifically, by switching of images at least 60 times (60 frames) per second, the images are recognized as a moving image with fewer flickers by human eyes. In contrast, unlike a moving image and a partial moving image, a still image is an image which does not change in successive frame periods, for example, between an n-th frame and an (n+1)-th frame even though a plurality of images which are time-divided into a plurality of frame periods are switched at high speed.

[0090] The liquid crystal display device according to one embodiment of the present invention can realize different display modes which are a moving image display mode when a moving image is displayed and a still image display mode when a still image is displayed. Note that in this specification, an image displayed in a still image mode is also called a static image.

[0091] A connection between the display panel **120** and the display control circuit **113** in this embodiment is illustrated in FIG. 3.

[0092] In this embodiment, the display panel **120** includes a switching element **127** in addition to the pixel portion **122**. In this embodiment, the display panel **120** includes the first substrate and the second substrate. The driver circuit portion **121**, the pixel portion **122**, and the switching element **127** are provided over the first substrate.

[0093] In addition, the unit **123** includes the subunit **123a** and the subunit **123b**. The subunit **123a** includes the transistor **214a** functioning as a switching element, the capacitor **210a** and the liquid crystal element **215a** which are connected to the transistor **214a**, and the subunit **123b** includes the transistor **214b** functioning as a switching element, the capacitor **210b** and the liquid crystal element **215b** which are connected to the transistor **214b** (see FIG. 3).

[0094] A transistor whose off current is reduced is preferably used for each of the transistor **214a** and the transistor **214b**. When the transistor **214a** and the transistor **214b** are off, electrical charges accumulated in the liquid crystal elements **215a** and **215b** and the capacitors **210a** and **210b** which are connected to the transistors **214a** and **214b** whose off currents are reduced hardly leak through the transistors **214a** and **214b**, and a state where a signal is written before the transistor **214a** and the transistor **214b** are off can be stably held until a next signal is written.

[0095] In this embodiment, a liquid crystal is controlled by a vertical electric field generated between the pixel electrode provided over the first substrate and the common electrode provided on the second substrate which faces the first substrate.

[0096] As an example of liquid crystal applied to a liquid crystal element, the following can be given: nematic liquid crystal, cholesteric liquid crystal, smectic liquid crystal, discotic liquid crystal, thermotropic liquid crystal, lyotropic liquid crystal, low-molecular liquid crystal, polymer dispersed liquid crystal (PDLC), ferroelectric liquid crystal, anti-ferroelectric liquid crystal, main-chain liquid crystal, side-chain high-molecular liquid crystal, banana-shaped liquid crystal, and the like.

[0097] In addition, examples of a driving method of liquid crystal include a TN (twisted nematic) mode, an STN (super twisted nematic) mode, an OCB (optically compensated birefringence) mode, an ECB (electrically controlled birefringence) mode, an FLC (ferroelectric liquid crystal) mode, an AFLC (anti-ferroelectric liquid crystal) mode, a PDLC

(polymer dispersed liquid crystal) mode, a PNLC (polymer network liquid crystal) mode, a guest-host mode, and the like.

[0098] The switching element 127 supplies the common potential V_{com} to the common electrode 128 in accordance with a control signal which the display control circuit 113 outputs. As the switching element 127, a transistor can be used. A gate electrode of the transistor and one of a source electrode and a drain electrode of the transistor may be connected to the display control circuit 113 so that the common potential V_{com} is supplied from the display control circuit 113 to the one of the source electrode and the drain electrode of the transistor through the terminal portion 126. The other of the source electrode and the drain electrode of the transistor may be connected to the common electrode 128. Note that the switching element 127 may be formed over the same substrate as the driver circuit portion 121 and the pixel portion 122 or may be formed over a different substrate from the substrate where the driver circuit portion 121 and the pixel portion 122 are formed.

[0099] A transistor whose off current is reduced is used as the switching element 127, whereby a reduction over time in the voltage applied to both terminals of the liquid crystal element 215a and both terminals of the liquid crystal element 215b can be suppressed.

[0100] A terminal connected to the source electrode or the drain electrode of the switching element 127 and the common electrode 128 are electrically connected to each other through the common connection portion.

[0101] One of the source electrode and the drain electrode of the switching element 127 for which a transistor as one embodiment of the switching element is used is connected to a terminal 126B, and the other of the source electrode and the drain electrode of the switching element 127 is connected through the common connection portion to the other electrodes of the capacitors 210a and 210b and the other electrodes of the liquid crystal elements 215a and 215b which are not connected to the transistors 214a and 214b, respectively. Further, a gate electrode of the switching element 127 is connected to a terminal 126A.

[0102] Next, signals supplied to the pixels are described with reference to an equivalent circuit diagram of the liquid crystal display device illustrated in FIG. 3 and a timing chart shown in FIG. 4.

[0103] A clock signal GCK and a start pulse GSP which the display control circuit 113 supplies to the gate line driver circuit 121A are shown in FIG. 4. In addition, a clock signal SCK and a start pulse SSP which the display control circuit 113 supplies to the source line driver circuit 121B are shown in FIG. 4. Note that waveform of the clock signal is shown in simple rectangular waves in FIG. 4 in order to describe timings of outputting the clock signals.

[0104] Further, high power supply potential V_{dd} , potential of the source line 125 (potential of a Data line), potential of the pixel electrode, potential of the terminal 126A, potential of the terminal 126B, and potential of the common electrode are shown in FIG. 4.

[0105] In FIG. 4, a period 1401 corresponds to a period in which image signals for displaying a moving image are written. In the period 1401, image signals and common potential are supplied to each pixel of the pixel portion 122 and the common electrode.

[0106] Further, a period 1402 corresponds to a period in which a still image is displayed. In the period 1402, the

supply of image signals to each pixel of the pixel portion 122 and the common potential to the common electrode is stopped. Note that FIG. 4 shows that each signal is supplied so that the driver circuit portion stops operating in the period 1402; however, it is preferable to prevent deterioration of a still image by writing image signals periodically in accordance with the length of the period 1402 and the refresh rate.

[0107] First, a timing chart in the period 1401 is described. In the period 1401, a clock signal is always supplied as the clock signal GCK and a pulse corresponding to vertical synchronization frequency is supplied as the start pulse GSP. Moreover, in the period 1401, a clock signal is always supplied as the clock signal SCK and a pulse corresponding to one gate selection period is supplied as the start pulse SSP.

[0108] The image signal Data is supplied to the pixels in each row through the source line 125 and potential of the source line 125 is supplied to the pixel electrode in accordance with potential of the gate line 124.

[0109] The display control circuit 113 supplies potential which brings the switching element 127 into electrical conduction to the terminal 126A of the switching element 127 and common potential to the common electrode through the terminal 126B.

[0110] On the other hand, the period 1402 is a period in which a still image is displayed. A timing chart in the period 1402 is described. In the period 1402, the supply of the clock signal GCK, the start pulse GSP, the clock signal SCK, and the start pulse SSP is stopped. Further, in the period 1402, the supply of the image signal Data to the source line 125 is stopped. In the period 1402 in which the supply of the clock signal GCK and the start pulse GSP is stopped, the transistor 214a and the transistor 214b are brought out of electrical conduction and the potential of the pixel electrode becomes in a floating state.

[0111] In addition, the display control circuit 113 supplies potential to the terminal 126A of the switching element 127 to bring the switching element 127 out of electrical conduction, so that the potential of the common electrode becomes in a floating state.

[0112] In the period 1402, the potential of both terminals of the liquid crystal element 215a and both terminals of the liquid crystal element 215b, that is, the pixel electrode and the common electrode, becomes in a floating state, so that a still image can be displayed without additional potential supply.

[0113] The supply of a clock signal and a start pulse to the gate line driver circuit 121A and the source line driver circuit 121B is stopped, so that low power consumption can be achieved.

[0114] In particular, a transistor whose off current is reduced is used for each of the transistor 214a, the transistor 214b, and the switching element 127, whereby a reduction over time in the voltage applied to both terminals of the liquid crystal element 215a and both terminals of the liquid crystal element 215b can be suppressed.

[0115] Next, operation of the display control circuit in a period in which a displayed image is switched to a still image from a moving image (a period 1403 in FIG. 4) and in a period in which a displayed image is switched to a moving image from the still image (a period 1404 in FIG. 4) is described with reference to FIGS. 5A and 5B. FIGS. 5A and 5B show high power supply potential V_{dd} , a clock signal

(here, GCK), a start pulse signal (here, GSP), and potential of the terminal 126A which the display control circuit outputs.

[0116] The operation of the display control circuit in the period 1403 in which the displayed image is switched to the still image to the moving image is shown in FIG. 5A. The display control circuit stops the supply of the start pulse GSP (E1 in FIG. 5A, a first step). Next, the supply of a plurality of clock signals GCK is stopped after the pulse output reaches the last stage of the shift register (E2 in FIG. 5A, a second step). Next, the power supply voltage is changed from the high power supply potential V_{dd} to the low power supply potential V_{ss} (E3 in FIG. 5A, a third step). Next, the potential of the terminal 126A is changed to potential which brings the switching element 127 out of electrical conduction (E4 in FIG. 5A, a fourth step).

[0117] Through the above steps, the supply of the signals to the driver circuit portion 121 can be stopped without a malfunction of the driver circuit portion 121. Since a malfunction generated when the displayed image is switched to a still image to a moving image causes a noise and the noise is held as a still image, a liquid crystal display device mounted with a display control circuit with less malfunctions can display a still image with less image deterioration.

[0118] Next, the operation of the display control circuit in the period 1404 in which the displayed image is switched to the moving image from the still image is described with reference to FIG. 5B. The display control circuit changes the potential of the terminal 126A into a potential at which the switching element 127 is turn on (S1 in FIG. 5B, a first step). Next, the power supply voltage is changed from the low power supply potential V_{ss} to the high power supply potential V_{dd} (S2 in FIG. 5B, a second step). After high potential is applied, a plurality of clock signals GCK are supplied (S3 in FIG. 5B, a third step). Next, the start pulse signal GSP is supplied (S4 in FIG. 5B, a fourth step).

[0119] Through the above steps, the supply of driving signals to the driver circuit portion 121 can restart without a malfunction of the driver circuit portion 121. When potentials of wirings are sequentially changed back to those at the time of displaying a moving image, the driver circuit portion can be driven without a malfunction.

[0120] In addition, the frequency of writing image signals in the period 601 in which a moving image is displayed and the period in which a still image is displayed is schematically shown in FIG. 6. In FIG. 6, "W" indicates a period in which an image signal is written, and "H" indicates a period in which the image signal is held. In addition, a period 603 indicates one frame period; however, the period 603 may be a different period.

[0121] As described above, in the liquid crystal display device of this embodiment, an image signal of a still image displayed in the period 602 is written in a period 604, and the image signal written in the period 604 is held in the periods which are other than the period 604 of the period 602.

[0122] Next, a structure of the image processing circuit 110 and a procedure in which the image processing circuit 110 processes signals are described with reference to FIG. 7 as an example. Note that the image processing circuit 110 illustrated in FIG. 7 is just one of embodiments and this embodiment is not limited to this structure.

[0123] The image processing circuit 110 illustrated in FIG. 7 analyzes image signals which are successively input and

judges whether the input image signal is for a moving image or a still image. When the inputted image signal (image signal Data) is switched from a moving image signal to a still image signal, the image processing circuit 110 captures a still image and outputs the captured image together with a control signal which indicates that the captured image is a still image to the display control circuit 113. When the inputted image signal (image signal Data) is changed from a still image signal to a moving image signal, the image processing circuit 110 outputs an image signal including a moving image together with a control signal which indicates that the image signal is a moving image to the display control circuit 113.

[0124] The image processing circuit 110 illustrated in FIG. 7 includes a memory circuit 111, a comparison circuit 112, and a selection circuit 115. The image processing circuit 110 generates a display panel image signal and a backlight signal from an input digital image signal Data. The display panel image signal is an image signal which controls the display panel 120 and the backlight signal is a signal which controls the backlight portion 130.

[0125] The memory circuit 111 includes a plurality of frame memories for storing image signals of a plurality of frames. There is no particular limitation on the number of frame memories included in the memory circuit 111 as long as the image signals of a plurality of frames can be stored. Note that the frame memory may be formed using a memory element such as a dynamic random access memory (DRAM) or a static random access memory (SRAM).

[0126] Note that the number of frame memories is not particularly limited to a certain number as long as each frame memory stores an image signal for one frame period. Further, the image signals stored in the frame memories are selectively read by the comparison circuit 112 and the display control circuit 113. Note that a frame memory 111b in the drawing is schematically illustrated as a memory region of one frame.

[0127] The comparison circuit 112 is a circuit which selectively reads out image signals in successive frame periods stored in the memory circuit 111, compares the image signals in of the successive frames in each pixel, and detects a difference thereof.

[0128] Note that in this embodiment, operation of the display control circuit 113 and the selection circuit 115 is determined depending on whether or not a difference between image signals is detected in of the successive frames. In the case where the comparison circuit 112 detects a difference in any pixel between frames (in the case a difference is detected), the comparison circuit 112 determines that the image signals are not for displaying a still image and that the image signals of the successive frame periods in which a difference is detected are for a moving image.

[0129] On the other hand, in the case where a difference is not detected in all pixels by the comparison between image signals by the comparison circuit 112 (in the case of no difference is detected), the comparison circuit 112 determines that images of the successive frame periods in which a difference is not detected are for a still image. That is, the comparison circuit 112 determines whether image signals in a successive frame periods are image signals for displaying a moving image or image signals for displaying a still image by detecting whether or not there is a difference between the image signals.

[0130] Note that the criterion of determining that there is a difference by the comparison may be set such a condition that the difference is recognized when the difference exceeds a predetermined level. Note that a difference detected by the comparison circuit 112 may be determined by the absolute value of the difference.

[0131] Further, in this embodiment, the structure is described in which whether the image is a moving image or a still image is determined by detection of a difference between image signals in a successive frame periods by the comparison circuit 112 provided in the liquid crystal display device 200; however, a structure in which a signal indicating whether an image is a moving image or a still image may be supplied from the outside.

[0132] The selection circuit 115 includes a plurality of switches, for example, switches formed using transistors. In the case where the comparison circuit 112 detects a difference in successive frames, that is, in the case where an image is a moving image, the selection circuit 115 selects an image signal of a moving image from frame memories in the memory circuit 111 and outputs the image signals to the display control circuit 113.

[0133] Note that in the case where the comparison circuit 112 does not detect a difference in successive frames, that is, in the case where an image is a still image, the selection circuit 115 does not output an image signal from frame memories in the memory circuit 111 to the display control circuit 113. Image signals are not output from the frame memories to the display control circuit 113, whereby power consumption of the liquid crystal display device can be reduced.

[0134] Note that in the liquid crystal display device of this embodiment, a mode performed in such a way that the comparison circuit 112 determines the image signal as a still image is described as a still image display mode, and a mode performed in such a way that the comparison circuit 112 determines the image signal as a moving image is described as a moving image display mode.

[0135] As described above, with the use of the image processing circuit 110 illustrated in FIG. 7, whether an input image signal Data is for a moving image or a still image is determined and a control signal including a judgement result is output to the display control circuit 113. Further, the image processing circuit 110 can capture a still image of one frame from the image signal Data including a moving image or a still image and can output the still image together with a control signal which indicates that the captured image is a still image to the display control circuit 113. Furthermore, the image processing circuit 110 can output the input image signal Data together with the above control signal to the display control circuit 113.

[0136] In addition, the display control circuit 113 which receives the control signal which indicates a still image from the image processing circuit 110 can reduce the frequency of writing image signals in a period in which a still image is displayed. As a result, low power consumption while a still image is being displayed can be achieved.

[0137] In the case where a still image is displayed by rewriting the same image a plurality of times, switching of images can be seen, which might cause eye strain. In the liquid crystal display device of this embodiment, the frequency of writing image signals is reduced, whereby there is an effect of reducing eye strain.

[0138] Specifically, by using transistors whose off currents are reduced for each pixel and a switching element of the common electrode, the liquid crystal display device of this embodiment can provide a long period (time) of holding a voltage in a storage capacitor. As a result, the frequency of writing image signals can be especially reduced, so that consumed power at the time of displaying a still image and eye strain can be significantly reduced.

Embodiment 2

[0139] In this embodiment, an example of an electronic device including the liquid crystal display device described in Embodiment 1 will be described.

[0140] FIG. 8A illustrates an external view of a television receiver which is an electronic device. FIG. 8A illustrates a housing 700 in which a display module 701 manufactured using the display panel described in Embodiment 1 is provided. The housing 700 includes a speaker 702, operation keys 703, an external connection terminal 704, an illumination sensor 705, and the like.

[0141] The television receiver illustrated in FIG. 8A can display text information or a still image in addition to a moving image. A moving image can be displayed in a region of a display portion while a still image can be displayed in the other region. Note that a still image displayed includes characters, diagrams, signs, pictures, designs, and paintings or a combination of any of them. Alternatively, any of the displayed images which are colored is included.

[0142] FIG. 8B shows a block diagram of a main structure of the television receiver. A television receiver 710 illustrated in FIG. 8B includes a tuner 711, a digital demodulation circuit 712, a video signal processing circuit 713, an audio signal processing circuit 714, a display adjusting circuit 715, a display control circuit 716, a display panel 717, a gate line driver circuit 718, a source line driver circuit 719, a speaker 720, and an image processing circuit 724.

[0143] The tuner 711 receives a video signal and an audio signal from an antenna 721. The digital demodulation circuit 712 demodulates a signal from the tuner 711 to a video signal and an audio signal of a digital signal. The video signal processing circuit 713 converts a video signal of a digital signal into a color signal corresponding to each color: red, green, and blue. The audio signal processing circuit 714 performs conversion of an audio signal of a digital signal into a signal which is output as the sound from the speaker 720, and the like. The display adjusting circuit 715 receives control information of a receiving station (receiving frequency) and sound volume from an external input portion 722 and transmits the signal to the tuner 711 or the audio signal processing circuit 714.

[0144] The display control circuit 716, the display panel 717, the gate line driver circuit 718, the source line driver circuit 719, and the image processing circuit 724 correspond to the display control circuit 113, the display panel 120, the gate line driver circuit 121A, the source line driver circuit 121B, and the image processing circuit 110 described in Embodiment 1 respectively. That is, a dotted line portion 723 has a structure corresponding to the liquid crystal display device 200 described in Embodiment 1. Note that the video signal processing circuit 713 may also serve as the display control circuit 716 and the image processing circuit 724. Therefore, the frequency of rewriting image signals can be reduced, and there is an effect that a flicker due to rewriting is reduced and eye strain is reduced.

[0145] Next, FIG. 9A illustrates an external view of a monitor (also referred to as a PC monitor) used for an electronic calculator (a personal computer) which is an electronic device. FIG. 9A illustrates a housing 800 in which a display module 801 manufactured using the display panel described in Embodiment 1 is provided. The housing 800 includes a speaker 802, an external connection terminal 803, and the like. Note that in FIG. 9A, a window-type display portion 804 is illustrated to indicate that the monitor is a PC monitor.

[0146] In FIG. 9A, a main structure of a PC monitor of a so-called desktop computer is illustrated but the PC monitor may also be a PC monitor of a laptop computer. Note that a display of the PC monitor includes still images such as characters, diagrams, signs, pictures, designs, and paintings or a combination any of them, or any of the still images which are colored, in addition to moving images.

[0147] A block diagram of a main structure of a PC monitor is illustrated in FIG. 9B. A PC monitor 810 illustrated in FIG. 9B includes a video signal processing circuit 813, an audio signal processing circuit 814, a display control circuit 816, a display panel 817, a gate line driver circuit 818, a source line driver circuit 819, a speaker 820, and an image processing circuit 824.

[0148] The video signal processing circuit 813 converts a video signal from an external arithmetic circuit 821 such as a CPU into a color signal corresponding to each color: red, green, and blue. The audio signal processing circuit 814 performs conversion of an audio signal from the external arithmetic circuit 821 such as a CPU into a signal which is output as the sound from the speaker 820, and the like. A signal output from the video signal processing circuit 813 and the audio signal processing circuit 814 varies according to operation by an external operation means 822 such as a keyboard.

[0149] The display control circuit 816, the display panel 817, the gate line driver circuit 818, the source line driver circuit 819, and the image processing circuit 824 correspond to the display control circuit 113, the display panel 120, the gate line driver circuit 121A, the source line driver circuit 121B, and the image processing circuit 110 described in Embodiment 1 respectively. That is, a dotted line portion 823 has a structure corresponding to the liquid crystal display device 200 described in Embodiment 1. Note that the video signal processing circuit 813 and the image processing circuit 824 may also serve as the display control circuit 816. Therefore, the frequency of rewriting image signals can be reduced, and there is an effect that a flicker due to rewriting is reduced and eye strain is reduced.

[0150] This embodiment can be implemented in appropriate combination with any of the structures described in the other embodiments.

Embodiment 3

[0151] In this embodiment, description is made on a structure example of a backlight (a backlight portion, a backlight unit) which can be applied to a liquid crystal display device disclosed in this specification with reference to FIGS. 10A to 10C and FIGS. 11A to 11C.

[0152] FIG. 10A illustrates an example of a liquid crystal display device including a so-called edge-light type backlight portion 5201 and a display panel 5207. An edge-light type corresponds to a type in which a light source is

provided at an end of a backlight portion and light of the light source is emitted from the entire light-emitting surface.

[0153] The backlight portion 5201 includes a diffusion plate 5202 (also referred to as a diffusion sheet), a light guide plate 5203, a reflection plate 5204, a lamp reflector 5205, and a light source 5206. Note that the backlight portion 5201 may also include a luminance improvement film or the like.

[0154] The light source 5206 has a function of emitting light as necessary. For example, for the light source 5206, a cold cathode fluorescent lamp (CCFL), a light emitting diode, an EL element, or the like is used.

[0155] FIG. 10B is a diagram illustrating a detailed structure of an edge-light type backlight portion. Note that description of a diffusion plate, a light guide plate, a reflection plate, and the like is omitted.

[0156] A backlight portion 5201 illustrated in FIG. 10B has a structure in which light-emitting diodes (LEDs) 5223 are used as light sources. For example, the light-emitting diodes (LEDs) 5223 which emit white light are provided at a predetermined interval. In addition, a lamp reflector 5222 is provided to reflect light from the light-emitting diodes (LEDs) 5223 efficiently. Note that in the case where display is performed in combination with a field-sequential method, light-emitting diodes (LEDs) of each color of RGB may be used as light sources.

[0157] FIG. 10C shows an example of a liquid crystal display device including a so-called direct-type backlight portion and a liquid crystal panel. A direct type corresponds to a type in which a light source is provided directly under a light-emitting surface and light of the light source is emitted from the entire light-emitting surface.

[0158] A backlight portion 5290 includes a diffusion plate 5291, a light-shielding portion 5292, a lamp reflector 5293, a light source 5294, and a liquid crystal panel 5295.

[0159] The light source 5294 has a function of emitting light as necessary. For example, for the light source 5294, a cold cathode fluorescent lamp, a light-emitting diode, an EL element which is a light-emitting element (e.g., an organic electroluminescence element), or the like is used.

[0160] Note that in the so-called direct-type backlight portion, the thickness of the backlight portion can be reduced with use of an EL element which is a light-emitting element as a light source. An example of a backlight portion using an EL element is illustrated in FIG. 11A.

[0161] A backlight portion 5290 illustrated in FIG. 11A includes an EL element 1025 provided over a substrate 1020. The EL element 1025 has a structure in which an EL layer 1003 including a light-emitting region is sandwiched between a pair of electrodes (an anode 1001 and a cathode 1002). Note that a substrate, a film, a protective film, or the like may be provided to cover the EL element 1025 so that the EL element 1025 may be sealed.

[0162] In this embodiment, since light from the EL layer 1003 is emitted to the display panel 5207 through the anode 1001, the anode 1001 may include a material which emits light such as an indium tin oxide (ITO). The cathode 1002 may include a material which reflects light such as an aluminum film. At least one of the anode 1001 and the cathode 1002 may have light-emitting properties.

[0163] Examples of element structures of the EL element 1025 in FIG. 11A are illustrated in FIGS. 11B and 11C.

[0164] The EL layer 1003 may include at least a light-emitting layer 1013, and may have a stacked-layer structure including a functional layer other than the light-emitting

layer **1013**. As the functional layer other than the light-emitting layer **1013**, a layer containing a substance having a high hole-injection property, a substance having a high hole-transport property, a substance having a high electron-transport property, a substance having a high electron-injection property, a bipolar substance (a substance having high electron and hole transport properties), or the like can be used. Specifically, functional layers such as a hole-injection layer **1011**, a hole-transport layer **1012**, the light-emitting layer **1013**, an electron-transport layer **1014**, and an electron-injection layer **1015** can be used as appropriate in combination.

[0165] Next, materials that can be used for the above-described EL element **1025** are specifically described.

[0166] The anode **1001** is preferably made of a metal, an alloy, an electrically conductive compound, a mixture thereof, or the like that has a high work function (specifically, a work function of 4.0 eV or higher is preferable). Specifically, for example, conductive metal oxide such as indium oxide-tin oxide (ITO: indium tin oxide), indium oxide-tin oxide containing silicon or silicon oxide, indium oxide-zinc oxide (IZO: indium zinc oxide), or indium oxide containing tungsten oxide and zinc oxide can be given.

[0167] Films of these conductive metal oxides are usually formed by sputtering; however, a sol-gel method or the like may also be used. For example, indium oxide-zinc oxide (IZO) can be formed by a sputtering method using indium oxide into which zinc oxide of 1 wt % to 20 wt % is added, as a target. Indium oxide containing tungsten oxide and zinc oxide can be formed by a sputtering method using indium oxide into which tungsten oxide of 0.5 wt % to 5 wt % and zinc oxide of 0.1 wt % to 1 wt % are added, as a target.

[0168] Besides, as a material used for the anode **1001**, it is also possible to use gold (Au), platinum (Pt), nickel (Ni), tungsten (W), chromium (Cr), molybdenum (Mo), iron (Fe), cobalt (Co), copper (Cu), palladium (Pd), titanium (Ti), nitride of a metal material (such as titanium nitride), molybdenum oxide, vanadium oxide, ruthenium oxide, tungsten oxide, manganese oxide, titanium oxide, or the like.

[0169] The cathode **1002** can be made of a metal, an alloy, an electrically conductive compound, a mixture thereof, or the like that has a low work function (specifically, a work function lower than or equal to 3.8 eV is preferable). As a specific example of such a cathode material, an element belonging to Group 1 or Group 2 in the periodic table, i.e., an alkali metal such as lithium (Li) or cesium (Cs), or an alkaline earth metal such as magnesium (Mg), calcium (Ca), or strontium (Sr); an alloy containing any of these (such as MgAg or AlLi); a rare earth metal such as europium (Eu) or ytterbium (Yb); an alloy containing any of such a rare earth metal; or the like can be used. Note that a film of an alkali metal, an alkaline earth metal, or an alloy thereof can be formed by a vacuum evaporation method. An alloy containing an alkali metal or an alkaline earth metal can also be formed by a sputtering method. Further, a silver paste or the like can be formed by an inkjet method or the like.

[0170] In addition, the cathode **1002** can be formed by a stack of a thin film of an alkali metal compound, an alkaline earth metal compound, or a rare earth metal compound (e.g., lithium fluoride (LiF), lithium oxide (LiO_x), cesium fluoride (CsF), calcium fluoride (CaF₂), or erbium fluoride (ErF₃)) and a film of a metal such as aluminum.

[0171] Next, specific examples of materials used for forming each of layers included in the EL layer **1003** are described below.

[0172] The hole-injection layer **1011** is a layer including a substance having a high hole-injection property. As the substance having a high hole-injection property, for example, molybdenum oxide, vanadium oxide, ruthenium oxide, tungsten oxide, manganese oxide, or the like can be used. Alternatively, the hole-injection layer **1011** can be formed using a phthalocyanine-based compound such as phthalocyanine (abbreviation: H₂Pc) or copper phthalocyanine (abbreviation: CuPc); an aromatic amine compound such as 4,4'-bis[N-(4-diphenylaminophenyl)-N-phenylamino]biphenyl (abbreviation: DPAB) or N,N'-bis[4-[bis(3-methylphenyl)amino]phenyl]-N,N'-diphenyl-[1,1'-biphenyl]-4,4'-diamine (abbreviation: DNTPD); a high molecule such as poly(3,4-ethylenedioxythiophene)/poly(styrenesulfonic acid)(PEDOT/PSS), or the like. Further, the hole-injection layer **1011** can be formed using a tris(p-enamine-substituted-aminophenyl)amine compound, a 2,7-diamino-9-fluorenylidene compound, a tri(p-N-enamine-substituted-aminophenyl) benzene compound, a pyrene compound having one or two ethenyl groups having at least one aryl group, N,N'-di(biphenyl-4-yl)-N,N'-diphenylbiphenyl-4,4'-diamine, N,N,N',N'-tetra(biphenyl-4-yl)biphenyl-4,4'-diamine, N,N,N',N'-tetra(biphenyl-4-yl)-3,3'-diethylbiphenyl-4,4'-diamine, 2,2'-(methylenedi-4,1-phenylene)bis[4,5-bis(4-methoxyphenyl)-2H-1,2,3-triazole], 2,2'-(biphenyl-4,4'-diyl)bis(4,5-diphenyl-2H-1,2,3-triazole), 2,2'-(3,3'-dimethylbiphenyl-4,4'-diyl)bis(4,5-diphenyl-2H-1,2,3-triazole), bis[4-(4,5-diphenyl-2H-1,2,3-triazol-2-yl)phenyl] (methyl)amine, or the like.

[0173] The hole-injection layer **1011** can also be formed of a hole-injection composite material including an organic compound and an inorganic compound (preferably, an inorganic compound having an electron-accepting property to an organic compound). Since electrons are transferred between the organic compound and the inorganic compound, the hole-injection composite material has a high carrier density, and thus has an excellent hole-injection property and a hole-transport property.

[0174] In the case where the hole-injection layer **1011** is made of a hole-injection composite material, the hole-injection layer **1011** can form an ohmic contact with the anode **1001**; thus, the material of the anode **1001** can be selected regardless of the work function.

[0175] The inorganic compound used for the hole-injection composite material is preferably an oxide of a transition metal. In addition, an oxide of metals that belong to Group 4 to Group 8 in the periodic table can be given. Specifically, vanadium oxide, niobium oxide, tantalum oxide, chromium oxide, molybdenum oxide, tungsten oxide, manganese oxide, and rhenium oxide are preferable since their electron-accepting properties are high. Among them, use of molybdenum oxide is especially preferable since it is stable in the air, has a low hygroscopic property, and is easily treated.

[0176] As the organic compound used for the hole-injection composite material, it is possible to use various compounds such as an aromatic amine compound, a carbazole derivative, an aromatic hydrocarbon, and a high molecular compound (oligomer, dendrimer, polymer, or the like). Note that the organic compound used for the hole-injection composite material is preferably an organic compound with a high hole-transport property. Specifically, a substance hav-

ing a hole mobility greater than or equal to 10^{-6} cm²/Vs is preferably used. Note that substances other than the above described materials may also be used as long as the substances in which a hole-transport property is higher than an electron-transport property. The organic compounds that can be used for the hole-injection composite material are specifically described below.

[0177] As aromatic amine compounds, for example, there are N,N'-di(p-tolyl)-N,N'-diphenyl-p-phenylenediamine (abbreviation: DTDPPA), 4,4'-bis[N-(4-diphenylaminophenyl)-N-phenylamino]biphenyl (abbreviation: DPAB), N,N'-bis[4-[bis(3-methylphenyl)amino]phenyl]-N,N'-diphenyl-[1,1'-biphenyl]-4,4'-diamine (abbreviation: DNTPD), 1,3,5-tris[N-(4-diphenylaminophenyl)-N-phenylamino]benzene (abbreviation: DPA3B), and the like.

[0178] Specific examples of the carbazole derivative used for the hole-injection composite material include: 3-[N-(9-phenylcarbazol-3-yl)-N-phenylamino]-9-phenylcarbazole (abbreviation: PCzPCA1); 3,6-bis[N-(9-phenylcarbazol-3-yl)-N-phenylamino]-9-phenylcarbazole (abbreviation: PCzPCA2); 3-[N-(1-naphthyl)-N-(9-phenylcarbazol-3-yl)amino]-9-phenylcarbazole (abbreviation: PCzPCN1); and the like.

[0179] Moreover, 4,4'-di(N-carbazolyl)biphenyl (abbreviation: CBP); 1,3,5-tris[4-(N-carbazolyl)phenyl]benzene (abbreviation: TCPB); 9-[4-(N-carbazolyl)]phenyl-10-phenylanthracene (abbreviation: CzPA); 1,4-bis[4-(N-carbazolyl)phenyl]-2,3,5,6-tetraphenylbenzene; or the like can also be used.

[0180] Examples of the aromatic hydrocarbon used for the hole-injection composite material include: 2-tert-butyl-9,10-di(2-naphthyl)anthracene (abbreviation: t-BuDNA); 2-tert-butyl-9,10-di(1-naphthyl)anthracene; 9,10-bis(3,5-diphenylphenyl)anthracene (abbreviation: DPPA); 2-tert-butyl-9,10-bis(4-phenylphenyl)anthracene (abbreviation: t-BuDBA); 9,10-di(2-naphthyl)anthracene (abbreviation: DNA); 9,10-diphenylanthracene (abbreviation: DPAnth); 2-tert-butylanthracene (abbreviation: t-BuAnth); 9,10-bis(4-methyl-1-naphthyl)anthracene (abbreviation: DMNA); 2-tert-butyl-9,10-bis[2-(1-naphthyl)phenyl]anthracene; 9,10-bis[2-(1-naphthyl)phenyl]anthracene; 2,3,6,7-tetramethyl-9,10-di(1-naphthyl)anthracene; 2,3,6,7-tetramethyl-9,10-di(2-naphthyl)anthracene; 9,9'-bianthryl; 10,10'-diphenyl-9,9'-bianthryl; 10,10'-bis(2-phenylphenyl)-9,9'-bianthryl; 10,10'-bis[(2,3,4,5,6-pentaphenyl)phenyl]-9,9'-bianthryl; anthracene; tetracene; rubrene; perylene; 2,5,8,11-tetra(tert-butyl)perylene; and the like. Besides those, pentacene, coronene, or the like can also be used. In particular, the aromatic hydrocarbon having a hole mobility greater than or equal to 1×10^{-6} cm²/Vs and having 14 to 42 carbon atoms is particularly preferable.

[0181] Note that the aromatic hydrocarbon used for the hole-injection composite material may have a vinyl skeleton. As the aromatic hydrocarbon having a vinyl group, the following are given for example: 4,4'-bis(2,2-diphenylvinyl)biphenyl (abbreviation: DPVBi); 9,10-bis[4-(2,2-diphenylvinyl)phenyl]anthracene (abbreviation: DPVPA); and the like.

[0182] In addition, a high molecular compound such as poly(N-vinylcarbazole) (abbreviation: PVK) or poly(-vinyltriphenylamine) (abbreviation: PVTPA) can also be used.

[0183] The hole-transport layer **1012** includes a substance having a high hole-transport property. As the substance having a high hole-transport property, for example, an

aromatic amine compound (that is, a compound having a benzene ring-nitrogen bond) is preferable. As examples of the material which are widely used, the following can be given: 4,4'-bis[N-(3-methylphenyl)-N-phenylamino]biphenyl; a derivative thereof such as 4,4'-bis[N-(1-naphthyl)-N-phenylamino]biphenyl (hereinafter referred to as NPB); and a starburst aromatic amine compound such as 4,4',4''-tris(N,N-diphenyl-amino)triphenylamine, 4,4',4''-tris[N-(3-methylphenyl)-N-phenylamino]triphenylamine, and the like. The substances mentioned here are mainly ones that have a hole mobility higher than or equal to 10^{-6} cm²/Vs. Note that substances other than the above described materials may also be used as long as the substances have a higher hole-transport property than an electron-transport property. The hole-transport layer **1012** is not limited to a single layer, and may be a mixed layer of the aforementioned substances or a stacked layer of two or more layers each including the aforementioned substance.

[0184] Alternatively, a material with a hole-transport property may be added to a high molecular compound that is electrically inactive, such as PMMA.

[0185] Further alternatively, a high molecular compound such as poly(N-vinylcarbazole) (abbreviation: PVK), poly(-vinyltriphenylamine) (abbreviation: PVTPA), poly[N-(4-{4-(4-diphenylamino)phenyl}phenyl)-N'-phenylamino]phenylmethacrylamide (abbreviation: PTPDMA), or poly[N,N'-bis(4-butylphenyl)-N,N'-bis(phenyl)benzidine (abbreviation: Poly-TPD) may be used, and further, the material with a hole-transport property may be added to the above high molecular compound, as appropriate. Further, the hole-transport layer **1012** can be formed using a tris(p-enamine-substituted-aminophenyl)amine compound, a 2,7-diamino-9-fluorenylidene compound, a tri(p-N-enamine-substituted-aminophenyl)benzene compound, a pyrene compound having one or two ethenyl groups having at least one aryl group, N,N'-di(biphenyl-4-yl)-N,N'-diphenylbiphenyl-4,4'-diamine, N,N,N',N'-tetra(biphenyl-4-yl)biphenyl-4,4'-diamine, N,N,N',N'-tetra(biphenyl-4-yl)-3,3'-diethylbiphenyl-4,4'-diamine, 2,2'-(methylenedi-4,1-phenylene)bis[4,5-bis(4-methoxyphenyl)-2H-1,2,3-triazole], 2,2'-(biphenyl-4,4'-diyl)bis(4,5-diphenyl-2H-1,2,3-triazole), 2,2'-(3,3'-dimethylbiphenyl-4,4'-diyl)bis(4,5-diphenyl-2H-1,2,3-triazole), bis[4-(4,5-diphenyl-2H-1,2,3-triazol-2-yl)phenyl](methyl)amine, or the like.

[0186] The light-emitting layer **1013** is a layer including a light-emitting substance and can be formed using a variety of materials. For example, as a light-emitting substance, a fluorescent compound which emits fluorescence or a phosphorescent compound which emits phosphorescence can be used. Organic compound materials which can be used for the light-emitting layer are described below. Note that materials which can be used for the EL element **1025** are not limited to these materials.

[0187] Blue to blue-green light emission can be obtained, for example, by using perylene, 2,5,8,11-tetra-tert-butylperylene (abbreviation: TBP), 9,10-diphenylanthracene, or the like as a guest material, and dispersing the guest material in a suitable host material. Alternatively, the blue to blue-green light emission can be obtained from a styrylarylene derivative such as 4,4'-bis(2,2-diphenylvinyl)biphenyl (abbreviation: DPVBi), or an anthracene derivative such as 9,10-di-2-naphthylanthracene (abbreviation: DNA) or 9,10-bis(2-naphthyl)-2-tert-butylanthracene (abbreviation:

t-BuDNA). Further, a polymer such as poly(9,9-dioctylfluorene) may be used. Further, as a guest material for blue light emission, a styrylamine derivative is preferable. Examples which can be given include N,N'-bis[4-(9H-carbazol-9-yl)phenyl]-N,N'-diphenylstilbene-4,4'-diamine (abbreviation: YGA2S), N,N'-diphenyl-N,N'-bis(9-phenyl-9H-carbazol-3-yl)stilbene-4,4'-diamine (abbreviation: PCA2S), and the like. In particular, YGA2S is preferable because it has a peak at around 450 nm. Further, as a host material, an anthracene derivative is preferable; 9,10-bis(2-naphthyl)-2-t-butylanthracene (abbreviation: t-BuDNA) or 9-[4-(10-phenyl-9-anthryl)phenyl]-9H-carbazole (abbreviation: CzPA) is suitable. In particular, CzPA is preferable because it is electrochemically stable.

[0188] Blue-green to green light emission can be obtained, for example, by using a coumarin dye such as coumarin 30 or coumarin 6, bis[2-(2,4-difluorophenyl)pyridinato]picolinatoiridium (abbreviation: Flrpic), bis(2-phenylpyridinato)acetylacetonatoiridium (abbreviation: Ir(ppy)₂(acac)), or the like as a guest material and dispersing the guest material in a suitable host material. Further, blue-green to green light emission can be obtained by dispersing perylene or TBP, which are mentioned above, in a suitable host material at a high concentration greater than or equal to 5 wt %. Further alternatively, the blue-green to green light emission can be obtained from a metal complex such as BA1q, Zn(BTZ)₂, or bis(2-methyl-8-quinolinolato)chlorogallium (Ga(mq)₂Cl). Further, a polymer such as poly(p-phenylenevinylene) may be used. An anthracene derivative is preferable as a guest material of a blue-green to green light-emitting layer, as high light-emitting efficiency can be obtained when an anthracene derivative is used. For example, when 9,10-bis{4-[N-(4-diphenylamino)phenyl-N-phenyl]aminophenyl}-2-tert-butylanthracene (abbreviation: DPABPA) is used, highly efficient blue-green light emission can be obtained. In addition, an anthracene derivative in which an amino group has been substituted into the 2-position is preferable, as highly efficient green light emission can be obtained with such an anthracene derivative. In particular, N-(9,10-diphenyl-2-anthryl)-N,9-diphenyl-9H-carbazol-3-amine (abbreviation: 2PCAPA) is suitable, as it has a long life. As a host material for these materials, an anthracene derivative is preferable; CzPA, which is mentioned above, is preferable, as it is electrochemically stable. In the case where the EL element **1025** having two peaks in the blue to green wavelength range is manufactured by combining green light emission and blue light emission, an anthracene derivative having an electron-transport property, such as CzPA, is preferably used as a host material for a blue-light-emitting layer and an aromatic amine compound having a hole-transport property, such as NPB, is preferably used as a host material for a green-light-emitting layer, so that light emission can be obtained at the interface between the blue-light-emitting layer and the green-light-emitting layer. That is, in such a case, an aromatic amine compound like NPB is preferable as a host material of a green light-emitting material such as 2PCAPA.

[0189] Yellow to orange light emission can be obtained, for example, by using rubrene, 4-(dicyanomethylene)-2-[p-(dimethylamino)styryl]-6-methyl-4H-pyran (abbreviation: DCM1), 4-(dicyanomethylene)-2-methyl-6-(9-julolidyl)ethenyl-4H-pyran (abbreviation: DCM2), bis[2-(2-thienyl)pyridinato]acetylacetonatoiridium (abbreviation: Ir(thp)₂(acac)), bis(2-phenylquinolino)acetylacetonatoiridium

(abbreviation: Ir(pq)₂(acac)), or the like as a guest material and dispersing the guest material in a suitable host material. In particular, a tetracene derivative such as rubrene is preferable as a guest material because it is highly efficient and chemically stable. As a host material in this case, an aromatic amine compound such as NPB is preferable. Alternatively, a metal complex such as bis(8-quinolinolato)zinc (II) (abbreviation: Znq₂), bis[2-cinnamoyl-8-quinolinolato]zinc (abbreviation: Znsq₂), or the like can be used as a host material. Further alternatively, a polymer, such as poly(2,5-dialkoxy-1,4-phenylenevinylene) may be used.

[0190] Orange to red light emission can be obtained, for example, by using 4-(dicyanomethylene)-2,6-bis[p-(dimethylamino)styryl]-4H-pyran (abbreviation: BisDCM), 4-(dicyanomethylene)-2,6-bis[2-(julolidin-9-yl)ethenyl]-4H-pyran (abbreviation: BisDCJ), 4-(dicyanomethylene)-2-methyl-6-(9-julolidyl)ethenyl-4H-pyran (abbreviation: DCM2), bis[2-(2-thienyl)pyridinato]acetylacetonatoiridium (abbreviation: Ir(thp)₂(acac)), or the like as a guest material and dispersing the guest material in a suitable host material. Orange to red light emission can also be obtained by using a metal complex such as bis(8-quinolinolato)zinc(II) (abbreviation: Znq₂), bis[2-cinnamoyl-8-quinolinolato]zinc (abbreviation: Znsq₂), or the like. Further, a polymer such as poly(3-alkylthiophene) may be used. As a guest material which exhibits red light emission, a 4H-pyran derivative such as 4-(dicyanomethylene)-2,6-bis[p-(dimethylamino)styryl]-4H-pyran (abbreviation: BisDCM), 4-(dicyanomethylene)-2,6-bis[2-(julolidin-9-yl)ethenyl]-4H-pyran (abbreviation: BisDCJ), 4-(dicyanomethylene)-2-methyl-6-(9-julolidyl)ethenyl-4H-pyran (abbreviation: DCM2), {2-isopropyl-6-[2-(2,3,6,7-tetrahydro-1,1,7,7-tetramethyl-1H,5H-benzo[ij]quinolizin-9-yl)ethenyl]-4H-pyran-4-ylidene}propanedinitrile (abbreviation: DCJTI), or {2,6-bis[2-(2,3,6,7-tetrahydro-8-methoxy-1,1,7,7-tetramethyl-1H,5H-benzo[ij]quinolizin-9-yl)ethenyl]-4H-pyran-4-ylidene}propanedinitrile (abbreviation: BisDCJTM) is preferably used because of its high efficiency. In particular, DCJTI and BisDCJTM are preferable, as they have a light emission peak at around 620 nm.

[0191] Note that the light-emitting layer **1013** may have a structure in which the above substance having a light-emitting property (a guest material) is dispersed in another substance (a host material). As the substance with which the substance having a high light-emitting property is dispersed, various kinds of materials can be used, and it is preferable to use a substance whose lowest unoccupied molecular orbital (LUMO) level is higher than that of a substance having a high light-emitting property and whose highest occupied molecular orbital (HOMO) level is lower than that of the substance having a high light-emitting property.

[0192] As the substance with which the substance having a light-emitting property is dispersed, specifically, a metal complex such as tris(8-quinolinolato)aluminum(III) (abbreviation: Alq), tris(4-methyl-8-quinolinolato)aluminum(III) (abbreviation: Almq₃), bis(10-hydroxybenzo[h]quinolino)beryllium(II) (abbreviation: BeBq₂), bis(2-methyl-8-quinolinolato)(4-phenylphenolato)aluminum(III) (abbreviation: BA1q), bis(8-quinolinolato)zinc(II) (abbreviation: Znq₂), bis[2-(2-benzoxazolyl)phenolato]zinc(II) (abbreviation: ZnPBO), or bis[2-(2-benzothiazolyl)phenolato]zinc(II) (abbreviation: ZnBTZ); a heterocyclic compound such as 2-(4-biphenyl)-5-(4-tert-butylphenyl)-1,3,4-oxadiazole (abbreviation: PBD), 1,3-bis[5-(p-tert-butylphenyl)-1,3,4-

oxadiazol-2-yl]benzene (abbreviation: OXD-7), 3-(4-biphenyl)-4-phenyl-5-(4-tert-butylphenyl)-1,2,4-triazole (abbreviation: TAZ), 2,2',2''-(1,3,5-benzenetriyl)tris(1-phenyl-1H-benzimidazole) (abbreviation: TPBI), bathophenanthroline (abbreviation: BPhen), or bathocuproine (abbreviation: BCP); a condensed aromatic compound such as 9-[4-(10-phenyl-9-anthryl)phenyl]-9H-carbazole (abbreviation: CzPA), 3,6-diphenyl-9-[4-(10-phenyl-9-anthryl)phenyl]-9H-carbazole (abbreviation: DPCzPA), 9,10-bis(3,5-diphenylphenyl)anthracene (abbreviation: DPPA), 9,10-di(2-naphthyl)anthracene (abbreviation: DNA), 2-tert-butyl-9,10-di(2-naphthyl)anthracene (abbreviation: t-BuDNA), 9,9'-bianthryl (abbreviation: BANT), 9,9'-(stilbene-3,3'-diyl)diphenanthrene (abbreviation: DPNS), 9,9'-(stilbene-4,4'-diyl)diphenanthrene (abbreviation: DPNS2), 3,3',3''-(benzene-1,3,5-triyl)tripylene (abbreviation: TPB3), 9,10-diphenylanthracene (abbreviation: DPAnth), or 6,12-dimethoxy-5,11-diphenylchrysene; an aromatic amine compound such as N,N-diphenyl-9-[4-(10-phenyl-9-anthryl)phenyl]-9H-carbazol-3-amine (abbreviation: CzAlPA), 4-(10-phenyl-9-anthryl)triphenylamine (abbreviation: DPhPA), N,9-diphenyl-N-[4-(10-phenyl-9-anthryl)phenyl]-9H-carbazol-3-amine (abbreviation: PCAPA), N,9-diphenyl-N-[4-[4-(10-phenyl-9-anthryl)phenyl]phenyl]-9H-carbazol-3-amine (abbreviation: PCAPBA), N-(9,10-diphenyl-2-anthryl)-N,9-diphenyl-9H-carbazol-3-amine (abbreviation: 2PCAPA), NPB (or a-NPD), TPD, DFLDPBi, or BSPB; or the like can be used.

[0193] As a substance with which the substance having a light-emitting property is dispersed, a plurality of kinds of substances can be used. For example, in order to suppress crystallization, a substance such as rubrene which suppresses crystallization, may be further added. In addition, NPB, Alq, or the like may be further added in order to efficiently transfer energy to the substance having a light-emitting property.

[0194] When a structure in which the substance having a light-emitting property is dispersed in another substance is employed, crystallization of the light-emitting layer 1013 can be suppressed. In addition, concentration quenching which results from high concentration of the substance having a light-emitting property can be suppressed.

[0195] The electron-transport layer 1014 is a layer including a substance having a high electron-transport property. As the substance having a high electron-transport property, for example, a layer containing a metal complex having a quinoline skeleton or a benzoquinoline skeleton, such as tris(8-quinolinolato)aluminum(III) (abbreviation: Alq), tris(4-methyl-8-quinolinolato)aluminum(III) (abbreviation: Almq₃), bis(10-hydroxybenzo[h]-quinolinato)beryllium (abbreviation: BeBq₂), or bis(2-methyl-8-quinolinolato)(4-phenylphenolato)aluminum (abbreviation: BAAlq) can be used. In addition, a metal complex or the like including an oxazole-based or thiazole-based ligand, such as bis[2-(2-hydroxyphenyl)benzoxazolato]zinc (abbreviation: Zn(BOX)₂) or bis[2-(2-hydroxyphenyl)benzothiazolato]zinc(II) (abbreviation: Zn(BTZ)₂) can be used. Besides the metal complexes, 2-(4-biphenyl)-5-(4-tert-butylphenyl)-1,3,4-oxadiazole (abbreviation: PBD), 1,3-bis[5-(p-tert-butylphenyl)-1,3,4-oxadiazole-2-yl]benzene (abbreviation: OXD-7), 3-(4-biphenyl)-4-phenyl-5-(4-tert-butylphenyl)-1,2,4-triazole (abbreviation: TAZ), bathophenanthroline (abbreviation: BPhen), bathocuproine (abbreviation: BCP), bis[3-(1H-benzimidazol-2-yl)fluoren-2-olato]zinc(II), bis[3-

(1H-benzimidazol-2-yl)fluoren-2-olato]beryllium(II), bis[2-(1H-benzimidazol-2-yl)dibenzo[b,d]furan-3-olato](phenolato)aluminum(III), bis[2-(benzoxazol-2-yl)-7,8-methylenedioxydibenzo[b,d]furan-3-olato](2-naphtholato)aluminum(III), or the like can also be used. The substances mentioned here are mainly ones that have an electron mobility higher than or equal to 10⁻⁶ cm²/Vs. Note that the electron-transport layer 1014 may be formed of substances other than those described above as long as their electron-transport properties are higher than their hole-transport properties. The electron-transport layer 1014 is not limited to a single layer and may be a stacked layer which includes two or more layers each containing the aforementioned substance.

[0196] The electron-injection layer 1015 is a layer including a substance having a high electron-injection property. As the material having a high electron-injection property, the following can be given: an alkali metal or an alkaline earth metal such as lithium fluoride (LiF), cesium fluoride (CsF), and calcium fluoride (CaF₂), and a compound thereof. It is also possible to use an electron-injection composite material including an organic compound (preferably, an organic compound having an electron-transport property) and an inorganic compound (preferably, an alkali metal, an alkaline earth metal, a rare earth metal, or a compound of these metals). As the electron-injection composite material, for example, a layer made of Alq mixed with magnesium (Mg) may be used. Such a structure increases the efficiency in electron injection from the cathode 1002.

[0197] Note that in the case where the electron-injection layer 1015 is made of the aforementioned electron-injection composite material, a variety of conductive materials such as Al, Ag, ITO, or ITO containing silicon or silicon oxide can be used for the cathode 1002 regardless of the work function.

[0198] Such layers are stacked in appropriate combination, whereby the EL layer 1003 can be formed. The light-emitting layer 1013 may have a stacked-layer structure including two or more layers. The light-emitting layer 1013 has a stacked-layer structure including two or more layers and a different light-emitting substance is used for each light-emitting layer, so that a variety of emission colors can be obtained. In addition, a plurality of light-emitting substances of different colors is used as the light-emitting substance, whereby light emission having a broad spectrum or white light emission can also be obtained. In particular, for a backlight for which high luminance is required, a structure in which light-emitting layers are stacked is preferable.

[0199] Further, as a formation method of the EL layer 1003, a variety of methods (e.g., a dry process and a wet process) can be selected as appropriate depending on a material to be used. For example, a vacuum evaporation method, a sputtering method, an ink-jet method, a spin coating method, or the like can be used. Note that a different formation method may be employed for each layer.

[0200] The EL element 1025 described in this embodiment can be formed by any of a variety of methods regardless of whether it is a dry process (e.g., a vacuum evaporation method or a sputtering method) or a wet process (e.g., an ink-jet method or a spin coating method).

[0201] Note that the structure of the EL element 1025 described in this embodiment may be a structure in which a plurality of EL layers 1003 are stacked between a pair of

electrodes as illustrated in FIG. 11C, that is, a stacked-layer element structure. Note that in the case of a structure in which n (n is a natural number of 2 or more) EL layers 1003 are stacked, an intermediate layer 1004 is provided between an m -th (m is a natural number greater than or equal to 1 and less than or equal to $n-1$) EL layer and an $(m+1)$ -th EL layer. [0202] The intermediate layer 1004 has a function of injecting electrons to one of the EL layers 1003 on the anode 1001 side formed in contact with the intermediate layer 1004, and injecting holes to the other EL layer 1003 on the cathode 1002 side, when a voltage is applied to the anode 1001 and the cathode 1002.

[0203] The intermediate layer 1004 can be made not only by using the aforementioned composite materials (the hole-injection composite material or the electron-injection composite material) of an organic compound and an inorganic compound, but also by appropriately combining materials such as metal oxides. More preferably, the intermediate layer 1004 is made of a combination of the hole-injection composite material and other materials. Such materials used for the intermediate layer 1004 have an excellent carrier-injection property and carrier-transport property, whereby the EL element 1025 driven with low current and low voltage can be realized.

[0204] In a structure of the stacked-layer element, in the case where the EL layer has a two-layer stacked structure, white color light can be extracted outside by allowing a first EL layer and a second EL layer to emit light of complementary colors. White light emission can also be obtained with a structure where the first EL layer and the second EL layer each include a plurality of light-emitting layers emitting light of complementary colors. As a complementary relation, blue and yellow, blue green and red, and the like can be given. A substance which emits light of blue, yellow, blue-green, or red light may be selected as appropriate from, for example, the light-emitting substances given above.

[0205] The following is an example of a structure where each of the first EL layer and the second EL layer includes a plurality of light-emitting layers emitting light of complementary colors. With this structure, white light emission can be obtained.

[0206] For example, the first EL layer includes a first light-emitting layer exhibiting light emission with a spectrum whose peak is in the wavelength range of blue to blue-green, and a second light-emitting layer exhibiting light emission with a spectrum whose peak is in the wavelength range of yellow to orange. The second EL layer includes a third light-emitting layer exhibiting light emission with a spectrum whose peak is in the wavelength range of blue-green to green, and a fourth light-emitting layer exhibiting light emission with a spectrum whose peak is in the wavelength range of orange to red.

[0207] In this case, light emission from the first EL layer is a combination of light emission from both the first light-emitting layer and the second light-emitting layer and thus exhibits a light emission spectrum having peaks both in the wavelength range of blue to blue-green and in the wavelength range of yellow to orange. That is, the first EL layer exhibits light emission having a 2-wavelength-type white color or a 2-wavelength-type color that is similar to white.

[0208] In addition, light emission from the second EL layer is a combination of light emission from both the third light-emitting layer and the fourth light-emitting layer and

thus exhibits a light emission spectrum having peaks both in the wavelength range of blue-green to green and in the wavelength range of orange to red. That is, the second EL layer exhibits light emission having a 2-wavelength-type white color or a 2-wavelength-type color that is similar to white, which is different from the first EL layer.

[0209] Consequently, by combining the light-emission from the first EL layer and the light emission from the second EL layer, white light emission which covers the wavelength range of blue to blue-green, the wavelength range of blue-green to green, the wavelength range of yellow to orange, and the wavelength range of orange to red can be obtained.

[0210] Note that in the structure of the above-mentioned stacked layer element, by provision of intermediate layers between the stacked EL layers, the element can have long lifetime in a high-luminance region while the current density is kept low. In addition, the voltage drop due to resistance of the electrode material can be reduced, whereby uniform light emission in a large area is possible.

[0211] Note that the backlight portion described in FIGS. 10A to 10C and FIGS. 11A to 11C may have a structure in which luminance is adjusted. For example, a structure in which luminance is adjusted in accordance with illuminance around the liquid crystal display device or a structure in which luminance is adjusted in accordance with a displayed image signal may be employed.

[0212] Note that color display is enabled by combination of color filters. Alternatively, other optical films (such as a polarizing film, a retardation film, and an anti-reflection film) can also be used in combination. Note that the color filter is not always provided in the case where light-emitting diodes of RGB or the like are arranged in a backlight and a successive additive color mixing method (a field sequential method) in which color display is performed by time division is employed.

[0213] Note that this embodiment can be freely combined with the other embodiments.

Embodiment 4

[0214] In this embodiment, an example of a transistor that can be applied to a liquid crystal display device disclosed in this specification will be described. There is no particular limitation on a structure of the transistor that can be applied to the liquid crystal display device disclosed in this specification. For example, a staggered transistor, a planar transistor, or the like having a top-gate structure in which a gate electrode is placed on an upper side of an oxide semiconductor layer with a gate insulating layer interposed or a bottom-gate structure in which a gate electrode is placed on a lower side of an oxide semiconductor layer with a gate insulating layer interposed, can be used. The transistor may have a single gate structure including one channel formation region, a double gate structure including two channel formation regions, or a triple gate structure including three channel formation regions. Alternatively, the transistor may have a dual gate structure including two gate electrode layers placed over and below a channel region with a gate insulating layer interposed. FIGS. 12A to 12D illustrate examples of cross-sectional structures of transistors. Each of the transistors illustrated in FIGS. 12A to 12D uses an oxide semiconductor as a semiconductor. An advantage of using an oxide semiconductor is that field-effect mobility (the maximum value is greater than or equal to $5 \text{ cm}^2/\text{Vsec}$,

preferably in the range of $10 \text{ cm}^2/\text{Vsec}$ to $150 \text{ cm}^2/\text{Vsec}$ can be obtained when a transistor is on, and low off current (less than $1 \text{ nA}/\mu\text{m}$, preferably less than $10 \text{ zA}/\mu\text{m}$ at room temperature and less than $100 \text{ zA}/\mu\text{m}$ at 85° C.) can be obtained when the transistor is off.

[0215] A transistor 410 illustrated in FIG. 12A is one of bottom-gate transistors and is also referred to as an inverted staggered transistor.

[0216] The transistor 410 includes, over a substrate 400 having an insulating surface, a gate electrode layer 401, a gate insulating layer 402, an oxide semiconductor layer 403, a source electrode layer 405a, and a drain electrode layer 405b. An insulating film 407 is provided to cover the transistor 410 and be stacked over the oxide semiconductor layer 403. Further, a protective insulating layer 409 is formed over the insulating film 407.

[0217] A transistor 420 illustrated in FIG. 12B is one of bottom-gate transistors referred to as a channel-protective type (also referred to as a channel-stop type) and is also referred to as an inverted staggered transistor.

[0218] The transistor 420 includes, over the substrate 400 having an insulating surface, the gate electrode layer 401, the gate insulating layer 402, the oxide semiconductor layer 403, an insulating layer 427 functioning as a channel protective layer covering a channel formation region of the oxide semiconductor layer 403, the source electrode layer 405a, and the drain electrode layer 405b. Further, the protective insulating layer 409 is formed to cover the transistor 420.

[0219] A transistor 430 illustrated in FIG. 12C is a bottom-gate transistor and includes, over the substrate 400 having an insulating surface, the gate electrode layer 401, the gate insulating layer 402, the source electrode layer 405a, the drain electrode layer 405b, and the oxide semiconductor layer 403. The insulating film 407 is provided to cover the transistor 430 and to be in contact with the oxide semiconductor layer 403. Further, the protective insulating layer 409 is formed over the insulating film 407.

[0220] In the transistor 430, the gate insulating layer 402 is provided over and in contact with the substrate 400 and the gate electrode layer 401; the source electrode layer 405a and the drain electrode layer 405b are provided over and in contact with the gate insulating layer 402. The oxide semiconductor layer 403 is provided over the gate insulating layer 402, the source electrode layer 405a, and the drain electrode layer 405b.

[0221] A transistor 440 illustrated in FIG. 12D is one of top-gate transistors. The transistor 440 includes, over the substrate 400 having an insulating surface, an insulating layer 437, the oxide semiconductor layer 403, the source electrode layer 405a, the drain electrode layer 405b, the gate insulating layer 402, and the gate electrode layer 401. A wiring layer 436a and a wiring layer 436b are provided in contact with and electrically connected to the source electrode layer 405a and the drain electrode layer 405b respectively.

[0222] In this embodiment, the oxide semiconductor layer 403 is used as a semiconductor layer as described above. As an oxide semiconductor used for the oxide semiconductor layer 403, the following metal oxides can be used: a four-component metal oxide such as an In—Sn—Ga—Zn—O-based oxide semiconductor; a three-component metal oxide such as an In—Ga—Zn—O-based oxide semiconductor, an In—Sn—Zn—O-based oxide semiconductor, an In—Al—

Zn—O-based oxide semiconductor, a Sn—Ga—Zn—O-based oxide semiconductor, an Al—Ga—Zn—O-based oxide semiconductor, and a Sn—Al—Zn—O-based oxide semiconductor; a two-component metal oxide such as an In—Zn—O-based oxide semiconductor, a Sn—Zn—O-based oxide semiconductor, an Al—Zn—O-based oxide semiconductor, a Zn—Mg—O-based oxide semiconductor, a Sn—Mg—O-based oxide semiconductor, an In—Mg—O-based oxide semiconductor; an In—O-based oxide semiconductor; a Sn—O-based oxide semiconductor; and a Zn—O-based oxide semiconductor. In addition, SiO_2 may be contained in the above oxide semiconductor. Here, for example, an In—Ga—Zn—O-based oxide semiconductor means an oxide film containing indium (In), gallium (Ga), and zinc (Zn), and there is no particular limitation on the stoichiometric proportion thereof. The In—Ga—Zn—O-based oxide semiconductor may contain an element other than In, Ga, and Zn.

[0223] As the oxide semiconductor layer 403, a thin film expressed by a chemical formula of $\text{InMO}_3(\text{ZnO})_m$ ($m > 0$, where m is not an integer) can be used. Here, M represents one or more metal elements selected from Ga, Al, Mn, and Co. For example, M can be Ga, Ga and Al, Ga and Mn, Ga and Co, or the like.

[0224] In each of the transistors 410, 420, 430, and 440 using the oxide semiconductor layer 403, the current value in an off state (off current value) can be reduced. Thus, the holding period of an electric signal of an image signal or the like can be extended and an interval between writing operations can be set longer in the state where power supply is on. Consequently, the frequency of refresh operation can be decreased, whereby power consumption can be effectively suppressed.

[0225] In addition, each of the transistors 410, 420, 430, and 440 using the oxide semiconductor layer 403 can operate at high speed because relatively high field-effect mobility can be obtained. Consequently, when the above transistors are used in a pixel portion of a liquid crystal display device, color separation can be suppressed and high-quality images can be obtained. In addition, since the transistors can be separately formed in a driver circuit portion and a pixel portion over one substrate, the number of components of the liquid crystal display device can be reduced.

[0226] There is no limitation on a substrate that can be applied to the substrate 400 having an insulating surface; however, a glass substrate such as a glass substrate made of barium borosilicate glass or aluminosilicate glass is used.

[0227] In the bottom-gate transistors 410, 420, and 430, an insulating film serving as a base film may be provided between the substrate and the gate electrode layer. The base film has a function of preventing diffusion of an impurity element from the substrate, and can be formed to have a stacked-layer structure using one or more of a silicon nitride film, a silicon oxide film, a silicon nitride oxide film, and a silicon oxynitride film.

[0228] The gate electrode layer 401 can be formed to have a single-layer structure or a stacked-layer structure using a metal material such as molybdenum, titanium, chromium, tantalum, tungsten, aluminum, copper, neodymium, or scandium, or an alloy material which contains any of these materials as its main component.

[0229] The gate insulating layer 402 can be formed with a single-layer structure or a layered structure using any of a

silicon oxide layer, a silicon nitride layer, a silicon oxynitride layer, a silicon nitride oxide layer, an aluminum oxide layer, an aluminum nitride layer, an aluminum oxynitride layer, an aluminum nitride oxide layer, and a hafnium oxide layer by a plasma CVD method, a sputtering method, or the like. For example, a silicon nitride layer (SiN_y , ($y>0$)) having a thickness of 50 nm to 200 nm inclusive is formed as a first gate insulating layer with a plasma CVD method, and a silicon oxide layer (SiO_x , ($x>0$)) having a thickness of 5 nm to 300 nm inclusive is formed as a second gate insulating layer over the first gate insulating layer, so that a gate insulating layer with a total thickness of 200 nm is formed.

[0230] As a conductive film used for the source electrode layer **405a** and the drain electrode layer **405b**, for example, a metal film containing an element selected from Al, Cr, Cu, Ta, Ti, Mo, and W and a metal nitride film containing any of the above elements as its main component (a titanium nitride film, a molybdenum nitride film, and a tungsten nitride film) can be used. A metal film having a high melting point of Ti, Mo, W, or the like or a metal nitride film of any of these elements (a titanium nitride film, a molybdenum nitride film, and a tungsten nitride film) may be stacked on one of or both of a lower side or an upper side of a metal film of Al, Cu, or the like.

[0231] A material similar to that of the source electrode layer **405a** and the drain electrode layer **405b** can be also used for a conductive film used for the wiring layer **436a** and the wiring layer **436b** which are connected to the source electrode layer **405a** and the drain electrode layer **405b** respectively.

[0232] The conductive film to be the source electrode layer **405a** and the drain electrode layer **405b** (including a wiring layer formed using the same layer as the source electrode layer **405a** and the drain electrode layer **405b**) may be formed using a conductive metal oxide. As the conductive metal oxide, indium oxide (In_2O_3), tin oxide (SnO_2), zinc oxide (ZnO), an alloy of indium oxide and tin oxide ($\text{In}_2\text{O}_3\text{—SnO}_2$, referred to as ITO), an alloy of indium oxide and zinc oxide ($\text{In}_2\text{O}_3\text{—ZnO}$), and such a metal oxide material containing silicon oxide can be used.

[0233] As the insulating films **407**, **427**, and **437**, an inorganic insulating film such as a silicon oxide film, a silicon oxynitride film, an aluminum oxide film, or an aluminum oxynitride film can be typically used.

[0234] For the protective insulating layer **409** provided over the oxide semiconductor layer, an inorganic insulating film such as a silicon nitride film, an aluminum nitride film, a silicon nitride oxide film, or an aluminum nitride oxide film can be used.

[0235] Further, a planarization insulating film may be formed over the protective insulating layer **409** so that surface roughness due to the transistor is reduced. As the planarization insulating film, an organic material such as polyimide, acrylic, and benzocyclobutene can be used. Besides the above organic materials, a low-dielectric constant material (a low-k material) or the like can be used. Note that the planarization insulating film may be formed by stacking a plurality of insulating films formed of any of these materials.

[0236] An example of a pixel in a liquid crystal display device using such a transistor is illustrated in FIG. **20** and FIG. **21**. A structure of the pixel of the liquid crystal display device illustrated in FIG. **20** and FIG. **21** is an example of a vertical alignment (VA) liquid crystal pixel. The VA mode

is a mode of controlling alignment of liquid crystal molecules of a liquid crystal panel. The VA mode is a mode in which liquid crystal molecules are aligned vertically to a panel surface when no voltage is applied.

[0237] FIG. **20** illustrates a plan view of the pixel and FIG. **21** illustrates a cross-sectional view taken along a line A-B shown in FIG. **20**. Note that FIG. **20** illustrates a plan view of the substrate **400** over which a transistor **410** is formed, and FIG. **21** illustrates a structure in which a counter substrate **416** and a liquid crystal layer **414** are formed in addition to a structure of the substrate **400** over which a transistor **410** is formed. The following description will be given with reference to both FIG. **20** and FIG. **21**.

[0238] The transistors **410a** and **410b** have the same structure as that in FIG. **12A** and each include the gate electrode layer **401**, the gate insulating layer **402**, and the oxide semiconductor layer **403**. The gate electrode layer **401** is shared by the transistors **410a** and **410b**. When a pixel is provided, the gate electrode layer **401** is formed to extend in one direction. The oxide semiconductor layer **403** is provided to overlap with the gate electrode layer **401** with the gate insulating layer **402** interposed therebetween. The source electrode layer **405a** and the drain electrode layer **405b** are provided on an upper side of the oxide semiconductor layer **403** (note that here, the terms “the source electrode layer **405a**” and “the drain electrode layer **405b**” are used for convenience to distinguish electrodes in the transistor **410** (between source and drain)). The source electrode layer **405a** is extended in direction to get across the gate electrode layer **401**. A planarization film **421** is formed over the protective insulating layer **409** and a pixel electrode **411a** and a pixel electrode **411b** are formed thereover. The pixel electrode **411a** is connected to the transistor **410a** and the pixel electrode **411b** is connected to the transistor **410b**. The pixel electrode **411a** is connected to the drain electrode layer **405b** through a contact hole **412**. The pixel electrode **411b** is connected thereto in a similar manner. The pixel electrodes **411a** and **411b** are formed from a transparent electrode material such as indium tin oxide, zinc oxide, or tin oxide.

[0239] A storage capacitor **419** may be provided as appropriate. When the storage capacitor **419** is provided, the storage capacitor **419** is formed using capacitor wiring layers **417a** and **417b** and capacitor electrode layers **418a** and **418b** which are formed from the same layer as the gate electrode layer **401**. Between the capacitor wiring layers **417a** and **417b** and the capacitor electrode layers **418a** and **418b**, the gate insulating layer **402** is extended to function as a dielectric, so that the storage capacitors **419a** and **419b** are formed.

[0240] In FIG. **20**, two subunits each of which includes a transistor and a pixel electrode are combined to form one unit. That is, the pixel electrode **411a** and the pixel electrode **411b** each form a subunit. In this case, the potential of the capacitor electrode layer **417a** is made different from that of a capacitor electrode layer **417b**, so that the potential of the pixel electrode **411a** can be made different from that of the pixel electrode **411b**. In other words, the potentials of the capacitor electrode layers **417a** and **417b** are individually controlled, so that alignment of liquid crystal is precisely controlled and a viewing angle can be increased.

[0241] FIG. **21** illustrates a mode in which the substrate **400** and the counter substrate **416** are overlapped with each other with the liquid crystal layer **414** therebetween. In the

position of the counter substrate **416** where the spacer **422** is formed, a light-shielding layer **423**, a first coloring layer **424**, a second coloring layer **425**, a third coloring layer **426**, and the counter electrode **415** are formed. With this structure, the height of a projected rib **428** to control alignment of liquid crystal is made different from that of the spacer **422**. Each of the pixel electrode **411** and the counter electrode **415** is provided with an alignment film **413**. Alignment treatment for the alignment film **413** may be performed by an optical alignment method or a rubbing method.

[0242] Note that other than the VA mode, a twisted nematic (TN) mode, a multi-domain vertical alignment (MVA) mode, an in-plane switching (IPS) mode, a continuous pinwheel alignment (CPA) mode, a patterned vertical alignment (PVA) mode, or the like can be applied. As a liquid crystal phase of the liquid crystal layer **414**, a nematic phase, a smectic phase, a cholesteric phase, a blue phase, or the like can be used.

[0243] In such a manner, by using a transistor including an oxide semiconductor layer having high field-effect mobility and low off current in this embodiment, a liquid crystal display device with low power consumption can be provided.

Embodiment 5

[0244] In this embodiment, examples of a transistor including an oxide semiconductor layer and a manufacturing method thereof will be described in detail below with reference to FIGS. **13A** to **13E**. The same portion as or a portion having a function similar to those in the above embodiments can be formed in a manner similar to that described in the above embodiments, and also the steps similar to those in the above embodiments can be performed in a manner similar to that described in the above embodiments, and repetitive description is omitted. In addition, detailed description of the same portions is not repeated.

[0245] FIGS. **13A** to **13E** illustrate an example of a cross-sectional structure of a transistor. A transistor **510** illustrated in FIGS. **13A** to **13E** is an inverted staggered thin film transistor having a bottom gate structure, which is similar to the transistor **410** illustrated in FIG. **12A**.

[0246] Hereinafter, a manufacturing process of the transistor **510** over a substrate **505** is described with reference to FIGS. **13A** to **13E**.

[0247] First, a conductive film is formed over the substrate **505** having an insulating surface, and then, a gate electrode layer **511** is formed through a first photolithography step. Note that a resist mask may be formed by an inkjet method. Formation of the resist mask by an inkjet method needs no photomask; thus, manufacturing cost can be reduced.

[0248] As the substrate **505** having an insulating surface, a substrate similar to the substrate **400** described in Embodiment 4 can be used. In this embodiment, a glass substrate is used as the substrate **505**.

[0249] An insulating film serving as a base film may be provided between the substrate **505** and the gate electrode layer **511**. The base film has a function of preventing diffusion of an impurity element from the substrate **505**, and can be formed with a single-layer structure or a stacked-layer structure using one or more of a silicon nitride film, a silicon oxide film, a silicon nitride oxide film, and a silicon oxynitride film.

[0250] The gate electrode layer **511** can be formed to have a single-layer structure or a stacked-layer structure using any

of a metal material such as molybdenum, titanium, tantalum, tungsten, aluminum, copper, neodymium, or scandium, and an alloy material which includes any of these as a main component.

[0251] Next, a gate insulating layer **507** is formed over the gate electrode layer **511**. The gate insulating layer **507** can be formed by a plasma CVD method, a sputtering method, or the like to have a single layer structure or a stacked-layer structure using any of a silicon oxide layer, a silicon nitride layer, a silicon oxynitride layer, a silicon nitride oxide layer, an aluminum oxide layer, an aluminum nitride layer, an aluminum oxynitride layer, an aluminum nitride oxide layer, and a hafnium oxide layer.

[0252] For the oxide semiconductor in this embodiment, an oxide semiconductor which is made to be an i-type semiconductor or a substantially i-type semiconductor by removing an impurity is used. Such a highly purified oxide semiconductor is highly sensitive to an interface state and interface charges; thus, an interface between the oxide semiconductor layer and the gate insulating layer is important. For that reason, the gate insulating layer that is to be in contact with a highly purified oxide semiconductor needs to have high quality.

[0253] For example, high-density plasma CVD using microwaves (e.g., with a frequency of 2.45 GHz) is preferably adopted because an insulating layer can be dense and have high withstand voltage and high quality. The highly purified oxide semiconductor and the high-quality gate insulating layer are in close contact with each other, whereby the interface state density can be reduced to obtain favorable interface characteristics.

[0254] Needless to say, another formation method such as a sputtering method or a plasma CVD method can be employed as long as the method enables formation of a high-quality insulating layer as a gate insulating layer. Further, an insulating layer whose film quality and characteristics of the interface between the insulating layer and an oxide semiconductor are improved by heat treatment which is performed after formation of the insulating layer may be formed as a gate insulating layer. In any case, any insulating layer may be used as long as the insulating layer has characteristics of enabling a reduction in interface state density of the interface between the insulating layer and an oxide semiconductor and formation of a favorable interface as well as having favorable film quality as a gate insulating layer.

[0255] In order to contain hydrogen, a hydroxyl group, and moisture in the gate insulating layer **507** and an oxide semiconductor film **530** as little as possible, it is preferable to perform pretreatment for formation of the oxide semiconductor film **530**. As the pretreatment, the substrate **505** provided with the gate electrode layer **511** or a substrate **505** over which the gate electrode layer **511** and the gate insulating layer **507** are formed is preheated in a preheating chamber of a sputtering apparatus, whereby an impurity such as hydrogen or moisture adsorbed on the substrate **505** is removed and then, evacuation is performed. As an evacuation unit provided in the preheating chamber, a cryopump is preferable. Note that this preheating treatment can be omitted. Further, the above preheating may be performed in a similar manner, on the substrate **505** in a state where a source electrode layer **515a** and a drain electrode layer **515b** have been formed thereover but an insulating layer **516** has not been formed yet.

[0256] Next, over the gate insulating layer 507, the oxide semiconductor film 530 having a thickness greater than or equal to 2 nm and less than or equal to 200 nm, preferably greater than or equal to 5 nm and less than or equal to 30 nm is formed (see FIG. 13A).

[0257] Note that before the oxide semiconductor film 530 is formed by a sputtering method, powder substances (also referred to as particles or dust) which attach on a surface of the gate insulating layer 507 are preferably removed by reverse sputtering in which an argon gas is introduced and plasma is generated. The reverse sputtering refers to a method in which, without applying a voltage to a target side, an RF power source is used for application of a voltage to a substrate side in an argon atmosphere to generate plasma in the vicinity of the substrate to modify a surface. Note that instead of an argon atmosphere, a nitrogen atmosphere, a helium atmosphere, an oxygen atmosphere, or the like may be used.

[0258] As an oxide semiconductor for the oxide semiconductor film 530, the oxide semiconductor described in Embodiment 4 can be used. Further, SiO₂ may be contained in the above oxide semiconductor. In this embodiment, the oxide semiconductor film 530 is deposited by a sputtering method with the use of an In—Ga—Zn—O-based oxide target. A cross-sectional view at this stage is illustrated in FIG. 13A. Alternatively, the oxide semiconductor film 530 can be formed by a sputtering method in a rare gas (typically argon) atmosphere, an oxygen atmosphere, or a mixed atmosphere containing a rare gas (typically argon) and oxygen.

[0259] The target used for formation of the oxide semiconductor film 530 by a sputtering method is, for example, a metal oxide target containing In₂O₃, Ga₂O₃, and ZnO at a composition ratio of 1:1:1 [molar ratio], so that an In—Ga—Zn—O film is formed. Without limitation to the material and the component of the target, for example, a metal oxide target containing In₂O₃, Ga₂O₃, and ZnO at 1:1:2 [molar ratio] may be used.

[0260] The filling factor of the metal oxide target is greater than or equal to 90% and less than or equal to 100%, preferably greater than or equal to 95% and less than or equal to 99.9%. With use of the metal oxide target with high filling factor, a dense oxide semiconductor film can be formed.

[0261] It is preferable that a high-purity gas from which an impurity such as hydrogen, water, a hydroxyl group, or a hydride has been removed be used as a sputtering gas used for forming the oxide semiconductor film 530.

[0262] The substrate is held in a deposition chamber kept under reduced pressure, and the substrate temperature is set to 100° C. to 600° C. inclusive, preferably 200° C. to 400° C. inclusive. Formation of the oxide semiconductor film is conducted with heating the substrate, whereby the concentration of impurities included in the formed oxide semiconductor film can be reduced. In addition, damage by sputtering can be reduced. Then, a sputtering gas from which hydrogen and moisture are removed is introduced into the deposition chamber where remaining moisture is being removed, and the oxide semiconductor film 530 is deposited with use of the above target, over the substrate 505. In order to remove remaining moisture from the deposition chamber, an adsorption-type vacuum pump such as a cryopump, an ion pump, or a titanium sublimation pump is preferably used. The evacuation unit may be a turbo pump provided

with a cold trap. In the deposition chamber which is evacuated with use of the cryopump, a hydrogen atom, a compound including a hydrogen atom, such as water (H₂O), (more preferably, also a compound including a carbon atom), and the like are removed, whereby the concentration of impurities in the oxide semiconductor film formed in the deposition chamber can be reduced.

[0263] As one example of the deposition condition, the distance between the substrate and the target is 100 mm, the pressure is 0.6 Pa, the direct-current (DC) power source is 0.5 kW, and the atmosphere is an oxygen atmosphere (the proportion of the oxygen flow rate is 100%). Note that use of a pulse direct current power source is preferable because powder substances (also referred to as particles or dust) generated in film formation can be reduced and the film thickness can be uniform.

[0264] Then, through a second photolithography step, the oxide semiconductor film 530 is processed into an island-shaped oxide semiconductor layer. A resist mask for forming the island-shaped oxide semiconductor layer may be formed by an ink jet method. Formation of the resist mask by an inkjet method needs no photomask; thus, manufacturing cost can be reduced.

[0265] In the case where a contact hole is formed in the gate insulating layer 507, a step of forming the contact hole can be performed at the same time as processing of the oxide semiconductor film 530.

[0266] Note that the etching of the oxide semiconductor film 530 may be dry etching, wet etching, or both dry etching and wet etching. As an etchant used for wet etching of the oxide semiconductor film 530, for example, a mixed solution of phosphoric acid, acetic acid, and nitric acid, such as ITO07N (produced by KANTO CHEMICAL CO., INC.) can be used.

[0267] Next, the oxide semiconductor layer is subjected to first heat treatment. By this first heat treatment, the oxide semiconductor layer can be dehydrated or dehydrogenated. The temperature of the first heat treatment is higher than or equal to 400° C. and lower than or equal to 750° C., preferably higher than or equal to 400° C. and lower than the strain point of the substrate. Here, the substrate is introduced into an electric furnace which is one of heat treatment apparatuses, heat treatment is performed on the oxide semiconductor layer in a nitrogen atmosphere at 450° C. for one hour, and then, the oxide semiconductor layer is not exposed to the air so that entry of water and hydrogen into the oxide semiconductor layer is prevented; thus, an oxide semiconductor layer 531 is obtained (see FIG. 13B).

[0268] Further, a heat treatment apparatus used in this step is not limited to an electric furnace, and a device for heating an object to be processed by heat conduction or heat radiation from a heating element such as a resistance heating element may be alternatively used. For example, an RTA (rapid thermal anneal) apparatus such as a GRTA (gas rapid thermal anneal) apparatus or an LRTA (lamp rapid thermal anneal) apparatus can be used. An LRTA apparatus is an apparatus for heating an object to be processed by radiation of light (an electromagnetic wave) emitted from a lamp such as a halogen lamp, a metal halide lamp, a xenon arc lamp, a carbon arc lamp, a high pressure sodium lamp, or a high pressure mercury lamp. A GRTA apparatus is an apparatus for heat treatment using a high-temperature gas. As the high temperature gas, an inert gas which does not react with an

object to be processed by heat treatment, such as nitrogen or a rare gas like argon, is used.

[0269] For example, as the first heat treatment, GRTA may be performed as follows: the substrate is transferred and put into an inert gas heated to a high temperature as high as 650° C. to 700° C., heated for several minutes, and taken out from the inert gas heated to the high temperature.

[0270] Note that in the first heat treatment, it is preferable that water, hydrogen, and the like be not contained in the atmosphere of nitrogen or a rare gas such as helium, neon, or argon. The purity of nitrogen or the rare gas such as helium, neon, or argon which is introduced into the heat treatment apparatus is preferably set to be 6N (99.9999%) or higher, far preferably 7N (99.99999%) or higher (that is, the impurity concentration is preferably 1 ppm or lower, far preferably 0.1 ppm or lower).

[0271] After the oxide semiconductor layer is heated by the first heat treatment, a high-purity oxygen gas, a high-purity N₂O gas, or ultra-dry air (having a dew point of -40° C. or lower, preferably -60° C. or lower) may be introduced into the same furnace. It is preferable that water, hydrogen, or the like be not contained in the oxygen gas or the N₂O gas. Alternatively, the purity of an oxygen gas or an N₂O gas which is introduced into the heat treatment apparatus is preferably 6N or more, further preferably 7N or more (i.e., the impurity concentration of the oxygen gas or the N₂O gas is 1 ppm or lower, preferably 0.1 ppm or lower). Although oxygen which is a main component included in the oxide semiconductor has been reduced through the elimination of impurities by performance of dehydration treatment or dehydrogenation treatment, oxygen is supplied by the effect of introduction of the oxygen gas or the N₂O gas in the above manner, so that the oxide semiconductor layer is highly purified and made to be an electrically i-type (intrinsic) semiconductor.

[0272] Alternatively, the first heat treatment of the oxide semiconductor layer can be performed on the oxide semiconductor film 530 which has not yet been processed into the island-shaped oxide semiconductor layer. In that case, the substrate is taken out from the heat apparatus after the first heat treatment, and then a photolithography step is performed.

[0273] Note that other than the above timing, the first heat treatment may be performed at any of the following timings as long as it is after the oxide semiconductor layer is formed. For example, the timing may be after a source electrode layer and a drain electrode layer are formed over the oxide semiconductor layer or after an insulating layer is formed over the source electrode layer and the drain electrode layer.

[0274] Further, in the case where a contact hole is formed in the gate insulating layer 507, the formation of the contact hole may be performed before or after the first heat treatment is performed on the oxide semiconductor film 530.

[0275] Alternatively, an oxide semiconductor layer may be formed through two deposition steps and two heat treatment steps. The thus formed oxide semiconductor layer has a thick crystalline region (non-single-crystal region), that is, a crystalline region the c-axis of which is aligned in a direction perpendicular to a surface of the layer, even when a base component includes any of an oxide, a nitride, a metal, or the like. For example, a first oxide semiconductor film with a thickness greater than or equal to 3 nm and less than or equal to 15 nm is deposited, and first heat treatment is performed in a nitrogen, oxygen, rare gas, or dry air

atmosphere at 450° C. to 850° C. inclusive, preferably 550° C. to 750° C. inclusive, so that the first oxide semiconductor film has a crystalline region (including a plate-like crystal) in a region including its surface. Then, a second oxide semiconductor film which has a larger thickness than the first oxide semiconductor film is formed, and second heat treatment is performed at 450° C. to 850° C. inclusive or preferably 600° C. to 700° C. inclusive, so that crystal growth proceeds upward with use of the first oxide semiconductor film as a seed of the crystal growth and the whole second oxide semiconductor film is crystallized. In such a manner, the oxide semiconductor layer having a thick crystalline region may be obtained.

[0276] Next, a conductive film to be the source and drain electrode layers (including a wiring formed in the same layer as the source and drain electrode layers) is formed over the gate insulating layer 507 and the oxide semiconductor layer 531. The conductive film to be the source and drain electrode layers can be formed using the material which is used for the source electrode layer 405a and the drain electrode layer 405b described in Embodiment 4.

[0277] By performance of a third photolithography step, a resist mask is formed over the conductive film, and selective etching is performed, so that the source electrode layer 515a and the drain electrode layer 515b are formed. Then, the resist mask is removed (see FIG. 13C).

[0278] Light exposure at the time of the formation of the resist mask in the third photolithography step may be performed using ultraviolet light, KrF laser light, or ArF laser light. A channel length L of the transistor formed later is determined by the distance between the lower edge portion of the source electrode layer and the lower edge portion of the drain electrode layer which are next to each other over the oxide semiconductor layer 531. In the case where a channel length L is less than 25 nm, light exposure for formation of the resist mask in the third photolithography step may be performed using extreme ultraviolet light having an extremely short wavelength of several nanometers to several tens of nanometers. In the light exposure by extreme ultraviolet light, the resolution is high and the focus depth is large. For these reasons, the channel length L of the transistor to be formed later can be in the range of 10 nm to 1000 nm inclusive, and the circuit can operate at high speed.

[0279] In order to reduce the number of photomasks used in a photolithography step and reduce the number of steps, an etching step may be performed with the use of a multi-tone mask which is a light-exposure mask through which light is transmitted to have a plurality of intensities. A resist mask formed with use of a multi-tone mask has a plurality of thicknesses and further can be changed in shape by etching; therefore, the resist mask can be used in a plurality of etching steps for processing into different patterns. Therefore, a resist mask corresponding to at least two or more kinds of different patterns can be formed with one multi-tone mask. Thus, the number of light-exposure masks can be reduced and the number of corresponding photolithography steps can be also reduced, whereby simplification of a process can be realized.

[0280] Note that when the conductive film is etched, the optimum etching condition is desirably made so that the oxide semiconductor layer 531 can be prevented to be etched together with the conductive film and divided. However, it is difficult to attain such a condition that only the conductive film is etched and the oxide semiconductor layer

531 is not etched at all. In etching of the conductive film, the oxide semiconductor layer **531** is partly etched in some cases, whereby the oxide semiconductor layer having a groove portion (a depressed portion) is formed.

[0281] In this embodiment, since a titanium (Ti) film is used as the conductive film and the In—Ga—Zn—O-based oxide semiconductor is used for the oxide semiconductor layer **531**, an ammonium hydrogen peroxide mixture (31 wt. % hydrogen peroxide water: 28 wt. % ammonia water: water=5:2:2) is used as an etchant of the Ti film.

[0282] Next, by plasma treatment using a gas such as N₂O, N₂, or Ar, water or the like adsorbed to a surface of an exposed portion of the oxide semiconductor layer may be removed. In the case where the plasma treatment is performed, the insulating layer **516** which serves as a protective insulating film in contact with part of the oxide semiconductor layer is formed without exposure to the air.

[0283] The insulating layer **516** can be formed to a thickness of at least 1 nm by a method by which an impurity such as water or hydrogen does not enter the insulating layer **516**, such as a sputtering method as appropriate. When hydrogen is contained in the insulating layer **516**, the hydrogen enters the oxide semiconductor layer or extracts oxygen from the oxide semiconductor layer, which causes a reduction in resistance of a back channel of the oxide semiconductor layer (i.e., makes an n-type back channel), so that a parasitic channel might be formed. Therefore, it is important for the insulating layer **516** that hydrogen is not used in a formation method in order to contain hydrogen as little as possible.

[0284] In this embodiment, a silicon oxide film is formed to a thickness of 200 nm as the insulating layer **516** by a sputtering method. The substrate temperature in film formation may be higher than or equal to room temperature and lower than or equal to 300° C. and in this embodiment, is 100° C. The silicon oxide film can be formed by a sputtering method in a rare gas (typically argon) atmosphere, an oxygen atmosphere, or a mixed atmosphere containing a rare gas and oxygen. As a target, a silicon oxide target or a silicon target may be used. For example, the silicon oxide film can be formed using a silicon target by a sputtering method in an atmosphere containing oxygen. As the insulating layer **516** which is formed in contact with the oxide semiconductor layer, an inorganic insulating film which does not include an impurity such as moisture, a hydrogen ion, or OH⁻ and blocks the entry of the impurity from the outside is used. Typically, a silicon oxide film, a silicon oxynitride film, an aluminum oxide film, an aluminum oxynitride film, or the like is used.

[0285] As in the case of formation of the oxide semiconductor film **530**, an adsorption-type vacuum pump (such as a cryopump) is preferably used in order to remove remaining moisture in a deposition chamber of the insulating layer **516**. When the insulating layer **516** is deposited in the deposition chamber which is evacuated with use of a cryopump, the concentration of an impurity contained in the insulating layer **516** can be reduced. Alternatively, the evacuation unit used for removal of the remaining moisture in the deposition chamber may be a turbo pump provided with a cold trap.

[0286] It is preferable that a high-purity gas from which impurities such as hydrogen, water, a hydroxyl group, or a hydride have been removed be used as a sputtering gas used for forming the insulating layer **516**.

[0287] Next, second heat treatment is performed in an inert gas atmosphere or an oxygen gas atmosphere (prefer-

ably at from 200° C. to 400° C., e.g. 250° C. to 350° C. inclusive). For example, the second heat treatment is performed in a nitrogen atmosphere at 250° C. for one hour. The second heat treatment is performed in such a condition that part (a channel formation region) of the oxide semiconductor layer is in contact with the insulating layer **516**.

[0288] As described above, an impurity such as hydrogen, moisture, a hydroxyl group, or a hydride (also referred to as a hydrogen compound) is intentionally removed from the oxide semiconductor layer by subjecting the oxide semiconductor layer to the first heat treatment, and then oxygen which is one of main components of the oxide semiconductor can be supplied because oxygen has been reduced in the step of removing impurities. Through the above steps, the oxide semiconductor layer is highly purified and is made to be an electrically i-type (intrinsic) semiconductor.

[0289] Through the above process, the transistor **510** is formed (see FIG. 13D).

[0290] When a silicon oxide layer having a lot of defects is used as the insulating layer **516**, an impurity such as hydrogen, moisture, a hydroxyl group, or a hydride contained in the oxide semiconductor layer can be diffused by the heat treatment which is performed after the formation of the silicon oxide layer, so that impurities in the oxide semiconductor layer can be further reduced.

[0291] A protective insulating layer **506** may be formed over the insulating layer **516**. For example, a silicon nitride film is formed by an RF sputtering method. Since an RF sputtering method has high productivity, it is a preferable method used for formation of the protective insulating layer. As the protective insulating layer, an inorganic insulating film which does not include an impurity such as moisture and blocks entry of the impurity from the outside, e.g., a silicon nitride film, an aluminum nitride film, or the like is used. In this embodiment, the protective insulating layer **506** is formed using a silicon nitride film (see FIG. 13E).

[0292] In this embodiment, as the protective insulating layer **506**, a silicon nitride film is formed by heating the substrate **505** over which the steps up to and including the formation step of the insulating layer **516** have been done, to a temperature of 100° C. to 400° C., introducing a sputtering gas including high-purity nitrogen from which hydrogen and moisture are removed, and using a silicon semiconductor target. In that case also, it is preferable that remaining moisture be removed from a deposition chamber in the formation of the protective insulating layer **506** as in the case of the insulating layer **516**.

[0293] After the formation of the protective insulating layer, heat treatment may be further performed at a temperature from 100° C. to 200° C. inclusive in the air for 1 hour to 30 hours inclusive. This heat treatment may be performed at a fixed heating temperature. Alternatively, the following change in the heating temperature may be conducted plural times repeatedly: the heating temperature is increased from room temperature to a temperature of 100° C. to 200° C. inclusive and then decreased to room temperature.

[0294] A transistor including a highly purified oxide semiconductor layer which is manufactured in accordance with this embodiment as described achieves high field-effect mobility and thus can operate at high speed. When the transistor including a highly purified oxide semiconductor layer is used in a pixel portion in the liquid crystal display device, color separation can be suppressed and a high-

quality image can be provided. In addition, by using the transistors including a highly purified oxide semiconductor layer, a driver circuit portion and a pixel portion are formed over one substrate; thus, the number of components of the liquid crystal display device can be reduced.

[0295] Measurement results of the field-effect mobility of a transistor including a highly purified oxide semiconductor are described.

[0296] In accordance with the above manufacturing method of this embodiment, a transistor ($L/W=10\ \mu\text{m}/50\ \mu\text{m}$) including a highly purified oxide semiconductor (an In—Ga—Zn—O-based oxide semiconductor film with a thickness of 50 nm) was manufactured, and a change in characteristics of source-drain current (hereinafter, referred to as drain current or I_d) was measured under conditions that the substrate temperature was set to room temperature, source-drain voltage (hereinafter, referred to as drain voltage or V_d) was set to 10 V, and source-gate voltage (hereinafter, referred to as gate voltage or V_g) was changed from $-30\ \text{V}$ to $+30\ \text{V}$. That is, V_g - I_d characteristics were measured. Note that in FIG. 14, the range of V_g is from $-5\ \text{V}$ to $+30\ \text{V}$. From FIG. 14, the maximum value of field-effect mobility of the transistor including a highly purified oxide semiconductor layer can be confirmed to be $10.7\ \text{cm}^2/\text{Vsec}$.

[0297] Further, the transistor including a highly purified oxide semiconductor can achieve further a reduction in the current value in an off state (off-current value). Therefore, the holding period of an electric signal of an image signal or the like can be extended and an interval between writing operations can be set longer. Thus, the frequency of refresh operation can be reduced, whereby a decrease in consumed power can be more effectively improved.

[0298] In addition, measurement results of the off current of a transistor including a highly purified oxide semiconductor are described.

[0299] In accordance with the above manufacturing method of this embodiment, a transistor including a highly purified oxide semiconductor was manufactured. First, a transistor with a sufficiently large channel width W of 1 cm was prepared in consideration of the very small off current of the transistor including a highly purified oxide semiconductor, and the off current was measured. FIG. 15 shows the measurement results of the off current of the transistor with a channel width W of 1 cm. In FIG. 15, the horizontal axis indicates the gate voltage V_g and the vertical axis indicates the drain current I_d . In the case where the drain voltage V_d is $+1\ \text{V}$ or $+10\ \text{V}$, the off current of the transistor with the gate voltage V_g within the range of $-5\ \text{V}$ to $-20\ \text{V}$ was found to be smaller than or equal to $1 \times 10^{-13}\ \text{A}$ which is the detection limit. Moreover, it was found that the off current of the transistor (per unit channel width ($1\ \mu\text{m}$)) was smaller than or equal to $10\ \text{aA}/\mu\text{m}$ ($1 \times 10^{-17}\ \text{A}/\mu\text{m}$).

[0300] Next, more accurate measurement results of the off current of the transistor including a highly purified oxide semiconductor are described. As described above, the off current of the transistor including a highly purified oxide semiconductor was found to be smaller than or equal to $1 \times 10^{-13}\ \text{A}$ which is the detection limit of measurement equipment. Thus, more accurate off current (the value smaller than or equal to the detection limit of measurement equipment in the above measurement) was measured with use of a test element group (TEG). The results thereof will be described.

[0301] The test element group used in the current measurement is described below.

[0302] As the test element group, three measurement systems which are connected in parallel are used. Each measurement system includes a capacitor, a first transistor, a second transistor, a third transistor, and a fourth transistor. The first to fourth transistors were manufactured in accordance with this embodiment, and each transistor had the same structure as the transistor 510 illustrated in FIG. 13D.

[0303] In each measurement system, one of a source terminal and a drain terminal of the first transistor, one of terminals of the capacitor, and one of a source terminal and a drain terminal of the second transistor are connected to a power supply (for supplying V2). The other of the source terminal and the drain terminal of the first transistor, one of a source terminal and a drain terminal of the third transistor, the other of the terminals of the capacitor, and a gate terminal of the second transistor are connected to one another. The other of a source terminal and a drain terminal of the third transistor, one of a source terminal and a drain terminal of the fourth transistor, and a gate terminal of the fourth transistor are connected to a power supply (for supplying V1). The other of the source terminal and the drain terminal of the second transistor, the other of the source terminal and the drain terminal of the fourth transistor are connected to an output terminal.

[0304] A potential V_{ext_b2} for controlling whether to turn on or off the first transistor is supplied to the gate terminal of the first transistor. A potential V_{ext_b1} for controlling whether to turn on or off the third transistor is supplied to the gate terminal of the third transistor. A potential V_{out} is output from the output terminal.

[0305] Then, the measurement of the off current with use of the above measurement systems is described.

[0306] In order to measure the off current, the potential difference is applied in an initialization period, and after a measurement period is started, potential of the gate terminal of the second transistor varies over time. Accordingly, potential of the output potential V_{out} of the output terminal varies over time. Then, the off current can be calculated with the thus obtained output potential V_{out} .

[0307] Each of the first to fourth transistors is a transistor including a highly purified oxide semiconductor with a channel length L of $10\ \mu\text{m}$ and a channel width W of $50\ \mu\text{m}$. In the three measurement systems arranged in parallel, the capacitance value of the capacitor in the first measurement system was 100 fF, the capacitance value of the capacitor in the second measurement system was 1 pF, and the capacitance value of the capacitor in the third measurement system was 3 pF.

[0308] Note that V_{dd} was 5 V and V_{ss} was 0 V in the measurement of the off current. In the measurement period, V_{out} was measured for a period of 100 msec only during which V1 was set to V_{dd} while the potential V1 was basically set to V_{ss} . The measurements were conducted every 10 to 300 seconds. Further, Δt used in calculation of current I which flows through the element was about 30000 sec.

[0309] FIG. 16 shows the off current which was calculated in the above current measurement. FIG. 16 further shows the relationship between source-drain voltage V and off current I . According to FIG. 16, the off current was about $40\ \text{zA}/\mu\text{m}$ under the condition that the source-drain voltage was 4 V. In addition, the off current was less than or equal to $10\ \text{zA}/\mu\text{m}$

under the condition that the source-drain voltage was 3.1 V. Note that 1 zA represents 10^{-21} A.

[0310] According to this embodiment, it was confirmed that the off current can be sufficiently small in a transistor including a highly purified oxide semiconductor.

Embodiment 6

[0311] In this embodiment, with the use of a display device which switches an image for a left eye and an image for a right eye at high speed, an example in which a 3D image which is a moving image or a still image is seen with dedicated glasses with which videos of the display device are synchronized is described with reference to FIGS. 17A and 17B.

[0312] FIG. 17A illustrates an external view in which a display device 2711 and dedicated glasses 2701 are connected to each other with a cable 2703. In the dedicated glasses 2701, shutters provided in a panel 2702a for a left eye and a panel 2702b for a right eye are alternately opened and closed, whereby a user can see an image of the display device 2711 as a 3D image.

[0313] In addition, FIG. 17B is a block diagram illustrating a main structure of the display device 2711 and the dedicated glasses 2701.

[0314] The display device 2711 illustrated in FIG. 17B includes a display control circuit 2716, a display portion 2717, a timing generator 2713, a source line driver circuit 2718, an external operation unit 2722, and a gate line driver circuit 2719. Note that an output signal changes in accordance with operation by the external operation unit 2722 such as a keyboard.

[0315] In the timing generator 2713, a start pulse signal and the like are formed, and a signal for synchronizing an image for a left eye and the shutter of the panel 2702a for a left eye, a signal for synchronizing an image for a right eye and the shutter of the panel 2702b for a right eye, and the like are formed.

[0316] A synchronization signal 2731a of the image for a left eye is input to the display control circuit 2716, so that the image for a left eye is displayed on the display portion 2717. At the same time, a synchronization signal 2730a for opening the shutter of the panel 2702a for a left eye is input to the panel 2702a for a left eye. In addition, a synchronization signal 2731b of the image for a right eye is input to the display control circuit 2716, so that the image for a right eye is displayed on the display portion 2717. At the same time, a synchronization signal 2730b for opening the shutter of the panel 2702b for a right eye is input to the panel 2702b for a right eye.

[0317] Since an image for a left eye and an image for a right eye are switched at high speed, the display device 2711 preferably employs a successive color mixing method (a field sequential method) in which color display is performed by time division with use of light-emitting diodes (LEDs).

[0318] Further, since a field sequential method is employed, it is preferable that the timing generator 2713 input the synchronization signals 2730a and 2730b to the backlight portion of the light-emitting diodes. Note that the backlight portion includes LEDs of R, G, and B colors.

[0319] This embodiment can be combined with any of the other embodiments in this specification as appropriate.

Embodiment 7

[0320] A liquid crystal display device disclosed in this specification can be applied to a variety of electronic devices (including game machines). Examples of electronic devices are a television set (also referred to as a television or a television receiver), a monitor of a computer or the like, a camera such as a digital camera or a digital video camera, a digital photo frame, a mobile phone handset (also referred to as a mobile phone or a mobile phone device), a portable game machine, a portable information terminal, an audio reproducing device, a large-sized game machine such as a pachinko machine, and the like. Examples of electronic devices each including the liquid crystal display device described in any of the above embodiments are described.

[0321] FIG. 18A illustrates an electronic book reader (also referred to as an e-book reader), which includes a housing 9630, a display portion 9631, operation keys 9632, a solar cell 9633, and a charge and discharge control circuit 9634. The e-book reader illustrated in FIG. 18A has a function of displaying various kinds of information (e.g., a still image, a moving image, and a text image) on the display portion, a function of displaying a calendar, a date, the time, or the like on the display portion, a function of operating or editing the information displayed on the display portion, a function of controlling processing by various kinds of software (programs), and the like. Note that, in FIG. 18A, the charge and discharge control circuit 9634 has a battery 9635 and a DCDC converter (hereinafter, abbreviated as a converter) 9636 as an example. When the liquid crystal display device described in any of Embodiments 1 to 6 is applied to the display portion 9631, an e-book reader which consumes less power can be provided.

[0322] In the case of using a transreflective or reflective liquid crystal display device as the display portion 9631 in the structure illustrated in FIG. 18A, the e-book reader is assumed to be used in a comparatively bright environment. In that case, power generation by the solar cell 9633 and charge by the battery 9635 can be effectively performed, which is preferable. Since the solar cell 9633 can be provided on a space (a surface or a rear surface) of the housing 9630 as appropriate, the battery 9635 can be efficiently charged, which is preferable. Note that using a lithium ion battery as the battery 9635 has the advantage of downsizing can be achieved, for example.

[0323] A configuration and operation of the charge and discharge control circuit 9634 illustrated in FIG. 18A is described with reference to a block diagram of FIG. 18B. FIG. 18B shows the solar cell 9633, the battery 9635, the converter 9636, a converter 9637, switches SW1 to SW3, and the display portion 9631. The charge and discharge control circuit 9634 includes the battery 9635, the converter 9636, the converter 9637, and the switches SW1 to SW3.

[0324] First, an example of operation of when the solar cell 9633 generates power by using external light is described. The power generated by the solar cell is raised or lowered by the converter 9636 to be the voltage which is stored in the battery 9635. When the power from the solar cell 9633 is used for operation of the display portion 9631, the switch SW1 is turned on and the power is raised or lowered by the converter 9637 to be the voltage needed for the display portion 9631. When display is not performed on the display portion 9631, the switch SW1 may be turned off and the switch SW2 may be turned on, whereby the battery 9635 is charged.

[0325] Next, an example of operation of when the solar cell 9633 does not generate power by using external light is described. The power stored in the battery 9635 is raised or lowered by the converter 9637 when the switch SW3 is turned on. Then, the power from the battery 9635 is used for operation of the display portion 9631.

[0326] Note that the solar cell 9633 is described as an example of a charging unit here; however, charging the battery 9635 may be performed by another unit. Alternatively, a combination of another charging unit may be used.

[0327] FIG. 19 illustrates a laptop personal computer, which includes a main body 3001, a housing 3002, a display portion 3003, a keyboard 3004, and the like. When the liquid crystal display device described in any of Embodiments 1 to 6 is applied to the display portion 3003, power consumption in a laptop personal computer can be small.

[0328] This embodiment can be implemented in appropriate combination with the structures described in the other embodiments.

[0329] This application is based on Japanese Patent Application serial no. 2010-012665 filed with Japan Patent Office on Jan. 24, 2010, the entire contents of which are hereby incorporated by reference.

1. (canceled)

2. A semiconductor device comprising:

a pixel portion comprising a transistor; and
a driver circuit electrically connected to the pixel portion, wherein, in a first mode, a start pulse is supplied to the driver circuit and a power supply voltage is supplied to the driver circuit, so as to display a first image,

wherein, in a second mode, the start pulse supplied to the driver circuit is stopped and the power supply voltage supplied to the driver circuit is lowered, so as to display a second image in which the writing frequency is lower than the first image, and

wherein the transistor comprises a channel formation region comprising an oxide semiconductor.

3. The semiconductor device according to claim 2, wherein the oxide semiconductor comprises indium, gallium, and zinc.

4. A semiconductor device comprising:

a pixel portion comprising a transistor; and
a driver circuit electrically connected to the pixel portion, wherein, in a first mode, a start pulse is supplied to the driver circuit and a power supply voltage is supplied to the driver circuit, so as to display a first image,

wherein, in a second mode, the start pulse supplied to the driver circuit is stopped and the power supply voltage supplied to the driver circuit is lowered, so as to display a second image in which the writing frequency is lower than the first image, and

wherein the transistor comprises a channel formation region comprising an oxide semiconductor, and

wherein, in the case where the drain voltage is +1 V or +10 V, the off current of the transistor with the gate voltage within a range of -5 V to -20 V is smaller than or equal to 1×10^{-13} A.

5. The semiconductor device according to claim 4, wherein the oxide semiconductor comprises indium, gallium, and zinc.

* * * * *

