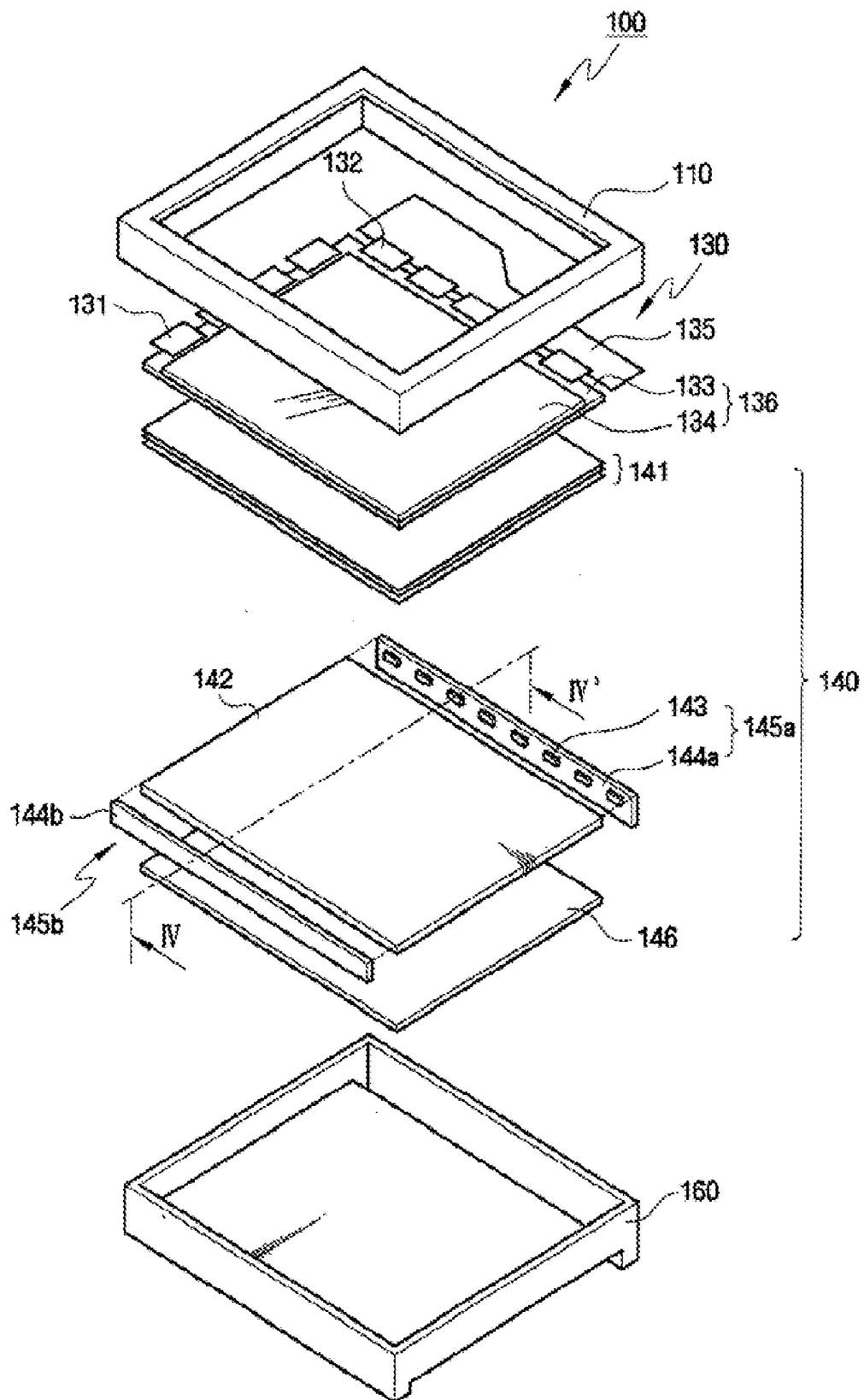



**FIG. 1**



**FIG. 2**

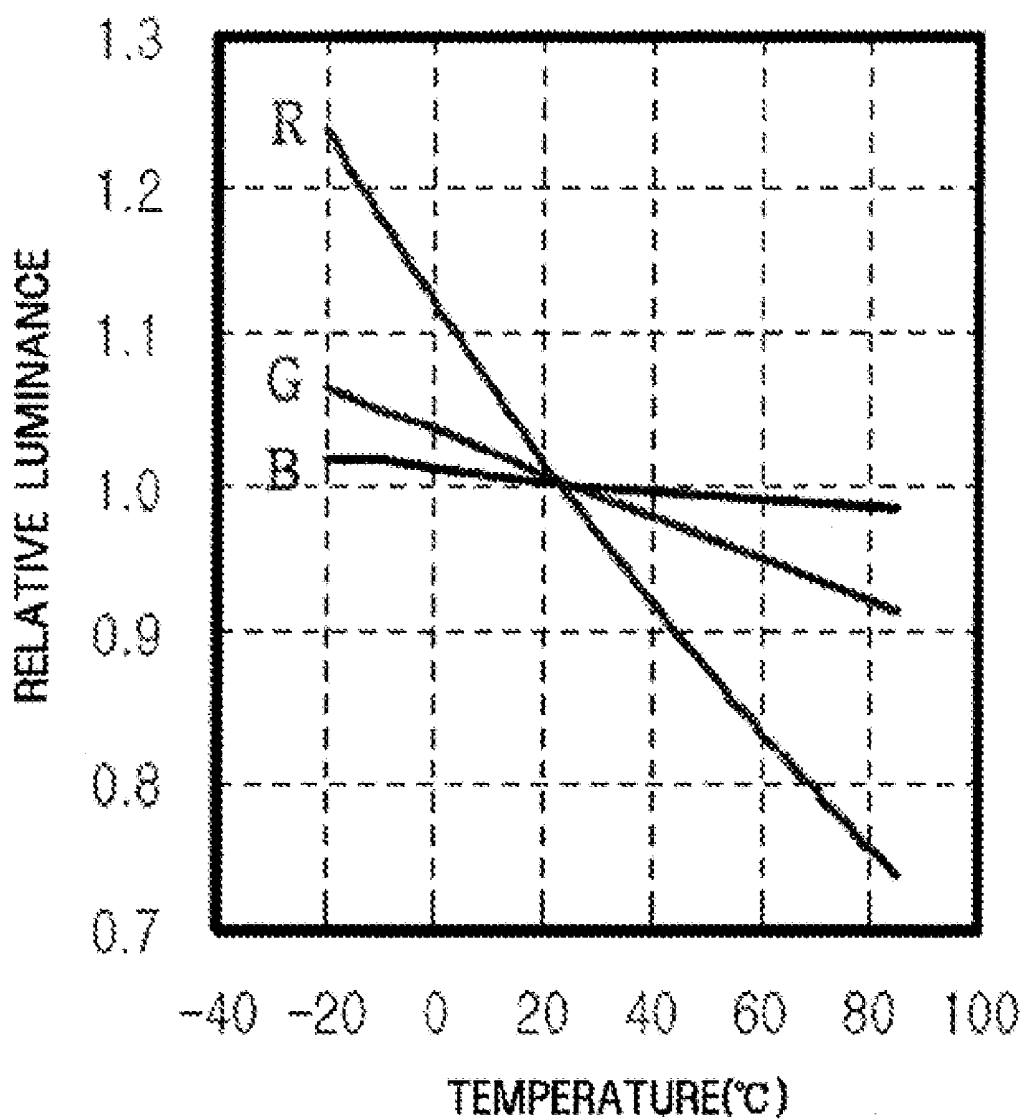

FIG. 3

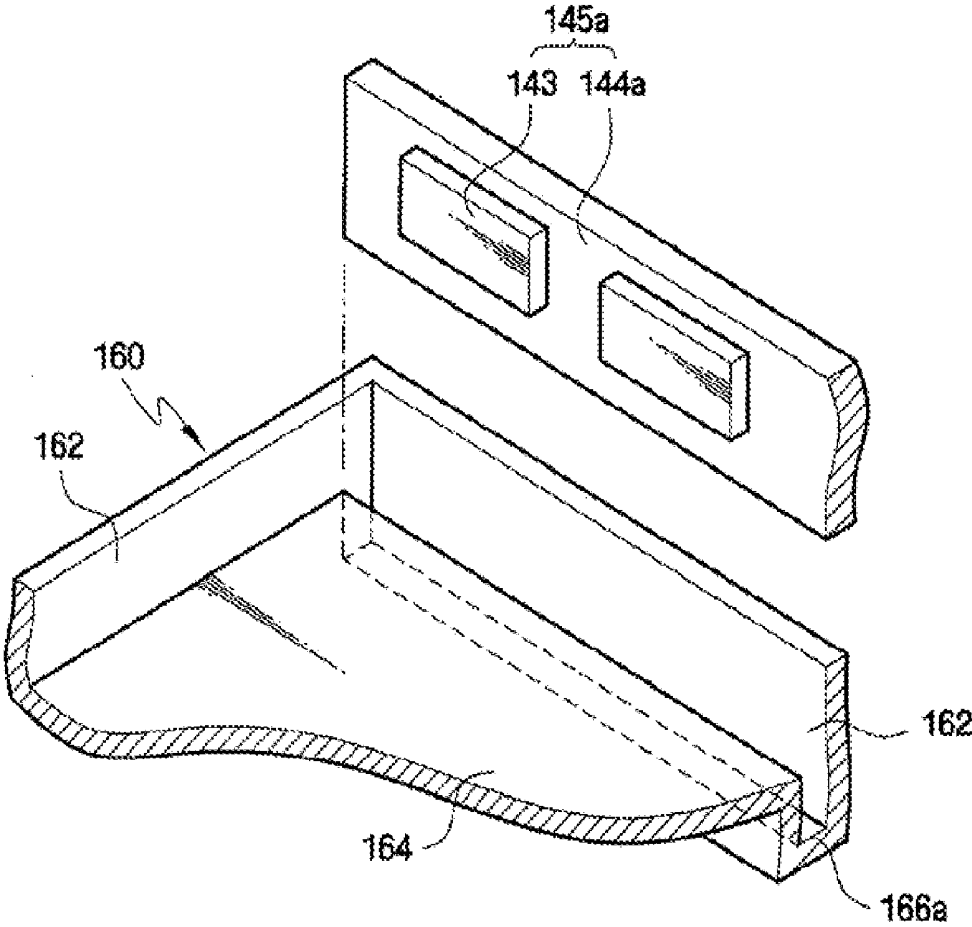

FIG. 4

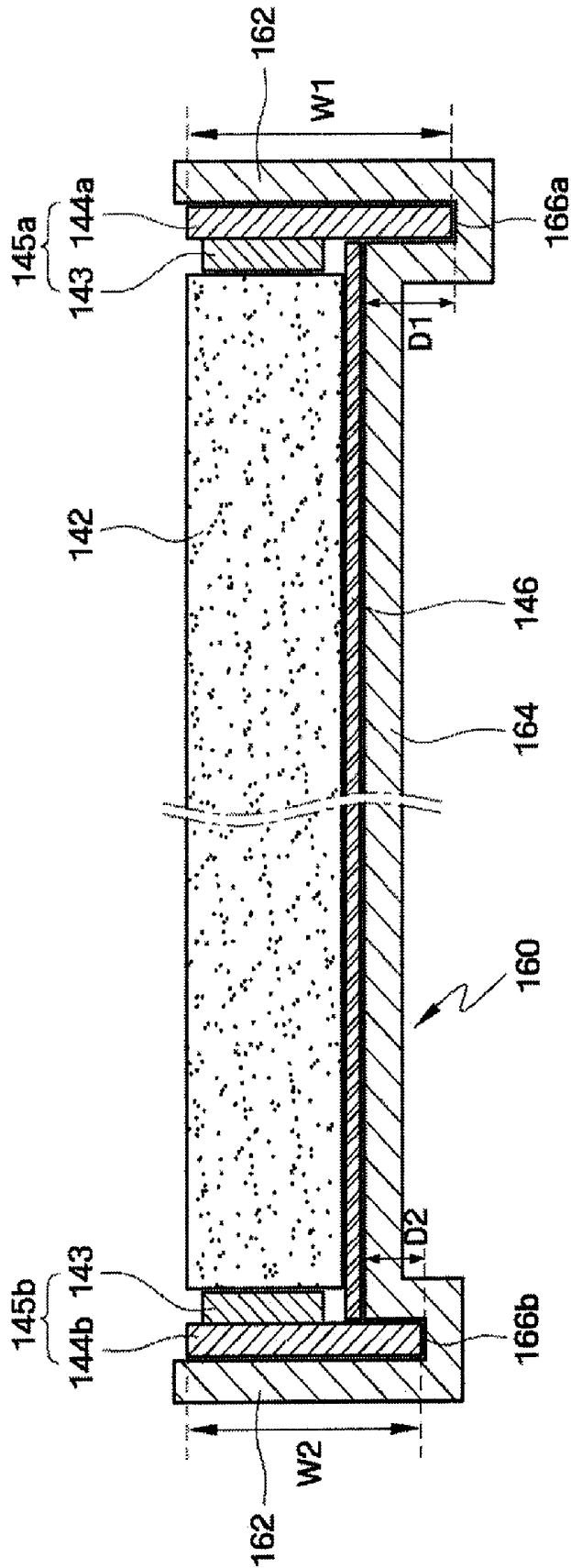

FIG. 5A

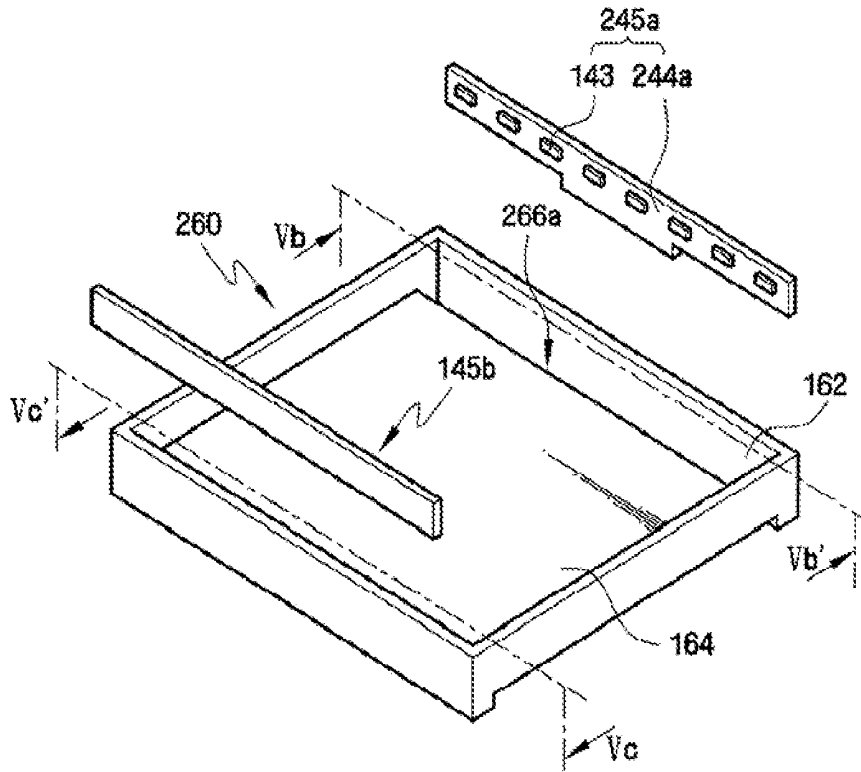

FIG. 5B

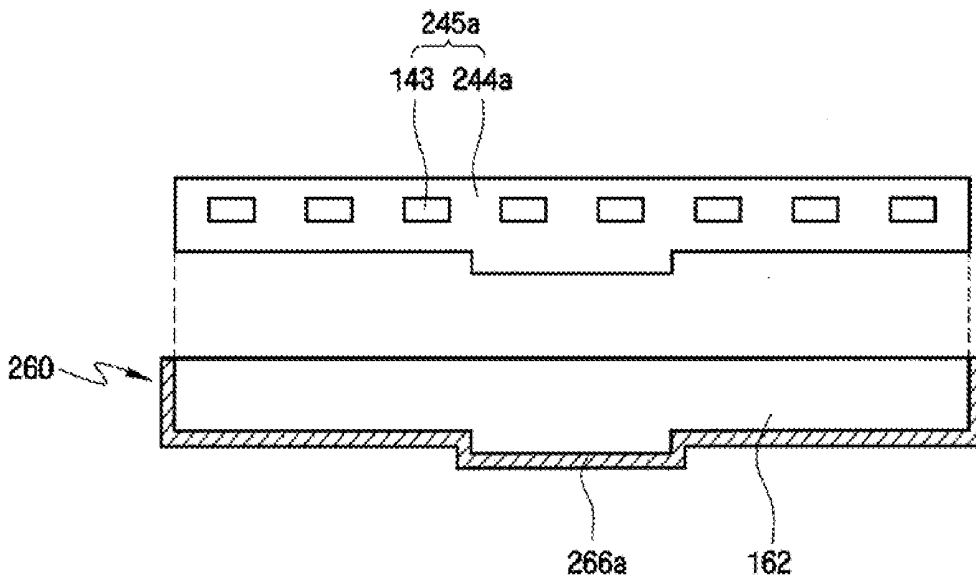

FIG. 5C

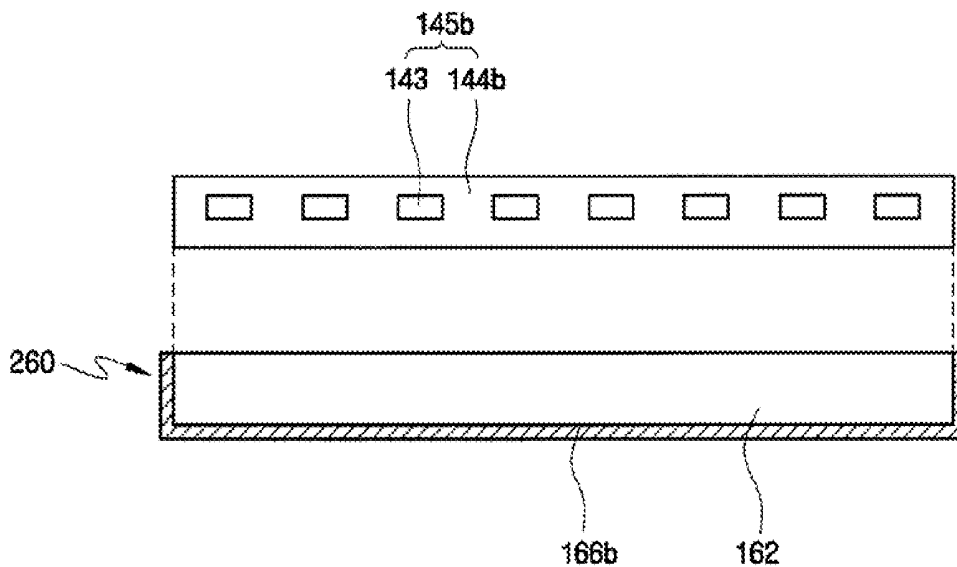
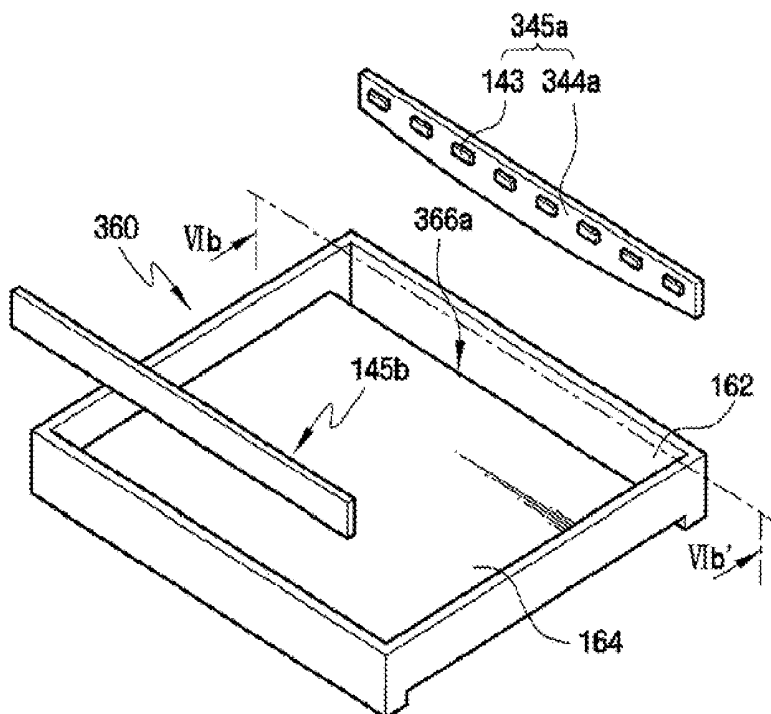
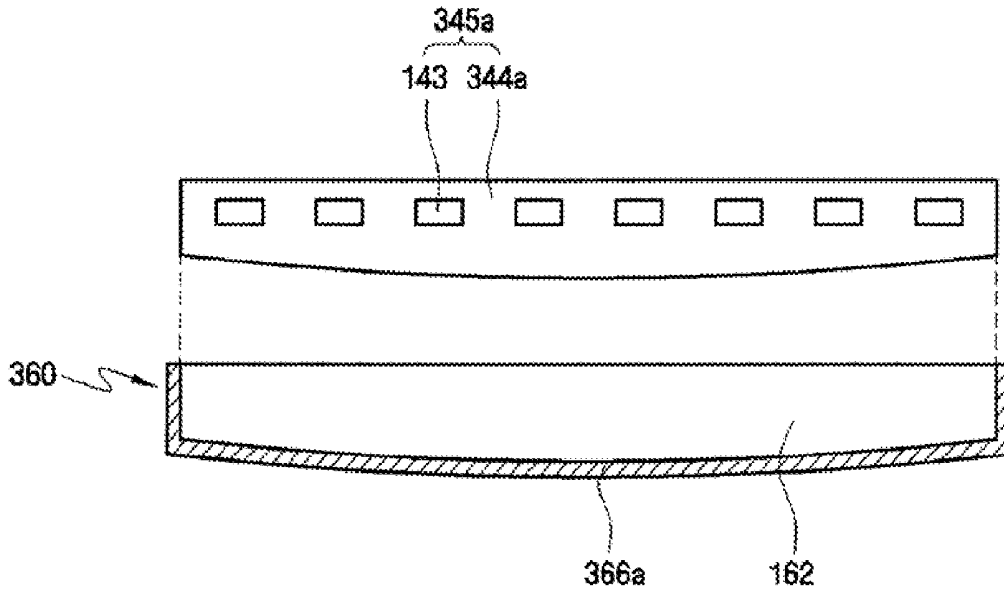

FIG. 6A



**FIG. 6B**



**FIG. 7A**

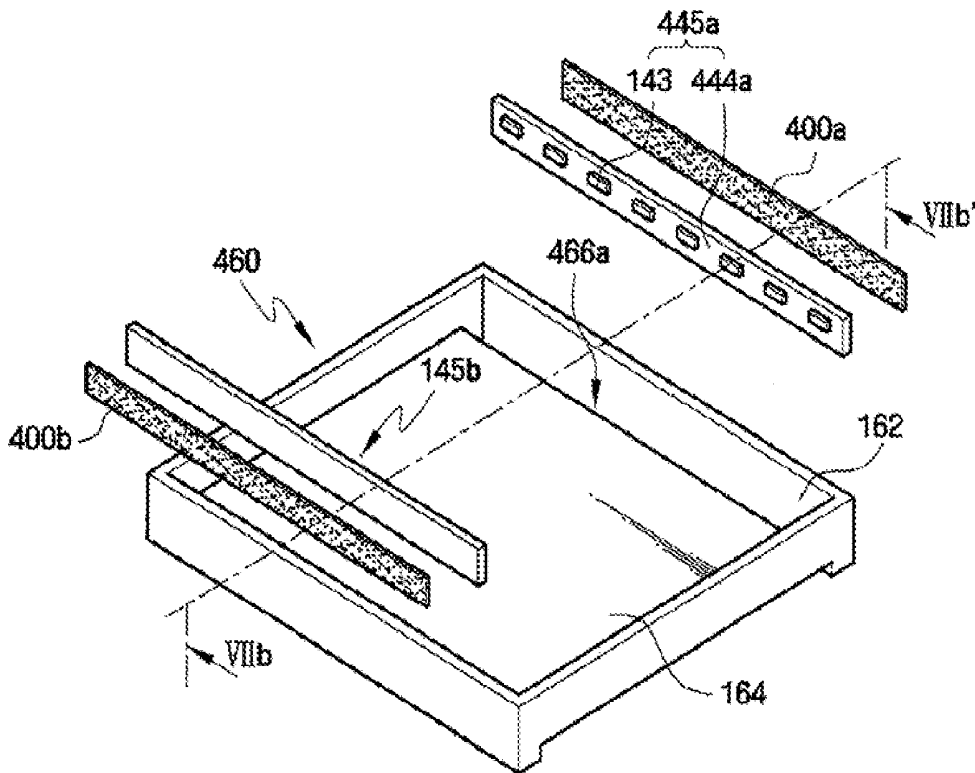

FIG. 7B

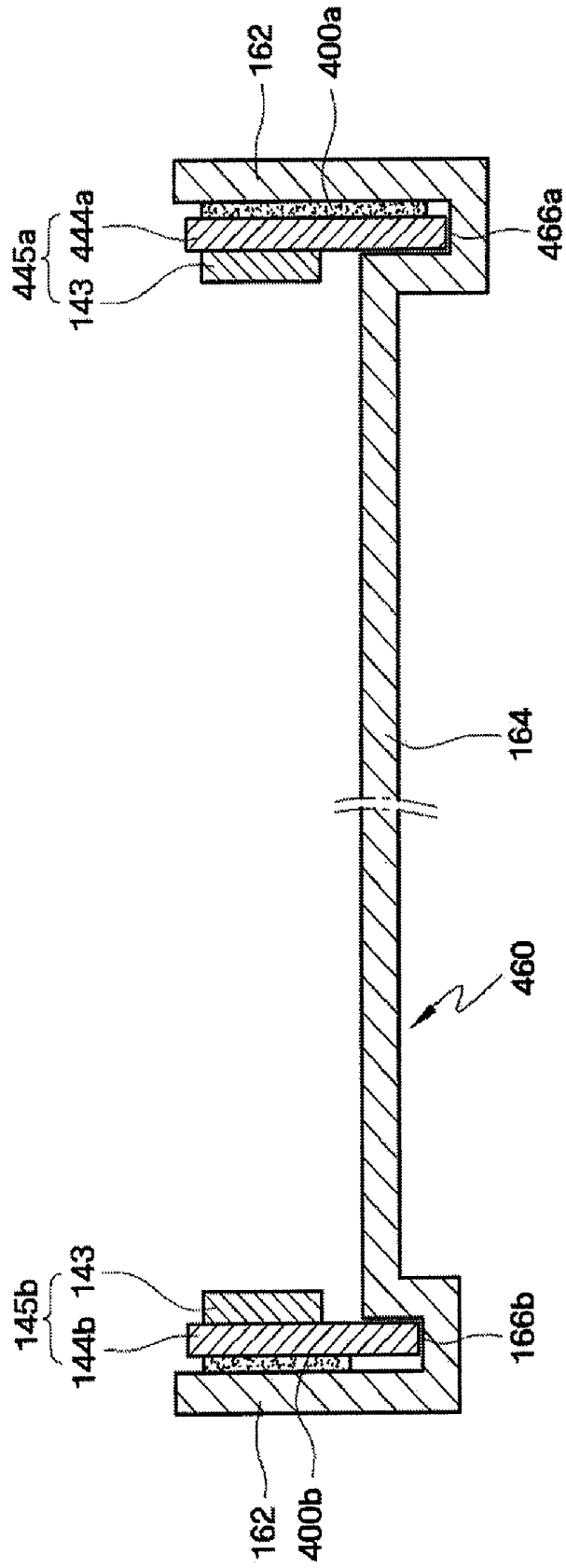

FIG. 8

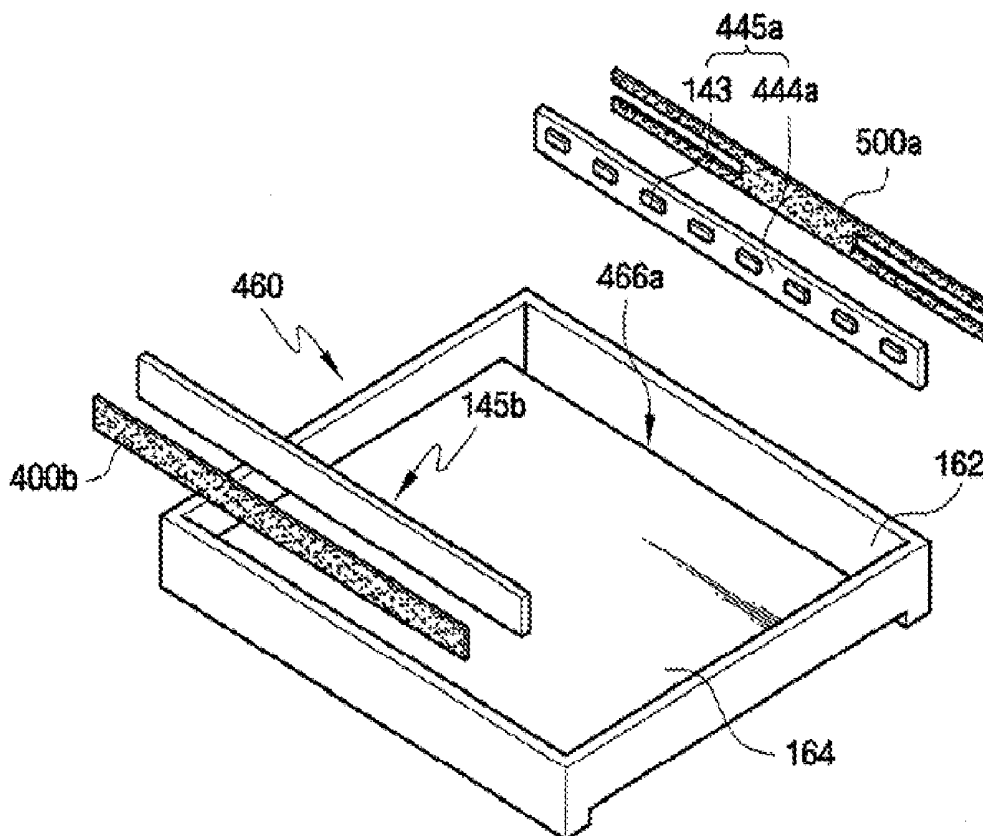

FIG. 9

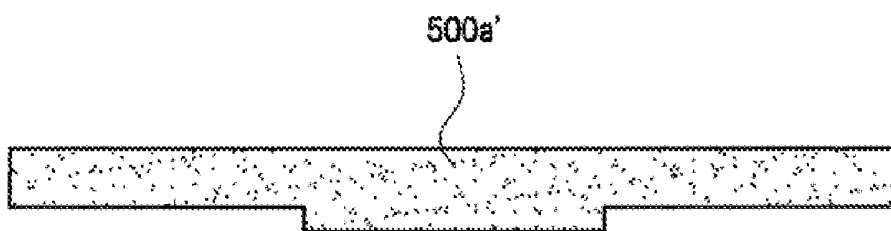

FIG. 10A

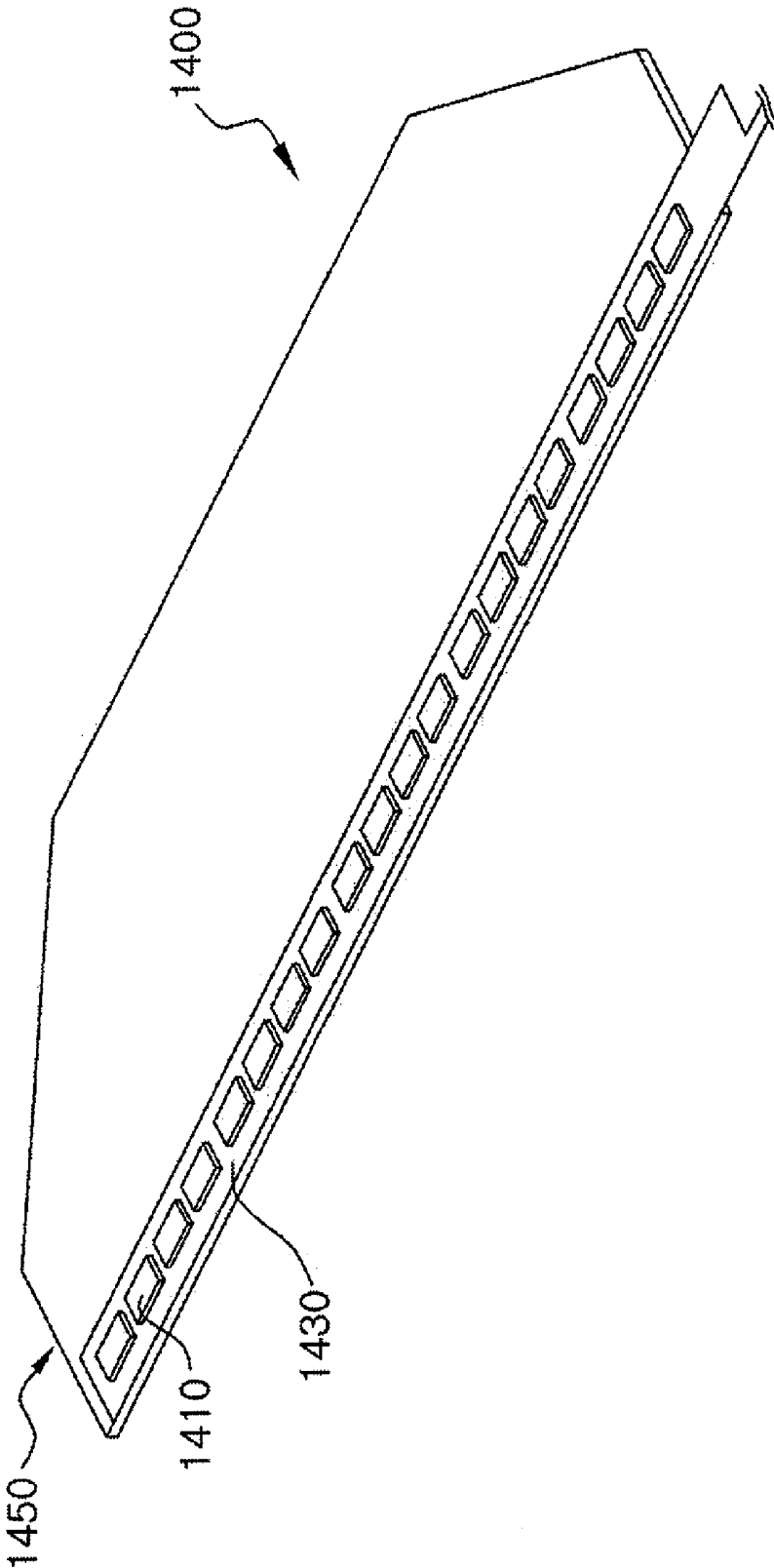



FIG. 11

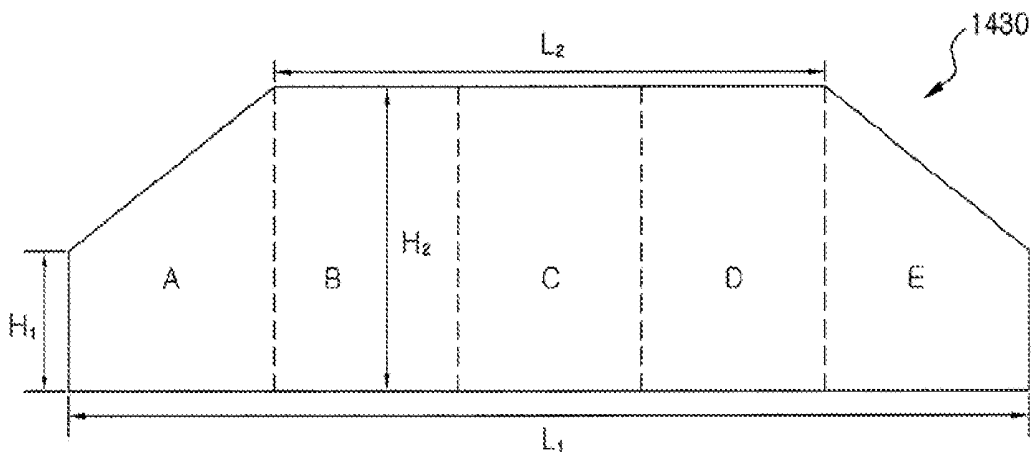
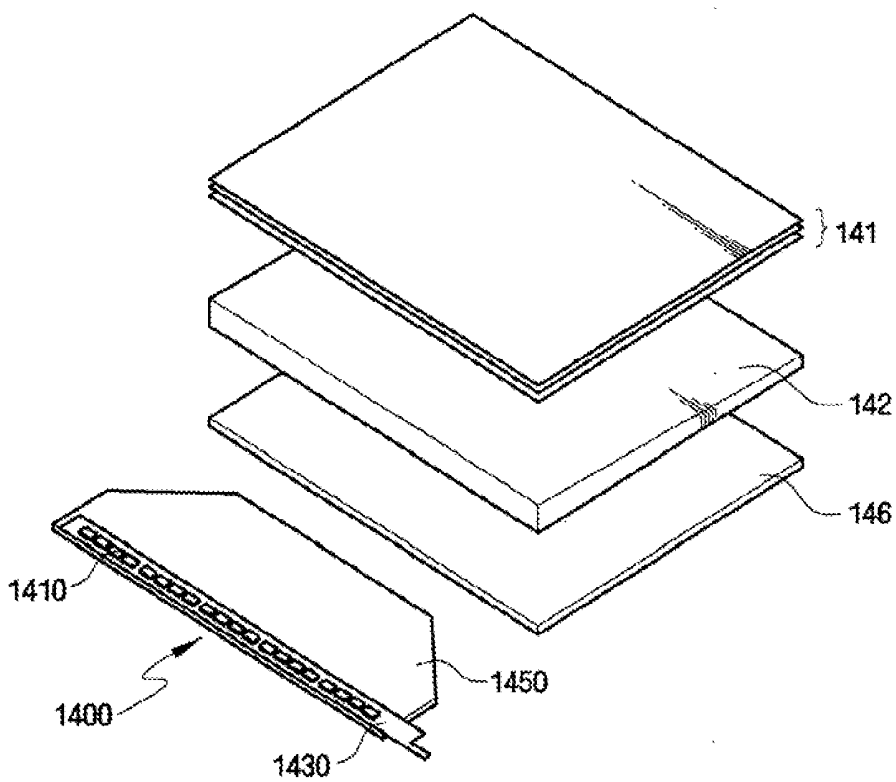
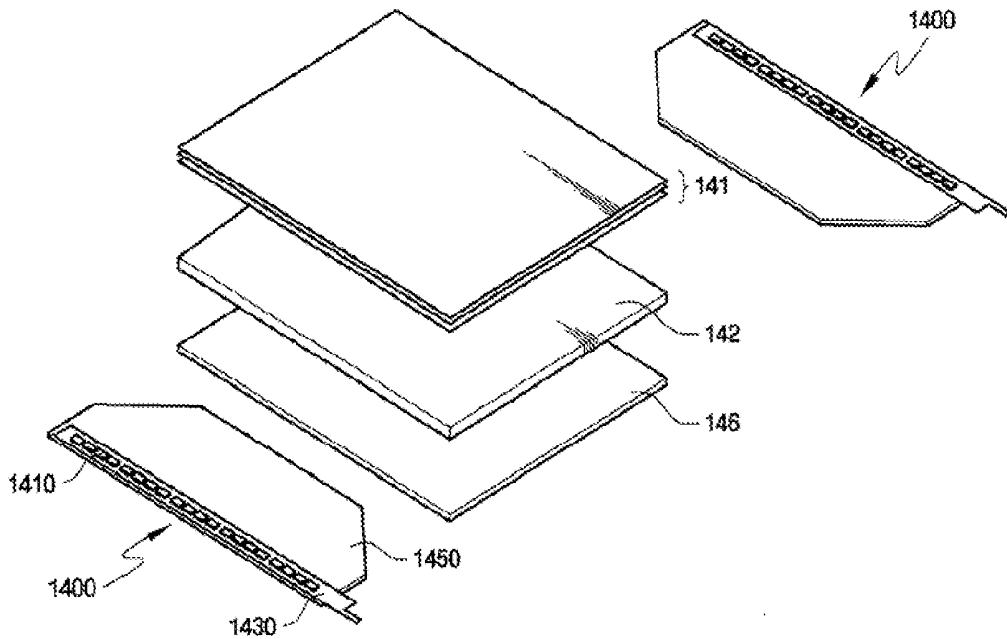

FIG. 12A



**FIG. 12B**



**FIG. 13**

BLU	LED		
	LEFT	CENTER	RIGHT
THE RELATED ART	44.4	47.4	42.2
THE PRESENT INVENTION	45.1	45.4	45.9

FIG. 14A

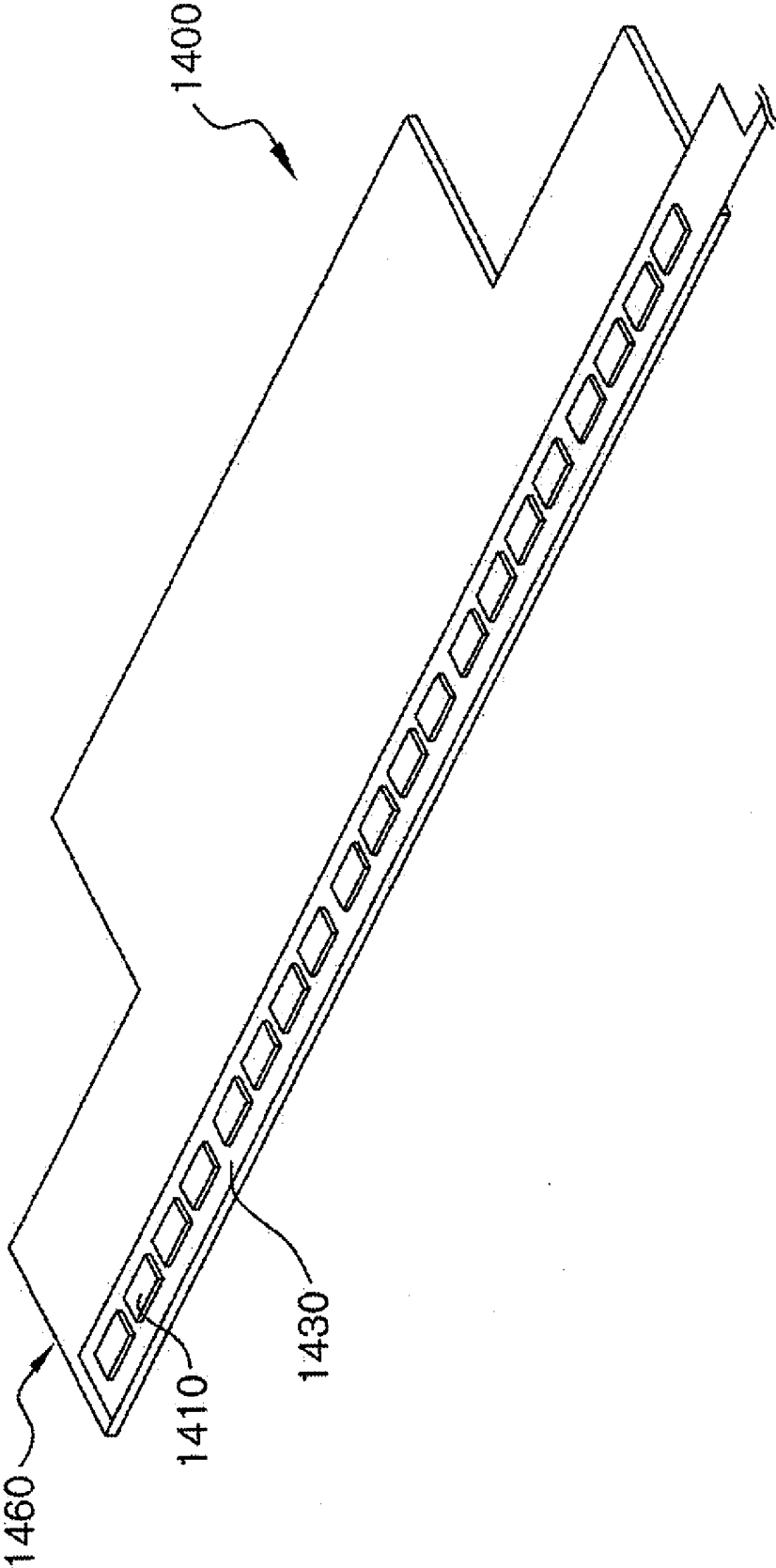
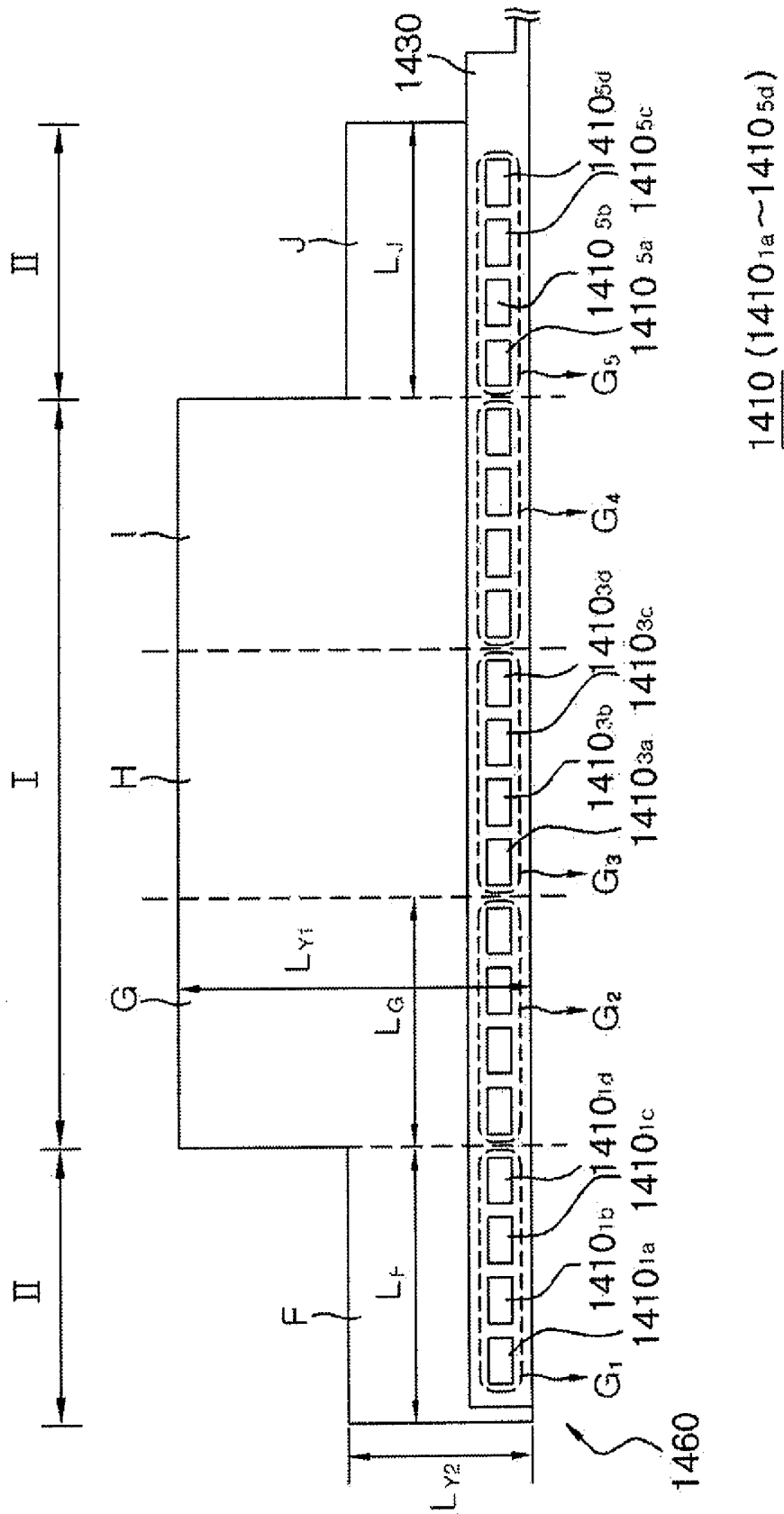

FIG. 14B



1410 (1410<sub>1a</sub>~1410<sub>5d</sub>)

## LIQUID CRYSTAL DISPLAY

### CROSS REFERENCE TO RELATED APPLICATIONS

**[0001]** This application is a divisional of U.S. patent application Ser. No. 11/944,012, filed on Nov. 21, 2007, which in turn claims priority from Korean Patent Application Nos. 10-2006-0115165 and 10-2006-0123917 filed on Nov. 21, 2006 and Dec. 7, 2006, respectively, the disclosures of which are incorporated herein by reference in their entireties.

### BACKGROUND OF THE INVENTION

**[0002]** 1. Technical Field

**[0003]** The present disclosure relates to a display, and more particularly to a liquid crystal display including a point light source assembly.

**[0004]** 2. Discussion of the Related Art

**[0005]** Liquid crystal displays are widely used flat panel displays. A liquid crystal display includes two substrates with electrodes and a liquid crystal layer interposed between the substrates. The liquid crystal display rearranges liquid crystal molecules in a liquid crystal layer by applying a voltage to electrodes to control the amount of light passing through the liquid crystal layer.

**[0006]** Because these liquid crystal molecules display images by changing light transmittance according to the direction and magnitude of an electromagnetic field, a liquid crystal display uses light for displaying images. Typical light sources used in liquid crystal displays are, for example, a light emitting diode (LED), a cold cathode fluorescent lamp (CCFL), and a flat fluorescent lamp (FFL).

**[0007]** LEDs have a characteristic of low power consumption and high luminance.

**[0008]** The emitting efficiency of the LEDs changes according to the change of a surrounding temperature. The change of emitting efficiency of the LEDs results in deterioration of display characteristics of liquid crystal displays. For example, the emitting efficiency of a red LED changes substantially according to changes in a surrounding temperature, and color spots appear due to decreased color uniformity for each region. The decrease in color uniformity occurs because the surrounding temperature is not uniform for each region of the liquid crystal display.

### SUMMARY OF THE INVENTION

**[0009]** According to an exemplary embodiment of the present invention, a liquid crystal display includes a light guide plate guiding incident light, a first point light source assembly which includes first point light source elements providing the light to the light guide plate and a first support substrate having the first point light source elements and is disposed at a side of the light guide plate, a second point light source assembly which includes second point light source elements providing the light to the light guide plate and a second support substrate having the second point light source elements and is disposed at the other side of the light guide plate, a liquid crystal panel assembly disposed on the light guide plate and displaying image information, and a lower container accommodating the light guide plate, first and second point light source assemblies, and liquid crystal panel assembly. The first support substrate can be larger than the second support substrate in area.

**[0010]** According to an exemplary embodiment of the present invention, a liquid crystal display includes a light guide plate guiding incident light, a first point light source assembly which includes first point light source elements providing the light to the light guide plate and a first support substrate equipped with the first point light source elements and is disposed at a side of the light guide plate, a second point light source assembly which includes second point light source elements providing the light to the light guide plate and a second support substrate having the second point light source elements and is disposed at the other side of the light guide plate, a liquid crystal panel assembly disposed on the light guide plate and displaying image information, a lower container accommodating the light guide plate, first and second point light source assemblies, and liquid crystal panel assembly, and first and second heat conductive pads interposed between the lower container and the first and second point light source assemblies, respectively. The first heat conductive pad can be larger than the second heat conductive pad in area.

**[0011]** According to an exemplary embodiment of the invention, a liquid crystal display includes a light guide plate guiding incident light, a point light source assembly including point light source elements providing the light to the light guide plate and a support substrate having groups of point light source element comprising at least one of the point light source elements, a lower container accommodating the light guide plate and point light source assembly, and a heat conductive pad interposed between the point light source assembly and the lower container. The heat conductive pad can include unit regions having the groups of point light source elements, and the unit regions include a first unit region and a second unit region wherein the first unit region and the second unit region are different in size.

### BRIEF DESCRIPTION OF THE DRAWINGS

**[0012]** Exemplary embodiments of the present invention can be understood in more detail from the following descriptions taken in conjunction with the accompanying drawings in which:

**[0013]** FIG. 1 is an exploded perspective view of a liquid crystal display according to an exemplary embodiment of the present invention;

**[0014]** FIG. 2 is a graph showing a luminance of an emitting chip in relation to a surrounding temperature;

**[0015]** FIG. 3 is a partial perspective cut-away view illustrating a first point light source assembly and a lower container according to an exemplary embodiment of the present invention;

**[0016]** FIG. 4 is a cross-sectional view of a liquid crystal display taken along the line IV-IV' of FIG. 1;

**[0017]** FIG. 5a is an exploded perspective view showing a point light source assembly and a lower container accommodating the point light source assembly included in a liquid crystal display according to an exemplary embodiment of the present invention;

**[0018]** FIG. 5b is a cross-sectional view of a point light source assembly and a lower container taken along the line Vb-Vb' of FIG. 5a;

**[0019]** FIG. 5c is a cross-sectional view of a point light source assembly and a lower container taken along the line Vc-Vc' of FIG. 5a;

**[0020]** FIG. 6a is an exploded perspective view showing a point light source assembly and a lower container accommo-

dating the point light source assembly included in a liquid crystal display according to an exemplary embodiment of the present invention;

[0021] FIG. 6*b* is a cross-sectional view of a point light source assembly and a lower container taken along the line VIIb-VIIb' of FIG. 6*a*;

[0022] FIG. 7*a* is an exploded perspective view of a point light source assembly and a lower container accommodating the point light source assembly included in a liquid crystal display according to an exemplary embodiment of the present invention;

[0023] FIG. 7*b* is a cross-sectional view of a point light source assembly and a lower container taken along the line VIIb-VIIb' of FIG. 7*a*;

[0024] FIG. 8 is an exploded perspective view of a point light source assembly and a lower container accommodating the point light source assembly according to an exemplary embodiment of the present invention;

[0025] FIG. 9 is a first heat conductive pad according to an exemplary embodiment of the present invention;

[0026] FIG. 10*a* is a perspective view of a point light source assembly included in a liquid crystal display according to an exemplary embodiment of the present invention;

[0027] FIG. 10*b* is a plan view of a point light source assembly according to an exemplary embodiment of the present invention;

[0028] FIG. 11 is a diagram of a heat conductive pad of a point light source assembly according to an exemplary embodiment of the present invention;

[0029] FIG. 12*a* is an exploded perspective view of a backlight unit having a point light source assembly according to an exemplary embodiment of the present invention;

[0030] FIG. 12*b* is a backlight unit according to an exemplary embodiment of the present invention;

[0031] FIG. 13 is a table illustrating heat dissipation effects of a point light source assembly;

[0032] FIG. 14*a* is a perspective view of a point light source assembly included in a liquid crystal display according to an exemplary embodiment of the present invention; and

[0033] FIG. 14*b* is a plan view of a point light source assembly according to an exemplary embodiment of the present invention.

#### DESCRIPTION OF EXEMPLARY EMBODIMENTS

[0034] The invention is described more fully hereinafter with reference to the accompanying drawings, in which exemplary embodiments of the invention are shown.

[0035] The invention may, however, be embodied in many different forms and should not be construed as limited to the exemplary embodiments set forth herein.

[0036] A liquid crystal display according to an exemplary embodiment of the invention is described with reference to FIGS. 1 to 4.

[0037] FIG. 1 is an exploded perspective view of a liquid crystal display according to an exemplary embodiment of the present invention.

[0038] Referring to FIG. 1, a liquid crystal display 100 according to an exemplary embodiment of the present invention includes a liquid crystal panel assembly 130, a backlight unit 140, an upper container 110, and a lower container 160.

[0039] The liquid crystal panel assembly 130 includes a liquid crystal panel 136 including a lower display substrate 133, an upper display substrate 134 and a liquid crystal layer

(not shown) inserted between the display substrates, a gate chip film package 131, a data chip film package 132, and a printed circuit board 135.

[0040] The liquid crystal panel 136 includes the lower display substrate 133 that includes gate lines (not shown), data lines (not shown), a thin film transistor array, pixel electrodes and the upper display substrate 134 that includes color filters, a black matrix, and a common electrode and faces the lower display substrate 133. The color filters and common electrode may be formed on the lower display substrate 133. The liquid crystal panel 136 displays image information.

[0041] The gate chip film package 131 is connected to each gate line (not shown) formed on the lower display substrate 133 and provides each gate line with gate driving signals. The data chip film package 132 is connected to each data line (not shown) formed on the lower display substrate 133 and provides each data line with data driving signals. The gate chip film package 131 and data chip film package 132 include a Tape Automated Bonding (TAB) tape with a semiconductor chip bonded with a wiring pattern formed on a base film by Tape Automated Bonding (TAB). For example, for the gate and data chip film packages 131, 132, a tape carrier package (TCP) or a chip on film (COF) can be used according to an exemplary embodiment of the present invention.

[0042] The printed circuit board 135 is mounted with a variety of driving elements that process gate driving signals inputted into the gate chip film package 131 and data driving signals inputted into the data chip film package 132. The printed circuit board 135 is connected with the liquid crystal panel 136 and provides image information to the liquid crystal panel 136.

[0043] The backlight unit 140 includes optical sheets 141, a light guide plate 142, first and second point light source assemblies 145*a*, 145*b*, and a reflecting sheet 146.

[0044] The light guide plate 142 guides light supplied from the first and second point light source assemblies 145*a*, 145*b* to the liquid crystal panel 136. The light guide plate 142 comprises a plate of a transparent material. For example, an acrylic resin, such as PolyMethyl MethAcrylate (PMMA), or polycarbonate can be used as the light guide plate 142. When incident light through a side of the light guide plate 142 reaches the upper or lower surface of the light guide plate 142 over the critical angle of the light guide plate 142, the incident light is reflected from the surface of the light guide plate 142 and transmitted throughout the inside of the light guide plate 142 without leakage.

[0045] A diffusion pattern (not shown) is formed on at least one of the upper and lower surfaces of the light guide plate 142 to guide the light inside the light guide plate 142 to travel to the liquid crystal panel 136 disposed on the light guide plate 142. In an exemplary embodiment, a diffusion pattern may be formed on the lower surface of the light guide plate 142. That is, the light inside the light guide plate 142 is reflected from the diffusion pattern and travels outside through the upper surface of the light guide plate 142. The diffusion pattern formed on a surface of the light guide plate 142 may change in size and density according to the distance from the first and second point light source assemblies 145*a*, 145*b* to maintain the light traveling outside through the entire surface of the light guide plate 142 uniform in luminance. For example, the larger the distance from the first and second point light source assemblies 145*a*, 145*b*, the larger the density or size of the diffusion pattern, so that the light traveling outside through the entire surface can be uniform.

[0046] The diffusion pattern may be formed by, for example, a silk screen printing of ink. A diffusion pattern that has substantially the same operational effect may be formed by forming fine grooves or protrusions on the light guide plate 142.

[0047] The first and second point light source assemblies 145a, 145b are disposed at both sides of the light guide plate 142. In an exemplary embodiment, the light guide plate 142 can be formed, for example, in a flat plate shape with a substantially uniform thickness to uniformly transmit light throughout the display.

[0048] The first point light source assembly 145a supplies light to the liquid crystal panel 136 that is a passive light emitting component. The first point light source assembly 145a includes a plurality of point light source elements 143 and a first support substrate 144a having the point light source elements 143 disposed thereon. The second point light source assembly 145b supplies light to the liquid crystal panel 136. The second point light source assembly 145b includes a plurality of point light source elements (not shown) and a second support substrate 144b having the point light source elements. The first point light source assembly 145a is disposed on a first inside of the lower container 160 that is close to the data chip film package 132. The second point light source assembly 145b is disposed on a second inside facing the first inside of the lower container 160.

[0049] The point light source elements 143 are formed on sides of the first and second support substrates 144a, 144b at regular intervals by contact terminals. The first and second support substrates 144a, 144b may be formed into a long rectangular plate. For example, the first and second support substrates 144a, 144b may be formed of a printed circuit board (PCB) or a flexible printed circuit board (FPC).

[0050] Each of the point light source elements 143 includes a light emitting element that emits light, for example, directly. For example, the point light source element 143 may be an LED, an incandescent lamp, and a white halogen lamp. Each of the point light source element 143 includes a frame (not shown) and red, green, and blue light emitting chips disposed inside the frame. White light is produced by mixing red, green, and blue light emitted from each light emitting chip.

[0051] FIG. 2 is a graph that shows a luminance of light emitting chips in relation to a surrounding temperature. The relative luminance is based on the luminance of light radiated from the light emitting chips at a temperature of about 25° C.

[0052] As shown in FIG. 2, relative luminance of a red light emitting chip R rapidly changes with respect to temperature as compared with a green light emitting chip G and blue light emitting chip B. The point light source element 143 comprises the red, green, and blue light emitting chips R, G, B. When temperatures are different at each region where the point light source elements 143 are disposed, color scheme of red, green, and blue light radiated from each point light source element 143 varies, which reduces color uniformity.

[0053] Referring to FIG. 1, the reflecting sheet 146 is disposed under the light guide plate 142 and reflects light that travels down out of the light guide plate 142 upwardly. The reflecting sheet 146 reduces loss of light entering the liquid crystal panel 136 and improves color uniformity of light passing through the exit surface of the light guide plate 142 by reflecting light, which is not reflected by the diffusion pattern on a side of the light guide plate 142, to the exit surface of the light guide plate 142.

[0054] For example, the reflecting sheet 146 may comprise polyethylene terephthalate (PET) and a side of the reflecting sheet 146 may be coated with a diffusion layer that contains, for example, titanium dioxide. As titanium dioxide is dried and fixed, light can be more uniformly diffused by a white surface of frost formed by the titanium dioxide and predetermined reflective effect is achieved.

[0055] The optical sheets 141, disposed on the upper surface of the light guide plate 142, diffuse and concentrate light transmitted from the light guide plate 142. The optical sheets 141 include, for example, a diffusion sheet, a prism sheet, and a protection sheet. Disposed between the light guide plate 142 and the prism sheet, the diffusion sheet prevents a partial concentration of light by distributing light from the light guide plate 142. The prism sheet has an upper surface with a predetermined array of triangular prisms and may comprise, for example, two sheets. The prism arrays that cross with each other at a predetermined angle concentrate light diffused from the diffusion sheet perpendicularly to the liquid crystal panel 136. Accordingly, most light passing through the prism sheet perpendicularly travels and luminance is uniformly distributed on the protection sheet. The protection sheet, formed on the prism sheet, protects the surface of the prism sheet, and diffuses light to uniformly distribute the light. Configuration of the optical sheets 141 is not limited to the above and may be variously modified.

[0056] The liquid crystal panel 136 is formed on the protection sheet and placed inside the lower container 160 together with the backlight unit 140. The lower container 160 has sides formed along the edge of the bottom (see 164 in FIG. 3). The lower container 160 accommodates the backlight unit 140 and the liquid crystal panel assembly 130 inside the sides. The lower container 160 prevents the backlight unit 140 with a plurality of sheets from being bent. The printed circuit board 135 of the liquid crystal panel assembly 130 is bent and placed onto the outside of a side of the lower container 160, e.g., a rear side of the lower container 160. The lower container 160 may have a variety of shapes, depending on, for example, the ways of disposing the backlight unit 140 or the liquid crystal panel assembly 130 into the lower container 160.

[0057] The upper container 110 is combined with the lower container 160. The upper container 110 covers the upper surface of the liquid crystal panel assembly 130 placed in the lower container 160. A window is formed on the upper surface of the upper container 110 to expose the liquid crystal panel assembly 130 to the outside.

[0058] The upper container 110 may be combined with the lower container 160 by, for example, hooks (not shown). In an exemplary embodiment, the hooks are formed on the outsides of the sides of the lower container 160 and corresponding hook-inserting holes (not shown) are formed in the sides of the upper container 110. Accordingly, when the upper container 110 and the lower container 160 are combined by moving the upper container 110 down over the lower container 160, the hooks of the lower container 160 are inserted into the hook-inserting holes of the upper container 110 and the upper container 110 is fastened with the lower container 160. The upper container 110 and lower container 160 may be combined in a variety of ways.

[0059] FIG. 3 is a partial perspective cut-away view illustrating the first point light source assembly 145a and the lower container 160 according to an exemplary embodiment

of the present invention. FIG. 4 is a cross-sectional view of a liquid crystal display taken along the line IV-IV' in FIG. 1.

[0060] Referring to FIGS. 3 and 4, as described above, the lower container 160 has sides 162 formed along the edge of the bottom 164. A first groove 166a and a second groove 166b are formed on the bottom 164 along two sides 162. The first and second point light source assemblies 145a, 145b are inserted in the first groove 166a and second groove 166b, respectively. The first and second support substrates 144a, 144b are inserted into the first and second grooves 166a, 166b, respectively, close to the sides 162 of the lower container 160.

[0061] The first point light source assembly 145a is disposed adjacent to the side 162 of the lower container 160, close to the data chip film package 132, and the second point light source assembly 145b is disposed adjacent to the opposite side to the first point light source assembly 145a. The region around the first point light source assembly 145a is higher in temperature than the region adjacent to the second point light source assembly 145b due to the heat generated by a driving IC (integrated circuit) (IC) mounted in the data chip film package 132. Non-uniformity of temperature in the regions reduces color uniformity.

[0062] Heat generated from the point light elements 143 of the first and second point light source assemblies 145a, 145b is conducted to the sides 162 of the lower container 160 through the first and second support substrates 144a, 144b and transmitted outside. To decrease the temperature around the first point light source assembly 145a, more heat out of the first point light source assembly 145a can be dissipated to the outside as compared with the second point light source assembly 145b. In an exemplary embodiment, the area of the first support substrate 144a is larger than the second support substrate 144b. For example, the first and second support substrates 144a, 144b are formed into a long rectangular plate. In an exemplary embodiment, the sides of the first and second support substrates 144a, 144b can face the sides 162 of the lower container 160, and the width W1 of the first support substrate 144a can be larger than the width W2 of the second support substrate 144b. For example, when the width W1 of the first support substrate 144a is 1.2 times larger than the width W2 of the second support substrate 144b, the region around the first point light source assembly 145a can decrease the temperature by about 2° C. to about 5° C.

[0063] For the first point light source assembly 145a disposed at the relatively high-temperature region, color uniformity can be improved by increasing the area of the first support substrate 144a facing the side 162 of the lower container 160 while decreasing the surrounding temperature.

[0064] Since the first support substrate 144a is larger than the second support substrate 144b in area, the first groove 166a may be formed with a depth D1 which is larger than the second groove 166b with a depth D2. Therefore, the point light elements 143 of the first and second point light source assemblies 145a, 145b are regularly located at predetermined positions, facing the light guide plate 142.

[0065] FIG. 5a is an exploded perspective view showing a point light source assembly and a lower container accommodating the point light source assembly included in a liquid crystal display according to an exemplary embodiment of the present invention. FIG. 5b is a cross-sectional view of a point light source assembly and a lower container taken along the

line Vb-Vb' in FIG. 5a. FIG. 5c is a cross-sectional view of a point light source assembly and a lower container taken along the line Vc-Vc' in FIG. 5a.

[0066] Referring to FIGS. 5a to 5c, a first point light source assembly 245a includes a plurality of point light elements 143 and a first support substrate 244a having the point light elements 143. A first groove 266a to receive the first point light source assembly 245a and a second groove 166b to receive the second point light source assembly 145b are formed on the bottom of a lower container 260 along two sides 162.

[0067] Because the first point light source assembly 245a is disposed close to the data chip film package 132, the region around the first point light source assembly 245a is higher in temperature than the region around the second point light source assembly 145b due to heat generated by a driving IC mounted in the data chip film package 132. The central portion is higher in temperature than both sides in the first point light source assembly 245a.

[0068] To decrease the temperature of the first point light source assembly 245a at a level approximate to the second point light source assembly 145b, the area of the first support substrate 244a can be larger than the second support substrate 144b.

[0069] To decrease the temperature of the central portion at a level approximate to both side portions of the first point light source assembly 245a, the central area can be formed larger than the side portions of the first support substrate 244a. In an exemplary embodiment, the central width is larger than the side width of the first support substrate 244a. For example, the first support substrate 244a may be formed into a T-shape. When the central width is about 1.1 to about 1.2 times larger than the side width of the first support substrate 244a, the central portion can decrease the temperature by about 2° to about 5° C.

[0070] The side width of the first support substrate 244a may be set substantially the same as or larger than the width of the second support substrate 144b.

[0071] Color uniformity of the LCD 100 can be improved by forming the central width larger than the side width of the first support substrate 244a because the temperature of the central portion can be reduced.

[0072] Since the central width of the first support substrate is larger than the side width of the first support substrate 244a, the corresponding central portion of the first groove 266a can be formed deeper than the corresponding side portions of the first groove 266a.

[0073] FIG. 6a is an exploded perspective view showing a point light source assembly and a lower container accommodating the assembly included in a liquid crystal display according to an exemplary embodiment of the present invention. FIG. 6b is a cross-sectional view of a point light source assembly and lower container taken along the line VIb-VIb' of FIG. 6a.

[0074] Referring to FIGS. 6a and 6b, a first point light source assembly 345a includes a plurality of point light source elements 143 and a first support substrate 344a having the point light source elements 143. A first groove 366a to receive the first point light source assembly 345a and a second groove (not shown) to receive the second point light source assembly 145b are formed on the bottom of a lower container 360 along two sides 162.

[0075] Because the first point light source assembly 345a is disposed close to the data chip film package 132, the region

around the first point light source assembly **345a** is higher in temperature than the region around the second point light source assembly **145b** due to heat generated by a driving IC mounted in the data chip film package **132**. The central portion of the first point light source assembly **345a** is higher in temperature than short-side portions of the first point light source assembly **345a**.

[0076] To decrease the temperature of the first point light source assembly **345a** at a level approximate to the second point light source assembly **145b**, the area of the first support substrate **344a** can be larger than the second support substrate **144b**. To decrease the temperature of the central portion of the first light source assembly **345a** to a level approximate to both side portions of the first point light source assembly **345a**, the central portion can be formed larger than the side portions of the first support substrate **344a**. The central width of the first support substrate **344a** can be larger than the side width of the first support substrate **344a**. For example, the first support substrate **344a** may be formed into an arch with a wide central portion.

[0077] Color uniformity of the LCD **100** can be improved by increasing the central width of the first support substrate **344a** than the side width of the first support substrate **344a**.

[0078] Since the central width of the first support substrate **344a** is larger than the side width of the first support substrate **344a**, the first groove **366a** can be formed in an arch with the central portion deeper than the side portions to correspond to the shape of the first support substrate **344a**.

[0079] FIG. **7a** is an exploded perspective view of a point light source assembly and a lower container accommodating the assembly included in a liquid crystal display according to an exemplary embodiment of the present invention. FIG. **7b** is a cross-sectional view of a point light source assembly and a lower container taken along the line VIIb-VIIb' in FIG. **7a**.

[0080] Referring to FIGS. **7a** and **7b**, a first point light source assembly **445a** includes a plurality of point light source elements **143** and a first support substrate **444a** having the point light source elements **143** thereon. A first groove **466a** to receive the first point light source assembly **445a** and a second groove **166b** to receive the second point light source assembly **145b** are formed on the bottom of a lower container **460** along two sides **162**.

[0081] Because the first point light source assembly **445a** is disposed close to the data chip film package **132**, the region around the first point light source assembly **445a** is higher in temperature than the region around the second point light source assembly **145b** due to heat generated by a driving IC mounted in the data chip film package **132**.

[0082] Heat generated from the point light source elements **143** in the first point light source assembly **445a** is transmitted to the side **162** of the lower container **460** through the first support substrate **444a** and a first heat conductive pad **400a** interposed between the first support substrate **444a** and the side **162** of the lower container **460**. Heat generated from the point light source elements **143** in the second point light source assembly **145b** is transmitted to the side **162** of the lower container **460** through the second support substrate **144b** and a second heat conductive pad **400b** interposed between the second support substrate **144b** and side **162** of the lower container **460**. Respectively interposed between the first and second point light source assemblies **445a** and **145b** and the side **162** of the lower container **460**, the first and second heat conductive pads **400a**, **400b** dissipate heat generated from the first and second point light source assemblies

**445a** and **145b** to the outside. The first and second heat conductive pads **400a**, **400b** may be used to attach the first and second point light source assemblies **445a** and **145b** to the sides of the lower container **460**.

[0083] To decrease the temperature of the first point light source assembly **445a** at a level approximate to the second point light source assembly **145b**, the area of the first heat conductive pad **400a** can be larger than the second heat conductive pad **400b**. For example, when the first and second heat conductive pads **400a**, **400b** are formed into a long rectangular plate, the width of the first heat conductive pad **400a** can be larger than the width of the second heat conductive pad **400b**. For example, when the width of the first heat conductive pad **400a** is 1.2 times larger than the second heat conductive pad **400b** the first point light source assembly **445a** can decrease the temperature by about 2° C. to about 5° C.

[0084] Color uniformity of the LCD **100** can be improved by forming the width of the first heat conductive pad **400** larger than the second heat conductive pad **400b**.

[0085] In an exemplary embodiment, the first support substrate **444a** may have a larger area than the second support substrate **144b** to further decrease the temperature around the first point light source assembly **445a**.

[0086] In an exemplary embodiment of the present invention, uniformity in temperature is achieved throughout the liquid crystal display **100** by forming the area of the first heat conductive pad **400a** larger than the second heat conductive pad **400b**. In an exemplary embodiment of the present invention, uniformity of temperature is achieved by using a material having a higher heat conductivity for the first heat conductive pad **400a** as compared with the second heat conductive pad **400b**.

[0087] FIG. **8** is an exploded perspective view of the point light source assembly and a lower container accommodating the assembly according to an exemplary embodiment of the present invention.

[0088] Because the first point light source assembly **445a** is disposed close to the data chip film package **132**, the region around the first point light source assembly **445a** is higher in temperature than the region around the second point light source assembly **145b** due to heat generated by a driving IC mounted in the data chip film package **132**. The central portion is higher in temperature than short-side portions in the first point light source assembly **445a**.

[0089] Heat generated from the point light source elements **143** in the first point light source assembly **445a** is transmitted to the side **162** of the lower container **460** through the first support substrate **444a** and a first heat conductive pad **500a** interposed between the first support substrate **444a** and the side **162** of the lower container **460**. Interposed between the first point light source assembly **445a** and the side **162** of the lower container **460**, the first heat conductive pads **500a** dissipates heat generated from the first point light source assembly **445a** to the outside. The first heat conductive pad **500a** may be used to attach the first point light source assembly **445a** to the side of the lower container **460**.

[0090] To decrease the central temperature at a level approximate to the side portions in the first point light source assembly **445a**, the central area is formed larger than the side areas in the first heat conductive pad **500a**. In an exemplary embodiment, the first heat conductive pad **500a** has larger width at the central portion than the side portions. For example, the first heat conductive pad **500a** may have an

H-shape. For example, as shown in FIG. 9, a first heat conductive pad 500a' may have a T-shape.

[0091] For the central portion of the first point light source assembly 445a disposed at a relatively high-temperature region, color uniformity can be improved by increasing the central width than the sides in the first heat conductive pad 500a with decrease in temperature.

[0092] In an exemplary embodiment, the color uniformity using the first heat conductive pad 500a can be achieved by making the central portion corresponding to the central portion of the first support substrate 444a of a material having a higher heat conductivity as compared with the side portions corresponding to the side portions of the first support substrate 444a.

[0093] FIG. 10a is a perspective view of a point light source assembly included in a liquid crystal display according to an exemplary embodiment of the invention. FIG. 10b is a plan view of the point light source assembly according to an exemplary embodiment of the present invention. FIG. 11 is a diagram of a heat conductive pad in a point light source assembly according to an exemplary embodiment of the present invention.

[0094] Referring to FIGS. 10a and 10b, a point light source assembly 1400 includes point light source components 1410, a support substrate 1430, and a heat conductive pad 1450. Each point light source element 1410 includes a light emitting chip (not shown). The light emitting chip is a PN junction diode, in which when P- and N-type diodes are bonded and a voltage is applied to the diodes, and holes of the P-type semiconductor are concentrated on the intermediate layer of the N-type semiconductor. The electrons of the N-type semiconductor are concentrated on the intermediate layer that is the lowest part of a conduction band of the P-type semiconductor. The electrons drop on the holes of a valence band. When the electrons drop, energy corresponding to the difference in potential levels of the conduction band and valence band, i.e. an energy gap, is released into light. Alternatively, light emitting chip that emits light in a variety of ways may be used. The light emitting chip can emit light with a variety of wavelengths. To emit light with a variety of wavelengths, for example, it is possible to adjust content of indium that is used as an active layer in nitride-based light emitting diodes, to combine light emitting diodes that emit light having different wavelengths, or to combine a fluorescent body with a light emitting chip that emits light in a predetermined range of wavelength, such as, for example, ultraviolet rays.

[0095] In an exemplary embodiment, the point light source elements 1410 are side view-typed light emitting diodes that emit light through the sides.

[0096] The support substrate 1430 is formed with a circuit pattern to mount the point light source elements 1410. For example, the support substrate 1430 may be any one of various printed circuit boards, such as, for example, a Flexible PCB (FPCB), a common printed circuit board (e.g., a rigid PCB), or a metal PCB.

[0097] The support substrate 1430 having the point light source elements 1410 is disposed on the heat conductive pad 1450. The heat conductive pad 1450 is interposed between the support substrate 1430 and the bottom of a lower container (not shown) and dissipates heat generated from the point light source elements 1410 to the bottom of the lower container. The heat conductive pad 1450 may comprise a material having a good heat conductivity, such as, for example, metallic materials.

[0098] The entire region of the heat conductive pad 1450 is sectioned into several unit regions where groups of the point light source elements (G1 to G5) are disposed. That is, the heat conductive pad 1450 is sectioned into a unit region A for a first point light source element group G1, a unit region B for a second point light source element group G2, a unit region C for a third point light source element group G3, a unit region D for a fourth point light source element group G4, and a unit region E for a fifth point light source element group G5. Each point light source element group includes four point light source elements. That is, the first point light source element group G1 includes a first point light source element 14101a to a fourth point light source element 14101d and the other groups of point light source element have substantially the same configuration. In an exemplary embodiment of the present invention, four point light source elements are arranged in a line in each group of point light source element.

[0099] The heat conductive pad 1450 includes the central portion I with dense point light source elements and edge portions II at both sides of the central portion I. The central portion includes the unit regions B, C and D while the left and right edge portions II includes the unit regions A and E, respectively. In the heat conductive pad 1450, the unit region pertaining to the edge portions II, i.e. the unit regions A or E is formed smaller in area than any one of the unit regions pertaining to the central portion I, i.e. the unit regions B, C and D. In an exemplary embodiment, the unit regions A and E of the edge portions II are formed into a trapezoid with the height Ly and the base LA and LE, respectively. In an exemplary embodiment, the unit region B in the central portion I can be formed into a square or a rectangular shape with the base LB and the height LY, where LA=LB=LE.

[0100] When the unit regions in the central portion I are larger in area than the unit regions in the edge portions II, the unit regions with dense point light source elements 1410 is improved in dissipation efficiency, so that the heat conductive pad 1450 can be controlled to dissipate heat uniformly throughout the whole regions.

[0101] The heat conductive pad 1450 shown in FIG. 11 is sectioned into a unit region A to a unit region E and formed into a substantially half octagon.

[0102] The upper side of the heat conductive pad 1450, i.e. the shorter side is about 100 mm in length (L2). The base opposite to the upper side, i.e. the longer side is about 265 mm in length (L1). The first height H1 is about 15 mm, and the second height H2 is about 30 mm. The dimension of the heat conductive pad 1450 is a heat conductive pad according to an exemplary embodiment of the present invention and may be variously changed. For example, a ratio among each side can be when the shorter side of the heat conductive pad 1450 is 1 in length, the longer side may be 2.6 to 2.8, the first height can be 0.1 to 0.2, and the second height can be 0.29 to 0.31.

[0103] FIG. 12a is an exploded perspective view of a backlight unit having a point light source assembly according to an exemplary embodiment of the present invention. FIG. 12b is an exploded perspective view of a backlight unit according to an exemplary embodiment of the present invention.

[0104] Referring to FIGS. 12a and 12a, a backlight unit includes the light guide plate 142, a point light source assembly 1400 that provides light to the light guide plate 142, optical sheets 141 disposed on the upper surface of the light guide plate 142, and a reflective sheet 146 disposed under the light guide plate 142.

[0105] The point light source assembly **1400** includes point light source elements **1410** mounted on the support substrate **1430** and a heat conductive pad **1450** in which the unit regions pertaining to the central portion are smaller in area than those pertaining to the edge portions. The point light source assembly **1400** is disposed at a side (see e.g., FIG. **12a**) or both sides (see e.g., FIG. **12b**) of the light guide plate **142** and used to provide light to the light guide plate **142**. The light guide plate **142** converts light with optical distribution of a point light source type that is generated from the point light source assembly **1400** into light with optical distribution of a surface light source type.

[0106] FIG. **13** shows a table for comparing heat dissipation of a point light source assembly of a related art and a point light source assembly of an exemplary embodiment of the present invention. In FIG. **13**, a point light source assembly that has a heat conductive pad in which the unit regions in the central portion is the same as the unit regions in the edge portion in area is selected for the related art, and a point light source assembly in which the unit regions in the central portion are larger in area than the unit regions in the edge portions as described above is selected for an exemplary embodiment of the present invention.

[0107] According to the related art, the point light source elements at the left edge were  $44.4^{\circ}\text{C}$ . in temperature, the point light source elements at the right edge were  $42.2^{\circ}\text{C}$ ., and the point light source elements at the central portion were  $47.4^{\circ}\text{C}$ . Accordingly, it can be seen from the table that the point light source elements at the central portion is about  $3$  to about  $4^{\circ}\text{C}$ . higher than the edge portions. The differences in temperature are related to the differences in luminance of the point light source elements.

[0108] According to an exemplary embodiment of the present invention, the point light source elements at the left edge portion were  $45.1^{\circ}\text{C}$ . in temperature, the point light source elements at the right edge were  $45.9^{\circ}\text{C}$ ., and the point light source elements at the central portion were  $45.4^{\circ}\text{C}$ . Accordingly, it can be seen from the table that differences in temperature are not substantial in the point light source elements in an exemplary embodiment of the present invention. As a result, luminance of the whole point light source elements on the heat conductive pad is almost uniformly distributed.

[0109] FIG. **14a** is a perspective view of a point light source assembly included in a liquid crystal display according to an exemplary embodiment of the invention, and FIG. **14b** is a plan view of a point light source assembly according to an exemplary embodiment of the present invention.

[0110] The point light source assembly **1400** includes point light source elements **1410**, a support substrate **1430**, and a heat conductive pad **1460**.

[0111] The entire region of the heat conductive pad **1460** is sectioned into several unit regions where groups of point light source element (**G1** to **G5**) are disposed. That is, the heat conductive pad **1460** is sectioned into a unit region **F** for a first point light source element group **G1**, a unit region **G** for a second point light source element group **G2**, a unit region **H** for a third point light source element group **G3**, a unit region **I** for a fourth point light source element group **G4**, and a unit region **J** for a fifth point light source element group **G5**. Each point light source element group includes four point light source elements. That is, the first point light source element group **G1** includes a first point light source element **14101a** to a fourth point light source element **14101d**, and the other

groups of point light source element have substantially the same configuration. In an exemplary embodiment of the present invention, four point light source elements are arranged in a line in each group of point light source element.

[0112] The heat conductive pad **1460** is divided into the central portion **I** with dense point light source elements and edge portions **II** at both sides of the central portion **I**. The central portion includes the unit regions **G**, **H** and **I** while the left and right edge portions **II** include the unit regions **F** and **J**, respectively. In the heat conductive pad **1460**, the unit region pertaining to the edge portions **II**, i.e. the unit regions **F** or **J** is formed smaller in area than any one of the unit regions pertaining to the central portion **I**, i.e. the unit regions **G** and **I**. In an exemplary embodiment of the present invention, the unit regions **F** and **J** of the edge portions **II** are formed into a square or a rectangular shape with the height **Ly2** and the base **LF** and **LJ**. The unit region **G** in the central portion **I** can be formed into a trapezoid with the base **LG** and the height **LY1**, where  $LF=LJ=LG$  and  $Ly2<LY1$ . However, the shapes of the unit regions are not limited to the above and may be variously modified.

[0113] According to an exemplary embodiment of the present invention, by increasing a heat dissipating rate for point light source assemblies at relatively high-temperature regions, color uniformity can be improved throughout a display.

[0114] Although the illustrative embodiments of the present invention have been described herein with reference to the accompanying drawings, it is to be understood that the present invention should not be limited to those precise embodiments and that various other changes and modifications may be affected herein by one of ordinary skill in the related art without departing from the scope or spirit of the invention. All such changes and modifications are intended to be included with the scope of the invention as defined by the appended claims.

What is claimed is:

1. A liquid crystal display comprising:

a light guide plate guiding incident light;

a first point light source assembly including first point light source elements providing the light to the light guide plate and a first support substrate having the first point light source elements, the first point light source assembly being disposed at a first side of the light guide plate;

a second point light source assembly including second point light source elements providing the light to the light guide plate and a second support substrate having the second point light source elements, the second point light source assembly being disposed at a second side of the light guide plate;

a liquid crystal panel assembly disposed on the light guide plate and displaying image information;

a lower container accommodating the light guide plate, first and second point light source assemblies, and liquid crystal panel assembly; and

first and second heat conductive pads interposed between the lower container and the first and second point light source assemblies, respectively,

wherein the first heat conductive pad is larger in area than the second heat conductive pad.

2. The liquid crystal display of claim 1, wherein the first heat conductive pad is larger in width than the second heat conductive pad.

3. The liquid crystal display of claim 1, wherein the first heat conductive pad is larger in width at a central portion than at edge portions.

4. The liquid crystal display of claim 1, wherein the central portion comprises a material having a heat conductivity higher than a heat conductivity of the edge portions in the first heat conductive pad.

5. The liquid crystal display of claim 1, wherein the lower container comprises a bottom, sides formed at edges of the bottom, and first and second grooves formed on the bottom along the sides to receive the first and second point light source assemblies, respectively.

6. The liquid crystal display of claim 1, wherein:  
the liquid crystal panel assembly comprises a liquid crystal panel and a chip film package connected to a side of the liquid crystal panel and providing driving signals to the liquid crystal panel; and  
the first point light source assembly is disposed adjacent to the chip film package.

7. The liquid crystal display of claim 6, wherein the chip film package is connected with data lines of the liquid crystal panel and provides data driving signals to the liquid crystal panel.

8. A liquid crystal display comprising:  
a light guide plate guiding incident light;  
a point light source assembly including point light source elements providing the light to the light guide plate and

a support substrate having groups of point light source elements comprising at least one of the point light source elements;

a lower container accommodating the light guide plate and point light source assembly; and

a heat conductive pad interposed between the point light source assembly and the lower container,

wherein the heat conductive pad includes unit regions having the groups of point light source elements, and the unit regions include a first unit region and a second unit region, wherein the first unit region and the second unit region are different in size.

9. The liquid crystal display of claim 8, wherein:  
the heat conductive pad includes a central portion including the first unit region and edge portions disposed at sides of the central portion including second unit region; and

the first unit region is larger in area than the second unit region.

10. The liquid crystal display of claim 9, wherein:  
the first unit region is formed to have a square or a rectangle shape; and

the second unit region is formed to have a trapezoid shape

11. The liquid crystal display of claim 9, wherein the first and second unit regions are formed to have a square or a rectangle shape.

\* \* \* \* \*

专利名称(译)	液晶显示器		
公开(公告)号	<a href="#">US20120081633A1</a>	公开(公告)日	2012-04-05
申请号	US13/232113	申请日	2011-09-14
[标]申请(专利权)人(译)	CHUN HYO SUCK 朴镇宇 李光HEE KWAK YONG SEOK		
申请(专利权)人(译)	俊孝SUCK 朴镇宇 李光-HEE KWAK永硕		
当前申请(专利权)人(译)	三星DISPLAY CO. , LTD.		
[标]发明人	CHUN HYO SUCK PARK JIN WOO LEE KWANG HEE KWAK YONG SEOK		
发明人	CHUN, HYO-SUCK PARK, JIN-WOO LEE, KWANG-HEE KWAK, YONG-SEOK		
IPC分类号	G02F1/1335		
CPC分类号	G02B6/0055 G02B6/0068 G02B6/0073 G02F1/133382 G02F1/133609 G02F1/133615 G02B6/0088		
优先权	1020060115165 2006-11-21 KR 1020060123917 2006-12-07 KR		
外部链接	<a href="#">Espacenet</a> <a href="#">USPTO</a>		

摘要(译)

液晶显示器包括引导入射光的导光板，第一点光源组件，包括向光导板提供光的第一点光源元件和具有第一点光源元件的第一支撑基板，第一点光源组件点光源组件设置在导光板的一侧，第二点光源组件包括向导光板提供光的第二点光源元件和具有第二点光源元件的第二支撑基板，第二点光源组件设置在导光板的另一侧，液晶面板组件设置在导光板上，显示图像信息，下容器容纳导光板，第一和第二点光源组件和液晶面板组件。

