



US009606395B2

(12) **United States Patent**
Kawamura

(10) **Patent No.:** **US 9,606,395 B2**
(45) **Date of Patent:** **Mar. 28, 2017**

(54) **SET OF POLARIZING PLATES AND FRONT-PLATE-INTEGRATED LIQUID CRYSTAL DISPLAY PANEL**

(56) **References Cited**

U.S. PATENT DOCUMENTS

(71) Applicant: **Sumitomo Chemical Company, Limited, Tokyo (JP)**

7,063,872 B1 6/2006 Amimori et al.
8,525,405 B2 9/2013 Kuwabara et al.
(Continued)

(72) Inventor: **Takahito Kawamura, Niihama (JP)**

FOREIGN PATENT DOCUMENTS

(73) Assignee: **SUMITOMO CHEMICAL COMPANY, LIMITED, Tokyo (JP)**

JP H02-27121 U 2/1990
JP 2000009908 A 1/2000

(*) Notice: Subject to any disclaimer, the term of this patent is extended or adjusted under 35 U.S.C. 154(b) by 0 days.

(Continued)

OTHER PUBLICATIONS

(21) Appl. No.: **15/026,659**

Decision to Grant issued Apr. 5, 2016 in JP Application No. 2013-208480.

(22) PCT Filed: **Sep. 29, 2014**

(Continued)

(86) PCT No.: **PCT/JP2014/075818**

§ 371 (c)(1),
(2) Date: **Apr. 1, 2016**

Primary Examiner — Paisley L Arendt
(74) *Attorney, Agent, or Firm* — Panitch Schwarze Belisario & Nadel LLP

(87) PCT Pub. No.: **WO2015/050075**

PCT Pub. Date: **Apr. 9, 2015**

(57) **ABSTRACT**

(65) **Prior Publication Data**

US 2016/0252774 A1 Sep. 1, 2016

Provided is a set of polarizing plates comprising a front-plate-integrated polarizing plate to be disposed at a viewing side of a liquid crystal cell and a back-side polarizing plate to be disposed at a back side of the cell. The front-plate-integrated polarizing plate includes a front-side polarizing plate and a front plate having a Young's modulus of 2 GPa or more. The set of polarizing plates satisfies the formula: $(R_a - F_t) < (F_a - R_t)$, where F_a and F_t represent ratios of dimensional change observed in the front-side polarizing plate in absorption and transmission axis directions, respectively, after the front-side polarizing plate is heated at 85° C. for 100 hours, and R_a and R_t represent ratios of dimensional change observed in the back-side polarizing plate in absorption and transmission axis directions, respectively, after the back-side polarizing plate is heated at 85° C. for 100 hours.

(30) **Foreign Application Priority Data**

Oct. 3, 2013 (JP) 2013-208480

(51) **Int. Cl.**
G02F 1/1335 (2006.01)
G02B 5/30 (2006.01)

(52) **U.S. Cl.**
CPC **G02F 1/133528** (2013.01); **G02B 5/3025** (2013.01); **G02F 2001/133562** (2013.01); **G02F 2001/133567** (2013.01)

(58) **Field of Classification Search**
CPC ... G02F 1/133528; G02F 2001/133562; G02F 2001/133567; G02B 5/3025

See application file for complete search history.

8 Claims, 2 Drawing Sheets

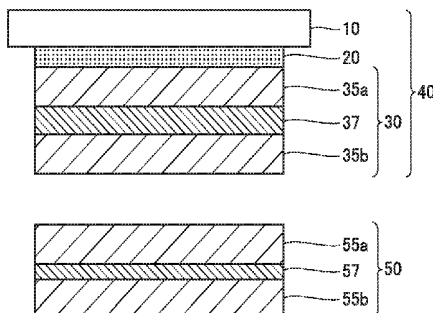

(56)

References Cited

U.S. PATENT DOCUMENTS

2006/0268200 A1* 11/2006 Ohgaru C09K 19/2007
349/97
2010/0157205 A1 6/2010 Kiya et al.
2012/0026433 A1* 2/2012 Lee G02B 27/26
349/96
2013/0004700 A1 1/2013 Jo et al.
2013/0169911 A1 7/2013 Haida et al.
2014/0125925 A1 5/2014 Sawada et al.

FOREIGN PATENT DOCUMENTS

JP 2001033775 A 2/2001
JP 2002127286 A 5/2002
JP 2002221715 A 8/2002
JP 2002236213 A 8/2002
JP 2006126585 A 5/2006
JP 2006330390 A 12/2006
JP 2007144926 A 6/2007
JP 2009103818 A 5/2009
JP 2009265215 A 11/2009
JP 2011248363 A 12/2011
JP 2012058429 A 3/2012

JP 2012128384 A 7/2012
JP 2012159778 A 8/2012
JP 2013015811 A 1/2013
JP 2013037104 A 2/2013
JP 2013037115 A 2/2013
JP 2013152465 A 8/2013
KR 20080040003 A 5/2008
KR 20120012600 A 2/2012
WO 0046617 A1 8/2000
WO 2007122941 A1 11/2007
WO 2014163212 A1 10/2014

OTHER PUBLICATIONS

Allowed Claims issued Apr. 5, 2016 in JP Application No. 2013-208480.
Office Action issued Nov. 17, 2015 in JP Application No. 2013208480.
International Search Report issued Dec. 22, 2014 in International Application No. PCT/JP2014/075818.
Notice of Provision of Information by Third Party issued Mar. 15, 2016 in JP Application No. 2013-208480.
Office Action mailed Oct. 21, 2016 in KR 10-2016-7010501.

* cited by examiner

FIG.1

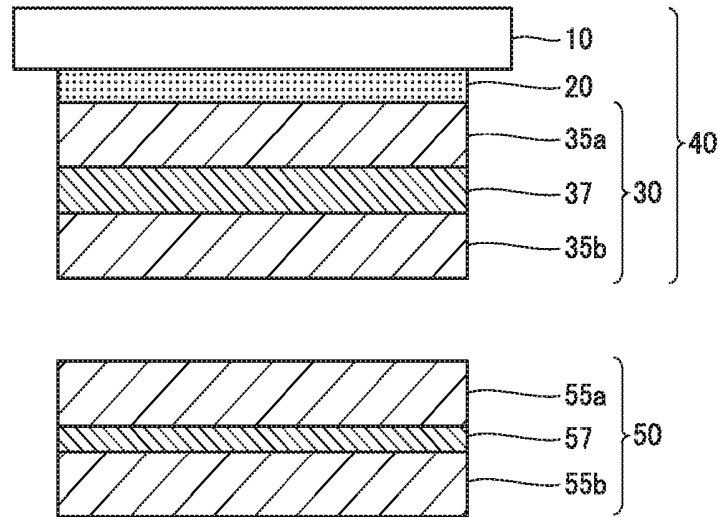

FIG.2

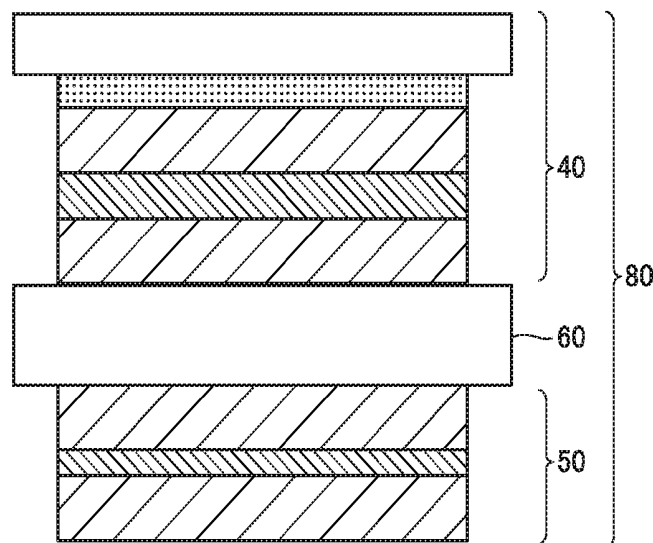

FIG.3

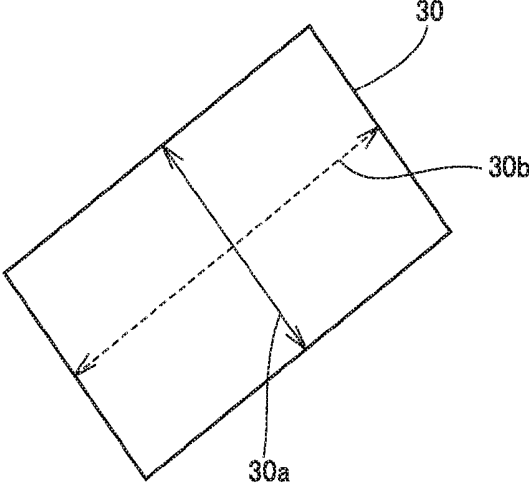
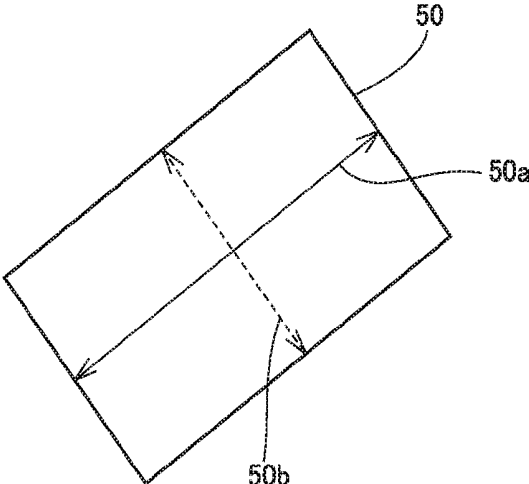

FIG.4



SET OF POLARIZING PLATES AND FRONT-PLATE-INTEGRATED LIQUID CRYSTAL DISPLAY PANEL

CROSS-REFERENCE TO RELATED APPLICATION

This application is a Section 371 of International Application No. PCT/JP2014/075818, filed Sep. 29, 2014, which was published in the Japanese language on Apr. 9, 2015, under International Publication No. WO 2015/050075 A1, and the disclosure of which is incorporated herein by reference.

TECHNICAL FIELD

The present invention relates to a set of polarizing plates including a front-side polarizing plate having a front-plate integrated therewith and a back-side polarizing plate, and a front-plate-integrated liquid crystal display panel in which these polarizing plates are stuck on a liquid crystal cell.

BACKGROUND ART

Liquid crystal display devices have conventionally been used for desk calculators, electronic clocks, personal computers, etc. and in recent years there is an increasing demand therefor, and recently they are also applied to a wide range of applications such as mobile phones, tablet type terminals and the like. These liquid crystal display devices normally include as a main member a liquid crystal display panel including a liquid crystal cell with a pair of polarizing plates that are disposed on front and back sides of the liquid crystal cell.

In the recent market, as mobile devices such as mobile phones and tablet type terminals having a screen increased in size are widely used, there is a demand for reduction in weight and thickness of a constituent member thereof, namely a liquid crystal display panel, and there is a tendency to reduce a liquid crystal cell's glass substrate, a front plate and/or the like in thickness. Furthermore, in order to eliminate reflection and scattering of light at an interface to enhance visibility, there is also a tendency to integrate the front plate with the liquid crystal display panel using a pressure sensitive adhesive, an ultraviolet curing type resin or the like.

Conventional liquid crystal display panels have a thick front plate and a thick liquid crystal cell, and their warping resulting from a polarizing plate's shrinkage has thus been suppressed even in high temperature environments. The above-mentioned recent tendency to reduce in thickness the front plate, the glass substrate used for a liquid crystal cell and the like, however, results in the warping of the liquid crystal display panel, which is attributed to the polarizing plates shrinkage in high temperature environments, and as a consequence, for example, a problem has arisen that the liquid crystal display panel cannot be accommodated in a casing for a final product.

In order to suppress such warping of the liquid crystal display panel, a conventionally known methodology provides a polarizing plate (a front-side polarizing plate) to be disposed at a viewing side of a liquid crystal cell and a polarizing plate (a back-side polarizing plate) to be disposed at a side opposite to the viewing side of the liquid crystal cell (a back-side) such that the polarizing plates are different in thickness. For example, Japanese Patent Laying-Open No. 2012-058429 (PTD 1) describes a method for suppressing a

liquid crystal display panel's warping by reducing a front-side polarizing plate's polarizing film (polarizer) to be smaller in thickness than a back-side polarizing plate's polarizing film.

However, a liquid crystal display panel's warping in a high temperature environment is attributed to a polarizing plate's shrinkage that depends upon a polarizer's thickness, as has been set forth above, and when the polarizer of the front-side polarizing plate is reduced in thickness, as described in PTD 1, a liquid crystal display panel having a front plate integrated using a pressure sensitive adhesive or an ultraviolet curing type resin for improved visibility, in particular, may have the warping, and suppression of the warping is thus not necessarily satisfactory.

Furthermore, Japanese Patent Laying-Open No. 2002-221715 (PTD 2) describes that in a liquid crystal display element (a liquid crystal display panel) using a plastic-substrate-containing liquid crystal cell, a protective layer that constitutes a front-side polarizing plate is smaller in thickness than a protective layer that constitutes a back-side polarizing plate to suppress the amount of warping of the plastic-substrate-containing liquid crystal cell. When the method making protective layers different in thickness, as described in PTD 2, is applied to a liquid crystal display panel having a front-side polarizing plate with a front plate integrated therewith for improved visibility, however, a liquid crystal cell of the panel may have the warping resulting from the protective layer's thermal shrinkage and the problem may arise that the panel cannot be accommodated in a casing for a final product.

CITATION LIST

Patent Document

PTD 1: Japanese Patent Laying-Open No. 2012-058429
PTD 2: Japanese Patent Laying-Open No. 2002-221715

SUMMARY OF INVENTION

Technical Problem

An object of the present invention is to provide a set of polarizing plates that can suppress an amount of warping in a high temperature environment when applied in a liquid crystal display panel, and a front-plate-integrated liquid crystal display panel in which the set of polarizing plates are stuck on a liquid crystal cell.

Solution to Problem

The present invention provides a set of polarizing plates and a front-plate-integrated liquid crystal display panel, as below:

[1] A set of polarizing plates comprising a front-plate-integrated polarizing plate to be disposed at a viewing side of a liquid crystal cell, and a back-side polarizing plate to be disposed at a back side of the liquid crystal cell, the front-plate-integrated polarizing plate including a front-side polarizing plate and a front plate, the front plate being disposed at a viewing side of the front-side polarizing plate and having a Young's modulus equal to or greater than 2 GPa,

the set of polarizing plates satisfying the following formula:

$$(R_{\alpha-F}) < (F_{\alpha-R})$$

[1],

where F_a represents a ratio of dimensional change observed in the front-side polarizing plate in an absorption axis direction after the front-side polarizing plate is heated at 85° C. for 100 hours and F_t represents a ratio of dimensional change observed in the front-side polarizing plate in a transmission axis direction after the front-side polarizing plate is heated at 85° C. for 100 hours, and R_a represents a ratio of dimensional change observed in the back-side polarizing plate in an absorption axis direction after the back-side polarizing plate is heated at 85° C. for 100 hours and R_t represents a ratio of dimensional change observed in the back-side polarizing plate in a transmission axis direction after the back-side polarizing plate is heated at 85° C. for 100 hours.

[2] The set of the polarizing plates according to item [1], wherein:

the front-side polarizing plate and the back-side polarizing plate each include a polarizer; and

the polarizer of the front-side polarizing plate is larger in thickness than the polarizer of the back-side polarizing plate.

[3] The set of polarizing plates described at item [1] or [2], wherein:

the front-side polarizing plate and the back-side polarizing plate have a rectangular shape having a longer side and a shorter side;

the front-side polarizing plate has an absorption axis approximately parallel to a direction of the shorter side; and the back-side polarizing plate has an absorption axis approximately parallel to a direction of the longer side.

[4] The set of polarizing plates described at any one of items [1] to [3], wherein the front-side polarizing plate and the back-side polarizing plate each include:

a polarizer composed of a polyvinyl alcohol-based resin film; and

a protective layer laminated on at least one surface of the polarizer.

[5] The set of polarizing plates described at item [4], wherein:

at least one of the front-side polarizing plate and the back-side polarizing plate includes a liquid-crystal-cell-side protective layer laminated on a surface of the polarizer closer to the liquid crystal cell; and

the liquid-crystal-cell-side protective layer has an in-plane phase retardation.

[6] The set of polarizing plates described at item [4] or [5], wherein the back-side polarizing plate further includes another optical layer other than the polarizer and the protective layer laminated on an outermost surface opposite to the liquid crystal cell.

[7] A front-plate-integrated liquid crystal display panel comprising the set of polarizing plates described at any one of items [1] to [6], and a liquid crystal cell, wherein: the front-plate-integrated polarizing plate is stuck, at its front-side polarizing plate's side, on a viewing side of the liquid crystal cell; and the back-side polarizing plate is stuck on a back side of the liquid crystal cell.

[8] The front-plate-integrated liquid crystal display panel described at item [7], having a warping amount in absolute value of 0.5 mm or less when heated at 85° C. for 240 hours.

Advantageous Effect of Invention

The present invention can provide a front-plate-integrated liquid crystal display panel that can effectively suppress an

amount of warping in a high temperature environment and can be easily accommodated in a casing for a final product.

BRIEF DESCRIPTION OF DRAWINGS

FIG. 1 is a cross-sectional view schematically showing an example of a preferable layer configuration in a set of polarizing plates according to the present invention.

FIG. 2 is a cross-sectional view schematically showing an example of a preferable layer configuration in a front-plate-integrated liquid crystal display panel according to the present invention.

FIG. 3 is a schematic plan view showing a front-side polarizing plate and the axial angle of the absorption axis and transmission axis of the front-side polarizing plate.

FIG. 4 is a schematic plan view showing a back-side polarizing plate and the axial angle of the absorption axis and transmission axis of the back-side polarizing plate.

DESCRIPTION OF EMBODIMENTS

Set of Polarizing Plates

FIG. 1 is a cross-sectional view schematically showing an example of a preferable layer configuration in a set of polarizing plates according to the present invention. Furthermore, FIG. 2 shows a front-plate-integrated liquid crystal display panel 80 formed by sticking the polarizing plate set as shown in FIG. 1 (a front-plate-integrated polarizing plate 40 and a back-side polarizing plate 50) on a liquid crystal cell 60. With reference to FIG. 1, the set of polarizing plates of the present invention includes front-plate-integrated polarizing plate 40 and back-side polarizing plate 50. Front-plate-integrated polarizing plate 40 configuring the set of polarizing plates of the present invention is an integrated article of a front-side polarizing plate 30 and a front plate 10 disposed at a viewing side of front-side polarizing plate 30. In the example of FIG. 1, front-side polarizing plate 30 includes a polarizer 37; a protective layer 35a stuck on a viewing-side-surface of polarizer 37; and a protective layer 35b stuck on a surface of polarizer 37 opposite to the viewing side of polarizer 37 (a surface thereof closer to the liquid crystal cell).

Back-side polarizing plate 50 includes a polarizer 57; a protective layer 55a stuck on a viewing-side-surface of polarizer 57 (a surface thereof closer to liquid crystal cell 60); and a protective layer 55b stuck on a surface of polarizer 57 opposite to the viewing side of polarizer 57 (a surface thereof closer to a back side).

(1) Front Plate

Front plate 10 is responsible for suppressing warping of liquid crystal cell 60, protecting liquid crystal cell 60, and/or the like and can be a transparent (preferably, optically transparent) plate having a Young's modulus of equal to or greater than 2 GPa. As long as the above Young's modulus is satisfied, front plate 10 may have a mono-layer structure or a multi-layer structure.

Front plate 10 is disposed at an outermost surface in a final product using the front-plate-integrated liquid crystal display panel, and accordingly, it is required to present sufficient durability even when the panel is used outdoors or semi-outdoors. From such a viewpoint, front plate 10 is composed preferably of an inorganic material such as glass or tempered glass, or an organic material such as polycarbonate-based resin and acrylic resin.

Front plate 10 may be tempered glass, film or the like configuring a touchscreen panel for example. The touch-

screen panel is not limited in system, and an electrostatic capacitance system, a surface acoustic wave system, a resistive film system, an electromagnetic induction system, an optical sensor system, an infrared system, etc. are indicated as examples.

Front plate 10 may have functions such as antireflection, antifouling, electromagnetic wave shielding, near-infrared shielding, color adjustment, prevention of scattering of glass, and the like. For example, the front plate having the above function(s) can be a laminate of a substrate formed of the above-indicated inorganic or organic materials and one or more layers (or films) laminated on the substrate and having the above function(s). Front plate 10 of such a multi-layered structure can be fabricated for example by applying directly on the substrate formed of the above-indicated inorganic or organic materials an agent that is effective to provide the above function(s) or by sticking on the substrate a functional film separately produced and having the above function(s).

As shown in FIG. 1, front plate 10 and front-side polarizing plate 30 can be integrated together by sticking them together with an ultraviolet curing type resin or pressure sensitive adhesive 20 therebetween. In order to eliminate reflection and scattering of light at an interface of front plate 10 and front-side polarizing plate 30 to improve visibility, ultraviolet curing type resin or pressure sensitive adhesive 20 preferably has an index of refraction close or equal to an index of refraction of front plate 10 and is preferably optically transparent.

The ultraviolet curing type resin can be a general ultraviolet curable liquid material such as (metha)acrylic ester and epoxy resin. The pressure sensitive adhesive can be that with an acrylic polymer, a silicone-based polymer, polyester, polyurethane, polyether, etc. as a base polymer. Inter alia it is preferable to use an acrylic pressure sensitive adhesive excellent in optical transparency and having high transparency, such as an acrylic pressure sensitive adhesive. Herein, "(metha)acrylic ester" means acrylic ester and/or methacrylic ester, and "(metha)" in (metha)acrylate or the like is also the same in meaning.

(2) Front-Side Polarizing Plate and Back-Side Polarizing Plate

Front-side polarizing plate 30 is a polarizing plate to be disposed at the viewing side of liquid crystal cell 60 as front-plate-integrated polarizing plate 40 integrated with front plate 10 and at least includes polarizer 37. Front-side polarizing plate 30 normally includes in addition to polarizer 37 a protective layer laminated on at least one surface of polarizer 37. In the example of FIG. 1, protective layers 35a and 35b are stuck on the opposite surfaces of polarizer 37. The example of FIG. 1 is not exclusive, and for example protective layer 35b may be dispensed with and the protective layer may thus be laminated only on one surface of polarizer 37.

Back-side polarizing plate 50 is a polarizing plate to be disposed at a back side of liquid crystal cell 60 (i.e., a side opposite to the viewing side) and at least includes polarizer 57. Back-side polarizing plate 50 normally includes in addition to polarizer 57 a protective layer laminated on at least one surface of polarizer 57. In the example of FIG. 1, protective layers 55a and 55b are stuck on the opposite surfaces of polarizer 57. The example of FIG. 1, is not exclusive, and for example protective layer 55a may be dispensed with and the protective layer may thus be laminated only on one surface of polarizer 57.

FIG. 3 is a schematic plan view showing a front-side polarizing plate 30 and the axial angle of absorption axis 30a

and transmission axis 30b of front-side polarizing plate 30. FIG. 4 is a schematic plan view showing back-side polarizing plate 50 and the axial angle of absorption axis 50a and transmission axis 50b of back-side polarizing plate 50. As shown in the figures, front-side polarizing plate 30 and back-side polarizing plate 50 can have an external shape for example of a rectangle having a longer side and a shorter side. In that case, absorption axis 30a of front-side polarizing plate 30 (polarizer 37) and the shorter side of front-side polarizing plate 30 (and hence a shorter side of liquid crystal cell 60 on which front-side polarizing plate 30 is stuck) form an angle normally within ± 45 degrees, preferably within ± 10 degrees. More preferably, absorption axis 30a of front-side polarizing plate 30 and the shorter side of front-side polarizing plate 30 are parallel or are approximately parallel (that is, these form an angle within ± 7 degrees). Similarly, transmission axis 30b orthogonal to absorption axis 30a and the longer side of front-side polarizing plate 30 (and hence a longer side of liquid crystal cell 60 on which front-side polarizing plate 30 is stuck) form an angle normally within ± 45 degrees preferably within ± 10 degrees. More preferably, transmission axis 30b of front-side polarizing plate 30 and the longer side of front-side polarizing plate 30 are parallel or are approximately parallel (that is, these form an angle within ± 7 degrees). In FIG. 3, absorption axis 30a of front-side polarizing plate 30 and the shorter side of front-side polarizing plate 30 are parallel, and transmission axis 30b of front-side polarizing plate 30 and the longer side of front-side polarizing plate 30 are parallel.

Furthermore, with reference to FIG. 4, absorption axis 50a of back-side polarizing plate 50 (polarizer 57) and the longer side of back-side polarizing plate 50 (and hence a longer side of liquid crystal cell 60 on which back-side polarizing plate 50 is stuck) form an angle normally within ± 45 degrees, preferably within ± 10 degrees. More preferably, absorption axis 50a of back-side polarizing plate 50 and the longer side of back-side polarizing plate 50 are parallel or are approximately parallel (that is, these form an angle within ± 7 degrees). Similarly, transmission axis 50b orthogonal to absorption axis 50a and the shorter side of back-side polarizing plate 50 (and hence a shorter side of liquid crystal cell 60 on which back-side polarizing plate 50 is stuck) form an angle normally within ± 45 degrees, preferably within ± 10 degrees. More preferably, transmission axis 50b of back-side polarizing plate 50 and the shorter side of back-side polarizing plate 50 are parallel or are approximately parallel (that is, these form an angle within ± 7 degrees). In FIG. 4, absorption axis 50a of back-side polarizing plate 50 and the longer side of back-side polarizing plate 50 are parallel, and transmission axis 50b of back-side polarizing plate 50 and the shorter side of back-side polarizing plate 50 are parallel.

In the set of polarizing plates of the present invention having the above axial angle, F_a , F_r , R_a , and R_t satisfy the following relationship:

$$(R_a - F_r) < (F_a - R_t) \quad [1],$$

where F_a represents a ratio of dimensional change observed in the front-side polarizing plate 30 (neither having front plate 10 stuck thereon nor stuck on liquid crystal cell 60) in an absorption axis 30a direction after front-side polarizing plate 30 is heated at 85° C. for 100 hours and F_r represents a ratio of dimensional change observed in front-side polarizing plate 30 (neither having front plate 10 stuck thereon nor stuck on liquid crystal cell 60) in a transmission axis 30b direction after the front-side polarizing plate 30 is heated at 85° C. for 100 hours, and R_a represents a ratio of dimen-

sional change observed in the back-side polarizing plate **50** (without being stuck on liquid crystal cell **60**) in an absorption axis **50a** direction after the back-side polarizing plate **50** is heated at 85° C. for 100 hours and R_t represents a ratio of dimensional change observed in the back-side polarizing plate **50** (without being stuck on liquid crystal cell **60**) in a transmission axis **50b** direction after the back-side polarizing plate **50** is heated at 85° C. for 100 hours.

The ratio of dimensional change in the absorption axis direction as referred to herein is represented by:

$$\text{ratio of dimensional change} = [(L_0 - L_1) / L_0] \times 100 \quad \text{[II]},$$

wherein L_0 (in mm) represents a length of the polarizing plate in the direction of the absorption axis before it is heated and L_1 (in mm) represents a length of the polarizing plate in the direction of the absorption axis after it is heated. The ratio of dimensional change in the transmission axis direction is the same as the ratio of dimensional change in the absorption axis direction except that the lengths are those in the direction of the transmission axis.

The above absorption and transmission axes are more specifically the absorption and transmission axes of a polarizer that a polarizing plate has. The ratio of dimensional change can specifically be measured in a method described in the item of Examples described hereinafter.

Under a high temperature environment a polarizing plate shrinks more in the absorption axis direction, and in particular, the ratio of dimensional change in absorption axis **50a** direction of back-side polarizing plate **50**, which is dimensionally larger in the direction of the absorption axis, will be dominant in causing the front-plate-integrated liquid crystal display panel's warping. The set of polarizing plates that satisfies the above formula [I] can suitably balance ratio of dimensional change R_a in absorption axis **50a** direction of back-side polarizing plate **50** that is dominant in causing the warping and ratio of dimensional change F_t in transmission axis **30b** direction of front-side polarizing plate **30**, which is also larger in dimension in the direction of transmission axis **30b**, and when the set of polarizing plates is applied in a front-plate-integrated liquid crystal display panel and placed in a high temperature environment, it can effectively suppress an amount of warping of the panel, and for example even in a condition in which the front-plate-integrated liquid crystal display panel is heated at 85° C. for 240 hours, the amount of warping of the front-plate-integrated liquid crystal display panel can be suppressed to 0.5 mm or less in absolute value. Note that the amount of warping of the front-plate-integrated liquid crystal display panel is measured in a method described in the item of Examples described hereinafter.

Ratio of dimensional change F_a in the absorption axis direction of front-side polarizing plate **30** is preferably 1.2 to 3.0%, more preferably 1.3 to 2.0%. Ratio of dimensional change F_a exceeding 3.0% results in an excessively large amount of shrinkage and there is a possibility that in a high temperature environment front-side polarizing plate **30** may peel off liquid crystal cell **60**. For the same reason, ratio of dimensional change F_t in the transmission axis direction of front-side polarizing plate **30** is preferably 0.1 to 2.0%, more preferably 0.2 to 1.0%. Ratio of dimensional change R_a in the absorption axis direction of back-side polarizing plate **50** is preferably 0.8 to 3.0%, more preferably 1.0 to 2.0%. Ratio of dimensional change R_t in the transmission axis direction of back-side polarizing plate **50** is preferably 0.1 to 2.0%, more preferably 0.1 to 1.0%. When ratio of dimensional change F_t in the transmission axis direction of front-side polarizing plate **30** or ratio of dimensional change R_t in the

transmission axis direction of back-side polarizing plate **50** is less than 0.1%, the polarizing plate may have impaired optical characteristics.

In order to more effectively suppress the warping amount of the front-plate-integrated liquid crystal display panel, it is more preferable that the left side of the above formula [I], i.e., $(R_a - F_t)$, is smaller. $(R_a - F_t)$ is preferably 1.0% or less, more preferably 0.9% or less, still more preferably 0.8% or less.

The relational formula of the above formula [I] can be achieved for example by increasing polarizer **37** of front-side polarizing plate **30** to be larger in thickness than polarizer **57** of back-side polarizing plate **50**. This is because the smaller in thickness a polarizer is, the smaller a ratio of dimensional change is.

Polarizers **37**, **57** used for front-side polarizing plate **30** and back-side polarizing plate **50** are not particularly limited, and for example, polyvinyl alcohol-based resin film having a dichroic colorant (iodine, an organic dye or the like) adsorbed and oriented therein is suitably used. The polyvinyl alcohol-based resin configuring polarizers **37**, **57** can be obtained by saponifying polyvinyl acetate-based resin. Examples of the polyvinyl acetate-based resin include polyvinyl acetate that is a homopolymer of vinyl acetate, a copolymer of vinyl acetate and other monomer copolymerizable with vinyl acetate and the like. Other monomers copolymerizable with vinyl acetate can for example be unsaturated carboxylic acids, olefins, vinyl ethers, unsaturated sulfonic acids, acrylamides having an ammonium group, and the like. The degree of saponification of the polyvinyl alcohol-based resin is normally approximately 85 to 100 mol %, preferably 98 mol % or greater. The polyvinyl alcohol-based resin may be modified, and, for example, polyvinyl formal, polyvinyl acetal, etc. modified with aldehydes can also be used.

The degree of polymerization of the polyvinyl alcohol-based resin is normally approximately 1000 to 10,000, preferably approximately 1500 to 5000. The polyvinyl alcohol-based resin and the dichroic colorant are specifically exemplified by those indicated in Japanese Patent Laying-Open No. 2012-159778 as examples.

A film formed of the above polyvinyl alcohol-based resin is used as a raw film for polarizers **37**, **57**. The method of forming a film of the polyvinyl alcohol-based resin is not limited to any particular method, and the film can also be formed in a known method. Although the thickness of the raw film formed of the polyvinyl alcohol-based resin is not limited to a particular thickness, it is approximately 1 to 150 μm , for example. Further taking ease of stretching into consideration, the thickness is preferably 10 μm or more.

Polarizers **37**, **57** can be produced for example by a step of uniaxially stretching the above-described polyvinyl alcohol-based resin film, a step of coloring the polyvinyl alcohol-based resin film with the dichroic colorant to cause the film to adsorb the dichroic colorant, a step of treating the polyvinyl alcohol-based resin film that has the dichroic colorant adsorbed therein with an aqueous solution of boric acid, a step of washing the film with water after the treatment with the aqueous solution of boric acid, and finally drying the film. In the process for producing polarizers **37**, **57**, the polyvinyl alcohol-based resin film may be stretched, colored, treated with boric acid, washed with water, and dried pursuant to a method described for example in Japanese Patent Laying-Open No. 2012-159778. The method described in this document does not use the raw film formed of the above polyvinyl alcohol-based resin; rather, a substrate film is coated with polyvinyl alcohol-based resin to

form a polyvinyl alcohol-based resin layer serving as a polarizer, on which a protective layer is laminated to produce a polarizing plate.

The thickness of polarizers **37**, **57** can be approximately 2 to 40 μm , and is preferably approximately 3 to 30 μm .

The protective layer stuck on at least one surface of polarizers **37**, **57** can be layer made of transparent resin, and preferably it is made of a resin which is excellent in transparency, uniform optical characteristics, mechanical strength, thermal stability, etc. Specific examples of the transparent resin that configures the protective layer include cellulose-based resin such as triacetyl cellulose and diacetyl cellulose; polyester-based resin such as polyethylene terephthalate, polyethylene isophthalate, and polybutylene terephthalate; (metha)acrylic resin such as polymethyl (metha)acrylate and polyethyl(metha)acrylate; polycarbonate-based resin; polyether sulfone-based resin; polysulfone-based resin; polyimide-based resin; polyolefin-based resin such as polyethylene and polypropylene; and polynorbornene-based resin.

When protective layers **35a** and **35b** are laminated on the opposite surfaces of polarizer **37**, these protective layers **35a** and **35b** may be identical or different. The same applies to protective layers **55a** and **55b** of polarizer **57**.

Preferably, at least one of front-side polarizing plate **30** and back-side polarizing plate **50** includes a liquid-crystal-cell-side protective layer laminated on a surface of the polarizer closer to liquid crystal cell **60** and this liquid-crystal-cell-side protective layer has an in-plane phase retardation. For example, in front-side polarizing plate **30**, protective layer **35b** stuck on a side of polarizer **37** closer to liquid crystal cell **60** can be a protective layer having an in-plane phase retardation. Furthermore, for example, in back-side polarizing plate **50**, protective layer **55a** stuck on a side of polarizer **57** closer to liquid crystal cell **60** can be a protective layer having an in-plane phase retardation.

The in-plane phase retardation of the protection layer can be provided by uniaxial stretching or biaxial stretching. While an in-plane phase retardation value R_0 may be set as appropriate in accordance with the type of liquid crystal cell **60** applied, generally it is set preferably to 30 nm or more. In-plane phase retardation value R_0 has an upper limit for example of approximately 300 nm. In-plane phase retardation value R_0 is defined by the following formula:

$$R_0 = (n_x - n_y) \times d \quad \text{[III]}$$

where n_x represents a refractive index of the protective layer in the direction of an in-plane slow axis thereof, n_y represents a refractive index of the protective layer in the direction of an in-plane fast axis thereof (i.e., a direction orthogonal to the direction of the in-plane slow axis), and d represents the thickness of the protective layer.

The protective layers that front-side polarizing plate **30** and back-side polarizing plate **50** may have normally have a thickness of approximately 5 to 200 μm , preferably 10 μm or more, and preferably 80 μm or less, more preferably 40 μm or less.

The polarizer and the protective layer can be stuck together using an adhesive or a pressure sensitive adhesive. The adhesive can be an aqueous adhesive containing polyvinyl alcohol-based resin, urethane resin or the like as a major component; a photo-curing type adhesive including photo-curing type resin such as ultraviolet curing type resin (epoxy-based resin etc.); and/or the like. The pressure sensitive adhesive can be that with an acrylic polymer, a silicone-based polymer, polyester, polyurethane, polyether, etc. as a base polymer. Before being stuck on the polarizer,

the surface of the protective layer at which the protective layer is stuck on the polarizer may undergo a saponification treatment, a corona treatment, primer treatment, anchor coating treatment and/or the like to help adhesion.

When front-side polarizing plate **30** includes protective layer **35a** laminated on the viewing side of polarizer **37**, protective layer **35a** may have an external surface provided with a surface treatment layer such as a hard coat layer, an antireflection layer, an anti-glare layer and/or the like, if necessary. The hard coat layer is a surface treatment layer to prevent a scratch of a surface of front-side polarizing plate **30**, and its constituent material is selected from ultraviolet curing type resin, e.g., among acrylic resin, silicone-based resin and/or the like, with its adhesiveness to protective layer **35a**, its hardness and the like considered.

The antireflection layer is a surface treatment layer formed for the purpose of preventing reflection of external light at a surface of front-side polarizing plate **30** and can be formed in a known method. The anti-glare layer is a surface treatment layer formed to prevent reduced visibility resulting from a glare of external light in a surface of front-side polarizing plate **30**, and generally the anti-glare layer is formed for example by roughening the layer surface such as sandblasting, embossing, or the like; mixing transparent fine particles with an ultraviolet curing type resin; or the like to allow protective layer **35a** to have a surface with an irregular structure.

Front-side polarizing plate **30** and/or back-side polarizing plate **50** can have one or more optical layers other than the polarizer and the protective layer and presenting an optical function different than the polarizing plate. Specific examples of the other optical layers include a reflective layer, a semitransparent reflective layer, a phase retardation plate, and a brightness enhancement film by way of example. For example, front-side polarizing plate **30** and/or back-side polarizing plate **50** can be: an elliptically or circularly polarizing plate having the phase retardation plate further laminated on the above-described polarizing plate including a polarizer and a protective layer; a polarizing plate having one protective layer serving as an angle-of-visibility compensation film; a polarizing plate having the brightness enhancement film further laminated on the above-described polarizing plate including a polarizer and a protective layer; or the like.

The phase retardation plate is a so-called λ plate (a $1/2\lambda$ plate or a $1/4\lambda$ plate) that can form a composite polarizing plate of an elliptical or circular polarization mode that is used for an image display device used in a mobile application, in particular, and the phase retardation plate can be laminated on the above-described protective layer. The composite polarizing plate of the elliptical or circular polarization mode has a function so that when the incident polarization direction is linear polarization it is changed to elliptical polarization or circular polarization and when the incident polarization direction is elliptical or circular polarization it is changed to linear polarization. In particular, as a phase retardation plate that can change elliptical polarization or circular polarization to linear polarization and can change linear polarization to elliptical polarization or circular polarization, what is called a $1/4\lambda$ plate is used. Furthermore, a $1/2\lambda$ plate has a function to change linear polarization in direction.

A specific example of the phase retardation plate is a stretched film obtained by stretching a resin film selected from polycarbonate-based resin film, polyvinyl alcohol-based resin film, polystyrene-based resin film, polymethyl methacrylate-based resin film, polyolefin-based resin film

such as polypropylene, polyarylate-based resin film, polyamide-based resin film, polyolefin-based resin film, polynorbornene-based resin film, and the like. Such a stretched film can be a film processed in an appropriate method such as a uniaxial stretching, biaxial stretching or the like. Furthermore, the phase retardation plate may be a birefringent film controlled in refractive index in the thickness direction of the film by applying shrinking force and/or stretching force to the film under the condition where the film is adhered to a heat shrinkable film.

The brightness enhancement film is used for the purpose of improvement in brightness in liquid crystal display devices etc., and its specific examples include a reflection type polarization separation sheet designed to introduce anisotropy in reflectance by laminating a plurality of thin films mutually different in refractive index anisotropy, and a circular polarization separation sheet formed of a film substrate and an oriented film of a cholesteric liquid polymer, an oriented liquid crystal layer thereof or the like supported on the film substrate.

The above optical layer can be integrated with the polarizing plate using a pressure sensitive adhesive or an adhesive. The pressure sensitive adhesive or adhesive used is not limited to any specific ones and may be any pressure sensitive adhesive or adhesive selected as appropriate. Preferably, the pressure sensitive adhesive is used in view of convenience in a bonding process, prevention of optical distortion, etc. The pressure sensitive adhesive is not limited to any specific one and can for example be that with an acrylic polymer, a silicone-based polymer, polyester, polyurethane, polyether, etc. as a base polymer. Inter alia, it is preferable to select and use a pressure sensitive adhesive that is excellent in transparency, holds appropriate wettability and cohesive strength, also presents excellent adhesion to the polarizing plate and the optical layer, and furthermore, has satisfactory thermal resistance and can avoid problems such as loosening, peeling and the like in a high temperature environment, such as an acrylic pressure sensitive adhesive.

The layer made of the pressure sensitive adhesive for sticking the optical layer may contain fine particles for presenting a light-scattering property if necessary, and may contain glass fiber, glass beads, resin beads, a filler such as metallic powder or other inorganic powder, a pigment, a coloring agent, an antioxidant, an ultraviolet absorber, etc. Examples of the ultraviolet absorber include a salicylic acid ester-based compound, a benzophenone-based compound, a benzotriazol-based compound, a cyanoacrylate-based compound, a nickel complex salt-based compound, and the like.

Back-side polarizing plate **50** preferably has the above-described, one or more other optical layers laminated on an outermost surface opposite to liquid crystal cell **60**, and the optical layer(s) that back-side polarizing plate **50** has on the above outermost surface thereof can be a brightness enhancement film or the like.

<Front-Plate-Integrated Liquid Crystal Display Panel>

A front-plate-integrated liquid crystal display panel according to the present invention is a liquid crystal display panel having front-plate-integrated polarizing plate **40** and back-side polarizing plate **50** stuck on liquid crystal cell **60**. FIG. 2 is a cross-sectional view schematically showing an example of a preferable layer configuration in a front-plate-integrated liquid crystal display panel according to the present invention, and shows front-plate-integrated liquid crystal display panel **80** formed by sticking the polarizing plate set as shown in FIG. 1 (front-plate-integrated polarizing plate **40** and back-side polarizing plate **50**) on liquid crystal cell **60**.

As shown in FIG. 2, front-plate-integrated polarizing plate **40** is stuck to the viewing side of liquid crystal cell **60** so that front plate **10** faces toward the viewing side, i.e., front-side polarizing plate **30** side of front-plate-integrated polarizing plate **40** is stuck to the viewing side of liquid crystal cell **60**. Back-side polarizing plate **50** is stuck to the back side of liquid crystal cell **60**. Front-plate-integrated polarizing plate **40** and back-side polarizing plate **50** can be stuck on liquid crystal cell **60** using a pressure sensitive adhesive. The pressure sensitive adhesive can for example be that with an acrylic polymer, a silicone-based polymer, polyester, polyurethane, polyether, etc. as a base polymer. Inter alia, it is preferable to use an acrylic pressure sensitive adhesive as it is excellent in optical transparency, has satisfactory thermal resistance and is thus less liable to problems such as loosening, peeling and the like in a high temperature environment, and is also advantageous in preventing impaired optical characteristics attributed to a thermal expansion difference or the like, suppressing the front-plate-integrated liquid crystal display panel's warping attributed to a thermal expansion difference or the like.

Normally, before the polarizing plates are stuck on liquid crystal cell **60**, a pressure sensitive adhesive layer formed of the above pressure sensitive adhesive is previously laminated on an outermost surface of each polarizing plate that is closer to liquid crystal cell **60**. Preferably, an outer surface of the pressure sensitive adhesive layer is temporarily protected by a separator for the purpose of preventing contamination and so on until the pressure sensitive adhesive layer is served for practical use. The separator can be composed of a resin film substrate pursuant to the above protective layer and a peeling coat layer disposed on the resin film substrate and provided by a similar appropriate peeling agent such as a silicone-based peeling agent, a long chain alkyl-based peeling agent, a fluorine-based peeling agent, molybdenum sulfide or the like if necessary. Front-plate-integrated polarizing plate **40** and back-side polarizing plate **50** are stuck such that their shorter sides are parallel to the shorter sides of liquid crystal cell **60**.

A driving mode of liquid crystal cell **60** may be any conventionally known mode such as a VA mode, an IPS mode, a TN mode, or the like, and front-plate-integrated polarizing plate **40** and back-side polarizing plate **50** are stuck on a liquid crystal cell substrate, which can be made of glass, transparent resin, etc.

Front-plate-integrated liquid crystal display panel **80** of the present invention employs the above-described set of polarizing plates. Therefore, when it is heated at 85° C. for 240 hours, its warping amount in absolute value can be 0.5 mm or less, furthermore 0.4 mm or less, still furthermore 0.3 mm or less. Thus, front-plate-integrated liquid crystal display panel **80** of the present invention can suppress warping in a high temperature environment, and can be easily accommodated in a casing for a final product even after it is placed in the high temperature environment.

EXAMPLES

The present invention will be described more specifically below by way of Examples, but the present invention is not limited by these Examples. In Examples, % and part(s) expressing the content or the use amount are based on weight, unless otherwise indicated.

Example 1

A front-plate-integrated liquid crystal display panel having a layer configuration shown in FIG. 2 was fabricated in the following procedure.

(1) Fabrication of Front-Side Polarizing Plate 30

A 60 μm -thick polyvinyl alcohol film (with an average polymerization degree of approximately 2400 and a degree of saponification of 99.9 mol % or more) was uniaxially stretched by dry stretching with a stretching magnification of approximately five times and was immersed in pure water of 60° C. for one minute while maintaining the tension of the film and subsequently, immersed in an aqueous solution in which a weight ratio of iodine/potassium iodide/water was 0.05/5/100 at 28° C. for 60 seconds. Thereafter the film was immersed in an aqueous solution in which a weight ratio of potassium iodide/boric acid/water was 8.5/8.5/100 at 72° C. for 300 seconds. Subsequently, the film was washed with pure water of 26° C. for 20 seconds, and thereafter dried at 65° C. to obtain polarizer 37 having a thickness of 23 μm and formed of the polyvinyl alcohol film with iodine adsorbed and oriented therein.

Then, on one surface of polarizer 37 thus obtained, a water-based epoxy-based adhesive, which was prepared by dissolving 3 parts of a carboxyl group-modified polyvinyl alcohol [trade name: "KL-318" obtained from Kuraray Co., Ltd.] in 100 parts of water to obtain an aqueous solution and adding into the aqueous solution 1.5 parts of a polyamide epoxy-based additive of water-soluble epoxy resin [trade name: "Sumirez Resin 650(30)" produced by Taoka Chemical Co., Ltd., an aqueous solution having a solid content concentration of 30%], was applied and protective layer 35a of a 40 μm -thick triacetyl cellulose film [trade name: "KC4UY" produced by Konica Minolta Opto Inc.] was stuck thereon, and on an opposite side of polarizer 37, protective layer 35b of a non-stretched film having a thickness of 23 μm and made of norbornene-based resin [trade name: "ZEONOR" produced by Nippon Zeon Co., Ltd.] was stuck using the aforementioned adhesive.

(2) Fabrication of Back-Side Polarizing Plate 50

A 30 μm -thick polyvinyl alcohol film (with an average polymerization degree of approximately 2400 and a degree of saponification of 99.9 mol % or more) was uniaxially stretched by dry stretching with a stretching magnification of approximately five times and was immersed in pure water of 60° C. for one minute while maintaining the tension of the film and subsequently, immersed in an aqueous solution in which a weight ratio of iodine/potassium iodide/water was 0.05/5/100 at 28° C. for 60 seconds. Thereafter the film was immersed in an aqueous solution in which a weight ratio of potassium iodide/boric acid/water was 8.5/8.5/100 at 72° C. for 300 seconds. Subsequently, the film was washed with pure water of 26° C. for 20 seconds, and thereafter dried at 65° C. to obtain polarizer 57 having a thickness of 11 μm and formed of the polyvinyl alcohol film with iodine adsorbed and oriented therein.

Then, on polarizer 57 thus obtained, the same method as that employed for front-side polarizing plate 30 was employed with the same epoxy-based adhesive as above to stick protective layer 55a of the above-mentioned "ZEONOR" of 23 μm in thickness and protective layer 55b of triacetyl cellulose film [trade name: "KC2UA" produced by Konica Minolta Opto Inc.] of 25 μm thickness.

(3) Fabrication of Front-Plate-Integrated Liquid Crystal Display Panel

On an outer surface of protective layer 35a of front-side polarizing plate 30 obtained above at item (1), a pressure sensitive adhesive [trade name: "#KZ" produced by Lintec Corporation, an acrylic pressure sensitive adhesive] was applied to form a pressure sensitive adhesive layer of 20 μm in thickness. Furthermore, on an outer surface of protective layer 55a of back-side polarizing plate 50 obtained above at

item (2), a pressure sensitive adhesive [trade name: "#KZ" produced by Lintec Corporation, an acrylic pressure sensitive adhesive] was applied to form a pressure sensitive adhesive layer of 20 μm in thickness.

Then front-side polarizing plate 30 having the pressure sensitive adhesive layer was cut to have a size of 5 inches such that the absorption axis of polarizer 37 was parallel to the shorter side of liquid crystal cell 60, and back-side polarizing plate 50 having the pressure sensitive adhesive layer was also cut to have a size of 5 inches such that the absorption axis of polarizer 57 was parallel to the longer side of liquid crystal cell 60. The two polarizing plates cut as above were then stuck on liquid crystal cell 60 via their respective pressure sensitive adhesive layers, so that the shorter sides of the two polarizing plates were parallel to the shorter sides of liquid crystal cell 60.

Then on the protective layer 35a side of front-side polarizing plate 30 an ultraviolet curing type optical elastic resin [trade name: "Super View Resin" produced by Dexerials Corporation] was applied and thereon front plate 10 having a Young's modulus of 70 GPa and having a thickness of 0.55 mm [trade name: "Gorilla" produced by Corning Incorporated] was laminated. Then ultraviolet rays ["D valve" produced by Fusion UV Systems Inc., integrated quantity of light: 1200 mJ/cm²] was emitted from the front plate 10 side to thus fabricate a front-plate-integrated liquid crystal display panel.

Example 2

A front-plate-integrated liquid crystal display panel was fabricated in the following procedure. Note that while in the following description the reference characters indicated in FIG. 1 and FIG. 2 are used, unlike these figures, back-side polarizing plate 50 fabricated in the present example does not have protective layer 55a closer to liquid crystal cell 60 and a brightness enhancement film is laminated on an outer surface of protective layer 55b of back-side polarizing plate 50.

(1) Fabrication of Front-Side Polarizing Plate 30

Front-side polarizing plate 30 identical to Example 1, item (1) was fabricated.

(2) Fabrication of Back-Side Polarizing Plate 50

Acetoacetyl group modified polyvinyl alcohol powder having an average polymerization degree of 1100 and a degree of saponification of 99.5 mol % [trade name: "Gohsefimer Z-200" produced by The Nippon Synthetic Chemical Industry Co., Ltd.] was dissolved in hot water of 95° C. to prepare an aqueous solution of a concentration of 3%. Into this aqueous solution, a cross-linking agent of a water-soluble polyamide epoxy resin [trade name: "Sumirez Resin 650" produced by Taoka Chemical Co., Ltd., an aqueous solution having a solid content concentration of 30%] was mixed at a ratio of 5 parts per 6 parts of a solid content of polyvinyl alcohol to prepare a coating liquid for primer. Then a substrate film (a polypropylene film having a thickness of 110 μm and a melting point of 163° C.) was subjected to a corona treatment and the corona-treated surface was coated with the coating liquid for primer using a micro gravure coater. The substrate film was then dried at 80° C. for 10 minutes to form a 0.2 μm -thick primer layer.

Then, polyvinyl alcohol powder having an average polymerization degree of 2400 and a degree of saponification of 98.0 to 99.0 mol % [trade name: "PVA124" obtained from Kuraray Co., Ltd.] was dissolved in hot water of 95° C. to prepare an aqueous solution of polyvinyl alcohol of a concentration of 8%. The obtained aqueous solution was

applied on the primer layer of the above substrate film using a lip coater at room temperature, and dried at 80° C. for 20 minutes to provide a laminated film composed of the substrate film/the primer layer/a polyvinyl alcohol layer.

Then the obtained laminated film was subjected to a free end longitudinal uniaxial stretching treatment at 160° C. with a stretching magnification of 5.8 times. The stretched laminated film thus obtained had a total thickness of 28.5 μm and the polyvinyl alcohol layer had a thickness of 5.0 μm.

The stretched laminated film thus obtained was immersed in an aqueous solution in which a weight ratio of water/iodine/potassium iodide was 100/0.35/10 at 26° C. for 90 seconds so as to be colored, and thereafter the film was washed with pure water of 10° C. The stretched laminated film was then immersed in an aqueous solution in which a weight ratio of water/boric acid/potassium iodide was 100/9.5/5 at 76° C. for 300 seconds to crosslink the polyvinyl alcohol. Then, the film was washed with pure water of 10° C. for 10 seconds and finally dried at 80° C. for 200 seconds. A polarizing laminated film was thus fabricated that was composed of a polypropylene substrate film and polarizer 57 deposited on the film substrate and formed of a polyvinyl alcohol layer having iodine adsorbed and oriented therein.

Then, on a surface of the obtained polarizing laminated film opposite to the substrate film, (i.e., on a polarizer surface), a water-based epoxy-based adhesive, which was prepared by dissolving 3 parts of a carboxyl group-modified polyvinyl alcohol [trade name: "KL-318" obtained from Kuraray Co., Ltd.] in 100 parts of water to obtain an aqueous solution and adding into the aqueous solution 1.5 parts of a polyamide epoxy-based additive of water-soluble epoxy resin [trade name: "Sumirez Resin 650(30)" produced by Taoka Chemical Co., Ltd., an aqueous solution having a solid content concentration of 30%], was applied and protective layer 55b of a 25 μm-thick triacetyl cellulose film [trade name: "KC2UA" produced by Konica Minolta Opto Inc.] was stuck thereon, and the substrate film is alone peeled off and a polarizing plate made of protective layer 55b/polarizer 57/a primer layer was thus obtained.

Thereafter, on an outer surface of protective layer 55b, a 5 μm-thick pressure sensitive adhesive [trade name: "#L2" produced by Lintec Corporation, an acrylic pressure sensitive adhesive] was stuck to form a pressure sensitive adhesive layer and thereafter, a brightness enhancement film of 26 μm in thickness [trade name: "Advanced Polarized Film, Version 3" produced by 3M Company] was stuck thereon.

(3) Fabrication of Front-Plate-Integrated Liquid Crystal Display Panel

Except that front-side polarizing plate 30 and back-side polarizing plate 50 obtained in the present example at items (1) and (2) above were used, a front-plate-integrated liquid crystal display panel was fabricated by the same method as described in Example 1.

Comparative Example 1

Except that back-side polarizing plate 50 fabricated as described in Example 1 at item (2) was used as front-side polarizing plate 30 and that front-side polarizing plate 30 fabricated as described in Example 1 at item (1) was used as back-side polarizing plate 50, a front-plate-integrated liquid crystal display panel was fabricated by the same method as described in Example 1.

Ratios of dimensional change F_a and F_t in the absorption and transmission axes directions of front-side polarizing plates 30 of Examples 1 and 2 and Comparative Example 1 (in a state without being integrated with front plate 10) in a

high temperature environment, ratios of dimensional change R_a and R_t in the absorption and transmission axes directions of back-side polarizing plates 50 of the examples in the high temperature environment, and the amounts of warping of the front-plate-integrated liquid crystal display panels of the examples in the high temperature environment were measured in the following method. An obtained result is shown in table 1.

(Ratio of Dimensional Change of Polarizing Plate)

A test piece for measuring the amount of shrinkage was cut out of the obtained polarizing plate. The shape of the test piece was a square or a rectangle having two opposite sides parallel to a stretching direction (that is, an absorption axis direction of the polarizer) and the sides parallel to the stretching direction had a length of 30 to 50 mm and the sides orthogonal thereto had a length of 20 to 50 mm. This test piece was left in an environment of 85° C. for 100 hours. A length L_0 in the direction of the absorption axis and the direction of the transmission axis orthogonal thereto before being left in the environment of 85° C. for 100 hours and a length L_1 in the direction of the absorption axis and the direction of the transmission axis orthogonal thereto after being left in the environment were measured using a two-dimensional measuring instrument "NEXIV VMR-12072" produced by Nikon Corporation, and the following formula:

$$\text{ratio of dimensional change} = [(L_0 - L_1) / L_0] \times 100 \quad \text{[III]}$$

was employed to obtain ratios of dimensional change F_a , F_t , R_a , R_t .

(Amount of Warping of Front-Plate-Integrated Liquid Crystal Display Panel)

The front-plate-integrated liquid crystal display panel was left in an environment of 85° C. for 240 hours and thereafter, with front plate 10 facing upward, placed on the measuring table of a two-dimensional measurement instrument "NEXIV VMR-12072" produced by Nikon Corporation. The instrument was focused on a surface of the measuring table, and with reference thereto the instrument was focused on the front-plate-integrated liquid crystal display panel at the four corners, the four sides' respective centers, and a surface's center (for a total of 9 points) and measured their distances from the focal point serving as the reference, and a distance from the measuring table that is the largest in absolute value was determined as an amount of warping.

TABLE 1

			Example 1	Example 2	comp. ex. 1
ratio of dimensional change (%)	front side	absorbing axis direction	1.5	1.4	1.4
		transmitting axis direction	0.7	0.4	0.4
	back side	absorbing axis direction	1.4	1.1	1.5
		transmitting axis direction	0.4	0.1	0.7
difference in ratio of dimensional change (%)	$R_a - F_t$		0.7	0.7	1.1
	$F_a - R_t$		1.1	1.3	0.7
amount of warping of liquid crystal display panel (mm)			0.10	0.15	0.56

REFERENCE SIGNS LIST

10: front plate, 20: ultraviolet curing type resin or pressure sensitive adhesive; 30: front-side polarizing plate; 30a: absorption axis of front-side polarizing plate; 30b: transmis-

sion axis of front-side polarizing plate; **35a, 35b**: protective layer of front-side polarizing plate; **37**: polarizer of front-side polarizing plate; **40**: front-plate-integrated polarizing plate; **50**: back-side polarizing plate; **50a**: absorption axis of back-side polarizing plate; **50b**: transmission axis of back-side polarizing plate; **55a, 55b**: protective layer of back-side polarizing plate; **57**: polarizer of back-side polarizing plate; **59**: pressure sensitive adhesive layer of back-side polarizing plate; **60**: liquid crystal cell; **80**: front-plate-integrated liquid crystal display panel.

The invention claimed is:

1. A set of polarizing plates comprising:

a front-plate-integrated polarizing plate to be disposed at a viewing side of a liquid crystal cell, the front-plate-integrated polarizing plate including a front-side polarizing plate and a front plate, the front plate being disposed at a viewing side of the front-side polarizing plate and having a Young's modulus equal to or greater than 2 GPa, the front-side polarizing plate including a polarizer and a first protective layer on a viewing side of the polarizer, the front plate and the first protective layer of the front-side polarizing plate being integrated together by an ultraviolet curing type resin or a pressure sensitive adhesive; and

a back-side polarizing plate to be disposed at a back side of the liquid crystal cell,

the set of polarizing plates satisfying the following formula:

$$(R_a - F_a) < (F_a - R_a) \quad [I],$$

where F_a represents a ratio of dimensional change observed in the front-side polarizing plate in an absorption axis direction after the front-side polarizing plate is heated at 85° C. for 100 hours and F_t represents a ratio of dimensional change observed in the front-side polarizing plate in a transmission axis direction after the front-side polarizing plate is heated at 85° C. for 100 hours, and R_a represents a ratio of dimensional change observed in the back-side polarizing plate in an absorption axis direction after the back-side polarizing plate is heated at 85° C. for 100 hours and R_t represents a ratio of dimensional change observed in the back-side polarizing plate in a transmission axis direction after the back-side polarizing plate is heated at 85° C. for 100 hours.

2. The set of the polarizing plates according to claim 1, wherein:

the back-side polarizing plate includes a polarizer; and

the polarizer of the front-side polarizing plate is larger in thickness than the polarizer of the back-side polarizing plate.

3. The set of polarizing plates according to claim 1, wherein:

the front-side polarizing plate and the back-side polarizing plate have a rectangular shape having a longer side and a shorter side;

the front-side polarizing plate has an absorption axis approximately parallel to a direction of the shorter side; and

the back-side polarizing plate has an absorption axis approximately parallel to a direction of the longer side.

4. The set of polarizing plates according to claim 1, wherein the polarizer of the front-side polarizing plate is composed of a polyvinyl alcohol-based resin film, and wherein the back-side polarizing plate includes a polarizer composed of a polyvinyl alcohol-based resin film and a protective layer laminated on at least one surface of the polarizer of the back-side polarizing plate.

5. The set of polarizing plates according to claim 4, wherein

the front-side polarizing plate includes a liquid-crystal-cell-side protective layer laminated on a surface of the polarizer opposite to the viewing side of the polarizer, the liquid-crystal-cell-side protective layer having an in-plane phase retardation; or

the back-side polarizing plate includes a liquid-crystal-cell-side protective layer laminated on a viewing side surface of the polarizer, the liquid-crystal-cell-side protective layer having an in-plane phase retardation.

6. The set of polarizing plates according to claim 4, wherein the back-side polarizing plate further includes another optical layer other than the polarizer and the protective layer laminated on an outermost surface opposite to the liquid crystal cell.

7. A front-plate-integrated liquid crystal display panel comprising the set of polarizing plates according to claim 1, and the liquid crystal cell, wherein the front-plate-integrated polarizing plate is stuck, at its front-side polarizing plate's side, on a viewing side of the liquid crystal cell, and the back-side polarizing plate is stuck on a back side of the liquid crystal cell.

8. The front-plate-integrated liquid crystal display panel according to claim 7, having a warping amount in absolute value of 0.5 mm or less when heated at 85° C. for 240 hours.

* * * * *

专利名称(译)	一套偏光板和前板集成的液晶显示板		
公开(公告)号	US9606395	公开(公告)日	2017-03-28
申请号	US15/026659	申请日	2014-09-29
[标]申请(专利权)人(译)	住友化学有限公司		
申请(专利权)人(译)	住友化学公司LIMITED		
当前申请(专利权)人(译)	住友化学公司		
[标]发明人	KAWAMURA TAKAHITO		
发明人	KAWAMURA, TAKAHITO		
IPC分类号	G02F1/1335 G02B5/30		
CPC分类号	G02F1/133528 G02B5/3025 G02F2001/133562 G02F2001/133567		
优先权	2013208480 2013-10-03 JP		
其他公开文献	US20160252774A1		
外部链接	Espacenet USPTO		

摘要(译)

本发明提供一组偏振片，其包括设置在液晶盒的观察侧的前板集成偏振片和设置在所述盒的后侧的后侧偏振片。前板集成偏振板包括前侧偏振板和具有2GPa或更大的杨氏模量的前板。该组偏振片满足下式： $(R_a - F_t) \times (F_a - R_t)$ ，其中 F_a 和 F_t 分别表示在吸收和透射轴方向上在前侧偏振片中观察到的尺寸变化的比率。将正面偏振片在85°C下加热100小时，并且 R_a 和 R_t 表示在背面侧偏振片中观察到的尺寸变化的比率。在将背面偏光板在85°C下加热100小时后，分别吸收和透射轴方向。

