

US008780305B2

(12) **United States Patent**
Yoon et al.

(10) **Patent No.:** **US 8,780,305 B2**
(45) **Date of Patent:** **Jul. 15, 2014**

(54) **LIQUID CRYSTAL DISPLAY HAVING WIDE VIEWING ANGLE**

(71) Applicant: **Samsung Display Co., Ltd.**, Yongin (KR)

(72) Inventors: **Yea-Sun Yoon**, Seoul (KR);
Seung-Beom Park, Yongin (KR);
Byoung-Sun Na, Suwon (KR)

(73) Assignee: **Samsung Display Co., Ltd.** (KR)

(*) Notice: Subject to any disclaimer, the term of this patent is extended or adjusted under 35 U.S.C. 154(b) by 0 days.

(21) Appl. No.: **13/865,122**

(22) Filed: **Apr. 17, 2013**

(65) **Prior Publication Data**

US 2013/0229611 A1 Sep. 5, 2013

Related U.S. Application Data

(63) Continuation of application No. 12/483,986, filed on Jun. 12, 2009, now abandoned, which is a continuation of application No. 11/172,953, filed on Jul. 5, 2005, now Pat. No. 7,561,240, which is a continuation of application No. 10/454,478, filed on Jun. 5, 2003, now Pat. No. 6,930,740, which is a continuation of application No. 09/727,782, filed on Dec. 4, 2000, now Pat. No. 6,593,982, which is a continuation-in-part of application No. 09/431,157, filed on Nov. 1, 1999, now Pat. No. 6,717,637.

(30) **Foreign Application Priority Data**

Oct. 30, 1998 (KR) 10-1998-0046153
Feb. 12, 1999 (KR) 10-1999-0054557

(51) **Int. Cl.**

G02F 1/1337 (2006.01)
G02F 1/1343 (2006.01)

(52) **U.S. Cl.**

USPC 349/129; 128/144

(58) **Field of Classification Search**

USPC 349/129, 128, 144
See application file for complete search history.

(56) **References Cited**

U.S. PATENT DOCUMENTS

4,684,218 A	8/1987	Aizawa et al.	
5,309,264 A *	5/1994	Lien et al.	349/143
5,434,690 A	7/1995	Hisatake et al.	
5,608,556 A	3/1997	Koma	
5,652,634 A	7/1997	Hirata et al.	
5,790,219 A	8/1998	Yamagishi et al.	
5,963,290 A	10/1999	Murai et al.	
6,061,106 A	5/2000	Ahn et al.	
6,067,140 A	5/2000	Woo et al.	

(Continued)

FOREIGN PATENT DOCUMENTS

JP	401230025 A	9/1989
JP	05-173142 A	7/1993

(Continued)

Primary Examiner — Jessica M Merlin

(74) *Attorney, Agent, or Firm* — Innovation Counsel LLP

(57) **ABSTRACT**

A liquid crystal display includes a first substrate with pixel electrodes, and a second substrate with a common electrode facing the first substrate. The common electrode has depression patterns corresponding to the pixel electrodes. The side wall of each depression pattern is at an angle of 30-120 degrees with respect to the first substrate. The depression patterns of the common electrode are formed through making depression patterns at color filters. In this structure, the liquid crystal display bears wide viewing angle and good picture quality.

10 Claims, 12 Drawing Sheets

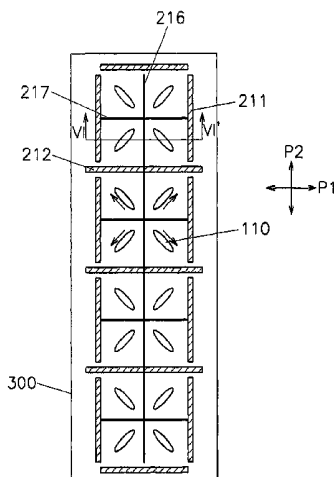

(56)

References Cited

U.S. PATENT DOCUMENTS

6,084,650 A 7/2000 Sekiguchi
6,091,464 A 7/2000 Song
6,100,953 A 8/2000 Kim et al.
6,229,589 B1 5/2001 Koma
6,259,503 B1 7/2001 Watanabe et al.
6,300,987 B1 10/2001 Jung
6,300,996 B1 10/2001 Matsuyama et al.
6,342,938 B1 1/2002 Song et al.
6,369,870 B1* 4/2002 Koma 349/130
6,400,424 B1 6/2002 Kim et al.
6,404,465 B1 6/2002 Nakayama et al.
6,449,025 B2 9/2002 Lee et al.
6,493,048 B1 12/2002 Baek et al.
6,614,492 B1 9/2003 Song
6,654,090 B1 11/2003 Kim et al.

6,717,637 B1 4/2004 Yoon et al.
6,791,647 B1 9/2004 Kim et al.
2005/0264722 A1 12/2005 Choi

FOREIGN PATENT DOCUMENTS

JP 06-308533 A 11/1994
JP 07-311383 A 11/1995
JP 08-110517 A 4/1996
JP 09-281497 A 10/1997
JP 09-318937 A 12/1997
JP 10-260408 A 9/1998
JP 10-333145 A 12/1998
JP 11-242225 A 9/1999
JP 2000-047217 2/2000
JP 2000-162599 6/2000
JP 2001-027754 A 1/2001

* cited by examiner

FIG. 1A

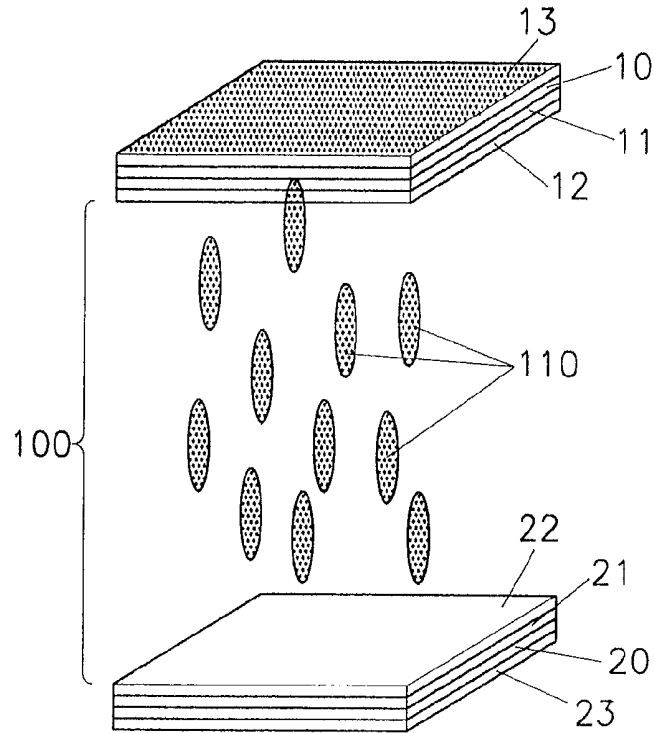

FIG. 1B

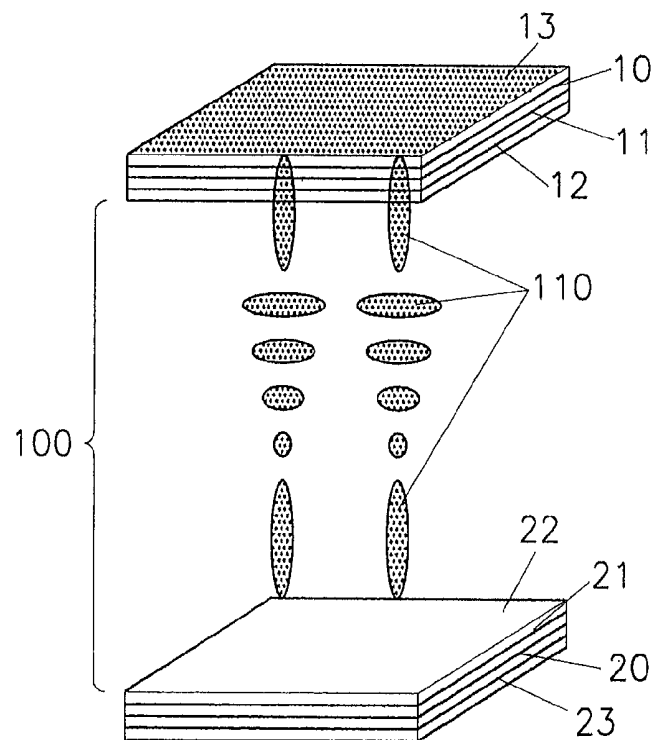

FIG. 2

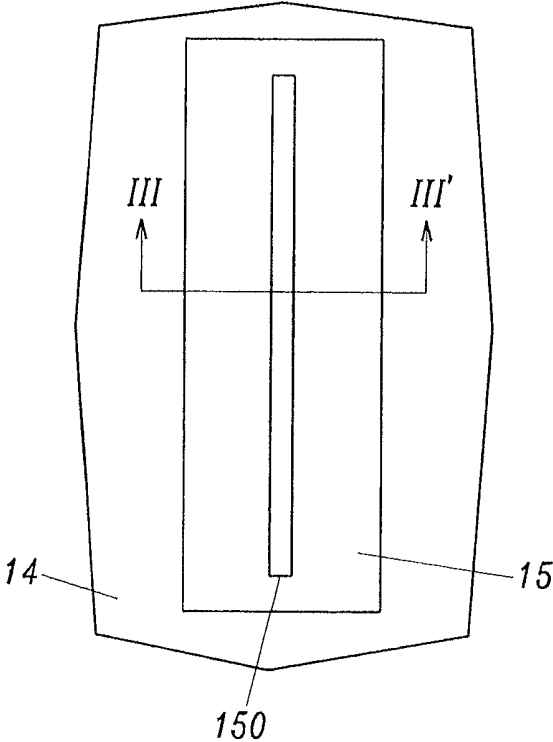

FIG. 3

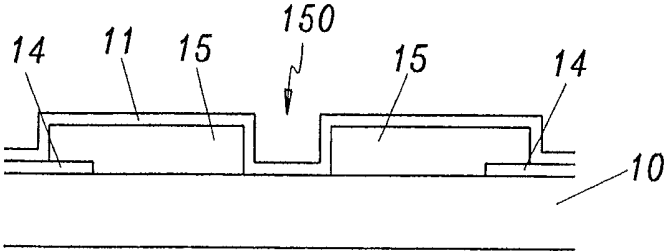

FIG. 4

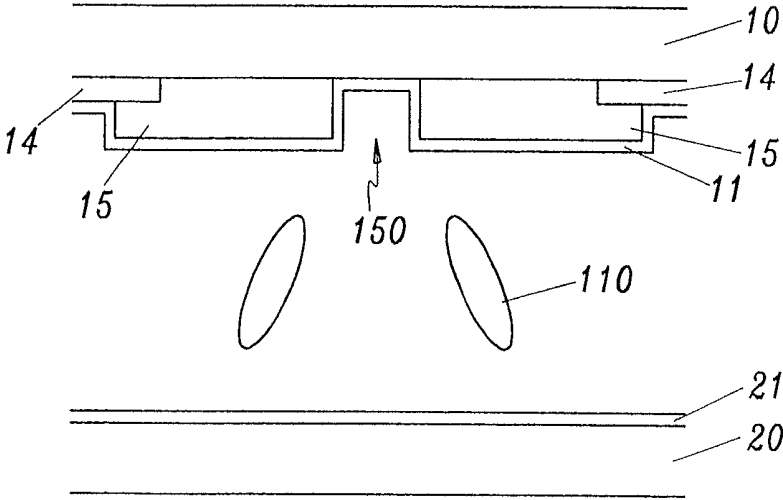

FIG. 5

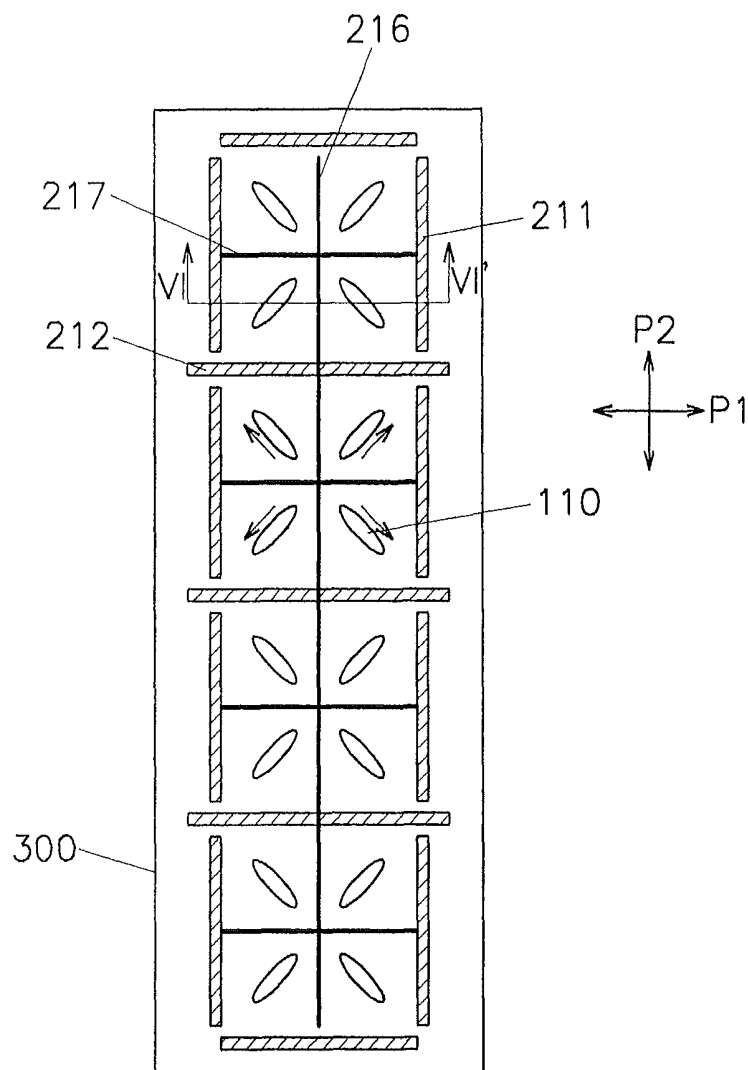

FIG. 6

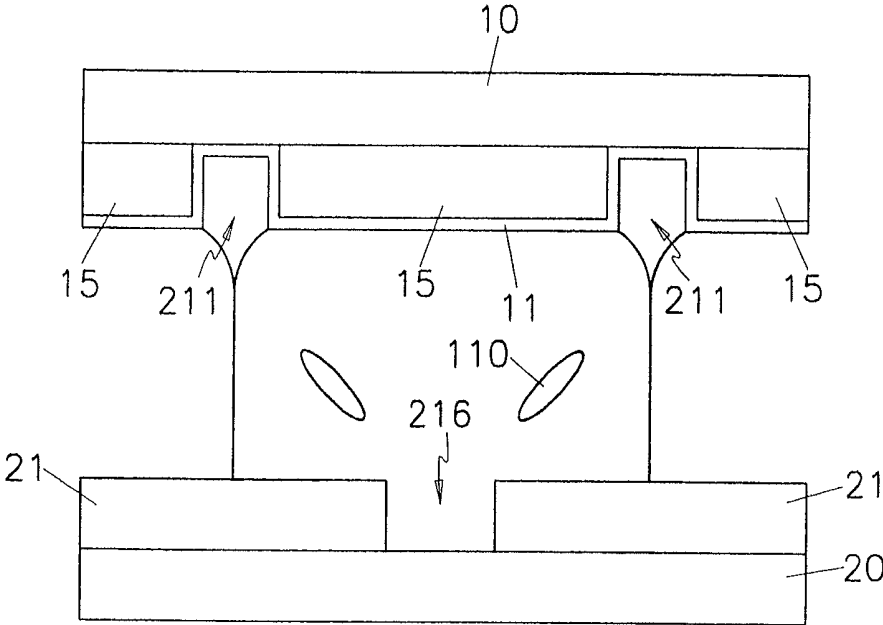

FIG. 7

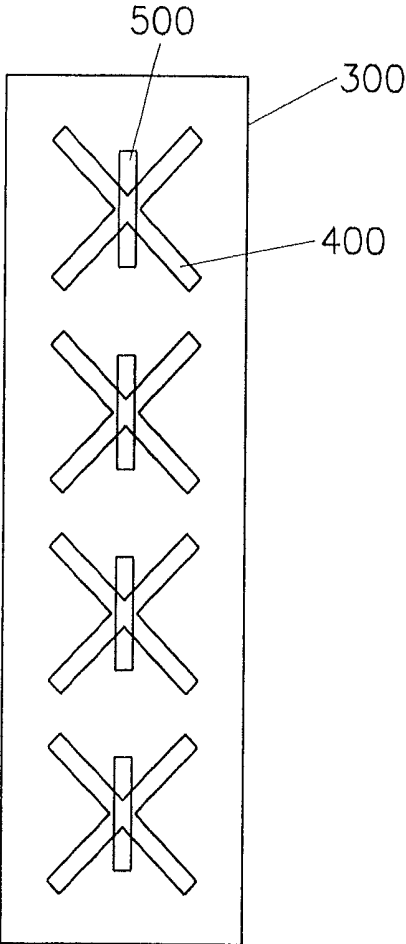

FIG. 8

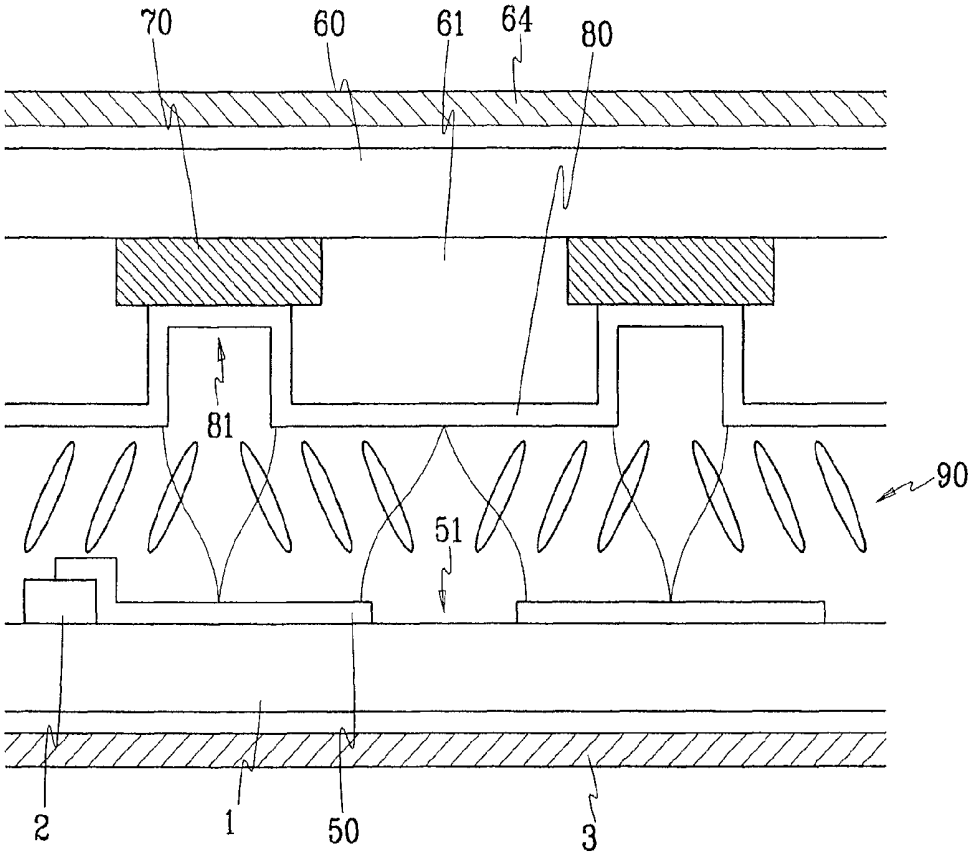

FIG. 9A

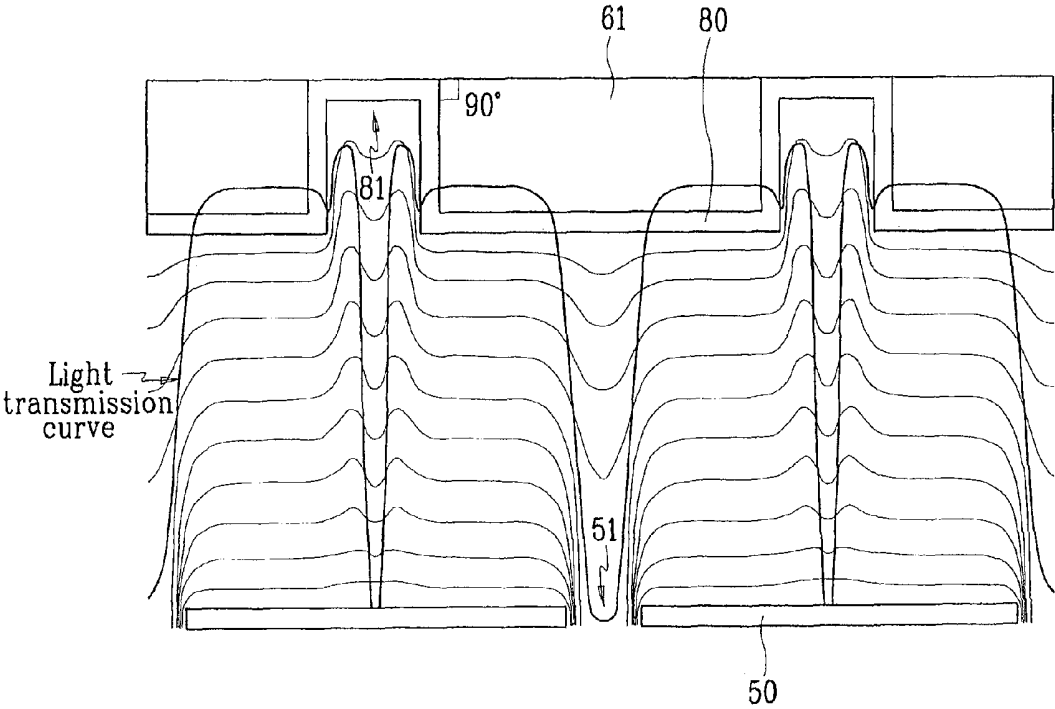

FIG. 9B

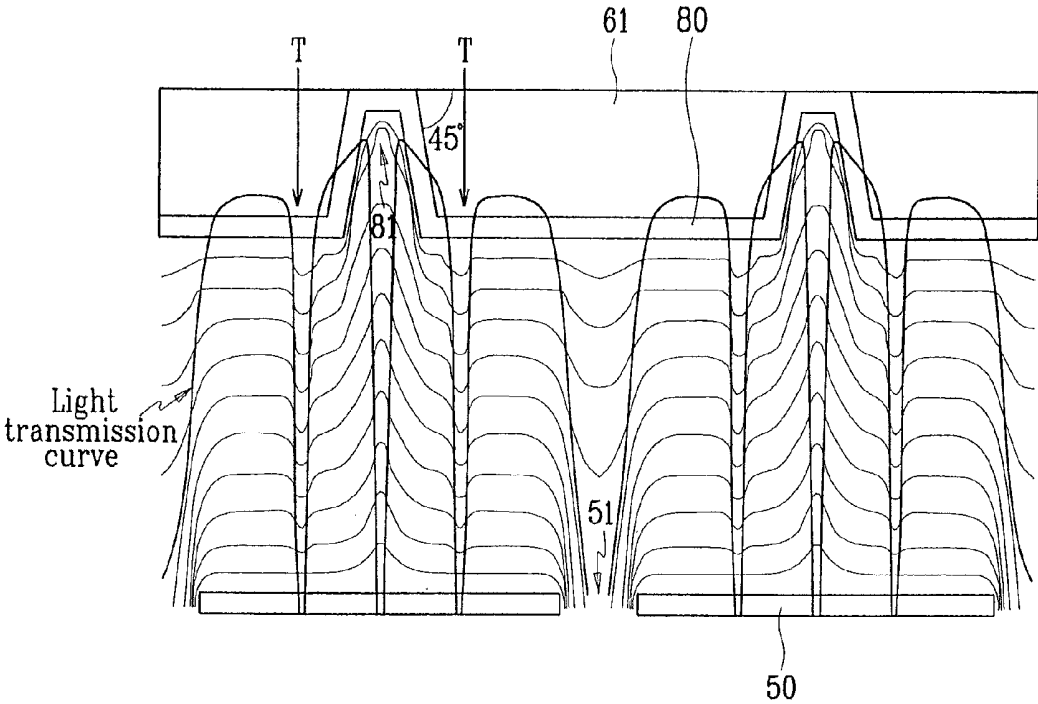

FIG. 10

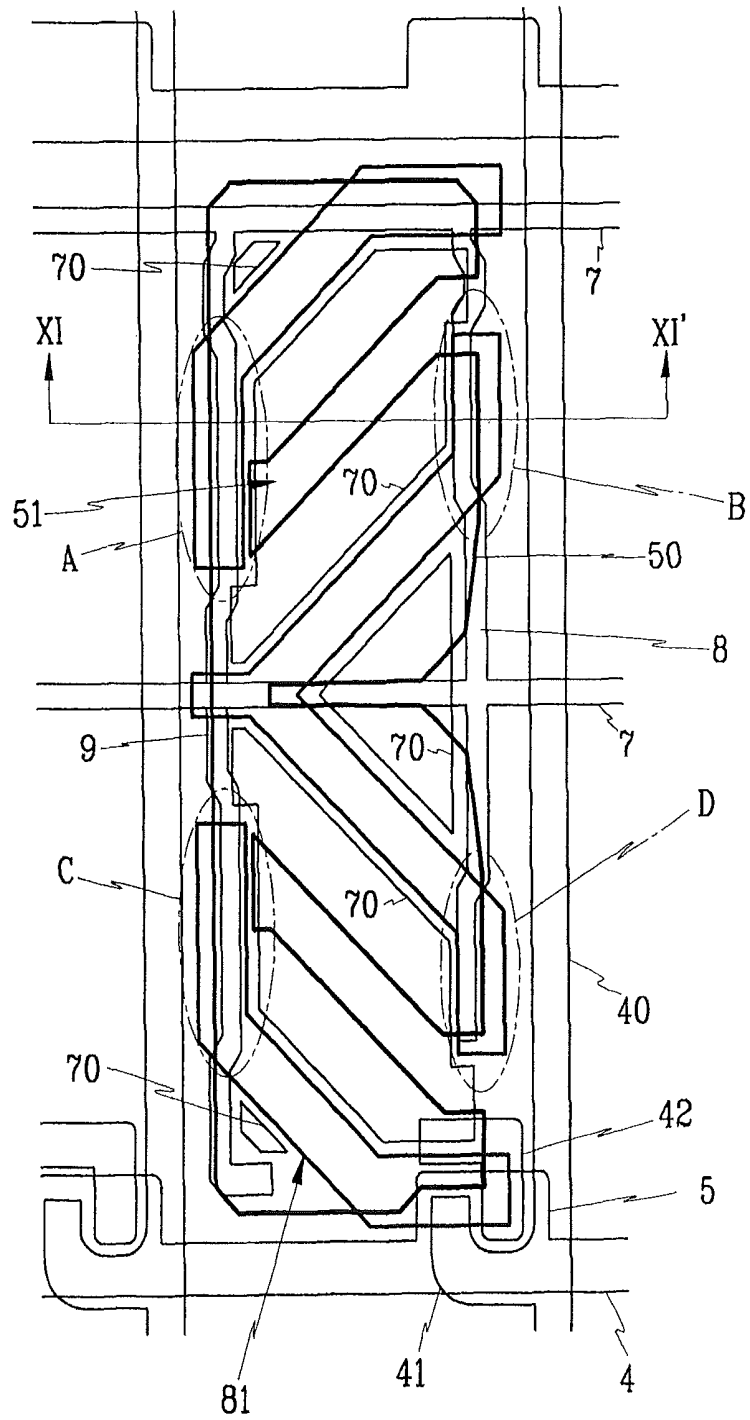

FIG. 11

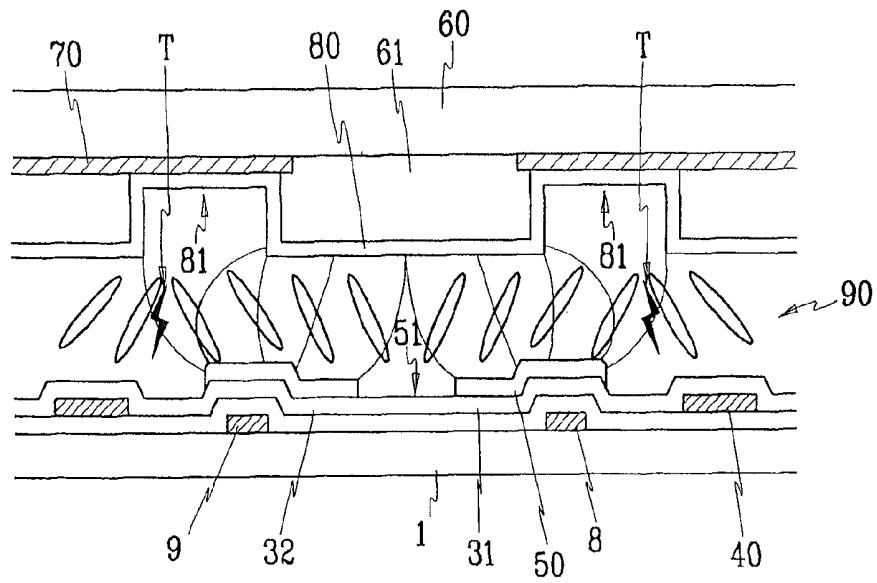

FIG. 12

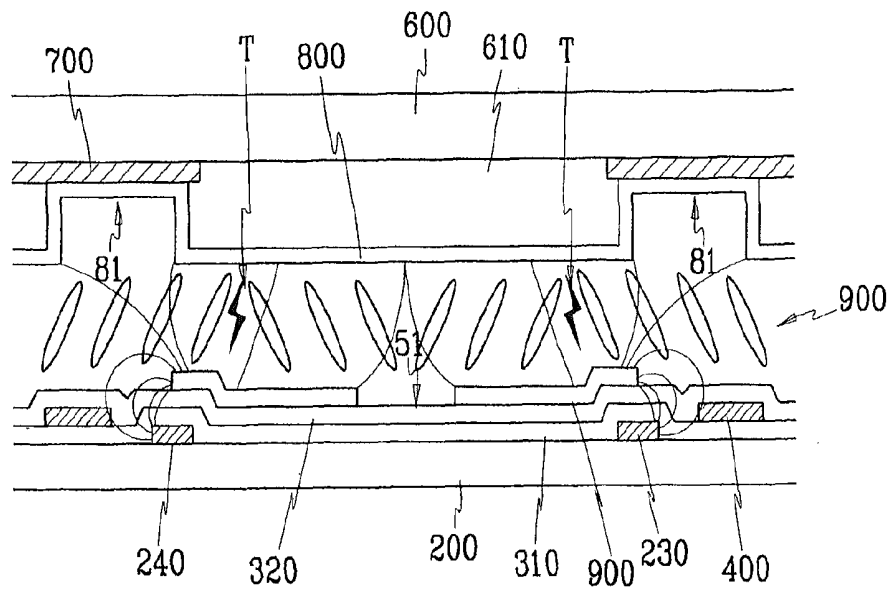
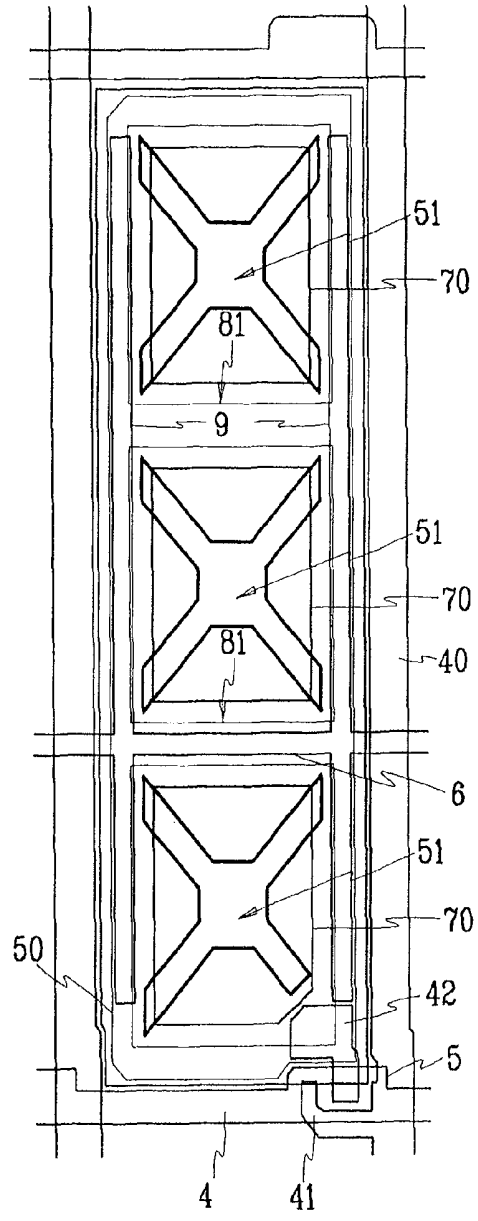
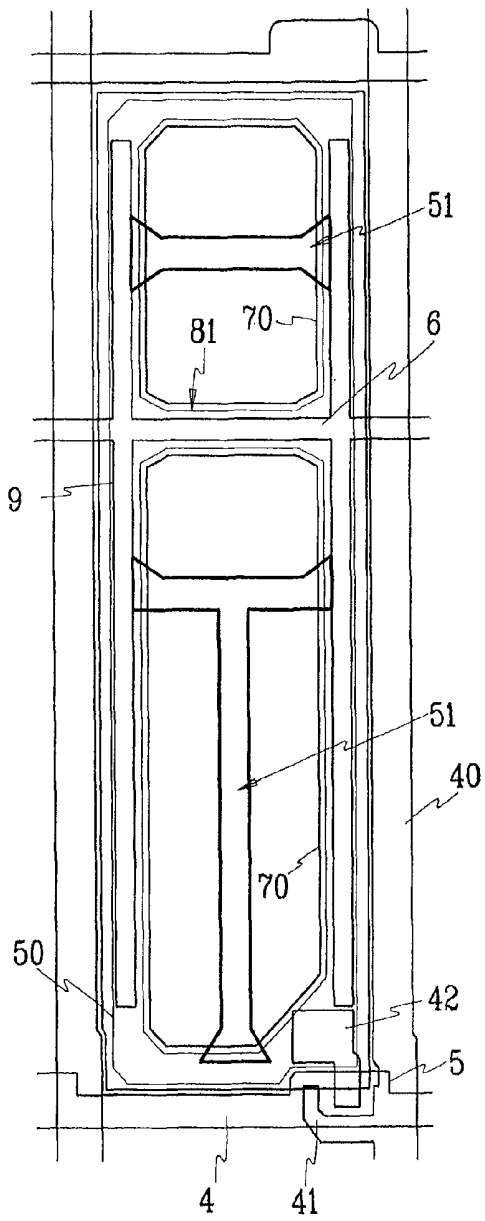

FIG. 13

FIG. 14



LIQUID CRYSTAL DISPLAY HAVING WIDE VIEWING ANGLE

This application is a continuation of co-pending U.S. application Ser. No. 12/483,986 filed on Jun. 12, 2009, which is a continuation of U.S. application Ser. No. 11/172,953 filed on Jul. 5, 2005, and issued as U.S. Pat. No. 7,561,240, which is a continuation of U.S. application Ser. No. 10/454,478 filed on Jun. 5, 2003, and issued as U.S. Pat. No. 6,930,740, which is continuation of U.S. application Ser. No. 09/727,782 filed on Dec. 4, 2000, and issued as U.S. Pat. No. 6,593,982, which is a continuation-in-part of U.S. application Ser. No. 09/431,157 filed on Nov. 1, 1999, and issued as U.S. Pat. No. 6,717,637, which claims priority to and the benefit of Korean Patent Application No. 10-1998-0046153 filed on Oct. 30, 1998, and the benefit of Korean Patent Application No. 10-1999-0054557 filed on Feb. 12, 1999, which are all hereby incorporated by reference for all purposes.

BACKGROUND OF INVENTION

(a) Field of the Invention

The present invention relates to a liquid crystal display and, more particularly, to a liquid crystal display which has a wide viewing angle.

(b) Description of the Related Art

Generally, liquid crystal displays have a structure where a liquid crystal is sandwiched between two substrates, and the electric field applied to the liquid crystal changes its arrangement to control light transmission.

Among them, the vertically aligned twisted nematic (VATN) liquid crystal displays have a pair of internal transparent substrates with transparent electrodes, a liquid crystal sandwiched between the substrates, and two polarizing plates externally attached to the substrates one by one. The liquid crystal molecules are initially aligned perpendicular to the substrates and, under the application of an electric field; they are spirally twisted with a predetermined pitch while being oriented to be parallel to the substrates.

When the polarizing plates are normal to each other in the polarizing direction, light is completely blocked when there is no application of an electric field. That is, in the so-called normally black mode, brightness is very low at an off state and hence the contrast ratio is high compared to the usual TN liquid crystal display. However, under the application of voltage (particularly gray scale voltage), a significant difference is present in retardation of light depending upon the viewing directions as in the usual TN liquid crystal display, so that the viewing angle becomes too narrow.

In order to solve such a problem, it has been proposed that the electrodes be patterned to generate fringe fields, and that the fringe fields generate several micro-regions with different orientation directions of the liquid crystal molecules. For instance, U.S. Pat. No. 5,309,264 issued to Lien discloses a technique of forming X-shaped opening portions at the common electrode. U.S. Pat. No. 5,434,690 issued to Histake et al. discloses a technique of forming opening portions at the electrodes of the top and bottom substrates in an alternate manner.

However, the above techniques require a separate mask to pattern the common electrode. Furthermore, since the color filter pigments may influence the liquid crystal, a protective layer must be formed on the color filters. It also generates serious textures at the periphery of the patterned electrodes.

SUMMARY OF INVENTION

It is an object of the present invention to provide a liquid crystal display which has a wide viewing angle with improved picture quality.

This and other objects may be achieved by a liquid crystal display having a color filter substrate and a thin film transistor array substrate.

The color filter substrate is overlaid with color filters with depression patterns, and a black matrix surrounding the color filters. A common electrode is formed on the color filters with the depression patterns to make partitioned orientations of the liquid crystal molecules.

The black matrix may be overlapped with the depression patterns of the color filters to reduce the light leakage.

The thin film transistor array substrate faces the color filter substrate with pixel electrodes. The pixel electrodes are provided with opening patterns. When the opening patterns of the pixel electrodes, and the depression patterns of the color filters proceed parallel to each in an alternate manner, stable orientations of the liquid crystal molecules and a wide viewing angle can be obtained.

When the common electrode is formed by depositing thin indium tin oxide onto the substrate twice, the common electrode at the periphery of the depression patterns can be prevented from being cut.

Furthermore, the common electrode also has depression patterns corresponding to those of the color filters, with the angle of the side wall of the depression pattern of the common electrode being 30-120 degrees with respect to the thin film transistor array substrate.

Storage capacitor electrodes are further formed at the thin film transistor array substrate. When viewed from the top side, the pixel electrodes completely cover the storage capacitor electrodes at a predetermined region.

BRIEF DESCRIPTION OF THE DRAWINGS

A more complete appreciation of the invention, and many of the attendant advantages thereof, will be readily apparent as the same becomes better understood by reference to the following detailed description when considered in conjunction with the accompanying drawings in which like reference symbols indicate the same or similar components, wherein:

FIGS. 1A and 1B are schematic views illustrating the basic structure of a vertically aligned twisted nematic liquid crystal display according to the present invention in black and white modes;

FIG. 2 is a plan view of a color filter substrate for a liquid crystal display according to a first preferred embodiment of the present invention;

FIG. 3 is a cross sectional view of a color filter substrate taken along the III-III' line of FIG. 2;

FIG. 4 is a cross sectional view of a liquid crystal display with the color filter substrate shown in FIG. 2.

FIG. 5 is a plan view of a liquid crystal display according to a second preferred embodiment of the present invention;

FIG. 6 is a cross sectional view of the liquid crystal display taken along the VI-VI' line of FIG. 5;

FIG. 7 is a plan view of a liquid crystal display according to a third preferred embodiment of the present invention;

FIG. 8 is a cross sectional view of a liquid crystal display according to a fourth preferred embodiment of the present invention;

FIGS. 9A and 9B are amplified views of the liquid crystal display shown in FIG. 8 illustrating equipotential lines and light transmission curves when a side wall of a depression pattern is at an angle of 90 degrees or 45 degrees with respect to a substrate;

FIG. 10 is a plan view of a liquid crystal display according to a fifth preferred embodiment of the present invention;

FIG. 11 is a cross sectional view of the liquid crystal display taken along the XI-XI' line of FIG. 10;

FIG. 12 is a cross sectional view of a liquid crystal display for comparison with the liquid crystal display shown in FIG. 11;

FIG. 13 is a plan view of a liquid crystal display according to a sixth preferred embodiment of the present invention; and

FIG. 14 is a plan view of a liquid crystal display according to a seventh preferred embodiment of the present invention.

DETAILED DESCRIPTION OF THE PREFERRED EMBODIMENTS

Preferred embodiments of this invention will be explained with reference to the accompanying drawings.

FIGS. 1A and 1B schematically illustrate the basic structure of a vertically aligned twisted nematic liquid crystal display according to the present invention when voltage is not applied to liquid crystal molecules and when voltage is applied thereto, respectively.

As shown in the drawings, the liquid crystal display includes two glass or quartz-based substrates 10 and 20 facing each other. Electrodes 11 and 21 based on a transparent conductive material such as indium tin oxide (ITO), and vertical alignment layers 12 and 22 are internally formed on the substrates 10 and 20 in a sequential manner. A liquid crystal layer 100 based on a liquid crystal material having a negative dielectric anisotropy is interposed between the alignment layers 12 and 22. The liquid crystal layer 100 may have chirality, or the alignment layers 12 and 22 may keep the layer 100 twisted. Polarizing plates 13 and 23 are externally attached to the substrates 10 and 20 to polarize the light passing through the liquid crystal layer 100 as well as the light incident upon the liquid crystal layer 100. The polarizing axes of the polarizing plates 13 and 23 are at an angle of 90 degrees to each other.

As shown in FIG. 1A, the long axial directions (the so-called directors) of the liquid crystal molecules 110 are initially aligned to be perpendicular to the substrates 10 and 20 due to the alignment layers 12 and 22. In this state, the light linearly polarized through the polarizing plate 23 attached to the bottom substrate 20 passes through the liquid crystal layer 100 in a direct manner. Then, the light is intercepted by the polarizing plate 13 attached to the top substrate 10 so that the liquid crystal display comes to be in a black state.

When a potential difference is made at the electrodes 11 and 21 under the application of voltage, an electric field is formed such that the direction thereof is perpendicular to the substrate 10 and 20. Accordingly, the orientation directions of the liquid crystal molecules 110 are changed under the influence of the electric field.

As shown in FIG. 1B, when the electric field reaches a predetermined degree due to the large potential difference between the electrodes 11 and 21, the directors of the liquid crystal molecules 110 are oriented to be perpendicular to the direction of the electric field or parallel to the substrates 10 and 20 due to the dielectric anisotropy. But the liquid crystal molecules 110 positioned close to the alignment layers 12 and 22 are kept in the initial state because the alignment force of the alignment layers 12 and 22 exceeds the force of their dielectric anisotropy. Meanwhile, the liquid crystal molecules 110 are spirally twisted due to chirality. When the chirality is controlled in an appropriate manner, the directors of the liquid crystal molecules 110 can be rotated by 90 degrees through the range from the bottom alignment layer 22 to the top alignment layer 12.

The light polarized through the polarizing plate 23 attached to the bottom substrate 20 passes through the liquid crystal layer 100 while being rotated by 90 degrees at the polarizing axis thereof along the twisted directions of the directors, and passes by the polarizing plate 13 attached to the top substrate 10. Therefore, the liquid crystal display comes to be in a white state.

FIG. 2 is a plan view of a color filter substrate for a liquid crystal display according to a first preferred embodiment of the present invention, and FIG. 3 is a cross sectional view of the color filter substrate taken along the III-III' line of FIG. 2.

As shown in the drawings, the color filter substrate 10 is overlaid with a black matrix 14 that defines pixel areas. The black matrix 14 is formed of metal such as chrome, or organic black resist. Color filters 15 of red, green and blue are formed at the pixel areas defined by the black matrix 14. Each color filter 15 has a longitudinal depressed portion 150 centrally proceeding in the vertical direction. A common electrode 11 is formed on the black matrix 14 and the color filters 15 of a transparent conductive material such as ITO.

In the fabrication process, a black matrix is first formed on a substrate through depositing metal such as chrome or black resist thereon, and patterning it.

Thereafter, a resist of red, green or blue is deposited onto the substrate, and patterned to form color filters with depressed portions.

Finally, a transparent conductive material such as ITO is deposited onto the black matrix and the color filters to form a common electrode. Since the common electrode is easily cut and disconnected due to the stepped area on the depressed portion of the color filters, it is preferable to form the common electrode by depositing the conductive material twice, each time with a slight thickness.

The liquid crystal molecules 110 are initially kept perpendicular to the substrates 10 and 20 so that the liquid crystal display is in a black state as with the non-patterned color filters.

When voltage is applied, as shown in FIG. 4, electric fields in most places are perpendicular to the substrates 10 and 20, but the electric field close to the depressed portion 150 of the color filter 15 has curved equipotential lines.

As the liquid crystal has a negative dielectric anisotropy, the orientation directions of the liquid crystal molecules 110 tend to be perpendicular to the direction of the electric field. Therefore, the directors of the liquid crystal molecules close to the depressed portion 150 of the color filter 15 are twisted while being inclined with respect to the substrates 10 and 20. In this way, two micro regions where the inclined directions of the liquid crystal molecules 110 are opposite to each other around the center line of the depressed portion 150 of the color filter 15 are present, and optical characteristics at the two regions compensate for each other, resulting in a wide viewing angle.

The technique of forming depressed portions at the color filters 15 to realize partitioned orientation of the liquid crystal molecules 110 may be easily performed compared to other techniques such as rubbing, and can control the micro-regions very much in detail while varying the shape of the depressed portions.

The depressed portion of the color filter 15 may have a depth identical with the thickness of the color filter 15, or smaller than the thickness of the color filter 15.

FIG. 5 is a plan view of a liquid crystal display according to a second preferred embodiment of the present invention where one pixel area is illustrated, and FIG. 6 is a cross sectional view of the liquid crystal display taken along the VI-VI' line of FIG. 5. In this preferred embodiment, the

depressed patterns of the color filters **15** are exemplified as the opening patterns where the color filters **15** are completely removed. Of course, it is possible that the color filters **15** are only partially removed to form the depressed patterns.

As shown in the drawings, a plurality of linear opening portions are present at one pixel area **300**. That is, first and second linear opening portions **211** and **212** are formed at the color filter **15** of the top substrate **10** while proceeding in the vertical and horizontal directions, and third and fourth linear opening portions **216** and **217** are formed at the electrode **21** of the bottom substrate **20** while proceeding in the vertical and horizontal directions.

The first and second opening portions **211** and **212** formed at the top substrate **10** are separated from each other, and arranged in the vertical direction while roughly forming four squares.

The third opening portion **216** formed at the bottom substrate **20** centrally proceeds at the pixel area **300** in the vertical direction while vertically bisecting the four squares formed by the first and second opening portions **211** and **212**. Both ends of the third opening portion **216** nearly reach the second opening portions **212**. In contrast, the fourth opening portions **217** proceed at the pixel area **300** in the horizontal direction while horizontally bisecting the corresponding square formed by the first and second opening portions **211**. Both ends of the fourth opening portions **217** nearly reach the first opening portions **211**.

Therefore, the opening portions **211**, **212**, **216** and **217** at the two substrates **10** and **20** together form square-shaped micro-regions where the first and second opening portions **211** and **212** form the neighboring sides, and the third and fourth opening portions **216** and **217** form the remaining neighboring sides.

In the above structure, as shown in FIG. 6, the liquid crystal molecules **110** are inclined due to the fringe fields close to the opening portions. The fringe fields close to the first and third opening portions **211** and **216** direct the liquid crystal molecules toward the first opening portions **211** from the third opening portion **216**. Therefore, the orientation directions of the liquid crystal molecules are differentiated while taking the opening portions **211** and **216** as the boundary.

Since the neighboring opening portions defining the square-shaped micro-region are perpendicular to each other, the directors of the liquid crystal molecules within the micro-region vary in position. As indicated by arrows in FIG. 5, the directors of the liquid crystal molecules are directed in four average directions while proceeding toward the angular points of the square-shaped micro-regions from the center thereof.

In this way, sixteen square-shaped micro-regions are formed at one pixel area, and the directors of the liquid crystal molecules within each micro-region are directed in one of the four average directions. The directors of the liquid crystal molecules in the neighboring micro-regions are at an angle of 90 to each other when viewed from the top side.

Furthermore, when the polarizing axes **P1** and **P2** of the polarizing plates are established to be perpendicular to each other in the horizontal and vertical directions, the directors of the liquid crystal molecules within each micro-region are at an angle of 45 degrees with respect to the polarizing axes **P1** and **P2** of the polarizing plates when voltage is applied.

FIG. 7 is a plan view of a liquid crystal display according to a third preferred embodiment of the present invention.

As shown in FIG. 7, a plurality of X-shaped opening portions **400** are formed at each pixel electrode of the bottom substrate while proceeding in the vertical direction, and linear

opening portions **500** are formed at the corresponding color filter while each crosses the center of the X-shaped opening portions **400**.

Of course, the shape of depression patterns including opening patterns formed at the top and bottom substrates may change in various manners.

FIG. 8 is a cross sectional view of a liquid crystal display according to a fourth preferred embodiment of the present invention.

As shown in FIG. 8, the liquid crystal display includes a bottom substrate **1**, a top substrate **60**, and a liquid crystal **90** sandwiched between the bottom and top substrates **1** and **60**. The bottom and top substrates **1** and **60** are formed with a transparent insulating material such as glass.

Pixel electrodes **50** are formed on the bottom substrate **1** with a transparent conductive material such as indium tin oxide (ITO) and indium zinc oxide (IZO) with each having an opening pattern **51**. The pixel electrode **50** is connected to a switching circuit **2** to receive picture image signal voltage. A thin film transistor (TFT) is used as the switching circuit **2**. The TFT is connected to a gate line (not shown) for transmitting scanning signals thereto and a data line (not shown) for transmitting picture image signals thereto. The pixel electrode **50** turns on or off according to the scanning signal. A bottom polarizing plate **3** is externally attached to the bottom substrate **1**. In the case of reflection type liquid crystal displays, the pixel electrode **50** may be formed with a non-transparent material, and the bottom polarizing plate **3** may not be necessary.

The top substrate **60** facing the bottom substrate **1** is sequentially overlaid with a black matrix **70** surrounding color filters **61**, and a common electrode **80**. The common electrode **80** is formed with a transparent conductive material such as ITO or IZO.

Each color filter **61** is provided with a depression pattern, and the common electrode **80** formed on the color filters **61** has depression patterns **81** corresponding to those of the color filters **61**.

The black matrix **70** surrounding the color filters **61** is also formed under the depression patterns **81** of the common electrode **80** to prevent light leakage caused by the depression patterns **81**.

The black matrix **70** is usually formed with a conductive material such as chrome, but may be formed with an organic material. When the black matrix **70** is formed with a conductive material, it also functions as a conduction passage for passing a signal for the common electrode **80**, thereby reducing resistance of the common electrode **80**.

The above structure can have wide viewing angle characteristics for the following reasons.

When voltage is not applied to the display device, the liquid crystal molecules **90** are kept aligned perpendicular to the substrates **1** and **60** while being in a black state, as with the nonpatterned common electrode.

When voltage is applied, as shown in FIG. 8, an electric field is formed normal to the substrates **1** and **60** in most places, but formed in a curved shape along the depression pattern of the common electrode **80**. Therefore, the equipotential lines between the substrates **1** and **60** are not parallel thereto, but curved in accordance with the shape of the common electrode **80**. Consequently, the electric field does not also proceed normal to the substrates **1** and **60**, but is slightly inclined.

As the liquid crystal has a negative dielectric anisotropy, the orientation directions of the liquid crystal molecules tend to be normal to the direction of the electric field. Therefore, the long axes of the liquid crystal molecules close to the

depression pattern **81** are twisted and inclined with respect to the substrates **1** and **60**. In this way, two regions where the inclined directions of the liquid crystal molecules are opposite to each other are divided around the center line of the depression pattern **81** so that the optical characteristics at the two regions compensate for each other, resulting in a wide viewing angle.

The relation between the shape of the depression pattern and the picture quality will be now described.

FIGS. **9A** and **9B** illustrate equipotential lines and light transmission curves where the side wall of the depression pattern is at an angle of 90 degrees or 45 degrees with respect to the substrate.

When the angle between the side wall of the depression pattern and the substrate is 90 degrees, as shown in FIG. **9A**, the equipotential lines are curved a lot at the bottom of the depression pattern of the common electrode **80** and at the top of the opening pattern of the pixel electrode **50**. Since the light transmission varies radically only at the depression pattern and the opening pattern, textures are not shown if the depression pattern is covered. However, when the angle between the side wall of the depression pattern and the opening pattern is 45 degrees, as shown in FIG. **2B**, the equipotential lines become radically curved not only at the bottom of the depression pattern of the common electrode **80** and at the top of the opening pattern of the pixel electrode **50**, but also at the peripheral area of the depression pattern. The light transmission also varies radically at the depression pattern and the opening pattern as well as at the peripheral area of the depression pattern. Therefore, textures are generated at the peripheral area of the depression pattern.

As shown above, the smaller angle between the side wall of the depression pattern and the substrate generates more widely spread textures around the peripheral area of the depression pattern. Therefore, it is preferable that the angle between the side wall of the depression pattern and the substrate becomes great when measured from the side of the color filters **61**. That angle is preferably 90 degrees or more. However, when such an angle is 120 degrees or more, the ITO-based common electrode is easy to be cut and disconnected at the depression pattern.

When the angle between the side wall of the depression pattern and the substrate is 45 degrees, as shown in FIG. **9B**, textures are generated at the peripheral area of the depression pattern. Nevertheless, they do not deteriorate the picture quality in a serious manner. Furthermore, the degree of textures can be controlled through varying the width of the depression pattern or the width of the opening pattern of the pixel electrode. Therefore, the lowest angle between the side wall of the depression pattern and the substrate is about 30 degrees.

FIG. **10** is a plan view of a liquid crystal display according to a fifth preferred embodiment of the present invention, FIG. **11** is a cross sectional view of the liquid crystal display taken along the XI-XI' line of FIG. **10**, and FIG. **12** is a cross sectional view of a liquid crystal display for comparing with the liquid crystal display shown in FIG. **11**.

Gate lines **4** are formed on a bottom insulating substrate **1** with gate electrodes **5** while proceeding in the horizontal direction. Common electrode lines **6** and **7** are formed on the bottom substrate **1** while proceeding parallel to the gate lines **4**. The common electrode lines **6** and **7** are connected to each other via two storage capacitor electrodes **8** and **9** proceeding in the vertical direction. The number of common electrode lines **6** and **7** may be one, three or more. The gate lines **4**, the gate electrodes **5**, the common electrode lines **6** and **7**, and the storage capacitor electrodes **8** and **9** may be formed with a metallic material such as aluminum or chrome while having a

single-layered structure, or a double-layered structure formed sequentially with a chrome-based layer and an aluminum-based layer.

A silicon nitride-based gate insulating layer **31** is formed on the gate lines **4**, the common electrode lines **6** and **7**, and the storage capacitor electrodes **8** and **9**.

Data lines **40** are formed on the gate insulating layer **31** in the vertical direction. Source electrodes **41** are branched from the data lines **40**, and drain electrodes **42** are positioned close to the source electrodes **41** while being separated from them. The data lines **40**, the source electrodes **41**, and the drain electrodes **42** are formed with a metallic material such as chrome or aluminum, in a single or multiple-layered structure.

A semiconductor layer (not shown) for forming TFT channels, and an ohmic contact layer (not shown) for reducing contact resistance between the semiconductor layer and the source and drain electrodes **41** and **42** are formed under the source and drain electrodes **41** and **42**. The semiconductor layer is usually formed with amorphous silicon, and the ohmic contact layer is formed with amorphous silicon doped with n-type impurities of high concentration.

A protective layer **32** is formed on the data lines **40** of an inorganic insulating material such as silicon nitride or an organic insulating material such as resin. The protective layer **32** is provided with contact holes (not shown) opening the drain electrodes **42**.

Pixel electrodes **50** are formed on the protective layer **32** with opening patterns **51**. The pixel electrodes **50** are formed with a transparent conductive material such as indium tin oxide (ITO) or indium zinc oxide (IZO), or an opaque conductive material such as aluminum that exhibits a good light reflection property.

The opening pattern **51** of each pixel electrode **50** has a horizontal opening portion formed at the boundary of the pixel electrode **50** bisecting it into upper and lower regions, and inclined opening portions formed at the upper and lower regions of the pixel electrode **50** while proceeding perpendicular to each other, thereby uniformly distributing fringe fields in all directions.

The storage capacitor electrodes **8** and **9** are completely covered by the pixel electrode **50** at the A, B, C and D regions when viewed from the top side.

A black matrix **70** is formed at the top insulating substrate **60** to prevent leakage of light. Color filters **61** are formed on the top substrate **60** with depression patterns. A common electrode **80** is formed on the color filters **61** with depression patterns **81** corresponding to those of the color filters **61**. The depression patterns **81** of the common electrode **80** are formed due to the corresponding depression patterns of the color filters **61**. The common electrode **80** is formed with a transparent conductive material such as ITO or IZO.

The depression pattern **81** of the common electrode **80** at a pixel area has inclined depressed portions that externally proceed parallel to the upper and lower inclined opening portions of the pixel electrode **50**, and linear depressed portions bent from the inclined depressed portions while being overlapped with the sides of the pixel electrode **50**. The linear depressed portions are classified into horizontal and vertical linear depressed portions. The sides of the pixel electrode **50** overlapping the vertical linear depressed portions completely cover the underlying storage capacitor electrodes **8** and **9**.

In the above-structured liquid crystal display, textures can be effectively prevented in the following respects.

FIG. **12** illustrates a liquid crystal display bearing occurrence of textures. As shown in FIG. **12**, when voltage is applied to a common electrode **800** and a pixel electrode **900**,

a strong electric field is formed between storage capacitor electrodes **230** and **240** and the periphery of the pixel electrode **900**. The strong electric field influences the electric field formed at the periphery of the pixel area. Particularly, such an influence becomes prominent at the A, B, C and D regions where the common electrode **800** is provided with depression patterns **81**. For that reason, the fringe field formed at the periphery of the pixel area is inclined in a direction opposite to the direction of the fringe field formed at the center of the pixel area. Therefore, the orientation directions of the liquid crystal molecules are reverse-turned at the region T between the periphery and the center of the pixel area. Such a region T is displayed on the screen as a texture.

By contrast, in the liquid crystal display shown in FIG. **11**, the pixel electrode **50** completely covers the storage capacitor electrodes **8** and **9**. Therefore, most of the electric lines of force formed between the pixel electrode **50** and the storage capacitor electrodes **8** and **9** are connected to the bottom surface of the pixel electrode **50**. Consequently, the electric field between the pixel electrode **50** and the storage capacitor electrodes **8** and **9** does not influence the liquid crystal molecules. The fringe fields that are not influenced by the storage capacitor electrodes **8** and **9** are kept in the predetermined direction within the pixel area, and varied in direction out of the pixel area (while being covered by the black matrix). As the region T where the orientation directions of the liquid crystal molecules are reverse-turned comes into being out of the pixel area while being covered by the black matrix, textures are not displayed at the screen.

FIG. **13** is a plan view of a liquid crystal display according to a sixth preferred embodiment of the present invention. In this preferred embodiment, other components and structures of the liquid crystal display are the same as those related to the fifth preferred embodiment except that the opening patterns **51** of the pixel electrodes **50**, the depression patterns **81** of the common electrode **80**, the storage capacitor electrodes **9**, and the common electrode lines **6** have a different structure.

The opening pattern **51** of each pixel electrode **50** is formed with horizontal opening portions and vertical opening portions. The depression pattern **81** of the common electrode **80** corresponding to the opening pattern **51** of the pixel electrode is formed with a peripheral depressed portion overlapped with the periphery of the pixel electrode **50**, and a horizontal depressed portion placed between the horizontal opening portions of the pixel electrode **50**.

The opening pattern **51** and the depression pattern **81** are overlapped with each other to thereby divide the pixel area into several micro-regions. Each micro-region is shaped as a polygon having two longer sides that are parallel to each other. Such a structure makes the response speed of the liquid crystal molecules fast. That is, the fringe field formed by the opening pattern **51** and the depression pattern **81** makes the liquid crystal molecules to be oriented parallel to each other. In this way, the liquid crystal molecules moves in one step and reduces the response time.

In the previous fifth preferred embodiment, the micro-regions divided by the opening pattern and the depression pattern are also shaped as a polygon where the two longest sides thereof are parallel to each other.

The common electrode line **6** proceeds in the horizontal direction by one per each pixel area, but may be formed in plurality. The common electrode line **6** is overlapped with the horizontal depressed portion of the depression pattern **81**. The storage capacitor electrode **9** proceeds parallel to the left and right sides of the pixel electrode **50** while being covered by the pixel electrode **50**. This structure is to prevent textures.

FIG. **14** is a plan view of a liquid crystal display according to a seventh preferred embodiment of the present invention. In this preferred embodiment, other components and structures

of the liquid crystal display are the same as those related to the fifth preferred embodiment except that the opening patterns **51** of the pixel electrodes **50**, the depression patterns **81** of the common electrode **80**, the storage capacitor electrodes **9**, and the common electrode lines **6** have a different structure.

The opening pattern **51** of each pixel electrode **50** is formed with a plurality of X-shaped opening portions. The depression pattern **81** is formed with a peripheral depressed portion and horizontal depressed portions while isolating the X-shaped opening portions from each other.

The common electrode line **6** proceeds in the horizontal direction with one for each pixel area, but it may be formed in a plural manner. The common electrode line **6** is overlapped with one of the horizontal depressed portions of the depression pattern **81**. The storage capacitor electrodes **9** proceed parallel to the left and right sides of the pixel electrode **50** while being covered by the pixel electrode **50**.

As described above, the inventive liquid crystal display involves a wide viewing angle, rapid response speed, and excellent picture quality.

While the present invention has been described in detail with reference to the preferred embodiments, those skilled in the art will appreciate that various modifications and substitutions can be made thereto without departing from the spirit and scope of the present invention as set forth in the appended claims.

The invention claimed is:

1. A liquid crystal display (LCD), comprising:

- a first substrate;
 - a second substrate facing the first substrate;
 - a gate line formed on one of the first substrate and the second substrate;
 - a liquid crystal layer disposed between the first substrate and the second substrate;
 - a pixel area disposed on the first substrate and including at least two sub-regions;
 - a first electrode disposed in the pixel area and having at least one cross-shaped first domain divider including a first horizontal portion and a first vertical portion, and
 - a second electrode disposed on the second substrate and having a plurality of second domain dividers arranged in an at least approximately square-shaped pattern including a second horizontal portion and a second vertical portion,
- wherein the first horizontal portion and the second horizontal portion are substantially parallel to the gate line and,
- wherein the first vertical portion and the second vertical portion are substantially parallel to each other and extended substantially perpendicular to the gate line.

2. The LCD of claim 1, wherein the plurality of second domain dividers arranged in an at least approximately square-shaped pattern collectively surround the cross-shaped first domain divider in one of the sub-regions.

3. The LCD of claim 2, wherein each of the sub-regions is divided into four domains by the cross-shaped first domain divider and the second domain dividers are arranged in an at least approximately square-shaped pattern.

4. The LCD of claim 3, wherein the second domain dividers arranged in an at least approximately square-shaped pattern include a first portion disposed between two cross-shaped first domain dividers.

5. The LCD of claim 4, wherein the first portion overlaps the vertical portion of one of the cross-shaped first domain dividers.

- 6. The LCD of claim 1,
wherein each of the sub-regions is divided into four
domains by the cross-shaped first domain divider and the
second domain dividers are arranged in an at least
approximately square-shaped pattern. 5
- 7. The LCD of claim 6,
wherein the second domain dividers arranged in an at least
approximately square-shaped pattern include a first por-
tion disposed between two cross-shaped first domain
dividers. 10
- 8. The LCD of claim 7,
wherein the first portion overlaps the vertical portion of one
of the cross-shaped first domain dividers.
- 9. The LCD of claim 1,
wherein the second domain dividers arranged in an at least 15
approximately square-shaped pattern include a first por-
tion disposed between two cross-shaped first domain
dividers.
- 10. The LCD of claim 9,
wherein the first portion overlaps the vertical portion of one 20
of the cross-shaped first domain dividers.

* * * * *

专利名称(译)	具有宽视角的液晶显示器		
公开(公告)号	US8780305	公开(公告)日	2014-07-15
申请号	US13/865122	申请日	2013-04-17
[标]申请(专利权)人(译)	三星显示有限公司		
申请(专利权)人(译)	三星DISPLAY CO. , LTD.		
当前申请(专利权)人(译)	三星DISPLAY CO. , LTD.		
[标]发明人	YOON YEA SUN PARK SEUNG BEOM NA BYOUNG SUN		
发明人	YOON, YEA-SUN PARK, SEUNG-BEOM NA, BYOUNG-SUN		
IPC分类号	G02F1/1337 G02F1/1333 G02F1/1335 G02F1/1343 G02F1/139		
CPC分类号	G02F1/134309 G02F1/133514 G02F1/133707 G02F1/1393		
优先权	1019980046153 1998-10-30 KR 1019990054557 1999-12-02 KR		
其他公开文献	US20130229611A1		
外部链接	Espacenet USPTO		

摘要(译)

液晶显示器包括具有像素电极的第一基板和具有面向第一基板的公共电极的第二基板。公共电极具有对应于像素电极的凹陷图案。每个凹陷图案的侧壁相对于第一基板成30-120度的角度。通过在滤色器处形成凹陷图案来形成公共电极的凹陷图案。在这种结构中，液晶显示器具有宽视角和良好的图像质量。

