



US 20190243202A1

(19) **United States**

(12) **Patent Application Publication**
YANG et al.

(10) **Pub. No.: US 2019/0243202 A1**

(43) **Pub. Date: Aug. 8, 2019**

(54) **LIQUID CRYSTAL DISPLAY**

Publication Classification

(71) Applicant: **SAMSUNG DISPLAY CO., LTD.**,
Yongin-si (KR)

(51) **Int. Cl.**
G02F 1/1362 (2006.01)
G02F 1/1368 (2006.01)
G09G 3/36 (2006.01)
H01L 33/52 (2006.01)

(72) Inventors: **Yong-Ho YANG**, Suwon-si (KR);
Joo-Sun YOON, Seoul (KR); **Ki-Hun JEONG**, Seoul (KR)

(52) **U.S. Cl.**
CPC **G02F 1/136286** (2013.01); **G02F 1/1368**
(2013.01); **G09G 3/3677** (2013.01); **G09G**
2300/0426 (2013.01); **G09G 2300/0809**
(2013.01); **G09G 2310/0281** (2013.01); **G09G**
2300/0408 (2013.01); **H01L 33/52** (2013.01)

(21) Appl. No.: **16/384,482**

(22) Filed: **Apr. 15, 2019**

Related U.S. Application Data

(60) Continuation of application No. 15/433,880, filed on Feb. 15, 2017, now Pat. No. 10,261,377, which is a continuation of application No. 14/157,338, filed on Jan. 16, 2014, now Pat. No. 9,606,405, which is a continuation of application No. 13/717,445, filed on Dec. 17, 2012, now Pat. No. 8,638,413, which is a division of application No. 11/654,220, filed on Jan. 16, 2007, now Pat. No. 8,334,960.

Foreign Application Priority Data

Jan. 18, 2006 (KR) 10-2006-0005260
Feb. 20, 2006 (KR) 10-2006-0016105

(57) **ABSTRACT**

A liquid crystal display according to an exemplary embodiment of the present invention includes a substrate, a plurality of pixels arranged in a matrix on the substrate where each pixel includes a switching element, a plurality of gate lines that are connected to the switching elements and extend in a row direction, and a gate driver that is connected to the gate lines and is formed on the substrate as an integrated circuit. In the liquid crystal display, the gate driver includes a first region and a second region that is not aligned with the first region.

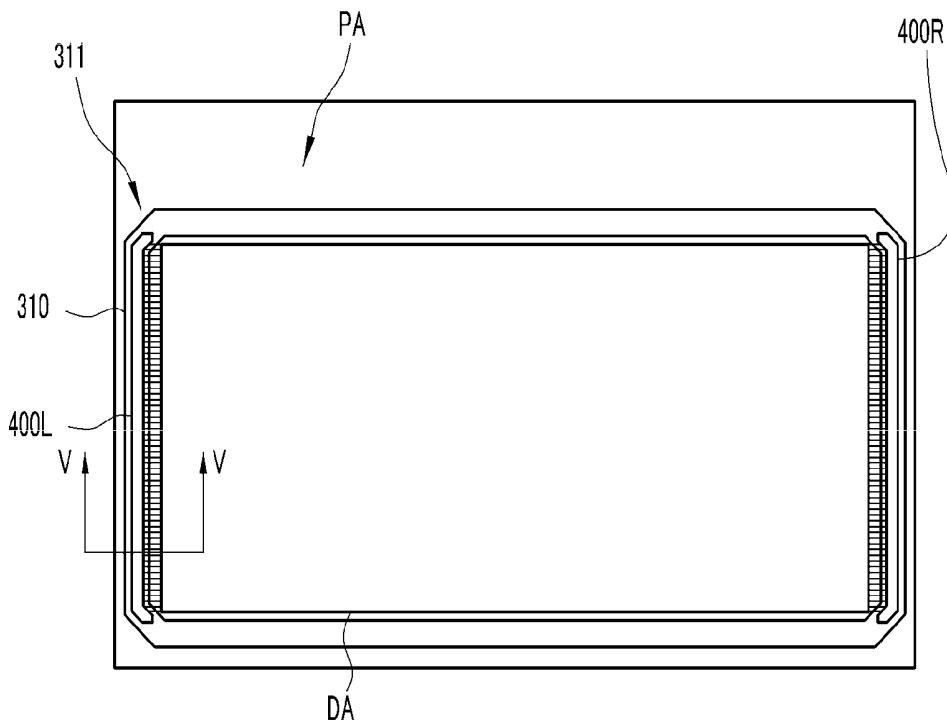

FIG. 1

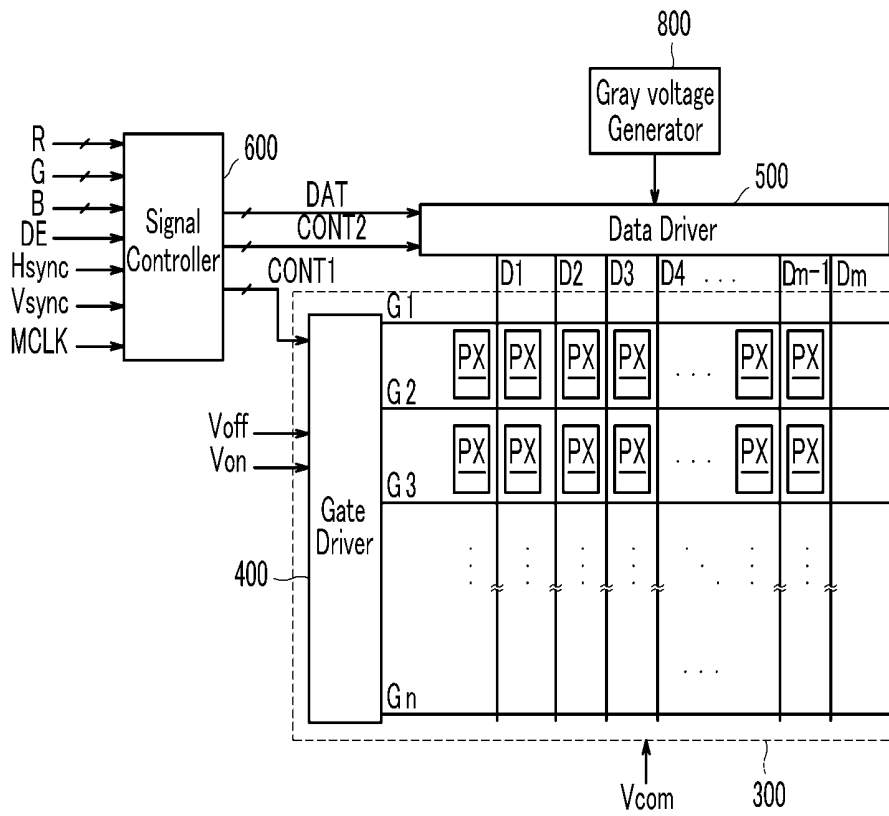

FIG.2

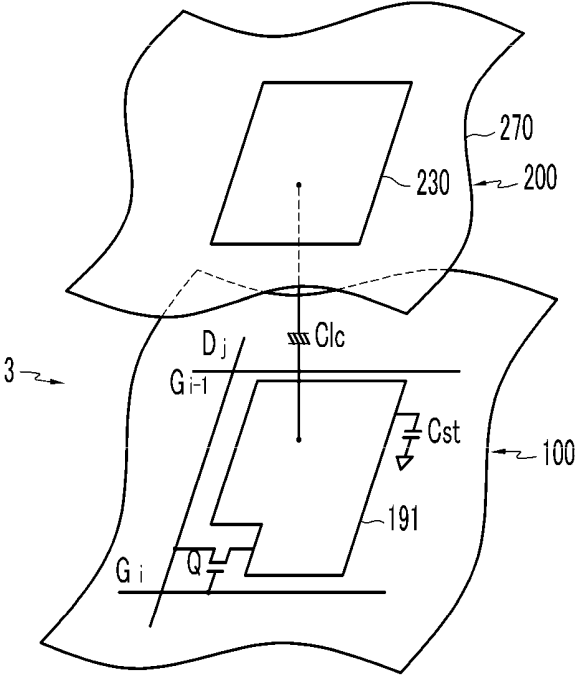

FIG.3

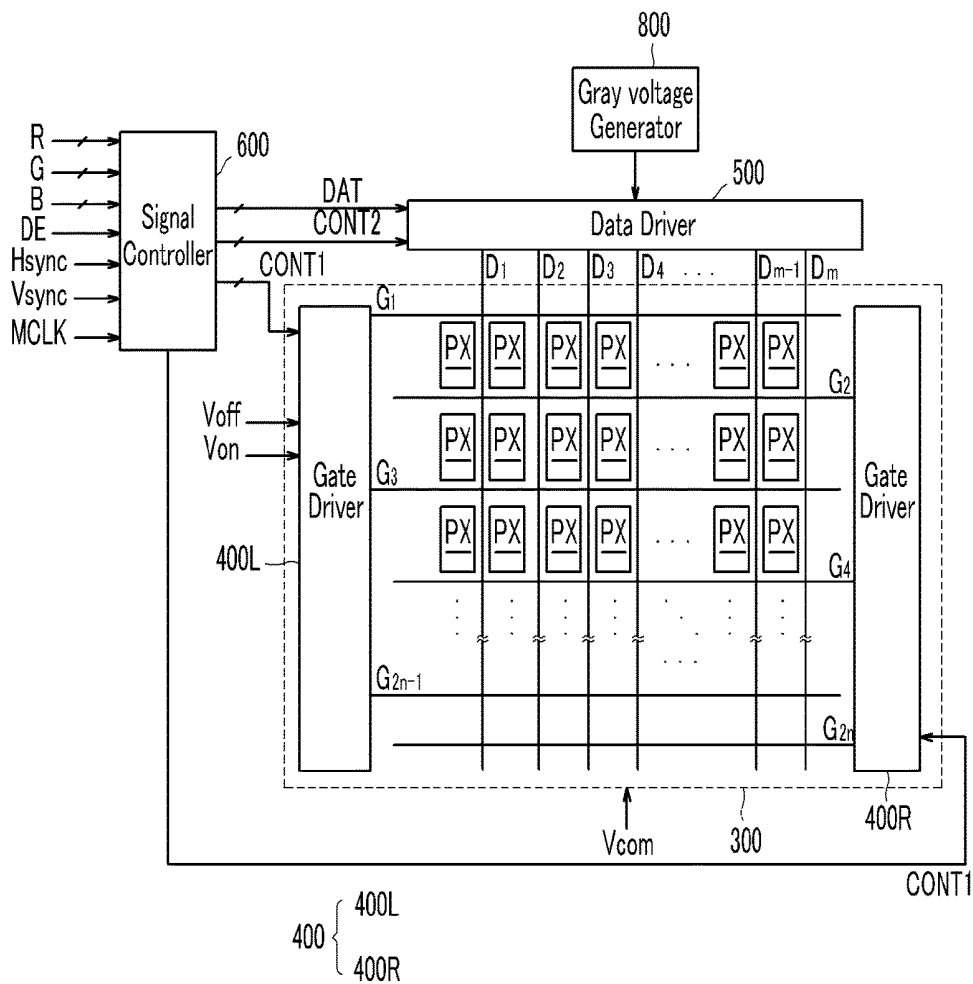

FIG.4

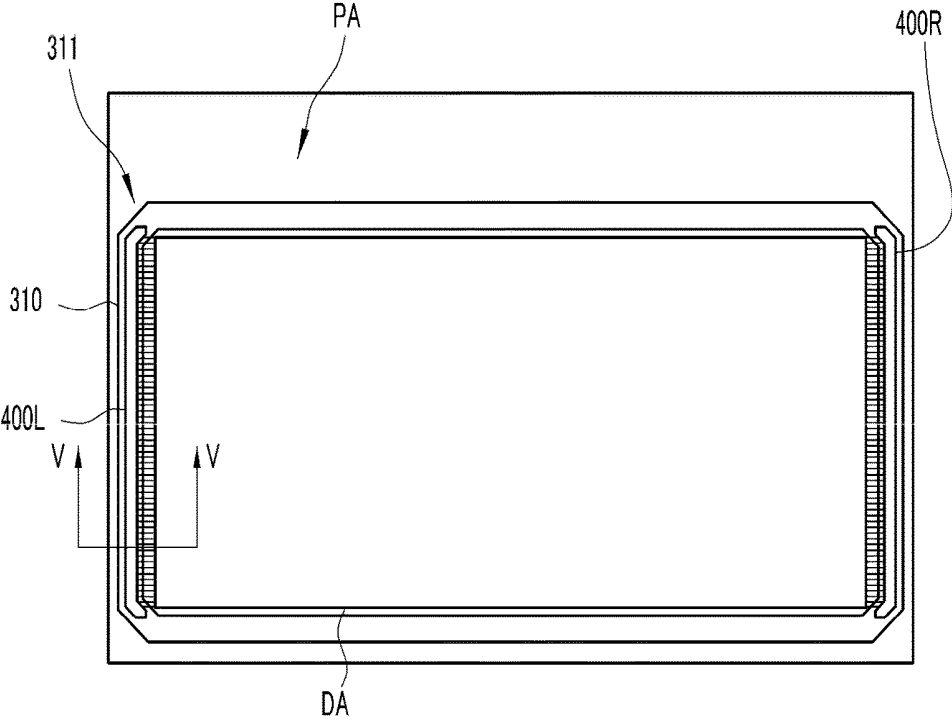

FIG.5

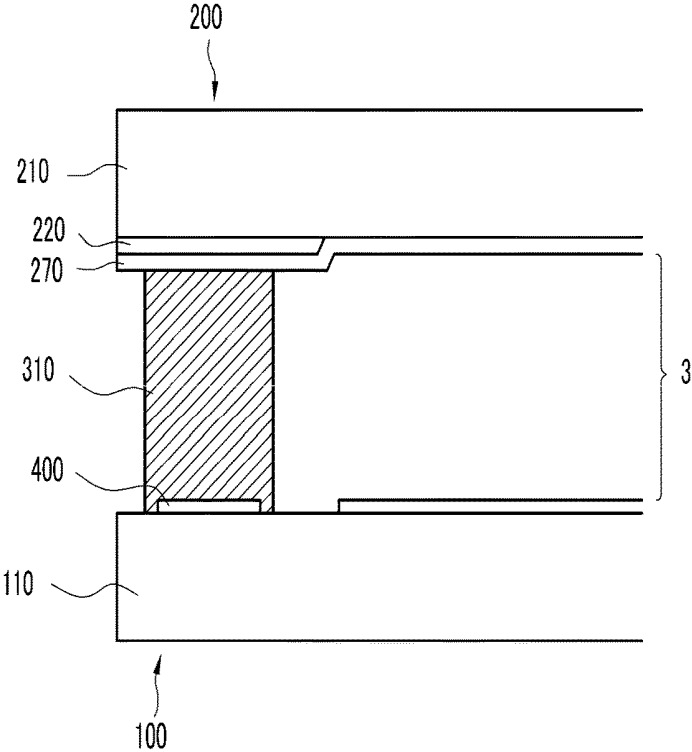

FIG.6

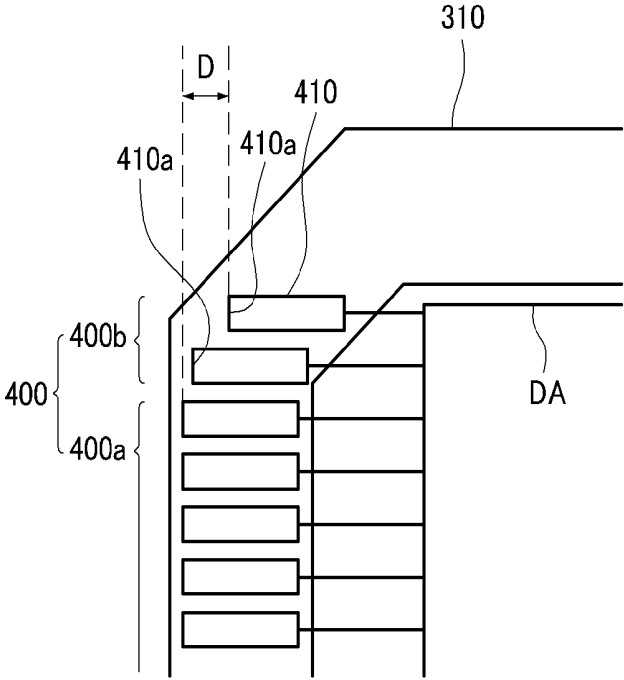

FIG. 7

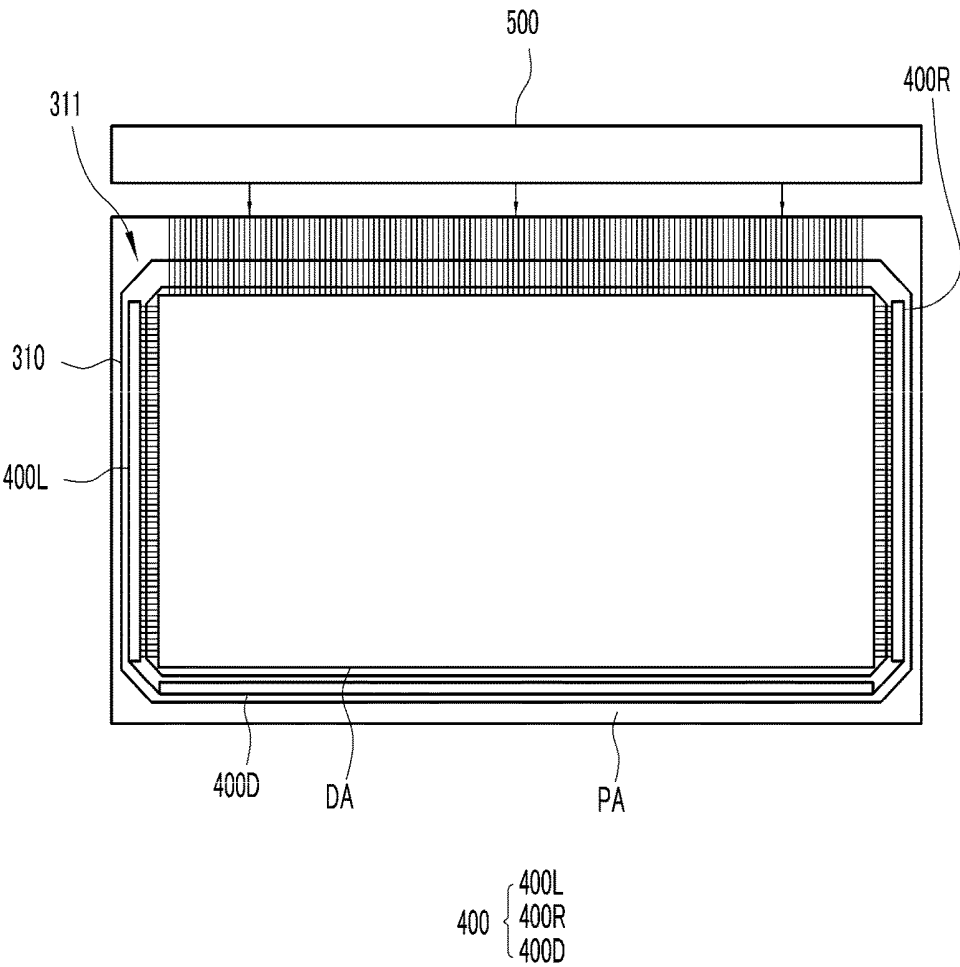
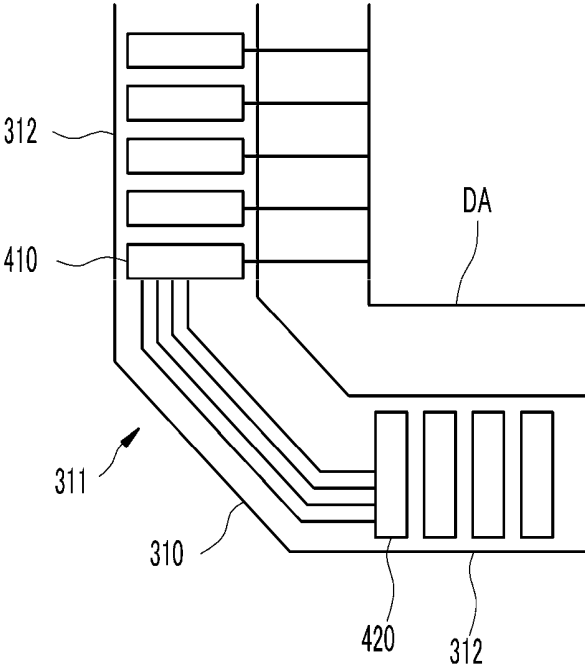

FIG.8



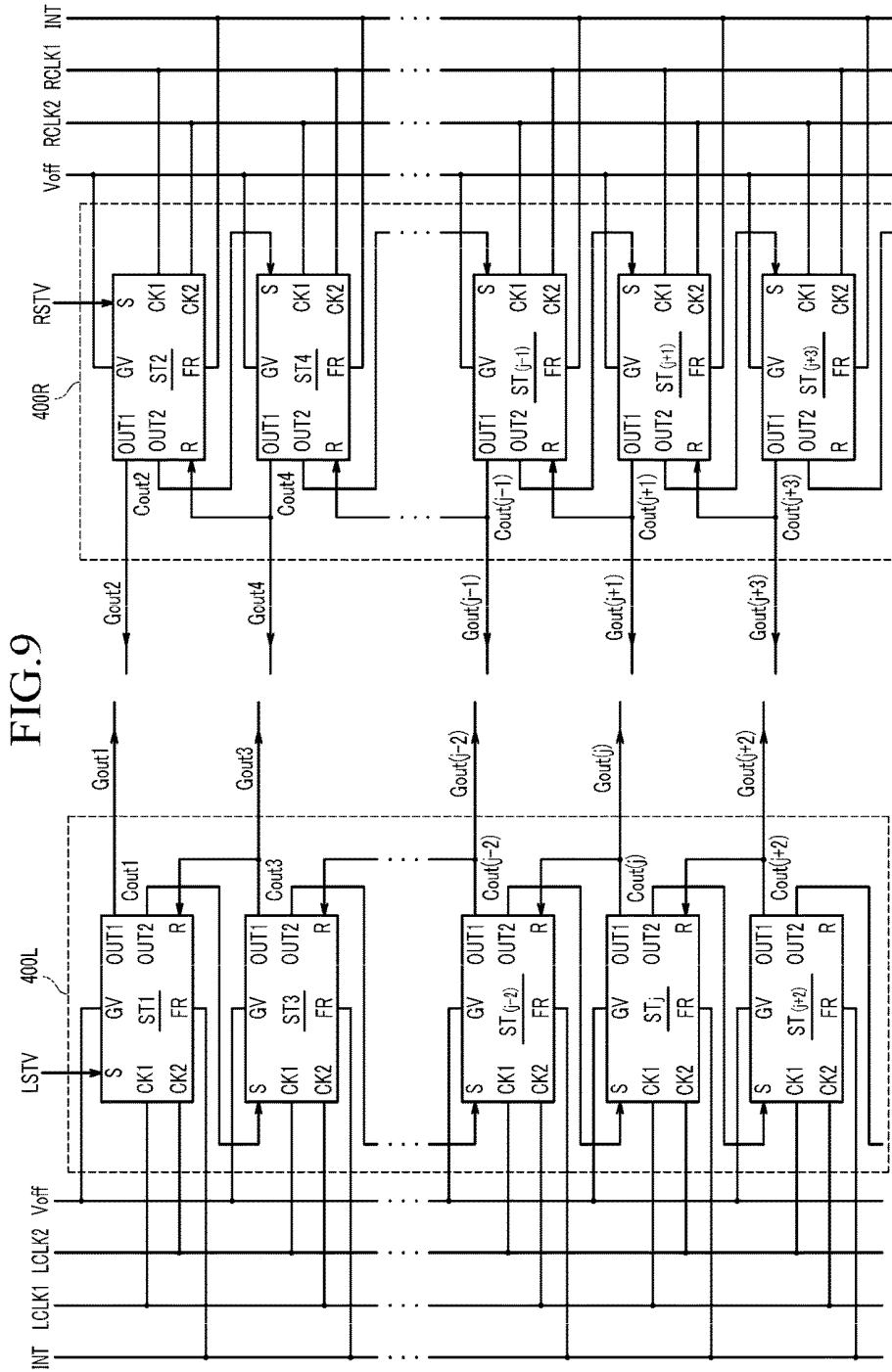

FIG. 10

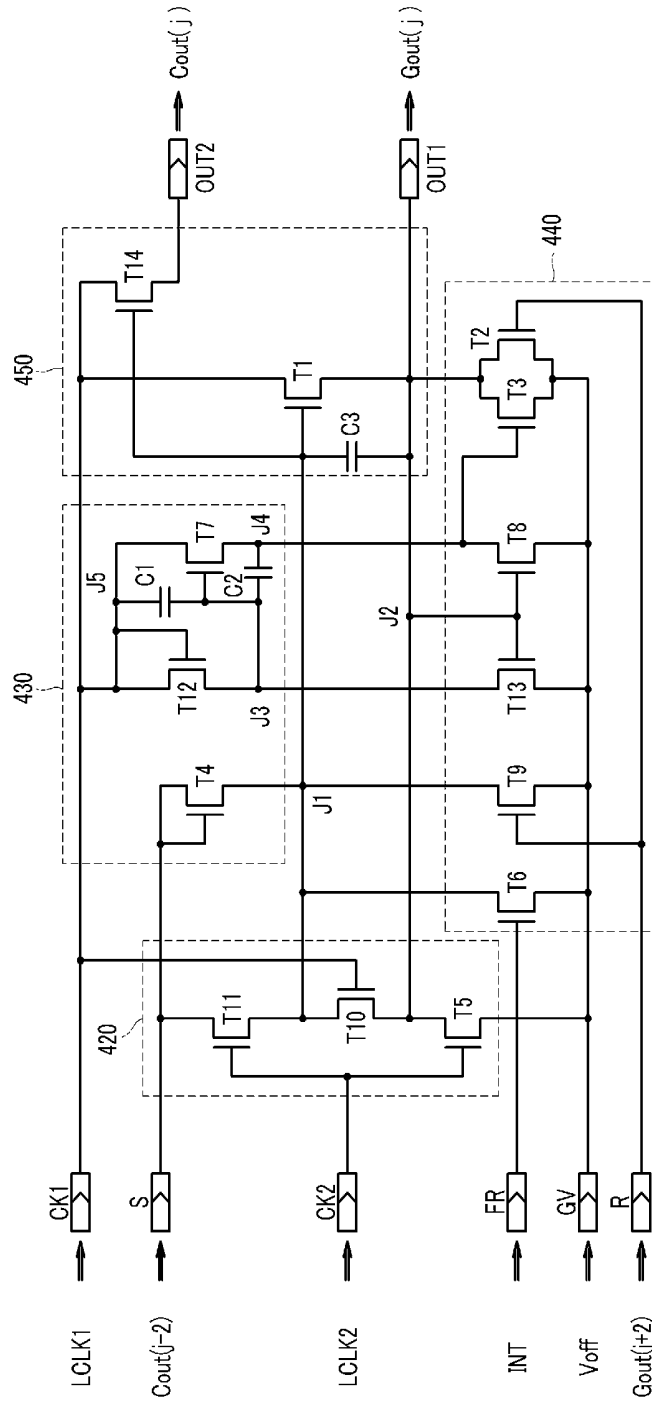

FIG. 11

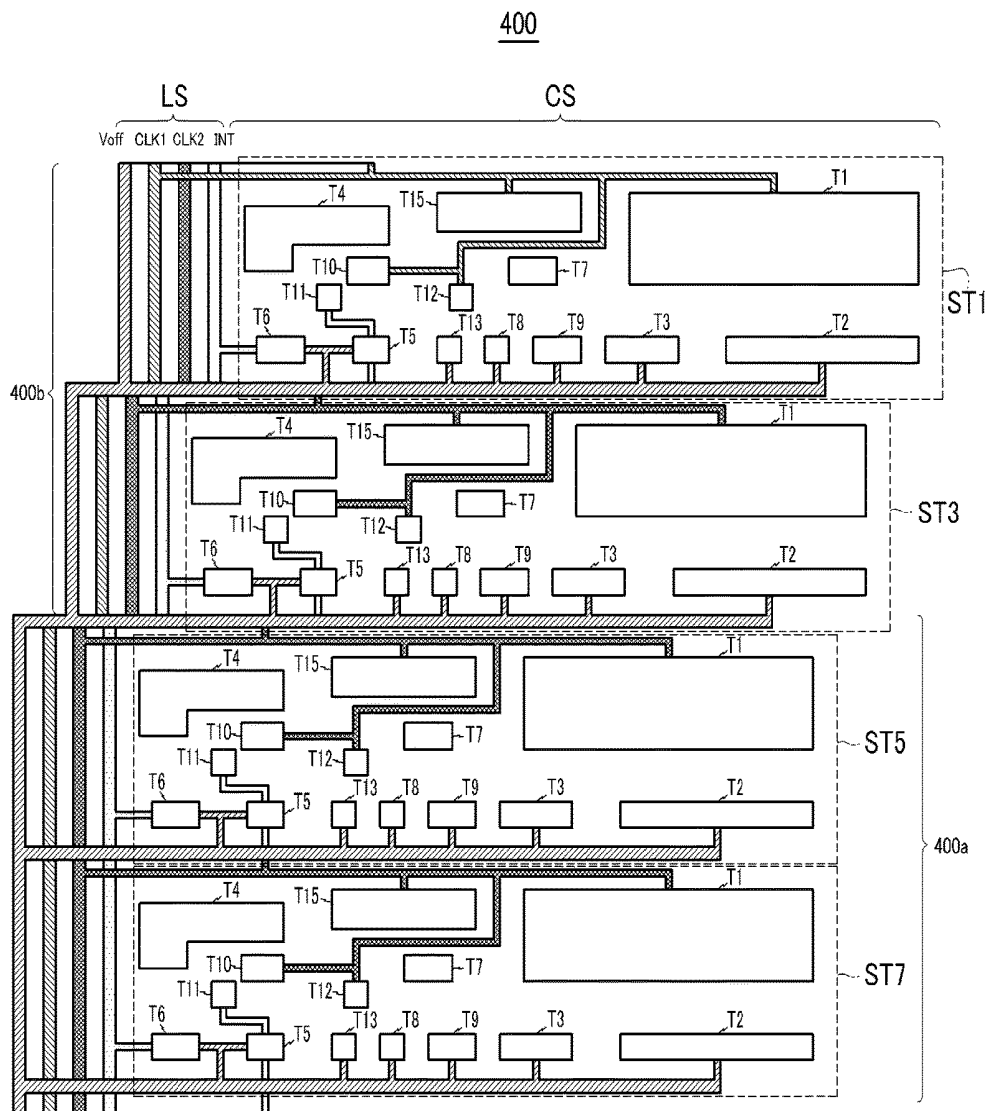
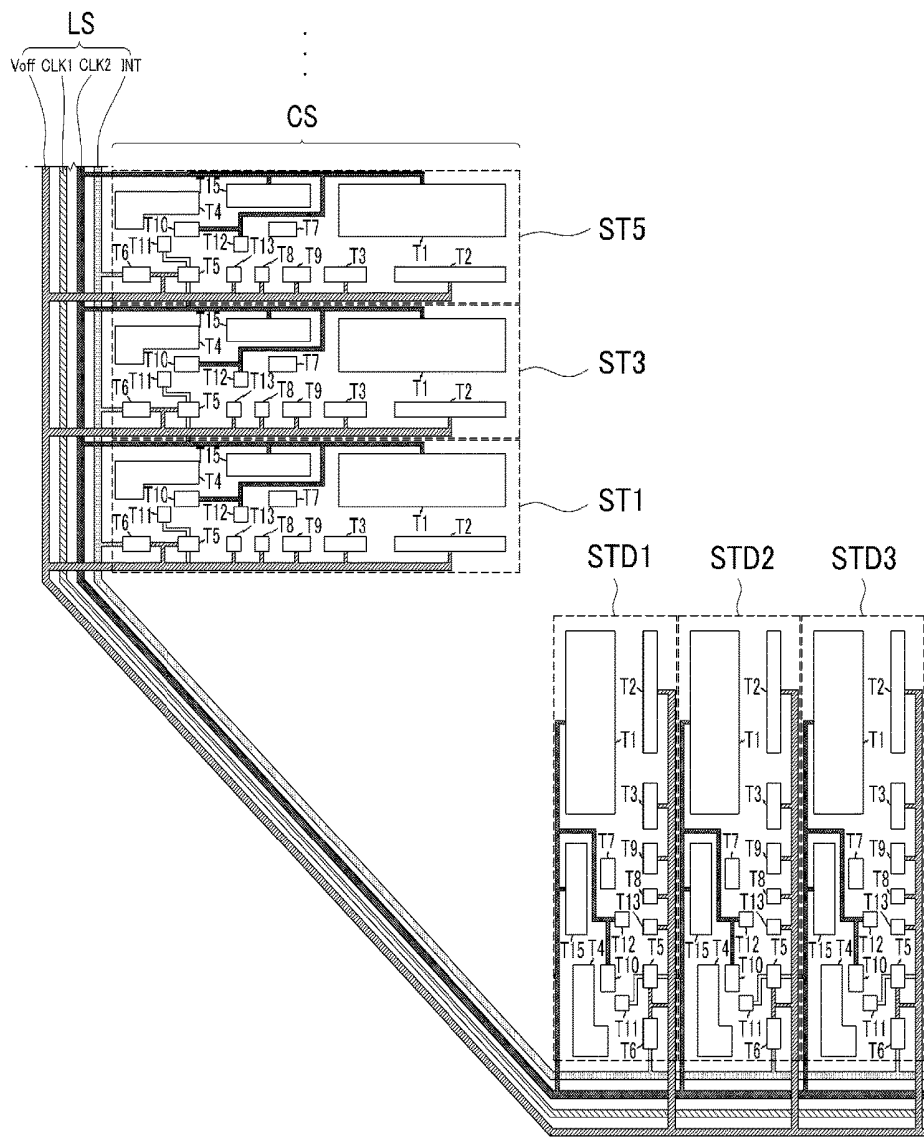

FIG.12

400



LIQUID CRYSTAL DISPLAY

CROSS-REFERENCE TO RELATED APPLICATIONS

[0001] This application is a continuation application of U.S. patent application Ser. No. 15/433,880, filed on Feb. 15, 2017, which is continuation application of U.S. patent application Ser. No. 14/157,338, filed on Jan. 16, 2014, which is a continuation application of U.S. patent application Ser. No. 13/717,445, filed on Dec. 17, 2012, which is a divisional application of U.S. patent application Ser. No. 11/654,220, filed on Jan. 16, 2007, which claims priority to and the benefit of Patent Application Nos. 10-2006-0005260 and 10-2006-0016105 that were respectively filed in the Korean Intellectual Property Office, Republic of Korea, on Jan. 18, 2006, and Feb. 20, 2006, the entire contents of which are incorporated by reference.

BACKGROUND OF THE INVENTION

(a) Field of the Invention

[0002] The present invention relates to display devices, and more particularly to a liquid crystal display.

(b) Description of the Related Art

[0003] A liquid crystal display is one type of flat panel display that has come into widespread use in recent years. Liquid crystal displays typically include two display panels on which electric field generating electrodes, such as pixel electrodes and a common electrode, are formed, with a liquid crystal layer interposed therebetween. In the liquid crystal display, when a voltage is applied to the electric field generating electrodes, an electric field is generated in the liquid crystal layer. The orientation of liquid crystal molecules within the liquid crystal layer is determined and the polarization of incident light is controlled by the electric field, thereby displaying a desired image.

[0004] Liquid crystal displays typically include switching elements connected to the pixel electrodes and a plurality of signal lines, such as gate lines and data lines, for controlling the switching elements to apply a voltage to the pixel electrodes. The gate lines transmit gate signals generated by a gate driving circuit, and the data lines transmit a data voltage generated by a data driving circuit. In addition, the switching elements transmit the data voltage to the pixel electrodes on the basis of the gate signals. The gate driver and the data driver may be mounted to the display panel in the form of a chip. However, in recent years, the gate driver has been integrated into the display panel in order to reduce the overall size of a display device and to improve the productivity thereof.

[0005] The above information disclosed in this Background section is only for enhancement of understanding of the background of the invention and therefore it may contain information that does not form the prior art that is already known in this country to a person of ordinary skill in the art.

SUMMARY OF THE INVENTION

[0006] Embodiments of the present invention address the need for a liquid crystal display capable of effectively protecting an integrated display panel gate driver from the external environment. According to an exemplary embodiment of the present invention, a liquid crystal display

includes a substrate, a plurality of pixels arranged in a matrix on the substrate where each pixel includes a switching element, a plurality of gate lines that are connected to the switching elements and extend in a row direction, and a gate driver that is connected to the gate lines and is formed on the substrate as an integrated circuit. In the liquid crystal display, the gate driver includes a first region and a second region that is not aligned with the first region.

[0007] In the above-mentioned embodiment, the second region may include a third region and a fourth region arranged at both sides of the first region. A first distance between the first region and the pixels may be greater than a second distance between the second region and the pixels. The gate driver may include a first gate driver that is connected to odd-numbered gate lines among the gate lines and a second gate driver that is connected to even-numbered gate lines among the gate lines. The first gate driver and the second gate driver may be disposed opposite to each other with the pixels interposed therebetween.

[0008] In the above-mentioned embodiment, the gate driver may include a plurality of circuit portions connected to the gate lines and a plurality of wiring portions that are connected to the circuit portions where each of the wiring portions has a plurality of wiring lines for transmitting signals. At least two of the plurality of circuit portions may be arranged in a line, and at least another one of the plurality of circuit portions may not be aligned with the at least two of the plurality of circuit portions arranged in a line. The wiring lines may be bent in the first and second regions. The embodiment may further include a sealant that is formed so as to surround the pixels. The sealant may cover the gate driver. The sealant may cover all the wiring lines of the gate driver. A distance between the wiring portion of the first region and the wiring portion of the second region may be smaller than 300 μm (micrometers).

[0009] According to another exemplary embodiment of the present invention, a liquid crystal display includes a substrate, a plurality of pixels arranged in a matrix on the substrate where each pixel includes a switching element, a plurality of gate lines that are connected to the switching elements and extend in a row direction, a gate driver that is connected to the gate lines and is formed on the substrate as an integrated circuit, and a sealant that covers the gate driver. In the liquid crystal display, the gate driver includes a first region and a second region that is not aligned with the first region.

[0010] According to still another exemplary embodiment of the present invention, a liquid crystal display includes a substrate, a display area in which a plurality of pixels arranged in a matrix on the substrate where each pixel includes a switching element, a plurality of gate lines that are connected to the switching elements and extend in a row direction, a sealant that is formed so as to surround the plurality of pixels and includes at least one edge portion, and a gate driver that is formed on the substrate as an integrated circuit and is covered with the sealant. In the liquid crystal display, the gate driver is formed in portions other than the edge portion of the sealant.

[0011] In the above-mentioned embodiment, the gate driver may include a plurality of main gate driving circuits that transmit gate signals to the gate lines, and a plurality of sub gate driving circuits that assist the operation of the main gate driving circuits. The main gate driving circuits may be positioned at a side of the display area, and the sub gate

driving circuits may be positioned at one of an upper or lower side of the display area. The main gate driving circuits and the sub gate driving circuits may include circuit portions connected to the gate lines and wiring portions connected to the circuit portions respectively, where the wiring portion of the main gate driving circuits may be connected to the wiring portion of the sub gate driving circuits. The main gate driving circuits may include a first portion connected to an odd-numbered gate line among the gate lines and a second portion connected to an even-numbered gate line among the gate lines. The first portion and the second portion may be disposed opposite to each other with the display area interposed therebetween.

[0012] The scope of the invention is defined by the claims, which are incorporated into this section by reference. A more complete understanding of embodiments of the invention will be afforded to those skilled in the art, as well as a realization of additional advantages thereof, by a consideration of the following detailed description. Reference will be made to the appended sheets of drawings that will first be described briefly.

BRIEF DESCRIPTION OF THE DRAWINGS

[0013] FIG. 1 is a block diagram illustrating a liquid crystal display according to an exemplary embodiment of the present invention.

[0014] FIG. 2 is an equivalent circuit diagram illustrating one pixel of a liquid crystal display according to an exemplary embodiment of the present invention.

[0015] FIG. 3 is a block diagram illustrating a liquid crystal display according to another exemplary embodiment of the present invention.

[0016] FIG. 4 is a plan view illustrating a liquid crystal panel assembly according to an exemplary embodiment of the present invention.

[0017] FIG. 5 is a cross-sectional view of the liquid crystal panel assembly shown in FIG. 4 taken along the line V-V.

[0018] FIG. 6 is a plan view illustrating in detail a portion of the liquid crystal panel assembly shown in FIG. 4.

[0019] FIG. 7 is a plan view illustrating a liquid crystal panel assembly according to another exemplary embodiment of the present invention.

[0020] FIG. 8 is a plan view illustrating in detail the liquid crystal panel assembly shown in FIG. 7.

[0021] FIG. 9 is a block diagram illustrating a gate driver according to an exemplary embodiment of the present invention.

[0022] FIG. 10 is a circuit diagram illustrating a j-th stage of a shift register for a gate driver shown in FIG. 7.

[0023] FIG. 11 is a layout view schematically illustrating a gate driver shown in FIG. 4.

[0024] FIG. 12 is a layout view schematically illustrating a gate driver shown in FIG. 7.

DETAILED DESCRIPTION OF THE EMBODIMENTS

[0025] Embodiments of the present invention will now be described more fully hereinafter with reference to the accompanying drawings, in which preferred embodiments of the invention are shown. As those skilled in the art would realize, the described embodiments may be modified in various ways, all without departing from the spirit or scope of the present invention. In the drawings, the thickness of

layers, films, panels, regions, etc., may be exaggerated for clarity. Like reference numerals designate like elements throughout the specification. It will be understood that when an element such as a layer, film, region, or substrate is referred to as being “on” another element, it can be directly on the other element or intervening elements may also be present. In contrast, when an element is referred to as being “directly on” another element, there are no intervening elements present.

[0026] First, a liquid crystal display according to an exemplary embodiment of the present invention will be described below with reference to FIGS. 1 and 2. The term exemplary herein describes an example embodiment and not necessarily an ideal embodiment. FIG. 1 is a block diagram illustrating a liquid crystal display according to an exemplary embodiment of the present invention, and FIG. 2 is an equivalent circuit diagram illustrating a pixel of the liquid crystal display according to the exemplary embodiment of the present invention. As shown in FIGS. 1 and 2, the liquid crystal display according to the exemplary embodiment of the present invention includes a liquid crystal panel assembly 300, a pair of a gate driver 400 and a data driver 500 connected to the liquid crystal panel assembly 300, a gray voltage generator 800 connected to the data driver 500, and a signal controller 600 for controlling the above elements.

[0027] In the equivalent circuit diagram, the liquid crystal panel assembly 300 includes a plurality of signal lines G_1 to G_n and D_1 to D_m and a plurality of pixels PX that are connected to the plurality of signal lines and are substantially arranged in a matrix configuration. As shown in FIG. 2, the liquid crystal panel assembly 300 includes lower and upper panels 100 and 200 facing each other and a liquid crystal layer 3 interposed therebetween. The signal lines include a plurality of gate lines G_1 to G_n for transmitting gate signals (also referred to as “scanning signals”) and a plurality of data lines D_1 to D_m for transmitting data signals. The gate lines G_1 to G_n extend substantially in a row direction and are substantially parallel to each other, while the data lines D_1 to D_m extend substantially in a column direction and also are substantially parallel to each other. Each pixel PX includes a switching element Q connected to one of the signal lines, a liquid crystal capacitor Clc connected to the switching element Q, and a storage capacitor Cst. The storage capacitor Cst may be omitted. The switching element Q is a three-terminal element, such as a thin film transistor, and is disposed on the lower panel 100. A control terminal of the switching element Q is connected to a gate line G_j , an input terminal thereof is connected to a data line D_j , and an output terminal thereof is connected to the liquid crystal capacitor Clc and the storage capacitor Cst.

[0028] The liquid crystal capacitor Clc has as two terminals a pixel electrode 191 of the lower panel 100 and a common electrode 270 of the upper panel 200, and also has the liquid crystal layer 3 between the two electrodes 191 and 270 as a dielectric material. The pixel electrode 191 is connected to the switching element Q, and the common electrode 270 covers an entire surface of the upper panel 200 and is supplied with a common voltage Vcom. Unlike the structure shown in FIG. 2, the common electrode 270 may be provided on the lower panel 100. In this case, at least one of the two electrodes 191 and 270 may have a shape of bar or stripe. The storage capacitor Cst, serving as an auxiliary capacitor of the liquid crystal capacitor Clc, is composed of a signal line (not shown) provided on the lower panel 100,

the pixel electrode **191**, and an insulator interposed therebetween. A predetermined voltage, such as a common voltage V_{com} , is applied to the signal line. Alternatively, the storage capacitor C_{st} may be a laminated structure of the pixel electrode **191**, the insulator, and a previous gate line formed on the insulator.

[0029] Meanwhile, in order to perform color display, each pixel PX specifically displays one primary color (spatial division), or the pixels PX alternately display the primary colors over time (temporal division), which causes the primary colors to be spatially or temporally synthesized, thereby displaying a desired color. An example of a set of the primary colors may be composed of, for example, red, green, and blue. As an example of the spatial division, FIG. 2 shows that each pixel PX has a color filter **230** for displaying one of the primary colors in a region of the upper panel **200** corresponding to the pixel electrode **191**. Alternatively, the structure shown in FIG. 2, the color filter **230** may be provided on or under the pixel electrode **191** of the lower panel **100**. One or more polarizers (not shown) for polarizing light are attached to the outer surface of the liquid crystal panel assembly **300**.

[0030] Referring to FIG. 1 again, the gray voltage generator **800** generates a full number of gray voltages or a limited number of gray voltages (referred to as "reference gray voltages" hereinafter) related to the transmittance of the pixels PX. Some of the (reference) gray voltages have a positive polarity relative to the common voltage V_{com} , while the other of the (reference) gray voltages have a negative polarity relative to the common voltage V_{com} . The gate driver **400** is connected to the gate lines G_1 to G_n of the liquid crystal panel assembly **300**, and synthesizes a gate-on voltage V_{on} and a gate-off voltage V_{off} to generate the gate signals for application to the gate lines G_1 - G_n . The gate driver **400** substantially serves as a shift register, and includes a plurality of stages arranged in a line. The gate driver **400** is formed and integrated into the liquid crystal panel assembly **300** together with the signal lines G_1 to G_n and D_1 to D_m and the thin film transistor switching elements Q by the same process. The data driver **500** is connected to the data lines D_1 to D_m of the liquid crystal panel assembly **300**, selects the gray voltage generated by the gray voltage generator **800**, and supplies the selected gray voltage to the data lines D_1 to D_m as a data signal. However, when the gray voltage generator **800** generates only a reduced number of the reference gray voltages instead of all the gray voltages, the data driver **500** may divide the reference gray voltages to generate the data voltages among the gray voltages. The signal controller **600** controls, for example, the gate driver **400** and the data driver **500**.

[0031] Each of the drivers **500**, **600**, and **800** may be directly mounted on the liquid crystal panel assembly **300** in the form of at least one IC chip, may be mounted on a flexible printed circuit film (not shown) and then mounted on the liquid crystal panel assembly **300** in the form of a tape carrier package (TCP), or may be mounted on a separate printed circuit board (not shown). Alternatively, the drivers **500**, **600**, and **800** may be integrated with the liquid crystal panel assembly **300** together with, for example, the signal lines G_1 to G_n and D_1 to D_m and the thin film transistor switching elements Q. The drivers **500**, **600**, and **800** may be integrated into a single chip. In this case, at least one of the drivers or at least one circuit forming the drivers may be arranged outside the single chip.

[0032] Next, a liquid crystal display according to another exemplary embodiment of the present invention will be described with reference to FIG. 3. FIG. 3 is a block diagram illustrating a liquid crystal display according to another exemplary embodiment of the present invention. Referring to FIG. 3, the liquid crystal display according to the present exemplary embodiment includes a liquid crystal panel assembly **300**, a gate driver **400** and a data driver **500** connected to the liquid crystal panel assembly **300**, a gray voltage generator **800** connected to the data driver **500**, and a signal controller **600** for controlling these components.

[0033] The liquid crystal display shown in FIG. 3 differs from the liquid crystal display shown in FIG. 1 in that a pair of gate lines G_1 to G_{2n} is arranged for each row of pixels. The gate driver **400** is divided into first and second gate drivers **400L** and **400R** disposed on the left and right sides of the liquid crystal panel **300**. The first gate driver **400L** is connected to odd-numbered gate lines $G_1, G_3, \dots, G_{2n-1}$, and the second gate driver **400R** is connected to even-numbered gate lines G_2, G_4, \dots, G_{2n} . However, this is not considered limiting. For example, odd-numbered gate lines $G_1, G_3, \dots, G_{2n-1}$ may be connected to the second gate driver **400R**, and even-numbered gate lines G_2, G_4, \dots, G_{2n} may be connected to the first gate driver **400L**. The first and second gate drivers **400L** and **400R** are connected to the gate lines G_1 to G_{2n} of the liquid crystal panel assembly **300**, and supply gate signals, each synthesizes a gate-on voltage V_{on} and a gate-off voltage V_{off} to generate the gate signals for application to the gate lines G_1 - G_{2n} . In this way, it is possible to supply the gate signals to the gate lines G_1 to G_{2n} from both sides of the liquid crystal panel assembly **300**, which prevents the gate signals from being delayed at one side of each of the gate lines G_1 to G_{2n} . Therefore, it is possible to effectively transmit the gate signals through all the gate lines G_1 to G_{2n} .

[0034] Next, the operation of the liquid crystal display will be described in detail below. The signal controller **600** is supplied with input image signals R, G, and B and input control signals for displaying the input image signals from an external graphic controller (not shown). The input image signals R, G and B contain luminance information of pixels PX where the luminance has a predetermined number of grays or gray levels, for example, $1024(=2^{10})$, $256(=2^8)$, or $64(=2^6)$ grays. The input control signals include a vertical synchronization signal V_{sync} , a horizontal synchronization signal H_{sync} , a main clock signal MCLK, and a data enable signal DE.

[0035] The signal controller **600** processes the input image signals R, G, and B so as to be suitable for the operational conditions of the liquid crystal panel assembly **300** on the basis of the input control signal, and generates, for example, a gate control signal CONT1 and a data control signal CONT2. Then, the signal controller **600** transmits the gate control signal CONT1 to the gate driver **400** and transmits the data control signal CONT2 and the processed image signal DAT to the data driver **500**. The gate control signal CONT1 includes a scanning start signal STV for instructing to start scanning and at least one clock signal for controlling the output cycle of the gate-on voltage V_{on} . The gate control signal CONT1 may further include an output enable signal OE for defining the duration of the gate-on voltage V_{on} . The data control signal CONT2 includes a horizontal synchronization start signal STH for informing of start of data transmission for a row (group) of pixels PX starts, a load

signal LOAD for instructing to apply the data voltages to the data lines D_1 to D_m , and a data clock signal HCLK. The data control signal CONT2 may further include an inversion signal RVS for reversing the polarity of the voltage of a data signal with respect to the common voltage Vcom (hereinafter, “the polarity of the voltage of a data signal with the common voltage” is simply referred to as “the polarity of a data signal”).

[0036] The data driver 500 receives the digital image signal DAT for a row (group) of pixels PX in response to the data control signal CONT2 transmitted from the signal controller 600, selects a gray voltage corresponding to each digital image signal DAT, converts the digital image signal DAT into an analog data signal, and supplies the analog data signal to the corresponding data lines D_1 to D_m . The gate driver 400 applies the gate-on voltage Von to the gate lines G_1 to G_n , in response to the gate control signal CONT1 from the signal controller 600 to turn on the switching elements Q connected to the gate lines G_1 to G_n . Then, the data signals applied to the data lines D_1 to D_m are supplied to the corresponding pixels PX through the switching elements Q that are in an on state. The difference between the voltage of the data signal applied to the pixel PX and the common voltage Vcom is a charging voltage of the liquid crystal capacitor Clc, that is, a pixel voltage. The alignment directions of liquid crystal molecules depend on the level of the pixel voltage, which causes the polarization of light passing through the liquid crystal layer 3 to vary. The variation in polarization causes a variation in the transmittance of light by the polarizer mounted on the liquid crystal panel assembly 300.

[0037] These processes are repeatedly performed for every one horizontal period (which is referred to as “1H” and is equal to one period of the horizontal synchronization signal Hsync and the data enable signal DE). In this way, the gate-on voltage Von is sequentially applied to all the gate lines G_1 to G_n , and the data signals are supplied to all the pixels PX, thereby displaying one frame of images. When one frame has ended, the next frame starts. In this case, the state of the inversion signal RVS applied to the data driver 500 is controlled such that the polarity of the data signal applied to each pixel PX is opposite to the polarity of the data signal in the previous frame (“frame inversion”). The polarity of the data signal applied to one data line may be inverted in the same frame according to the characteristic of the inversion signal RVS (for example, row inversion and dot inversion), and the polarities of the data signals applied to a row of pixels may be different from each other (for example, column inversion and dot inversion).

[0038] Next, a liquid crystal panel assembly according to an exemplary embodiment of the present invention and a gate driver formed in the liquid crystal panel assembly will be described in detail with reference to FIGS. 4 to 9. FIG. 4 is a top plan view illustrating a liquid crystal panel assembly according to an exemplary embodiment of the present invention, FIG. 5 is a cross-sectional view of the liquid crystal panel assembly taken along the line V-V of FIG. 4, and FIG. 6 is a top plan view illustrating in detail an edge of the liquid crystal panel assembly shown in FIG. 4.

[0039] Referring to FIG. 4 to FIG. 6, a liquid crystal panel assembly according to an exemplary embodiment of the present invention includes a thin film transistor array panel 100, a common electrode panel 200 (refer to FIG. 1) a liquid crystal layer 3 (refer to FIG. 1) interposed between the two

display panels 100 and 200, and a sealant 310 for sealing the liquid crystal layer 3. The liquid crystal panel assembly 300 has a display area DA and a peripheral area PA disposed at one side of the display area DA. The data driver 500 connected to the data lines D_1 to D_m is mounted in the peripheral area PA of a substrate 110. For example, the gate lines G_1 to G_n , the data lines D_1 to D_m intersecting the gate lines G_1 to G_n , thin film transistors (not shown) connected to the gate lines G_1 to G_n and the data lines D_1 to D_m , and pixel electrodes 191 connected to the thin film transistors are formed in the display area DA of the substrate 110.

[0040] The gate drivers 400 are integrated at both sides of the display area DA. Each of the gate drivers 400 has a plurality of gate driving circuits 410. Each of the gate drivers 400 includes a first region 400a in which the gate driving circuits 410 are arranged in a line and second regions 400b that are not aligned with the first region 400a. The second regions 400b are arranged at the upper and lower sides of the first region 400a. In the second regions 400b, at least one of the gate driving circuits 410 is arranged closer to the display area DA than the gate driving circuits 410 of the first region 400a. It is preferable that a distance D between the uppermost gate driving circuit 410 of the second region 400b and the gate driving circuits 410 of the first region 400a be smaller than 300 μm (micrometers). A sealant 310 is formed in the periphery of the display area DA, and edge portions 311 of the sealant 310 are rounded or chamfered, in view of a subsequent process. The position of the second regions 400b of the gate driver 400 is substantially identical to that of the edge portions 311 of the sealant 310. Therefore, the gate driver 400 is covered with the sealant 310. In this way, it is possible to prevent the gate driver 400 from being exposed to the air, water and other material generated in a process etc and thereby corroded. Particularly, portions 410a of the gate driver 400 opposite to the display area DA, including the edge portions 311 of the sealant 310, are covered with the sealant 310. The common electrode panel 200 is bonded to the thin film transistor array panel 100 by the sealant 310. A light shielding layer 220 is formed on a substrate 210 of the common electrode panel 200, and the common electrode 270 is formed on the light shielding layer 220. Color filters (not shown) may be formed between the substrate 210 and the common electrode 270. Alternatively, the color filters may be formed on the thin film transistor array panel 100.

[0041] Next, a liquid crystal panel assembly according to another exemplary embodiment of the present invention will be described in detail with reference to FIGS. 7 and 8. FIG. 7 is a top plan view illustrating a liquid crystal panel assembly according to an exemplary embodiment of the present invention, and FIG. 8 is a top plan view illustrating in detail an edge portion of the liquid crystal panel assembly shown in FIG. 7. Since the structure shown in FIG. 7 is substantially similar to the cross-sectional structure shown in FIG. 5, components shown in FIG. 7 have the same reference numerals as those shown in FIG. 5.

[0042] Referring to FIGS. 7 and 8, a liquid crystal panel assembly according to an exemplary embodiment of the present invention includes a thin film transistor array panel 100, a common electrode panel 200, a liquid crystal layer 3 interposed between the two display panes 100 and 200, and a sealant 310 for sealing the liquid crystal layer 3. The liquid crystal panel assembly 300 includes a display area DA for displaying images and a peripheral area PA disposed at one

side of the display area DA. A data driver **500** connected to data lines D_1 to D_m is provided in the peripheral area PA of a substrate **110**. For example, gate lines G_1 to G_n , the data lines D_1 to D_m intersecting the gate lines G_1 to G_n , thin film transistors (not shown) connected to the gate lines G_1 to G_n and the data lines D_1 to D_m , and pixel electrodes **191** connected to the thin film transistors are formed in the display area DA of the substrate **110**.

[**0043**] Gate drivers **400L**, **400R**, and **400D** are formed in the peripheral areas PA as integrated circuits. Each of the gate drivers **400L**, **400R**, and **400D** includes a plurality of gate driving circuits **410** and **420**. More specifically, the first and second gate drivers **400L** and **400R** are formed in the peripheral areas PA disposed at both sides of the display area DA, and the third gate driver **400D** is formed in the peripheral area PA disposed at the lower side of the display area DA. The third gate driver **400D** may be formed in a portion of the peripheral area PA at the lower side of the display area DA. Signal lines for connecting the data driver **500** to the display area DA are formed in the peripheral area PA disposed at the upper side of the display area DA. The first and second gate drivers **400R** and **400L** are connected to the gate lines G_1 to G_n formed in the display area DA to substantially apply gate signals to the gate lines G_1 to G_n . The third gate driver **400D** is a dummy driver for compensating for the step difference between the display area DA and the peripheral areas PA having the first and second gate drivers **400R** and **400L** formed therein. Therefore, the third gate driver **400D** is not connected to the gate lines G_1 to G_n formed in the display area DA. The third gate driver **400D** is connected to the first gate driver **400L** and the second gate driver **400R** via wirings made of the same material as the gate lines or data lines. The signal lines for connecting the data lines D_1 to D_m to the data driver **500** are not formed in the peripheral area PA disposed at the upper side of the display area DA. Therefore, the compensation for the step difference is not needed in the upper peripheral area PA.

[**0044**] As shown in FIG. 7, the data driver **500** is provided in the peripheral area PA disposed at the upper side of the display area DA, and the third gate driver **400D** is provided in the peripheral area PA disposed at the lower side of the display area DA. However, the positional relationship between the data driver **500** and the third gate driver **400D** may be changed. Meanwhile, the first and second gate drivers **400L** and **400R** are connected to the third gate driver **400D**. The sealant **310** is formed in the periphery of the display area DA, and edge portions **311** of the sealant **310** are rounded or chamfered, in view of a subsequent process. The gate drivers **400** are not formed at the edge portions **311** of the sealant **310**. That is, the first and second gate drivers **400L** and **400R** are formed along portions **312** of the sealant **310** parallel to straight portions of the display area DA, and the gate drivers **400** are not provided in the edge portions **311** that are bent from the portions **312** of the sealant **310** parallel to the straight portions of the display area DA. Therefore, the gate drivers **400** are completely covered with the sealant **310**. In this way, it is possible to prevent the gate drivers **400** from being exposed to the outside and being corroded. The common electrode panel **200** is bonded to the thin film transistor array panel **100** by the sealant **310**. A light shielding layer **220** is formed on a substrate **210** of the common electrode panel **200**, and a common electrode **270** is formed on the light shielding layer **220**. Color filters (not shown) may be formed between the substrate **210** and the

common electrode **270**. Alternatively, the color filters may be formed on the thin film transistor array panel **100**.

[**0045**] Next, a gate driver **400** of a liquid crystal panel assembly according to an exemplary embodiment of the present invention will be described in detail with reference to FIGS. 9 and 10. FIG. 9 is a block diagram illustrating a gate driver according to an exemplary embodiment of the present invention, and FIG. 10 is a circuit diagram illustrating a j-th stage of a shift register for a gate driver according to an exemplary embodiment of the present invention. Referring to FIGS. 9 and 10, first and second scanning start signals LSTV and RSTV, and first to fourth clock signals LCLK1, RCLK1, LCLK2, and RCLK2 are input to shift registers **400L** and **400R**, serving as the gate drivers **400**, respectively. Each of the shift registers **400L** and **400R** includes a plurality of stages ST1 to STj+3 connected to the gate lines. The plurality of stages ST1 to STj+3 are connected to one another in a cascade manner, and are supplied with the first and second scanning start signals LSTV and RSTV and the first to fourth clock signals LCLK1, RCLK1, LCLK2, and RCLK2.

[**0046**] The first scanning start signal LSTV input to the left shift register **400L** and the second scanning start signal RSTV input to the right shift register **400R** are signals having one frame period in which a pulse having a width of 1H is included in one frame. In each of the shift registers **400L** and **400R**, different clock signals LCLK1, RCLK1, LCLK2, and RCLK2 are input to two adjacent stages. For example, the first clock signal LCLK1 is input to the first stage of the left shift register **400L**, and the third clock signal LCLK2 is input to the second stage thereof. The second clock signal RCLK1 is input to the first stage of the right shift register **400R**, and the fourth clock signal RCLK2 is input to the second stage thereof. When each of the clock signals LCLK1, RCLK1, LCLK2, and RCLK2 is at a high level, it may be the gate-on voltage Von for driving the switching element Q of the pixel. Conversely, when the clock signals are at low levels, they may be gate-off voltages Voff.

[**0047**] Each of the stages has a set terminal S, a gate voltage terminal GV, a pair of clock terminals CK1 and CK2, a reset terminal R, a frame reset terminal FR, a gate output terminal OUT1, and a carry output terminal OUT2. For example, a carry output Cout(j-2) of a previous stage ST(j-2) is input to the set terminal S of a j-th stage STj, and a gate output Gout(j+2) of the next stage ST(j+2) is input to the reset terminal R of the j-th stage STj. In addition, the clock signals LCLK1 and LCLK2 are input to the clock terminals CK1 and CK2 of the j-th stage STj, respectively, and the gate-off voltage Voff is input to the gate voltage terminal GV thereof. The gate output terminal OUT1 outputs a gate output Gout(j), and the carry output terminal OUT2 outputs a carry output Cout(j). However, instead of the previous carry out, the scanning start signals LSTV and RSTV are input to the first stages of the shift registers **400L** and **400R**, respectively. In addition, when the clock signal LCLK1 is input to the clock terminal CK1 of the j-th stage STj and the clock signal LCLK2 is input to the clock terminal CK2 thereof, the clock signal LCLK2 is input to the clock terminals CK1 of the (j-2)-th and (j+2)-th stages ST(j-2) and ST(j+2) adjacent to the j-th stage STj, and the clock signal LCLK1 is input to the clock terminals CK2 thereof.

[0048] Referring to FIG. 10, each stage, for example, the j -th stage, of the gate driver 400 according to an exemplary embodiment of the present invention includes an input section 420, a pull-up driver 430, a pull-down driver 440, and an output section 450. These components each include at least one NMOS transistor T1 to T14, and the pull-up driver 430 and the output section 450 further include capacitors C1 to C3. However, PMOS transistors may be used instead of the NMOS transistors. The capacitors C1 to C3 may be substantially parasitic capacitances between a gate and a drain/source formed in the manufacturing process. The input section 420 includes three transistors T11, T10, and T5 connected in series between the set terminal S and the gate voltage terminal GV. The gate of each of the transistors T11 and T5 is connected to the clock terminal CK2, and the gate of the transistor T10 is connected to the clock terminal CK1. A connection point between the transistor T11 and the transistor T10 is connected to a connection point J1, and a connection point between the transistor T10 and the transistor T5 is connected to a connection point J2.

[0049] The pull-up driver 430 includes the transistor T4 connected between the set terminal S and the connection point J1, the transistor T12 connected between the clock terminal CK1 and a connection point J3, and the transistor T7 connected between the clock terminal CK1 and a connection point J4. The gate and the drain of the transistor T4 are connected to the set terminal S, and the source thereof is connected to the connection point J1. The gate and the drain of the transistor T12 are connected to the clock terminal CK1, and the source thereof is connected to the connection point J3. The gate of the transistor T7 is connected to the connection point J3 and is also connected to the clock terminal CK1 through the capacitor C1. In addition, the drain of the transistor T7 is connected to the clock terminal CK1, and the source thereof is connected to the connection point J4. A capacitor C2 is connected between the connection points J3 and J4.

[0050] The pull-down driver 440 includes a plurality of transistors T6, T9, T13, T8, T3, and T2 that receive the gate-off voltage Voff and output it to the connection points J1, J2, J3, and J4 through their drains. The gate of the transistor T6 is connected to the frame reset terminal FR, and the drain thereof is connected to the connection point J1. The gate of the transistor T9 is connected to the reset terminal R, and the drain thereof is connected to the connection point J1. The gates of the transistors T13 and T8 are connected to the connection point J2, and the drains thereof are connected to the connection points J3 and J4, respectively. The gate of the transistor T3 is connected to the connection point J4, and the gate of the transistor T2 is connected to the reset terminal R. The drains of the two transistors T3 and T2 are connected to the connection point J2.

[0051] The output section 450 includes a pair of transistors T1 and T14 each having a drain and a source respectively connected between the clock terminal CK1 and the output terminals OUT1 and OUT2 and a gate connected to the connection point J1, and the capacitor C3 connected between the gate and the drain of the transistor T1, that is, between the connection points J1 and J2. The source of the transistor T1 is connected to the connection point J2. Next, the operation of this stage will be described as follows. For better comprehension and ease of description, a voltage corresponding to the high level of the clock signal LCLK1, LCLK2, RCLK1, or RCLK2 is referred to as a high voltage,

and a voltage corresponding to the low level of the clock signal LCLK1, LCLK2, RCLK1, or RCLK2 is referred to as a low voltage. The level of the low voltage is equal to that of the gate-off voltage Voff.

[0052] First, when the clock signal LCLK2 and the previous carry output Cout(j-2) change to high levels, or go high, the transistors T11, T5, and T4 are turned on. Then, the two transistors T11 and T4 transmit the high voltage to the connection point J1, and the transistor T5 transmits the low voltage to the connection point J2. The transistors T1 and T14 are turned on to cause the clock signal CLK1 to be output from the output terminals OUT1 and OUT2. At that time, since the voltage levels of the connection point J2 and the clock signal LCLK1 are low, the output voltages Gout(j) and Cout(j) become low. Simultaneously, the capacitor C3 is charged with a voltage corresponding to the difference between the high voltage and the low voltage. In this case, since the clock signal LCLK1 and the next gate output Gout(j+2) are at low levels and the connection point J2 is at a low level, the transistors T10, T9, T12, T13, T8, and T2 having gates connected to one another are in an off state.

[0053] When the clock signal LCLK2 changes to a low level, or goes low, the transistors T11 and T5 are turned off. At that time, when the clock signal LCLK1 changes to a high level, the output voltage of the transistor T1 and the voltage of the connection point J2 change to high levels. At this time, a high voltage is applied to the gate of the transistor T10, and the potential of the source connected to the connection point J2 is at a high level. Therefore, the potential difference between the gate and the source is zero, and thus the transistor T10 is kept in an off state. Therefore, the connection point J1 is in a floating state, and thus the potential increases by the high voltage by means of the capacitor C3.

[0054] Meanwhile, since the potentials of the clock signal LCLK1 and the connection point J2 are at high levels, the transistors T12, T13, and T8 are turned on. In this state, the transistor T12 and the transistor T13 are connected in series to each other between the high voltage and the low voltage, and thus the connection point J3 has a voltage value divided by resistance values when the transistors T12 and T13 are turned on. However, if the resistance value when the transistor T13 is turned on is significantly higher than that when the transistor T12 is turned on, for example, if the resistance value when the transistor T13 is turned on is ten thousand times higher than that when the transistor T12 is turned on, the voltage of the connection point J3 is substantially equal to the high voltage. Therefore, the transistor T7 is turned on and then connected in series to the transistor T8, which causes the connection point J4 to have a voltage value divided by resistance values when the two transistors T7 and T8 are turned on. At this time, when the resistance values when the transistors T7 and T8 are turned on are set to be substantially equal to each other, the connection point J4 has an intermediate voltage value between the high voltage and the low voltage, which causes the transistor T3 to be kept in an off state. At that time, since the next gate output Gout(j+2) is at a low level, the transistors T9 and T2 are also kept in an off state. Therefore, the output terminals OUT1 and OUT2 are connected to only the clock terminal CK1 and are disconnected from the low voltage terminal, so that a high voltage is output from the output terminals OUT1 and OUT2. Meanwhile, the capacitor C1 and the capacitor C2 are charged with a voltage corresponding to the potential

difference therebetween, and the voltage of the connection point J3 is lower than that of the connection point J5.

[0055] Subsequently, when the next gate output Gout(j+1) and the clock signal CLK2 turn to high levels and the clock signal CLK1 changes to a low level, the transistors T9 and T2 are turned on to apply a low voltage to the connection points J1 and J2. At that time, the voltage of the connection point J1 drops to a low level due to the discharge of the capacitor C3, and the discharge of the capacitor C3 causes a predetermined amount of time to be required, or introduces a delay, for the voltage to drop to the low level. Therefore, after the next gate output Gout(j+1) changes to a high level, the two transistors T1 and T14 are kept on for a period of time, so that the output terminals OUT1 and OUT2 are connected to the clock terminal CK1, and the low voltage is output from the output terminals OUT1 and OUT2. When the capacitor C3 is completely discharged and the potential of the connection point J1 reaches a low level, the transistor T14 is turned off causing the output terminal OUT2 to be effectively disconnected from the clock terminal CK1. Therefore, the carry output Cout(j) becomes a floating state, and thus the low voltage is kept. At the same time, the output terminal OUT1 is connected to the low voltage terminal through the transistor T2 even when the transistor T1 is turned off. Therefore, the low voltage is continuously output from the output terminal OUT1.

[0056] Meanwhile, when the transistors T12 and T13 are turned off, the connection point J3 becomes a floating state. In addition, the voltage of the connection point J5 is lower than the voltage of the connection point J4, and the voltage of the connection point J3 is kept lower than the voltage of the connection point J5 by the capacitor C1, which causes the transistor T7 to be turned off. At the same time, the transistor T8 is turned off, and the voltage of the connection point J4 is lowered, or brought low, which causes the transistor T3 to be kept in an off state. Further, since the low level clock signal CLK1 is input to the gate of the transistor T10 and the voltage of the connection point J2 is low, the transistor T10 is kept in an off state. Then, when the clock signal CLK1 changes to a high level, the transistors T12 and T7 are turned on, and the voltage of the connection point J4 increases, which causes the transistor T3 to be turned on. Then, the low voltage is transmitted to the connection point J2, and thus the low voltage is continuously output from the output terminal OUT1. That is, even when the next gate output Gout(j+1) is at a low level, the voltage of the connection point J2 can be at a low level.

[0057] Meanwhile, since the high level clock signal CLK1 is input to the gate of the transistor T10 and the voltage of the connection point J2 is low, the transistor T10 is turned on, and thus the low voltage of the connection point J2 is applied to the connection point J1. Meanwhile, since the drains of the two transistors T1 and T14 are connected to the clock terminal CK1, the clock signal CLK1 is continuously supplied to the drains. Particularly, the size of the transistor T1 is larger than those of the other transistors, which introduces a parasitic capacitance between the gate and the drain of the transistor T1. As a result, a variation in the voltage of the drain may affect the gate voltage. Therefore, when the clock signal CLK1 changes to a high level, the gate voltage increases due to the parasitic capacitance between the gate and the drain, which may cause the transistor T1 to be turned on. Thus, the gate voltage of the transistor T1 is kept at a low level by applying the low voltage of the

connection point J2 to the connection point J1, which prevents the transistor T1 from being turned on. Thereafter, the voltage of the connection point J1 is kept at a low level until the next carry output Cout(j-2) changes to a high level. The voltage of the connection point J2 becomes low through the transistor T3 when the clock signal CLK1 is at a high level and the clock signal CLK2 is at a low level. The voltage of the connection point J2 is kept at a low level through the transistor T5 when the clock signal CLK1 is at a low level and the clock signal CLK2 is at a high level. Meanwhile, the transistor T6 receives an initializing signal INT generated in the last dummy stage (not shown) and transmits the gate-off voltage Voff to the connection point J1, thereby setting the voltage of the connection point J1 to a low voltage again. In this way, the stage 410 generates the carry signal Cout(j) and the gate signal Gout(j), on the basis of the previous carry signal Cout(j-2) and the next gate signal Gout(j+2), in synchronization with the clock signals LCLK1 and LCLK2.

[0058] Next, the arrangement of the gate driver 400 on the thin film transistor array panel 100 shown in FIGS. 4 and 7 will be described in detail with reference to FIGS. 11 and 12, respectively. FIG. 11 is a layout view schematically illustrating the gate driver 400 shown in FIG. 4, and FIG. 12 is a layout view schematically illustrating the gate driver 400 shown in FIG. 7. Referring to FIG. 11, the gate driver 400 according to an exemplary embodiment of the invention includes circuit portions CS composed of the stages ST1 to STj+3 and wiring portions LS for transmitting various signals Voff, LCKV1, RCKV1, LCKV2, RCKV2, and INT input to the stages ST1 to STj+3. However, only the gate driver 400 formed on the left of the display area DA is shown in FIG. 11.

[0059] Each of the wiring portions LS includes a gate-off voltage line SL1 for transmitting the gate-off voltage Voff, first and second clock signal lines SL2 and SL3 for transmitting the first and second clock signals LCKV1, RCKV1, LCKV2, and RCKV2, respectively, and an initializing signal line SL4 for transmitting the initializing signal INT. The signal lines SL1 to SL4 extend substantially in the vertical direction. The gate-off voltage line SL1, the clock signal lines SL2 and SL3, and the initializing signal line SL4 are arranged in this order from the left, so that the initializing signal line SL4 is closest to the shift register 400, followed by the clock signal lines SL3 and SL2 and the gate-off voltage line SL1. The positional relationship between the gate-off voltage line SL1 and the initializing signal line SL4 may be changed. In addition, the signal lines SL1 to SL4 have extension lines extending toward the stages ST1, ST3, ST5, and ST7 in the horizontal direction. The extension lines of the gate-off voltage line SL1 and the initializing signal line SL4 extend toward each of the stages ST1, ST3, ST5, and ST7. The extension lines of the first and second clock signal lines SL2 and SL3 alternately extend toward the stages ST1, ST3, ST5, and ST7 at boundaries among the stages ST1, ST3, ST5, and ST7.

[0060] In the arrangement of the transistors T1 to T13 and T15 in the first stage ST1 among the stages ST1, ST3, ST5, and ST7 in the circuit portions CS, the transistor T4 to which the previous carry signal Cout(j-1) is input is disposed at the upper left side of the first stage ST, which is closest to the previous stage, and the transistors T1 and T15 to which the first clock signal LCKV1 is input are arranged along the extension line of the first clock signal line SL2 which

extends in the horizontal direction above the transistors T1 and T15. In addition, the transistors T7, T10, and T12 to which the first clock signal LCKV1 is input are disposed below the transistor T15. The transistors T11 and T5 are disposed at a lower left side of the first stage ST1 and are connected to the extension line of the second clock signal line SL3 in the next stage so as to receive the second clock signal LCKV2. The transistor T6 that is connected to the initializing signal line SL4 extending from the left and receives the initializing signal INT is arranged at the leftmost side. The transistors T2, T3, T8, T9, and T13 to which the gate-off voltage Voff is input are disposed at the lower side of the first stage ST1 along the extension line of the gate-off voltage line SL1 extending in the horizontal direction.

[0061] In the third stage ST3 adjacent to the first stage ST1, the arrangement of the transistors is similar to the arrangement of the transistors in the first stage ST1 except that the first clock signal line SL2 and the first clock signal LCKV1 are replaced with the second clock signal line SL3 and the second clock signal LCKV2, respectively, and the second clock signal line SL3 and the second clock signal LCKV2 are replaced with the first clock signal line SL2 and the first clock signal LCKV1, respectively. Some of the circuit portions CS and the wiring portions LS are arranged in a line, and the other circuit portions CS and wiring portions LS are not aligned with the circuit portions CS and the wiring portions LS arranged in a line in the vertical direction. That is, the first stage ST1 is closest to the display area DA, followed by the third stage ST3 and the fifth stage ST5. The distance between the fifth stage ST5 and the display area DA is the largest. The following stages from the seventh stage ST7 on are aligned with the fifth stage ST5. Therefore, the wiring portions LS in adjacent stages from the fifth stage ST5 on are arranged in a line. However, the wiring portion LS adjacent to the third stage ST3 is bent toward the display area DA and is not aligned with the wiring portion LS adjacent to the fifth stage ST5, and the wiring portion LS adjacent to the first stage ST1 is bent toward the display area DA and is not aligned with the wiring portion LS adjacent to the third stage ST3. Thus, the gate driver 400 has the first region 400a in which the wiring portions LS are arranged in a line and the second region 400b not aligned with the first region 400a. The first and third stages ST1 and ST3 and the wiring portions LS adjacent thereto form the second region 400b, and the fifth and seventh stages ST5 and ST7 and the wiring portions LS adjacent thereto form the first region 400a. Although not shown in detail in FIG. 11, as shown in FIG. 4, the lower part of the gate driver 400 has the same structure as that shown in FIG. 11.

[0062] According to one or more embodiments of the present invention, the gate driver integrated into the display panel can be covered with the sealant at the edge portions of the sealant. Therefore, it is possible to effectively protect the gate driver from external environments. Referring to FIG. 12, the gate driver 400 according to the exemplary embodiment of the present invention includes the circuit portions CS composed of the stages ST1 to STj+3 and the wiring portions LS for transmitting various signals Voff, LCKV1, RCKV1, LCKV2, RCKV2, and INT input to the stages ST1 to STj+3. However, only the gate driver 400 formed at the left side of the display area DA is shown in FIG. 12.

[0063] Each of the wiring portions LS includes a gate-off voltage line SL1 for transmitting the gate-off voltage Voff,

first and second clock signal lines SL2 and SL3 for transmitting the first and second clock signals LCKV1, RCKV1, LCKV2, and RCKV2, respectively, and an initializing signal line SL4 for transmitting the initializing signal INT. The signal lines SL1 to SL4 extend substantially in the vertical direction. The gate-off voltage line SL1, the clock signal lines SL2 and SL3, and the initializing signal line SL4 are arranged in this order from the left, so that the initializing signal line SL4 is closest to the shift register 400, followed by the clock signal lines SL3 and SL2 and the gate-off voltage line SL1. The positional relationship between the gate-off voltage line SL1 and the initializing signal line SL4 may be changed. In addition, the signal lines SL1 to SL4 have extension lines extending toward the stages ST1, ST3, ST5, and ST7 in the horizontal direction. The extension lines of the gate-off voltage line SL1 and the initializing signal line SL4 extend toward each of the stages ST1, ST3, ST5, and ST7. The extension lines of the first and second clock signal lines SL2 and SL3 alternately extend toward the stages ST1, ST3, ST5, and ST7 at boundaries among the stages ST1, ST3, ST5, and ST7.

[0064] In the arrangement of transistors T1 to T13 and T15 in the first stage ST1 among the stages ST1, ST3, ST5, and ST7 in the circuit portions CS, the transistor T4 to which the previous carry signal Cout(j-1) is input is disposed at the upper left side of the first stage ST1, which is closest to the previous stage, and the transistors T1 and T15 to which the first clock signal LCKV1 is input are arranged along the extension line of the first clock signal line SL2 that extends in the horizontal direction above the transistors T1 and T15. In addition, the transistors T7, T10, and T12 to which the first clock signal LCKV1 is input are disposed below the transistor T15. The transistors T11 and T5 are disposed at a lower left side of the first stage ST1 and are connected to the extension line of the second clock signal line SL3 in the next stage so as to receive the second clock signal LCKV2. The transistor T6 that is connected to the initializing signal line SL4 extending from the left and receives the initializing signal INT is arranged at the leftmost side. The transistors T2, T3, T8, T9, and T13 to which the gate-off voltage Voff is input are disposed at the lower side of the first stage ST1 along the extension line of the gate-off voltage line SL1 extending in the horizontal direction. In the third stage ST3 adjacent to the first stage ST1, the arrangement of the transistors is similar to the arrangement of the transistors in the first stage ST1 except that the first clock signal line SL2 and the first clock signal LCKV1 are replaced with the second clock signal line SL3 and the second clock signal LCKV2, respectively, and the second clock signal line SL3 and the second clock signal LCKV2 are replaced with the first clock signal line SL2 and the first clock signal LCKV1, respectively. A description of the fifth stage ST5 will be omitted.

[0065] The wiring portion LS of the first gate driver 400L connected to the display area DA is connected to the wiring portion LS of the third gate driver 400D not connected to the display area DA. The first gate driver 400L is driven by the above-mentioned driving method. For example, the gate driving circuit disposed at the lowermost side may be driven first. As described above, the stage generates a self-carry signal and a self-gate signal, on the basis of the previous carry signal and the next gate signal, in synchronization with the clock signal. At that time, the first stage ST1 receives the initializing signal, instead of the previous carry signal, and

the initializing signal may be supplied from the dummy stage. When the first stage ST1 is driven last, the self-carry signal may be transmitted to the next stage. In this way, it is possible to prevent an error in the gate signal output from the gate driver 400. However, in the liquid crystal display according to one or more embodiments of the present invention, the gate driving circuit is not provided at the edge of the sealant 310. Therefore, a gate driving circuit serving as the dummy stage is needed. When the wiring portion LS of the lowermost gate driving circuit, which is driven first, of the first gate driver 400L is connected to the wiring portion LS of a first stage STD1 of the third gate driver 400D, the circuit portion CS of the first gate driving circuit of the third gate driver 400D, that is, a stage STD1, can be used as the dummy stage. Stages adjacent to the first stage STD1 are denoted by characters STD2 and STD3. Therefore, the third gate driver 400D has a function of compensating for the step difference of the substrate 110 and also has a function of assisting the driving of the first and second gate drivers 400L and 400R. According to one or more embodiments of the present invention, the gate driver integrated into the display panel can be covered with the sealant at the edge of the sealant. Therefore, it is possible to effectively protect the gate driver from external environments.

[0066] While this invention has been described in connection with what is presently considered to be practical exemplary embodiments, it is to be understood that the invention is not limited to the disclosed embodiments, but, on the contrary, is intended to cover various modifications and equivalent arrangements included within the spirit and scope of the claims.

What is claimed is:

1. A display device, comprising:
 - a substrate including a display area and a peripheral area around the display area;
 - a plurality of gate lines, each of the plurality of gate lines extending in a first direction; and
 - a first gate driver including a plurality of stages connected to the plurality of gate lines, each of the plurality of stages comprising transistors integrated on the peripheral area of the substrate,
 wherein
 - the first gate driver includes a first region including first stages of the plurality of stages, and a second region including second stages of the plurality of stages,
 - the first stages are aligned in a line in a second direction crossing the first direction,
 - the second stages are not aligned with the first stages in the second direction,
 - at least two of the second stages of the second region are not aligned with each other in the second direction, and
 - a first virtual straight line overlapping a first stage of the first stages and extending in the first direction passes the display area, and a second virtual straight line overlapping a second stage of the second stages and extending in the first direction passes the display area.
2. The display device of claim 1, wherein the first region and the second region are adjacent to each other in the second direction, and
 - the second stages are shifted in the first direction with respect to the first stage.

3. The display device of claim 1, wherein
 - a center position of the first stage is not aligned with a center position of the second stage in the second direction.
4. The display device of claim 1, wherein
 - the second stage includes a portion which does not overlap the first stage in the second direction and another portion which overlaps the first stages in the second direction.
5. The display device of claim 1, wherein
 - an output terminal of the second stage is not aligned with an output terminal of the first stage in the second direction.
6. The display device of claim 1, wherein
 - a gate line to which the first stage is connected and a gate line to which the second stage is connected to are adjacent to each other in the second direction.
7. The display device of claim 1, further comprising:
 - a second gate driver opposing the first gate driver with respect to the display area,
 - wherein the second gate driver includes a plurality of stages sequentially arranged.
8. The display device of claim 7, wherein
 - the first gate driver is connected even-numbered gate lines of the plurality of gate lines, and
 - the second gate driver is connected to even-numbered gate lines of the plurality of gate lines.
9. The display device of claim 1, further comprising:
 - a second gate driver opposing the first gate driver with respect to the display area,
 - wherein the second gate driver includes a plurality of stages sequentially arranged,
 - the first gate driver and the second gate driver are connected to the plurality of gate lines, and
 - a stage of the first gate driver and a stage of the second gate driver are connected to a same gate line of the plurality of gate lines.
10. The display device of claim 1, further comprising:
 - a plurality of transistors disposed in the display area and connected to the plurality of gate lines,
 - wherein the first stage and the second stage each include a same layer as a layer of the transistor in the display area.
11. The display device of claim 1, wherein
 - the plurality of stages of the first gate driver are sequentially arranged along an edge of the display area.
12. The display device of claim 1, wherein
 - the first gate driver further comprises a wiring portion connected to the first stages and the second stages, and
 - the wiring portion includes at least one bent portion adjacent to the first gate driver in the first direction.
13. The display device of claim 12, wherein
 - the wiring portion overlaps the display area in the first direction.
14. The display device of claim 12, wherein
 - the at least one bent portion includes a bent portion that is aligned with a boundary between the first stage and the second stage.
15. The display device of claim 14, wherein
 - the wiring portion includes a first portion extending substantially in the second direction and a second portion extending substantially in the first direction and connected to the first portion at the bent portion.

16. The display device of claim 14, wherein the at least one bent portion of the wiring portion is provided in plural.
17. The display device of claim 1, wherein the display device is a liquid crystal display.
18. A display device, comprising:
a substrate including a display area;
a plurality of gate lines extending substantially in a first direction and disposed in the display area; and
a first gate driver including a plurality of stages that are sequentially arranged and connected to at least a portion of the plurality of gate lines and a wiring portion connected to the plurality of stages,
wherein the wiring portion includes at least one bent portion adjacent to the plurality of stages in the first direction.
19. The display device of claim 18, wherein the first gate driver includes a first stage and a second stage that are adjacent to each other in a second direction different from the first direction, and a gate line to which the first stage is connected and a gate line to which the second stage is connected to are adjacent to each other in the second direction.
20. The display device of claim 18, further comprising:
a second gate driver opposing the first gate driver with the display area interposed between the first gate driver and the second driver,
wherein the second gate driver includes a plurality of stages sequentially arranged, and
the first gate driver and the second gate driver are connected to the plurality of gate lines alternately.
21. The display device of claim 20, wherein the first gate driver is connected even-numbered gate lines of the plurality of gate lines, and the second gate driver is connected to even-numbered gate lines of the plurality of gate lines.
22. The display device of claim 18, further comprising:
a second gate driver opposing the first gate driver with the display area interposed between the first gate driver and the second driver,
wherein the second gate driver includes a plurality of stages sequentially arranged, and
the first gate driver and the second gate driver are connected to the plurality of gate lines, and
a stage of the first gate driver and a stage are connected to a same gate line of the plurality of gate lines).
23. The display device of claim 18, wherein the wiring portion overlaps the display area in the first direction.
24. The liquid crystal display of claim 18, wherein the first gate driver includes a first stage and a second stage that are adjacent to each other in a second direction different from the first direction, and the at least one bent portion includes a bent portion that is aligned with a boundary between the first stage and the second stage.
25. The liquid crystal display of claim 24, wherein the wiring portion includes a first portion extending substantially in the second direction and a second portion extending substantially in the first direction and connected to the first portion at the bent portion.
26. The display device of claim 24, wherein the second direction is substantially perpendicular to the first direction.
27. The display device of claim 18, further comprising:
a plurality of transistors disposed in the display area and connected to the plurality of gate lines,
wherein the plurality of stages include a same layer as a layer of the transistor in the display area.
28. The display device of claim 18, wherein the plurality of stages includes at least one NMOS transistor.
29. The display device of claim 18, wherein the plurality of stages includes at least one PMOS transistor.
30. The display device of claim 18, wherein the plurality of stages of the first gate driver are sequentially arranged along an edge of the display area, the edge of the display area being adjacent to the first gate driver.
31. The display device of claim 18, wherein the at least one bent portion of the wiring portion is provided in plural.
32. The display device of claim 18, wherein the display device is a liquid crystal display.
33. A display device, comprising:
a substrate including a display area;
a plurality of gate lines extending substantially in a first direction and disposed in the display area; and
a first gate driver including a plurality of stages sequentially arranged and a wiring portion connected to the plurality of stages, the plurality of stages including a first stage and a second stage each connected to a respective gate line of the plurality of gate lines,
wherein the first stage and the second stage are adjacent to the display area in the first direction, the first stage and the second stage are adjacent to each other in a second direction that is different from the first direction, and the second stage is shifted in the first direction with respect to the first stage, and
the wiring portion includes at least one bent portion adjacent to the plurality of stages in the first direction.

* * * * *

专利名称(译)	液晶显示器		
公开(公告)号	US20190243202A1	公开(公告)日	2019-08-08
申请号	US16/384482	申请日	2019-04-15
[标]申请(专利权)人(译)	三星显示有限公司		
申请(专利权)人(译)	三星DISPLAY CO., LTD.		
当前申请(专利权)人(译)	三星DISPLAY CO., LTD.		
[标]发明人	YANG YONG HO YOON JOO SUN JEONG KI HUN		
发明人	YANG, YONG-HO YOON, JOO-SUN JEONG, KI-HUN		
IPC分类号	G02F1/1362 G02F1/1368 G09G3/36 H01L33/52		
CPC分类号	G02F1/136286 G02F1/1368 G09G3/3677 H01L33/52 G09G2300/0809 G09G2310/0281 G09G2300/0408 G09G2300/0426		
优先权	1020060005260 2006-01-18 KR 1020060016105 2006-02-20 KR		
其他公开文献	US10690982		
外部链接	Espacenet USPTO		

摘要(译)

根据本发明示例性实施例的液晶显示器包括基板，在基板上以矩阵布置的多个像素，其中每个像素包括开关元件，多个栅极线连接到开关元件并延伸在行方向上，栅极驱动器连接到栅极线，并形成在基板上作为集成电路。在液晶显示器中，栅极驱动器包括第一区域和与第一区域对准的第二区域。

